

**PECL-TO-CML TRANSLATOR  
WITH OUTPUT ENABLE****SY100ELT982****FEATURES**

- Up to 1.25Gbps operation
- 25mA peak drive current
- Adjustable output current
- Separate output enable
- Differential inputs for data
- 75KΩ input pull-down resistor
- Single power supply
- Available in a tiny 10-pin MSOP

**DESCRIPTION**

The SY100ELT982 is a high speed PECL-to-CML translator. The output current is DC current controlled by  $I_{RSET}$ , current through the resistor  $R_{SET}$ . The output  $\overline{OUT}$  is LOW when output enable is HIGH.

The device incorporates complementary open collector outputs with a capability of driving peak current of 25mA.

The SY100ELT982 utilizes the high performance bipolar ASSET™ technology.

**APPLICATIONS**

- Telecommunications
- CML output oscillator
- GaAS interface

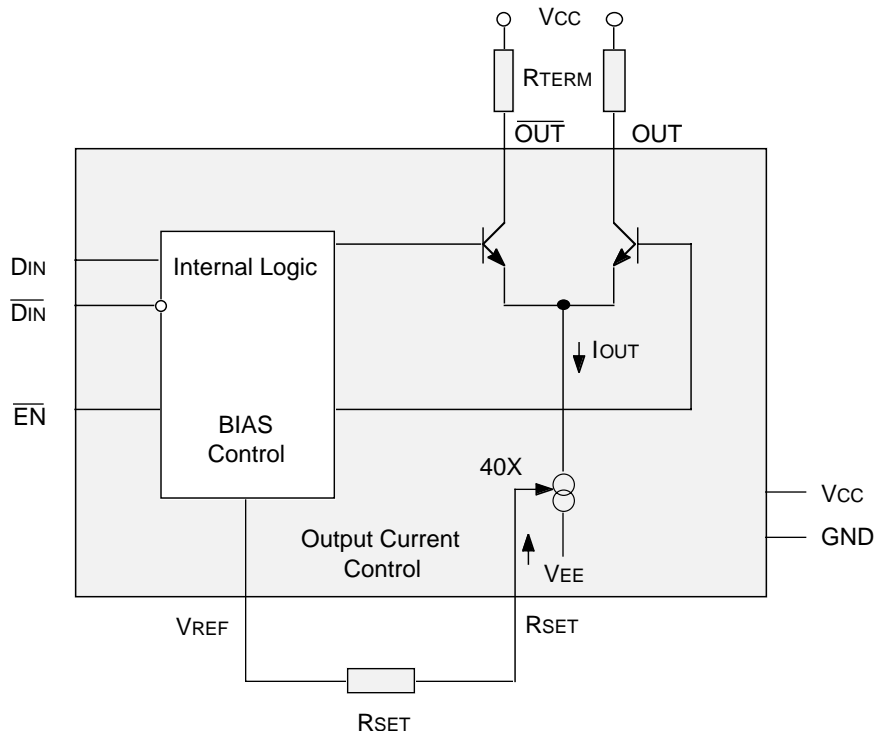
**BLOCK DIAGRAM**

**PACKAGE/ORDERING INFORMATION**

**Ordering Information<sup>(1)</sup>**

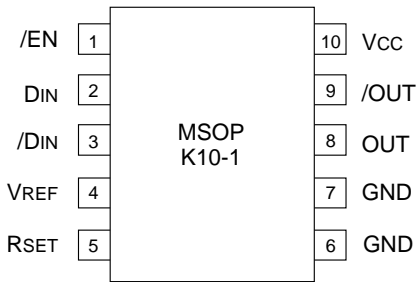

**10-Pin MSOP (K10-1)**

Part Number	Package Type	Operating Range	Package Marking	Lead Finish
SY100ELT982KC	K10-1	Commercial	XEL982	Sn-Pb
SY100ELT982KCTR <sup>(2)</sup>	K10-1	Commercial	XEL982	Sn-Pb
SY100ELT982KI	K10-1	Industrial	XEL982	Sn-Pb
SY100ELT982KITR <sup>(2)</sup>	K10-1	Industrial	XEL982	Sn-Pb
SY100ELT982KG <sup>(3)</sup>	K10-1	Industrial	XEL982 with Pb-Free bar-line indicator	Pb-Free NiPdAu
SY100ELT982KGTR <sup>(2, 3)</sup>	K10-1	Industrial	XEL982 with with Pb-Free bar-line indicator	Pb-Free NiPdAu

**Notes:**

1. Contact factory for die availability. Dice are guaranteed at  $T_A = 25^\circ\text{C}$ , DC Electricals only.
2. Tape and Reel.
3. Pb-Free package is recommended for new designs.

**PIN NAMES**

Pin	Function
VCC	Most positive power supply input, +5V for PECL operation.
GND	Ground
DIN, /DIN	Differential PECL 100K compatible inputs.
/EN	This PECL 100K compatible input enables data translation. When Enable asserted HIGH, OUT = IOUT, /OUT = 0mA.
OUT, /OUT	Open collector outputs from the output buffer drive these differential current outputs.
VREF	Voltage reference for use with RSET.
RSET	External resistor to adjust output current.

**TRUTH TABLE<sup>(1)</sup>**

D	/D	/EN	OUT <sup>(2)</sup>	/OUT <sup>(3)</sup>
L	H	L	L	H
H	L	L	H	L
X	X	H	L	H

**NOTE:**

1. L = LOW, H = HIGH, X = don't care
2. H = IOUT = 0mA
3. H = /IOUT = 0mA

**ABSOLUTE MAXIMUM RATINGS<sup>(1)</sup>**

Symbol	Rating	Value	Unit
VCC	Power Supply Voltage	0 to +7.0	V
VI	Input Voltage	0 to +6.0	V
IO	Output Current	25	mA
TLEAD	Lead Temperature (soldering, 20sec.)	+260	°C
TA	Operating Temperature Range	0°C to +85°C	°C
Tstore	Storage Temperature Range	-55°C to +125°C	°C
Ptot	Power Dissipation	250	mW

**Note:**

1. Permanent device damage may occur if absolute maximum ratings are exceeded. This is a stress rating only and functional operation is not implied at conditions other than those detailed in the operational sections of this data sheet. Exposure to absolute maximum rating conditions for extended periods may affect device reliability.

**OPERATING CONDITIONS<sup>(1)</sup>**

Symbol	Rating	Value	Unit
VCC	Power Supply Voltage	+4.5 to +5.5	V
RTERM	Resistor to Terminate Outputs	10 to 50	Ω
RSET	Resistor to Adjust Current	1500 to 50,000	Ω
θJA	Thermal Resistance of Package to Ambient <sup>(2)</sup>	206	°C/W
COU	Capacitance on OUT + /OUT	2.5 typical	pf

**Notes:**

1. The voltage drop across RTERM should not be greater than 2V.
2. Still air without heatsink.

**DC ELECTRICAL CHARACTERISTICS**

GND = 0V; VCC = +5.0V ±10%; TA = 0°C to + 85°C

Symbol	Parameter	TA = 0°C			TA = +25°C			TA = +85°C			Unit
		Min.	Typ.	Max.	Min.	Typ.	Max.	Min.	Typ.	Max.	
V <sub>IH</sub>	Input HIGH Voltage (Din, /Din, /EN)	V <sub>CC</sub> -1165	—	V <sub>CC</sub> -880	V <sub>CC</sub> -1165	—	V <sub>CC</sub> -880	V <sub>CC</sub> -1165	—	V <sub>CC</sub> -880	mV
V <sub>IL</sub>	Input LOW Voltage (Din, /Din, /EN)	V <sub>CC</sub> -1810	—	V <sub>CC</sub> -1475	V <sub>CC</sub> -1810	—	V <sub>CC</sub> -1475	V <sub>CC</sub> -1810	—	V <sub>CC</sub> -1475	mV
V <sub>REF</sub>	Reference Voltage	—	3.12	—	—	3.00	—	—	2.80	—	V
I <sub>IL</sub>	Input LOW Current <sup>(1)</sup> (Din, /Din, /EN)	0.5	—	—	0.5	—	—	0.5	—	—	µA
I <sub>IH</sub>	Input HIGH Current (Din, /Din, /EN)	—	—	100	—	—	100	—	—	100	µA
I <sub>CC</sub>	Supply Current <sup>(2)</sup>	—	16	25	—	16	25	—	16	25	mA
I <sub>OL</sub>	Output LOW Current (/EN = HIGH)	—	—	500	—	—	500	—	—	500	µA
I <sub>OR</sub>	Output Current Ringing <sup>(2)</sup>	—	—	10	—	—	10	—	—	10	%
I <sub>GAIN</sub>	I <sub>OUT</sub> /I <sub>RSET</sub>	30	38	44	30	38	44	30	38	44	—

**Notes:**

1. V<sub>I</sub> = V<sub>IL</sub>(Min.)
2. I<sub>OH</sub> = 25mA.

**AC ELECTRICAL CHARACTERISTICS<sup>(1)</sup>**I<sub>OH</sub> = 10mA; GND = 0V; VCC = +5V ±10%; TA = 0°C to + 85°C

Symbol	Parameter	TA = 0°C			TA = +25°C			TA = +85°C			Unit	Conditions
		Min.	Typ.	Max.	Min.	Typ.	Max.	Min.	Typ.	Max.		
t <sub>pd D</sub>	Propagation Delay Din - OUT	—	480	1000	—	480	1000	—	480	1000	ps	
t <sub>pd EN</sub>	Propagation Delay /EN - OUT	—	450	1000	—	450	1000	—	450	1000	ps	
t <sub>r</sub> t <sub>f</sub>	Rise/Fall Time (20% to 80%)	—	200	—	—	200	—	—	200	—	ps	
I <sub>OUT</sub>	Output Current	5	15	25	5	15	25	5	15	25	mA	
I <sub>RSET</sub>	Output Current Control	0.125	—	0.625	0.125	—	0.625	0.125	—	0.625	mA	
I <sub>OR</sub>	Output Current Ringing <sup>(2)</sup>	—	—	10	—	—	10	—	—	10	%	

**Notes:**

1. R<sub>TERM</sub> = 50Ω ±1%
2. I<sub>OH</sub> = 5 to 25mA

**APPLICATION EXAMPLE**

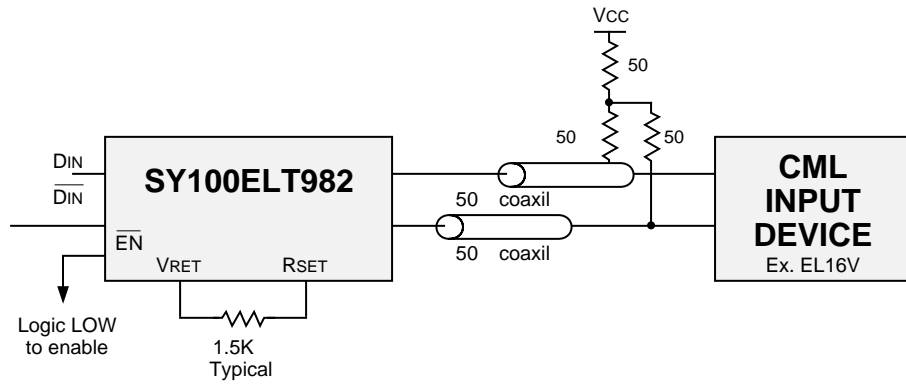

**PERFORMANCE CURVES**

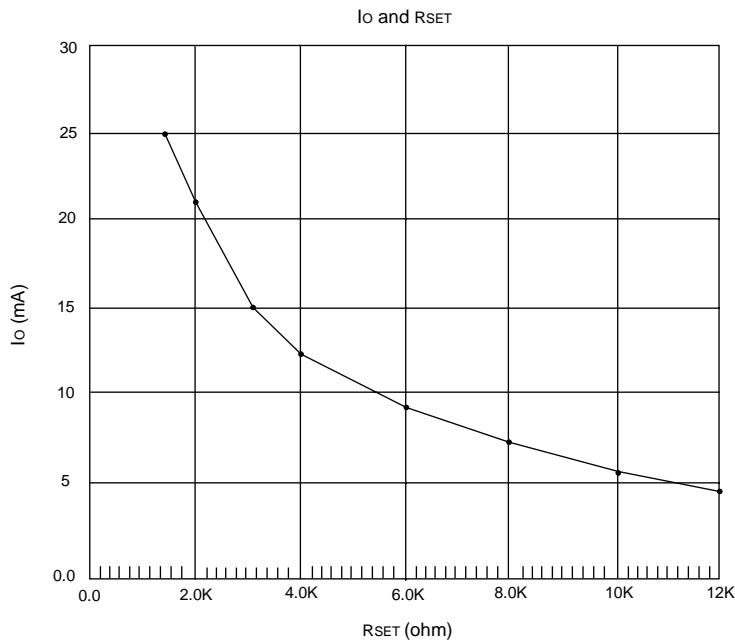

**10-PIN MSOP (K10-1)**

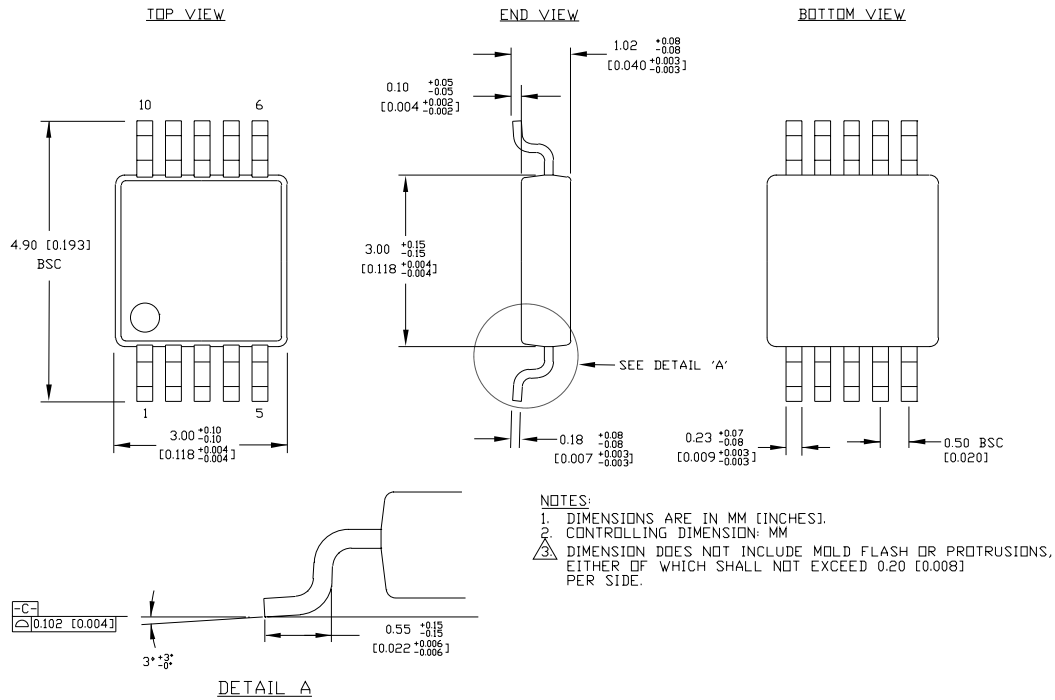

Rev. 00

**MICREL, INC. 2180 FORTUNE DRIVE SAN JOSE, CA 95131 USA**

TEL + 1 (408) 944-0800 FAX + 1 (408) 474-1000 WEB <http://www.micrel.com>

The information furnished by Micrel in this datasheet is believed to be accurate and reliable. However, no responsibility is assumed by Micrel for its use. Micrel reserves the right to change circuitry and specifications at any time without notification to the customer.

Micrel Products are not designed or authorized for use as components in life support appliances, devices or systems where malfunction of a product can reasonably be expected to result in personal injury. Life support devices or systems are devices or systems that (a) are intended for surgical implant into the body or (b) support or sustain life, and whose failure to perform can be reasonably expected to result in a significant injury to the user. A Purchaser's use or sale of Micrel Products for use in life support appliances, devices or systems is at Purchaser's own risk and Purchaser agrees to fully indemnify Micrel for any damages resulting from such use or sale.

© 2006 Micrel, Incorporated.

## X-ON Electronics

Largest Supplier of Electrical and Electronic Components

*Click to view similar products for [Translation - Voltage Levels](#) category:*

*Click to view products by [Micrel](#) manufacturer:*

Other Similar products are found below :

[NLSX4373DMR2G](#) [NLSX5012MUTAG](#) [NLSX0102FCT2G](#) [NLSX4302EBMUTCG](#) [PCA9306FMUTAG](#) [MC100EPT622MNG](#)  
[NLSX5011MUTCG](#) [NLV9306USG](#) [NLVSX4014MUTAG](#) [NLSV4T3144MUTAG](#) [NLVSX4373MUTAG](#) [MAX3371ELT+T](#)  
[NLSX3013BFCT1G](#) [NLV7WBD3125USG](#) [NLSX3012DMR2G](#) [74AVCH1T45FZ4-7](#) [NLVSV1T244MUTBG](#) [74AVC1T45GS-Q100H](#)  
[CLVC16T245MDGGREP](#) [MC10H124FNG](#) [CAVCB164245MDGGREP](#) [CD40109BPWR](#) [MC10H350FNG](#) [MC10H125FNG](#)  
[MC100EPT21MNR4G](#) [MC100EP91DWG](#) [NLSV2T244MUTAG](#) [NLSX3013FCT1G](#) [NLSX5011AMX1TCG](#) [PCA9306USG](#)  
[SN74GTL1655DGGR](#) [SN74AVCA406LZQSR](#) [NLSX4014DTR2G](#) [NLSX3018DTR2G](#) [LTC1045CN#PBF](#) [SY100EL92ZG](#)  
[74AXP1T34GMH](#) [74AXP1T34GNH](#) [LSF0204DPWR](#) [PI4ULS3V204LE](#) [ADG3245BRUZ-REEL7](#) [ADG3123BRUZ](#) [ADG3245BRUZ](#)  
[ADG3246BCPZ](#) [ADG3308BCPZ-REEL](#) [ADG3233BRJZ-REEL7](#) [ADG3233BRMZ](#) [ADG3241BKSZ-500RL7](#) [ADG3242BRJZ-REEL7](#)  
[ADG3243BRJZ-REEL7](#)