

FEATURES

- Input frequencies up to 135MHz
- PECL-to-TTL version of popular ECLinPS E111
- Guaranteed low skew specification
- Latched input
- Differential internal design
- VBB output VECL for single-ended operation
- Single +5V supply
- Reset/enable
- Extra TTL and ECL power/ground pins
- Choice of ECL compatibility: MECL 10KH (10Hxxx) or 100K (100Hxxx)
- Available in 28-pin PLCC package



Precision Edge®

DESCRIPTION

The SY10/100H641 are single supply, low skew translating 1:9 clock drivers. Devices in the Micrel H600 translator series utilize the 28-lead PLCC for optimal power pinning, signal flow-through and electrical performance.

The devices feature a 24mA TTL output stage with AC performance specified into a 50pF load capacitance. A latch is provided on-chip. When LEN is LOW (or left open, in which case it is pulled LOW by the internal pull-downs), the latch is transparent. A HIGH on the enable pin (\overline{EN}) forces all outputs LOW.

The 10H version is compatible with MECL 10KH ECL logic levels. The 100H version is compatible with 100K levels.

BLOCK DIAGRAM

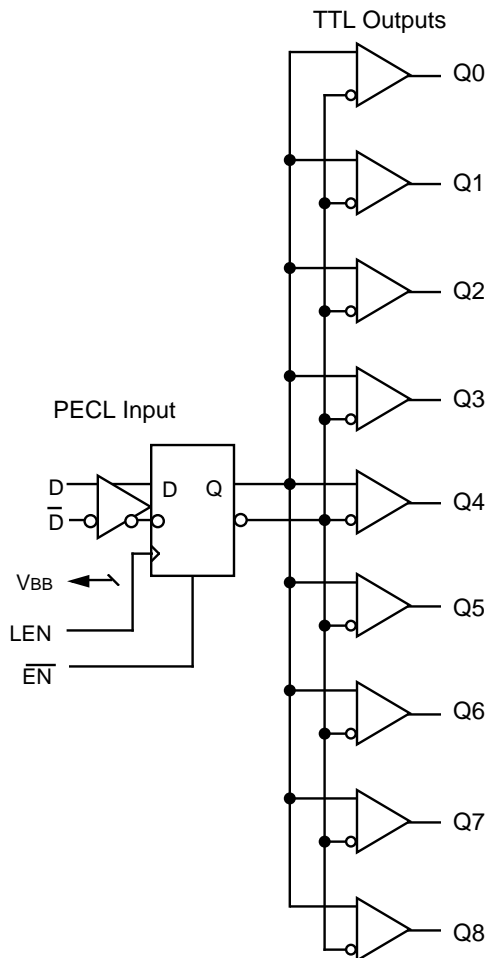

PIN NAMES

Pin	Function
GT	TTL Ground (0V)
VT	TTL Vcc (+5.0V)
VE	ECL Vcc (+5.0V)
GE	ECL Ground (0V)
D, \overline{D}	Signal Input (PECL)
VBB	VBB Reference Output (PECL)
Q0 - Q8	Signal Outputs (TTL)
\overline{EN}	Enable Input (PECL)
LEN	Latch Enable Input (PECL)

PACKAGE/ORDERING INFORMATION

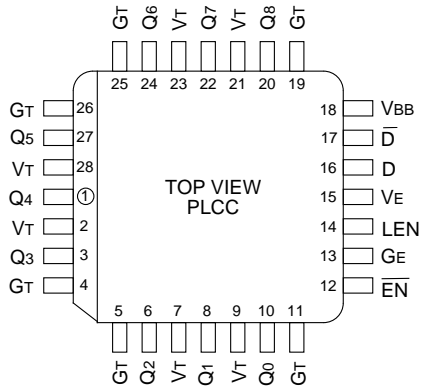

28-Pin PLCC (J28-1)

Ordering Information⁽¹⁾

Part Number	Package Type	Operating Range	Package Marking	Lead Finish
SY10H641JC	J28-1	Commercial	SY10H641JC	Sn-Pb
SY10H641JCTR ⁽²⁾	J28-1	Commercial	SY10H641JC	Sn-Pb
SY100H641JC	J28-1	Commercial	SY100H641JC	Sn-Pb
SY100H641JCTR ⁽²⁾	J28-1	Commercial	SY100H641JC	Sn-Pb
SY10H641JZ ⁽³⁾	J28-1	Commercial	SY10H641JZ with Pb-Free bar-line indicator	Matte-Sn
SY10H641JZTR ^(2, 3)	J28-1	Commercial	SY10H641JZ with Pb-Free bar-line indicator	Matte-Sn
SY100H641JZ ⁽³⁾	J28-1	Commercial	SY100H641JZ with Pb-Free bar-line indicator	Matte-Sn
SY100H641JZTR ^(2, 3)	J28-1	Commercial	SY100H641JZ with Pb-Free bar-line indicator	Matte-Sn

Notes:

1. Contact factory for die availability. Dice are guaranteed at T_A = 25°C, DC Electricals only.
2. Tape and Reel.
3. Pb-Free package is recommended for new designs.

ABSOLUTE MAXIMUM RATINGS⁽¹⁾

Symbol	Rating	Value	Unit
VE (ECL) VT (TTL)	Power Supply Voltage	-0.5 to +7.0 -0.5 to +7.0	V
VI (ECL)	Input Voltage	0.0 to VEE	V
VOUT (TTL)	Disabled 3-State Output	0.0 to VCC	V
IOUT (ECL)	Output Current - Continuous - Surge	50 100	mA
TLEAD	Lead Temperature Range (soldering, 20sec)	+260	°C
Tstore	Storage Temperature	-65 to +150	°C
TA	Operating Temperature	0 to +85	°C

Note:

1. Do not exceed.

TRUTH TABLE

D	LEN	EN	Q
L	L	L	L
H	L	L	H
X	H	L	Q0
X	X	H	L

VCC AND CLOAD

Ranges to meet duty cycle requirement: 0°C ≤ TA ≤ 85°C. Output duty cycle measured relative to 1.5V.

Symbol	Parameter	Min.	Typ.	Max.	Unit	Condition	
PW1	Ranges of VCC and CL to meet min. pulse width (HIGH or LOW) at fOUT ≤ 40MHz	VCC	4.75	5.0	5.25	V	All Outputs
		CL	10	—	50	pF	
		Pw	11	—	—	ns	
PW2	Ranges of VCC and CL to meet min. pulse width (HIGH or LOW) at fOUT ≤ 50MHz	VCC	4.875	5.0	5.125	V	All Outputs
		CL	15	—	27	pF	
		Pw	9.0	—	—	ns	

DC ELECTRICAL CHARACTERISTICS

VT = VE = 5.0V ± 5%

Symbol	Parameter		TA = 0°C		TA = +25°C		TA = +85°C		Unit	Condition
			Min.	Max.	Min.	Max.	Min.	Max.		
IEE	Power Supply Current	ECL	—	30	—	30	—	30	mA	VE Pin
ICCH		TTL	—	30	—	30	—	30		Total all VT pins
ICCL			—	35	—	35	—	35		

TTL DC ELECTRICAL CHARACTERISTICS

VT = VE = 5.0V ± 5%

Symbol	Parameter	TA = 0°C		TA = +25°C		TA = +85°C		Unit	Condition
		Min.	Max.	Min.	Max.	Min.	Max.		
VOH	Output HIGH Voltage	2.0	—	2.0	—	2.0	—	V	IOH = -15mA
VOL	Output LOW Voltage	—	0.5	—	0.5	—	0.5	V	IOL = 24mA
Ios	Output Short Circuit Current	-100	-225	-100	-225	-100	-225	mA	VOUT = 0V

10H ECL DC ELECTRICAL CHARACTERISTICS

VT = VE = 5.0V ± 5%

Symbol	Parameter	TA = 0°C		TA = +25°C		TA = +85°C		Unit	Condition
		Min.	Max.	Min.	Max.	Min.	Max.		
I _{IH}	Input HIGH Current	—	225	—	175	—	175	μA	—
I _{IL}	Input LOW Current	0.5	—	0.5	—	0.5	—	μA	—
V _{IH}	Input HIGH Voltage ⁽¹⁾	3.830	4.160	3.870	4.190	3.940	4.280	V	VE = 5.0V
V _{IL}	Input LOW Voltage ⁽¹⁾	3.050	3.520	3.050	3.520	3.050	3.555	V	VE = 5.0V
V _{BB}	Output Reference Voltage ⁽¹⁾	3.620	3.730	3.650	3.750	3.690	3.810	V	VE = 5.0V

Note:1. V_{IH}, V_{IL} and V_{BB} are referenced to V_E and will vary 1:1 with the power supply. The levels shown are for V_E = +5.0V.**100H ECL DC ELECTRICAL CHARACTERISTICS**

VT = VE = 5.0V ± 5%

Symbol	Parameter	TA = 0°C		TA = +25°C		TA = +85°C		Unit	Condition
		Min.	Max.	Min.	Max.	Min.	Max.		
I _{IH}	Input HIGH Current	—	225	—	175	—	175	μA	—
I _{IL}	Input LOW Current	0.5	—	0.5	—	0.5	—	μA	—
V _{IH}	Input HIGH Voltage ⁽¹⁾	3.835	4.120	3.835	4.120	3.835	4.120	V	VE = 5.0V
V _{IL}	Input LOW Voltage ⁽¹⁾	3.190	3.525	3.190	3.525	3.190	3.525	V	VE = 5.0V
V _{BB}	Output Reference Voltage ⁽¹⁾	3.620	3.740	3.620	3.740	3.620	3.740	V	VE = 5.0V

Note:1. V_{IH}, V_{IL} and V_{BB} are referenced to V_E and will vary 1:1 with the power supply. The levels shown are for V_E = +5.0V.**AC ELECTRICAL CHARACTERISTICS**

VT = VE = 5.0V ± 5%

Symbol	Parameter	TA = 0°C		TA = +25°C		TA = +85°C		Unit	Condition
		Min.	Max.	Min.	Max.	Min.	Max.		
t _{PD}	Propagation Delay D to Output	5.0	6.0	4.8	5.8	5.3	6.3	ns	CL = 50pF
t _{skpp}	Part-to-Part Skew ^(1,4)	—	1.0	—	1.0	—	1.0	ns	CL = 50pF
t _{skew++}	Within-Device Skew ^(2,4)	—	0.5	—	0.5	—	0.5	ns	CL = 50pF
t _{skew--}	Within-Device Skew ^(3,4)	—	0.5	—	0.5	—	0.5	ns	CL = 50pF
t _{PLH} t _{PHL}	Propagation Delay LEN to Output	4.9	6.9	4.9	6.9	5.0	7.0	ns	CL = 50pF
t _{PLH} t _{PHL}	Propagation Delay EN to Output	5.0	7.0	4.9	6.9	5.0	7.0	ns	CL = 50pF
t _r t _f	Output Rise/Fall Time 0.8V to 2.0V	—	1.7	—	1.7	—	1.7	ns	CL = 50pF
f _{MAX}	Maximum Input Frequency ^(5,6)	135	—	135	—	135	—	MHz	CL = 50pF
—	Pulse Width	1.5	—	1.5	—	1.5	—	ns	—
—	Recovery Time	1.25	—	1.25	—	1.25	—	ns	—
t _S	Set-up Time	0.5 (typ.)		0.5 (typ.)		0.5 (typ.)		ns	—
t _H	Hold Time	0.5 (typ.)		0.5 (typ.)		0.5 (typ.)		ns	—

Notes:

- Device-to-Device Skew considering HIGH-to-HIGH transitions at common power supply voltage.
- Within-Device Skew considering HIGH-to-HIGH transitions at common power supply voltage.
- Within-Device Skew considering LOW-to-LOW transitions at common power supply voltage.
- All skew parameters are guaranteed but not tested.
- Frequency at which output levels will meet a 0.8V to 2.0V minimum swing.
- The f_{MAX} value is specified as the minimum guaranteed maximum frequency. Actual operational maximum frequency may be greater.

TTL SWITCHING CIRCUIT

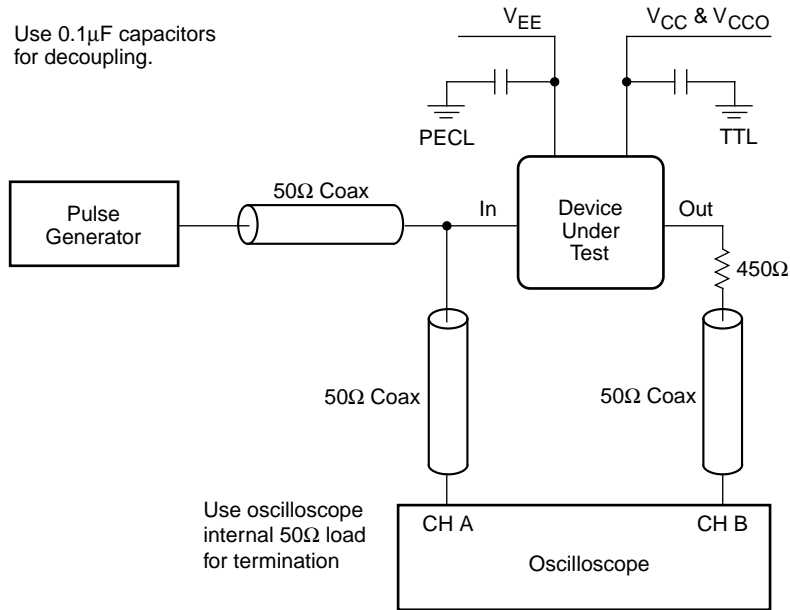

ECL/TTL PROPAGATION DELAY — SINGLE ENDED

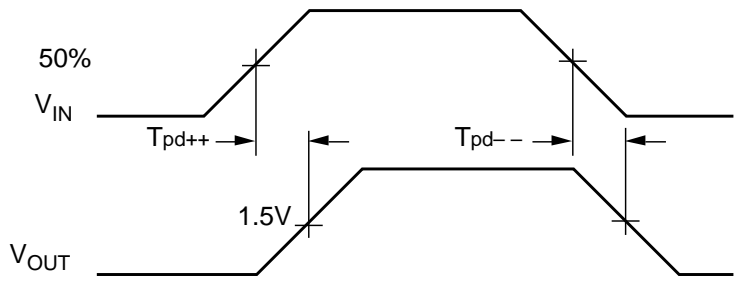

ECL/TTL WAVEFORMS: RISE AND FALL TIMES

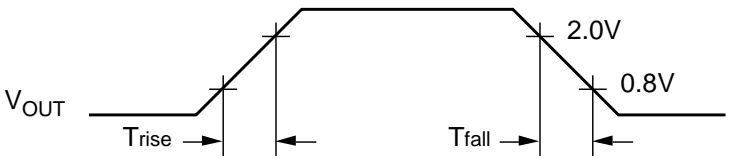

28-PIN PLCC (J28-1)

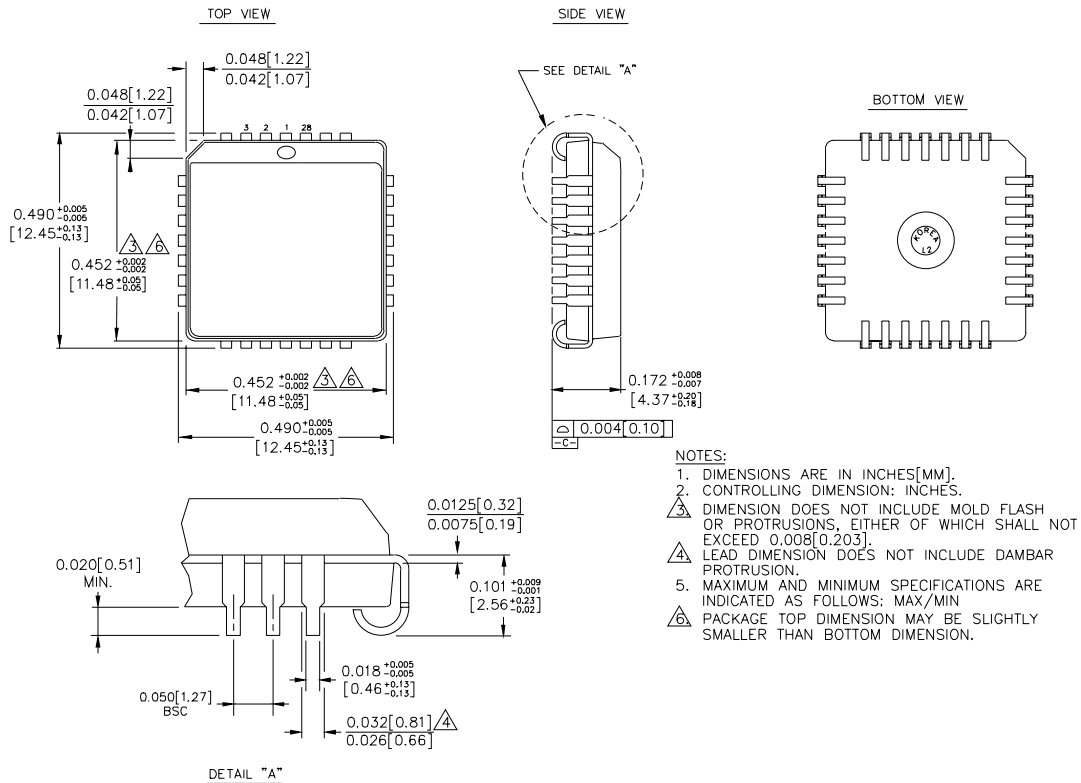

Rev. 03

MICREL, INC. 2180 FORTUNE DRIVE SAN JOSE, CA 95131 USA

TEL + 1 (408) 944-0800 FAX + 1 (408) 474-1000 WEB <http://www.micrel.com>

The information furnished by Micrel in this data sheet is believed to be accurate and reliable. However, no responsibility is assumed by Micrel for its use. Micrel reserves the right to change circuitry and specifications at any time without notification to the customer.

Micrel Products are not designed or authorized for use as components in life support appliances, devices or systems where malfunction of a product can reasonably be expected to result in personal injury. Life support devices or systems are devices or systems that (a) are intended for surgical implant into the body or (b) support or sustain life, and whose failure to perform can be reasonably expected to result in a significant injury to the user. A Purchaser's use or sale of Micrel Products for use in life support appliances, devices or systems is at Purchaser's own risk and Purchaser agrees to fully indemnify Micrel for any damages resulting from such use or sale.

© 2006 Micrel, Incorporated.

X-ON Electronics

Largest Supplier of Electrical and Electronic Components

Click to view similar products for [Translation - Voltage Levels](#) category:

Click to view products by [Micrel](#) manufacturer:

Other Similar products are found below :

[NLSX4373DMR2G](#) [NLSX5012MUTAG](#) [NLSX0102FCT2G](#) [NLSX4302EBMUTCG](#) [PCA9306FMUTAG](#) [MC100EPT622MNG](#)
[NLSX5011MUTCG](#) [NLV9306USG](#) [NLVSX4014MUTAG](#) [NLSV4T3144MUTAG](#) [NLVSX4373MUTAG](#) [MAX3371ELT+T](#)
[NLSX3013BFCT1G](#) [NLV7WBD3125USG](#) [NLSX3012DMR2G](#) [74AVCH1T45FZ4-7](#) [NLVSV1T244MUTBG](#) [74AVC1T45GS-Q100H](#)
[CLVC16T245MDGGREP](#) [MC10H124FNG](#) [CAVCB164245MDGGREP](#) [CD40109BPWR](#) [MC10H350FNG](#) [MC10H125FNG](#)
[MC100EPT21MNR4G](#) [MC100EP91DWG](#) [NLSV2T244MUTAG](#) [NLSX3013FCT1G](#) [NLSX5011AMX1TCG](#) [PCA9306USG](#)
[SN74GTL1655DGGR](#) [SN74AVCA406LZQSR](#) [NLSX4014DTR2G](#) [NLSX3018DTR2G](#) [LTC1045CN#PBF](#) [SY100EL92ZG](#)
[74AXP1T34GMH](#) [74AXP1T34GNH](#) [LSF0204DPWR](#) [PI4ULS3V204LE](#) [ADG3245BRUZ-REEL7](#) [ADG3123BRUZ](#) [ADG3245BRUZ](#)
[ADG3246BCPZ](#) [ADG3308BCPZ-REEL](#) [ADG3233BRJZ-REEL7](#) [ADG3233BRMZ](#) [ADG3241BKSZ-500RL7](#) [ADG3242BRJZ-REEL7](#)
[ADG3243BRJZ-REEL7](#)