



# SY10/100EL11V

## 5V/3.3V 1:2 Differential Fanout Buffer

Revision 10.0

### General Description

The SY10/100EL11V are 1:2 differential fanout gates. These devices are functionally similar to the E111A/L devices, with higher performance capabilities. Having within-device skews and output transition times significantly improved over the E111A/L, the EL11V is ideally suited for those applications which require the ultimate in AC performance.

The differential inputs of the EL11V employ clamping circuitry to maintain stability under open input conditions. If the inputs are left open (pulled to  $V_{EE}$ ), the Q outputs will go LOW.

Datasheets and support documentation are available on Micrel's web site at: [www.micrel.com](http://www.micrel.com).



**Precision Edge**

### Features

- 3.3V and 5V power supply options
- 265ps propagation delay
- 5ps skew between outputs
- High bandwidth output transitions
- Internal 75k $\Omega$  input pull-down resistors
- Replaces SY10/100EL11
- Improved output waveform characteristics
- Available in 8-pin SOIC package

### Pin Names

Pin	Function
D	Data Inputs
Q <sub>0</sub> , Q <sub>1</sub>	Data Outputs

Precision is a registered trademark of Micrel, Inc.

Micrel Inc. • 2180 Fortune Drive • San Jose, CA 95131 • USA • tel +1 (408) 944-0800 • fax + 1 (408) 474-1000 • <http://www.micrel.com>

August 1, 2014

080114-10.0

[tcghelp@micrel.com](mailto:tcghelp@micrel.com) or (408) 955-1690

## Ordering Information<sup>(1)</sup>

Part Number	Package Type	Operating Range	Package Marking	Lead Finish
SY10EL11VZG	Z8-1	Industrial	HEL11V with Pb-Free bar-line indicator	Pb-Free NiPdAu
SY10EL11VZG TR <sup>(2)</sup>	Z8-1	Industrial	HEL11V with Pb-Free bar-line indicator	Pb-Free NiPdAu
SY100EL11V	Z8-1	Industrial	XEL11V with Pb-Free bar-line indicator	Pb-Free NiPdAu
SY100EL11VZG TR <sup>(2)</sup>	Z8-1	Industrial	XEL11V with Pb-Free bar-line indicator	Pb-Free NiPdAu

**Note:**

1. Contact factory for die availability. Dice are guaranteed at T<sub>A</sub> = 25°C, DC Electricals only.
2. Tape and Reel.

## Pin Configuration

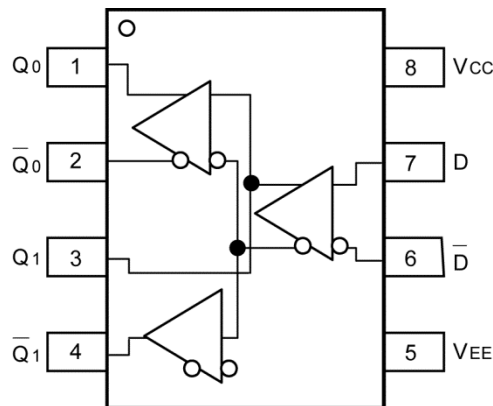

8-Pin SOIC (Z8-1)

**Absolute Maximum Ratings<sup>(3)</sup>**

Power Supply Voltage ( $V_{EE} = 0V$ ).....	0V to +6V
Power Supply Voltage ( $V_{CC} = 0V$ ) .....	-6V to +0V
Input Voltage ( $V_{IN}$ )	
( $V_{CC} = 0V$ , $V_{IN}$ not more positive than $V_{EE}$ )....	-6V to +0V
( $V_{EE} = 0V$ , $V_{IN}$ not more positive than $V_{CC}$ )...	+0V to +6V
Output Current ( $I_{OUT}$ )	
Continuous.....	50mA
Surge .....	100mA
Lead Temperature Range (soldering, 20s).....	260°C
Storage Temperature ( $T_s$ ) .....	-65 to +150°C
ESD Rating <sup>(5)</sup> .....	>1.5kV

**Operating Ratings<sup>(4)</sup>**

Supply Voltage ( $V_{CC}$ ).....	3.0V to 5.5V
Ambient Temperature ( $T_A$ ) .....	-40°C to +85°C
Junction Thermal Resistance	
Junction-to-Ambient ( $\theta_{JA}$ )	
Still Air .....	98.9°C/W
Junction-to-Case ( $\theta_{JC}$ ) .....	48.8°C/W

**10K Series DC Electrical Characteristics<sup>(6,7)</sup>**

$V_{CC} = 3.0V$  to  $5.5V$ ,  $V_{EE} = 0V$ ,  $T_A = -40^\circ C$  to  $+85^\circ C$ ,  $R_L = 50\Omega$  to  $V_{CC} - 2V$ , unless otherwise stated.

Symbol	Parameter	Condition	Min.	Max.	Units
$V_{OH}$	Output HIGH Voltage	$T_A = -40^\circ C$	$V_{CC} - 1.080$	$V_{CC} - 0.890$	V
		$T_A = 0^\circ C$	$V_{CC} - 1.020$	$V_{CC} - 0.840$	
		$T_A = +25^\circ C$	$V_{CC} - 0.980$	$V_{CC} - 0.810$	
		$T_A = +85^\circ C$	$V_{CC} - 0.910$	$V_{CC} - 0.720$	
$V_{OL}$	Output LOW Voltage	$T_A = -40^\circ C$	$V_{CC} - 1.950$	$V_{CC} - 1.650$	V
		$T_A = 0^\circ C$	$V_{CC} - 1.950$	$V_{CC} - 1.630$	
		$T_A = +25^\circ C$	$V_{CC} - 1.950$	$V_{CC} - 1.630$	
		$T_A = +85^\circ C$	$V_{CC} - 1.950$	$V_{CC} - 1.595$	
$V_{IH}$	Input HIGH Voltage	$T_A = -40^\circ C$	$V_{CC} - 1.230$	$V_{CC} - 0.890$	V
		$T_A = 0^\circ C$	$V_{CC} - 1.170$	$V_{CC} - 0.840$	
		$T_A = +25^\circ C$	$V_{CC} - 1.130$	$V_{CC} - 0.810$	
		$T_A = +85^\circ C$	$V_{CC} - 1.060$	$V_{CC} - 0.720$	
$V_{IL}$	Input LOW Voltage	$T_A = -40^\circ C$	$V_{CC} - 1.950$	$V_{CC} - 1.500$	V
		$T_A = 0^\circ C$	$V_{CC} - 1.950$	$V_{CC} - 1.480$	
		$T_A = +25^\circ C$	$V_{CC} - 1.950$	$V_{CC} - 1.480$	
		$T_A = +85^\circ C$	$V_{CC} - 1.950$	$V_{CC} - 1.445$	
$I_{IH}$	Input HIGH Current	$T_A = -40^\circ C$ to $+85^\circ C$		150	$\mu A$
$I_{IL}$	Input LOW Current	$T_A = -40^\circ C$ to $+85^\circ C$	0.5		$\mu A$

## 100K Series DC Electrical Characteristics<sup>(6)</sup>

$V_{CC} = 3.0V$  to  $5.5V$ ,  $V_{EE} = 0V$ ,  $T_A = -40^{\circ}C$  to  $+85^{\circ}C$ ,  $R_L = 50\Omega$  to  $V_{CC} - 2V$ , unless otherwise stated.

Symbol	Parameter	Condition	Min.	Typ.	Max.	Units
$V_{OH}$	Output HIGH Voltage	$T_A = -40^{\circ}C$ , $V_{IN} = V_{IH}$ (Max) or $V_{IL}$ (Min)	$V_{CC} - 1.085$	$V_{CC} - 1.005$	$V_{CC} - 0.880$	V
		$T_A = 0^{\circ}C$ to $+85^{\circ}C$ , $V_{IN} = V_{IH}$ (Max) or $V_{IL}$ (Min)	$V_{CC} - 1.025$	$V_{CC} - 0.955$	$V_{CC} - 0.880$	
$V_{OL}$	Output LOW Voltage	$T_A = -40^{\circ}C$ , $V_{IN} = V_{IH}$ (Max) or $V_{IL}$ (Min)	$V_{CC} - 1.830$	$V_{CC} - 1.695$	$V_{CC} - 1.555$	V
		$T_A = 0^{\circ}C$ to $+85^{\circ}C$ , $V_{IN} = V_{IH}$ (Max) or $V_{IL}$ (Min)	$V_{CC} - 1.810$	$V_{CC} - 1.705$	$V_{CC} - 1.620$	
$V_{IH}$	Input HIGH Voltage <sup>(9)</sup>	$T_A = -40^{\circ}C$ to $+85^{\circ}C$	$V_{CC} - 1.165$		$V_{CC} - 0.880$	V
$V_{IL}$	Input LOW Voltage <sup>(10)</sup>	$T_A = -40^{\circ}C$ to $+85^{\circ}C$	$V_{CC} - 1.810$		$V_{CC} - 1.475$	V
$I_{IH}$	Input HIGH Current	$T_A = -40^{\circ}C$ to $+85^{\circ}C$			150	$\mu A$
$I_{IL}$	Input LOW Current	$T_A = -40^{\circ}C$ to $+85^{\circ}C$ , $V_{IN} = V_{IL}$ (Min)	0.5			$\mu A$

### Notes:

- Permanent device damage may occur if absolute maximum ratings are exceeded. This is a stress rating only and functional operation is not implied at conditions other than those detailed in the operational sections of this data sheet. Exposure to absolute maximum rating conditions for extended periods may affect device reliability.
- The device is not guaranteed to function outside its operating ratings.
- Devices are ESD sensitive. Handling precautions are recommended. Human body model, 1.5k in series with 100pF.
- Specification for packaged product only
- 10EL circuits are designed to meet the DC specifications shown in the table after thermal equilibrium has been established. The circuit is in a test socket or mounted on a printed circuit board and transverse airflow greater than 500 lfpm is maintained. Outputs are terminated through a  $50\Omega$  resistor to  $V_{CC} - 2.0V$  except where otherwise specified.
- This table replaces the three tables traditionally seen in ECL 100K data books. The same DC parameter values at  $V_{EE} = -4.5V$  now apply across the full  $V_{EE}$  range of  $-4.2V$  to  $-5.5V$ . Outputs are terminated through a  $50\Omega$  resistor to  $-2.0V$  except where otherwise specified. 100K circuits are designed to meet the DC specifications shown in the table after thermal equilibrium has been established and where transverse airflow greater than 500 lfpm is maintained.
- Guaranteed HIGH Signal for all Inputs.
- Guaranteed LOW Signal for all Inputs.

**10K Series DC Electrical Characteristics**<sup>(6,7,8)</sup>

$V_{CC} = 0$ ,  $V_{EE} = -3.0V$  to  $-5.5V$ ,  $T_A = -40^{\circ}C$  to  $+85^{\circ}C$ ,  $R_L = 50\Omega$  to  $V_{CC} - 2V$ , unless otherwise stated.

Symbol	Parameter	Condition	Min.	Max.	Units
$V_{OH}$	Output HIGH Voltage	$T_A = -40^{\circ}C$	$V_{CC} - 1.080$	$V_{CC} - 0.890$	V
		$T_A = 0^{\circ}C$	$V_{CC} - 1.020$	$V_{CC} - 0.840$	
		$T_A = +25^{\circ}C$	$V_{CC} - 0.980$	$V_{CC} - 0.810$	
		$T_A = +85^{\circ}C$	$V_{CC} - 0.910$	$V_{CC} - 0.720$	
$V_{OL}$	Output LOW Voltage	$T_A = -40^{\circ}C$	$V_{CC} - 1.950$	$V_{CC} - 1.650$	V
		$T_A = 0^{\circ}C$	$V_{CC} - 1.950$	$V_{CC} - 1.630$	
		$T_A = +25^{\circ}C$	$V_{CC} - 1.950$	$V_{CC} - 1.630$	
		$T_A = +85^{\circ}C$	$V_{CC} - 1.950$	$V_{CC} - 1.595$	
$V_{IH}$	Input HIGH Voltage <sup>(9)</sup>	$T_A = -40^{\circ}C$	$V_{CC} - 1.230$	$V_{CC} - 0.890$	V
		$T_A = 0^{\circ}C$	$V_{CC} - 1.170$	$V_{CC} - 0.840$	
		$T_A = +25^{\circ}C$	$V_{CC} - 1.130$	$V_{CC} - 0.810$	
		$T_A = +85^{\circ}C$	$V_{CC} - 1.060$	$V_{CC} - 0.720$	
$V_{IL}$	Input LOW Voltage <sup>(10)</sup>	$T_A = -40^{\circ}C$	$V_{CC} - 1.950$	$V_{CC} - 1.500$	V
		$T_A = 0^{\circ}C$	$V_{CC} - 1.950$	$V_{CC} - 1.480$	
		$T_A = +25^{\circ}C$	$V_{CC} - 1.950$	$V_{CC} - 1.480$	
		$T_A = +85^{\circ}C$	$V_{CC} - 1.950$	$V_{CC} - 1.445$	
$I_{IH}$	Input HIGH Current	$T_A = -40^{\circ}C$ to $+85^{\circ}C$		150	$\mu A$
$I_{IL}$	Input LOW Current	$T_A = -40^{\circ}C$ to $+85^{\circ}C$	0.5		$\mu A$

**100K Series DC Electrical Characteristics<sup>(6,8)</sup>**

$V_{CC} = 0$ ,  $V_{EE} = -3.0V$  to  $-5.5V$ ,  $T_A = -40^{\circ}C$  to  $+85^{\circ}C$ ,  $R_L = 50\Omega$  to  $V_{CC} - 2V$ , unless otherwise stated.

Symbol	Parameter	Condition	Min.	Typ.	Max.	Units
$V_{OH}$	Output HIGH Voltage	$T_A = -40^{\circ}C$ , $V_{IN} = V_{IH}$ (Max) or $V_{IL}$ (Min)	$V_{CC} - 1.085$	$V_{CC} - 1.005$	$V_{CC} - 0.880$	V
		$T_A = 0^{\circ}C$ to $+85^{\circ}C$ , $V_{IN} = V_{IH}$ (Max) or $V_{IL}$ (Min)	$V_{CC} - 1.025$	$V_{CC} - 0.955$	$V_{CC} - 0.880$	
$V_{OL}$	Output LOW Voltage	$T_A = -40^{\circ}C$ , $V_{IN} = V_{IH}$ (Max) or $V_{IL}$ (Min)	$V_{CC} - 1.830$	$V_{CC} - 1.695$	$V_{CC} - 1.555$	V
		$T_A = 0^{\circ}C$ to $+85^{\circ}C$ , $V_{IN} = V_{IH}$ (Max) or $V_{IL}$ (Min)	$V_{CC} - 1.810$	$V_{CC} - 1.705$	$V_{CC} - 1.620$	
$V_{IH}$	Input HIGH Voltage <sup>(9)</sup>	$T_A = -40^{\circ}C$ to $+85^{\circ}C$	$V_{CC} - 1.165$		$V_{CC} - 0.880$	V
$V_{IL}$	Input LOW Voltage <sup>(10)</sup>	$T_A = -40^{\circ}C$ to $+85^{\circ}C$	$V_{CC} - 1.810$		$V_{CC} - 1.475$	V
$I_{IH}$	Input HIGH Current	$T_A = -40^{\circ}C$ to $+85^{\circ}C$			150	$\mu A$
$I_{IL}$	Input LOW Current	$T_A = -40^{\circ}C$ to $+85^{\circ}C$ , $V_{IN} = V_{IL}$ (Min)	0.5			$\mu A$

## AC Electrical Characteristics<sup>(11)</sup>

$V_{CC} - V_{EE} = 3.0V$  to  $5.5V$ ,  $T_A = -40^{\circ}C$  to  $+85^{\circ}C$ ,  $R_L = 50\Omega$  to  $V_{CC} - 2V$ , unless otherwise stated.

Symbol	Parameter	Condition	Min.	Typ.	Max.	Units
$f_{max}$	Maximum Frequency		750			MHz
$t_{PLH}$ $t_{PHL}$	Propagation Delay to Output D	$T_A = -40^{\circ}C$	135	260	385	ps
		$T_A = 0^{\circ}C$	185	260	335	
		$T_A = +25^{\circ}C$	190	265	340	
		$T_A = +85^{\circ}C$	215	290	365	
$t_{skew}$	Within-Device Skew <sup>(12)</sup> Duty Cycle Skew <sup>(13)</sup>	$T_A = -40^{\circ}C$		5		ps
		$T_A = 0^{\circ}C$ to $+85^{\circ}C$		5	20	
$T_{JITTER}$	Additive Phase Jitter (RMS)	Carrier = 622MHz Integration Range: 12kHz – 20MHz $T_A = +25^{\circ}C$		28		fs <sub>RMS</sub>
$V_{PP}$	Minimum Input Swing <sup>(14)</sup>	$T_A = -40^{\circ}C$ to $+85^{\circ}C$	150			mV
$V_{CMR}$	Common Mode Range <sup>(15)</sup>	$T_A = -40^{\circ}C$	$V_{CC} - 1.300$		$V_{CC} - 0.400$	$\mu A$
		$T_A = 0^{\circ}C$ to $+85^{\circ}C$	$V_{CC} - 1.400$		$V_{CC} - 0.400$	$\mu A$
$t_r$ $t_f$	Output Rise/Fall Times Q (20% to 80%)	$T_A = -40^{\circ}C$ to $+85^{\circ}C$	100	225	350	ps

### Notes:

- Parametric values specified at:  $-3.0V$  to  $-5.5V$ .
- Within-device skew defined as identical transitions on similar paths through a device.
- Duty cycle skew is the difference between a  $t_{PLH}$  and  $t_{PHL}$  propagation delay through a device.
- Minimum input swing for which AC parameters are guaranteed. The device has a DC gain of 40.
- The CMR range is referenced to the most positive side of the differential input signal. Normal operation is obtained if the HIGH level falls within the specified range and the peak-to-peak voltage lies between  $V_{PP}$  min. and  $1V$ . The lower end of the CMR range varies 1:1 with  $V_{EE}$ . The numbers in the spec table assume a nominal  $V_{EE} = -3.3V$ . Note for PECL operation, the  $V_{CMR(min)}$  will be fixed at  $3.3V - |V_{CMR(min)}|$ .

### Additive Phase Noise Plot

V<sub>CC</sub> = 3.3V, T<sub>A</sub> = +25°C.

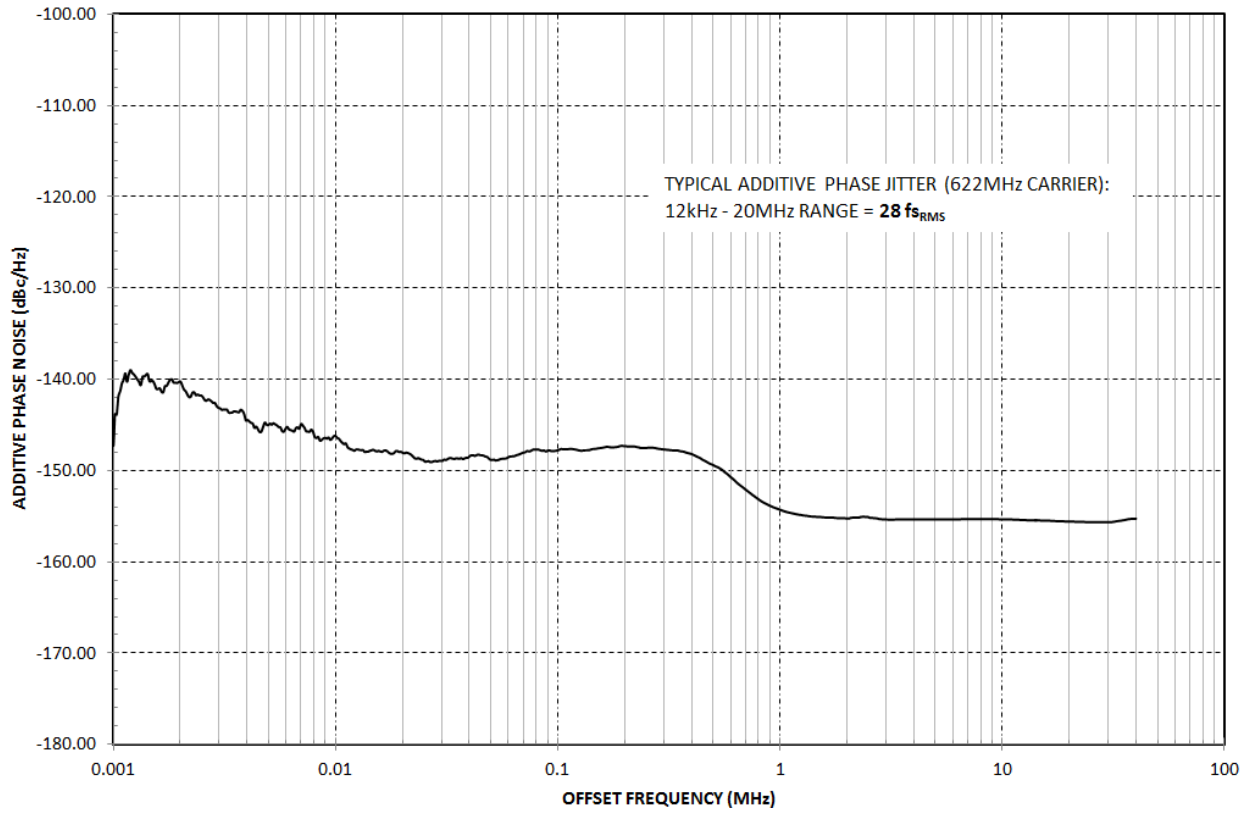



Package Information<sup>(16)</sup>

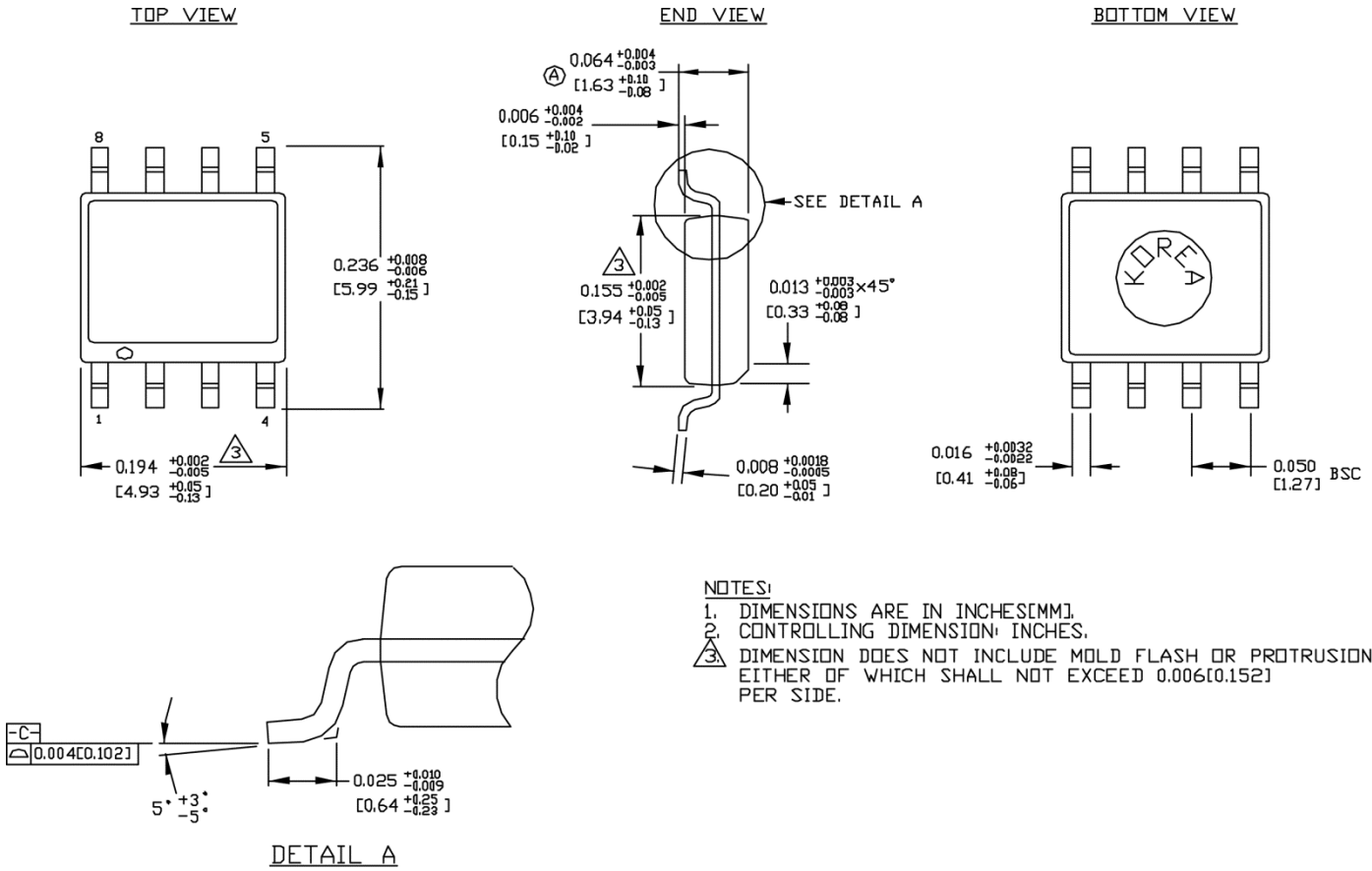

8-Pin SOIC (Z8-1)

Note:

16. Package information is correct as of the publication date. For updates and most current information, go to [www.micrel.com](http://www.micrel.com).

**MICREL, INC. 2180 FORTUNE DRIVE SAN JOSE, CA 95131 USA**  
 TEL +1 (408) 944-0800 FAX +1 (408) 474-1000 WEB <http://www.micrel.com>

Micrel makes no representations or warranties with respect to the accuracy or completeness of the information furnished in this data sheet. This information is not intended as a warranty and Micrel does not assume responsibility for its use. Micrel reserves the right to change circuitry, specifications and descriptions at any time without notice. No license, whether express, implied, arising by estoppel or otherwise, to any intellectual property rights is granted by this document. Except as provided in Micrel's terms and conditions of sale for such products, Micrel assumes no liability whatsoever, and Micrel disclaims any express or implied warranty relating to the sale and/or use of Micrel products including liability or warranties relating to fitness for a particular purpose, merchantability, or infringement of any patent, copyright or other intellectual property right.

Micrel Products are not designed or authorized for use as components in life support appliances, devices or systems where malfunction of a product can reasonably be expected to result in personal injury. Life support devices or systems are devices or systems that (a) are intended for surgical implant into the body or (b) support or sustain life, and whose failure to perform can be reasonably expected to result in a significant injury to the user. A Purchaser's use or sale of Micrel Products for use in life support appliances, devices or systems is a Purchaser's own risk and Purchaser agrees to fully indemnify Micrel for any damages resulting from such use or sale.

© 2014 Micrel, Incorporated.

**Revision History**

Date	Change Description/Edits by:	Rev.
7/15/2014	Complete Reflow. D. Tanabe	10
7/29/2014	Specs edited, Additive Phase Noise included. K. Carreon	11

## X-ON Electronics

Largest Supplier of Electrical and Electronic Components

*Click to view similar products for [Buffers & Line Drivers](#) category:*

*Click to view products by [Micrel](#) manufacturer:*

Other Similar products are found below :

[LXV200-024SW](#) [74AUP2G34FW3-7](#) [HEF4043BP](#) [PI74FCT3244L](#) [MC74HCT365ADTR2G](#) [Le87401NQC](#) [Le87402MQC](#) [028192B](#)  
[042140C](#) [051117G](#) [070519XB](#) [NL17SZ07P5T5G](#) [NLU1GT126AMUTCG](#) [74AUP1G17FW5-7](#) [74LVC2G17FW4-7](#) [CD4502BE](#) [5962-](#)  
[8982101PA](#) [5962-9052201PA](#) [74LVC1G125FW4-7](#) [NL17SH17P5T5G](#) [NL17SH125P5T5G](#) [NLV37WZ07USG](#) [74VHC541FT\(BE\)](#)  
[RHRXH162244K1](#) [74AUP1G34FW5-7](#) [74AUP1G07FW5-7](#) [74LVC1G126FW4-7](#) [74LVC2G126RA3-7](#) [NLX2G17CMUTCG](#)  
[74LVCE1G125FZ4-7](#) [Le87501NQC](#) [74AUP1G126FW5-7](#) [TC74HC4050AP\(F\)](#) [74LVCE1G07FZ4-7](#) [NLX3G16DMUTCG](#)  
[NLX2G06AMUTCG](#) [NLVVHC1G50DFT2G](#) [LE87100NQC](#) [LE87290YQC](#) [LE87290YQCT](#) [LE87511NQC](#) [LE87511NQCT](#) [LE87557NQC](#)  
[LE87557NQCT](#) [LE87614MQC](#) [LE87614MQCT](#) [74AUP1G125FW5-7](#) [NLU2G16CMUTCG](#) [MC74LCX244MN2TWG](#) [NL17SG126DFT2G](#)