

**FEATURES**

- 375ps propagation delay
- 1.6V output swings
- Internal 75KΩ input pull-down resistors
- Available in 8-pin SOIC package

**DESCRIPTION**

The SY10EL89 is a differential fanout gate specifically designed to drive coaxial cables. The device is especially useful in Digital Video Broadcast applications. For this application, since the system is polarity-free, each output of the device can be used as an independent driver. The driver boasts a voltage gain of approximately 40 and produces output swings twice as large as a standard ECL output. When driving a coaxial cable, proper termination is required at both ends of the line to minimize signal loss. The 1.6V output swings allow for termination at both ends of the cable while maintaining the required 800mV swing at the receiving end of the cable. Because of the larger output swings, the device cannot be terminated into the standard -2.0V. All of the DC parameters are tested with a 50Ω to -3.0V load. The driver accepts a standard differential ECL input and can run off the Digital Video Broadcast standard -5.0V supply.

**PIN CONFIGURATION/BLOCK DIAGRAM**

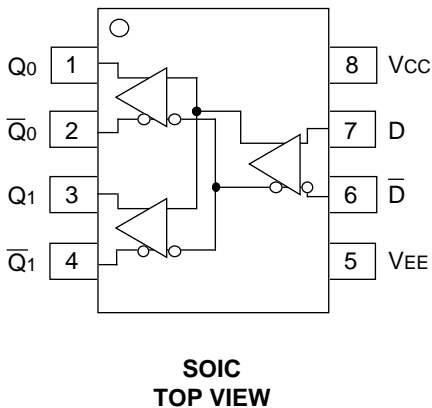

**PIN NAMES**

Pin	Function
D	Data Inputs
Q0, Q1	Data Outputs

**DC ELECTRICAL CHARACTERISTICS**
 $V_{EE} = V_{EE} \text{ (Min.) to } V_{EE} \text{ (Max.); } V_{CC} = \text{GND}$ 

Symbol	Parameter	$T_A = -40^\circ\text{C}$			$T_A = 0^\circ\text{C}$			$T_A = +25^\circ\text{C}$			$T_A = +85^\circ\text{C}$			Unit
		Min.	Typ.	Max.	Min.	Typ.	Max.	Min.	Typ.	Max.	Min.	Typ.	Max.	
$I_{EE}$	Power Supply Current	18	23	28	18	23	28	18	23	28	18	23	28	mA
$V_{OH}$	Output HIGH Voltage <sup>(1)</sup>	-1.23	-1.10	-0.98	-1.17	-1.05	-0.93	-1.13	-1.02	-0.90	-1.06	-0.96	-0.81	V
$V_{OL}$	Output LOW Voltage <sup>(1)</sup>	-2.84	-2.72	-2.58	-2.84	-2.70	-2.56	-2.84	-2.70	-2.56	-2.84	-2.67	-2.51	V
$V_{EE}$	Power Supply Voltage	-4.75	—	-5.5	-4.75	—	-5.5	-4.75	—	-5.5	-4.75	—	-5.5	V
$I_{IH}$	Input HIGH Current	—	—	150	—	—	150	—	—	150	—	—	150	$\mu\text{A}$

**NOTE:**

- $V_{OH}$  and  $V_{OL}$  specified for  $50\Omega$  to  $-3.0\text{V}$  load.

**AC ELECTRICAL CHARACTERISTICS**
 $V_{EE} = V_{EE} \text{ (Min.) to } V_{EE} \text{ (Max.); } V_{CC} = \text{GND}$ 

Symbol	Parameter	$T_A = -40^\circ\text{C}$			$T_A = 0^\circ\text{C}$			$T_A = +25^\circ\text{C}$			$T_A = +85^\circ\text{C}$			Unit
		Min.	Typ.	Max.	Min.	Typ.	Max.	Min.	Typ.	Max.	Min.	Typ.	Max.	
$t_{PLH}$ $t_{PHL}$	Propagation Delay to Output D	200	340	480	250	340	430	260	350	440	310	400	490	ps
$t_{skew}$	Within-Device Skew	—	5	20	—	5	20	—	5	20	—	5	20	ps
$V_{PP}$	Minimum Input Swing <sup>(1)</sup>	150	—	—	150	—	—	150	—	—	150	—	—	mV
$V_{CMR}$	Common Mode Range <sup>(2)</sup>	(2)	—	-0.4	(2)	—	-0.4	(2)	—	-0.4	(2)	—	-0.4	V
$t_r$ $t_f$	Output Rise/Fall Times Q (20% to 80%)	205	330	455	205	330	455	205	330	455	205	330	455	ps

**NOTES:**

- Minimum input swing for which AC parameters are guaranteed. The device has a DC gain of  $\approx 40$ .
- The CMR range is referenced to the most positive side of the differential input signal. Normal operation is obtained if the HIGH level falls within the specified range and the peak-to-peak voltage lies between  $V_{PP}$  (Min.) and  $1\text{V}$ . The lower end of the CMR range is dependent on  $V_{EE}$  and is equal to  $V_{EE} + 2.5\text{V}$ .

**DC BLOCKING CAPACITORS**

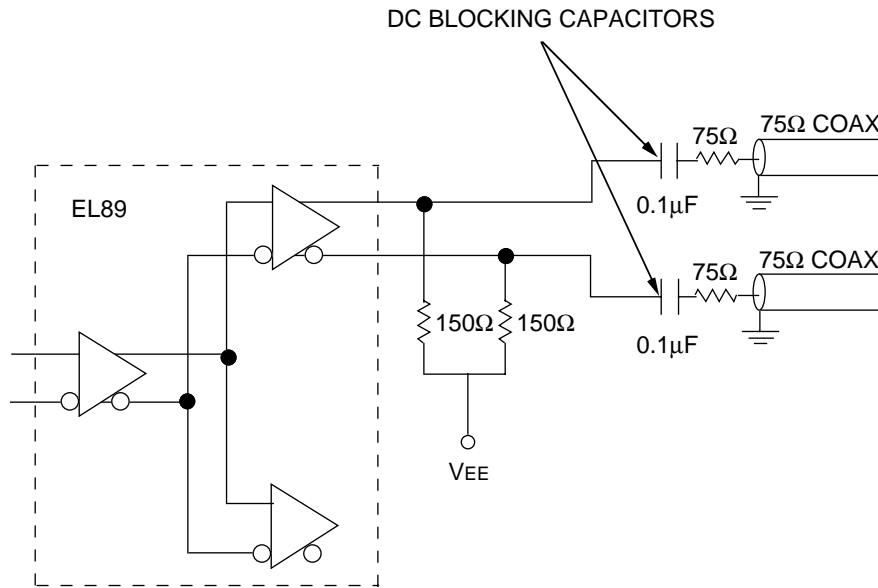

Figure 1. Termination Configuration

**PRODUCT ORDERING CODE**

Ordering Code	Package Type	Operating Range	Marking Code
SY10EL89ZC	Z8-1	Commercial	HEL89
SY10EL89ZCTR*	Z8-1	Commercial	HEL89

Ordering Code	Package Type	Operating Range	Marking Code
SY10EL89ZI <sup>(1)</sup>	Z8-1	Industrial	HEL89
SY10EL89ZITR* <sup>(1)</sup>	Z8-1	Industrial	HEL89

\*Tape and Reel

**Note 1.** Recommended for new designs.

**8 LEAD SOIC .150" WIDE (Z8-1)**

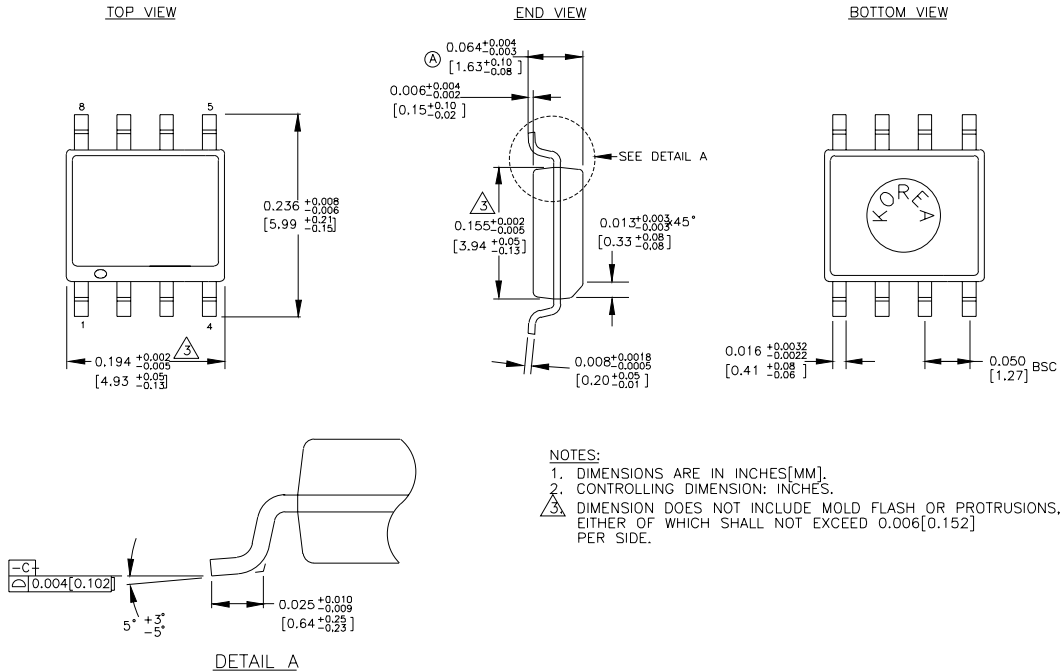

Rev. 03

**MICREL, INC. 1849 FORTUNE DRIVE SAN JOSE, CA 95131 USA**

TEL + 1 (408) 944-0800 FAX + 1 (408) 944-0970 WEB <http://www.micrel.com>

The information furnished by Micrel in this datasheet is believed to be accurate and reliable. However, no responsibility is assumed by Micrel for its use. Micrel reserves the right to change circuitry and specifications at any time without notification to the customer.

Micrel Products are not designed or authorized for use as components in life support appliances, devices or systems where malfunction of a product can reasonably be expected to result in personal injury. Life support devices or systems are devices or systems that (a) are intended for surgical implant into the body or (b) support or sustain life, and whose failure to perform can be reasonably expected to result in a significant injury to the user. A Purchaser's use or sale of Micrel Products for use in life support appliances, devices or systems is at Purchaser's own risk and Purchaser agrees to fully indemnify Micrel for any damages resulting from such use or sale.

© 2003 Micrel, Incorporated.

## X-ON Electronics

Largest Supplier of Electrical and Electronic Components

*Click to view similar products for [Buffers & Line Drivers](#) category:*

*Click to view products by [Micrel](#) manufacturer:*

Other Similar products are found below :

[LXV200-024SW](#) [74AUP2G34FW3-7](#) [HEF4043BP](#) [PI74FCT3244L](#) [MC74HCT365ADTR2G](#) [Le87401NQC](#) [Le87402MQC](#) [028192B](#)  
[042140C](#) [051117G](#) [070519XB](#) [NL17SZ07P5T5G](#) [NLU1GT126AMUTCG](#) [74AUP1G17FW5-7](#) [74LVC2G17FW4-7](#) [CD4502BE](#) [5962-](#)  
[8982101PA](#) [5962-9052201PA](#) [74LVC1G125FW4-7](#) [NL17SH17P5T5G](#) [NL17SH125P5T5G](#) [NLV37WZ07USG](#) [RHRXH162244K1](#)  
[74AUP1G34FW5-7](#) [74AUP1G07FW5-7](#) [74LVC2G126RA3-7](#) [NLX2G17CMUTCG](#) [74LVCE1G125FZ4-7](#) [Le87501NQC](#) [74AUP1G126FW5-](#)  
[7](#) [TC74HC4050AP\(F\)](#) [74LVCE1G07FZ4-7](#) [NLX3G16DMUTCG](#) [NLX2G06AMUTCG](#) [NLVVHC1G50DFT2G](#) [LE87100NQC](#)  
[LE87290YQC](#) [LE87290YQCT](#) [LE87511NQC](#) [LE87511NQCT](#) [LE87557NQC](#) [LE87557NQCT](#) [LE87614MQC](#) [LE87614MQCT](#)  
[74AUP1G125FW5-7](#) [NLU2G16CMUTCG](#) [MC74LCX244MN2TWG](#) [NL17SG126DFT2G](#) [NLVHCT245ADTR2G](#) [NLV37WZ16USG](#)