

µC/TCP-IP™ Protocol Stack

DESCRIPTION

µC/TCP-IP is a compact, reliable, high-performance TCP/IP protocol stack, optimized for embedded systems. Built from the ground up with Micrium quality and scalability, µC/TCP-IP enables rapid configuration of required network options to minimize time-to-market.

µC/TCP-IP allows for adjustment of the memory footprint based on design requirements. µC/TCP-IP can be configured to include only needed network modules. When a module is not used, it is not included in the build, saving valuable memory space.

µC/TCP-IP's design introduces a new concept: Large and small buffers. A large buffer is of the size required to transport a complete Ethernet frame. This is what other TCP/IP stacks do. But, in an embedded system, it is quite possible that the amount of information to transmit and receive does not require the use of a full Ethernet frame. In this case using buffers of the size of full Ethernet frames is a waste of RAM. µC/TCP-IP allows the designer to maximize the system performance by defining different quantities of small and large buffers.

µC/TCP-IP requires the presence of an RTOS for task scheduling and mutual exclusion. To meet this requirement, Micrium provides source code to allow network applications to readily accommodate µC/OS-II and µC/OS-III. Based on the module's ostensible Kernel interface, other Kernels can also be adapted to µC/TCP-IP.

µC/TCP-IP can be used on 16-, 32-, and even 64-bit CPUs or DSPs.

APPLICATIONS

The source code for µC/TCP-IP is an extremely robust and highly reliable TCP/IP solution. µC/TCP-IP is designed to be certifiable for use in avionics, compliant for use in FDA-certified devices, and in other safety-critical products.

FEATURES

- Memory footprint is adjustable
- Flexibility to select large and small buffers
- RTOS required: µC/OS-II, µC/OS-III, or other
- Zero copy buffer management
- High performance
- ANSI C source code
- Supports multiple NIC interfaces

PERFORMANCE

In order to meet the demanding requirements of embedded systems, with µC/TCP-IP critical sections are kept to a minimum, while selected run-time validations can be disabled to enhance performance. µC/TCP-IP implements zero copy buffer management for greatest efficiency. With µC/TCP-IP, the full advantage of high-performance DMA is enabled. Ethernet controllers can be harnessed so that TCP/IP stack is a true ZERO COPY stack.

SUPPORT

- µC/TCP-IP currently supports multiple simultaneous Network Interface Controller (NIC) interfaces
- µC/TCP-IP supports Ethernet and wireless NICs.
- Additional drivers are added on a regular basis. Check Micrium.com for a complete list of drivers.

APPLICATION ADD-ON MODULES

µC/DHCPc	Dynamic Host Configuration Protocol (client)
µC/DNSc	Domain Name System (client)
µC/FTPc	File Transfer Protocol (client)
µC/FTPc	File Transfer Protocol (server)
µC/HTTPc	HyperText Transport Protocol (server) a.k.a. Webserver
µC/POP3c	Post Office Protocol (client)
µC/SMTPc	Simple Mail Transfer Protocol (client)
µC/SNTPc	Simple Network Time Protocol (client)
µC/TFTPc	Trivial File Transfer Protocol (client)
µC/TFTPc	Trivial File Transfer Protocol (server)
µC/TELNETc	Telnet (server)

The table above lists the application modules available from Micrium. The lowercase "c" or "s" at the end of the product name represents the Client version or Server version of the module. Any application modules following the Berkeley 4.4 (BSD) socket interface can be used with µC/TCP-IP.

Micrium

μC/TCP-IP ARCHITECTURE

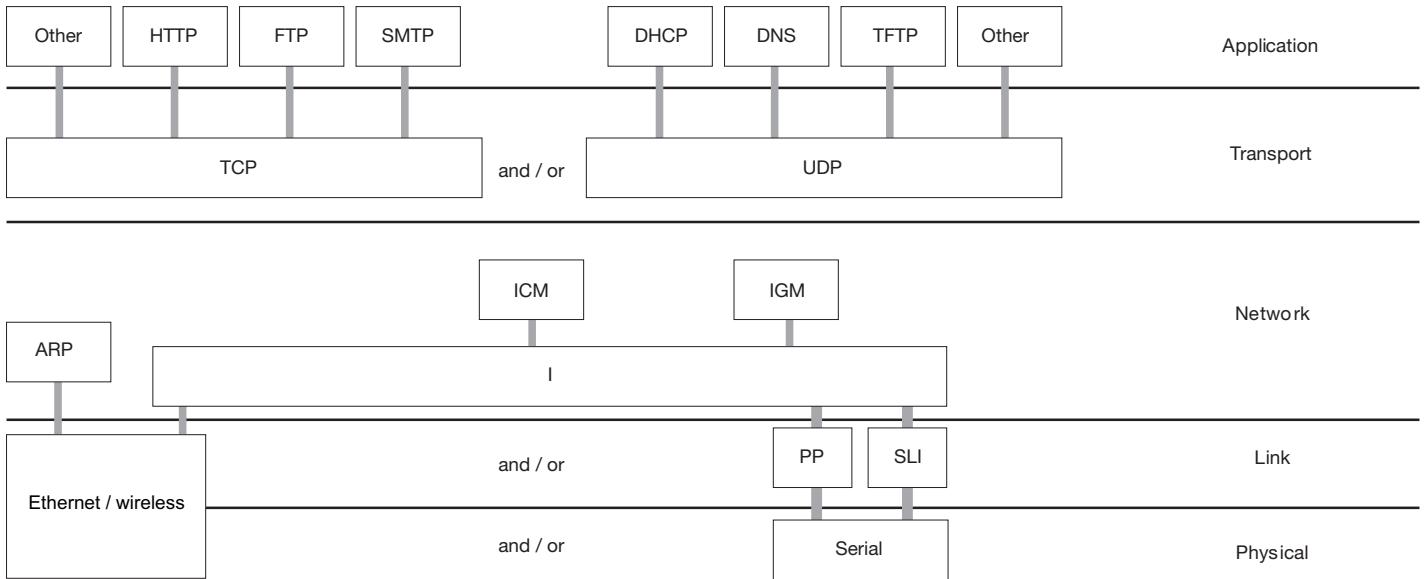

At every layer where “And/Or” is indicated, at least one of the protocols must be used. This is particularly important for embedded systems with limited resources. For example, should an application not require TCP capabilities, μC/TCP-IP can be configured to include UDP only at the Transport layer. At the Application layer, an application can use any of the Micrium applications or none. At the Link and Physical layers, there is a choice of Local Area Networking (LAN) technologies. Multiple Network Interfaces are available via the μC/TCP-IP multi-homing feature.

For pricing, delivery, and ordering information, please visit Micrium’s website at: www.micrium.com.

Micrium

For the way Engineers work

X-ON Electronics

Largest Supplier of Electrical and Electronic Components

Click to view similar products for [Processor Accessories](#) category:

Click to view products by [Micrium](#) manufacturer:

Other Similar products are found below :

[2447](#) [451651](#) [SPB204-AL-1](#) [90001265-88](#) [32316](#) [MIKROE-2147](#) [20-101-0431](#) [28148](#) [T050000](#) [28961](#) [28960](#) [Basic US PI3 Kit](#)
[82634DSARPLTVIK](#) [1557](#) [20-101-0502](#) [28109](#) [EP-CHUPCNETPLUS](#) [1019](#) [4466](#) [AD-FMC-SDCARD](#) [ATATMEL-ICE-CABLE](#)
[ATATMEL-ICE-PCBA](#) [ATAVR-MICTOR38](#) [Basic INTL PI3 Kit](#) [20-101-0495](#) [BK0006](#) [BK0007](#) [LG624](#) [DAISY CHAIN-1](#) [MIKROE-2094](#)
[MIKROE-2148](#) [MIKROE-2149](#) [130-35000](#) [28106](#) [28152](#) [30055](#) [30078](#) [32333](#) [555-28188](#) [572-28132](#) [CWH-CTP-STC-YE](#) [910-28015B](#)
[ATABOT](#) [700-00056](#) [FXX-3006-JES](#) [28114](#) [28985](#) [868](#) [1744](#) [ARX-DSP](#) [B000003](#)