

---

## QT8 Xplained Pro User's Guide

---

### Preface

---

The QT8 Xplained Pro is an extension kit that showcases Microchip's robust Water Tolerant 2D Touch Surface solution. The kit shows the water tolerance performance of capacitive touch using the **PTC's Driven Shield+** feature. The kit has 5x5 2D Touch Surface sensor and driven shield. It also has 11 LEDs to indicate touch position.

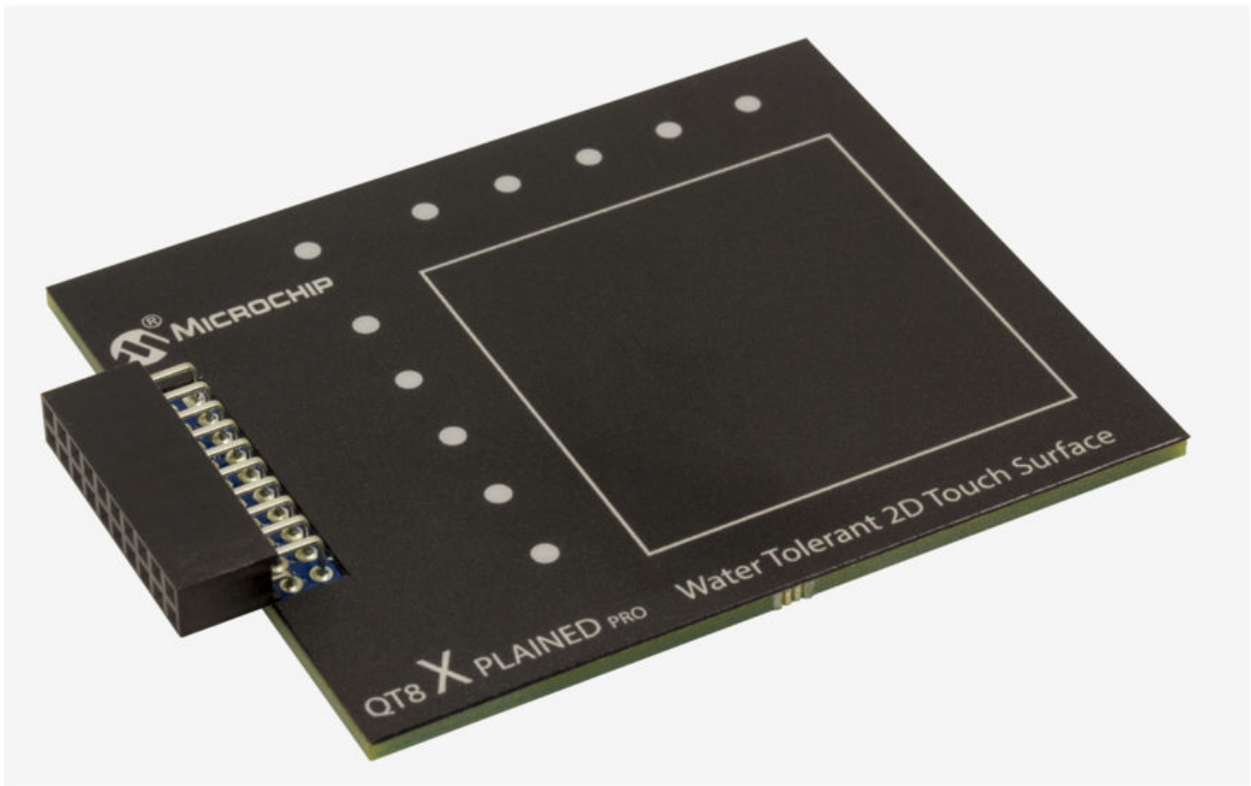

## Table of Contents

---

Preface.....	1
1. Introduction.....	3
1.1. Features and Overview.....	3
1.2. Kit Compatibility.....	3
1.3. QT8 Xplained Pro Functional Block Diagram.....	3
2. Getting Started.....	4
2.1. Quick Start.....	4
2.2. Surface Sensor Design.....	4
2.3. LEDs.....	5
2.4. Documentation and Relevant Links.....	5
3. Xplained Pro.....	7
3.1. Hardware Identification System.....	7
3.2. Xplained Pro Standard Connectors.....	7
4. Hardware Users Guide.....	9
4.1. Electrical Characteristics.....	9
4.2. Headers and Connectors.....	9
4.3. Operation Modes.....	10
4.4. Application Flow.....	13
5. Hardware Revision History and Known Issues.....	15
5.1. Identifying Product ID and Revision.....	15
5.2. Revision 3.....	15
6. Document Revision History.....	16
The Microchip Web Site.....	17
Customer Change Notification Service.....	17
Customer Support.....	17
Microchip Devices Code Protection Feature.....	17
Legal Notice.....	18
Trademarks.....	18
Quality Management System Certified by DNV.....	19
Worldwide Sales and Service.....	20

## 1. Introduction

### 1.1 Features and Overview

- Surface Sensor: 5x5 2D Surface Diamond Pattern with Dedicated Driven Shield
- LEDs: LEDs to Indicate Position and Mode
- LED Driver: MCP23017

### 1.2 Kit Compatibility

This kit is supported by Xplained Pro Microcontroller (MCU) boards that have an MCU with a built-in PTC and a matching pinout that connects all sensors of the extension.

Currently supported MCU boards are:

- SAM L10 Xplained Pro
- SAM L11 Xplained Pro
- SAM D20 Xplained Pro
- SAM D21 Xplained Pro
- SAM DA1 Xplained Pro
- SAM C21 Xplained Pro
- ATtiny3217 Xplained Pro (Refer to the [Extension Header 1 table](#) for Jumper settings.)

Other future Xplained Pro MCU board designs may also support the QT8 Xplained Pro.

### 1.3 QT8 Xplained Pro Functional Block Diagram

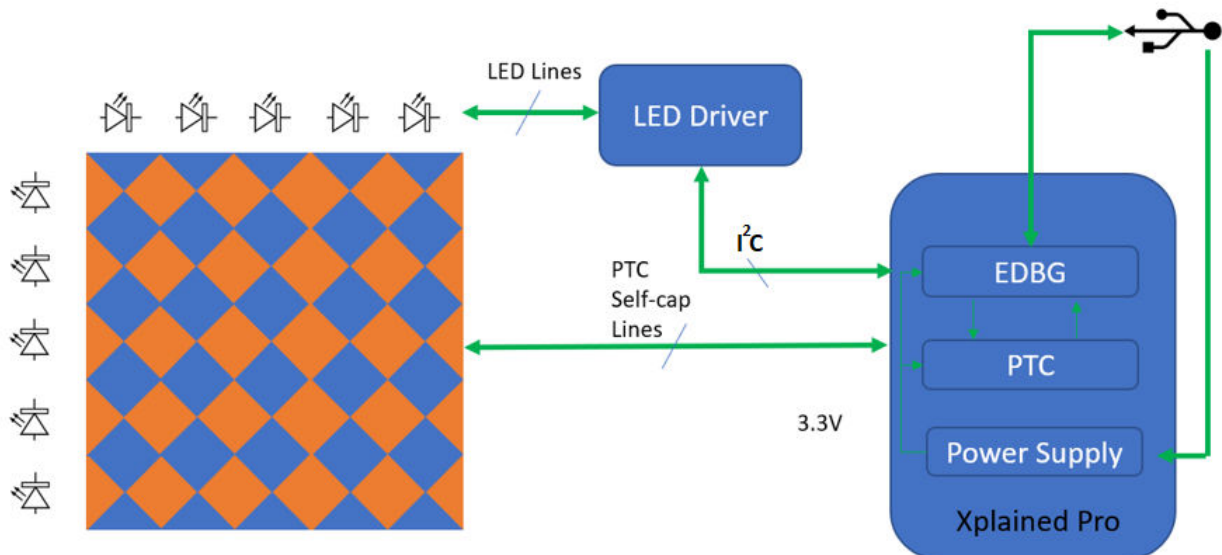

## 2. Getting Started

### 2.1 Quick Start

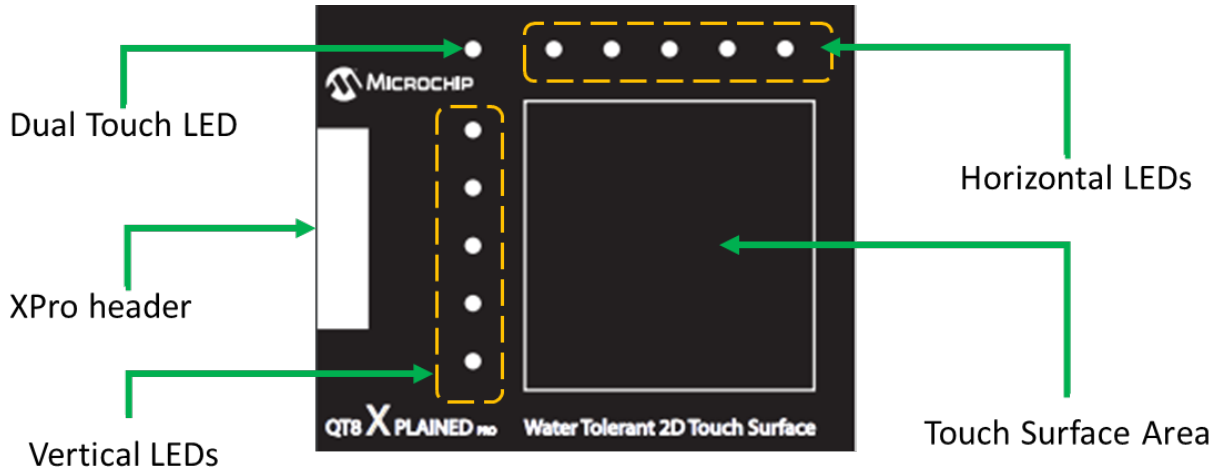

### 2.2 Surface Sensor Design

Figure 2-1. Surface Sensor

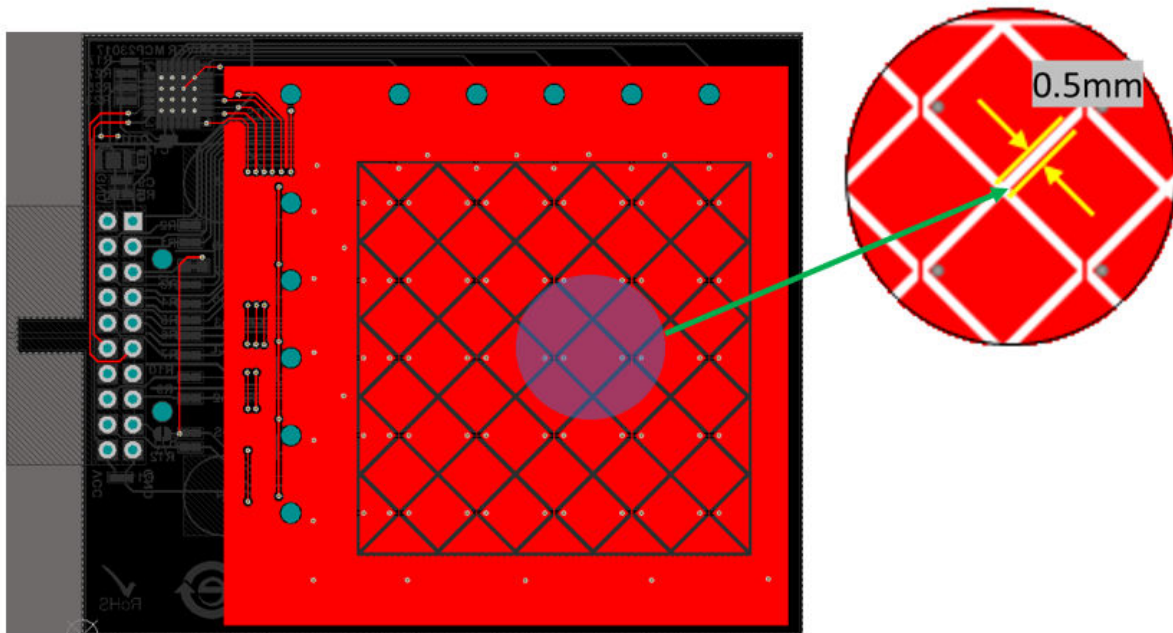
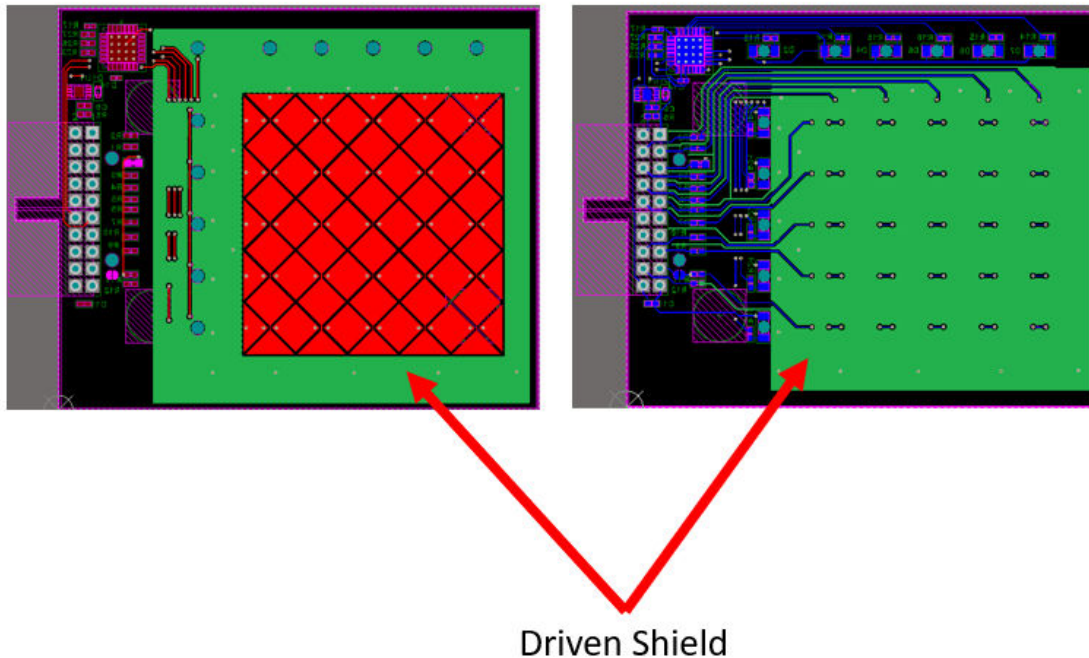

Figure 2-2. Driven Shield



## 2.3 LEDs

### Dual Touch LED

This LED glows when two fingers touch the Touch Surface Area (see [2.1 Quick Start](#)).

## 2.4 Documentation and Relevant Links

- **Xplained Products:** Xplained evaluation kits are a series of easy-to-use evaluation kits for Microchip microcontrollers and other Microchip products.
  - Xplained Nano – used for low pin count devices and provides a minimalistic solution with access to all I/O pins of the target microcontroller.
  - Xplained Mini – used for medium pin count devices and adds an Arduino Uno compatible header footprint and a prototyping area.
  - Xplained Pro – used for medium to high pin count devices that feature advanced debugging and standardized extensions for peripheral functions.



**Important:** All the above kits have on-board programmers/debuggers, which creates a set of low-cost boards for evaluation and demonstration of features and capabilities of different Microchip products.

- **Atmel® Start:** This tool will help you select and configure software components and tailor your embedded application in a usable and optimized manner

- **Atmel Studio:** Free Atmel IDE for development of C/C++ and assembler code for Atmel microcontrollers.
- **Data Visualizer:** Atmel Data Visualizer is a program used for processing and visualizing data. Data Visualizer can receive data from various sources such as the Embedded Debugger Data Gateway Interface found on Xplained Pro boards and COM ports.
- **Design Documentation:** Package containing CAD source, schematics, BOM, assembly drawings, 3D plots, layer plots, etc.
- **Hardware User's Guide:** PDF version of this user's guide.
- **QT8 Xplained Pro:** on Microchip's website.

### 3. Xplained Pro

The Xplained Pro is an evaluation platform that contains a series of microcontroller boards (evaluation kits) and extension boards. Atmel Studio is used to program and debug the microcontrollers on these boards. Atmel Studio includes an Advanced Software Framework (ASF) and Atmel START, which has drivers, demo code and Data Visualizer that supports data streaming and advanced debugging.

Xplained Pro evaluation kits can be connected to a wide range of Xplained Pro extension boards through standardized headers and connectors. Xplained Pro extension boards have identification (ID) chips to uniquely identify which boards are connected to the Xplained Pro evaluation kits.

#### 3.1 Hardware Identification System

All Xplained Pro extension boards come with an identification chip (ATSHA204A CryptoAuthentication™ chip) to uniquely identify the boards that are connected to the Xplained Pro evaluation kit. This chip contains information that identifies the extension with its name and some extra data. When an Xplained Pro extension is connected to an Xplained Pro evaluation kit, the information is read and sent to Atmel Studio. The following table shows the data fields stored in the ID chip with example content.

**Table 3-1. Xplained Pro ID Chip Content**

Data Field	Data Type	Example Content
Manufacturer	ASCII string	Microchip\0'
Product name	ASCII string	Segment QT8 Xplained Pro\0'
Product revision	ASCII string	02\0'
Product serial number	ASCII string	1774020200000010\0'
Minimum voltage [mV]	uint16_t	3000
Maximum voltage [mV]	uint16_t	3600
Maximum current [mA]	uint16_t	30

#### 3.2 Xplained Pro Standard Connectors

##### 3.2.1 Xplained Pro Standard Extension Headers

All Xplained Pro kits have many dual row, 20-pin, 100-mil extension headers. The Xplained Pro MCU boards have male headers, while the Xplained Pro extensions have female counterparts. The following table provides the pin description of all the connected pins.

**Info:** Not all pins are always connected on all extension headers.

The extension headers can be used to connect a variety of Xplained Pro extensions to Xplained Pro MCU boards or to access the pins of the target microcontroller on the Xplained Pro boards.

**Table 3-2. Xplained Pro Standard Extension Header**

Pin Number	Pin Name	Description
1	ID	Pin to communicate with the ID chip on an extension board

.....continued

Pin Number	Pin Name	Description
2	GND	Ground
3	ADC(+)	Analog-to-Digital Converter; alternatively, a pin for the positive terminal of a differential ADC
4	ADC(-)	Analog-to-Digital Converter; alternatively, a pin for the negative terminal of a differential ADC
5	GPIO1	General purpose I/O pin
6	GPIO2	General purpose I/O pin
7	PWM(+)	Pulse-Width Modulation; alternatively, a pin for the positive part of a differential PWM
8	PWM(-)	Pulse-Width Modulation; alternatively, a pin for the negative part of a differential PWM
9	IRQ/GPIO	Interrupt request pin and/or general purpose I/O pin
10	SPI_SS_B/ GPIO	Slave select pin for Serial Peripheral Interface (SPI) and/or general purpose I/O pin
11	I <sup>2</sup> C_SDA	Data pin for I <sup>2</sup> C interface. Always connected, bus type
12	I <sup>2</sup> C_SCL	Clock pin for I <sup>2</sup> C interface. Always connected, bus type
13	UART_RX	Receiver pin of target device UART
14	UART_TX	Transmitter pin of target device UART
15	SPI_SS_A	Slave select for SPI. This pin should preferably not be connected to anything else
16	SPI_MOSI	SPI master out, slave in pin. Always connected, bus type
17	SPI_MISO	SPI master in, slave out pin. Always connected, bus type
18	SPI_SCK	SPI clock pin. Always connected, bus type
19	GND	Ground pin for extension boards
20	VCC	Power pin for extension boards



## 4. Hardware Users Guide

### 4.1 Electrical Characteristics

QT8 Xplained Pro can be connected to several Xplained Pro MCU boards and manually connected to other hardware. Xplained Pro MCU board(s) that does not have 3.3V as its primary target voltage will read all ID devices on connected extensions to check if they support the target voltage before enabling it to the extension headers. The table below shows the static content written in the ID chip.

**Table 4-1. QT8 Xplained Pro ID Chip Content**

Data field	Content
Product name	QT8 Xplained Pro
Minimum operation voltage	2.7V
Maximum operation voltage	5.5V
Maximum current	45 mA

See also Hardware Identification System.

### 4.2 Headers and Connectors

#### 4.2.1 Extension Headers

The QT8 Xplained Pro implements one Xplained Pro Standard Extension Header (see section Xplained Pro Standard Extension Header) marked with EXT1 in silkscreen. This header makes it possible to connect the board to an Xplained Pro MCU board with an MCU featuring a PTC module. The pinout definition for the extension header can be seen in the table below.

**Table 4-2. QT8 Xplained Pro Extension Header 1**

Pin on EXT1	Function	Description
1	ID	Communication Line to ID Chip
2	GND	Ground
3	Y-Line-8	Channel 8: Connected to Surface Horizontal position 3
4	Y-Line-9	Channel 9: Connected to Surface Horizontal position 4
5	Y-Line-0	Channel 0: Connected to Surface Vertical position 0. <sup>(1)</sup>
6	Y-Line-7	Channel 7: Connected to Surface Horizontal position 2
7	Y-Line-6	Channel 6: Connected to Surface Horizontal position 1
8	Y-Line-5	Channel 5: Connected to Surface Horizontal position 0
9	Y-Line-4	Channel 4: Connected to Surface Vertical position 4
10	Y-Line-3	Channel 3: Connected to Surface Vertical position 3
11	I <sup>2</sup> C _SDA	LED Driver: Identify Touch Position

.....continued

Pin on EXT1	Function	Description
12	I <sup>2</sup> C _SCL	LED Driver: Identify Touch Position
13	Not Connected	
14	Not Connected	
15	Y-Line-1	Channel 1: Connected to Surface Vertical position 1
16	Y-Line-2	Channel 2: Connected to Surface Vertical position 2
17	Y-Line-0	Channel 0: Connected to Surface Vertical position 0. <sup>(2)</sup>
18	Y-Line-DR	Y-line DR: Connected to Driven Shield
19	GND	Ground
20	VCC	Target Supply Voltage

**Note:**

1. Pin 5 on EXT1 Jumper-J2 should be Open when connected to 3217 Xplained Pro.
2. Pin 17 on EXT1 Jumper-J3 should be Closed when connected to 3217 Xplained Pro.

### 4.3 Operation Modes

The kit operates in two different modes, described in the following sub-sections.

#### 4.3.1 Position Mode

In Position mode the user touch position is decoded, and based on the position the vertical and horizontal LEDs will glow. After power-up, the kit operates in this mode.



**Important:** In this kit, two-touch is supported only for gestures. No two-individual position can be decoded correctly due to self-capacitance sensor arrangement. If the user tries to do two-touch, then the decoding stops and the two-touch LED glows.

#### 4.3.2 Gesture Mode

In Gesture mode, depending on the gesture, the LEDs glow to indicate the gesture. The tap is indicated by a blink according to the number of taps and swipes that are indicated by LED chasing. The following table provides information on how LEDs glow when a gesture is performed.

Gesture	LED Chasing Direction
Tap	No chasing. All vertical and horizontal LEDs blink according to number of taps.

.....continued	
Gesture	LED Chasing Direction
Left Swipe	<p>The diagram shows a 6x6 grid of red dots. A green arrow above the top row points to the left, indicating the LED chasing direction.</p>
Right Swipe	<p>The diagram shows a 6x6 grid of red dots. A green arrow above the top row points to the right, indicating the LED chasing direction.</p>
Up Swipe	<p>The diagram shows a 6x6 grid of red dots. A green arrow to the left of the first column points upwards, indicating the LED chasing direction.</p>

.....continued	
Gesture	LED Chasing Direction
Down Swipe	
Clockwise Wheel Gesture	
Counter-Clockwise Wheel Gesture	

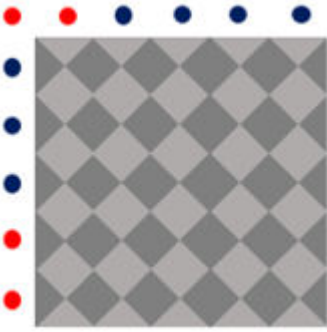
.....continued	
Gesture	LED Chasing Direction
Pinch-Zoom	<p><b>Zoom:</b> The horizontal and vertical LEDs start to glow from one end.</p> <p><b>Pinch:</b> The horizontal and vertical LEDs start to diminish from one end.</p>
	

### 4.3.3 Connecting to GUI

Due to code memory limitations, the application can either use the LEDs to show touch performance or use the data streamer to stream data to the 2D Touch Surface Utility. By default, the project is compiled to display data in the LEDs (Data Streamer is disabled). To connect to the GUI, modify the following code in *touch.h* file and program the *.hex* file.

#### Example 4-1. Disable LED

```
#define ENABLE_LED 0u
```

#### Example 4-2. Endable Data Streamer

```
#define KRONOCOMM_UART 1u
#define KRONOCOMM_ENABLE 1u
#define KRONO_GESTURE_ENABLE 1u
```

**Note:**

1. Refer to the guide to connect the kit to the data streamer.
2. Comport Settings: Baud rate is 38400, Parity none, Stop bit 1 and flow control none.

## 4.4 Application Flow

The following diagram shows the application flow. Touch measurement are performed at regular intervals. At the end of each measurement, the surface and gesture data are taken from the library. Depending on the position or gesture information, the LEDs are updated.

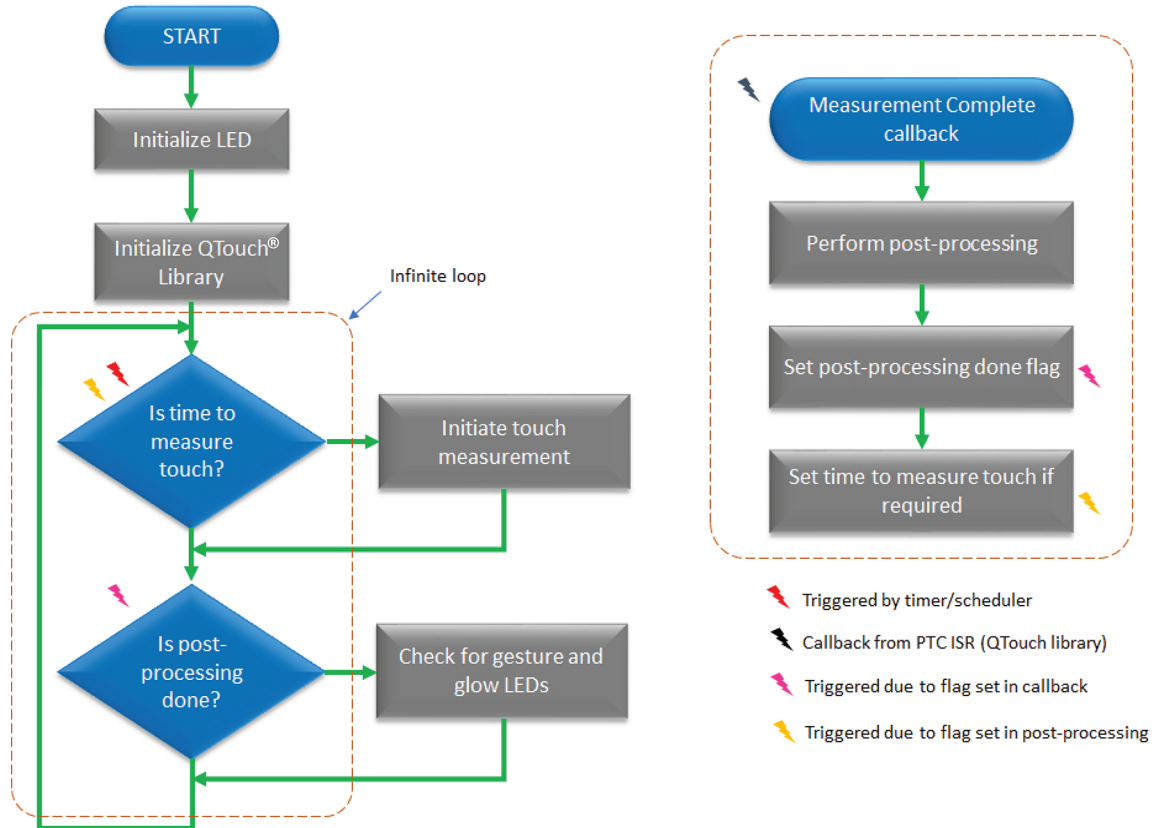

## 5. Hardware Revision History and Known Issues

### 5.1 Identifying Product ID and Revision

There are two ways to find the revision and product identifier of the Xplained Pro boards: either through Atmel Studio or by looking at the sticker on the bottom side of the PCB.

When an Xplained Pro MCU board is connected to a computer with Atmel Studio running, an information window with the serial number is shown. The first six digits of the serial number contain the product identifier and revision. Information about connected Xplained Pro extension boards is also shown in the window.

The same information can be found on the sticker on the bottom side of the PCB. Most kits have stickers that have the identifier and revision printed in plain text as A09-nnnn/rr, where nnnn is the identifier and rr is the revision. Boards with limited space have a sticker with only a data matrix code, which contains a serial number string.

The serial number string has the following format:

"nnnnrrssssssss"

n = product identifier

r = revision

s = serial number

The product identifier for the QT8 Xplained Pro is A09-3197.

### 5.2 Revision 3

Revision 3 of QT8 Xplained Pro (A09-3195/03) is the initial released version. There are no known issues.

**6. Document Revision History**

Doc. rev.	Date	Comment
A	10/2018	Initial document release



## The Microchip Web Site

---

Microchip provides online support via our web site at <http://www.microchip.com/>. This web site is used as a means to make files and information easily available to customers. Accessible by using your favorite Internet browser, the web site contains the following information:

- **Product Support** – Data sheets and errata, application notes and sample programs, design resources, user's guides and hardware support documents, latest software releases and archived software
- **General Technical Support** – Frequently Asked Questions (FAQ), technical support requests, online discussion groups, Microchip consultant program member listing
- **Business of Microchip** – Product selector and ordering guides, latest Microchip press releases, listing of seminars and events, listings of Microchip sales offices, distributors and factory representatives

## Customer Change Notification Service

---

Microchip's customer notification service helps keep customers current on Microchip products. Subscribers will receive e-mail notification whenever there are changes, updates, revisions or errata related to a specified product family or development tool of interest.

To register, access the Microchip web site at <http://www.microchip.com/>. Under "Support", click on "Customer Change Notification" and follow the registration instructions.

## Customer Support

---

Users of Microchip products can receive assistance through several channels:

- Distributor or Representative
- Local Sales Office
- Field Application Engineer (FAE)
- Technical Support

Customers should contact their distributor, representative or Field Application Engineer (FAE) for support. Local sales offices are also available to help customers. A listing of sales offices and locations is included in the back of this document.

Technical support is available through the web site at: <http://www.microchip.com/support>

## Microchip Devices Code Protection Feature

---

Note the following details of the code protection feature on Microchip devices:

- Microchip products meet the specification contained in their particular Microchip Data Sheet.
- Microchip believes that its family of products is one of the most secure families of its kind on the market today, when used in the intended manner and under normal conditions.
- There are dishonest and possibly illegal methods used to breach the code protection feature. All of these methods, to our knowledge, require using the Microchip products in a manner outside the operating specifications contained in Microchip's Data Sheets. Most likely, the person doing so is engaged in theft of intellectual property.
- Microchip is willing to work with the customer who is concerned about the integrity of their code.

- Neither Microchip nor any other semiconductor manufacturer can guarantee the security of their code. Code protection does not mean that we are guaranteeing the product as “unbreakable.”

Code protection is constantly evolving. We at Microchip are committed to continuously improving the code protection features of our products. Attempts to break Microchip’s code protection feature may be a violation of the Digital Millennium Copyright Act. If such acts allow unauthorized access to your software or other copyrighted work, you may have a right to sue for relief under that Act.

## Legal Notice

---

Information contained in this publication regarding device applications and the like is provided only for your convenience and may be superseded by updates. It is your responsibility to ensure that your application meets with your specifications. MICROCHIP MAKES NO REPRESENTATIONS OR WARRANTIES OF ANY KIND WHETHER EXPRESS OR IMPLIED, WRITTEN OR ORAL, STATUTORY OR OTHERWISE, RELATED TO THE INFORMATION, INCLUDING BUT NOT LIMITED TO ITS CONDITION, QUALITY, PERFORMANCE, MERCHANTABILITY OR FITNESS FOR PURPOSE. Microchip disclaims all liability arising from this information and its use. Use of Microchip devices in life support and/or safety applications is entirely at the buyer’s risk, and the buyer agrees to defend, indemnify and hold harmless Microchip from any and all damages, claims, suits, or expenses resulting from such use. No licenses are conveyed, implicitly or otherwise, under any Microchip intellectual property rights unless otherwise stated.

## Trademarks

---

The Microchip name and logo, the Microchip logo, AnyRate, AVR, AVR logo, AVR Freaks, BitCloud, chipKIT, chipKIT logo, CryptoMemory, CryptoRF, dsPIC, FlashFlex, flexPWR, Heldo, JukeBlox, KeeLoq, Klear, LANCheck, LINK MD, maXStylus, maXTouch, MediaLB, megaAVR, MOST, MOST logo, MPLAB, OptoLyzer, PIC, picoPower, PICSTART, PIC32 logo, Prochip Designer, QTouch, SAM-BA, SpyNIC, SST, SST Logo, SuperFlash, tinyAVR, UNI/O, and XMEGA are registered trademarks of Microchip Technology Incorporated in the U.S.A. and other countries.

ClockWorks, The Embedded Control Solutions Company, EtherSynch, Hyper Speed Control, HyperLight Load, IntelliMOS, mTouch, Precision Edge, and Quiet-Wire are registered trademarks of Microchip Technology Incorporated in the U.S.A.

Adjacent Key Suppression, AKS, Analog-for-the-Digital Age, Any Capacitor, AnyIn, AnyOut, BodyCom, CodeGuard, CryptoAuthentication, CryptoAutomotive, CryptoCompanion, CryptoController, dsPICDEM, dsPICDEM.net, Dynamic Average Matching, DAM, ECAN, EtherGREEN, In-Circuit Serial Programming, ICSP, INICnet, Inter-Chip Connectivity, JitterBlocker, KlearNet, KlearNet logo, memBrain, Mindi, MiWi, motorBench, MPASM, MPF, MPLAB Certified logo, MPLIB, MPLINK, MultiTRAK, NetDetach, Omniscient Code Generation, PICDEM, PICDEM.net, PICKit, PICtail, PowerSmart, PureSilicon, QMatrix, REAL ICE, Ripple Blocker, SAM-ICE, Serial Quad I/O, SMART-I.S., SQI, SuperSwitcher, SuperSwitcher II, Total Endurance, TSHARC, USBCheck, VariSense, ViewSpan, WiperLock, Wireless DNA, and ZENA are trademarks of Microchip Technology Incorporated in the U.S.A. and other countries.

SQTP is a service mark of Microchip Technology Incorporated in the U.S.A.

Silicon Storage Technology is a registered trademark of Microchip Technology Inc. in other countries.

GestIC is a registered trademark of Microchip Technology Germany II GmbH & Co. KG, a subsidiary of Microchip Technology Inc., in other countries.

All other trademarks mentioned herein are property of their respective companies.

© 2018, Microchip Technology Incorporated, Printed in the U.S.A., All Rights Reserved.

ISBN: 978-1-5224-3573-0

## Quality Management System Certified by DNV

---

### ISO/TS 16949

Microchip received ISO/TS-16949:2009 certification for its worldwide headquarters, design and wafer fabrication facilities in Chandler and Tempe, Arizona; Gresham, Oregon and design centers in California and India. The Company's quality system processes and procedures are for its PIC<sup>®</sup> MCUs and dsPIC<sup>®</sup> DSCs, KEELOQ<sup>®</sup> code hopping devices, Serial EEPROMs, microperipherals, nonvolatile memory and analog products. In addition, Microchip's quality system for the design and manufacture of development systems is ISO 9001:2000 certified.

## Worldwide Sales and Service

AMERICAS	ASIA/PACIFIC	ASIA/PACIFIC	EUROPE
<p><b>Corporate Office</b> 2355 West Chandler Blvd. Chandler, AZ 85224-6199 Tel: 480-792-7200 Fax: 480-792-7277 Technical Support: <a href="http://www.microchip.com/support">http://www.microchip.com/support</a> Web Address: <a href="http://www.microchip.com">www.microchip.com</a></p> <p><b>Atlanta</b> Duluth, GA Tel: 678-957-9614 Fax: 678-957-1455</p> <p><b>Austin, TX</b> Tel: 512-257-3370</p> <p><b>Boston</b> Westborough, MA Tel: 774-760-0087 Fax: 774-760-0088</p> <p><b>Chicago</b> Itasca, IL Tel: 630-285-0071 Fax: 630-285-0075</p> <p><b>Dallas</b> Addison, TX Tel: 972-818-7423 Fax: 972-818-2924</p> <p><b>Detroit</b> Novi, MI Tel: 248-848-4000</p> <p><b>Houston, TX</b> Tel: 281-894-5983</p> <p><b>Indianapolis</b> Noblesville, IN Tel: 317-773-8323 Fax: 317-773-5453 Tel: 317-536-2380</p> <p><b>Los Angeles</b> Mission Viejo, CA Tel: 949-462-9523 Fax: 949-462-9608 Tel: 951-273-7800</p> <p><b>Raleigh, NC</b> Tel: 919-844-7510</p> <p><b>New York, NY</b> Tel: 631-435-6000</p> <p><b>San Jose, CA</b> Tel: 408-735-9110 Tel: 408-436-4270</p> <p><b>Canada - Toronto</b> Tel: 905-695-1980 Fax: 905-695-2078</p>	<p><b>Australia - Sydney</b> Tel: 61-2-9868-6733</p> <p><b>China - Beijing</b> Tel: 86-10-8569-7000</p> <p><b>China - Chengdu</b> Tel: 86-28-8665-5511</p> <p><b>China - Chongqing</b> Tel: 86-23-8980-9588</p> <p><b>China - Dongguan</b> Tel: 86-769-8702-9880</p> <p><b>China - Guangzhou</b> Tel: 86-20-8755-8029</p> <p><b>China - Hangzhou</b> Tel: 86-571-8792-8115</p> <p><b>China - Hong Kong SAR</b> Tel: 852-2943-5100</p> <p><b>China - Nanjing</b> Tel: 86-25-8473-2460</p> <p><b>China - Qingdao</b> Tel: 86-532-8502-7355</p> <p><b>China - Shanghai</b> Tel: 86-21-3326-8000</p> <p><b>China - Shenyang</b> Tel: 86-24-2334-2829</p> <p><b>China - Shenzhen</b> Tel: 86-755-8864-2200</p> <p><b>China - Suzhou</b> Tel: 86-186-6233-1526</p> <p><b>China - Wuhan</b> Tel: 86-27-5980-5300</p> <p><b>China - Xian</b> Tel: 86-29-8833-7252</p> <p><b>China - Xiamen</b> Tel: 86-592-2388138</p> <p><b>China - Zhuhai</b> Tel: 86-756-3210040</p>	<p><b>India - Bangalore</b> Tel: 91-80-3090-4444</p> <p><b>India - New Delhi</b> Tel: 91-11-4160-8631</p> <p><b>India - Pune</b> Tel: 91-20-4121-0141</p> <p><b>Japan - Osaka</b> Tel: 81-6-6152-7160</p> <p><b>Japan - Tokyo</b> Tel: 81-3-6880-3770</p> <p><b>Korea - Daegu</b> Tel: 82-53-744-4301</p> <p><b>Korea - Seoul</b> Tel: 82-2-554-7200</p> <p><b>Malaysia - Kuala Lumpur</b> Tel: 60-3-7651-7906</p> <p><b>Malaysia - Penang</b> Tel: 60-4-227-8870</p> <p><b>Philippines - Manila</b> Tel: 63-2-634-9065</p> <p><b>Singapore</b> Tel: 65-6334-8870</p> <p><b>Taiwan - Hsin Chu</b> Tel: 886-3-577-8366</p> <p><b>Taiwan - Kaohsiung</b> Tel: 886-7-213-7830</p> <p><b>Taiwan - Taipei</b> Tel: 886-2-2508-8600</p> <p><b>Thailand - Bangkok</b> Tel: 66-2-694-1351</p> <p><b>Vietnam - Ho Chi Minh</b> Tel: 84-28-5448-2100</p>	<p><b>Austria - Wels</b> Tel: 43-7242-2244-39 Fax: 43-7242-2244-393</p> <p><b>Denmark - Copenhagen</b> Tel: 45-4450-2828 Fax: 45-4485-2829</p> <p><b>Finland - Espoo</b> Tel: 358-9-4520-820</p> <p><b>France - Paris</b> Tel: 33-1-69-53-63-20 Fax: 33-1-69-30-90-79</p> <p><b>Germany - Garching</b> Tel: 49-8931-9700</p> <p><b>Germany - Haan</b> Tel: 49-2129-3766400</p> <p><b>Germany - Heilbronn</b> Tel: 49-7131-67-3636</p> <p><b>Germany - Karlsruhe</b> Tel: 49-721-625370</p> <p><b>Germany - Munich</b> Tel: 49-89-627-144-0 Fax: 49-89-627-144-44</p> <p><b>Germany - Rosenheim</b> Tel: 49-8031-354-560</p> <p><b>Israel - Ra'anana</b> Tel: 972-9-744-7705</p> <p><b>Italy - Milan</b> Tel: 39-0331-742611 Fax: 39-0331-466781</p> <p><b>Italy - Padova</b> Tel: 39-049-7625286</p> <p><b>Netherlands - Drunen</b> Tel: 31-416-690399 Fax: 31-416-690340</p> <p><b>Norway - Trondheim</b> Tel: 47-72884388</p> <p><b>Poland - Warsaw</b> Tel: 48-22-3325737</p> <p><b>Romania - Bucharest</b> Tel: 40-21-407-87-50</p> <p><b>Spain - Madrid</b> Tel: 34-91-708-08-90 Fax: 34-91-708-08-91</p> <p><b>Sweden - Gothenberg</b> Tel: 46-31-704-60-40</p> <p><b>Sweden - Stockholm</b> Tel: 46-8-5090-4654</p> <p><b>UK - Wokingham</b> Tel: 44-118-921-5800 Fax: 44-118-921-5820</p>

## X-ON Electronics

Largest Supplier of Electrical and Electronic Components

*Click to view similar products for [WiFi Development Tools - 802.11 category](#):*

*Click to view products by [Microchip manufacturer](#):*

Other Similar products are found below :

[YSAEWIFI-1](#) [SKY65981-11EK1](#) [QPF7221PCK-01](#) [SIMSA915C-Cloud-DKL](#) [SIMSA433C-Cloud-DKL](#) [ISM43903-R48-EVB-E](#)  
[QPF4206BEVB01](#) [RN-G2SDK](#) [SKY85734-11EK1](#) [SKY85735-11EK1](#) [ENW49D01AZKF](#) [ESP-LAUNCHER](#) [MIKROE-2336](#)  
[EVAL\\_PAN1760EMK](#) [3210](#) [EVAL\\_PAN1026EMK](#) [ATWINC1500-XPRO](#) [2471](#) [DM990001](#) [WRL-13711](#) [2999](#) [ATWILC3000-SHLD](#)  
[DFR0321](#) [TEL0118](#) [3213](#) [DFR0489](#) [SLWSTK-COEXBP](#) [WRL-13804](#) [DEV-13907](#) [UP-3GHAT-A20-0001](#) [3405](#) [TEL0078](#) [2680](#) [2702](#)  
[2821](#) [3044](#) [3606](#) [3653](#) [3654](#) [4000](#) [4172](#) [4178](#) [4201](#) [4264](#) [4285](#) [CS-ANAVI-25](#) [CS-ANAVI-26](#) [CS-ANAVI-23](#) [CS-ANAVI-24](#) [CS-ANAVI-28](#)