



**MICROCHIP**

---

**Processor Extension Pak (PEP)  
and Debug Header  
Specification**

---

---

**Note the following details of the code protection feature on Microchip devices:**

- Microchip products meet the specification contained in their particular Microchip Data Sheet.
- Microchip believes that its family of products is one of the most secure families of its kind on the market today, when used in the intended manner and under normal conditions.
- There are dishonest and possibly illegal methods used to breach the code protection feature. All of these methods, to our knowledge, require using the Microchip products in a manner outside the operating specifications contained in Microchip's Data Sheets. Most likely, the person doing so is engaged in theft of intellectual property.
- Microchip is willing to work with the customer who is concerned about the integrity of their code.
- Neither Microchip nor any other semiconductor manufacturer can guarantee the security of their code. Code protection does not mean that we are guaranteeing the product as "unbreakable."

Code protection is constantly evolving. We at Microchip are committed to continuously improving the code protection features of our products. Attempts to break Microchip's code protection feature may be a violation of the Digital Millennium Copyright Act. If such acts allow unauthorized access to your software or other copyrighted work, you may have a right to sue for relief under that Act.

---

Information contained in this publication regarding device applications and the like is provided only for your convenience and may be superseded by updates. It is your responsibility to ensure that your application meets with your specifications. MICROCHIP MAKES NO REPRESENTATIONS OR WARRANTIES OF ANY KIND WHETHER EXPRESS OR IMPLIED, WRITTEN OR ORAL, STATUTORY OR OTHERWISE, RELATED TO THE INFORMATION, INCLUDING BUT NOT LIMITED TO ITS CONDITION, QUALITY, PERFORMANCE, MERCHANTABILITY OR FITNESS FOR PURPOSE. Microchip disclaims all liability arising from this information and its use. Use of Microchip devices in life support and/or safety applications is entirely at the buyer's risk, and the buyer agrees to defend, indemnify and hold harmless Microchip from any and all damages, claims, suits, or expenses resulting from such use. No licenses are conveyed, implicitly or otherwise, under any Microchip intellectual property rights unless otherwise stated.

**Trademarks**

The Microchip name and logo, the Microchip logo, dsPIC, FlashFlex, flexPWR, JukeBlox, KEELOQ, KEELOQ logo, Klear, LANCheck, MediaLB, MOST, MOST logo, MPLAB, OptoLyzer, PIC, PICSTART, PIC<sup>32</sup> logo, RightTouch, SpyNIC, SST, SST Logo, SuperFlash and UNI/O are registered trademarks of Microchip Technology Incorporated in the U.S.A. and other countries.

The Embedded Control Solutions Company and mTouch are registered trademarks of Microchip Technology Incorporated in the U.S.A.

Analog-for-the-Digital Age, BodyCom, chipKIT, chipKIT logo, CodeGuard, dsPICDEM, dsPICDEM.net, ECAN, In-Circuit Serial Programming, ICSP, Inter-Chip Connectivity, KlearNet, KlearNet logo, MiWi, motorBench, MPASM, MPF, MPLAB Certified logo, MPLIB, MPLINK, MultiTRAK, NetDetach, Omniscient Code Generation, PICDEM, PICDEM.net, PICkit, PICtail, RightTouch logo, REAL ICE, SQI, Serial Quad I/O, Total Endurance, TSHARC, USBCheck, VariSense, ViewSpan, WiperLock, Wireless DNA, and ZENA are trademarks of Microchip Technology Incorporated in the U.S.A. and other countries.

SQTP is a service mark of Microchip Technology Incorporated in the U.S.A.

Silicon Storage Technology is a registered trademark of Microchip Technology Inc. in other countries.

GestIC is a registered trademark of Microchip Technology Germany II GmbH & Co. KG, a subsidiary of Microchip Technology Inc., in other countries.

All other trademarks mentioned herein are property of their respective companies.

© 2006-2015, Microchip Technology Incorporated, Printed in the U.S.A., All Rights Reserved.

ISBN: 978-1-63277-994-6

**QUALITY MANAGEMENT SYSTEM  
CERTIFIED BY DNV  
= ISO/TS 16949 =**

*Microchip received ISO/TS-16949:2009 certification for its worldwide headquarters, design and wafer fabrication facilities in Chandler and Tempe, Arizona; Gresham, Oregon and design centers in California and India. The Company's quality system processes and procedures are for its PIC<sup>®</sup> MCUs and dsPIC<sup>®</sup> DSCs, KEELOQ<sup>®</sup> code hopping devices, Serial EEPROMs, microperipherals, nonvolatile memory and analog products. In addition, Microchip's quality system for the design and manufacture of development systems is ISO 9001:2000 certified.*

**Table of Contents**

**Chapter 1. PEP and Debug Header Overview**

1.1 What is a Processor Extension Pak (PEP)? .....	5
1.2 What is a Debug Header? .....	5
1.3 Why Do I Need a Header to Debug? .....	6
1.4 Debug Details .....	7
1.5 Compare Debug Header and Device Features .....	9
1.6 Support Information .....	10
1.7 Debug Header Hardware Setup .....	11
1.8 Debug Header Setup for MPLAB X IDE .....	13
1.9 Additional Information .....	14

**Chapter 2. Required Debug Headers**

Introduction.....	15
AC162050, AC162058 .....	16
AC162052, AC162055, AC162056, AC162057 .....	18
AC162053, AC162054 .....	20
AC162059, AC162070, AC162096 .....	22
AC162060 .....	24
AC162061 .....	26
AC162066 .....	28
AC162083 .....	30
AC244023, AC244024 .....	32
AC244028 .....	34
AC244045 .....	36
AC244051, AC244052, AC244061 .....	38
AC244062 .....	40

**Chapter 3. Optional Debug Headers**

Introduction.....	43
AC162062, AC162079, AC162087, AC162091 .....	48
AC162064 .....	50
AC162065, AC244022 .....	52
AC162067, AC162074 .....	55
AC162078 .....	58
AC162088, AC162094 .....	61

# PIC18FXXXX

---

AC244026, AC244027 .....	64
AC244033, AC244034 .....	67
AC244035, AC244036 .....	69
AC244043, AC244044 .....	71
AC244046, AC244047 .....	73
AC244048 .....	75
AC244049, AC244050 .....	77
AC244053, AC244054 .....	79
AC244060 .....	81
<b>Appendix A. Debug Header Target Footprints</b>	
A.1 Introduction .....	83
A.2 DIP Device Footprints .....	83
A.3 TQFP/PLCC Device Footprints .....	83
<b>Appendix B. Debug Header Connections</b>	
B.1 Introduction .....	87
B.2 6-Pin Modular Connector .....	87
B.3 8-Pin SIL Connector .....	88
B.4 6-Pin SIL Connector .....	89
B.5 SIL Optional Connection .....	90
B.6 Modular-to-SIL Adapter .....	90
B.7 Ordering Information .....	91
<b>Appendix C: Revision History</b> .....	<b>93</b>
<b>Index</b> .....	<b>95</b>
<b>Worldwide Sales and Service</b> .....	<b>98</b>

---

---

**Chapter 1. PEP and Debug Header Overview**

---

---

**NOTICE TO CUSTOMERS**

All documentation becomes dated, and this manual is no exception. Microchip tools and documentation are constantly evolving to meet customer needs, so some actual dialogs and/or tool descriptions may differ from those in this document. Please refer to our web site ([www.microchip.com](http://www.microchip.com)) to obtain the latest documentation available.

Documents are identified with a “DS” number. This number is located on the bottom of each page, in front of the page number. The numbering convention for the DS number is “DSXXXXA”, where “XXXX” is the document number and “A” is the revision level of the document.

For the most up-to-date information on development tools, see the MPLAB X IDE online Help (Help menu).

This chapter contains the following:

- [What is a Processor Extension Pak \(PEP\)?](#)
- [What is a Debug Header?](#)
- [Why Do I Need a Header to Debug?](#)
- [Debug Details](#)
- [Compare Debug Header and Device Features](#)
- [Support Information](#)
- [Debug Header Hardware Setup](#)
- [Debug Header Setup for MPLAB X IDE](#)
- [Additional Information](#)

**1.1 WHAT IS A PROCESSOR EXTENSION PAK (PEP)?**

A Processor Extension Pak contains a debug header, adapter board, and stand-offs. A PEP is what you purchase when you want a debug header.

**1.2 WHAT IS A DEBUG HEADER?**

A debug header is a circuit board that allows an emulator or debugger to debug code for a specific device. A special version of the device (-ICE/-ICD) with on-board debug circuitry is located on the header. Connectors on the side of the header allow it to connect directly or through an adapter to the debug tool. Connectors on the bottom of the header allow it to connect directly or through a transition socket to a target board.

# PEP and Debug Header Specification

## 1.3 WHY DO I NEED A HEADER TO DEBUG?

Some PIC® microcontrollers (MCUs), particularly low-pin-count devices (with 20 pins or less), generally must use a header for debugging. This is done to free up I/O lines for your application and to make production parts more affordable. Optional headers are also available for high-pin-count devices (with 64 pins or higher).

Debugging requires a two-line connection (plus VDD, VSS and VPP) to communicate with the device. In a high-pin-count device, losing a few I/O lines is generally not a problem for most designs. But in a low-pin-count device, it can be a critical problem. Imagine having to do an 8-pin design where there are only 5 I/Os, having used up 2 I/Os just for debugging!

Headers are also used to save you money. In high-pin-count devices, adding debugging to the silicon can generally be done at little or no cost since the silicon is already fairly large. However, low-pin-count devices are low cost specifically because they use very little silicon. So, adding debugging circuitry on-board these parts would add significant cost since it would raise the amount of silicon used by a considerable percentage. The header places the cost for debugging up front and frees your production parts from the extra cost of an unused debug module.

Microchip also makes optional debug modules, usually for high-pin-count devices. The module is optional because you can still do basic debugging without a header, but if you use one, you get back I/O lines, and may also gain additional debugging features. Only certain devices can use an optional header, so see [Chapter 3. “Optional Debug Headers”](#).

Microchip lists what header must be ordered to work with your device, if one is required. Simply consult [Chapter 2. “Required Debug Headers”](#).

Note that in all cases, devices can be programmed “in circuit” (called ICSP™) with very few exceptions. Even devices without an internal debug feature can still be programmed by connecting the programming/debugging tool to the in-circuit programming lines. These devices simply cannot perform debugging without a header.

**FIGURE 1-1: PRODUCTION DEVICE VS. HEADER DEVICE**

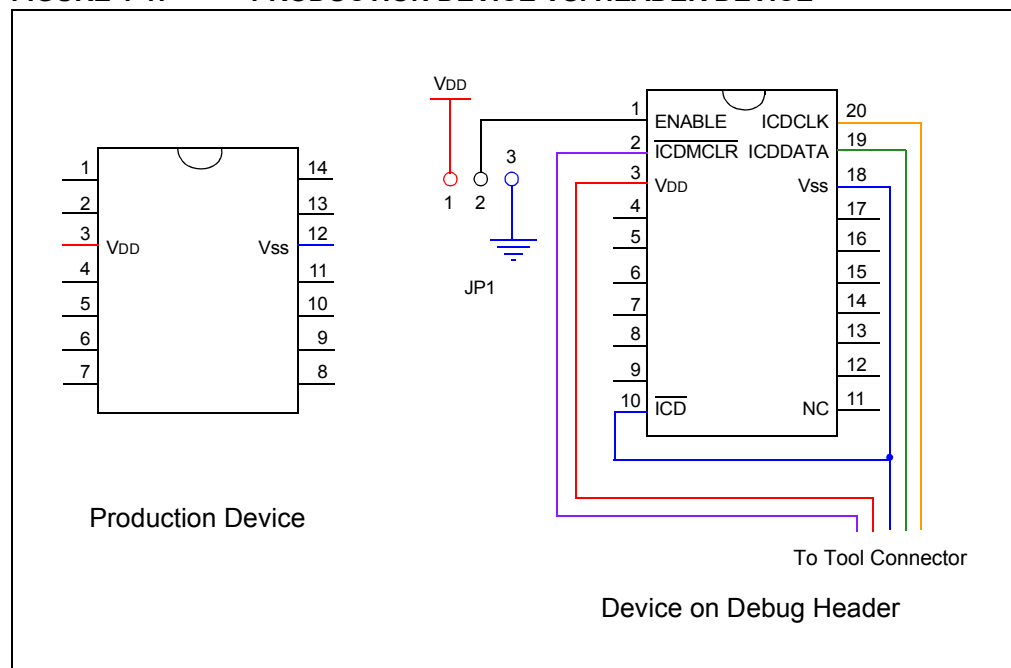

# PEP and Debug Header Overview

## 1.4 DEBUG DETAILS

Next generation in-circuit emulators (such as the MPLAB® REAL ICE™ in-circuit emulator) and in-circuit debuggers work with devices that have on-chip debug circuitry. Sometimes the actual production device will have this circuitry and sometimes a special version of this device is required or available for code debugging. This special version of the chip, with the suffix -ICE or -ICD, is mounted on a debug header (Figure 1-2).

**Note:** -ICE/-ICD devices are only used on the debug header; they are not sold separately.

**FIGURE 1-2: DEBUG OPTIONS**

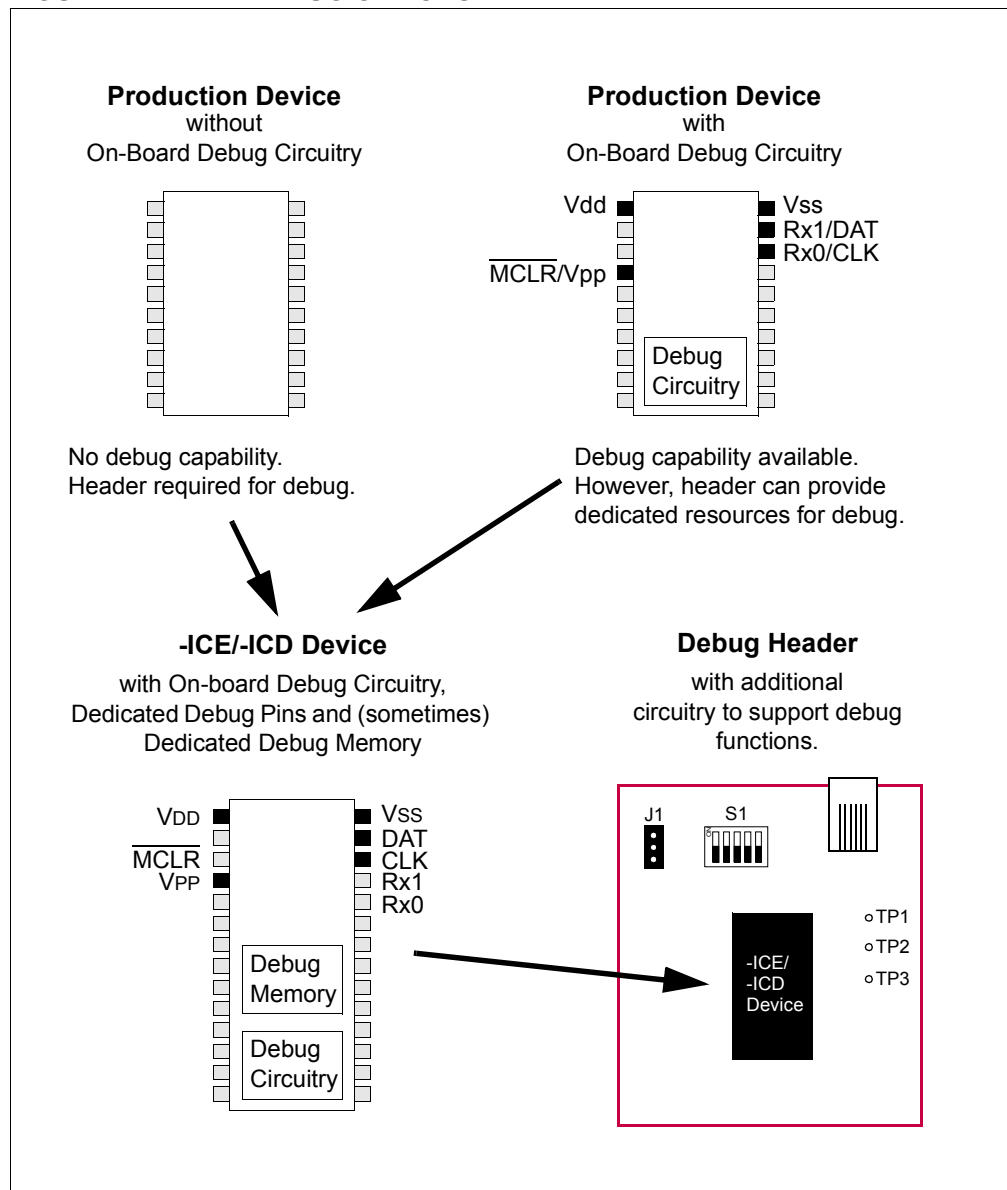

# PEP and Debug Header Specification

---

To determine which device resources must be dedicated to debugging for either a device with on-board debug capability or the special -ICE/-ICD device, see the “Resources used by ...” section of the in-circuit emulator or in-circuit debugger online Help file.

Then, depending on the debug tool, different features of the special -ICE/-ICD device may be available. A summary is provided below. To determine actual features, see the debug header documentation for a specific device.

**TABLE 1-1: DEVICE FEATURES SUMMARY**

<b>Debug Tool</b>	<b>-ICE</b>	<b>-ICD</b>
In-Circuit Emulators	Basic Emulator Functions	Basic Debug Functions
In-Circuit Debuggers	Basic Debug Functions	



## 1.5 COMPARE DEBUG HEADER AND DEVICE FEATURES

For some devices that have on-board debug capability, the optional header provides more debug features than the device itself. To determine if your device and optional header differ in their debug features, go to the Development Tool Selector (DTS) to look for your device:

1. In a web browser, go to : <http://www.microchip.com/dtsapp/>
2. Select your device from the "Select Product" list. Or, type the name of your device into the "Search" box and click **Search**. The name will appear at the top of the "Select Product" list, where you can select it.
3. Click on the tab "Emulators & Debuggers" to see debug features.

FIGURE 1-3: DTS DEVICE INFORMATION

**MICROCHIP**

Development Tool Selector - PIC16F1939

Search

**Select Product**

- PIC16F1939
- PIC16F1946
- PIC16F1947
- PIC16F505
- PIC16F506
- PIC16F526
- PIC16F527
- PIC16F54
- PIC16F57
- PIC16F570
- PIC16F59
- PIC16F610
- PIC16F616
- PIC16F627
- PIC16F627A
- PIC16F628
- PIC16F628A
- PIC16F630
- PIC16F631
- PIC16F636
- PIC16F639
- PIC16F648A
- PIC16F676
- PIC16F677
- PIC16F684
- PIC16F685
- PIC16F687
- PIC16F688
- PIC16F689
- PIC16F690
- PIC16F707
- PIC16F716
- PIC16F72
- PIC16F720
- PIC16F721
- PIC16F722
- PIC16F722A
- PIC16F723
- PIC16F723A
- PIC16F724
- PIC16F726
- PIC16F727
- PIC16F73
- PIC16F737
- PIC16F74
- PIC16F747
- PIC16F753
- PIC16F76

**Demo & Eval Boards** | **Emulators & Debuggers** | Programmers

**PICkit 3 In-Circuit Debugger (PG164130)**  
**Header:** AC244035 (Optional)  
**Debug Features:**  
 Stop watch: True  
 Break on stack overflow: True  
 Pgm-memory HW breakpoints: 3  
 Data-memory breakpoints: 3  
 WDT overflow: True  
 Pass counter: True

**MPLAB ICD 3 In-Circuit Debugger (DV164035)**  
**Header:** AC244035 (Optional)  
**Debug Features:**  
 WDT overflow: True  
 Data-memory breakpoints: 3  
 Pgm-memory SW breakpoints: Unlimited  
 Pass counter: True  
 Break on stack overflow: True  
 Stop watch: True  
 Pgm-memory HW breakpoints: 3

**MPLAB REAL ICE PROBE KIT (DV244005)**  
**Header:** AC244035 (Optional)  
**Debug Features:**  
 Pgm-memory HW breakpoints: 3  
 Break on stack overflow: True  
 WDT overflow: True  
 Stop watch: True  
 Data-memory breakpoints: 3  
 Data capture: Enabled  
 Pgm-memory SW breakpoints: Unlimited  
 Pass counter: True  
**Accessories:** AC244008

**MPLAB ICD 2 MODULE (DV164005)**  
**Header:** AC244035 (Optional)

# PEP and Debug Header Specification

---

## 1.6 SUPPORT INFORMATION

Debug headers require specific debug tools to operate with MPLAB X IDE. Acquire these before purchasing a debug header in a Processor Extension Pak (PEP). Available PEPs are listed in [Chapter 2. “Required Debug Headers”](#) and [Chapter 3. “Optional Debug Headers”](#).

To continue setting up emulation header hardware, see [Section 1.7 “Debug Header Hardware Setup”](#).

Contact Customer Support for issues with emulation headers.

### 1.6.1 Tools Support

Debug headers are supported on the following tools:

- PICKit™ 3 in-circuit debugger
- MPLAB® ICD 3 in-circuit debugger
- MPLAB® REAL ICE® in-circuit emulator

### 1.6.2 Customer Support

Users of Microchip products can receive assistance through several channels:

- Distributor or Representative
- Local Sales Office
- Field Application Engineer (FAE)
- Technical Support

Technical support is available through the web site at: <http://support.microchip.com>

Documentation errors or comments may be sent to: [docerrors@microchip.com](mailto:docerrors@microchip.com).

## 1.7 DEBUG HEADER HARDWARE SETUP

To set up your header, perform the following steps:

1. Check the debug header for any stickers and the header box for any paper inserts that may specify special operating instructions (Figure 1-4). Follow these instructions before doing anything else.

**FIGURE 1-4: SPECIAL HEADER INSTRUCTIONS**

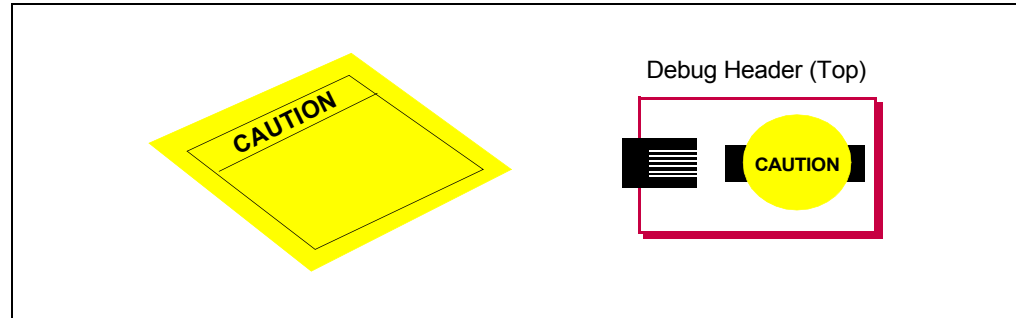

2. Set any jumpers or switches on the header to determine device functionality or selection, as specified for that header. See the sections “Optional Debug Headers” or “Required Debug Headers” for information on how to set up individual headers.
3. Connect the header to your desired debug tool by consulting the tool documentation for connection options. An example connection is shown in Figure 1-5.

The special -ICE/-ICD device is mounted on the top of a header and its signals are routed to the emulator or debugger connector. These special device versions are labeled with the appropriate suffix (e.g., *Device-ICE*).

**FIGURE 1-5: CONNECT HEADER TO DEBUG TOOL**

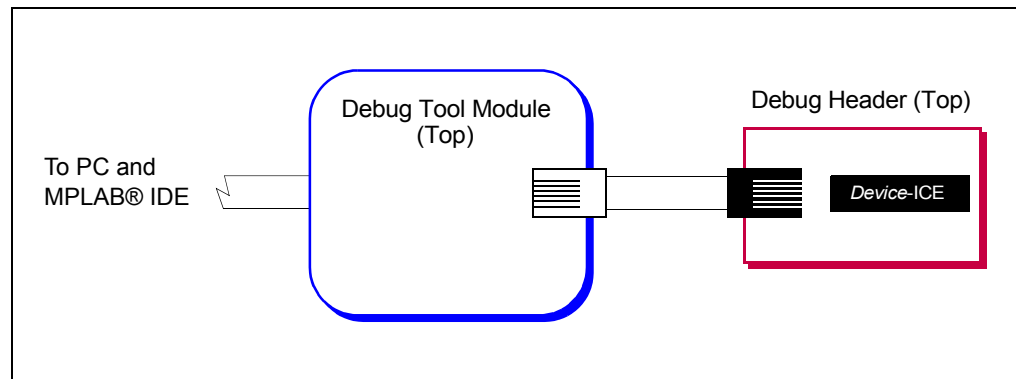

4. Connect the header to the target board. On the bottom of the header is a socket that is used to connect to the target board. The header can be connected to the target board as follows:
  - a) PDIP header socket to PDIP target socket with a stand-off (male-to-male) connector
  - b) Header socket to plug on the target board
  - c) Header socket to target socket with a transition socket (see the *Transition Socket Specification*, DS51194)

An example connection is shown in Figure 1-6.

# PEP and Debug Header Specification

The header socket will have the same pin count as your selected device. The -ICE/-ICD device on the top of the header usually has a larger pin count because it has additional pins that are dedicated to debug.

**FIGURE 1-6: CONNECT HEADER TO TARGET**

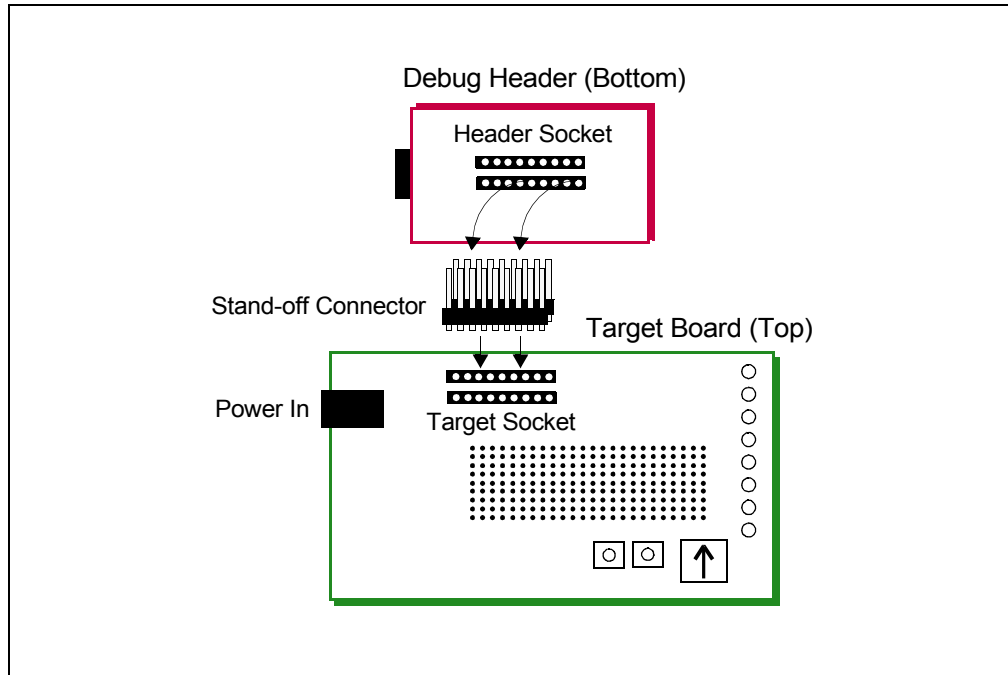

5. If using a debug tool that can power the target, power that tool now.
6. Power the target, if needed.

## 1.8 DEBUG HEADER SETUP FOR MPLAB X IDE

Follow these instructions to use the debug header:

1. Set up the debug header as specified in [Section 1.7 “Debug Header Hardware Setup”](#).
2. Begin creating a project for a device supported by your debug header using the Projects wizard (*File>New Project*). See MPLAB X IDE documentation for more on Projects.
3. In one step of the wizard you will have an opportunity to specify the debug header product number (AC#####).
4. In another step you will specify the hardware (debug) tool to which your header is attached.
5. Once the wizard is complete, write code for your project.
6. Select *Debug>Debug Project* to run and debug your code.

**Note:** A debug header can only be used to debug (Debug menu), not to program (Run menu). See [Section 1.9.1 “Programming Details”](#).

# PEP and Debug Header Specification

---

## 1.9 ADDITIONAL INFORMATION

The following additional information is useful when using a Debug Header from a Processor Extension Pak.

### 1.9.1 Programming Details

The debug header is designed to be used with the in-circuit emulator or the in-circuit debugger selected as a debugger, not a programmer, in MPLAB X IDE. Any programming of the special -ICE/-ICD device on the header is for debug purposes and includes the debug executive. See your related debug tool documentation for details on using it as a debugger.

To program production (non-special) devices with your debug tool, use the Universal Programming Module (AC162049) or design a modular interface connector on the target. See the appropriate specification for connections. For the most up-to-date device programming specifications, see the Microchip website ([www.microchip.com](http://www.microchip.com)).

Also, production devices may be programmed with the following tools:

- MPLAB PM3 device programmer
- PICkit 3 development programmer
- MPLAB ICD 3 in-circuit debugger (select as a programmer)
- MPLAB REAL ICE in-circuit emulator (select as a programmer)

### 1.9.2 Calibration Bits

The calibration bits for the band gap and internal oscillator are always preserved to their factory settings.

### 1.9.3 Performance Issues

PIC MCUs do not support partial program memory erase. Therefore, users may experience slower performance than with other devices.

Also, see either the in-circuit emulator or the in-circuit debugger Help file for information on specific device limitations that may affect performance.

## Chapter 2. Required Debug Headers

### INTRODUCTION

Some devices have no built-in debug circuitry. Therefore, special -ICE/-ICD versions of these devices are required for debug tool operation.

Currently available debug headers and their associated -ICE/-ICD devices are shown below, sorted by supported device.

**TABLE 1: REQUIRED DEBUG HEADERS BY DEVICE**

Device Supported by Debug Header	Pin Count	PEP* Part Number	-ICE/-ICD Device on Debug Header	VDD Max
PIC10F200/2/4/6	8/14	<a href="#">AC162059</a>	PIC16F505-ICD	5.5V
PIC10F220/2	8/14	<a href="#">AC162070</a>	PIC16F506-ICD	5.5V
PIC10F320/322	6/8	<a href="#">AC244045</a>	PIC10F320-ICE	5.5V
PIC10LF320/322	6/8	<a href="#">AC244045</a>	PIC10F320-ICE	3.6V
PIC12F508/509	8/14	<a href="#">AC162059</a>	PIC16F505-ICD	5.5V
PIC12F510	8/14	<a href="#">AC162070</a>	PIC16F506-ICD	5.5V
PIC12F519	8/14	<a href="#">AC162096</a>	PIC16F526-ICD	5.5V
PIC12F609/HV609	28	<a href="#">AC162083</a>	PIC16F616-ICD	5.5V
PIC12F615/HV615	28	<a href="#">AC162083</a>	PIC16F616-ICD	5.5V
PIC12F617	28	<a href="#">AC162083</a>	PIC16F616-ICD	5.5V
PIC12F629	8	<a href="#">AC162050</a>	PIC12F675-ICD	5.5V
PIC12F635	14	<a href="#">AC162057</a>	PIC16F636-ICD	5.5V
PIC12F675	8	<a href="#">AC162050</a>	PIC12F675-ICD	5.5V
PIC12F683	8	<a href="#">AC162058</a>	PIC12F683-ICD	5.5V
PIC12F1501 <sup>(1)</sup>	8	<a href="#">AC244051</a>	PIC16F1509-ICE	5.5V
PIC12LF1501 <sup>(1)</sup>	8	<a href="#">AC244052</a>	PIC16LF1509-ICE	3.6V
PIC16F505	8/14	<a href="#">AC162059</a>	PIC16F505-ICD	5.5V
PIC16F506	8/14	<a href="#">AC162070</a>	PIC16F506-ICD	5.5V
PIC16F526	8/14	<a href="#">AC162096</a>	PIC16F526-ICD	5.5V
PIC16F527	20	<a href="#">AC244061</a>	PIC16F527-ICD	5.5V
PIC16F570	28	<a href="#">AC244062</a>	PIC16F570-ICD	5.5V
PIC16F610/HV610	14/16	<a href="#">AC162083</a>	PIC16F616-ICD	5.5V
PIC16F616/HV616	14/16	<a href="#">AC162083</a>	PIC16F616-ICD	5.5V
PIC16F627A/628A	18	<a href="#">AC162053</a>	PIC16F648A-ICD	5.5V
PIC16F630	14	<a href="#">AC162052</a>	PIC16F676-ICD	5.5V
PIC16F631	20	<a href="#">AC162061</a>	PIC16F690-ICD	5.5V
PIC16F636	14	<a href="#">AC162057</a>	PIC16F636-ICD	5.5V
PIC16F639 <sup>(3)</sup>	20	<a href="#">AC162066</a>	PIC16F636-ICD	5.5V

\* PEP = Processor Extension Pak.

**Note 1:** Header optional for other devices, but required for this device.

**Note 2:** VDDCORE Max

**Note 3:** Dual die

# PEP and Debug Header Specification

**TABLE 1: REQUIRED DEBUG HEADERS BY DEVICE (CON'T)**

Device Supported by Debug Header	Pin Count	PEP* Part Number	-ICE/-ICD Device on Debug Header	VDD Max
PIC16F648A	18	AC162053	PIC16F648A-ICD	5.5V
PIC16F676	14	AC162052	PIC16F676-ICD	5.5V
PIC16F677	20	AC162061	PIC16F690-ICD	5.5V
PIC16F684	14	AC162055	PIC16F684-ICD	5.5V
PIC16F685/687	20	AC162061	PIC16F690-ICD	5.5V
PIC16F688	14	AC162056	PIC16F688-ICD	5.5V
PIC16F689/690	20	AC162061	PIC16F690-ICD	5.5V
PIC16F716	18	AC162054	PIC16F716-ICD	5.5V
PIC16F785/HV785	20	AC162060	PIC16F785-ICD	5.5V
PIC16F1503 <sup>(1)</sup> PIC16F1507 <sup>(1)</sup>	14 20	AC244051	PIC16F1509-ICE	5.5V
PIC16LF1503 <sup>(1)</sup> PIC16LF1507 <sup>(1)</sup>	14 20	AC244052	PIC16LF1509-ICE	3.6V
PIC18F13K50 PIC18F14K50	20	AC244023	PIC18F14K50-ICE	5.5V
PIC18LF13K50 PIC18LF14K50	20	AC244024	PIC18LF14K50-ICE	3.6V, 2.75V <sup>(2)</sup>
PIC24F04KA200 <sup>(1)</sup> PIC24F04KA201 <sup>(1)</sup>	14 20	AC244028	PIC24F16KA102-ICE	3.6V

\* PEP = Processor Extension Pak.

**Note 1:** Header optional for other devices, but required for this device.

**Note 2:** VDDCORE Max

**Note 3:** Dual die

## AC162050, AC162058

### Header Identification

The AC number is used for ordering the Processor Extension Pak, which contains the debug header. However, this number is not on the header, as the board may be used for multiple headers by inserting various -ICE/-ICD devices. To identify these headers, use the following information.

AC Number	-ICE/-ICD Device	Board Assembly Number
AC162050	PIC12F675-ICD	02-01662
AC162058	PIC12F683-ICD	

### Header Setup and Operation

For these headers, device peripherals need to be selected by setting jumper J1 to the appropriate position. For AC162050, this will have the effect of selecting the device.

AC Number	Jumper J1	Function	Device Selected
AC162050	2-3	A/D Disabled	PIC12F629
	1-2	A/D Enabled	PIC12F675
AC162058	1-2	A/D Enabled	PIC12F683



# Required Debug Headers

## Header Limitations

Sometimes a header device (-ICE/-ICD) has operational issues or errata. To determine if a device on a header has limitations, see your hardware tool documentation.

## Header Dimensions

The figure below lists the dimensions for the debug header. Dimensions are design values in inches.

If the length and/or width of the debug header is too large a footprint for the target board, consider using stand-offs, transition sockets or other extenders in the header connection socket to raise the header above the target.

**FIGURE 2-1: DIMENSIONS – AC162050, AC162058**

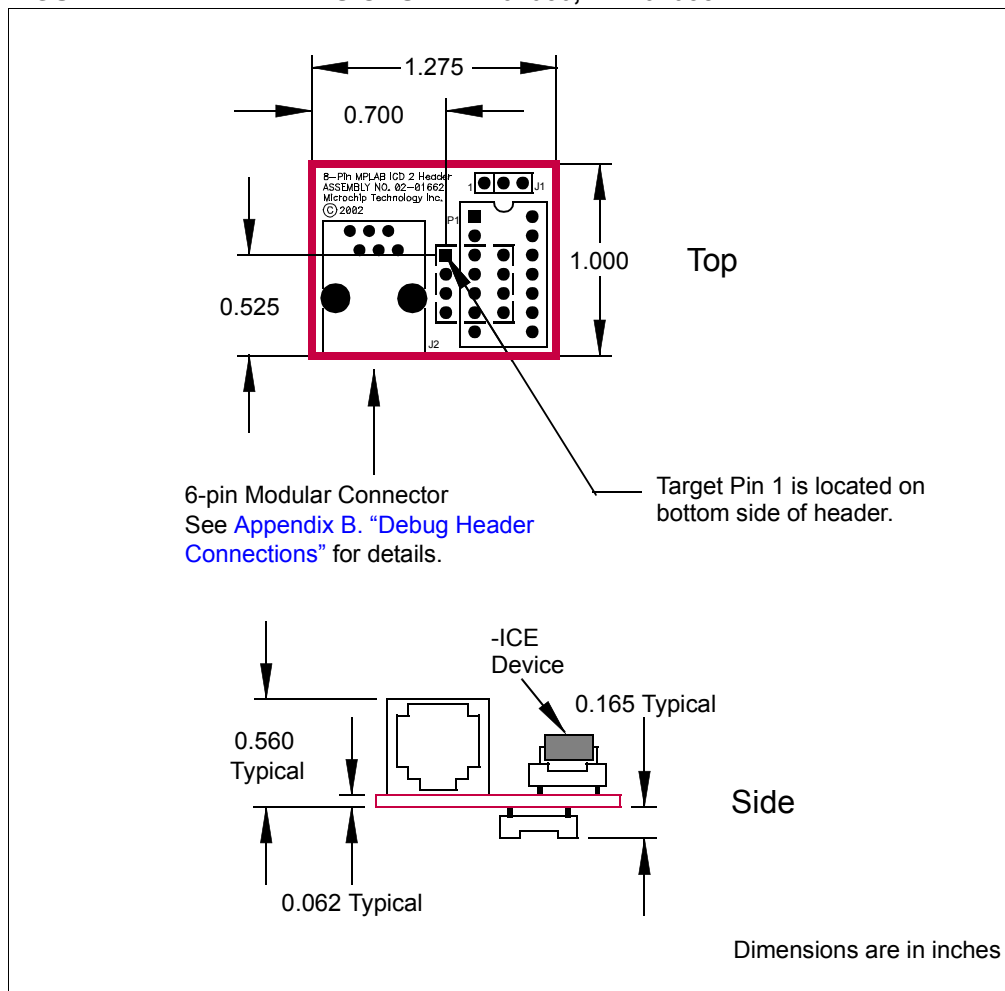

# PEP and Debug Header Specification

---

## AC162052, AC162055, AC162056, AC162057

### Header Identification

The AC number is used for ordering the Processor Extension Pak, which contains the debug header. However, this number is not on the header, as the board may be used for multiple headers by inserting various -ICE/-ICD devices. To identify these headers, use the following information.

AC Number	-ICE/-ICD Device	Board Assembly Number
AC162052	PIC16F676-ICD	02-01686
AC162055	PIC16F684-ICD	
AC162056	PIC16F688-ICD	
AC162057	PIC16F636-ICD	

### Header Setup and Operation

For these headers, device peripherals need to be selected by setting jumper J1 to the appropriate position. For AC162052 and AC162057, this will have the effect of selecting the device.

AC Number	Jumper J1	Function	Device Selected
AC162052	2-3	A/D Disabled	PIC16F630
	1-2	A/D Enabled	PIC16F676
AC162055	Don't care	N/A	PIC16F684
AC162056	Don't care	N/A	PIC16F688
AC162057	2-3	PORTC, Comparator 2 Disabled	PIC12F635
	1-2	PORTC, Comparator 2 Enabled	PIC16F636

### Header Limitations

Sometimes a header device (-ICE/-ICD) has operational issues or errata. To determine if a device on a header has limitations, see your hardware tool documentation.

# Required Debug Headers

## Header Dimensions

The figure below lists the dimensions for the debug header. Dimensions are design values in inches.

If the length and/or width of the debug header is too large a footprint for the target board, consider using stand-offs, transition sockets or other extenders in the header connection socket to raise the header above the target.

**FIGURE 2-2: DIMENSIONS – AC162052, AC162055, AC162056, AC162057**

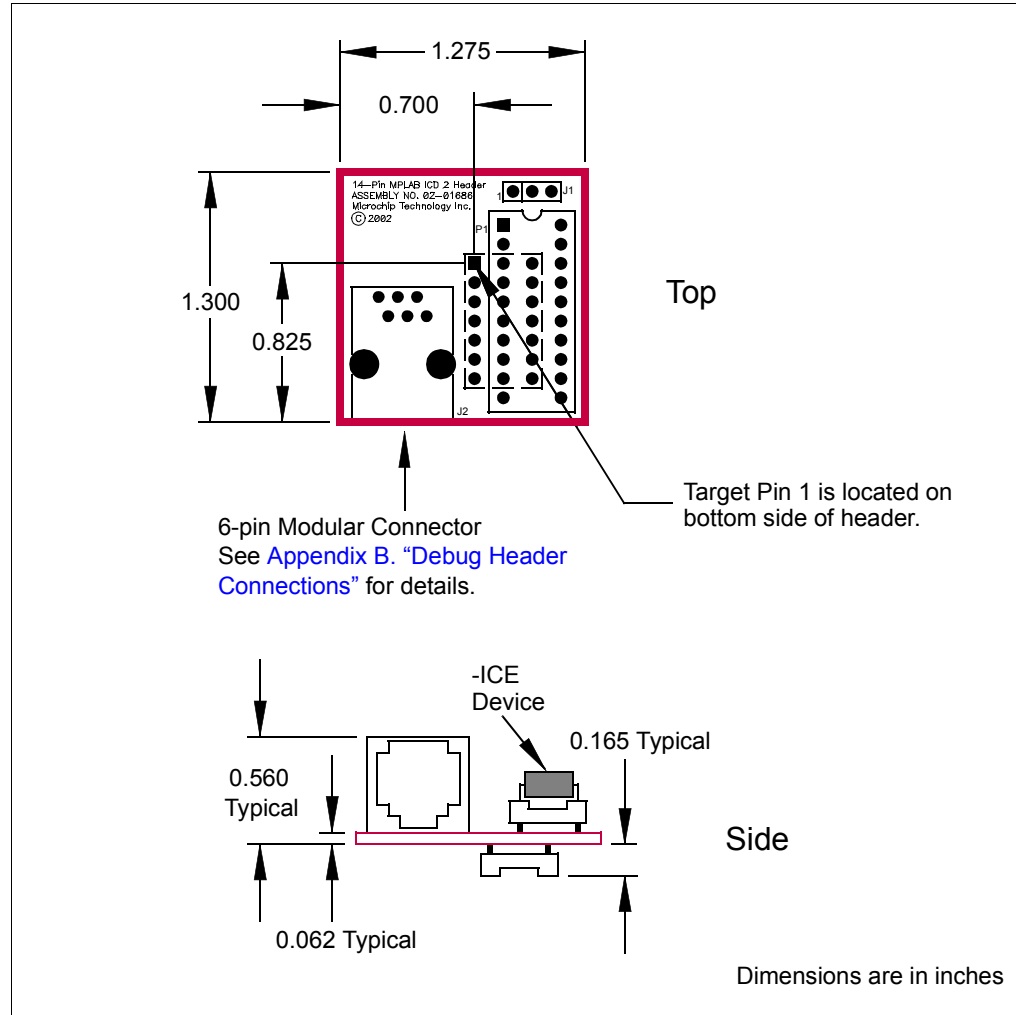

# PEP and Debug Header Specification

---

## AC162053, AC162054

### Header Identification

The AC number is used for ordering the Processor Extension Pak, which contains the debug header. However, this number is not on the header, as the board may be used for multiple headers by inserting different -ICE/-ICD devices. To identify these headers, use the following information.

AC Number	-ICE/-ICD Device	Board Assembly Number
AC162053	PIC16F648A-ICD	02-01695
AC162054	PIC16F716-ICD	

### Header Setup and Operation – AC162053

For these headers, there are no jumpers/switches. The device with the most program memory is always selected.

If PIC16F627A or PIC16F628A devices are selected for development in MPLAB X IDE, the warning “Invalid target device ID” may be received in the build window. Ignore this warning. The reason for the warning is that the PIC16F648A-ICD device supports PIC16F648A, PIC16F627A and PIC16F628A, but only reports the device ID for the PIC16F648A.

### Header Setup and Operation – AC162054

This header supports one device (PIC16F716) so there are no jumpers or switches.

### Header Limitations

Sometimes a header device (-ICE/-ICD) has operational issues or errata. To determine if a device on a header has limitations, see your hardware tool documentation.

# Required Debug Headers

## Header Dimensions

The figure below lists the dimensions for the debug header. Dimensions are design values in inches.

If the length and/or width of the debug header is too large a footprint for the target board, consider using stand-offs, transition sockets or other extenders in the header connection socket to raise the header above the target.

**FIGURE 2-3: DIMENSIONS – AC162053, AC162054**

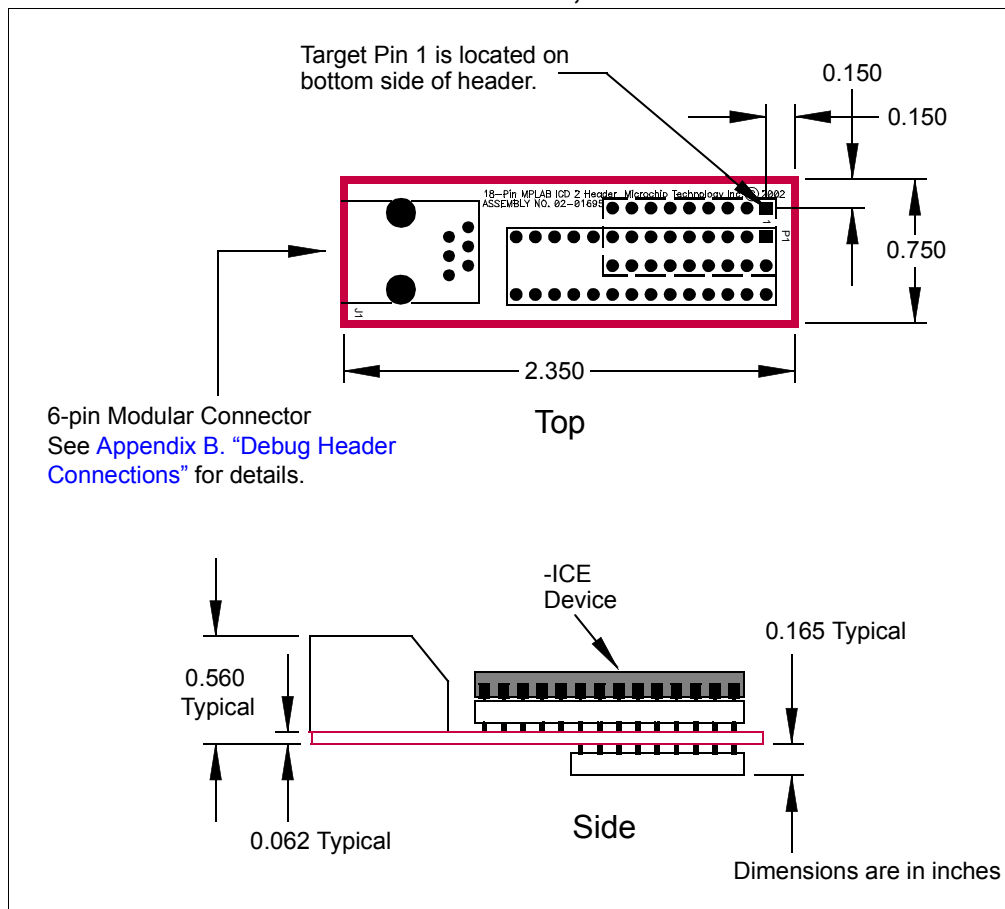

# PEP and Debug Header Specification

---

## AC162059, AC162070, AC162096

### Header Identification

The AC number is used for ordering the Processor Extension Pak, which contains the debug header. However, this number is not on the header, as the board may be used for multiple headers by inserting different -ICE/-ICD devices. To identify these headers, use the following information.

AC Number	-ICE/-ICD Device	Board Assembly Number
AC162059	PIC16F505-ICD	02-01803
AC162070	PIC16F506-ICD	
AC162096	PIC16F526-ICD	

### Header Setup and Operation

The -ICD devices on these headers are specifically designed to select a device without the use of additional jumpers or switches.

These headers support 8- and 14-pin devices (see [Figure 2-4](#).) For the AC162059 and AC162070, there is an 8-pin and a 14-pin connector. For the AC162096, there is only a 14-pin connector. (The 8-pin connector is not populated.) Use the 14-pin connector for 8-pin devices, but make sure device pin 1 is placed at the 14-pin connector pin 1.

### Header Limitations

Sometimes a header device (-ICE/-ICD) has operational issues or errata. To determine if a device on a header has limitations, see your hardware tool documentation.

# Required Debug Headers

## Header Dimensions

The figure below lists the dimensions for the debug header. Dimensions are design values in inches.

If the length and/or width of the debug header is too large a footprint for the target board, consider using stand-offs, transition sockets or other extenders in the header connection socket to raise the header above the target.

**FIGURE 2-4: DIMENSIONS – AC162059, AC162070, AC162096**

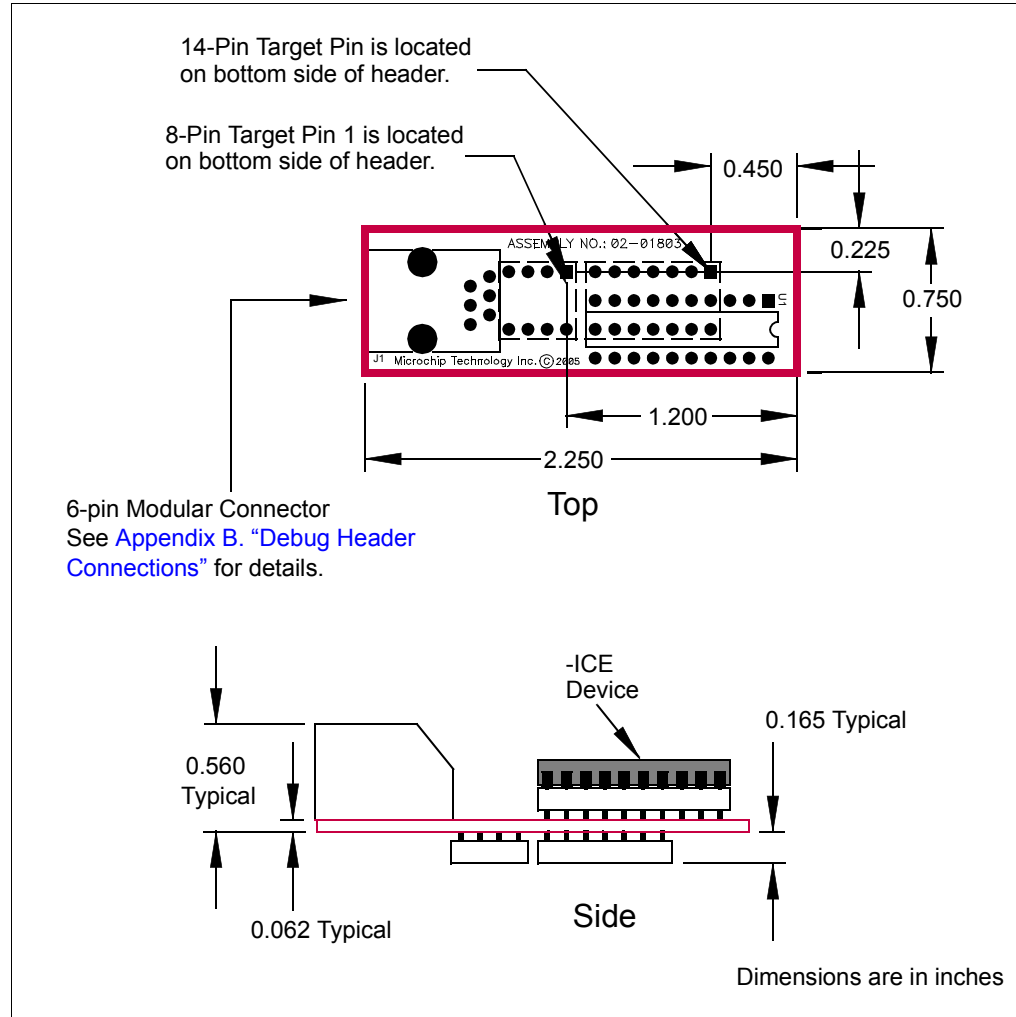

# PEP and Debug Header Specification

---

## AC162060

### Header Identification

The AC number is used for ordering the Processor Extension Pak, which contains the debug header. However, this number is not on the header, as the board may be used for multiple headers by inserting different -ICE/-ICD devices. To identify this header, use the following information.

AC Number	-ICE/-ICD Device	Board Assembly Number
AC162060	PIC16F785-ICD	02-01820

### Header Setup and Operation

For the PIC16F785 20-pin header, connect the jumper J2 to enable the shunt regulator.

Device	Device Type	Jumper J2	Function
PIC16F785	F	1-2	Disable shunt regulator
PIC16HV785	HV	2-3	Enable shunt regulator

### Header Limitations

Sometimes a header device (-ICE/-ICD) has operational issues or errata. To determine if a device on a header has limitations, see your hardware tool documentation.



# Required Debug Headers

## Header Dimensions

The figure below lists the dimensions for the debug header. Dimensions are design values in inches.

If the length and/or width of the debug header is too large a footprint for the target board, consider using stand-offs, transition sockets or other extenders in the header connection socket to raise the header above the target.

**FIGURE 2-5: DIMENSIONS – AC162060**

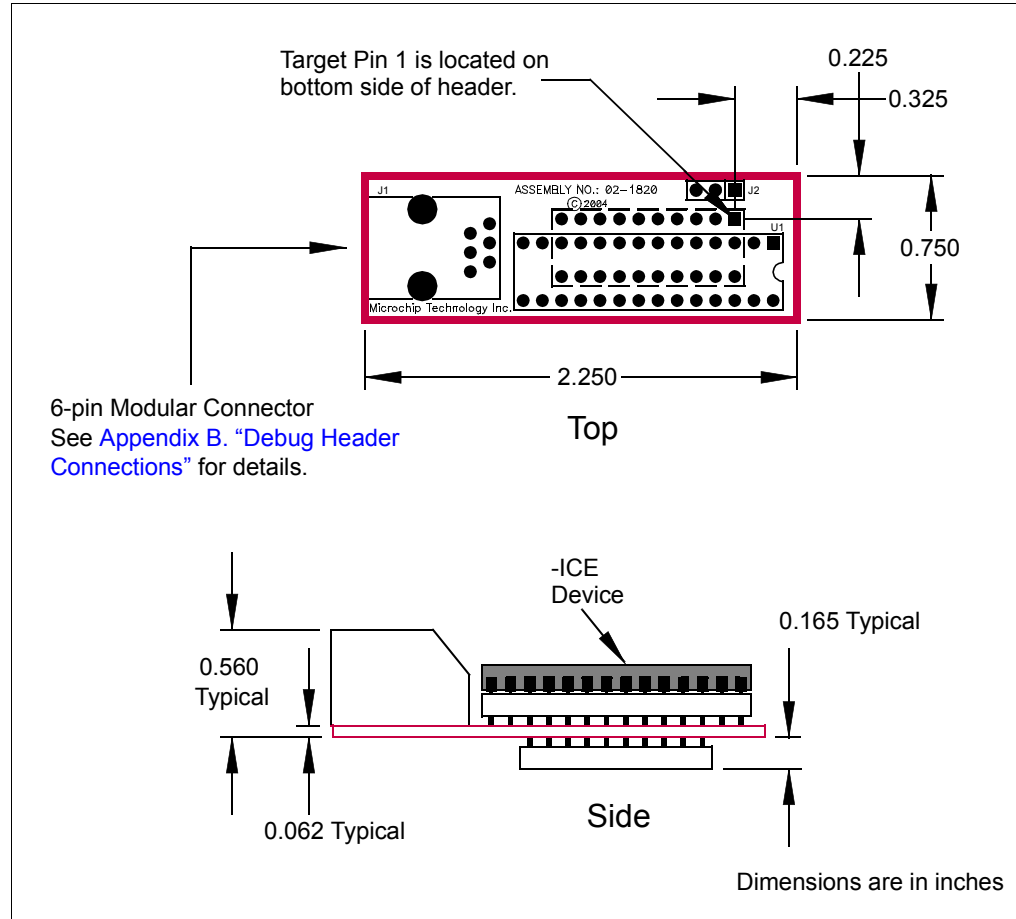

# PEP and Debug Header Specification

## AC162061

### Header Identification

The AC number is used for ordering the Processor Extension Pak, which contains the debug header. However, this number is not on the header, as the board may be used for multiple headers by inserting different -ICE/-ICD devices. To identify this header, use the following information.

AC Number	-ICE/-ICD Device	Board Assembly Number
AC162061	PIC16F690-ICD	02-01835

### Header Setup and Operation

For the PIC16F690 20-pin header, you will need to set the S1 switches (Figure 2-6) to enable peripherals and choose devices (Table 2).

FIGURE 2-6: S1 SWITCH HARDWARE

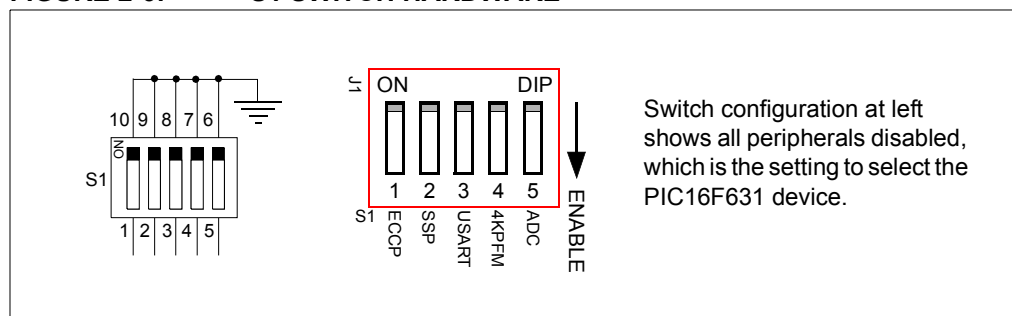

TABLE 2: S1 SWITCH DEVICE SELECTION

Device	Switches				
	1 ECCP	2 SSP	3 USART	4 4k PFM	5 ADC
PIC16F631	0	0	0	0*	0
PIC16F677	0	1	0	0**	1
PIC16F685	1	0	0	1	1
PIC16F687	0	1	1	0**	1
PIC16F689	0	1	1	1	1
PIC16F690	1	1	1	1	1

Legend: 1 = Enabled 0 = Disabled \* = 1k PFM \*\* = 2k PFM

### Header Limitations

Sometimes a header device (-ICE/-ICD) has operational issues or errata. To determine if a device on a header has limitations, see your hardware tool documentation.

# Required Debug Headers

## Header Dimensions

The figure below lists the dimensions for the debug header. Dimensions are design values in inches.

If the length and/or width of the debug header is too large a footprint for the target board, consider using stand-offs, transition sockets or other extenders in the header connection socket to raise the header above the target.

**FIGURE 2-7: DIMENSIONS – AC162061**

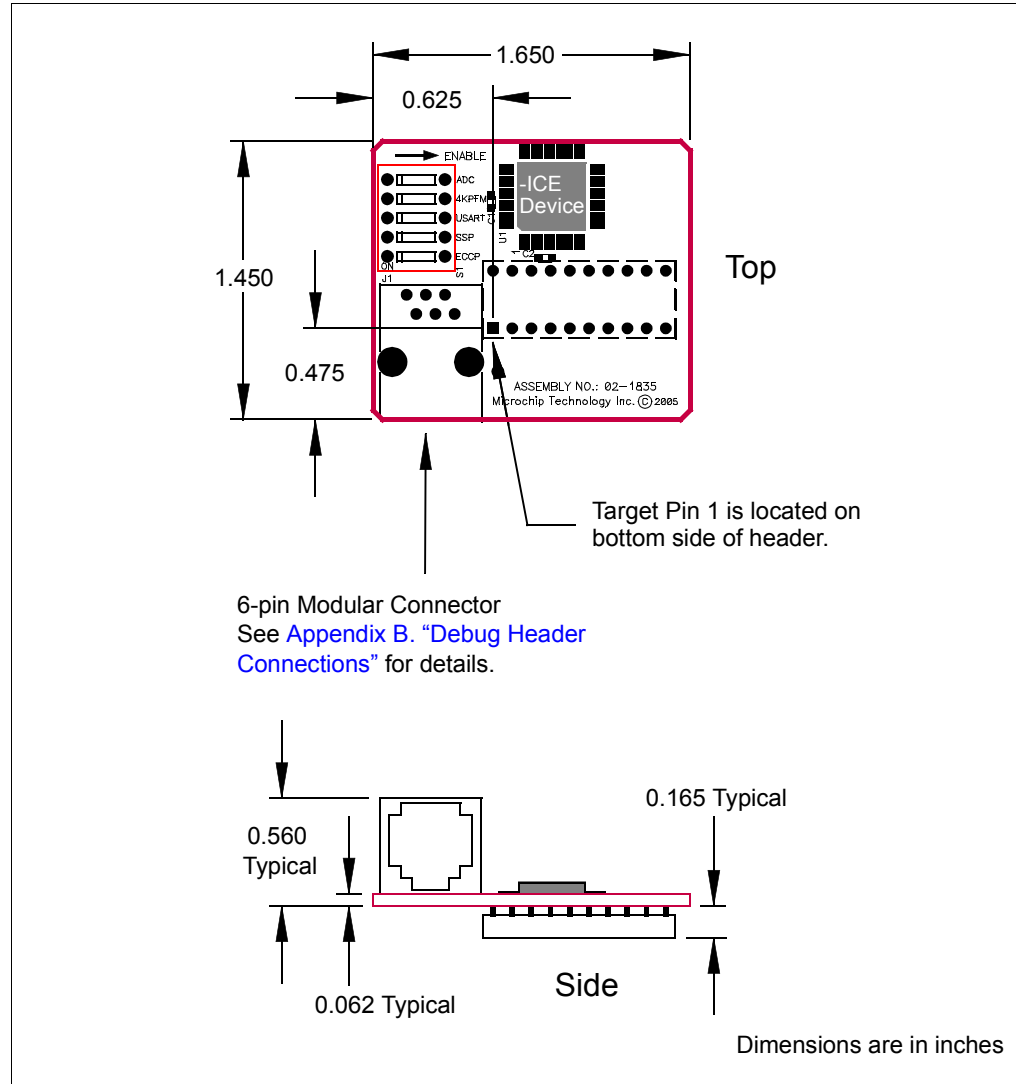

# PEP and Debug Header Specification

---

## AC162066

### Header Identification

The AC number is used for ordering the Processor Extension Pak, which contains the debug header. However, this number is not on the header, as the board may be used for multiple headers by inserting different -ICE/-ICD devices. To identify this header, use the following information.

AC Number	-ICE/-ICD Device	Board Assembly Number
AC162066	PIC16F636-ICD	02-01832

### Header Setup and Operation

For the PIC16F639 20-pin header, connect the jumper J3 as specified below.

Tool	Jumper J3	Function
N/A	1-2	Run/program as production device
In-circuit debuggers, next generation in-circuit emulators	2-3	Run/program as debug device

### Header Limitations

Sometimes a header device (-ICE/-ICD) has operational issues or errata. To determine if a device on a header has limitations, see your hardware tool documentation.

# Required Debug Headers

## Header Dimensions

The figure below lists the dimensions for the debug header. Dimensions are design values in inches.

If the length and/or width of the debug header is too large a footprint for the target board, consider using stand-offs, transition sockets or other extenders in the header connection socket to raise the header above the target.

**FIGURE 2-8: DIMENSIONS – AC162066**

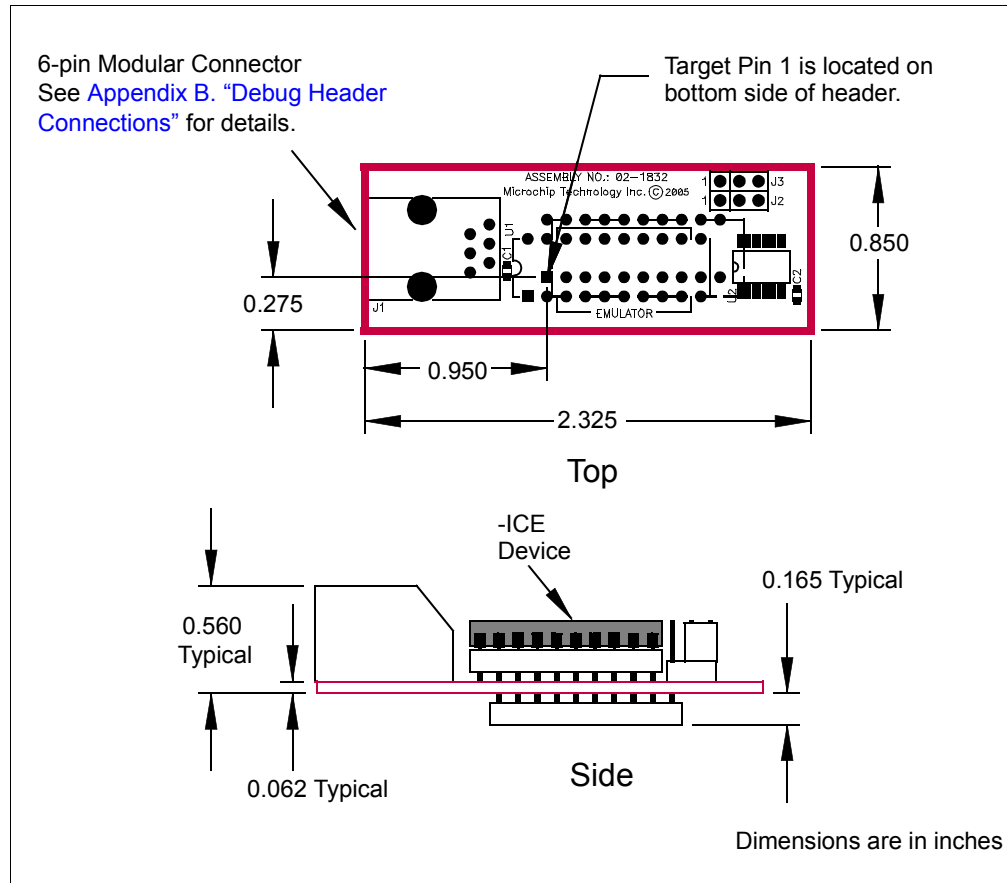

# PEP and Debug Header Specification

AC162083

## Header Identification

The AC number is used for ordering the Processor Extension Pak, which contains the debug header. However, this number is not on the header, as the board may be used for multiple headers by inserting different -ICE/-ICD devices. To identify this header, use the following information.

AC Number	-ICE/-ICD Device	Board Assembly Number
AC162083	PIC16F616-ICD	02-01976

## Header Setup and Operation

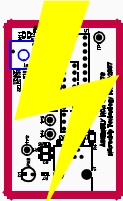
<b>CAUTION</b>	
	<p><b>Header damage.</b> Incorrect rotary switch (Figure 2-9) settings can irreparably damage the header. Ensure rotary switch settings are correct (Table 3) before powering or connecting the header. Do not change the rotary switch setting while the header is powered or connected to a debug tool. Do not power shunt regulator (HV) devices from the debug tool.</p>

Test points are available on this header to check the following: Ground (TP1), VDD (TP2), ICD Clock (TP3), ICD Data (TP4) and ICD MCLR/VPP (TP5).

**TABLE 3: ROTARY SWITCH SETTINGS**

Switch Position	Device	Switch Position	Device
0	PIC12HV609	8	PIC12F609
1	PIC12HV615	9	PIC12F615
2	Reserved HV	A	PIC12F617
3	PIC16HV610	B	PIC16F610
4	PIC16HV616	C	PIC16F616
5	Reserved HV	D	Reserved F
6	Reserved HV	E	Reserved F
7	Reserved HV	F	Reserved F

Also, see the AC162083 Insert (DS51693).

### POTENTIAL ISSUES

#### **HV device selected instead of F device**

If you inadvertently select a shunt regulator (HV) device and attempt to use it in a target board designed for a non-shunt regulator (F) device, the shunt may draw excessive current due to the lack of current-limiting circuitry on the target board and damage the device mounted on the header.

#### **F device selected instead of HV device**

If you inadvertently select a non-shunt regulator (F) device and attempt to use it in a target board designed for a shunt regulator (HV) device, the device may draw excessive current due to the higher voltage used on a target board designed for HV devices and damage the device mounted on the header.

# Required Debug Headers

## HV devices cannot be powered from debug tool

Do not select in MPLAB X IDE to power the target (debug header) from the debug tool (if it supports powering the target) when using shunt regulator (HV) devices since this will also cause the shunt to draw excessive current.

## DETERMINING DAMAGE

A damaged header will cause MPLAB X IDE to report a device ID of 0. However, there are other issues that can cause the device ID to report as 0. Consult your debug tool documentation on troubleshooting to identify the problem. If you believe you have a damaged header, contact Microchip technical support at <http://support.microchip.com>.

## Header Limitations

Sometimes a header device (-ICE/-ICD) has operational issues or errata. To determine if a device on a header has limitations, see your hardware tool documentation.

## Header Dimensions

The figure below lists the dimensions for the debug header. Dimensions are design values in inches.

If the length and/or width of the debug header is too large a footprint for the target board, consider using stand-offs, transition sockets or other extenders in the header connection socket to raise the header above the target.

**FIGURE 2-9: DIMENSIONS – AC162083**

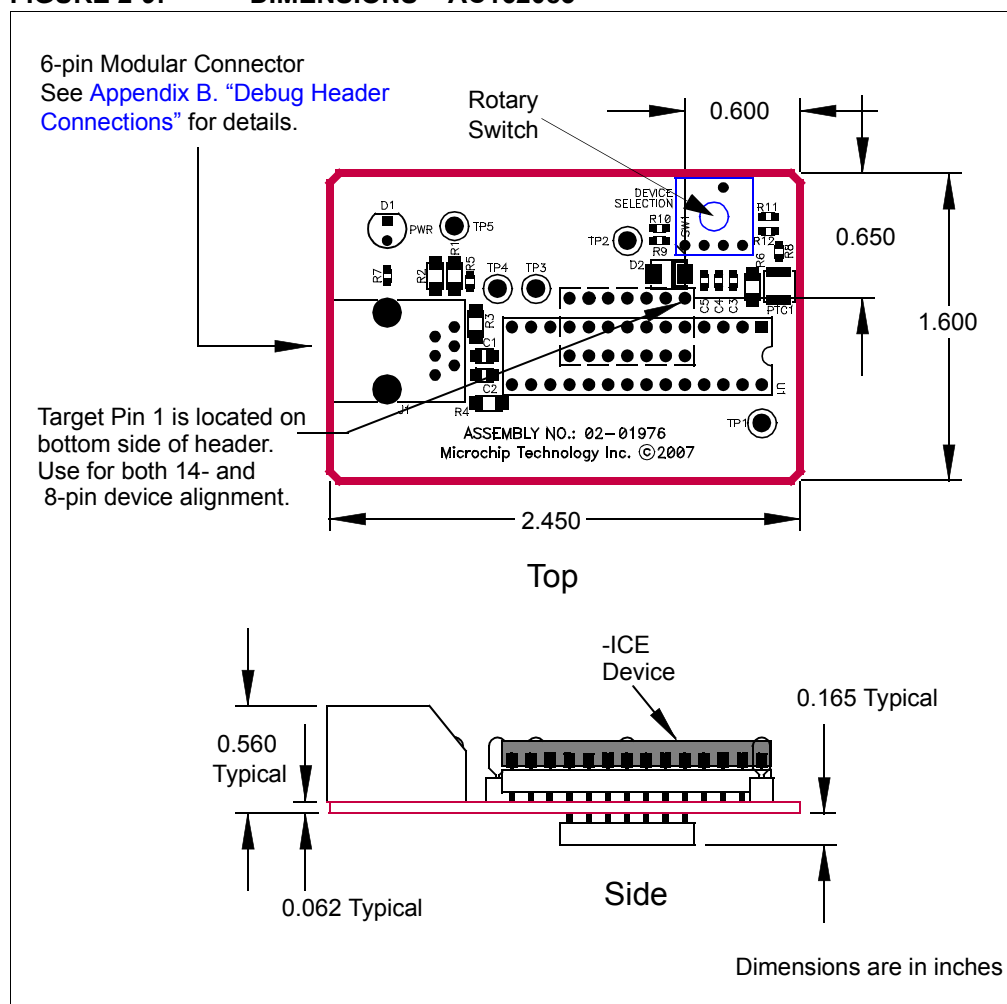

# PEP and Debug Header Specification

---

## AC244023, AC244024

### Header Identification

The AC number is used for ordering the Processor Extension Pak, which contains the debug header. However, this number is not on the header, as the board may be used for multiple headers by inserting different -ICE/-ICD devices. To identify these headers, use the following information.

AC Number	-ICE/-ICD Device	Board Assembly Number
AC244023	PIC18F14K50-ICE	02-02031
AC244024	PIC18LF14K50-ICE	

### Header Setup and Operation

For these headers, there are no jumpers/switches. MPLAB X IDE will use its selected device to choose the correct device to emulate.

### Header Limitations

Sometimes a header device (-ICE/-ICD) has operational issues or errata. To determine if a device on a header has limitations, see your hardware tool documentation.



# Required Debug Headers

## Header Dimensions

The figure below lists the dimensions for the debug header. Dimensions are design values in inches.

If the length and/or width of the debug header is too large a footprint for the target board, consider using stand-offs, transition sockets or other extenders in the header connection socket to raise the header above the target.

**FIGURE 2-10: DIMENSIONS – AC244023, AC224024**

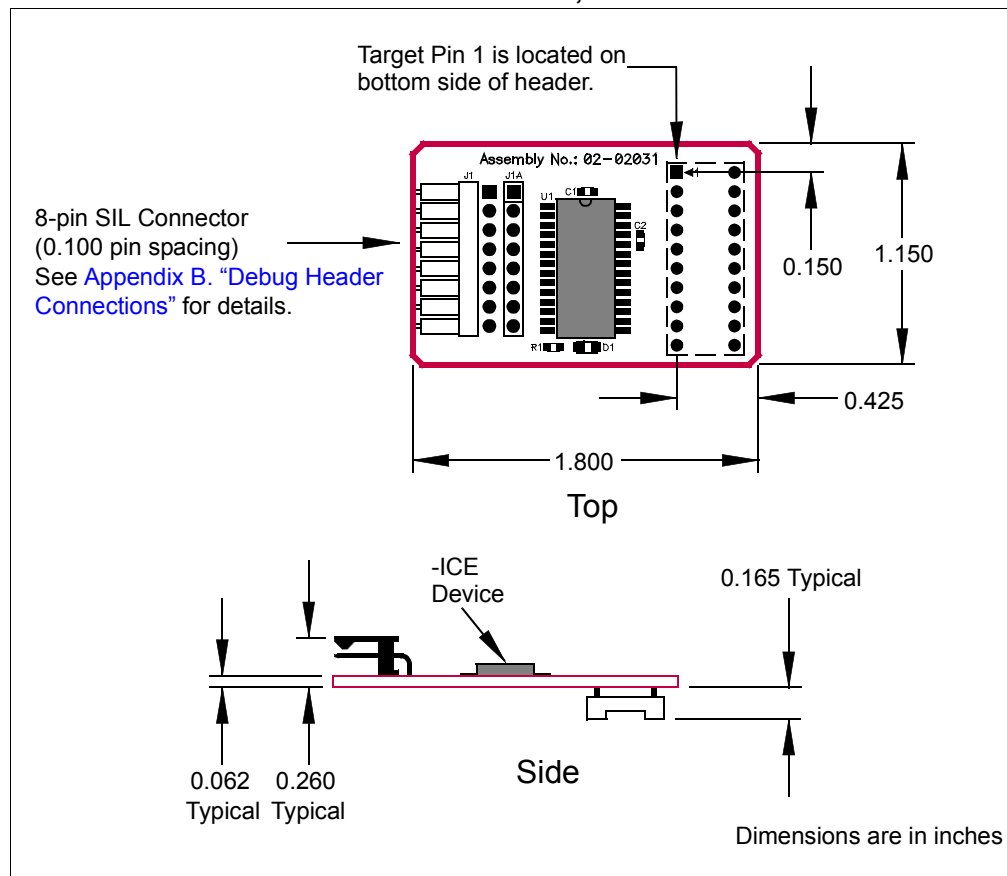

# PEP and Debug Header Specification

---

## AC244028

### Header Identification

The AC number is used for ordering the Processor Extension Pak, which contains the debug header. However, this number is not on the header, as the board may be used for multiple headers by inserting different -ICE/-ICD devices. To identify this header, use the following information.

AC Number	-ICE/-ICD Device	Board Assembly Number
AC244028	PIC24F16KA102-ICE	02-02107

### Header Setup and Operation

For this header, set up jumpers J2 and J3 as specified below.

Jumper	Setting	Function
J2	Open	Disable weak ICE/ $\overline{\text{MCLR}}$ pull-up resistor
	Short	Enable weak ICE/ $\overline{\text{MCLR}}$ pull-up resistor
J3	Open	Disable power LED indicator
	Short	Enable power LED indicator

### Header Limitations

Sometimes a header device (-ICE/-ICD) has operational issues or errata. To determine if a device on a header has limitations, see your hardware tool documentation.

# Required Debug Headers

## Header Dimensions

The figure below lists the dimensions for the debug header. Dimensions are design values in inches.

If the length and/or width of the debug header is too large a footprint for the target board, consider using stand-offs, transition sockets or other extenders in the header connection socket to raise the header above the target.

**FIGURE 2-11: DIMENSIONS - AC244028**

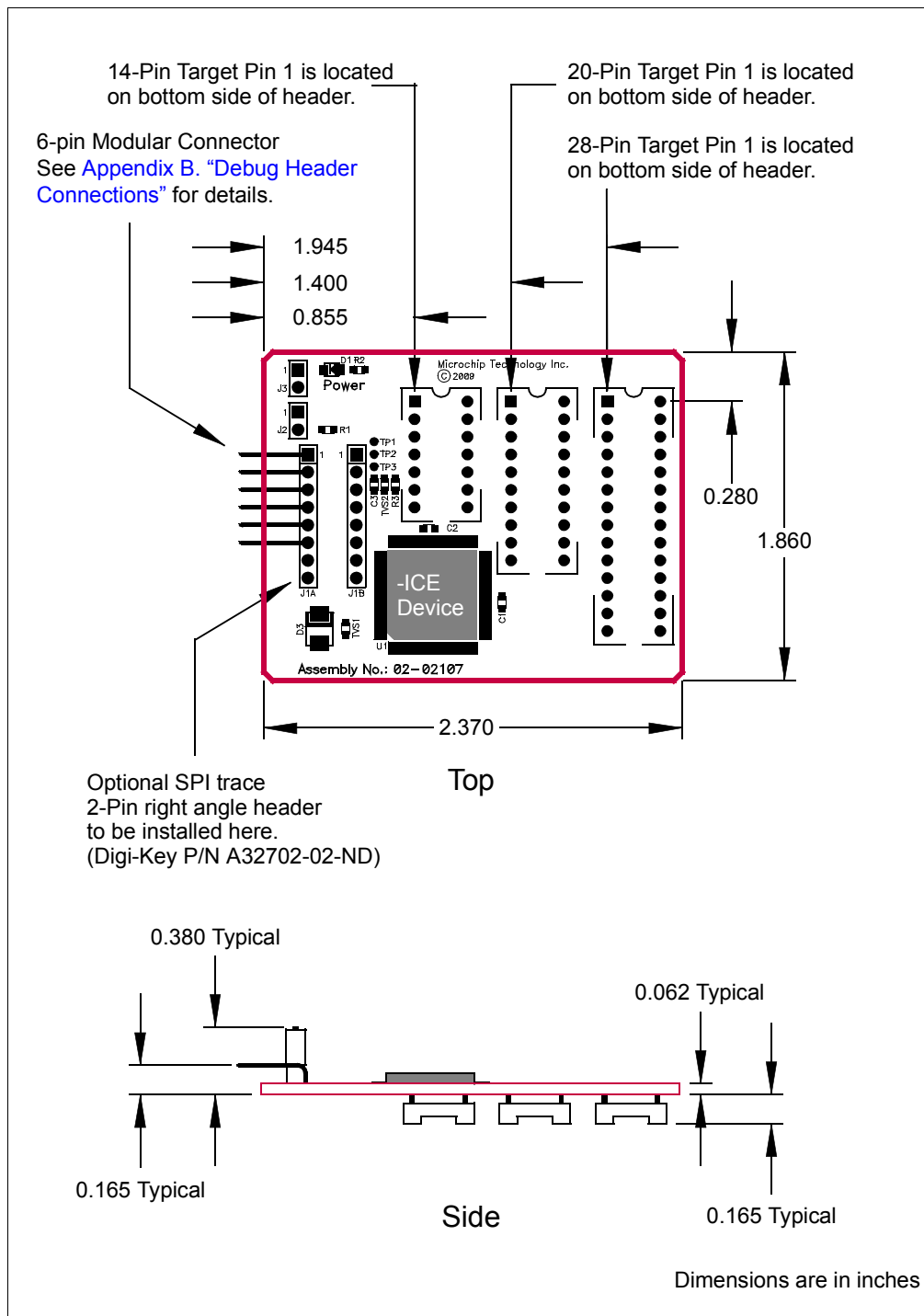

# PEP and Debug Header Specification

---

## AC244045

### Header Identification

The AC number is used for ordering the Processor Extension Pak, which contains the debug header. However, this number is not on the header, as the board may be used for multiple headers by inserting different -ICE/-ICD devices. To identify this header, use the following information.

AC Number	-ICE/-ICD Device	Board Assembly Number
AC244045	PIC10F320-ICE	02-02255

### Header Setup and Operation

Because the -ICE chip is based on the PIC10F320 device, the ICE device memory will be greater than the actual chip for the PIC10F322 device.

### Header Limitations

Sometimes a header device (-ICE/-ICD) has operational issues or errata. To determine if a device on a header has limitations, see your hardware tool documentation.

# Required Debug Headers

## Header Dimensions

The figure below lists the dimensions for the debug header. Dimensions are design values in inches.

If the length and/or width of the debug header is too large a footprint for the target board, consider using stand-offs, transition sockets or other extenders in the header connection socket to raise the header above the target.

**FIGURE 2-12: DIMENSIONS - AC244045**

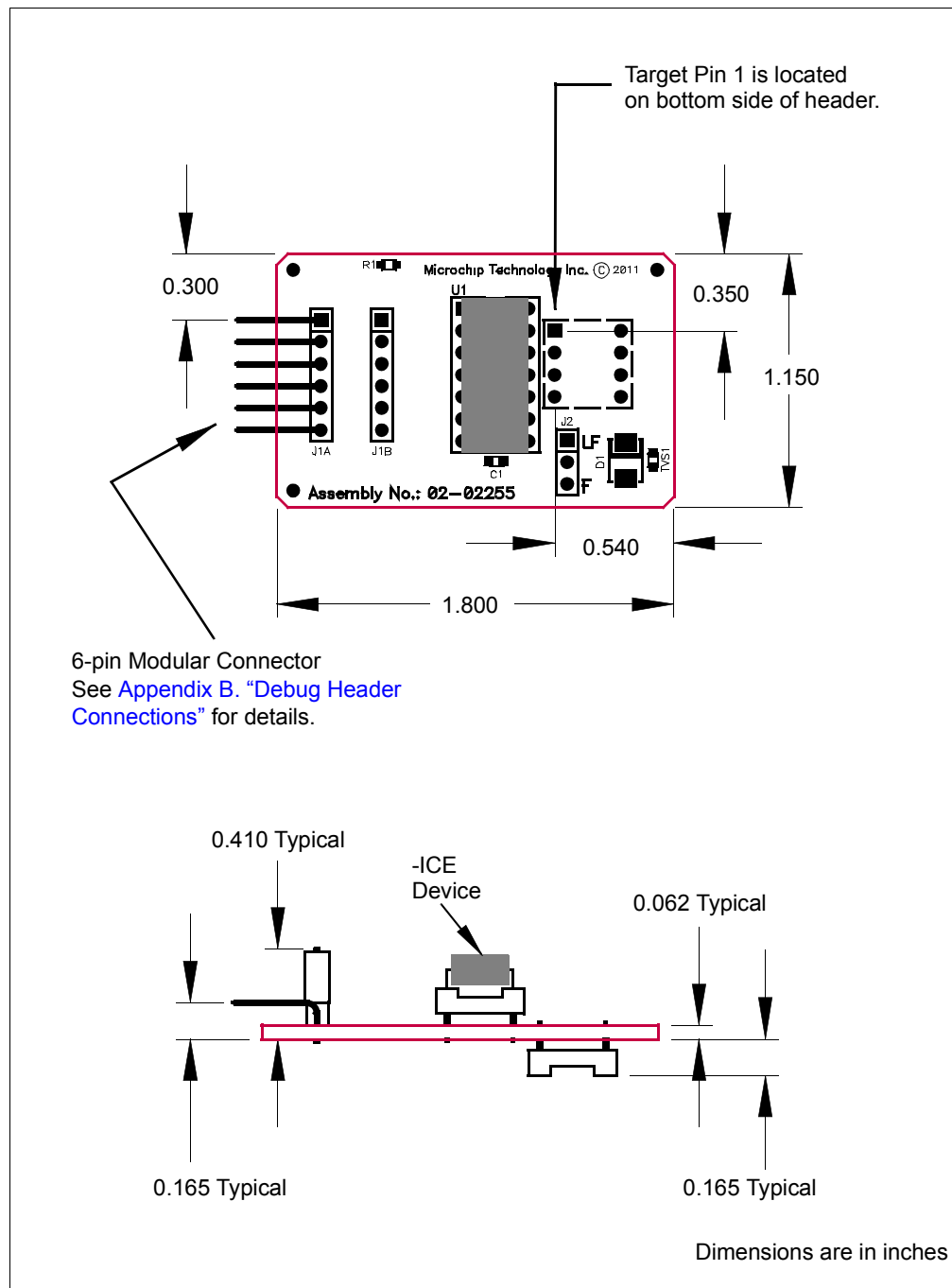

# PEP and Debug Header Specification

---

## AC244051, AC244052, AC244061

### Header Identification

The AC number is used for ordering the Processor Extension Pak, which contains the debug header. However, this number is not on the header, as the board may be used for multiple headers by inserting different -ICE/-ICD devices. To identify these headers, use the following information.

AC Number	-ICE/-ICD Device	Board Assembly Number
AC244051	PIC16F1509-ICE	02-02208
AC244052	PIC16LF1509-ICE	
AC244061	PIC16F527-ICD	

### Header Setup and Operation

For these headers, there are no jumpers/switches. MPLAB X IDE will use its selected device to choose the correct device to emulate.

These headers support 8-, 14- and 20-pin devices. For 8- and 14-pin devices, make sure device pin 1 is placed at the 20-pin connector pin 1.

### Header Limitations

Sometimes a header device (-ICE/-ICD) has operational issues or errata. To determine if a device on a header has limitations, see your hardware tool documentation.

# Required Debug Headers

## Header Dimensions

The figure below lists the dimensions for the debug headers. Dimensions are design values in inches.

If the length and/or width of the debug header is too large a footprint for the target board, consider using stand-offs, transition sockets or other extenders in the header connection socket to raise the header above the target.

**FIGURE 2-13: DIMENSIONS - AC244051, AC244052, AC244061**

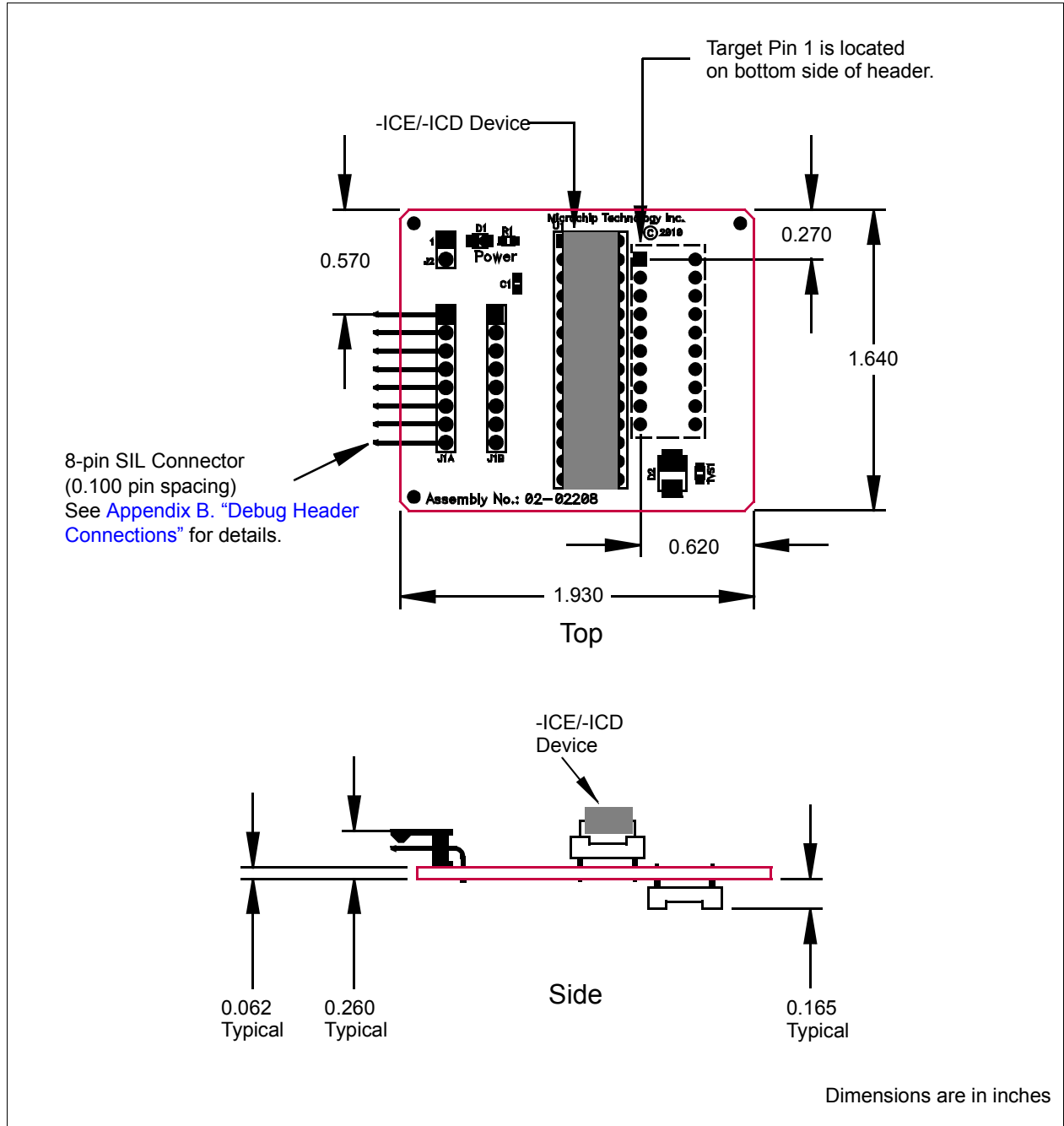

# PEP and Debug Header Specification

---

## AC244062

### Header Identification

The AC number is used for ordering the Processor Extension Pak, which contains the debug header. However, this number is not on the header, as the board may be used for multiple headers by inserting different -ICE/-ICD devices. To identify these headers, use the following information.

AC Number	-ICE/-ICD Device	Board Assembly Number
AC244062	PIC16F570-ICD	02-10229

### Header Setup and Operation

For these headers, there are no jumpers/switches. MPLAB X IDE will use its selected device to choose the correct device to emulate.

### Header Limitations

Sometimes a header device (-ICE/-ICD) has operational issues or errata. To determine if a device on a header has limitations, see your hardware tool documentation.



# Required Debug Headers

## Header Dimensions

The figure below lists the dimensions for the debug headers. Dimensions are design values in inches.

If the length and/or width of the debug header is too large a footprint for the target board, consider using stand-offs, transition sockets or other extenders in the header connection socket to raise the header above the target.

**FIGURE 2-14: DIMENSIONS - AC244062**

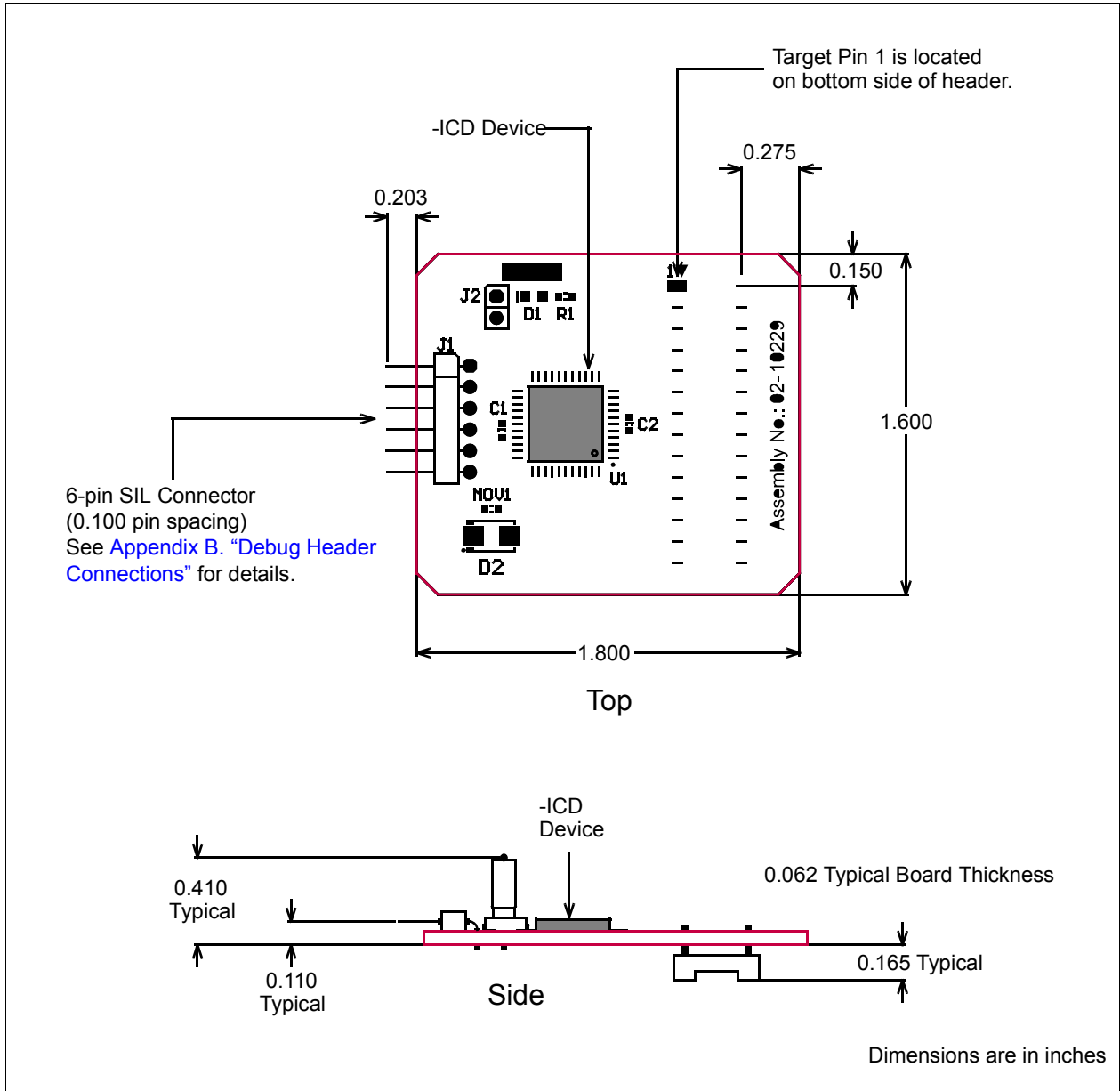

# PEP and Debug Header Specification

---

NOTES:

**Chapter 3. Optional Debug Headers**

**INTRODUCTION**

Devices that have built-in debug circuitry do not require a header to use debug tools. However, some pins and memory must be used to support the debug function. Special -ICE/-ICD versions offering additional pins, memory and emulator functions can be used to provide superior emulating/debugging capabilities.

Currently available debug headers and their associated -ICE/-ICD devices are shown below, sorted by supported device.

**TABLE 1: OPTIONAL DEBUG HEADERS - PIC12/16 DEVICES**

Device Supported by Debug Header	Pin Count	PEP* Part Number	-ICE/-ICD Device on Debug Header	V <sub>DD</sub> Max
PIC12F752	8	<a href="#">AC244049</a>	PIC12F752-ICE	5.5V
PIC12HV752	8	<a href="#">AC244050</a>	PIC12HV752-ICE	5.5V
PIC16F722 PIC16F723 PIC16F724 PIC16F726 PIC16F727	28 28 40/44 28 40/44	<a href="#">AC244026</a>	PIC16F727-ICE	5.5V
PIC16LF722 PIC16LF723 PIC16LF724 PIC16LF726 PIC16LF727	28 28 40/44 28 40/44	<a href="#">AC244027</a>	PIC16LF727-ICE	3.6V
PIC16F753 PIC16HV753	14/16 14/16	<a href="#">AC244060</a>	PIC16F753-ICE	5.5V
PIC16F1454 PIC16F1455 PIC16F1458 PIC16F1459	14/16 14/16 20 20	<a href="#">AC244053</a>	PIC16F1459-ICE	5.5V
PIC16LF1454 PIC16LF1455 PIC16LF1458 PIC16LF1459	14/16 14/16 20 20	<a href="#">AC244054</a>	PIC16LF1459-ICE	3.6V
PIC16F1508 <sup>(1)</sup> PIC16F1509 <sup>(1)</sup>	20	<a href="#">AC244051</a>	PIC16F1509-ICE	5.5V
PIC16LF1508 <sup>(1)</sup> PIC16LF1509 <sup>(1)</sup>	20	<a href="#">AC244052</a>	PIC16LF1509-ICE	3.6V

\* PEP = Processor Extension Pak.

**Note 1:** Header required for other devices, but optional for this device.

**Note 2:** VDDCORE Max

# PEP and Debug Header Specification

**TABLE 1: OPTIONAL DEBUG HEADERS - PIC12/16 DEVICES (CON'T)**

Device Supported by Debug Header	Pin Count	PEP* Part Number	-ICE/-ICD Device on Debug Header	VDD Max
PIC12F1822 PIC12F1840 PIC16F1823 PIC16F1824 PIC16F1825 PIC16F1829	8 8 14/16 14/16 14/16 20	AC244043	PIC16F1829-ICE	5.5V
PIC12LF1822 PIC12LF1840 PIC16LF1823 PIC16LF1824 PIC16LF1825 PIC16LF1829	8 8 14/16 14/16 14/16 20	AC244044	PIC16LF1829-ICE	3.6V
PIC16F1826 PIC16F1827 PIC16F1847	18/20/28	AC244046	PIC16F1847-ICE	5.5V
PIC16LF1826 PIC16LF1827 PIC16LF1847	18/20/28	AC244047	PIC16LF1847-ICE	3.6V
PIC16LF1902 PIC16LF1903 PIC16LF1904 PIC16LF1906 PIC16LF1907	28 28 40/44 28 40/44	AC224048	PIC16LF1907-ICE	3.6V
PIC16F1933 PIC16F1934 PIC16F1936 PIC16F1937 PIC16F1938 PIC16F1939	28 40/44 28 40/44 28 40/44	AC244035	PIC16F1939-ICE	5.5V
PIC16LF1933 PIC16LF1934 PIC16LF1936 PIC16LF1937 PIC16LF1938 PIC16LF1939	28 40/44 28 40/44 28 40/44	AC244036	PIC16LF1939-ICE	3.6V, 2.75V <sup>(2)</sup>

\* PEP = Processor Extension Pak.

**Note 1:** Header required for other devices, but optional for this device.

**Note 2:** VDDCORE Max

# Optional Debug Headers

**TABLE 2: OPTIONAL DEBUG HEADERS - PIC18 DEVICE**

Device Supported by Debug Header	Pin Count	PEP* Part Number	-ICE/-ICD Device on Debug Header	V <sub>DD</sub> Max
PIC18F1230/1330	28	<a href="#">AC162078</a>	PIC18F1330-ICD	5.5V
PIC18F13K22 PIC18F14K22	20	<a href="#">AC244033</a>	PIC18F14K22-ICE	5.5V
PIC18LF13K22 PIC18LF14K22	20	<a href="#">AC244034</a>	PIC18LF14K22-ICE	3.6V 2.75V <sup>(2)</sup>
PIC18F24J10 PIC18F25J10	28	<a href="#">AC162067</a>	PIC18F45J10-ICE	3.6V
PIC18LF24J10 PIC18LF25J10				3.6V 2.75V <sup>(2)</sup>
PIC18F44J10 PIC18F45J10	40			3.6V
PIC18LF44J10 PIC18LF45J10				3.6V 2.75V <sup>(2)</sup>
PIC18F44J10 PIC18F45J10	44	<a href="#">AC162074</a>	PIC18F45J10-ICE	3.6V
PIC18LF44J10 PIC18LF45J10				3.6V 2.75V <sup>(2)</sup>
PIC18F63J11 PIC18F63J90 PIC18F64J11 PIC18F64J16 PIC18F64J90 PIC18F64J95 PIC18F65J11 PIC18F65J90	64	<a href="#">AC162079</a>	PIC18F85J90-ICE	3.6V
PIC18F83J11 PIC18F83J90 PIC18F84J11 PIC18F84J16 PIC18F84J90 PIC18F84J95 PIC18F85J11 PIC18F85J90	80			
PIC18F65J10 PIC18F65J15 PIC18F66J10 PIC18F66J15 PIC18F67J10	64	<a href="#">AC162062</a>	PIC18F87J10-ICE	3.6V
PIC18F85J10 PIC18F85J15 PIC18F86J10 PIC18F86J15 PIC18F87J10	80			

\* PEP = Processor Extension Pak.

**Note 1:** Header required for other devices, but optional for this device.

**Note 2:** V<sub>DDCORE</sub> Max

# PEP and Debug Header Specification

**TABLE 2: OPTIONAL DEBUG HEADERS - PIC18 DEVICE (CON'T)**

Device Supported by Debug Header	Pin Count	PEP* Part Number	-ICE/-ICD Device on Debug Header	VDD Max
PIC18F65J16 PIC18F66J11 PIC18F66J16 PIC18F67J11	64	AC162091	PIC18F87J11-ICE	3.6V
PIC18F85J16 PIC18F86J11 PIC18F86J16 PIC18F87J11	80			
PIC18F65J50 PIC18F65J55 PIC18F66J50 PIC18F66J55 PIC18F67J50	64	AC162087	PIC18F87J50-ICE	3.6V
PIC18F85J50 PIC18F85J55 PIC18F86J50 PIC18F86J55 PIC18F87J50	80			
PIC18F66J60 PIC18F66J65 PIC18F67J60	64	AC162064	PIC18F97J60-ICE	3.6V
PIC18F86J60 PIC18F86J65 PIC18F87J60	80			
PIC18F96J60 PIC18F96J65 PIC18F97J60	100			

\* PEP = Processor Extension Pak.

**Note 1:** Header required for other devices, but optional for this device.

**Note 2:** VDDCORE Max

# Optional Debug Headers

**TABLE 3: OPTIONAL DEBUG HEADERS - PIC24 DEVICE**

Device Supported by Debug Header	Pin Count	PEP* Part Number	-ICE/-ICD Device on Debug Header	V <sub>DD</sub> Max
PIC24F08KA101 <sup>(1)</sup> PIC24F08KA102 <sup>(1)</sup> PIC24F16KA101 <sup>(1)</sup> PIC24F16KA102 <sup>(1)</sup>	20 20/28 20 20/28	AC244028	PIC24F16KA102-ICE	3.6V
PIC24FJ16GA002 PIC24FJ32GA002 PIC24FJ48GA002 PIC24FJ64GA002	28	AC162088	PIC24FJ64GA004-ICE	3.6V
PIC24FJ16GA004 PIC24FJ32GA004 PIC24FJ48GA004 PIC24FJ64GA004	44	AC162094		
PIC24FJ64GA006 PIC24FJ64GA008 PIC24FJ64GA010	64 80 100	AC162065 or AC244022	PIC24FJ128GA010-ICE	3.6V
PIC24FJ96GA006 PIC24FJ96GA008 PIC24FJ96GA010	64 80 100			
PIC24FJ128GA006 PIC24FJ128GA008 PIC24FJ128GA010	64 80 100			

\* PEP = Processor Extension Pak.

**Note 1:** Header required for other devices, but optional for this device.

**Note 2:** V<sub>DDCORE</sub> Max

# PEP and Debug Header Specification

## AC162062, AC162079, AC162087, AC162091

### Header Identification

The AC number is used for ordering the Processor Extension Pak, which contains the debug header. However, this number is not on the header, as the board may be used for multiple headers by inserting different -ICE/-ICD devices. To identify these headers, use the following information.

AC Number	-ICE/-ICD Device	Board Assembly Number
AC162062	PIC18F87J10-ICE	02-01830
AC162079	PIC18F85J90-ICE	
AC162087	PIC18F87J50-ICE	
AC162091	PIC18F87J11-ICE	

### Header Setup and Operation – AC162062

For this header, there are no jumpers/switches. MPLAB X IDE will use its selected device to choose the correct device to emulate.

Test points are available on this header to check the following: VDD, VDDCORE and ground.

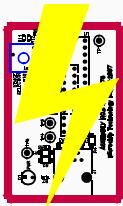
	<b>CAUTION</b>
	<b>Header damage.</b> This header cannot be plugged directly into the PICDEM™ HPC Explorer Board! Device damage will result.

The PICDEM™ HPC Explorer Board is 5V, whereas the ICD device on the header is 3.6V max. Therefore, modification to the demo board is necessary before the header can be used.

1. Switch S3 should be set to ICE.
2. Jumper J2 must be connected as shown in [Figure 3-1](#) to modify the operating voltage. See demo board documentation for more information.

**FIGURE 3-1: DEMO BOARD J2 CONNECTIONS**

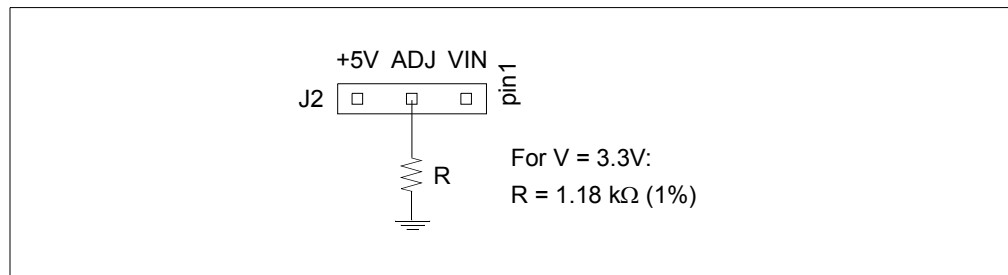

### Header Setup and Operation – AC162079, AC162087, AC162091

For these headers, there are no jumpers/switches. MPLAB X IDE will use its selected device to choose the correct device to emulate.

Test points are available on this header to check the following: VDD, VDDCORE and ground.



# Optional Debug Headers

## Header Limitations

Sometimes a header device (-ICE/-ICD) has operational issues or errata. To determine if a device on a header has limitations, see your hardware tool documentation.

## Header Dimensions

The figure below lists the dimensions for the debug header. Dimensions are design values in inches.

If the length and/or width of the debug header is too large a footprint for the target board, consider using stand-offs, transition sockets or other extenders in the header connection socket to raise the header above the target.

**FIGURE 3-2: DIMENSIONS – AC162062, AC162079, AC162087, AC162091**

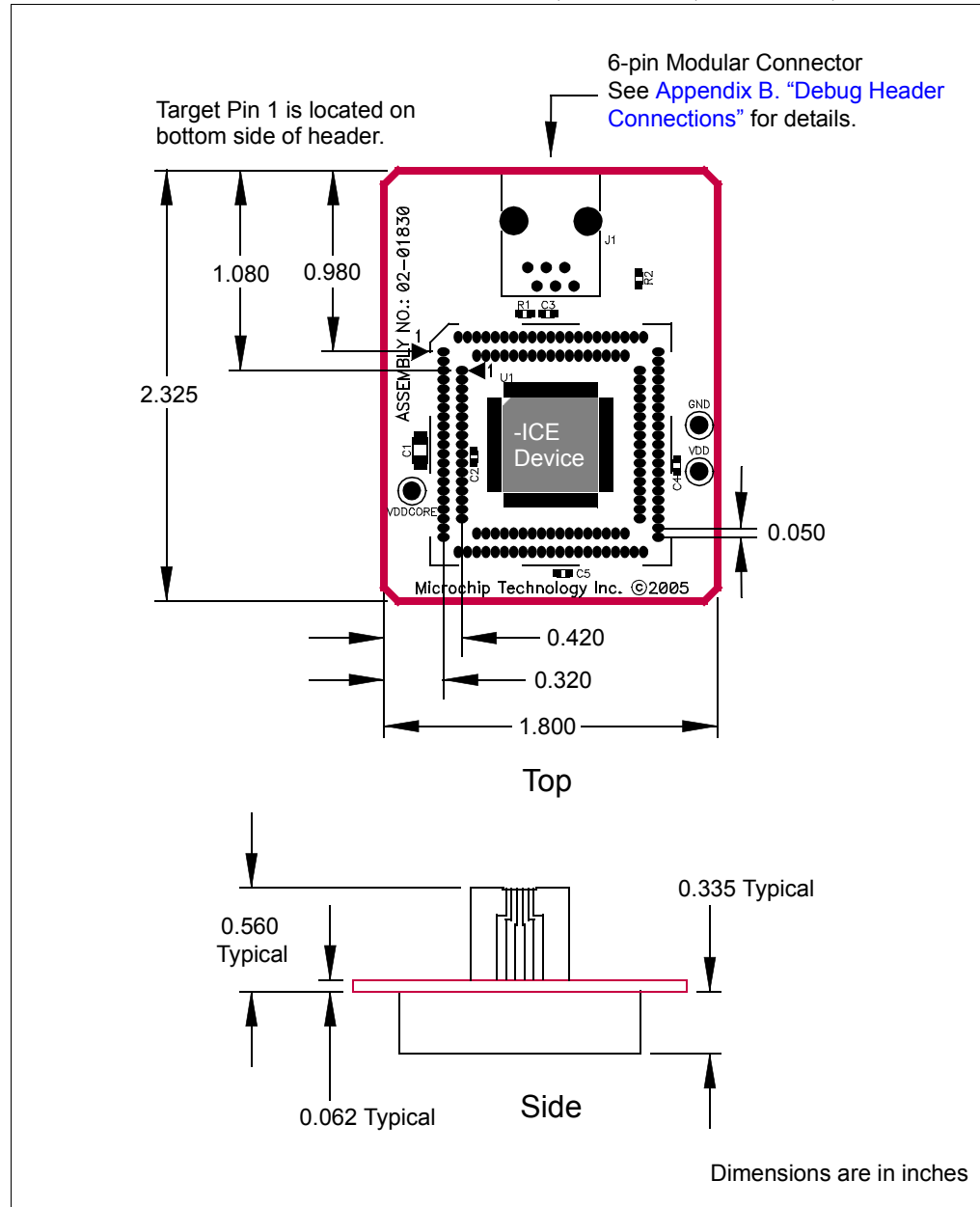

# PEP and Debug Header Specification

---

## AC162064

### Header Identification

The AC number is used for ordering the Processor Extension Pak, which contains the debug header. However, this number is not on the header, as the board may be used for multiple headers by inserting different -ICE/-ICD devices. To identify this header, use the following information.

AC Number	-ICE/-ICD Device	Board Assembly Number
AC162064	PIC18F97J60-ICE	02-01853

### Header Setup and Operation

For this header, there are no jumpers/switches. MPLAB X IDE will use its selected device to choose the correct device to emulate.

Test points are available on this header to check the following: VDD, VDDCORE and ground.

### Header Limitations

Sometimes a header device (-ICE/-ICD) has operational issues or errata. To determine if a device on a header has limitations, see your hardware tool documentation.

# Optional Debug Headers

## Header Dimensions

The figure below lists the dimensions for the debug header. Dimensions are design values in inches.

If the length and/or width of the debug header is too large a footprint for the target board, consider using stand-offs, transition sockets or other extenders in the header connection socket to raise the header above the target.

**FIGURE 3-3: DIMENSIONS – AC162064**

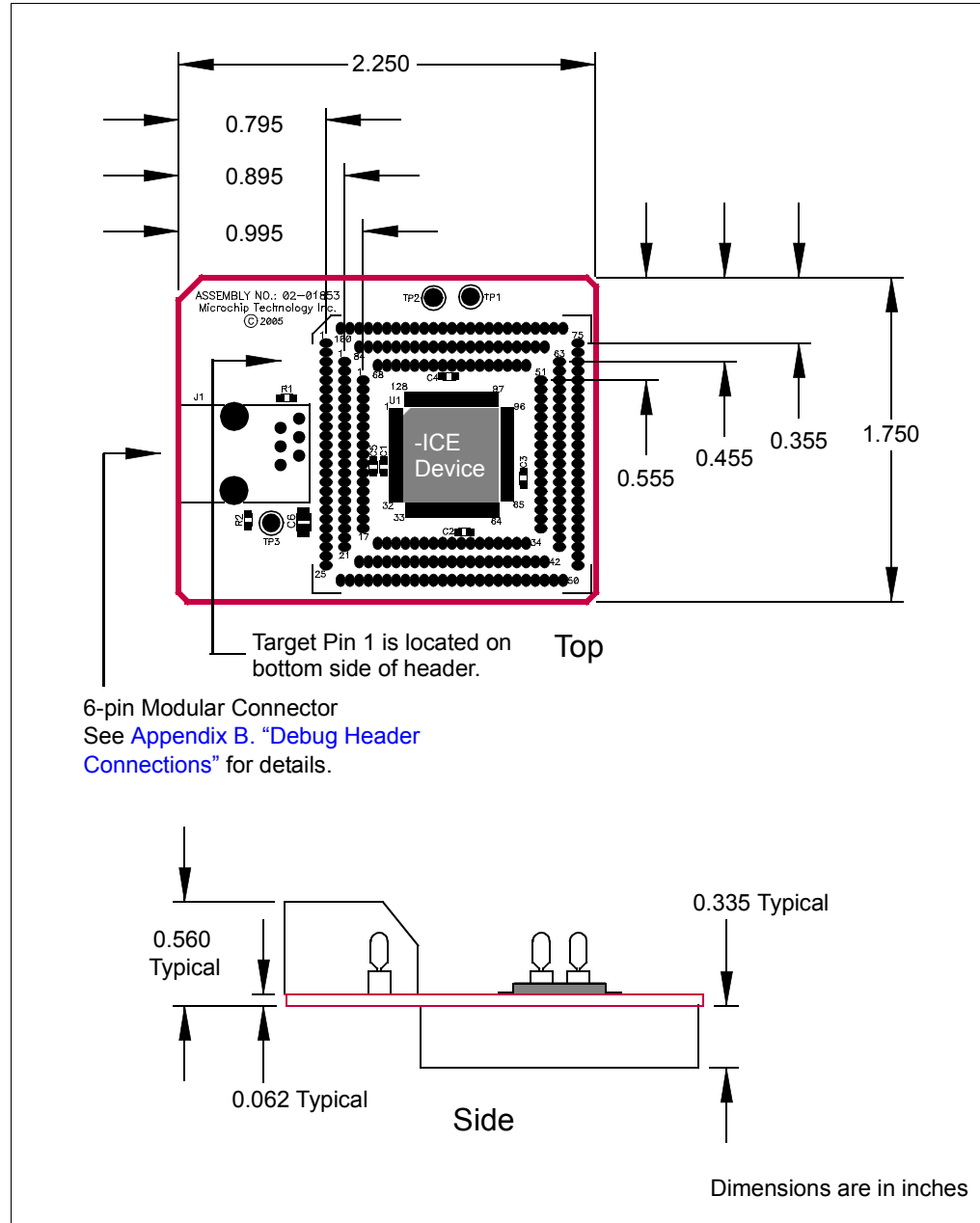

# PEP and Debug Header Specification

---

## AC162065, AC244022

### Header Identification

The AC number is used for ordering the Processor Extension Pak, which contains the debug header. However, this number is not on the header, as the board may be used for multiple headers by inserting different -ICE/-ICD devices. To identify these headers, use the following information.

AC Number	-ICE/-ICD Device	Board Assembly Number
AC162065	PIC24FJ128GA010-ICE	02-01856
AC244022		02-01985

### Header Setup and Operation

For this header, there are no jumpers/switches. MPLAB X IDE will use its selected device to choose the correct device to emulate.

Test points are available on this header to check the following: VDD, VDDCORE and ground.

### Header Limitations

Sometimes a header device (-ICE/-ICD) has operational issues or errata. To determine if a device on a header has limitations, see your hardware tool documentation.

### Header Dimensions

The following figures list the dimensions for the debug headers. Dimensions are design values in inches.

For this device family, header AC162065 will be sold until depleted. Then, only header AC244022 will remain as a Performance Pak.

If the length and/or width of the debug header is too large a footprint for the target board, consider using stand-offs, transition sockets or other extenders in the header connection socket to raise the header above the target.

# Optional Debug Headers

FIGURE 3-4: DIMENSIONS – AC162065

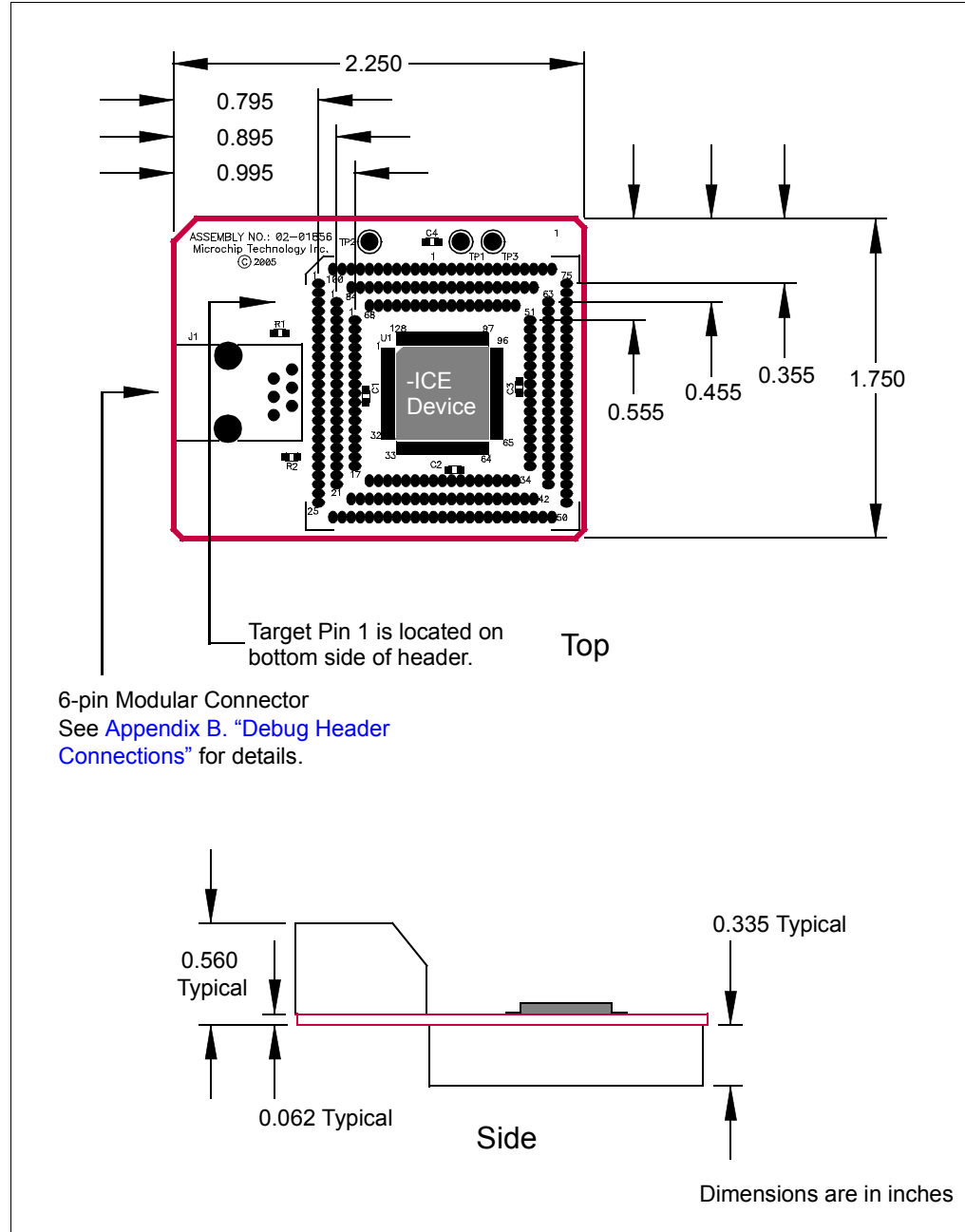

# PEP and Debug Header Specification

FIGURE 3-5: DIMENSIONS – AC244022

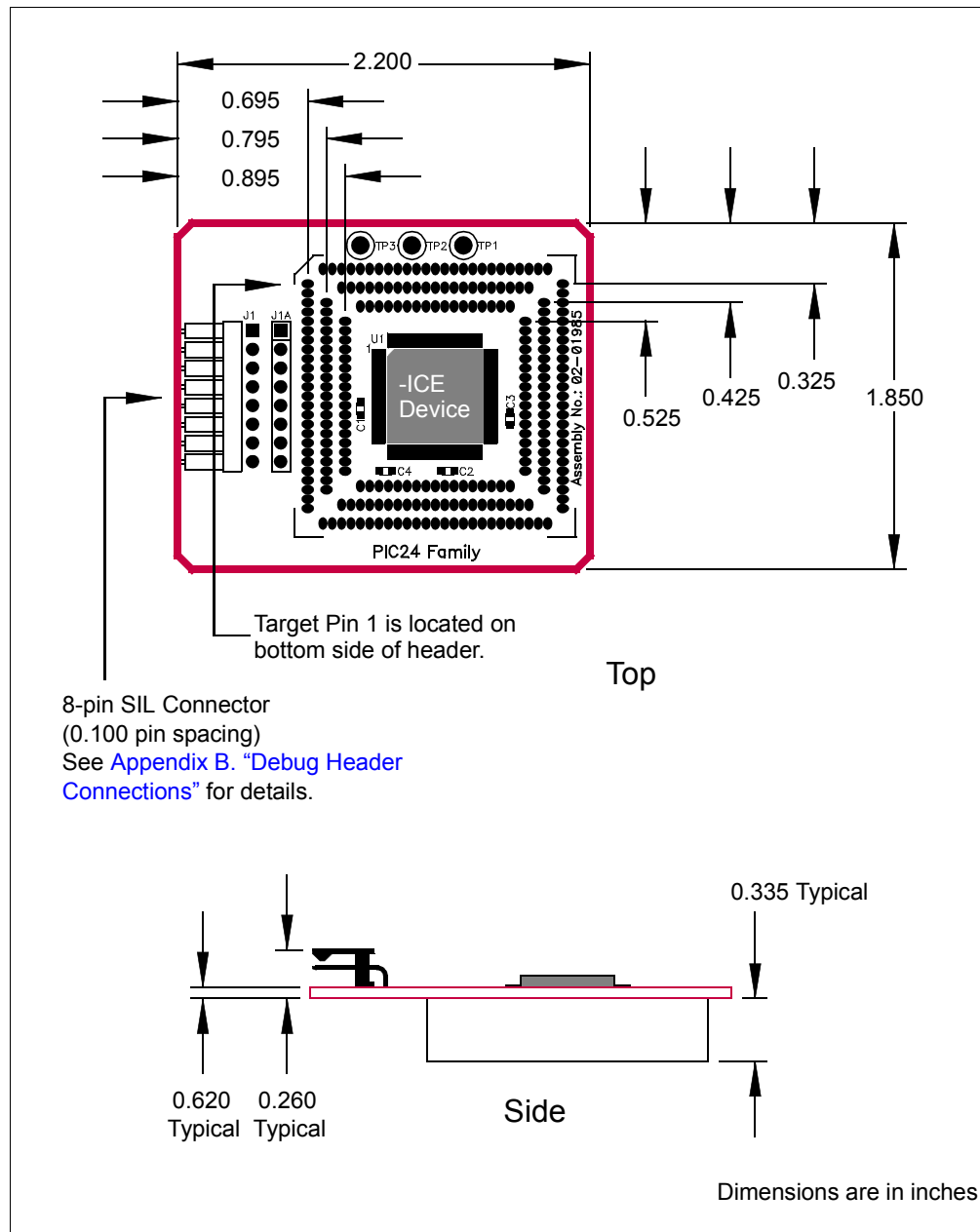

## AC162067, AC162074

### Header Identification

The AC number is used for ordering the Processor Extension Pak, which contains the debug header. However, this number is not on the header, as the board may be used for multiple headers by inserting different -ICE/-ICD devices. To identify these headers, use the following information.

AC Number	-ICE/-ICD Device	Board Assembly Number
AC162067	PIC18F45J10-ICE	02-01854
AC162074		02-01929

### Header Setup and Operation

For these headers, connect jumpers J2 and J3 to select between the LF and F versions of devices.

Device	Device Type	Jumper J2	Jumper J3	Function
PIC18LFXXJ10	LF	1-2	1-2	Disable voltage regulator*
PIC18FXXJ10	F	2-3	2-3	Enable voltage regulator

\* VDDCORE must be supplied externally.

### Header Limitations

Sometimes a header device (-ICE/-ICD) has operational issues or errata. To determine if a device on a header has limitations, see your hardware tool documentation.

### Header Dimensions

The figures below list the dimensions for the debug headers. Dimensions are design values in inches.

If the length and/or width of the debug header is too large a footprint for the target board, consider using stand-offs, transition sockets or other extenders in the header connection socket to raise the header above the target.

# PEP and Debug Header Specification

FIGURE 3-6: DIMENSIONS (28/40-PIN) – AC162067

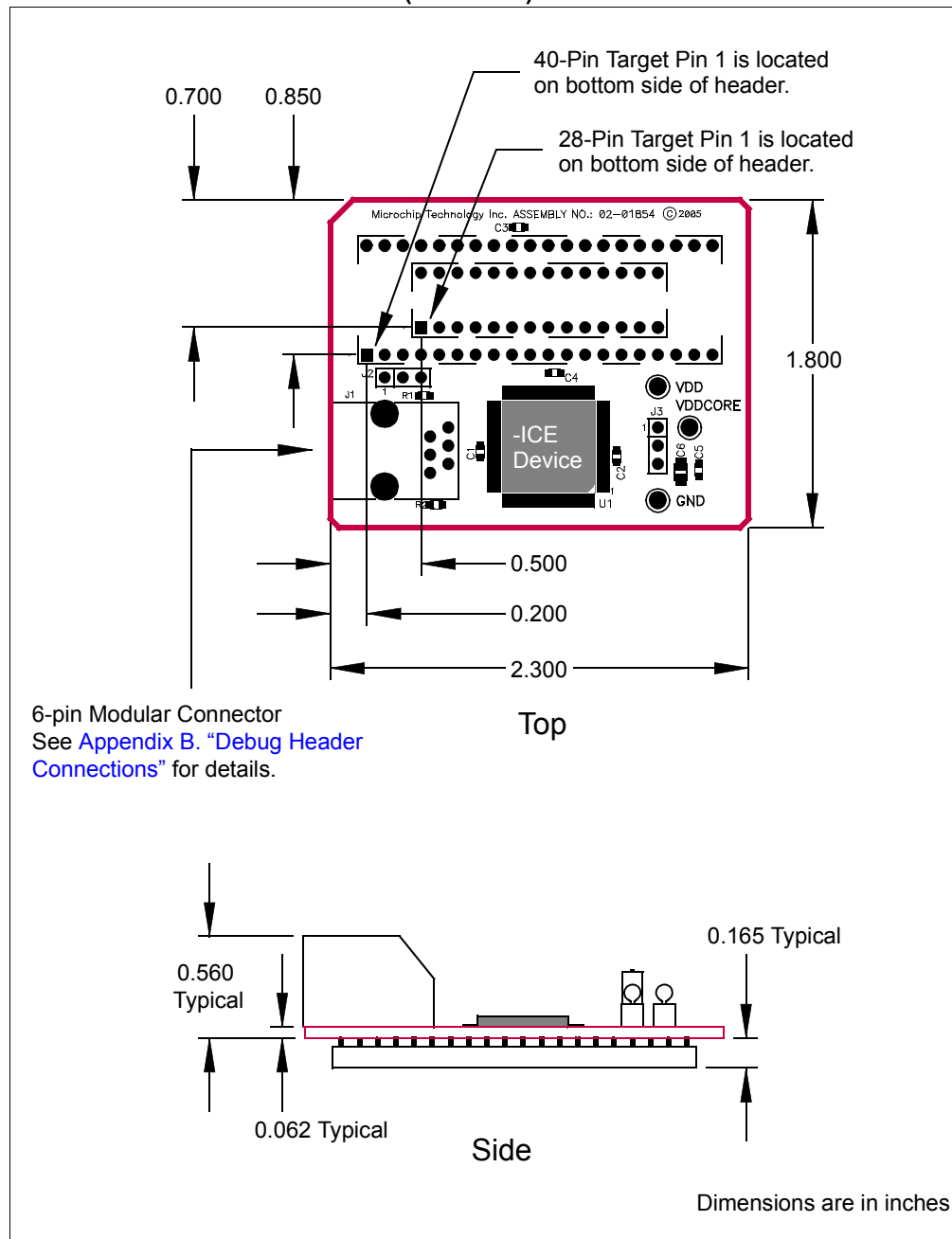



# Optional Debug Headers

FIGURE 3-7: DIMENSIONS (44-PIN) – AC162074

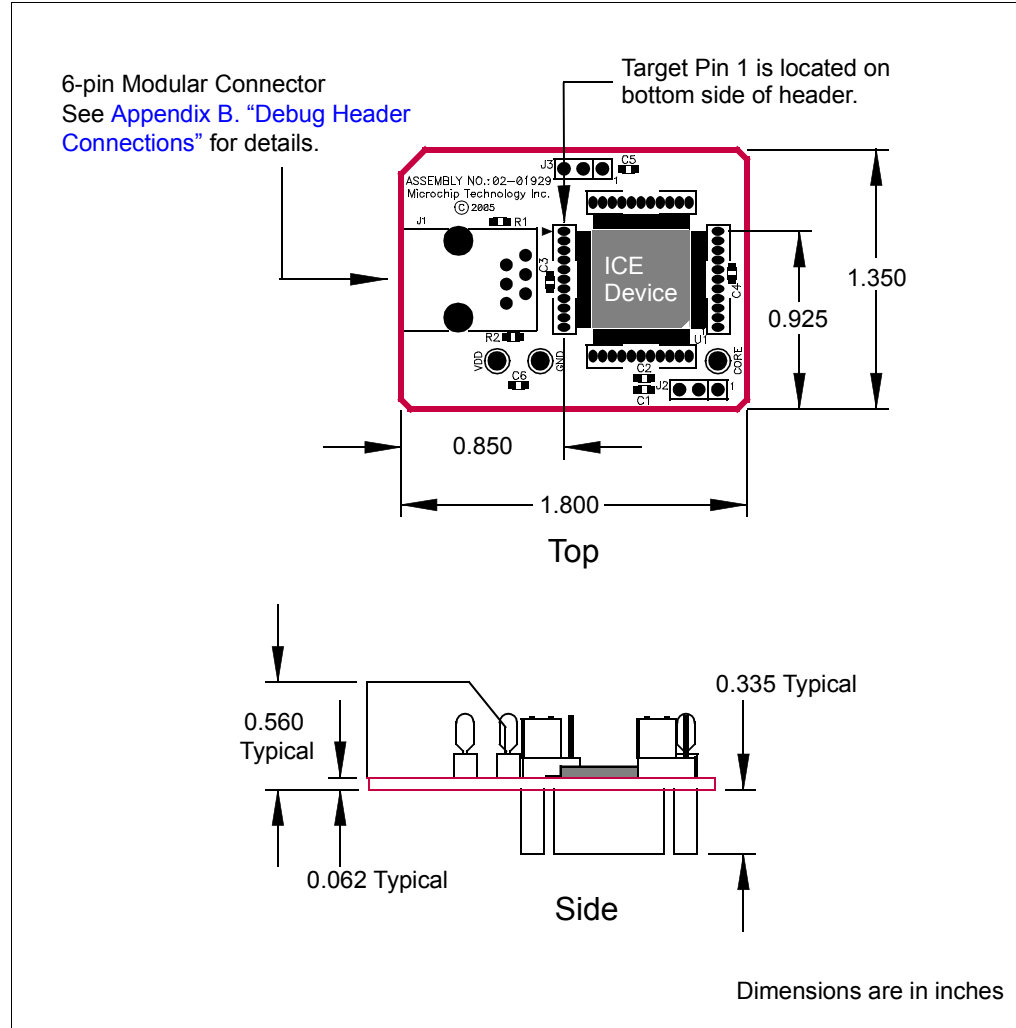

# PEP and Debug Header Specification

---

## AC162078

### Header Identification

The AC number is used for ordering the Processor Extension Pak, which contains the debug header. However, this number is not on the header, as the board may be used for multiple headers by inserting different -ICE/-ICD devices. To identify this header, use the following information.

AC Number	-ICE/-ICD Device	Board Assembly Number
AC162078	PIC18F1330-ICD	02-01896

### Header Setup and Operation

This debug header can be used with the following targets:

- Customer Target Board for PIC18F1230/1330 devices  
The target board should have an 18-pin DIP socket to connect to the 18-pin DIP socket on the debug header.
- PICDEM MC motor control demo board  
Use the 28-pin DIP socket on both boards to mount the debug header onto the PICDEM MC board.
- PICDEM MC LV motor control demo board  
Use the 28-pin DIP socket on both boards to mount the debug header onto the PICDEM MC LV board.

The following sections detail the configuration of the jumpers on the debug header for use with the above mentioned boards.

#### CUSTOMER TARGET BOARD

The default configuration is to remove all jumpers.

S1 is not populated and should not be used.

After the debug header is set up, do the following:

1. Connect the header to the target board.
2. Power the target board. You should see the red LED on the debug header turn on.
3. Connect the debug tool to the debug header.
4. Use MPLAB X IDE and the debug tool to develop your application.

#### PICDEM MC/MC LV MOTOR CONTROL DEMO BOARDS

To run a BLDC motor on the PICDEM MC board or PICDEM MC LV board using the supplied firmware, use the following jumper setup:

Jumper	Jumper Setting	Jumper	Jumper Setting
J1	2-3	JP1	Open
J2	2-3		
J3	2-3		
J5	2-3	JP2	Open
J6	1-2		
J7	1-2	JP3	Open

S1 is not populated and should not be used.

After the debug header is set up, perform the following steps:

1. Connect the header to the PICDEM MC/MC LV target board.
2. Power the target board. You should see the red LED on the debug header turn on.
3. Connect the debug tool to the debug header.
4. Program the part with the demo code.
5. Run the program.
6. Press and release switch S2 on the target board to toggle the direction of the motor's rotation.
7. Press and release switch S1 on the target board to toggle between running and stopping the motor.
8. If the motor stops while reversing from a high speed, there could be an overcurrent condition detected by the system. Reset the system to run the program again.

## Header Limitations

Sometimes a header device (-ICE/-ICD) has operational issues or errata. To determine if a device on a header has limitations, see your hardware tool documentation.

# PEP and Debug Header Specification

## Header Dimensions

The figure below lists the dimensions for the debug header. Dimensions are design values in inches.

If the length and/or width of the debug header is too large a footprint for the target board, consider using stand-offs, transition sockets or other extenders in the header connection socket to raise the header above the target.

**FIGURE 3-8: DIMENSIONS – AC162078**

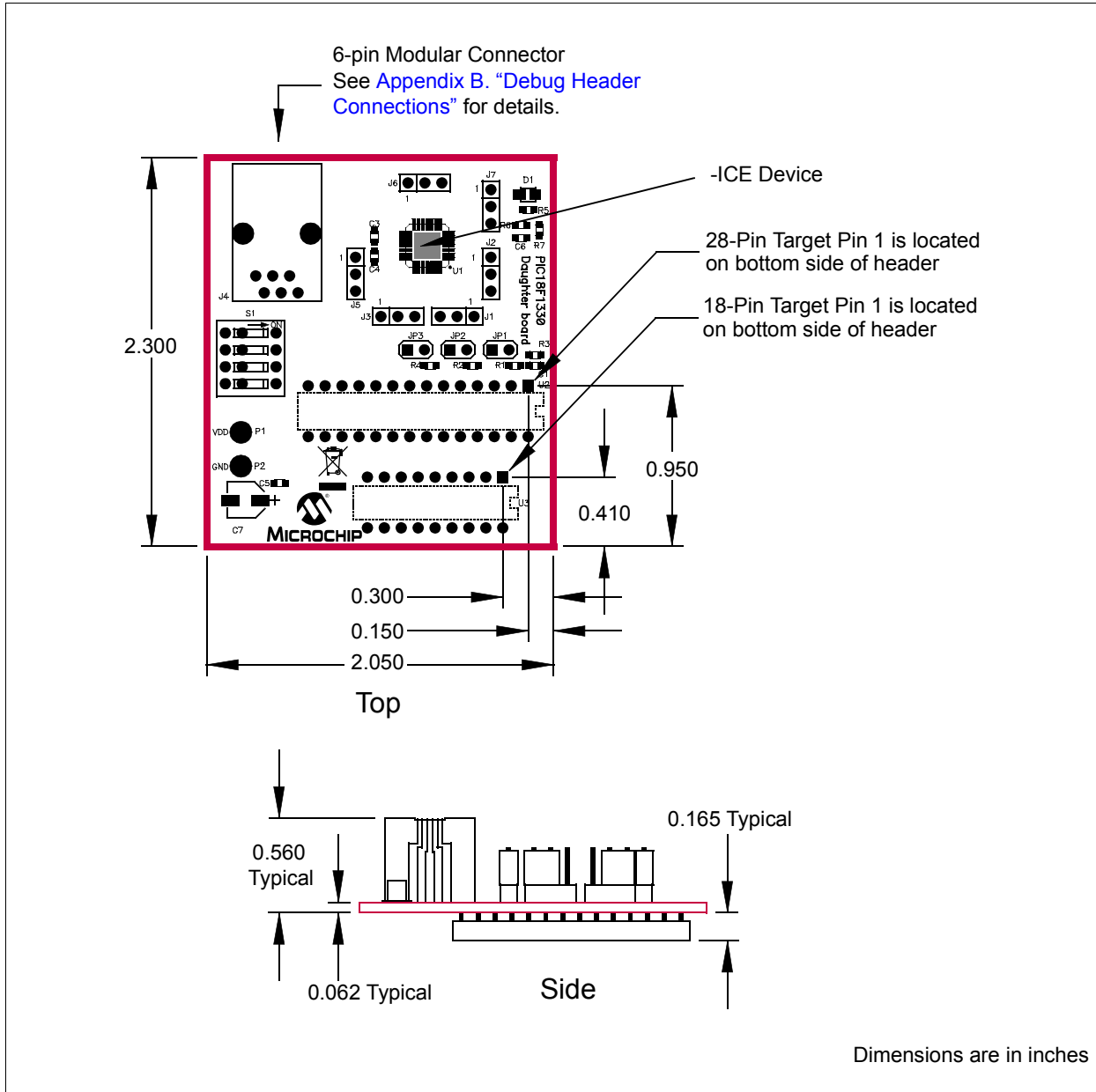

# Optional Debug Headers

## AC162088, AC162094

### Header Identification

The AC number is used for ordering the Processor Extension Pak, which contains the debug header. However, this number is not on the header, as the board may be used for multiple headers by inserting different -ICE/-ICD devices. To identify these headers, use the following information.

AC Number	-ICE/-ICD Device	Board Assembly Number
AC162088	PIC24FJ64GA004-ICE	02-01979
AC162094		02-01982

### Header Setup and Operation

Both 28-pin and 44-pin device headers have jumpers related to the enabling or disabling of the on-chip 2.5 volt voltage regulator. Please see the section entitled “On-Chip Voltage Regulator” in the *dsPIC33F Family Reference Manual* (DS70165) for more details.

Jumper J2	Function
1-2	Disable voltage regulator
2-3	Enable voltage regulator
No connection	DISVREG controlled by target

Test points are available on this header to check the following:

Test Point	Color	Signal	Test Point	Color	Signal
TP1	Black	Ground	TP5	White	DISVREG
TP2	Red	VDD	TP6	White	PGC
TP3	Black	AVss	TP7	White	PGD
TP4	Red	AVDD	TP8	Yellow	$\overline{\text{ICRST}}$

### Header Limitations

Sometimes a header device (-ICE/-ICD) has operational issues or errata. To determine whether a device on a header has limitations, see your hardware tool documentation.

### Header Dimensions

The following figures list the dimensions for the debug headers. Dimensions are design values in inches.

If the length and/or width of the debug header is too large a footprint for the target board, consider using stand-offs, transition sockets or other extenders in the header connection socket to raise the header above the target.

# PEP and Debug Header Specification

FIGURE 3-9: DIMENSIONS (28 PIN) – AC162088

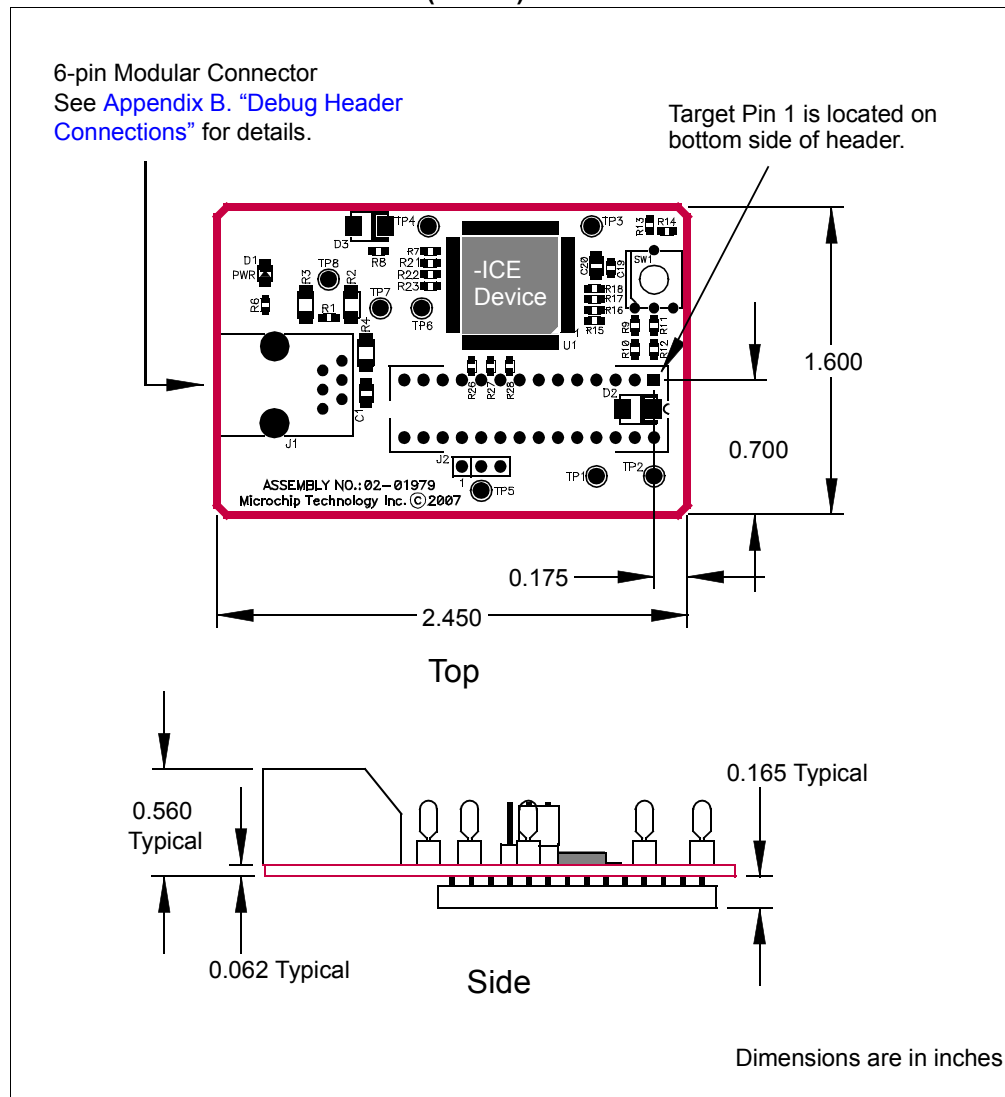

# Optional Debug Headers

FIGURE 3-10: DIMENSIONS (44 PIN) – AC162094

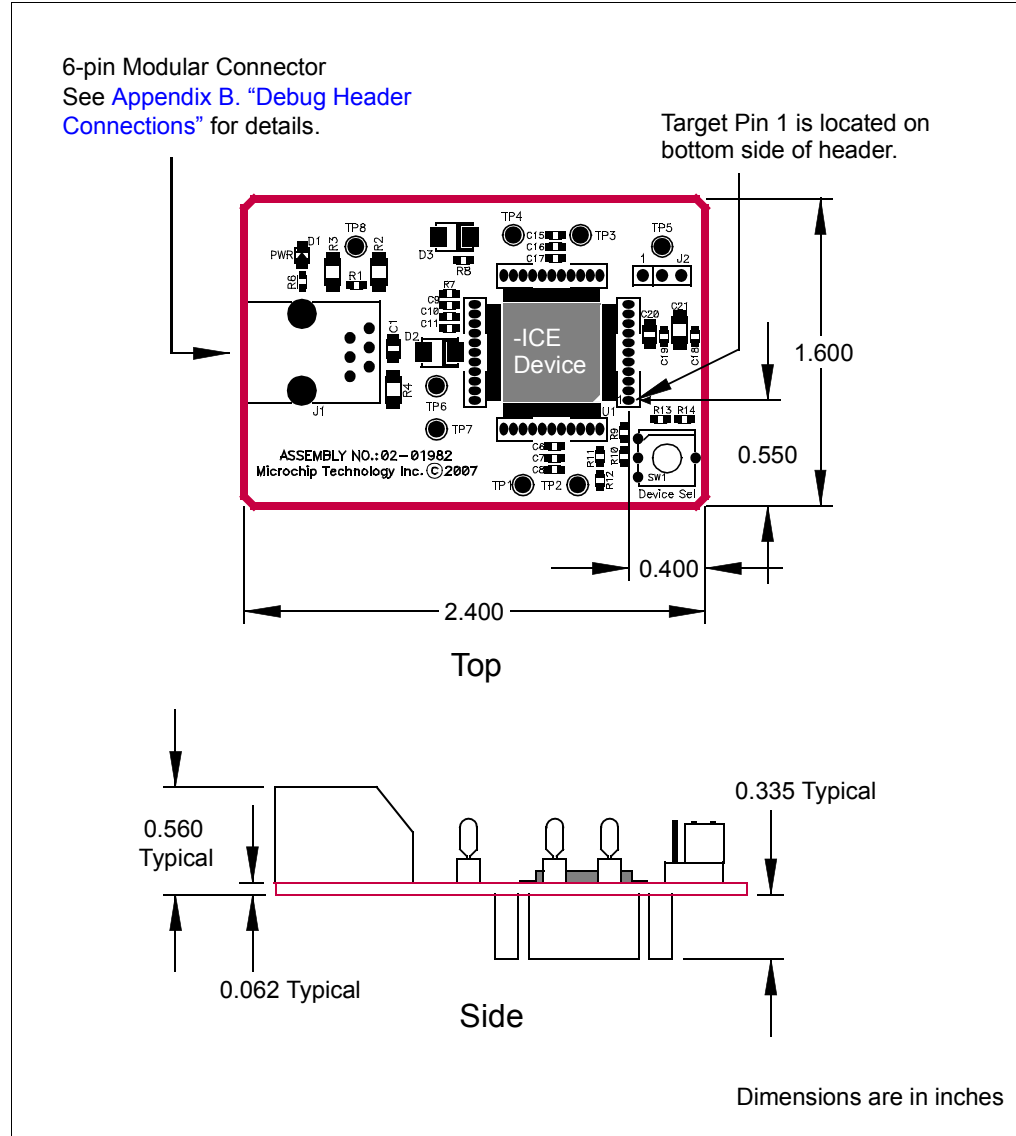

# PEP and Debug Header Specification

## AC244026, AC244027

### Header Identification

The AC number is used for ordering the Processor Extension Pak, which contains the debug header. However, this number is not on the header, as the board may be used for multiple headers by inserting different -ICE/-ICD devices. To identify these headers, use the following information.

AC Number	-ICE/-ICD Device	Board Assembly Number
AC244026	PIC16F727-ICE	02-02105
AC244027	PIC16LF727-ICE	

### Header Setup and Operation

This Processor Extension Pak provides extra debugging capability that is not available on the production devices, including the following:

- 3 Address/Data breakpoints (1 Address only breakpoint on production devices)
- Data capture (Real Time Data Streaming)
- No user Flash resources needed for debugging
- No user RAM resources needed for debugging
- No user pins required

This header has jumpers available for MCLR pull-up and power LED control.

Jumper	Setting	Function
J2	Open	Disable weak ICE MCLR pull-up resistor.
	Short	Enable weak ICE MCLR pull-up resistor. This option keeps the target program running even after the tool has been disconnected from the header, i.e., the pin will not float high.
J3	Open	Disable power LED indicator. This option saves power.
	Short	Enable power LED indicator.

### AC244026 HEADER

Additionally, this header has jumpers related to the LDO voltage regulator. Depending on the device pin used for this function, you would use either J4 (RA0), J5 (RA5) or J6 (RA6) for Vcap selection. For details on the voltage regulator, see the *PIC16F72X/PIC16LF72X Data Sheet* (DS41341).

Jumper	Setting	Function
J4, J5, or J6	Open	Use only target capacitance for Vcap. This is the standard configuration.
	Short	Use both on-board and target capacitance for Vcap. This option is to provide extra margin for the voltage regulator stability/regulation in cases where there is a long lead length between the emulation header Vcap pin and the target Vcap pin. (As examples, when using long-pin DIP transition sockets or certain QFN transition sockets.)



# Optional Debug Headers

---

Test points are available on this header to check the following:

Test Point	Signal	Test Point	Signal	Pin	Jumper
TP1	V <sub>SS</sub>	TP6	V <sub>cap</sub>	RA0	J4
TP2	V <sub>DD</sub>	TP7	V <sub>cap</sub>	RA5	J5
TP3	$\overline{\text{ICD Enable}}$	TP8	V <sub>cap</sub>	RA6	J6
TP4	V <sub>DD</sub>				
TP5	V <sub>SS</sub>				

## AC244027 HEADER

Test points are available on this header to check the following:

Test Point	Signal
TP1	V <sub>SS</sub>
TP2	V <sub>DD</sub>
TP3	$\overline{\text{ICD Enable}}$
TP4	V <sub>DD</sub>
TP5	V <sub>SS</sub>

## Header Limitations

Sometimes a header device (-ICE/-ICD) has operational issues or errata. To determine if a device on a header has limitations, see your hardware tool documentation.

## Header Dimensions

The following figure lists the dimensions for the debug headers. Dimensions are design values in inches.

If the length and/or width of the debug header is too large a footprint for the target board, consider using stand-offs, transition sockets or other extenders in the header connection socket to raise the header above the target.

# PEP and Debug Header Specification

FIGURE 3-11: DIMENSIONS – AC244026, AC244027

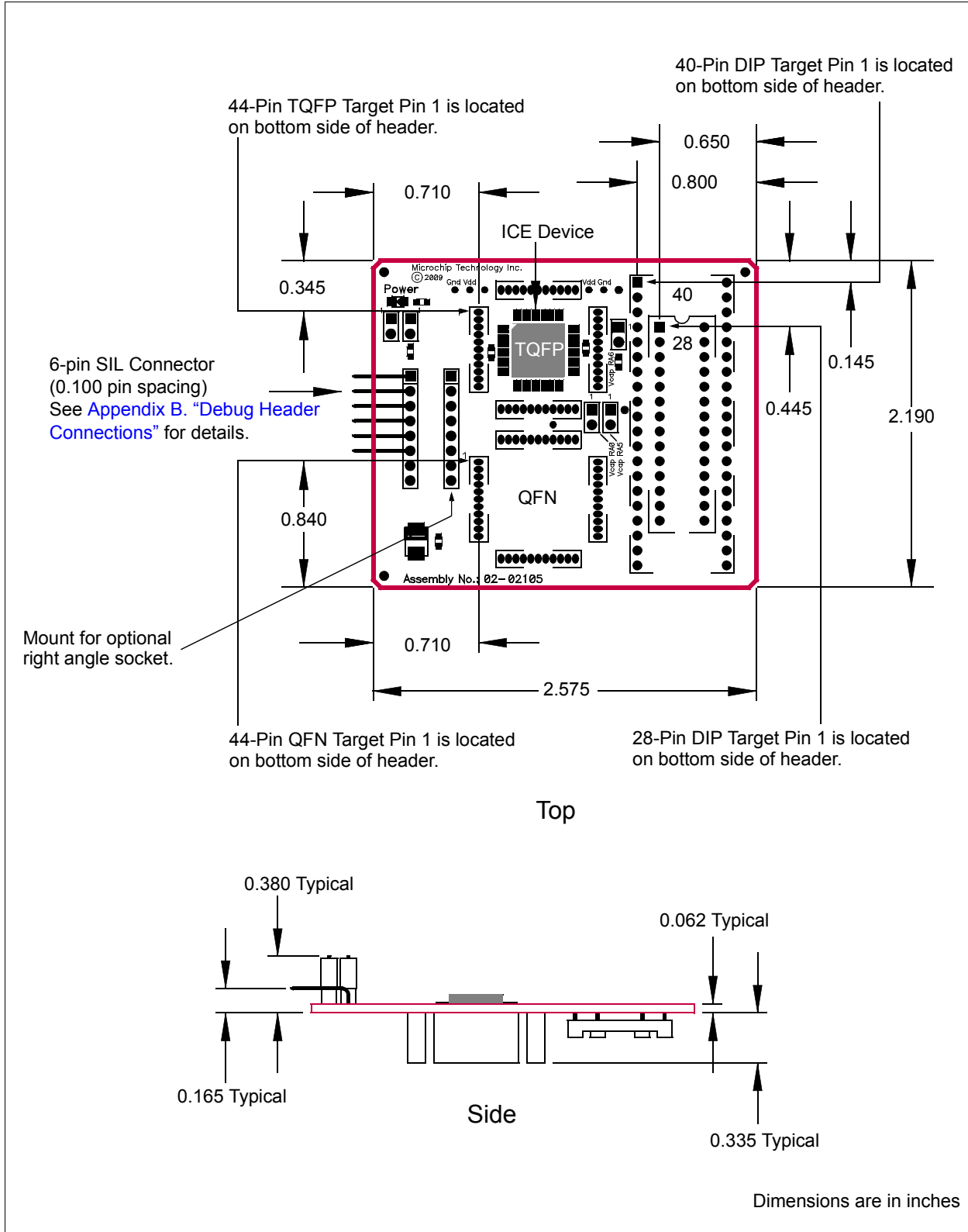

## AC244033, AC244034

### Header Identification

The AC number is used for ordering the Processor Extension Pak, which contains the debug header. However, this number is not on the header, as the board may be used for multiple headers by inserting different -ICE/-ICD devices. To identify these headers, use the following information.

AC Number	-ICE/-ICD Device	Board Assembly Number
AC244033	PIC18F14K22-ICE	02-02031
AC244034	PIC18LF14K22-ICE	

### Header Setup and Operation

For this header, there are no jumpers/switches. MPLAB X IDE will use its selected device to choose the correct device to emulate.

### Header Limitations

Sometimes a header device (-ICE/-ICD) has operational issues or errata. To determine if a device on a header has limitations, see your hardware tool documentation.

# PEP and Debug Header Specification

## Header Dimensions

The figure below lists the dimensions for the debug headers. Dimensions are design values in inches.

If the length and/or width of the debug header is too large a footprint for the target board, consider using stand-offs, transition sockets or other extenders in the header connection socket to raise the header above the target.

**FIGURE 3-12: DIMENSIONS (20 PIN) – AC244033, AC244034**

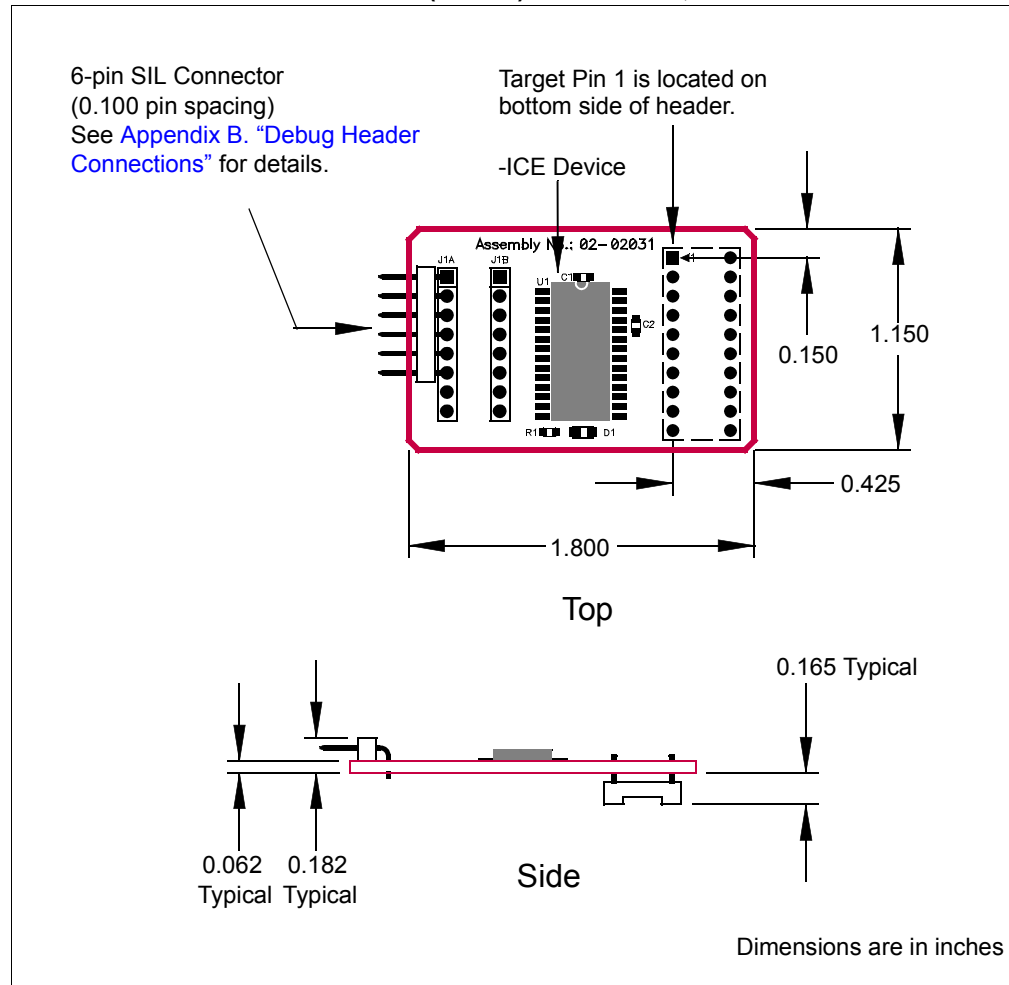

## AC244035, AC244036

### Header Identification

The AC number is used for ordering the Processor Extension Pak, which contains the debug header. However, this number is not on the header, as the board may be used for multiple headers by inserting different -ICE/-ICD devices. To identify these headers, use the following information.

AC Number	-ICE/-ICD Device	Board Assembly Number
AC244035	PIC16F1939-ICE	02-02105
AC244036	PIC16LF1939-ICE	

### Header Setup and Operation

For this header, set up the jumpers as described below.

Jumper	Setting	Function
J2	Open	Disable weak ICE/MCLR pull-up resistor
	Short	Enable weak ICE/MCLR pull-up resistor
J3	Open	Disable power LED indicator
	Short	Enable power LED indicator
J4	Open	Use only target capacitance for VCAP (on RA0 pin)
	Short	Use both on-board and target capacitance for VCAP (on RA0 pin)
J5	Open	Use only target capacitance for VCAP (on RA5 pin)
	Short	Use both on-board and target capacitance for VCAP (on RA5 pin)
J6	Open	Use only target capacitance for VCAP (on RA6 pin)
	Short	Use both on-board and target capacitance for VCAP (on RA6 pin)

### Header Limitations

Sometimes a header device (-ICE/-ICD) has operational issues or errata. To determine if a device on a header has limitations, see your hardware tool documentation.

# PEP and Debug Header Specification

## Header Dimensions

The figure below lists the dimensions for the debug header. Dimensions are design values in inches.

If the length and/or width of the debug header is too large a footprint for the target board, consider using stand-offs, transition sockets or other extenders in the header connection socket to raise the header above the target.

**FIGURE 3-13: DIMENSIONS - AC244035, AC244036**

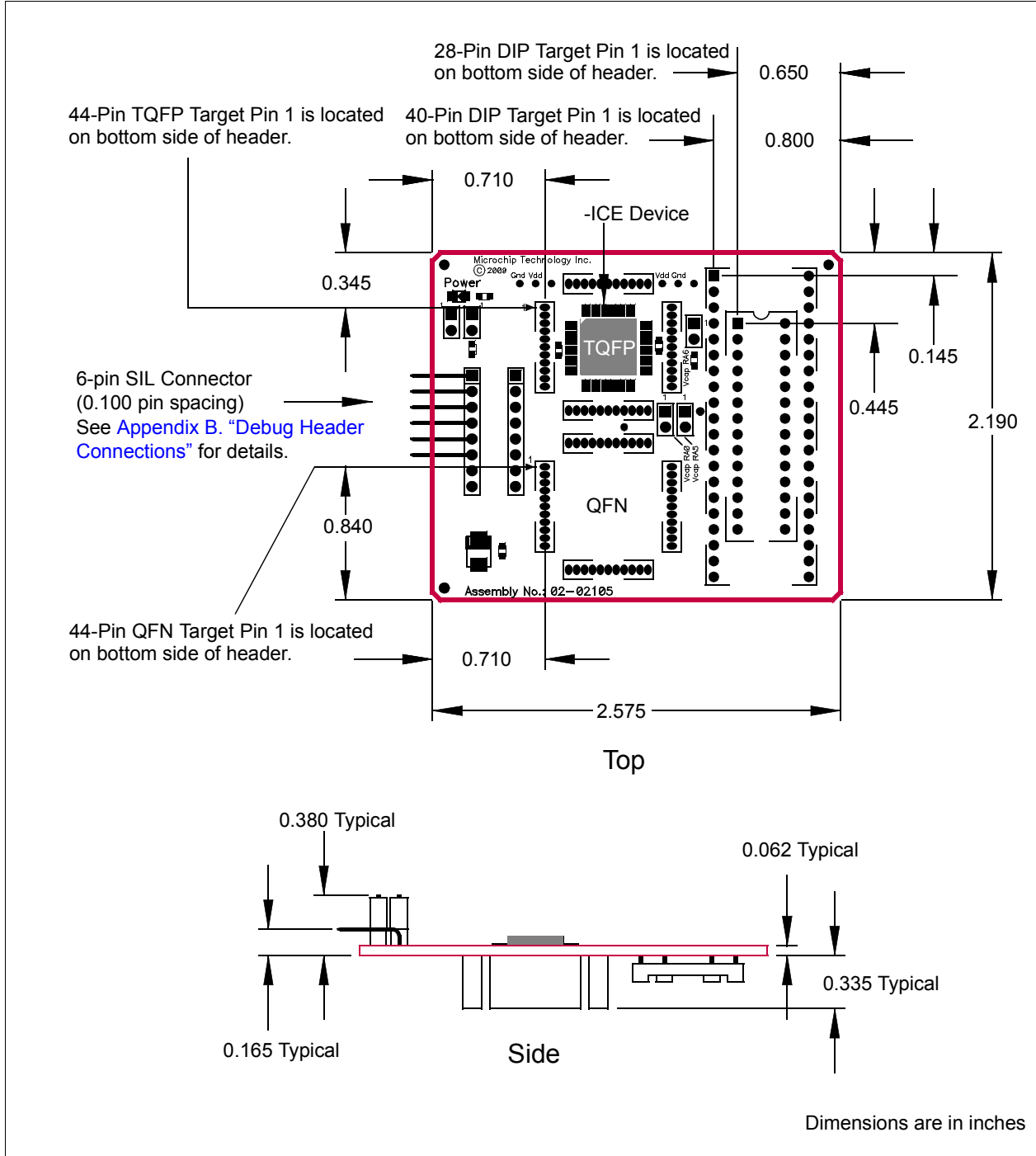

## AC244043, AC244044

### Header Identification

The AC number is used for ordering the Processor Extension Pak, which contains the debug header. However, this number is not on the header, as the board may be used for multiple headers by inserting different -ICE/-ICD devices. To identify these headers, use the following information.

AC Number	-ICE/-ICD Device	Board Assembly Number
AC244043	PIC16F1829-ICE	02-02208
AC244044	PIC16LF1829-ICE	

### Header Setup and Operation

For this header, there are no jumpers/switches. MPLAB X IDE will use its selected device to choose the correct device to emulate.

### Header Limitations

Sometimes a header device (-ICE/-ICD) has operational issues or errata. To determine if a device on a header has limitations, see your hardware tool documentation.

# PEP and Debug Header Specification

## Header Dimensions

The figure below lists the dimensions for the debug header. Dimensions are design values in inches.

If the length and/or width of the debug header is too large a footprint for the target board, consider using stand-offs, transition sockets or other extenders in the header connection socket to raise the header above the target.

**FIGURE 3-14: DIMENSIONS - AC244043, AC244044**

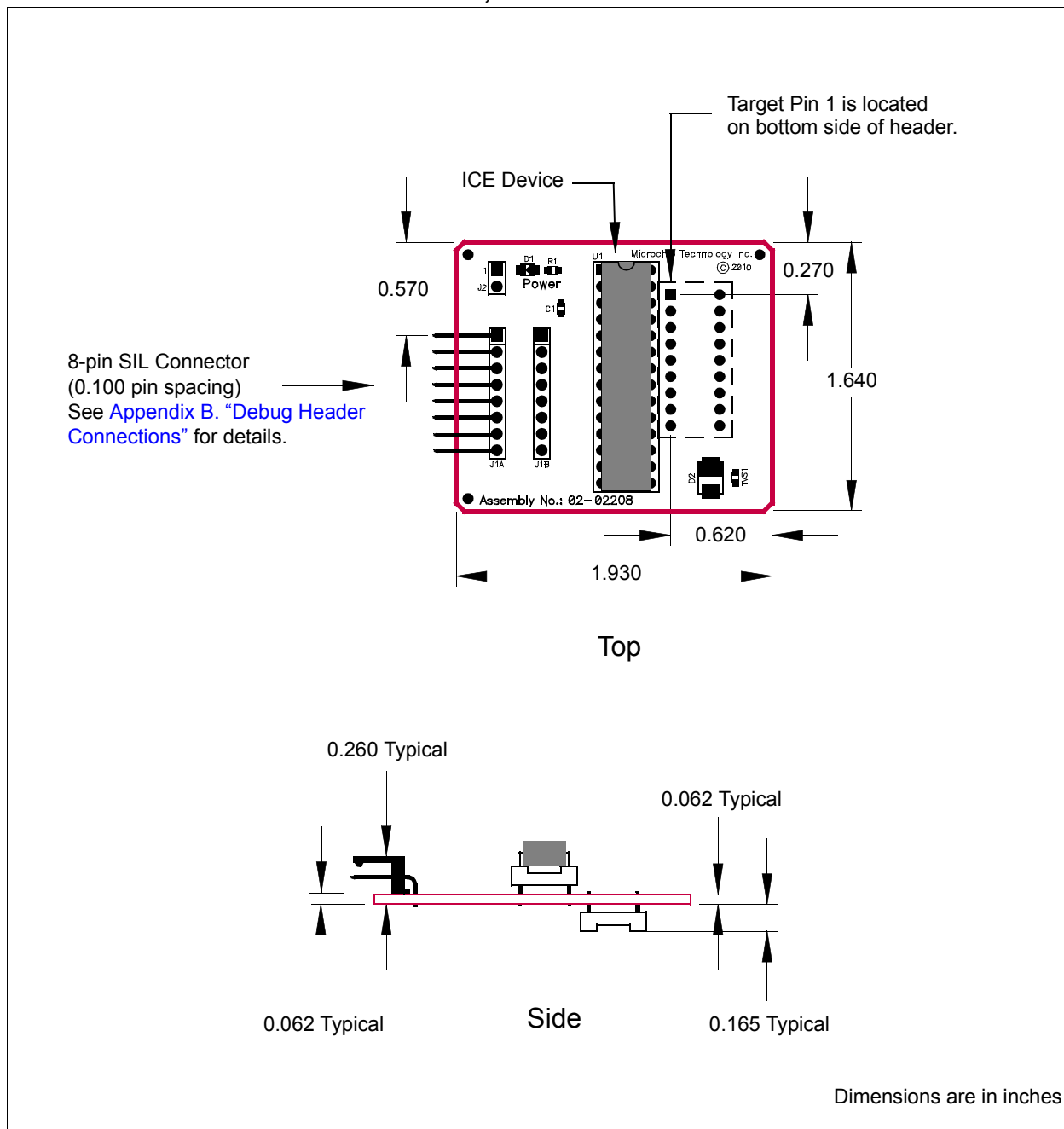



## AC244046, AC244047

### Header Identification

The AC number is used for ordering the Processor Extension Pak, which contains the debug header. However, this number is not on the header, as the board may be used for multiple headers by inserting different -ICE/-ICD devices. To identify these headers, use the following information.

AC Number	-ICE/-ICD Device	Board Assembly Number
AC244046	PIC16F1847-ICE	02-02258
AC244047	PIC16LF1847-ICE	

### Header Setup and Operation

For this header, there are no jumpers/switches. MPLAB X IDE will use its selected device to choose the correct device to emulate.

### Header Limitations

Sometimes a header device (-ICE/-ICD) has operational issues or errata. To determine if a device on a header has limitations, see your hardware tool documentation.

# PEP and Debug Header Specification

## Header Dimensions

The figure below lists the dimensions for the debug header. Dimensions are design values in inches.

If the length and/or width of the debug header is too large a footprint for the target board, consider using stand-offs, transition sockets or other extenders in the header connection socket to raise the header above the target.

**FIGURE 3-15: DIMENSIONS - AC244046, AC244047**

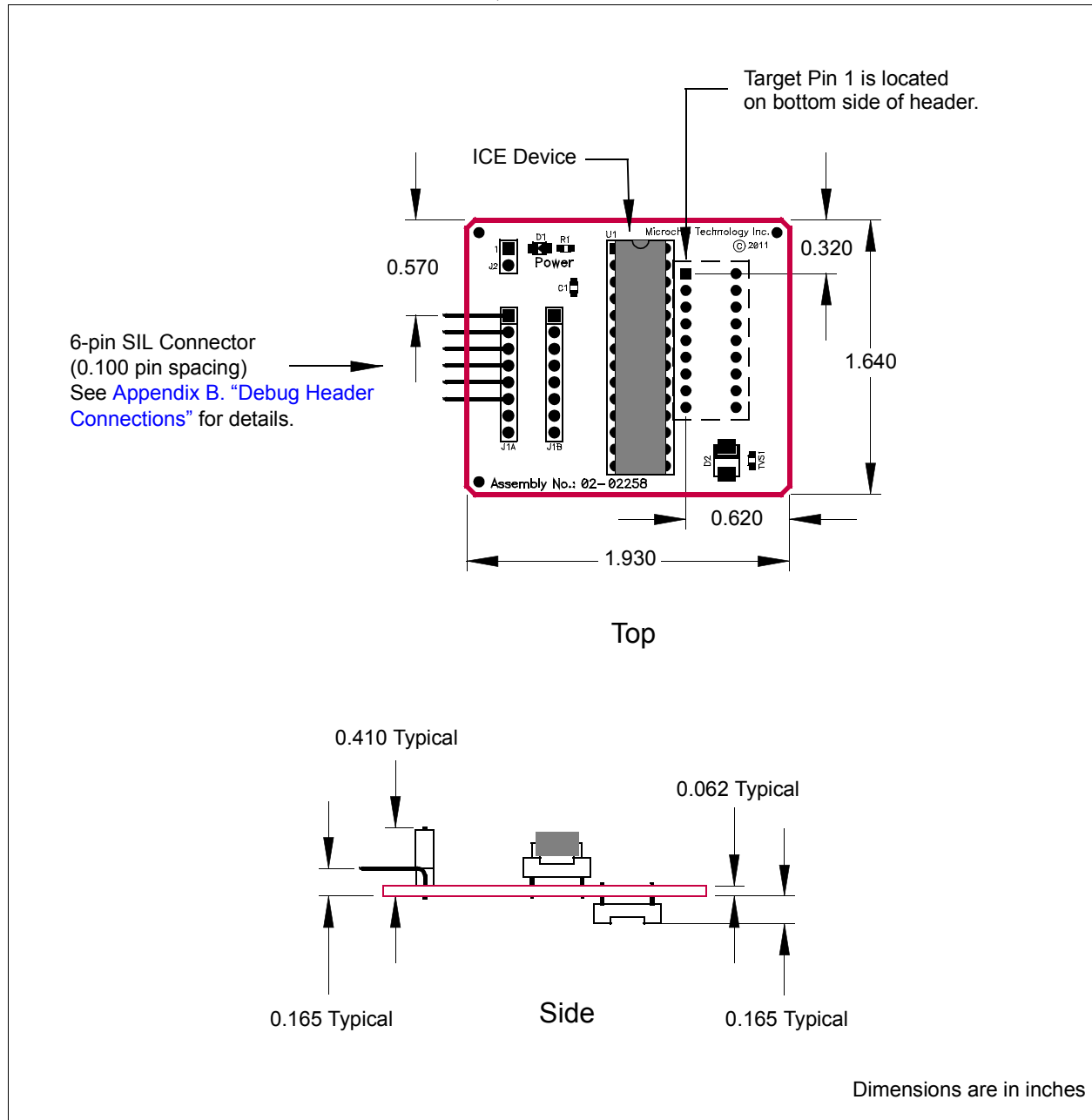

## AC244048

### Header Identification

The AC number is used for ordering the Processor Extension Pak, which contains the debug header. However, this number is not on the header, as the board may be used for multiple headers by inserting different -ICE/-ICD devices. To identify this header, use the following information.

AC Number	-ICE/-ICD Device	Board Assembly Number
AC244048	PIC16LF1907-ICE	02-02105

### Header Setup and Operation

For these headers, there are no jumpers/switches. MPLAB X IDE will use its selected device to choose the correct device to emulate.

### Header Limitations

Sometimes a header device (-ICE/-ICD) has operational issues or errata. To determine if a device on a header has limitations, see your hardware tool documentation.

### Header Dimensions

The following figure lists the dimensions for the debug headers. Dimensions are design values in inches.

If the length and/or width of the debug header is too large a footprint for the target board, consider using stand-offs, transition sockets or other extenders in the header connection socket to raise the header above the target.

# PEP and Debug Header Specification

FIGURE 3-16: DIMENSIONS - AC244048

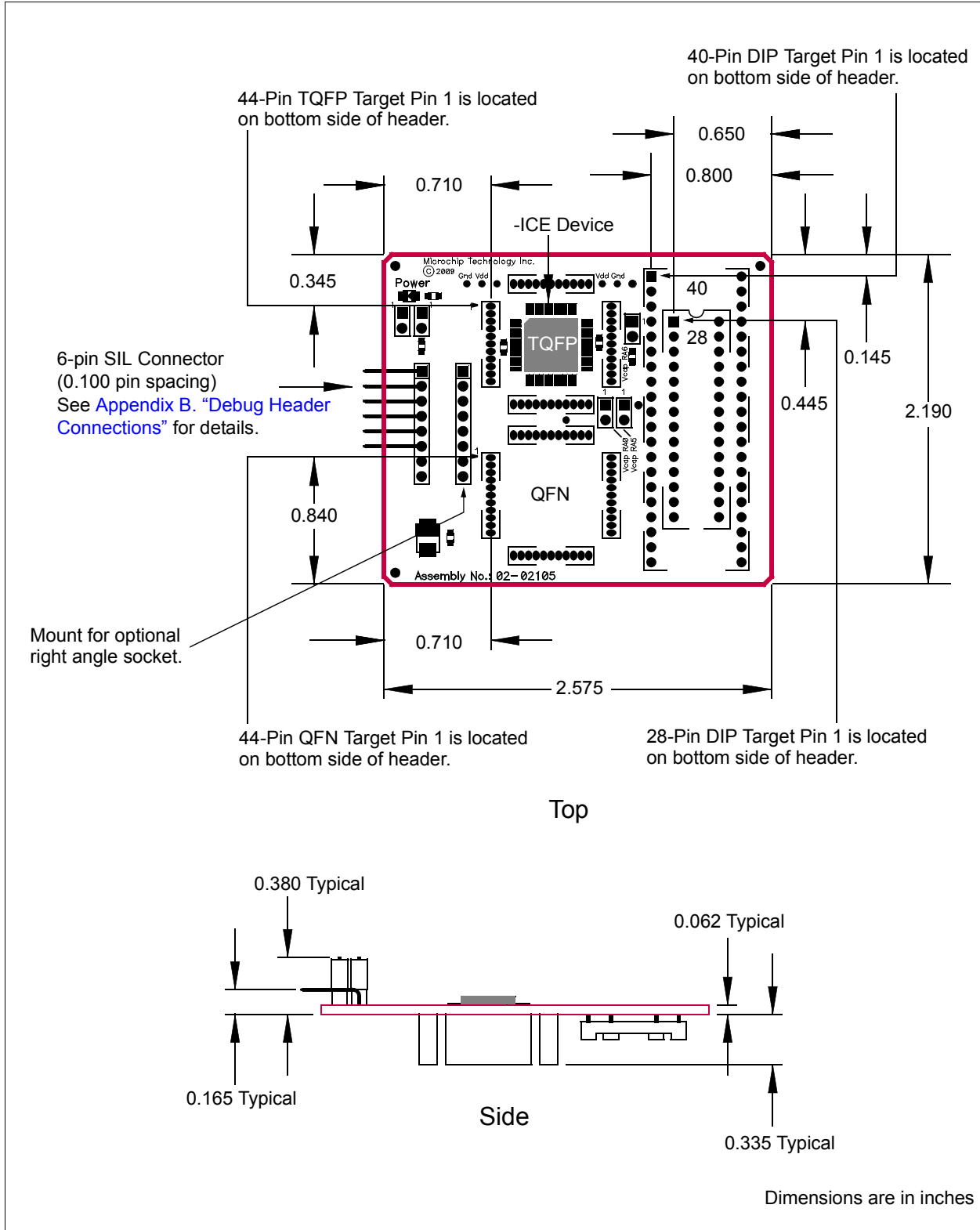

## AC244049, AC244050

### Header Identification

The AC number is used for ordering the Processor Extension Pak, which contains the debug header. However, this number is not on the header, as the board may be used for multiple headers by inserting different -ICE/-ICD devices. To identify these headers, use the following information.

AC Number	-ICE/-ICD Device	Board Assembly Number
AC244049	PIC12F752-ICE	02-02300
AC244050	PIC12HV752-ICE	

### Header Setup and Operation

For these headers, there are no jumpers/switches. MPLAB X IDE will use its selected device to choose the correct device to emulate.

### Header Limitations

Sometimes a header device (-ICE/-ICD) has operational issues or errata. To determine if a device on a header has limitations, see your hardware tool documentation.

# PEP and Debug Header Specification

## Header Dimensions

The figure below lists the dimensions for the debug headers. Dimensions are design values in inches.

If the length and/or width of the debug header is too large a footprint for the target board, consider using stand-offs, transition sockets or other extenders in the header connection socket to raise the header above the target.

**FIGURE 3-17: DIMENSIONS - AC244049, AC244050**

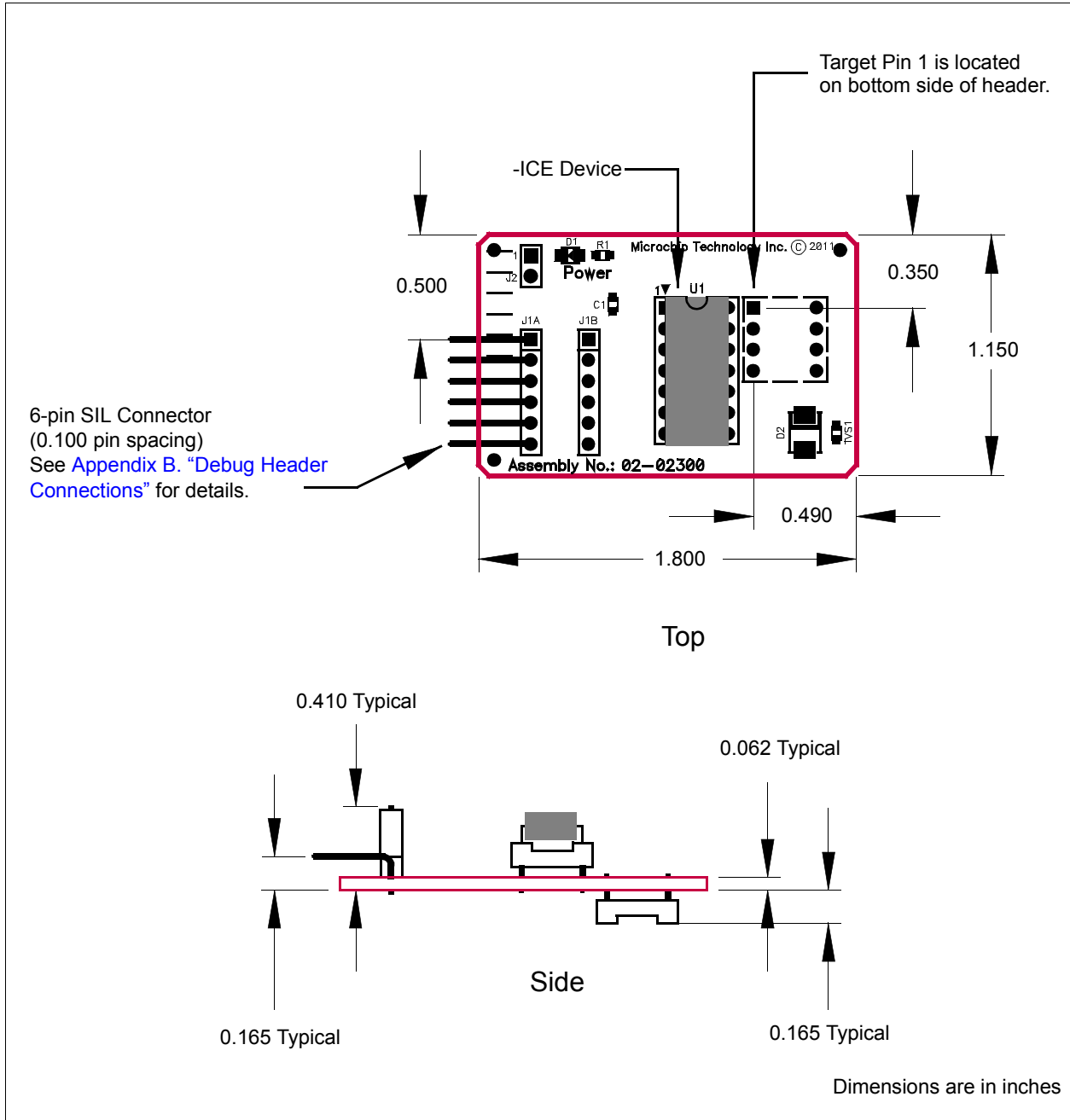

## AC244053, AC244054

### Header Identification

The AC number is used for ordering the Processor Extension Pak, which contains the debug header. However, this number is not on the header, as the board may be used for multiple headers by inserting different -ICE/-ICD devices. To identify these headers, use the following information.

AC Number	-ICE/-ICD Device	Board Assembly Number
AC244053	PIC16F1459-ICE	02-02031
AC244054	PIC16LF1459-ICE	

### Header Setup and Operation

For this header, there are no jumpers/switches. MPLAB X IDE will use its selected device to choose the correct device to emulate.

### Header Limitations

Sometimes a header device (-ICE/-ICD) has operational issues or errata. To determine if a device on a header has limitations, see your hardware tool documentation.

# PEP and Debug Header Specification

## Header Dimensions

The figure below lists the dimensions for the debug header. Dimensions are design values in inches.

If the length and/or width of the debug header is too large a footprint for the target board, consider using stand-offs, transition sockets or other extenders in the header connection socket to raise the header above the target.

**FIGURE 3-18: DIMENSIONS – AC244053, AC224054**

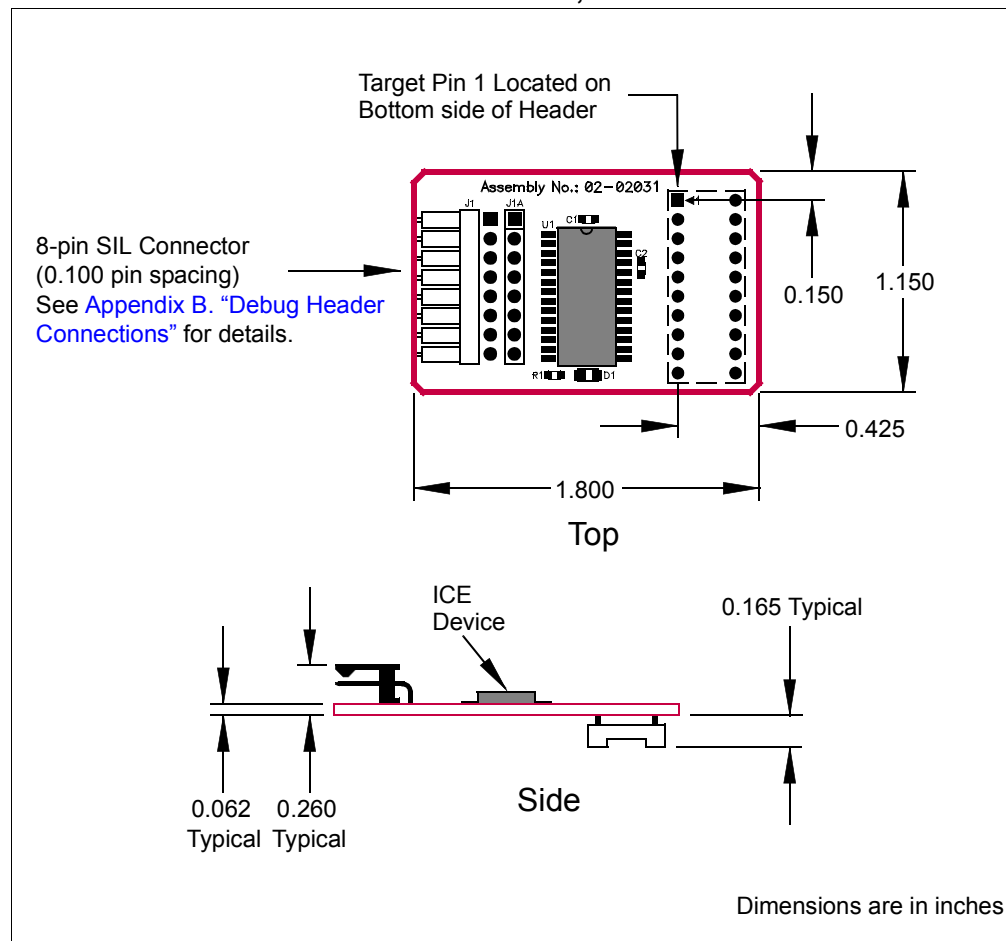



## AC244060

### Header Identification

The AC number is used for ordering the Processor Extension Pak, which contains the debug header. However, this number is not on the header, as the board may be used for multiple headers by inserting different -ICE/-ICD devices. To identify this header, use the following information.

AC Number	-ICE/-ICD Device	Board Assembly Number
AC244060	PIC16F753-ICE	02-10153

### Header Setup and Operation

For this header, there are no jumpers/switches. MPLAB X IDE will use its selected device to choose the correct device to emulate.

### Header Limitations

Sometimes a header device (-ICE/-ICD) has operational issues or errata. To determine if a device on a header has limitations, see your hardware tool documentation.

# PEP and Debug Header Specification

## Header Dimensions

The figure below lists the dimensions for the debug header. Dimensions are design values in inches.

If the length and/or width of the debug header is too large a footprint for the target board, consider using stand-offs, transition sockets or other extenders in the header connection socket to raise the header above the target.

**FIGURE 3-19: DIMENSIONS – AC244060**

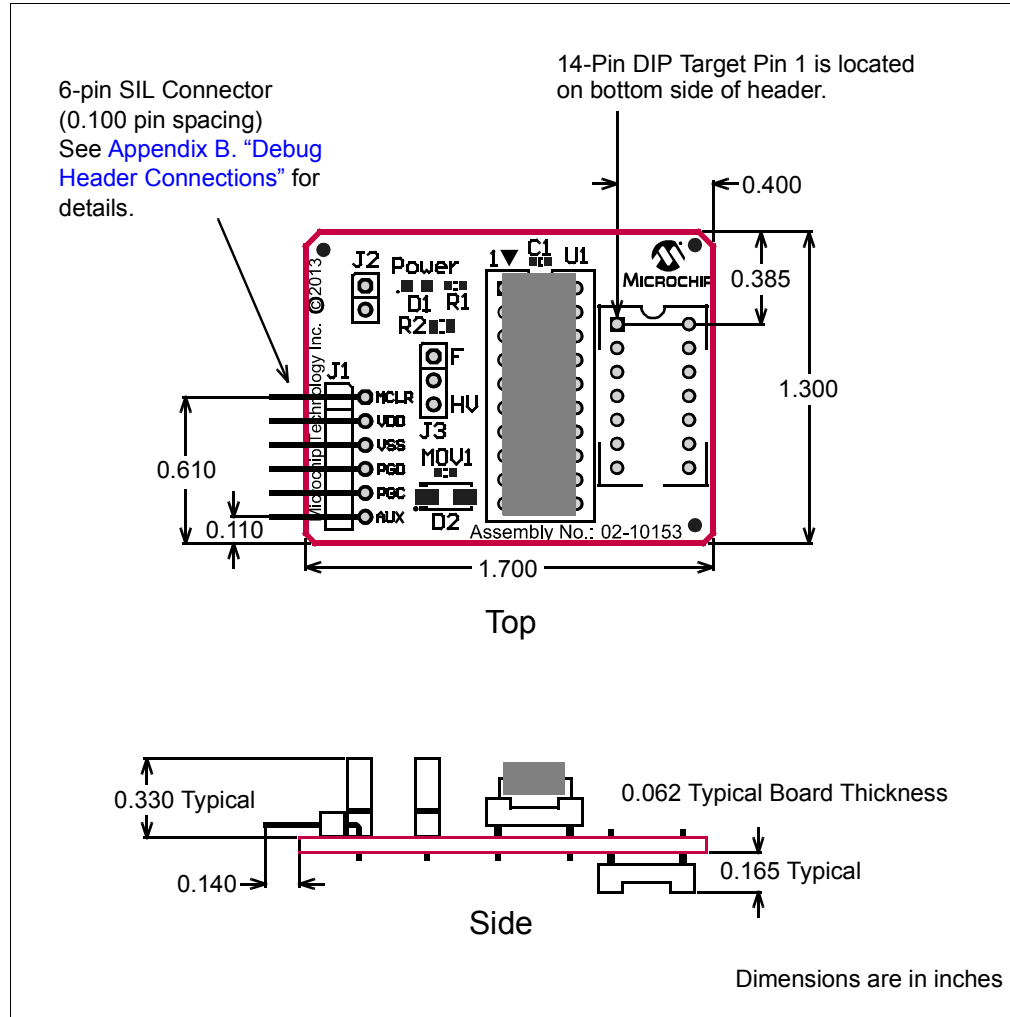

**Appendix A. Debug Header Target Footprints**

**A.1 INTRODUCTION**

To connect a debug header directly to a target board (without the use of a transition socket) the following information will be helpful.

- [DIP Device Footprints](#)
- [TQFP/PLCC Device Footprints](#)

**A.2 DIP DEVICE FOOTPRINTS**

The DIP device adapter footprint shown below will accept adapter plugs like Samtec series APA plugs. These plugs can be soldered in place during development/emulation and eliminate the need for other sockets.

**FIGURE A-20: DIP FOOTPRINT**

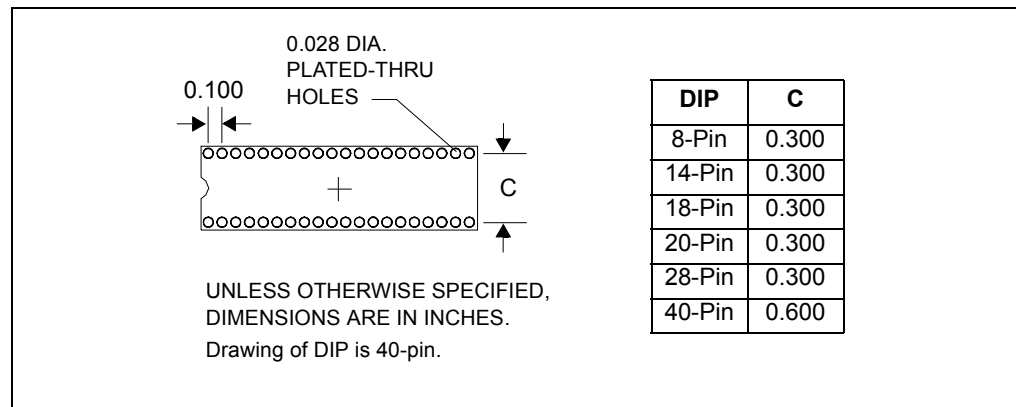

**A.3 TQFP/PLCC DEVICE FOOTPRINTS**

TQFP/PLCC device adapter footprints shown will accept board stackers like Samtec series DWM 0.050 Pitch Stackers. These stackers can be soldered in place during development/emulation and eliminate the need for other sockets.

**FIGURE A-21: SINGLE-ROW TQFP/PLCC FOOTPRINT**

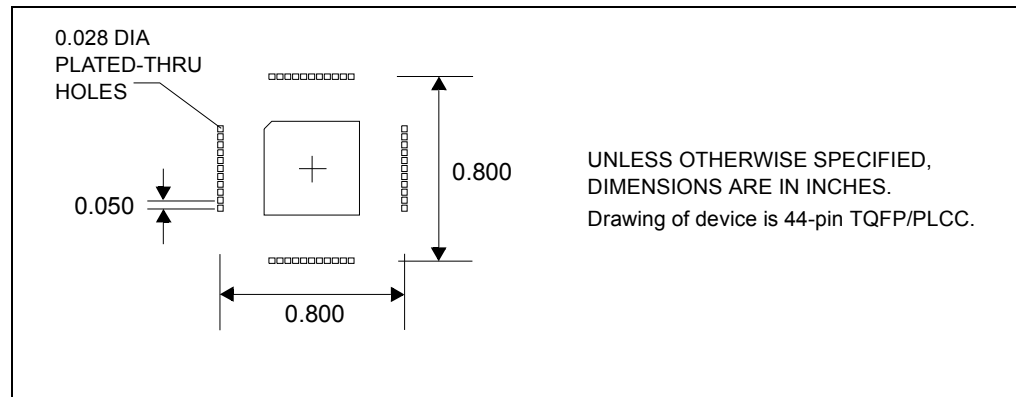

# PEP and Debug Header Specification

**FIGURE A-22: DOUBLE AND TRIPLE-ROW TQFP/PLCC FOOTPRINT**

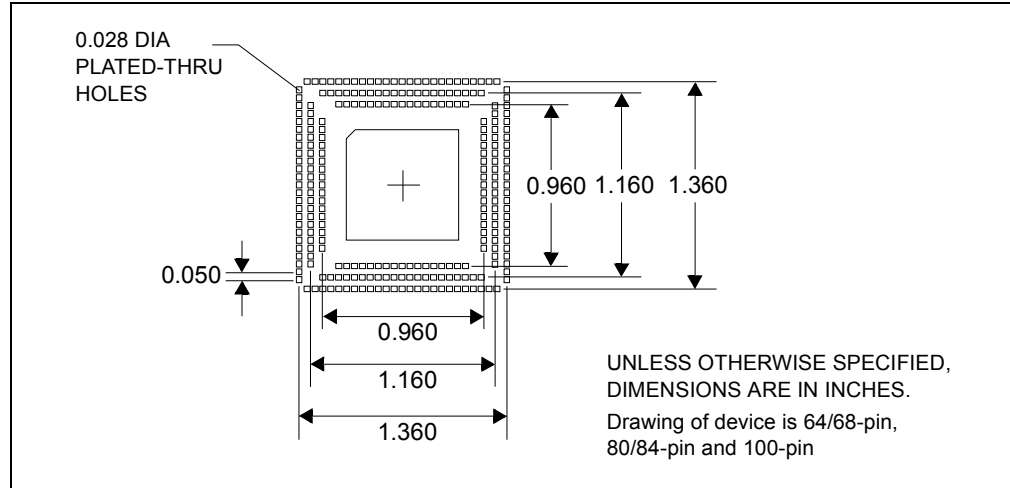

Header pin-out matches the PLCC package. PLCC will map to TQFP as follows:

- Header to 44-pin TQFP – one-to-one mapping.
- Header to 64-pin TQFP – see [Figure A-23](#) for mapping.
- Header to 80-pin TQFP – see [Figure A-24](#) for mapping.
- Header to 100-pin TQFP – one-to-one mapping.

**FIGURE A-23: HEADER TO 64-PIN TQFP**

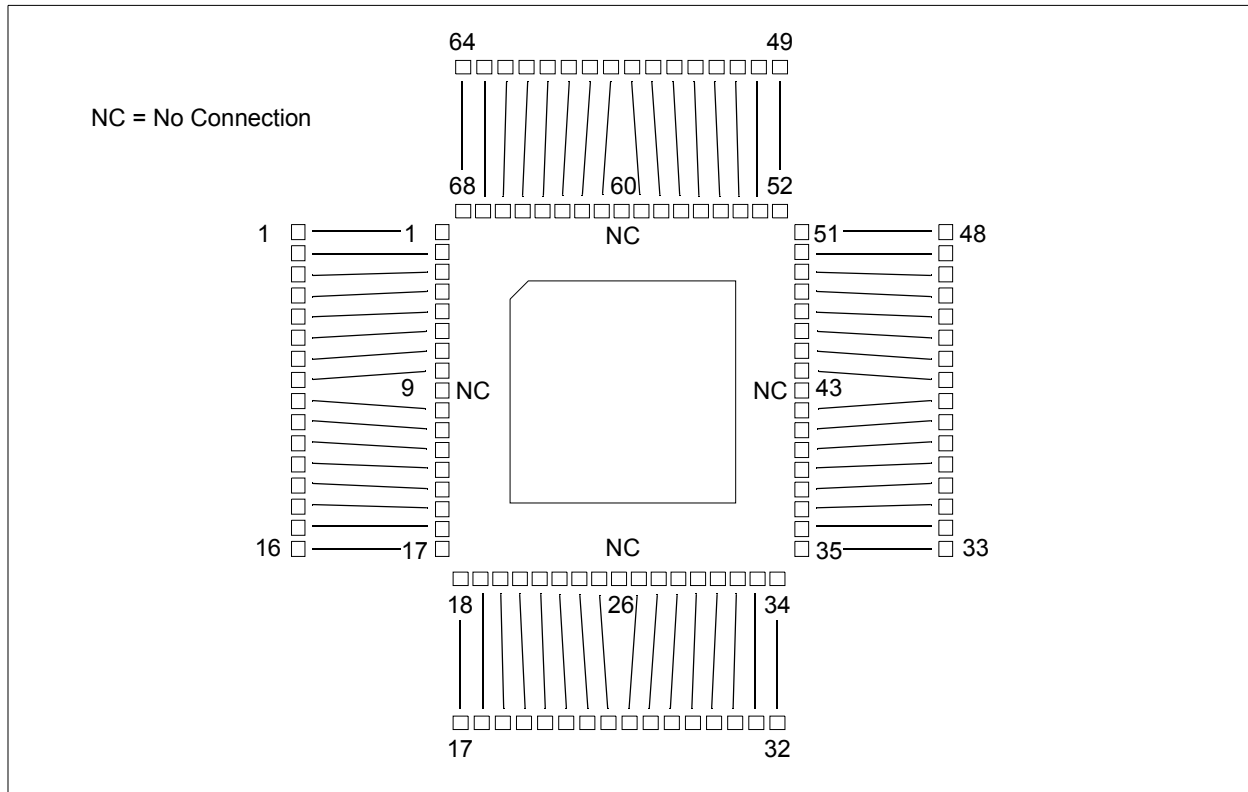

# Debug Header Target Footprints

FIGURE A-24: HEADER TO 80-PIN TQFP

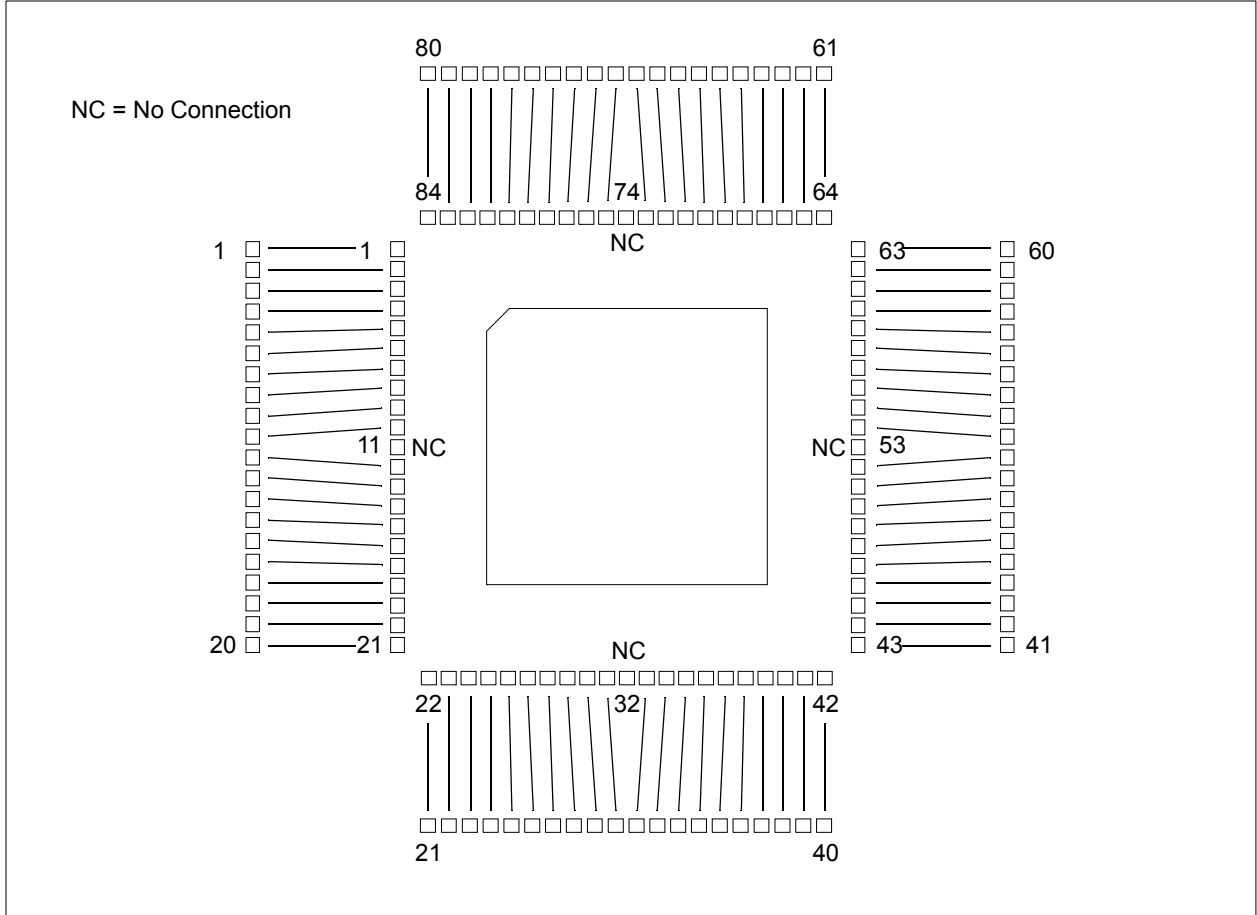

# PEP and Debug Header Specification

---

NOTES:

---

---

**Appendix B. Debug Header Connections**

---

---

**B.1 INTRODUCTION**

The following types of debug header are described here. Information on connecting development tools to the headers is presented here, as well.

- [6-Pin Modular Connector](#)
- [8-Pin SIL Connector](#)
- [6-Pin SIL Connector](#)
- [SIL Optional Connection](#)
- [Modular-to-SIL Adapter](#)
- [Ordering Information](#)

**B.2 6-PIN MODULAR CONNECTOR**

Debug headers with 6-pin modular (RJ-11/ICSP) connectors can connect directly to the following tools:

- MPLAB REAL ICE in-circuit emulator (Standard Driver Board)
- MPLAB ICD 3

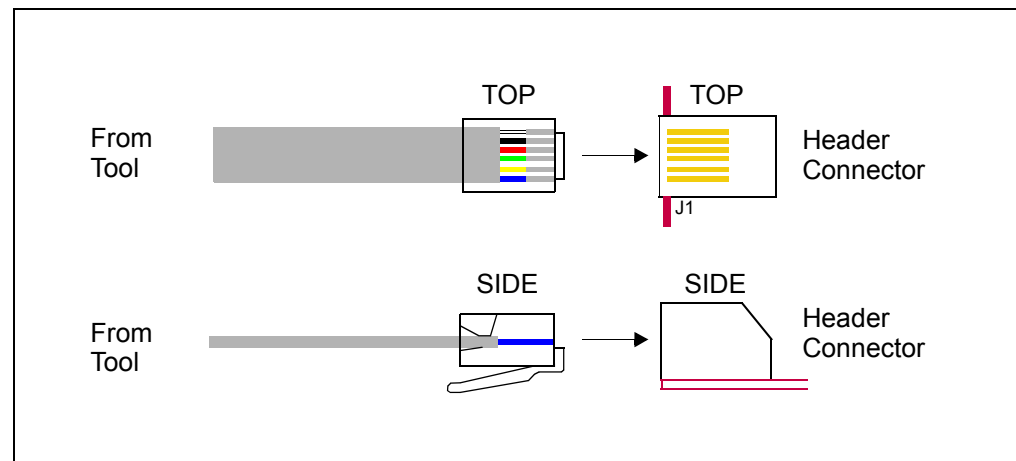
**FIGURE B-1: MODULAR CONNECTION**

# PEP and Debug Header Specification

## B.3 8-PIN SIL CONNECTOR

Debug headers with 8-pin Single In-Line (SIL) connectors are compatible with the tools listed below.

### PICKit 3 Programmer/Debug Express

The 6-pin socket of the PICKit 3 may be connected to the 8 header pins by removing the two DAT and CLK pins. However, this may compromise future use of these pins/functions with other tools.

**FIGURE B-2: 8-PIN SIL CONNECTION TO A PICKIT**

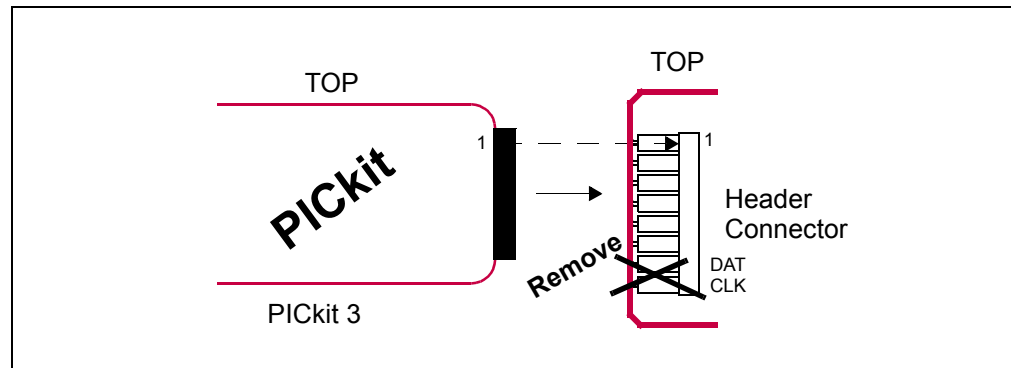

### MPLAB ICD 3 In-Circuit Debugger

The 6-pin modular cable attached to the MPLAB ICD 3 may be connected to the 8 header pins through the [Modular-to-SIL Adapter](#).

### MPLAB REAL ICE In-Circuit Emulator

The 6-pin modular cable attached to the Standard Driver Board may be connected to the 8 header pins through the [Modular-to-SIL Adapter](#). No SPI trace is available with this connection because of the loss of the DAT and CLK pins.

The 8-pin socket of the High Speed Driver Board or optional Isolation Unit may be connected directly to the 8 header pins. Be sure to line up pin 1 on the board with pin 1 on the header.

**FIGURE B-3: 8-PIN SIL CONNECTION TO AN EMULATOR**

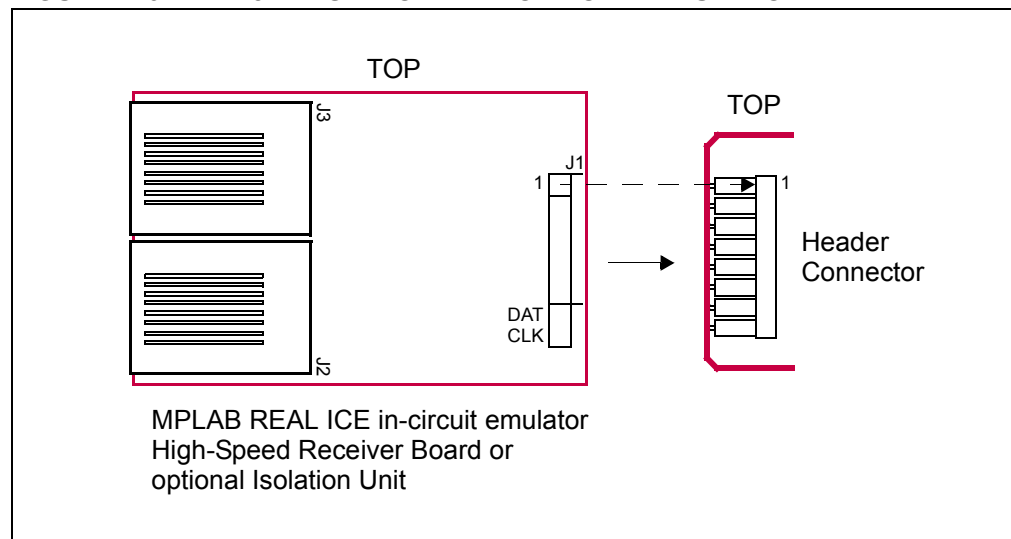



## B.4 6-PIN SIL CONNECTOR

Debug headers with 6-pin SIL connectors are compatible with the tools listed below.

### PICKit 3 Programmer/Debug Express

The 6-pin socket of the PICKit 3 may be directly connected to the 6 header pins. Be sure to line up pin 1 on the PICKit with pin 1 on the header.

**FIGURE B-4: 6-PIN SIL CONNECTION TO A PICKIT**

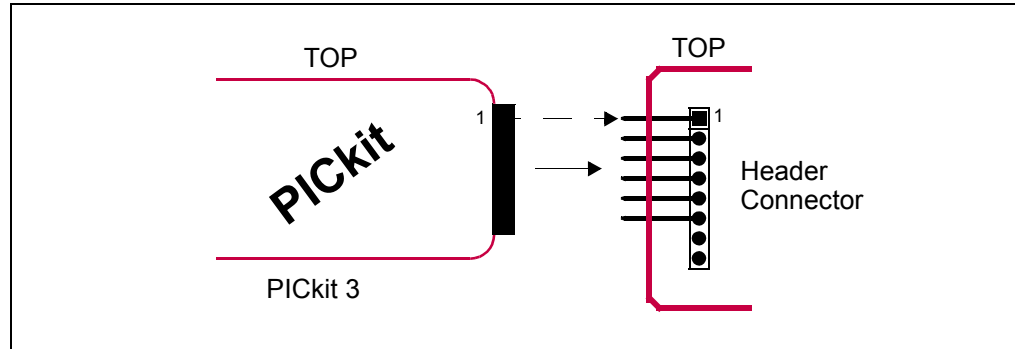

### MPLAB ICD 3 In-Circuit Debugger

The 6-pin modular cable attached to the MPLAB ICD 3 may be connected to the 6 header pins through the [Modular-to-SIL Adapter](#).

### MPLAB REAL ICE In-Circuit Emulator

The 6-pin modular cable attached to the Standard Driver Board may be connected to the 6 header pins through the [Modular-to-SIL Adapter](#). No SPI trace is available with this connection because of the loss of the DAT and CLK pins.

The 8-pin socket of the High Speed Driver Board or optional Isolation Unit may be connected directly to the 6 header pins. Be sure to line up pin 1 on the board with pin 1 on the header.

**Note:** No SPI trace is possible in this case because of the loss of DAT and CLK pins. However, if the device supports SPI, two additional header pins can be attached to add this functionality.

**FIGURE B-5: 6-PIN SIL CONNECTION TO AN EMULATOR**

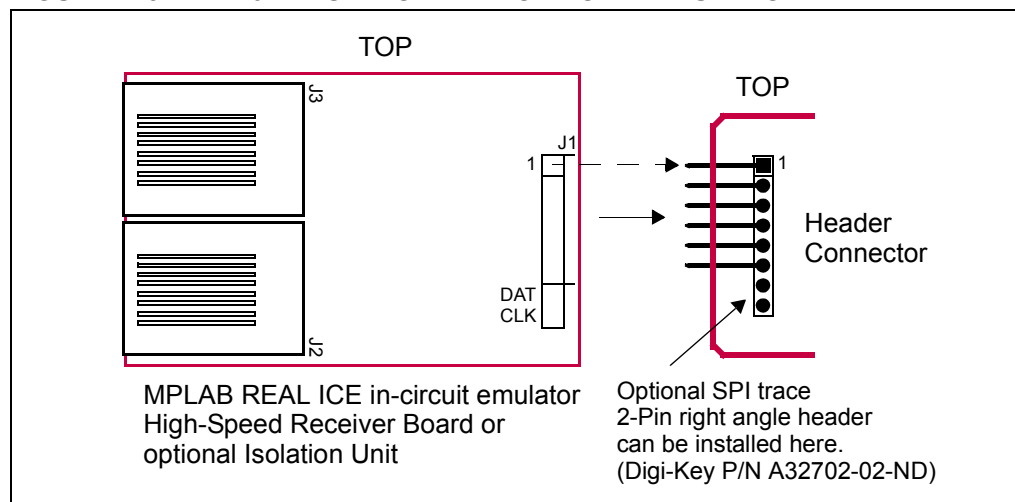

# PEP and Debug Header Specification

## B.5 SIL OPTIONAL CONNECTION

Debug headers with 6- and 8-pin SIL connectors have an additional unpopulated connector available for customer use. This connector has the same pinout as the SIL connector. Solder wires to access individual pins or attach an entire vertical connector.

**FIGURE B-6: SIL OPTIONAL CONNECTION**

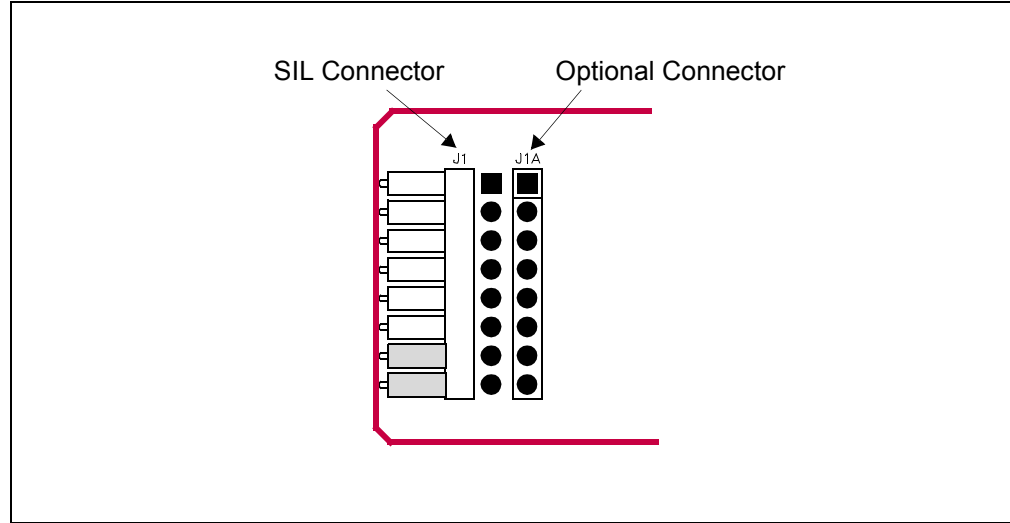

## B.6 MODULAR-TO-SIL ADAPTER

To adapt a 6-pin modular connector to an 8-pin SIL (Single In-Line) connector, you can use this adapter. You can also use this adapter for a 6-pin modular connector to an 6-pin SIL connector. In either case, **line up pin 1 of J1 with pin 1 of the 6- or 8-pin header connector.**

**FIGURE B-7: MODULAR-TO-SIL ADAPTER CONNECTION**

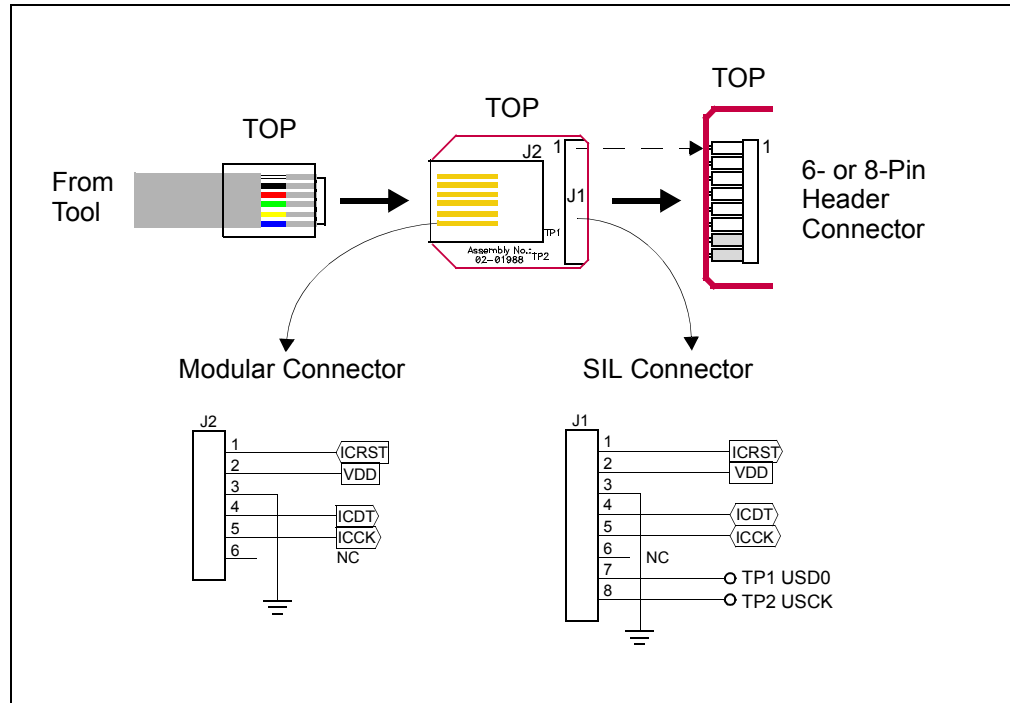

## B.7 ORDERING INFORMATION

To order the development tools and other hardware shown here, please refer to the table below.

**TABLE B-1: MICROCHIP HARDWARE ORDERING NUMBERS**

Hardware	Order #
MPLAB REAL ICE in-circuit emulator (Standard Communication)	DV244005
MPLAB REAL ICE in-circuit emulator (High-Speed Communication) - Performance Pak	AC244002
MPLAB REAL ICE Isolation Unit (works with High-Speed Communication)	AC244005
MPLAB ICD 3	DV164035
PICkit 3 Debug Express	DV164131
Modular-to-SIL Adapter	AC164110

# PEP and Debug Header Specification

---

NOTES:

## APPENDIX C: REVISION HISTORY

### C.1 Revision N (February 2006)

- Added Appendix A: Revision History
- Updated document to reflect support of additional tools
- Additional minor corrections throughout document text

### C.2 Revision P (September 2007)

- Updated document to reflect support of additional tools
- Additional minor corrections throughout document text

### C.3 Revision Q (December 2008)

- Added limitations to header setup sections as needed.
- Changed “ICD Headers” and “ICE Headers” to “Required Headers” and “Optional Headers” and move sections as necessary.
- Rearranged sections to organize by header (AC) number.

### C.4 Revision R (April 2009)

- Added board dimensions
- Removed header pinouts
- Added board identification info
- Added “why use a header” section
- Added footprint appendix
- Changed MPLAB ICD 2 and MPLAB ICD 3 references to generic debug tool
- Added MPLAB REAL ICE in-circuit emulator and MPLAB ICD 3 as programmers

### C.5 Revision S (July 2010)

- Added AC244028
- Added Header Connections chapter
- Added AC244033, AC244034
- Moved limitations to common Limitations file and added small section referencing Help files
- Added PIC12F617 to AC162083

### C.6 Revision T (February 2012)

- Added AC244043 and AC244044 and associated devices
- Removed Header Setup and Operation for AC244045

### C.7 Revision U (June 2012)

- Name changed from “Debug Header Specification” to “Processor Extension Pak & Header Specification”.
- “Processor Extension Pak and Header Defined” section added.
- “MPLAB IDE and MPLAB X IDE Use with Headers” section added.

### C.8 Revision V (September 2015)

- Removed references to MPLAB IDE v8 and tools supported only on that IDE. Also removed references to PICKIT 2.
- Numbering added to chapters.
- Chapter 1. “PEP and Debug Header Overview” - reorganized for better information flow.
- Chapter 2. “Required Debug Headers” - Added AC244061, AC244062.
- Chapter 3. “Optional Debug Headers” - Added AC244049, AC244059, AC244060.

### C.9 Revision W (November 2015)

Chapter 1. “PEP and Debug Header Overview” - corrected typo in Section 1.3, and added 2 links.

# PEP and Debug Header Specification

---

---

NOTES:



# PEP AND DEBUG HEADER SPECIFICATION

## Index

### Numerics

6-Pin Modular Connector .....	87
6-Pin SIL Connector .....	89
8-Pin SIL Connector .....	88

### A

AC162050 .....	16
AC162052 .....	18
AC162053 .....	20
AC162054 .....	20
AC162055 .....	18
AC162056 .....	18
AC162057 .....	18
AC162058 .....	16
AC162059 .....	22
AC162060 .....	24
AC162061 .....	26
AC162062 .....	48
AC162064 .....	50
AC162065 .....	52
AC162066 .....	28
AC162067 .....	55
AC162070 .....	22
AC162074 .....	55
AC162078 .....	58
AC162079 .....	48
AC162083 .....	30
AC162087 .....	48
AC162088 .....	61
AC162091 .....	48
AC162094 .....	61
AC162096 .....	22
AC244022 .....	52
AC244023 .....	32
AC244024 .....	32
AC244026 .....	64
AC244027 .....	64
AC244028 .....	34
AC244033 .....	67
AC244034 .....	67
AC244035 .....	69
AC244036 .....	69
AC244043 .....	71
AC244044 .....	71
AC244045 .....	36
AC244046 .....	73
AC244047 .....	73
AC244048 .....	75
AC244049 .....	77
AC244050 .....	77
AC244051 .....	38
AC244052 .....	38

AC244053 .....	79
AC244054 .....	79
AC244060 .....	81
AC244061 .....	38
AC244062 .....	40
Additional Information .....	14

### C

Calibration Bits .....	14
------------------------	----

### J

Jumper Settings	16, 18, 24, 28, 34, 48, 55, 58, 61, 64, 69
-----------------	--

### M

Modular Connector .....	87
Modular-to-SIL Adapter .....	90

### O

Ordering Hardware .....	91
-------------------------	----

### P

Performance .....	14
PIC10F200 .....	15
PIC10F202 .....	15
PIC10F204 .....	15
PIC10F206 .....	15
PIC10F220 .....	15
PIC10F222 .....	15
PIC10F320 .....	15
PIC10F322 .....	15
PIC10LF320 .....	15
PIC10LF322 .....	15
PIC12F1501 .....	15
PIC12F1822 .....	44
PIC12F1840 .....	44
PIC12F508 .....	15
PIC12F509 .....	15
PIC12F510 .....	15
PIC12F519 .....	15
PIC12F609 .....	15, 30
PIC12F615 .....	15, 30
PIC12F617 .....	15, 30
PIC12F629 .....	15, 16
PIC12F635 .....	15, 18
PIC12F675 .....	15, 16
PIC12F683 .....	15, 16
PIC12F752 .....	43
PIC12HV609 .....	15, 30
PIC12HV615 .....	15, 30
PIC12HV752 .....	43
PIC12LF1501 .....	15
PIC12LF1822 .....	44
PIC12LF1840 .....	44

# PEP and Debug Header Specification

---

PIC16F1454 .....	43	PIC16LF1509 .....	43
PIC16F1455 .....	43	PIC16LF1823 .....	44
PIC16F1458 .....	43	PIC16LF1824 .....	44
PIC16F1459 .....	43	PIC16LF1825 .....	44
PIC16F1503 .....	16	PIC16LF1826 .....	44
PIC16F1507 .....	16	PIC16LF1827 .....	44
PIC16F1508 .....	43	PIC16LF1829 .....	44
PIC16F1509 .....	43	PIC16LF1847 .....	44
PIC16F1823 .....	44	PIC16LF1902 .....	44
PIC16F1824 .....	44	PIC16LF1903 .....	44
PIC16F1825 .....	44	PIC16LF1904 .....	44
PIC16F1826 .....	44	PIC16LF1906 .....	44
PIC16F1827 .....	44	PIC16LF1907 .....	44
PIC16F1829 .....	44	PIC16LF1933 .....	44
PIC16F1847 .....	44	PIC16LF1934 .....	44
PIC16F1933 .....	44	PIC16LF1936 .....	44
PIC16F1934 .....	44	PIC16LF1937 .....	44
PIC16F1936 .....	44	PIC16LF1938 .....	44
PIC16F1937 .....	44	PIC16LF1939 .....	44
PIC16F1938 .....	44	PIC16LF722 .....	43
PIC16F1939 .....	44	PIC16LF723 .....	43
PIC16F505 .....	15	PIC16LF724 .....	43
PIC16F506 .....	15	PIC16LF726 .....	43
PIC16F526 .....	15	PIC16LF727 .....	43
PIC16F527 .....	15	PIC18F1230 .....	45, 58
PIC16F570 .....	15	PIC18F1330 .....	45, 58
PIC16F610 .....	15, 30	PIC18F13K22 .....	45
PIC16F616 .....	15, 30	PIC18F13K50 .....	16
PIC16F627A .....	15, 20	PIC18F14K22 .....	45
PIC16F628A .....	15, 20	PIC18F14K50 .....	16
PIC16F630 .....	15, 18	PIC18F24J10 .....	45
PIC16F631 .....	15, 26	PIC18F25J10 .....	45, 55
PIC16F636 .....	15, 18	PIC18F44J10 .....	45
PIC16F639 .....	15, 28	PIC18F45J10 .....	45, 55
PIC16F648A .....	16, 20	PIC18F63J11 .....	45
PIC16F676 .....	16, 18	PIC18F63J90 .....	45
PIC16F677 .....	16, 26	PIC18F64J11 .....	45
PIC16F684 .....	16, 18	PIC18F64J16 .....	45
PIC16F685 .....	16, 26	PIC18F64J90 .....	45
PIC16F687 .....	16, 26	PIC18F64J95 .....	45
PIC16F688 .....	16, 18	PIC18F65J10 .....	45
PIC16F689 .....	16, 26	PIC18F65J11 .....	45
PIC16F690 .....	16, 26	PIC18F65J15 .....	45
PIC16F716 .....	16, 20	PIC18F65J16 .....	46
PIC16F722 .....	43	PIC18F65J50 .....	46
PIC16F723 .....	43	PIC18F65J55 .....	46
PIC16F724 .....	43	PIC18F65J90 .....	45
PIC16F726 .....	43	PIC18F66J10 .....	45
PIC16F727 .....	43	PIC18F66J11 .....	46
PIC16F785 .....	16, 24	PIC18F66J15 .....	45
PIC16HV610 .....	15, 30	PIC18F66J16 .....	46
PIC16HV616 .....	15, 30	PIC18F66J50 .....	46
PIC16HV785 .....	16, 24	PIC18F66J55 .....	46
PIC16LF1454 .....	43	PIC18F66J60 .....	46
PIC16LF1455 .....	43	PIC18F66J65 .....	46
PIC16LF1458 .....	43	PIC18F67J10 .....	45
PIC16LF1459 .....	43	PIC18F67J11 .....	46
PIC16LF1503 .....	16	PIC18F67J50 .....	46
PIC16LF1507 .....	16	PIC18F67J60 .....	46
PIC16LF1508 .....	43	PIC18F83J11 .....	45



PIC18F83J90 .....	45
PIC18F84J11 .....	45
PIC18F84J16 .....	45
PIC18F84J90 .....	45
PIC18F84J95 .....	45
PIC18F85J10 .....	45
PIC18F85J11 .....	45
PIC18F85J15 .....	45
PIC18F85J16 .....	46
PIC18F85J50 .....	46
PIC18F85J55 .....	46
PIC18F85J90 .....	45
PIC18F86J10 .....	45
PIC18F86J11 .....	46
PIC18F86J15 .....	45
PIC18F86J16 .....	46
PIC18F86J50 .....	46
PIC18F86J55 .....	46
PIC18F86J60 .....	46
PIC18F86J65 .....	46
PIC18F87J10 .....	45
PIC18F87J11 .....	46
PIC18F87J50 .....	46
PIC18F87J60 .....	46
PIC18F96J60 .....	46
PIC18F96J65 .....	46
PIC18F97J60 .....	46
PIC18LF13K22 .....	45
PIC18LF13K50 .....	16
PIC18LF14K22 .....	45
PIC18LF14K50 .....	16
PIC18LF24J10 .....	45
PIC18LF25J10 .....	45, 55
PIC18LF44J10 .....	45
PIC18LF45J10 .....	45, 55
PIC24F04KA200 .....	16
PIC24F04KA201 .....	16
PIC24F08KA101 .....	47
PIC24F08KA102 .....	47
PIC24F16KA101 .....	47
PIC24F16KA102 .....	47
PIC24FJ128GA006 .....	47
PIC24FJ128GA008 .....	47
PIC24FJ128GA010 .....	47
PIC24FJ16GA002 .....	47
PIC24FJ16GA004 .....	47
PIC24FJ32GA002 .....	47
PIC24FJ32GA004 .....	47
PIC24FJ48GA002 .....	47
PIC24FJ48GA004 .....	47
PIC24FJ64GA002 .....	47
PIC24FJ64GA004 .....	47
PIC24FJ64GA006 .....	47
PIC24FJ64GA008 .....	47
PIC24FJ64GA010 .....	47
PIC24FJ96GA006 .....	47
PIC24FJ96GA008 .....	47
PIC24FJ96GA010 .....	47
PICDEM HPC Explorer Board .....	48
Pin Count .....	15, 43, 45, 47

## S

SIL Connector, 6 Pin .....	89
SIL Connector, 8 Pin .....	88
Switch Settings .....	26
Switch Settings, Rotary .....	30

## T

Transition Socket .....	11
-------------------------	----

## V

Vdd Max .....	15, 43, 45, 47
Vddcore Max .....	15, 43, 45, 47



# MICROCHIP

## Worldwide Sales and Service

### AMERICAS

**Corporate Office**  
 2355 West Chandler Blvd.  
 Chandler, AZ 85224-6199  
 Tel: 480-792-7200  
 Fax: 480-792-7277  
 Technical Support:  
<http://www.microchip.com/support>  
 Web Address:  
[www.microchip.com](http://www.microchip.com)

**Atlanta**  
 Duluth, GA  
 Tel: 678-957-9614  
 Fax: 678-957-1455

**Austin, TX**  
 Tel: 512-257-3370

**Boston**  
 Westborough, MA  
 Tel: 774-760-0087  
 Fax: 774-760-0088

**Chicago**  
 Itasca, IL  
 Tel: 630-285-0071  
 Fax: 630-285-0075

**Cleveland**  
 Independence, OH  
 Tel: 216-447-0464  
 Fax: 216-447-0643

**Dallas**  
 Addison, TX  
 Tel: 972-818-7423  
 Fax: 972-818-2924

**Detroit**  
 Novi, MI  
 Tel: 248-848-4000

**Houston, TX**  
 Tel: 281-894-5983

**Indianapolis**  
 Noblesville, IN  
 Tel: 317-773-8323  
 Fax: 317-773-5453

**Los Angeles**  
 Mission Viejo, CA  
 Tel: 949-462-9523  
 Fax: 949-462-9608

**New York, NY**  
 Tel: 631-435-6000

**San Jose, CA**  
 Tel: 408-735-9110

**Canada - Toronto**  
 Tel: 905-673-0699  
 Fax: 905-673-6509

### ASIA/PACIFIC

**Asia Pacific Office**  
 Suites 3707-14, 37th Floor  
 Tower 6, The Gateway  
 Harbour City, Kowloon

**Hong Kong**  
 Tel: 852-2943-5100  
 Fax: 852-2401-3431

**Australia - Sydney**  
 Tel: 61-2-9868-6733  
 Fax: 61-2-9868-6755

**China - Beijing**  
 Tel: 86-10-8569-7000  
 Fax: 86-10-8528-2104

**China - Chengdu**  
 Tel: 86-28-8665-5511  
 Fax: 86-28-8665-7889

**China - Chongqing**  
 Tel: 86-23-8980-9588  
 Fax: 86-23-8980-9500

**China - Dongguan**  
 Tel: 86-769-8702-9880

**China - Hangzhou**  
 Tel: 86-571-8792-8115  
 Fax: 86-571-8792-8116

**China - Hong Kong SAR**  
 Tel: 852-2943-5100  
 Fax: 852-2401-3431

**China - Nanjing**  
 Tel: 86-25-8473-2460  
 Fax: 86-25-8473-2470

**China - Qingdao**  
 Tel: 86-532-8502-7355  
 Fax: 86-532-8502-7205

**China - Shanghai**  
 Tel: 86-21-5407-5533  
 Fax: 86-21-5407-5066

**China - Shenyang**  
 Tel: 86-24-2334-2829  
 Fax: 86-24-2334-2393

**China - Shenzhen**  
 Tel: 86-755-8864-2200  
 Fax: 86-755-8203-1760

**China - Wuhan**  
 Tel: 86-27-5980-5300  
 Fax: 86-27-5980-5118

**China - Xian**  
 Tel: 86-29-8833-7252  
 Fax: 86-29-8833-7256

### ASIA/PACIFIC

**China - Xiamen**  
 Tel: 86-592-2388138  
 Fax: 86-592-2388130

**China - Zhuhai**  
 Tel: 86-756-3210040  
 Fax: 86-756-3210049

**India - Bangalore**  
 Tel: 91-80-3090-4444  
 Fax: 91-80-3090-4123

**India - New Delhi**  
 Tel: 91-11-4160-8631  
 Fax: 91-11-4160-8632

**India - Pune**  
 Tel: 91-20-3019-1500

**Japan - Osaka**  
 Tel: 81-6-6152-7160  
 Fax: 81-6-6152-9310

**Japan - Tokyo**  
 Tel: 81-3-6880-3770  
 Fax: 81-3-6880-3771

**Korea - Daegu**  
 Tel: 82-53-744-4301  
 Fax: 82-53-744-4302

**Korea - Seoul**  
 Tel: 82-2-554-7200  
 Fax: 82-2-558-5932 or  
 82-2-558-5934

**Malaysia - Kuala Lumpur**  
 Tel: 60-3-6201-9857  
 Fax: 60-3-6201-9859

**Malaysia - Penang**  
 Tel: 60-4-227-8870  
 Fax: 60-4-227-4068

**Philippines - Manila**  
 Tel: 63-2-634-9065  
 Fax: 63-2-634-9069

**Singapore**  
 Tel: 65-6334-8870  
 Fax: 65-6334-8850

**Taiwan - Hsin Chu**  
 Tel: 886-3-5778-366  
 Fax: 886-3-5770-955

**Taiwan - Kaohsiung**  
 Tel: 886-7-213-7828

**Taiwan - Taipei**  
 Tel: 886-2-2508-8600  
 Fax: 886-2-2508-0102

**Thailand - Bangkok**  
 Tel: 66-2-694-1351  
 Fax: 66-2-694-1350

### EUROPE

**Austria - Wels**  
 Tel: 43-7242-2244-39  
 Fax: 43-7242-2244-393

**Denmark - Copenhagen**  
 Tel: 45-4450-2828  
 Fax: 45-4485-2829

**France - Paris**  
 Tel: 33-1-69-53-63-20  
 Fax: 33-1-69-30-90-79

**Germany - Dusseldorf**  
 Tel: 49-2129-3766400

**Germany - Karlsruhe**  
 Tel: 49-721-625370

**Germany - Munich**  
 Tel: 49-89-627-144-0  
 Fax: 49-89-627-144-44

**Italy - Milan**  
 Tel: 39-0331-742611  
 Fax: 39-0331-466781

**Italy - Venice**  
 Tel: 39-049-7625286

**Netherlands - Drunen**  
 Tel: 31-416-690399  
 Fax: 31-416-690340

**Poland - Warsaw**  
 Tel: 48-22-3325737

**Spain - Madrid**  
 Tel: 34-91-708-08-90  
 Fax: 34-91-708-08-91

**Sweden - Stockholm**  
 Tel: 46-8-5090-4654

**UK - Wokingham**  
 Tel: 44-118-921-5800  
 Fax: 44-118-921-5820

07/14/15

## X-ON Electronics

Largest Supplier of Electrical and Electronic Components

*Click to view similar products for [Emulators/Simulators](#) category:*

*Click to view products by [Microchip](#) manufacturer:*

Other Similar products are found below :

[QB-78K0RKE3L-TB](#) [ST7MDT2-EMU2B](#) [RTE0T0002LKCE00000R](#) [AC244060](#) [7027-D-350](#) [AC244061](#) [J-Link ULTRA+](#) [CP2102](#) [ADZS-ICE-2000](#) [USB-EA-CONVZ](#) [IJET-TRACE-CM-L](#) [Btip](#) [AC244002](#) [AC244003](#) [AC244063](#) [AC244064](#) [AC244065](#) [AC244066](#) [CWH-UTP-ONCE-HE](#) [TMS320-XDS100-V2](#) [TMS320-XDS100-V3](#) [QB-78K0KC2L-TB](#) [QB-78K0SKB1-TB](#) [J-Link](#) [J-Link PRO](#) [TMDSEMU560V2STM-U](#) [TMDSEMU560V2STM-UE](#) [TMDSEMUPROTRACE](#) [QB-78K0IB2-TB](#) [QB-78K0RIE3-TB](#) [QB-78K0RKG3-TB](#) [CY3250-24X33](#) [QB-78K0KF2-TB](#) [AFM201TI-AY2LED2](#) [AFW121T-EVB](#) [CE118M12](#) [ESP32-A1S](#) [ESP32-CAM](#) [ESP32-S](#) [BH-USB-100v2-ARM](#) [BH-USB-100v2D](#) [BH-USB-560v2](#) [BH-XDS-560v2](#) [BH-XDS-560v2-BP](#) [IM1275](#) [IM1227](#) [IM1259G](#) [IM3319](#) [IM1253B\(D\)](#) [IM1253B](#)