

High-Performance WVGA Display Module with maXTouch[®] Information Sheet

The High-Performance WVGA Display Module with maXTouch (AC320005-5) is designed for evaluating the Microchip graphics display solution and graphics library for 32-bit microcontrollers. This board is compatible with both versions of the Multimedia Expansion Board II (DM320005-2 or DM320005-5), as well as with Xplained Pro and Xplained Ultra evaluation kits. This board has a TFT 800 x 480 display with a 24-bit parallel RGB interface with a maXTouch capacitive touch interface.

Features

- 800 x 480 TFT display
- maXTouch MXT460
- QTouch[®] QT1070 (with four navigation keys)
- 4 K-bit 1-wire EEPROM
- Integrated Projective Capacitive Touch (PCAP) panel

Running the High-Performance WVGA Display Module with maXTouch Demonstration Code

For free Microchip demonstration code and additional information, visit the MPLAB[®] Harmony web page at: www.microchip.com/Harmony.

After MPLAB Harmony is installed, refer to the following MPLAB Harmony installation folder for demonstration purposes:

```
C:\microchip\harmony\\apps\gfx
```

To work with older Xplained Pro and Xplained Ultra evaluation kits, disconnect the ribbon connector from the adapter board and connect it to the GFX port (50 flex) of the Xplained Pro or Xplained Ultra.

FIGURE 1: WVGA DISPLAY MODULE BLOCK DIAGRAM

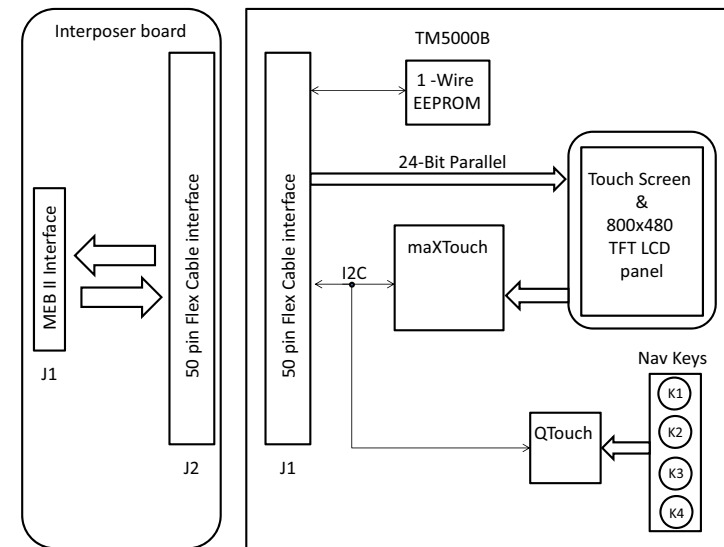

Americas

Atlanta - 678-957-9614
 Austin - 512-257-3370
 Boston - 774-760-0087
 Chicago - 630-285-0071
 Cleveland - 216-447-0464
 Dallas - 972-818-7423
 Detroit - 248-848-4000
 Houston - 281-894-5983
 Indianapolis - 317-773-8323
 Los Angeles - 949-462-9523
 New York - 631-435-6000
 Phoenix - 480-792-7200
 Santa Clara - 408-961-6444
 Toronto - 905-673-0699

Europe

Austria - Wels - 43-7242-2244-39
 Denmark - Copenhagen - 45-4450-2828
 France - Paris - 33-1-69-53-63-20
 Germany - Munich - 49-89-627-144-0
 Italy - Milan - 39-0331-742611
 Netherlands - Drunen - 31-416-690399
 Spain - Madrid - 34-91-708-08-90
 UK - Wokingham - 44-118-921-5869

Asia/Pacific

Australia - Sydney - 61-2-9868-6733
 China - Beijing - 86-10-8569-2100

Asia/Pacific (Continued)

China - Chengdu - 86-28-8665-5511
 China - Chongqing - 86-23-8980-9588
 China - Hangzhou - 86-571-8792-8115
 China - Hong Kong SAR - 852-2943-5100
 China - Nanjing - 86-25-8473-2460
 China - Qingdao - 86-532-8502-7355
 China - Shanghai - 86-21-5407-5533
 China - Shenyang - 86-24-2334-2829
 China - Shenzhen - 86-755-8864-2200
 China - Wuhan - 86-27-5980-5300
 China - Xiamen - 86-592-2388138
 China - Xian - 86-29-8833-7252
 China - Zhuhai - 86-756-3210040
 India - Bangalore - 91-80-3090-4444
 India - New Delhi - 91-11-4160-8631
 India - Pune - 91-20-3019-1500
 Japan - Osaka - 81-6-6152-7160
 Japan - Tokyo - 81-3-6880-3770
 Korea - Daegu - 82-53-744-4301
 Korea - Seoul - 82-2-554-7200
 Malaysia - Kuala Lumpur - 60-3-6201-9857
 Malaysia - Penang - 60-4-227-8870
 Philippines - Manila - 63-2-634-9065
 Singapore - 65-6334-8870
 Taiwan - Hsin Chu - 886-3-5778-366
 Taiwan - Kaohsiung - 886-7-213-7840
 Taiwan - Taipei - 886-2-2508-8600
 Thailand - Bangkok - 66-2-694-1351

01/11/17



Microchip Technology Inc. • 2355 West Chandler Blvd. • Chandler, AZ 85224-6199

www.microchip.com

The Microchip name and logo, the Microchip logo, and MPLAB are registered trademarks of Microchip Technology Incorporated in the U.S.A. and other countries. All other trademarks mentioned herein are property of their respective companies. © 2017, Microchip Technology Incorporated, Printed in the U.S.A. All Rights Reserved. 01/17

DS50002681A



High-Performance WVGA Display Module with maXTouch® Board Timing Specifications

TABLE 1: TIMING SPECIFICATION VALUES

Parameter	Symbol	Spec.			Unit
		Min.	Typ.	Max.	
Clock Cycle	1/PCLK	-	30	40	MHz
Hsync Cycle	1/th	-	10.7	-	kHz
Vsync Cycle	1/tv	-	19	-	Hz
Horizontal Signal					
Horizontal Cycle	th	-	928	-	CLK
Horizontal Display Period	thd	800	800	800	CLK
Horizontal Front Porch	thfp	-	40	-	CLK
Horizontal Pulse width	thpw	1	48	-	CLK
Horizontal Back Porch	thbp	-	40	-	CLK
Vertical Signals					
Vertical Cycle	tv	-	525	-	Hsync
Vertical Display Period	tvd	480	480	480	Hsync
Vertical Front Porch	tvfp	-	13	-	Hsync
Vertical Pulse Width	tvpw	1	3	-	Hsync
Vertical Back Porch	tvbp	-	29	-	Hsync

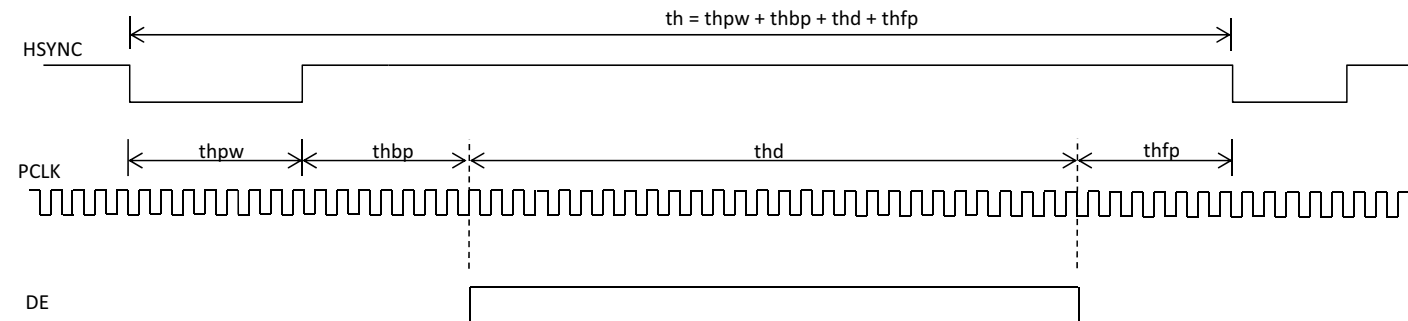
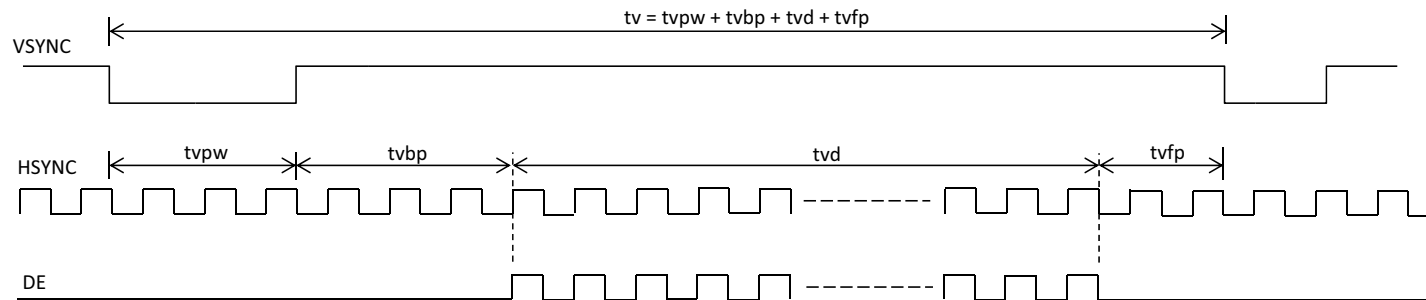

High-Performance WVGA Display Module with maXTouch® Board Schematics

Bottom Contacts Use Type 1 FFC

Xplained Interface

1	ONE_WIRE
2	GND
3	LCDDAT0
4	LCDDAT1
5	LCDDAT2
6	LCDDAT3
7	GND
8	LCDDAT4
9	LCDDAT5
10	LCDDAT6
11	LCDDAT7
12	GND
13	LCDDAT8
14	LCDDAT9
15	LCDDAT10
16	LCDDAT11
17	GND
18	LCDDAT12
19	LCDDAT13
20	LCDDAT14
21	LCDDAT15
22	GND
23	LCDDAT16
24	LCDDAT17
25	LCDDAT18
26	LCDDAT19
27	GND
28	LCDDAT20
29	LCDDAT21
30	LCDDAT22
31	LCDDAT23
32	GND
33	PCLK
34	VSYNC
35	HSYNC
36	DE
37	SCK
38	MOSI
39	MISO
40	~SS
41	DISP
42	SDA
43	SCL
44	~CHG_mxt
45	~CHG_QT
46	LCD_PWM
47	~Reset_IN
48	+Vout
49	+Vout
50	GND

CON50

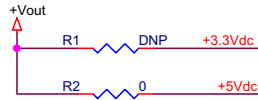

~CHG_QT is connected to Pin 53 for future use if desired.

SCK, MOSI, MISO and ~SS are connected to Pins 54, 56, 58 and 57 (respectively) for future use if desired.

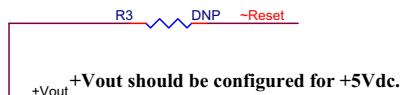

Debug Header

1	GND
2	~CHG_QT
3	~CHG_mxt
4	SCL
5	SDA
6	DE
7	HSYNC
8	VSYNC
9	PCLK
10	GND

CON10

Mounting Holes

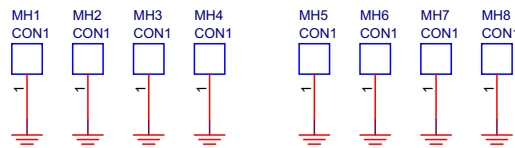

MEB II Interface

GND	1	2	GND
GND	3	4	GND
+3.3Vdc	5	6	+3.3Vdc
LCDDAT12	7	8	LCDDAT8
LCDDAT13	9	10	LCDDAT9
LCDDAT14	11	12	LCDDAT10
LCDDAT15	13	14	LCDDAT11
LCDDAT16	15	16	LCDDAT0
LCDDAT17	17	18	LCDDAT1
LCDDAT18	19	20	LCDDAT2
LCDDAT19	21	22	LCDDAT3
LCDDAT20	23	24	LCDDAT4
GND	25	26	GND
+3.3Vdc	27	28	+3.3Vdc
LCDDAT21	29	30	LCDDAT5
LCDDAT22	31	32	LCDDAT6
LCDDAT23	33	34	LCDDAT7
PCLK	35	36	ONE_WIRE
VSYNC	37	38	HSYNC
DE	39	40	
~CHG_mxt	41	42	SCL
	43	44	SDA
LCD_PWM	45	46	DISP
GND	47	48	GND
+5Vdc	49	50	+5Vdc
~CHG_QT	51	52	SCK
~Reset	53	54	MOSI
~SS	55	56	MISO
GND	57	58	GND
	59	60	

DF12 (3.0)-60DS-05V (86)

ONE_WIRE is connected to Pin 38 for future use if desired.

Microchip "LCD_CS" is not used by PDA LCD interface

Microchip "LCD_Reset" is connected to PDA "DISP". When DISP is low the LCD is in standby mode. When DISP is high the LCD is in normal display mode.

X-ON Electronics

Largest Supplier of Electrical and Electronic Components

Click to view similar products for [Display Development Tools](#) category:

Click to view products by [Microchip](#) manufacturer:

Other Similar products are found below :

[KIT 60121-3](#) [S5U13U11P00C100](#) [121CBL02-RPK](#) [KIT 60145-3](#) [S5U13748P00C100](#) [DFR0413](#) [DLPLCR90EVM](#) [DLPLCR50XEVM](#)
[MAX20069EVKIT#](#) [KIT95000-3](#) [LCD-16396](#) [PIM370](#) [1109](#) [MCIMX-LVDS1](#) [MIKROE-2449](#) [MIKROE-2453](#) [131](#) [DEV-13628](#) [1590](#)
[MIKROE-2269](#) [1601](#) [1770](#) [1947](#) [1983](#) [1987](#) [2050](#) [2218](#) [2260](#) [2345](#) [2418](#) [2423](#) [2454](#) [2455](#) [2478](#) [2674](#) [SK-220RD-PI](#) [FIT0477](#) [333](#) [334](#)
[TE-M321-SDK](#) [DFR0428](#) [cs-epapersk-03](#) [338](#) [DEV-14442](#) [FIT0478](#) [cs-paperino-01](#) [OM-E-OLE](#) [ALTHSMCMIPILCD](#) [ASD2421-R](#)
[TDP0500T800480PCAP](#)