



MICROCHIP

**MIC28515 75V/5A HLL
Step-Down Evaluation Board
User's Guide**

Note the following details of the code protection feature on Microchip devices:

- Microchip products meet the specification contained in their particular Microchip Data Sheet.
- Microchip believes that its family of products is one of the most secure families of its kind on the market today, when used in the intended manner and under normal conditions.
- There are dishonest and possibly illegal methods used to breach the code protection feature. All of these methods, to our knowledge, require using the Microchip products in a manner outside the operating specifications contained in Microchip's Data Sheets. Most likely, the person doing so is engaged in theft of intellectual property.
- Microchip is willing to work with the customer who is concerned about the integrity of their code.
- Neither Microchip nor any other semiconductor manufacturer can guarantee the security of their code. Code protection does not mean that we are guaranteeing the product as "unbreakable."

Code protection is constantly evolving. We at Microchip are committed to continuously improving the code protection features of our products. Attempts to break Microchip's code protection feature may be a violation of the Digital Millennium Copyright Act. If such acts allow unauthorized access to your software or other copyrighted work, you may have a right to sue for relief under that Act.

Information contained in this publication regarding device applications and the like is provided only for your convenience and may be superseded by updates. It is your responsibility to ensure that your application meets with your specifications. MICROCHIP MAKES NO REPRESENTATIONS OR WARRANTIES OF ANY KIND WHETHER EXPRESS OR IMPLIED, WRITTEN OR ORAL, STATUTORY OR OTHERWISE, RELATED TO THE INFORMATION, INCLUDING BUT NOT LIMITED TO ITS CONDITION, QUALITY, PERFORMANCE, MERCHANTABILITY OR FITNESS FOR PURPOSE. Microchip disclaims all liability arising from this information and its use. Use of Microchip devices in life support and/or safety applications is entirely at the buyer's risk, and the buyer agrees to defend, indemnify and hold harmless Microchip from any and all damages, claims, suits, or expenses resulting from such use. No licenses are conveyed, implicitly or otherwise, under any Microchip intellectual property rights unless otherwise stated.

Microchip received ISO/TS-16949:2009 certification for its worldwide headquarters, design and wafer fabrication facilities in Chandler and Tempe, Arizona; Gresham, Oregon and design centers in California and India. The Company's quality system processes and procedures are for its PIC® MCUs and dsPIC® DSCs, KEELOQ® code hopping devices, Serial EEPROMs, microperipherals, nonvolatile memory and analog products. In addition, Microchip's quality system for the design and manufacture of development systems is ISO 9001:2000 certified.

**QUALITY MANAGEMENT SYSTEM
CERTIFIED BY DNV
= ISO/TS 16949 =**

Trademarks

The Microchip name and logo, the Microchip logo, AnyRate, AVR, AVR logo, AVR Freaks, BeaconThings, BitCloud, CryptoMemory, CryptoRF, dsPIC, FlashFlex, flexPWR, Helder, JukeBlox, KEELOQ, KEELOQ logo, Klear, LANCheck, LINK MD, maXStylus, maXTouch, MediaLB, megaAVR, MOST, MOST logo, MPLAB, OptoLyzr, PIC, picoPower, PICSTART, PIC32 logo, Prochip Designer, QTouch, RightTouch, SAM-BA, SpyNIC, SST, SST Logo, SuperFlash, tinyAVR, UNI/O, and XMEGA are registered trademarks of Microchip Technology Incorporated in the U.S.A. and other countries.

ClockWorks, The Embedded Control Solutions Company, EtherSynch, Hyper Speed Control, HyperLight Load, IntelliMOS, mTouch, Precision Edge, and Quiet-Wire are registered trademarks of Microchip Technology Incorporated in the U.S.A.

Adjacent Key Suppression, AKS, Analog-for-the-Digital Age, Any Capacitor, AnyIn, AnyOut, BodyCom, chipKIT, chipKIT logo, CodeGuard, CryptoAuthentication, CryptoCompanion, CryptoController, dsPICDEM, dsPICDEM.net, Dynamic Average Matching, DAM, ECAN, EtherGREEN, In-Circuit Serial Programming, ICSP, Inter-Chip Connectivity, JitterBlocker, KlearNet, KlearNet logo, Mindi, MiWi, motorBench, MPASM, MPF, MPLAB Certified logo, MPLIB, MPLINK, MultiTRAK, NetDetach, Omniscient Code Generation, PICDEM, PICDEM.net, PICKit, PICtail, PureSilicon, QMatrix, RightTouch logo, REAL ICE, Ripple Blocker, SAM-ICE, Serial Quad I/O, SMART-I.S., SQI, SuperSwitcher, SuperSwitcher II, Total Endurance, TSHARC, USBCheck, VariSense, ViewSpan, WiperLock, Wireless DNA, and ZENA are trademarks of Microchip Technology Incorporated in the U.S.A. and other countries.

SQTP is a service mark of Microchip Technology Incorporated in the U.S.A.

Silicon Storage Technology is a registered trademark of Microchip Technology Inc. in other countries.

GestIC is a registered trademark of Microchip Technology Germany II GmbH & Co. KG, a subsidiary of Microchip Technology Inc., in other countries.

All other trademarks mentioned herein are property of their respective companies.

© 2017, Microchip Technology Incorporated, All Rights Reserved.
ISBN: 978-1-5224-1728-6

Object of Declaration: MIC28515 75V/5A HLL Step-Down Evaluation Board User's Guide

EU Declaration of Conformity

This declaration of conformity is issued by the manufacturer.

The development/evaluation tool is designed to be used for research and development in a laboratory environment. This development/evaluation tool is not a Finished Appliance, nor is it intended for incorporation into Finished Appliances that are made commercially available as single functional units to end users under EU EMC Directive 2004/108/EC and as supported by the European Commission's Guide for the EMC Directive 2004/108/EC (8th February 2010).

This development/evaluation tool complies with EU RoHS2 Directive 2011/65/EU.

This development/evaluation tool, when incorporating wireless and radio-telecom functionality, is in compliance with the essential requirement and other relevant provisions of the R&TTE Directive 1999/5/EC and the FCC rules as stated in the declaration of conformity provided in the module datasheet and the module product page available at www.microchip.com.

For information regarding the exclusive, limited warranties applicable to Microchip products, please see Microchip's standard terms and conditions of sale, which are printed on our sales documentation and available at www.microchip.com.

Signed for and on behalf of Microchip Technology Inc. at Chandler, Arizona, USA.

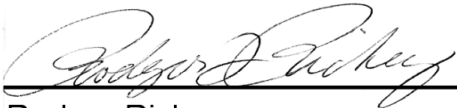

Rodger Richey
Director of Development Tools



Date

NOTES:



MIC28515 75V/5A HLL STEP-DOWN EVALUATION BOARD USER'S GUIDE

Table of Contents

Preface	7
Introduction.....	7
Document Layout	7
Conventions Used in this Guide	8
Recommended Reading.....	9
The Microchip Website	9
Customer Support	9
Document Revision History	9
Chapter 1. Product Overview	
1.1 Introduction	11
1.2 MIC28515 75V/5A HLL Step-Down Evaluation Board Overview	11
1.3 MIC28515 75V/5A HLL Step-Down Evaluation Board Features	12
1.4 What the MIC28515 75V/5A HLL Step-Down Evaluation Board Kit Contains	12
Chapter 2. Installation and Operation	
2.1 System and Configuration Requirements	13
2.2 Board Setup	13
2.3 Circuit Description	14
2.3.1 Feedback Resistors	14
2.3.2 SW Node	15
2.3.3 Current Limit	15
2.3.4 Loop Gain Measurement	15
2.3.5 Setting the Switching Frequency	15
2.3.6 MODE selection pin	16
2.3.7 Auxiliary Bootstrap LDO (EXTVDD)	16
Appendix A. Schematic and Layouts	
A.1 Introduction	17
A.2 Board – Schematic	18
A.3 Board – Top Silk	19
A.4 Board – Top Copper and Silk	19
A.5 Board – Top Copper	20
A.6 Board – MID Copper Layer 1	20
A.7 Board – Mid Copper Layer 2	21
A.8 Board – Bottom Copper	21
A.9 Board – Bottom Copper and Silk	22
Appendix B. Bill of Materials (BOM)	23
Worldwide Sales and Service	25



MIC28515 75V/5A HLL STEP-DOWN EVALUATION BOARD USER'S GUIDE

Preface

NOTICE TO CUSTOMERS

All documentation becomes dated, and this manual is no exception. Microchip tools and documentation are constantly evolving to meet customer needs, so some actual dialogs and/or tool descriptions may differ from those in this document. Please refer to our website (www.microchip.com) to obtain the latest documentation available.

Documents are identified with a “DS” number. This number is located on the bottom of each page, in front of the page number. The numbering convention for the DS number is “DSXXXXXXXXA”, where “XXXXXXXX” is the document number and “A” is the revision level of the document.

For the most up-to-date information on development tools, see the MPLAB® IDE online help. Select the Help menu, and then Topics, to open a list of available online help files.

INTRODUCTION

This chapter contains general information that will be useful to know before using the MIC28515 75V/5A HLL Step-Down Evaluation Board. Items discussed in this chapter include:

- [Document Layout](#)
- [Conventions Used in this Guide](#)
- [Recommended Reading](#)
- [The Microchip Website](#)
- [Customer Support](#)
- [Document Revision History](#)

DOCUMENT LAYOUT

This document describes how to use the MIC28515 75V/5A HLL Step-Down Evaluation Board as a development tool to emulate and debug firmware on a target board. The manual layout is as follows:

- **Chapter 1. “Product Overview”** – Important information about the MIC28515 75V/5A HLL Step-Down Evaluation Board.
- **Chapter 2. “Installation and Operation”** – Includes instructions on installing and starting the MIC28515 75V/5A HLL Step-Down Evaluation Board.
- **Appendix A. “Schematic and Layouts”** – Shows the schematic and layout diagrams for the MIC28515 75V/5A HLL Step-Down Evaluation Board.
- **Appendix B. “Bill of Materials (BOM)”** – Lists the parts used to build the MIC28515 75V/5A HLL Step-Down Evaluation Board.

CONVENTIONS USED IN THIS GUIDE

This manual uses the following documentation conventions:

DOCUMENTATION CONVENTIONS

Description	Represents	Examples
Arial font:		
Italic characters	Referenced books	<i>MPLAB® IDE User's Guide</i>
	Emphasized text	...is the <i>only</i> compiler...
Initial caps	A window	the Output window
	A dialog	the Settings dialog
	A menu selection	select Enable Programmer
Quotes	A field name in a window or dialog	"Save project before build"
Underlined, italic text with right angle bracket	A menu path	<u><i>File>Save</i></u>
Bold characters	A dialog button	Click OK
	A tab	Click the Power tab
N'Rnnnn	A number in verilog format, where N is the total number of digits, R is the radix and n is a digit.	4'b0010, 2'hF1
Text in angle brackets < >	A key on the keyboard	Press <Enter>, <F1>
Courier New font:		
Plain Courier New	Sample source code	#define START
	Filenames	autoexec.bat
	File paths	c:\mcc18\h
	Keywords	_asm, _endasm, static
	Command-line options	-Opa+, -Opa-
	Bit values	0, 1
	Constants	0xFF, 'A'
Italic Courier New	A variable argument	<i>file.o</i> , where <i>file</i> can be any valid filename
Square brackets []	Optional arguments	mcc18 [options] <i>file</i> [options]
Curly brackets and pipe character: { }	Choice of mutually exclusive arguments; an OR selection	errorlevel {0 1}
Ellipses...	Replaces repeated text	var_name [, var_name...]
	Represents code supplied by user	void main (void) { ... }

RECOMMENDED READING

This user's guide describes how to use the MIC28515 75V/5A HLL Step-Down Evaluation Board. Another useful document is listed below. The following Microchip document is available and recommended as a supplemental reference resource:

- **MIC28515 Data Sheet – “75V/5A Hyper Speed Control[®] Synchronous DC/DC Buck Regulator with External Mode Control” (DS20005762)**

THE MICROCHIP WEBSITE

Microchip provides online support via our website at www.microchip.com. This website is used as a means to make files and information easily available to customers. Accessible by using your favorite Internet browser, the website contains the following information:

- **Product Support** – Data sheets and errata, application notes and sample programs, design resources, user's guides and hardware support documents, latest software releases and archived software
- **General Technical Support** – Frequently Asked Questions (FAQs), technical support requests, online discussion groups, Microchip consultant program member listing
- **Business of Microchip** – Product selector and ordering guides, latest Microchip press releases, listing of seminars and events, listings of Microchip sales offices, distributors and factory representatives

CUSTOMER SUPPORT

Users of Microchip products can receive assistance through several channels:

- Distributor or Representative
- Local Sales Office
- Field Application Engineer (FAE)
- Technical Support

Customers should contact their distributor, representative or field application engineer (FAE) for support. Local sales offices are also available to help customers. A listing of sales offices and locations is included in the back of this document.

Technical support is available through the website at:
<http://www.microchip.com/support>.

DOCUMENT REVISION HISTORY

Revision B (May 2017)

The following is the list of modifications:

- Updated the [Evaluation Board Circuit Description](#).
- Updated the [Board – Mid Copper Layer 2](#).

Revision A (March 2017)

- Initial Release of this Document.

MIC28515 75V/5A HLL Step-Down Evaluation Board User's Guide

NOTES:

Chapter 1. Product Overview

1.1 INTRODUCTION

This chapter provides an overview of the MIC28515 75V/5A HLL Step-Down Evaluation Board and covers the following topics:

- [MIC28515 75V/5A HLL Step-Down Evaluation Board Overview](#)
- [MIC28515 75V/5A HLL Step-Down Evaluation Board Features](#)
- [What the MIC28515 75V/5A HLL Step-Down Evaluation Board Kit Contains](#)

1.2 MIC28515 75V/5A HLL STEP-DOWN EVALUATION BOARD OVERVIEW

The MIC28515 75V/5A HLL Step-Down Evaluation Board is a constant frequency, synchronous buck switcher solution featuring a unique adaptive on-time control architecture. The MIC28515 operates over an input supply range of 4.5V to 75V. The output voltage is adjustable down to 0.6V with an ensured accuracy of $\pm 1\%$. The device operates with a programmable switching frequency from 270 kHz to 800 kHz. The Mode pin allows the user to select either the Forced Continuous Conduction Mode (CCM) or Hyper Light Load (HLL) mode of operation for improved efficiency at light loads.

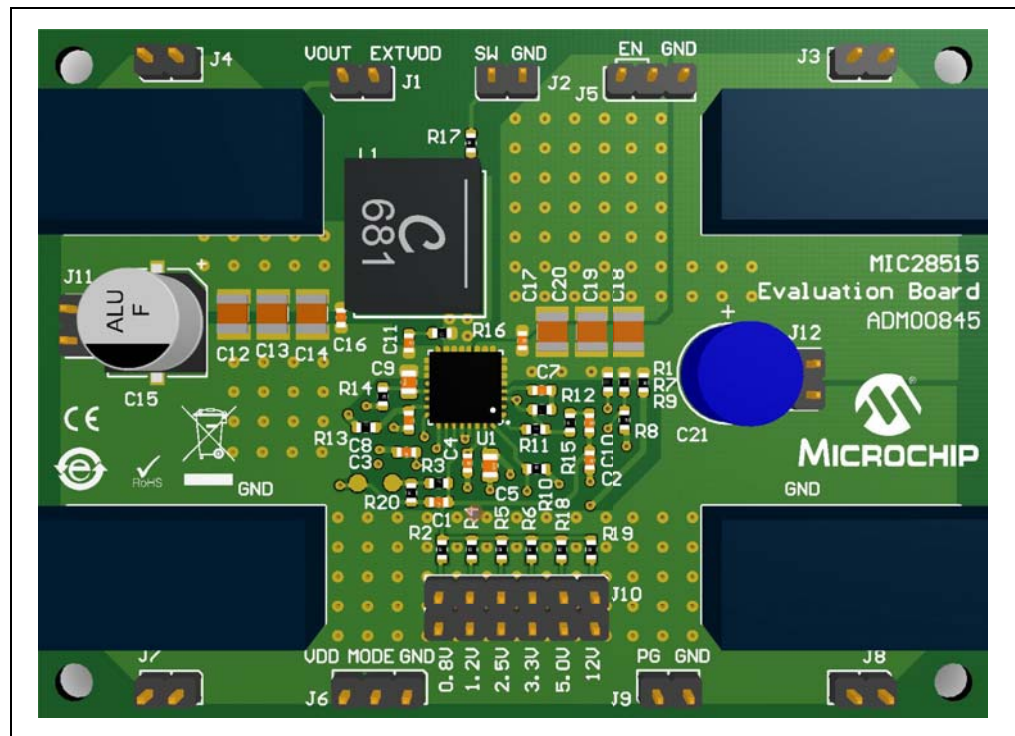

FIGURE 1-1: MIC28515 75V/5A HLL Step-Down Evaluation Board.

1.3 MIC28515 75V/5A HLL STEP-DOWN EVALUATION BOARD FEATURES

The MIC28515 75V/5A HLL Step-Down Evaluation Board:

- Features MODE selection through jumper J6, which allows the user to select either the CCM or HLL mode of operation.
- Features six selectable output voltages: 0.8V, 1.2V, 2.5V, 3.3V, 5V and 12V.
- Features an auxiliary Low Dropout Regulator (LDO), which improves the system efficiency by supplying the internal bias power from the output of the converter.
- Features a logic level Enable (EN) signal that can be used to enable or disable the controller.
- Can start up monotonically into a pre-biased output.
- Features an open-drain Power Good signal (PG), which signals when the output is in regulation.

The basic parameters of the evaluation board are:

- Input: 10V to 75V (optimized for 48V)
- Output: 0.8V, 1.2V, 2.5V, 3.3V, 5V or 12V Selectable through jumper J10 at 5A (default option is set to 5V)
- 300 kHz Switching Frequency (adjustable from 270 kHz to 800 kHz)

1.4 WHAT THE MIC28515 75V/5A HLL STEP-DOWN EVALUATION BOARD KIT CONTAINS

The MIC28515 75V/5A HLL Step-Down Evaluation Board includes the following items:

- MIC28515 75V/5A HLL Step-Down Evaluation Board (ADM00845)
- Important Information Sheet

Chapter 2. Installation and Operation

2.1 SYSTEM AND CONFIGURATION REQUIREMENTS

The MIC28515 75V/5A HLL Step-Down Evaluation Board requires only a single power supply with at least 5A current capability. The MIC28515 has an internal PV_{DD} LDO so no external linear regulator is required to power the internal biasing of the IC. In applications with V_{IN} < +5.5V, PV_{DD} should be tied to V_{IN} to bypass the internal linear regulator. The output load can either be a passive or an active load.

Note: The MIC28515 75V/5A HLL Step-Down Evaluation Board does not have reverse polarity protection. Applying a negative voltage to the V_{IN} and GND terminals may damage the device. The maximum V_{IN} of the board is rated at 75V. Exceeding 75V on the V_{IN} could damage the device.

2.2 BOARD SETUP

Follow these steps prior to using the MIC28515 75V/5A HLL Step-Down Evaluation Board:

1. Connect a supply to the V_{IN} and GND terminals, paying attention to the polarity and the supply range (10V < V_{IN} < 75V). Monitor I_{IN} with a current meter, and the input voltage at the V_{IN} and GND terminals with a voltmeter. Do not apply power until Step 4.
2. Connect a load to the V_{OUT} and GND terminals. The load can be either a passive (resistive) or an active (electronic) type. A current meter may be placed between the V_{OUT} terminal and load to monitor the output current. Ensure the output voltage is monitored at the V_{OUT} terminal.
3. Enable input. An EN connector is provided on the evaluation board for users to easily access the enable feature. Applying an external logic signal on the EN pin to pull it low, or using a jumper to short the EN pin to GND, will shut off the output of the MIC28515 75V/5A HLL Step-Down Evaluation Board.
4. Turn on the V_{IN} supply and verify that the output voltage is regulated to the specific selected voltage.

MIC28515 75V/5A HLL Step-Down Evaluation Board User's Guide

2.3 CIRCUIT DESCRIPTION

This section describes the working principles and limitations that should be taken into account when using the MIC28515 75V/5A HLL Step-Down Evaluation Board. The external components have been selected in order to optimize performance for the specific conditions of $V_{IN} = 48V$ and $V_{OUT} = 5V$. Although the application will behave correctly for other output and input voltages, further optimization (fine-tuning of the inductor, output capacitors and ripple injection components) can be done in order to improve efficiency and transient response.

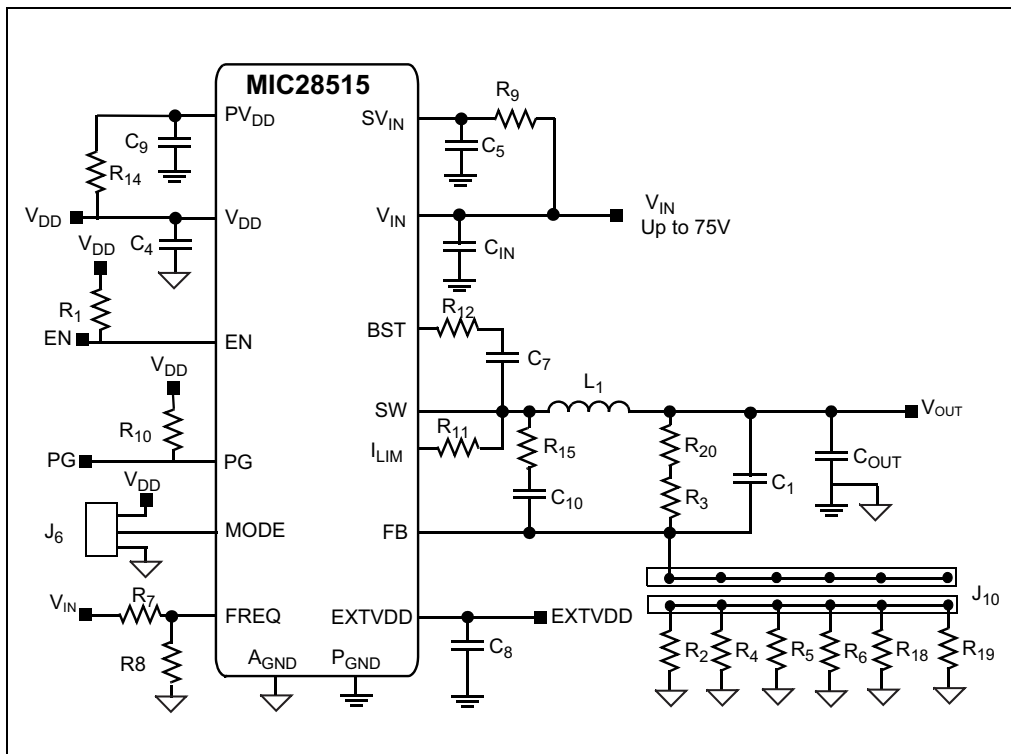

FIGURE 2-1: Evaluation Board Circuit Description.

2.3.1 Feedback Resistors

The output voltages available on the MIC28515 75V/5A HLL Step-Down Evaluation Board are: 0.8V, 1.2V, 2.5V, 3.3V, 5V and 12V, which are selectable using jumper J10.

Voltages other than the ones already available can be set by modifying the R_{bot} resistors according to Equation 2-1.

EQUATION 2-1:

$$R_{bot} = \frac{R_3 \times V_{REF}}{V_{OUT} - V_{REF}}$$

Where:

$$V_{REF} = 0.6V$$

$$R_3 = 10 \text{ k}\Omega$$

Note: The output voltage should not be set to exceed 15V due to the 16V voltage rating on the output capacitors. For output voltage higher than 15V, output capacitors of a voltage rating higher than the set output voltage should be used.

2.3.2 SW Node

Test point J2 (V_{SW}) is placed for monitoring the switching waveform, one of the most critical waveforms for the converter.

2.3.3 Current Limit

The MIC28515 75V/5A HLL Step-Down Evaluation Board uses the low-side MOSFET $R_{DS(ON)}$ to sense inductor current. In each switching cycle of the MIC28515 converter, the inductor current is sensed by monitoring the voltage across the low-side MOSFET, during the off period of the switching cycle, with the low-side MOSFET on. An internal current source of 135 μ A generates a voltage across the external Current-Limit Resistor, R_{CL} .

The I_{LIM} Pin Voltage (V_{ILIM}) is the difference of the voltage across the low-side MOSFET and the voltage across the resistor (V_{CL}). The sensed voltage, V_{ILIM} , is compared with the Power Ground (PGND) after a blanking time of 150 ns.

If the absolute value of the voltage drop across the low-side MOSFET is greater than the absolute value of the voltage across the current setting resistor (V_{CL}), the MIC28515 triggers the current-limit event. Consecutive eight current-limit events trigger the Hiccup mode. The hiccup sequence, including the Soft Start, reduces the stress on the internal MOSFETs, and protects the load and supply from severe short conditions.

The short-circuit current limit can be programmed by using the formula shown in [Equation 2-2](#).

EQUATION 2-2:

$$R_{II} = \frac{(I_{CLIM} + \Delta I_{LPP} \times 0.5) \times R_{DS(ON)}}{I_{CL}}$$

Where:

I_{CLIM} = Desired output current limit

ΔI_{LPP} = Inductor current peak-to-peak (usually 30% of the output current)

$R_{DS(ON)}$ = On resistance of low-side power MOSFET (25 m Ω)

I_{CL} = Current-limit source current, the typical value is 135 μ A

It is mandatory to make sure that the inductor current used to charge the output capacitance during Soft Start is under the current limit; otherwise, the supply will go into Hiccup mode and may not finish the Soft Start successfully.

The MOSFET $R_{DS(ON)}$ can vary up to 30%-40% with temperature. Therefore, it is recommended to add a 30% margin to the I_{CLIM} in the above equation to avoid false current limiting due to an increased MOSFET junction temperature rise.

2.3.4 Loop Gain Measurement

Resistor R20 is placed in series with the regulator feedback path. The control loop gain can be measured by connecting an impedance analyzer across the resistor and selecting the resistor value between 10 Ω to 50 Ω .

2.3.5 Setting the Switching Frequency

The MIC28515 75V/5A HLL Step-Down Evaluation Board is an adjustable frequency, synchronous buck converter featuring a unique adaptive on-time control architecture. The switching frequency can be adjusted between 270 kHz and 800 kHz by changing the resistor divider network consisting of R_7 and R_8 .

Equation 2-3 shows the estimated switching frequency:

EQUATION 2-3:

$$f_{SW} = f_0 \times \frac{R_8}{R_7 + R_8}$$

Where:

f_0 = Switching Frequency when FREQ pin is connected to the input voltage, f_0 is typically 800 kHz

The evaluation board design is optimized for a switching frequency of 300 kHz. If the switching frequency is programmed to either the lower end or the higher end, the design needs optimization.

2.3.6 MODE selection pin

In Continuous Conduction Mode (CCM), the inductor current can go negative at light loads. However, at light loads the MIC28515 is able to force the inductor current to operate in discontinuous mode when MODE is set to HLL mode. In HLL mode, the efficiency is optimized by shutting down all the nonessential circuits and minimizing the supply current. Jumper J6 can be used to select between the two modes of operation (MODE = V_{DD} for CCM or MODE = GND for HLL).

2.3.7 Auxiliary Bootstrap LDO (EXTVDD)

The MIC28515 75V/5A HLL Step-Down Evaluation Board features an auxiliary bootstrap LDO which improves the system efficiency by supplying the MIC28515 internal circuit bias power from the converter output voltage. This LDO is enabled when the voltage on the EXTVDD pin is above 4.6V (typical), and at the same time, the main LDO, which operates from V_{IN} , is disabled to reduce power consumption. If the regulator output voltage is $\geq 5V$ and $\leq 12V$, use the output voltage to power the MIC28515, which will increase system efficiency. The J1 jumper can be shorted to use the output voltage as EXTVDD.



MIC28515 75V/5A HLL STEP-DOWN EVALUATION BOARD USER'S GUIDE

Appendix A. Schematic and Layouts

A.1 INTRODUCTION

This appendix contains the following schematics and layouts for the MIC28515 75V/5A HLL Step-Down Evaluation Board:

- [Board – Schematic](#)
- [Board – Top Silk](#)
- [Board – Top Copper and Silk](#)
- [Board – Top Copper](#)
- [Board – MID Copper Layer 1](#)
- [Board – Mid Copper Layer 2](#)
- [Board – Bottom Copper](#)
- [Board – Bottom Copper and Silk](#)

A.2 BOARD – SCHEMATIC

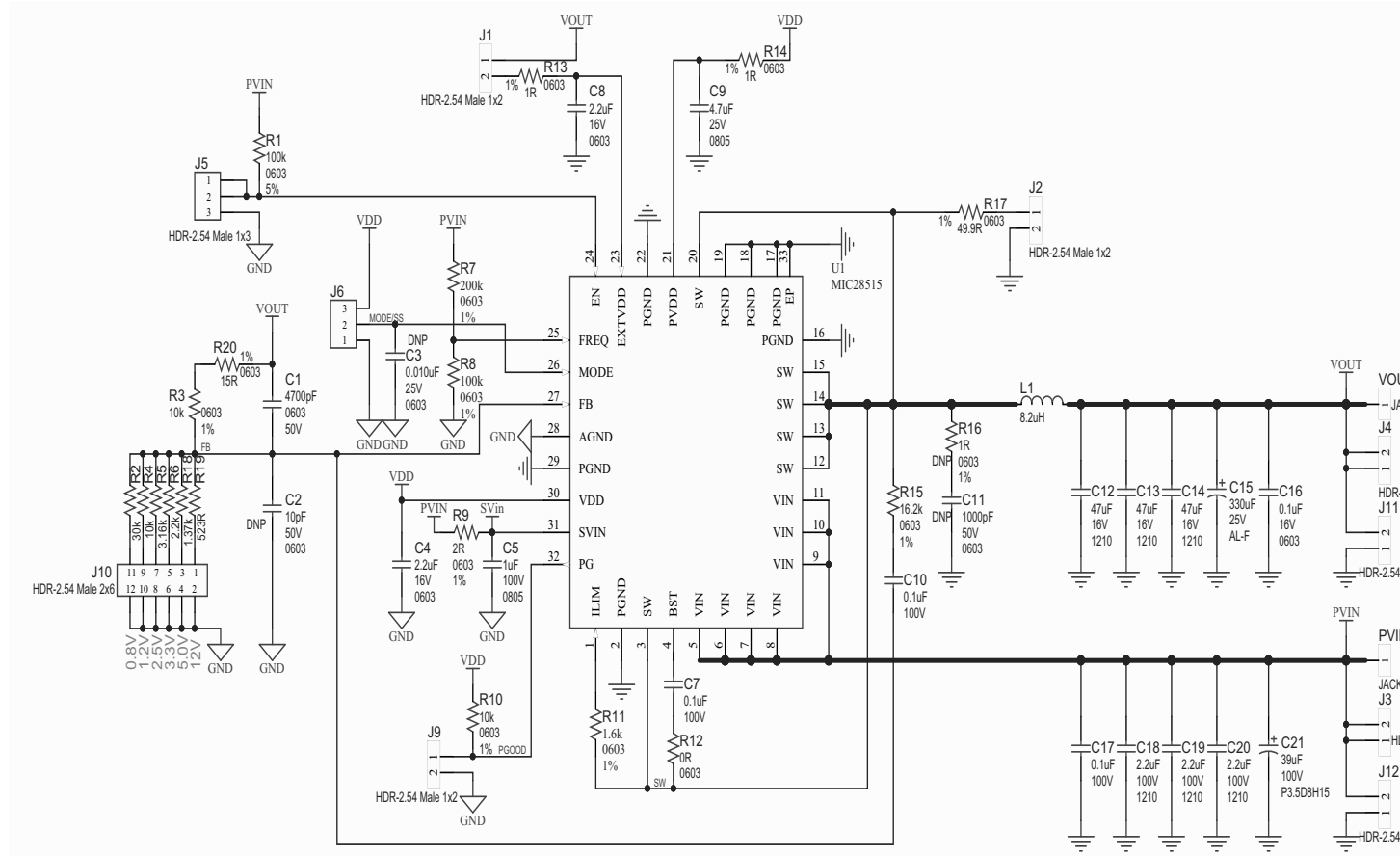

A.3 BOARD – TOP SILK

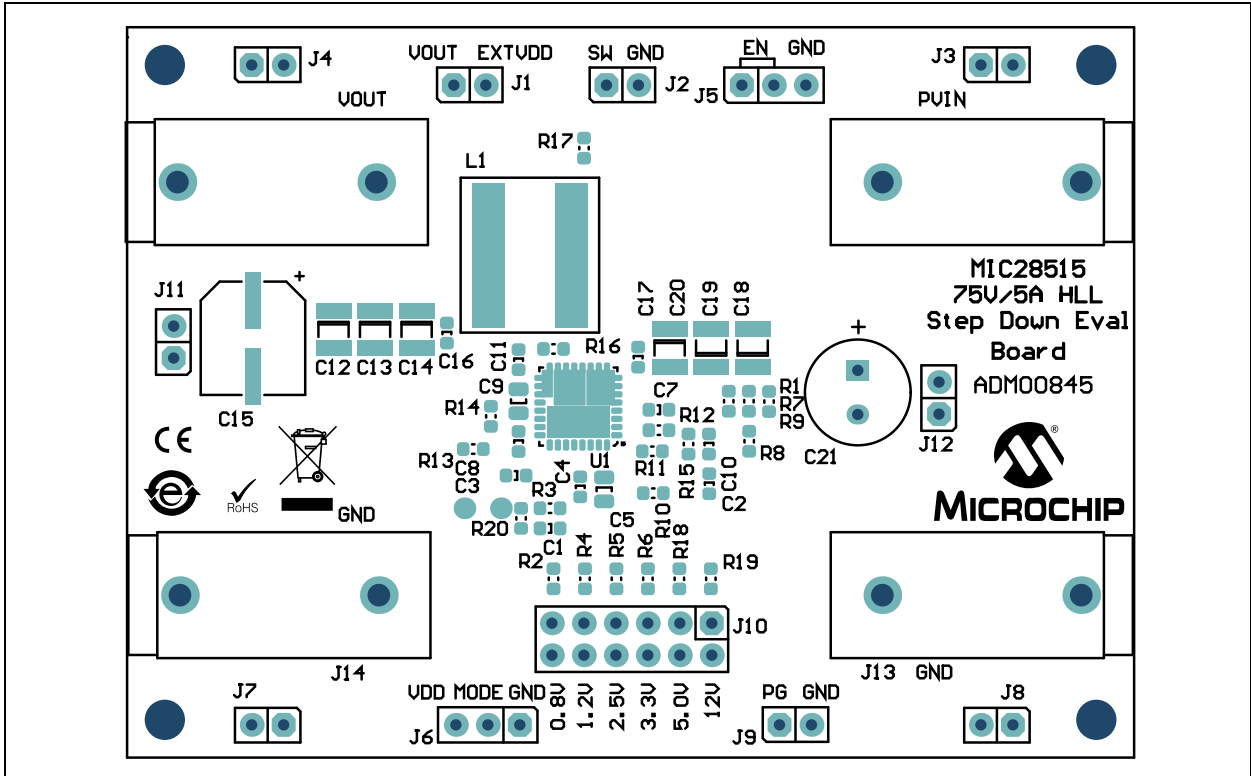

A.4 BOARD – TOP COPPER AND SILK

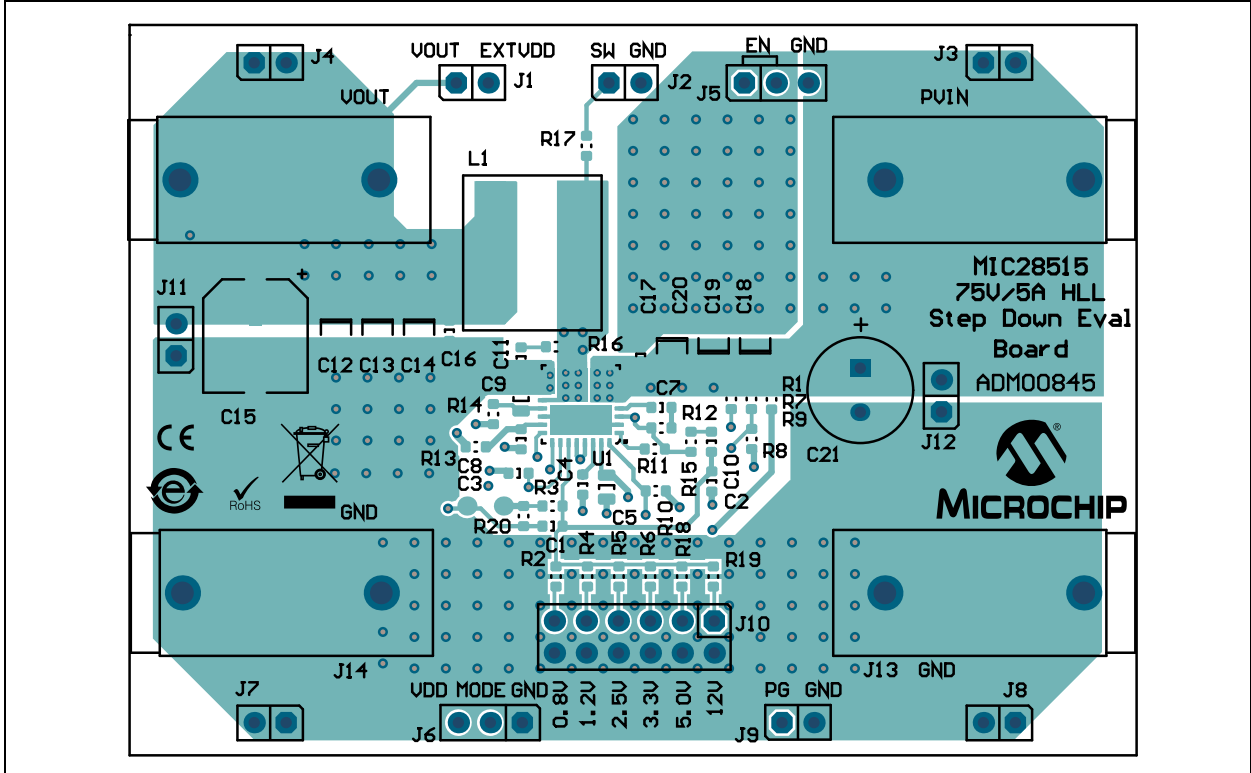

A.5 BOARD – TOP COPPER

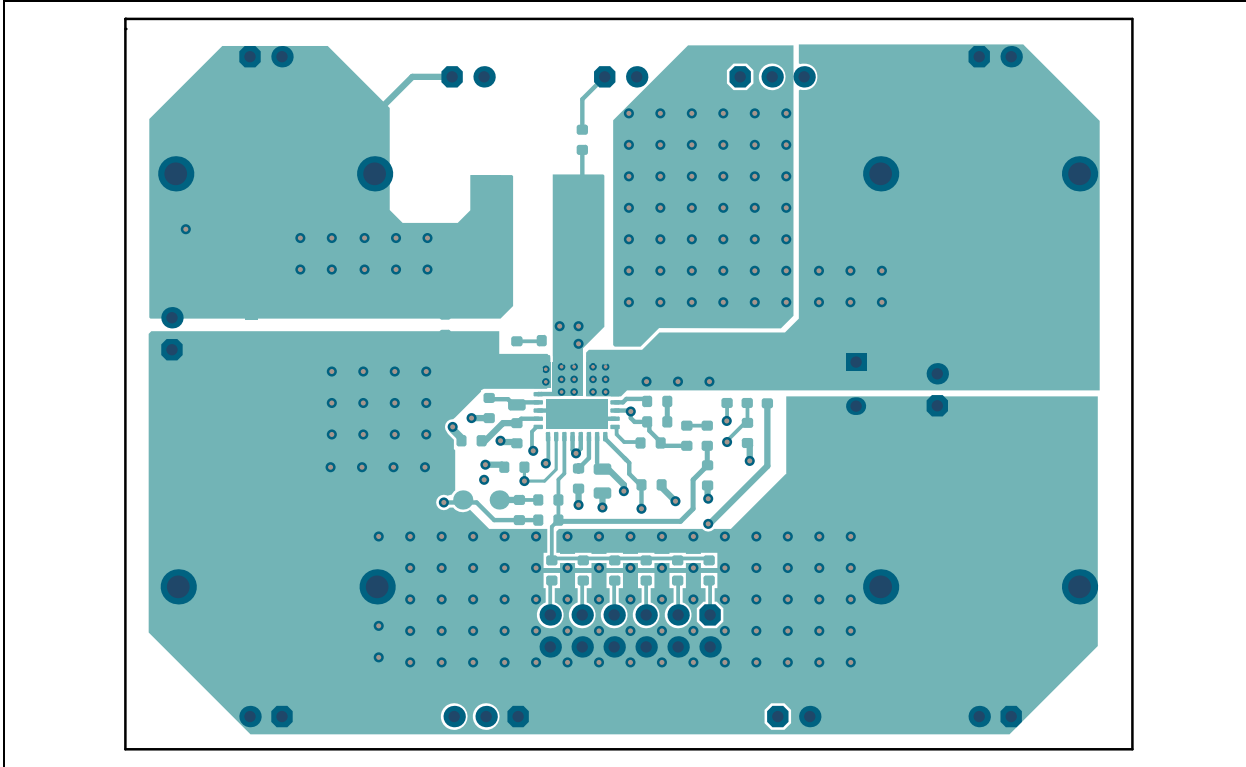

A.6 BOARD – MID COPPER LAYER 1

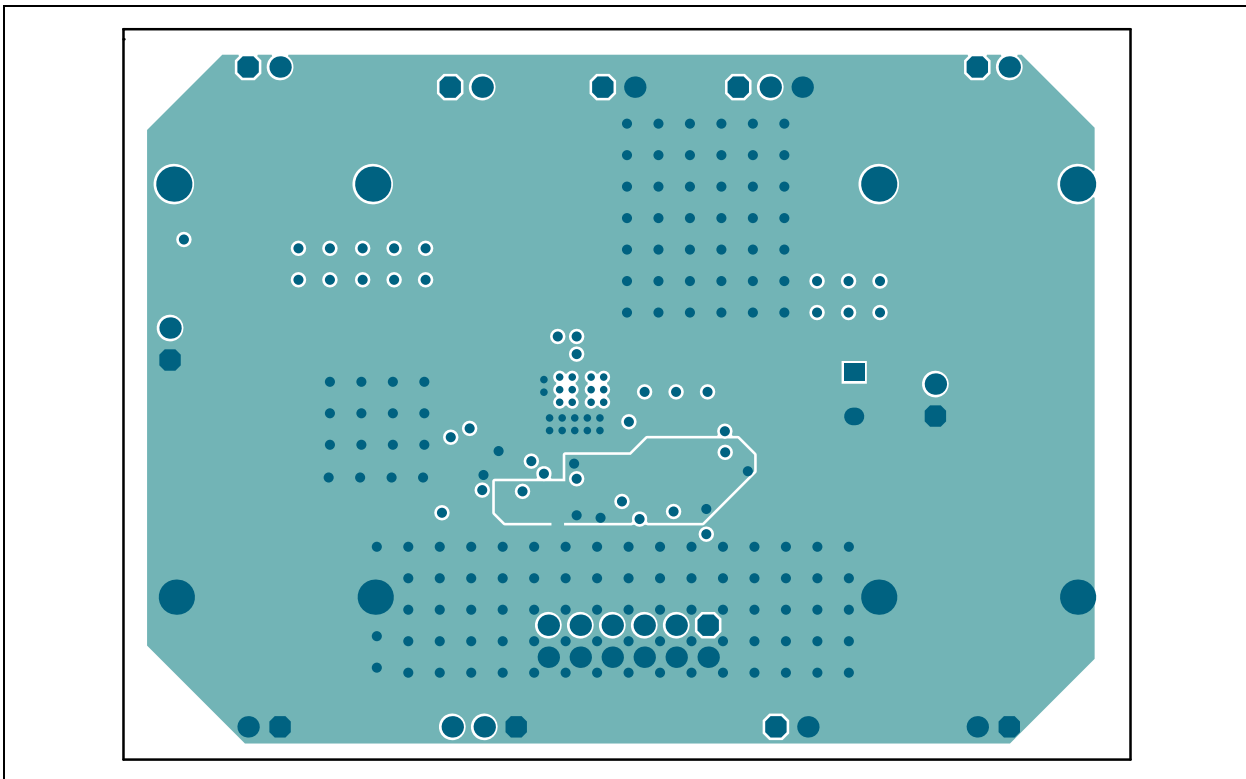

A.7 BOARD – MID COPPER LAYER 2

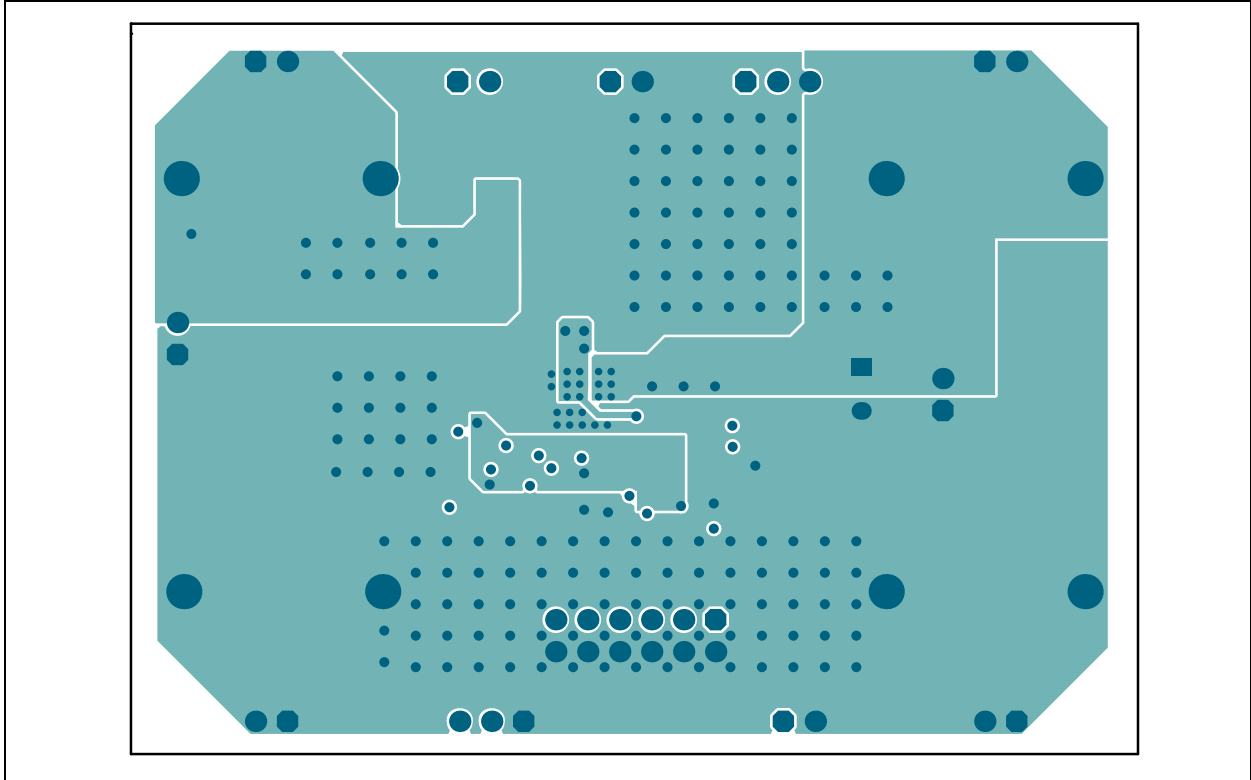

A.8 BOARD – BOTTOM COPPER

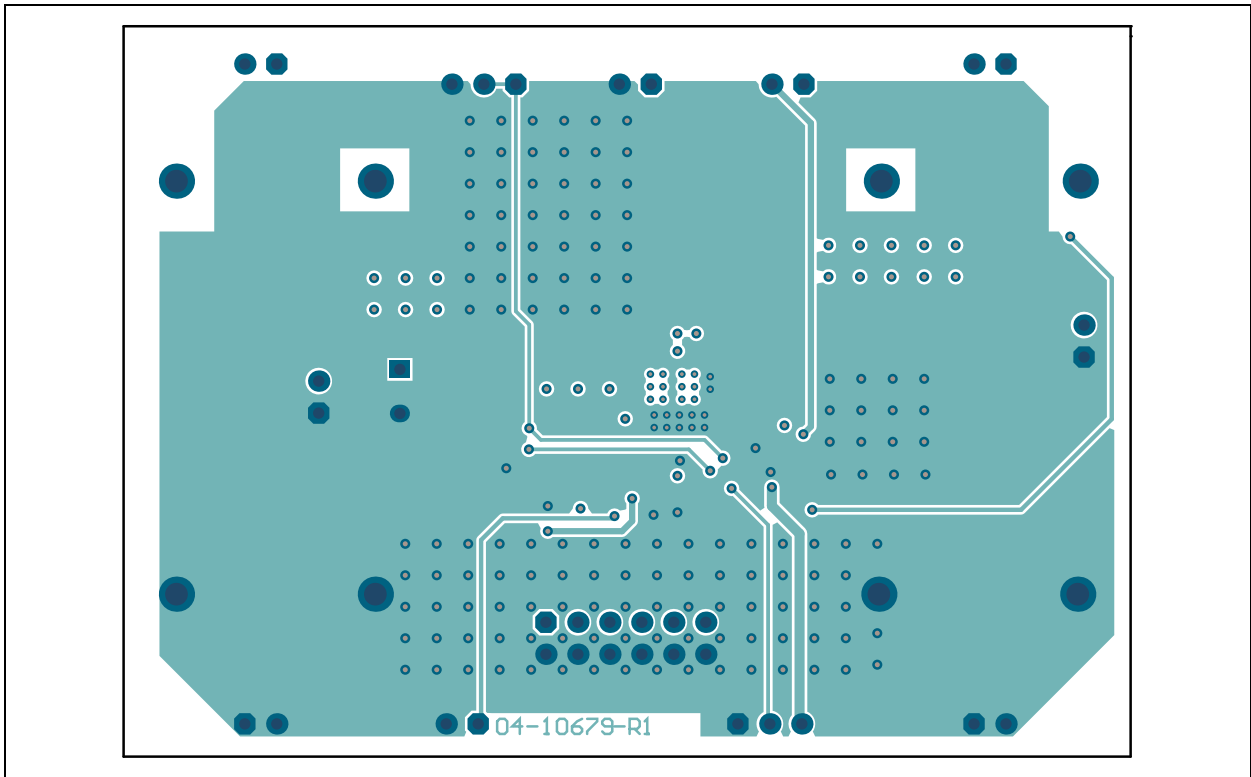

A.9 BOARD – BOTTOM COPPER AND SILK

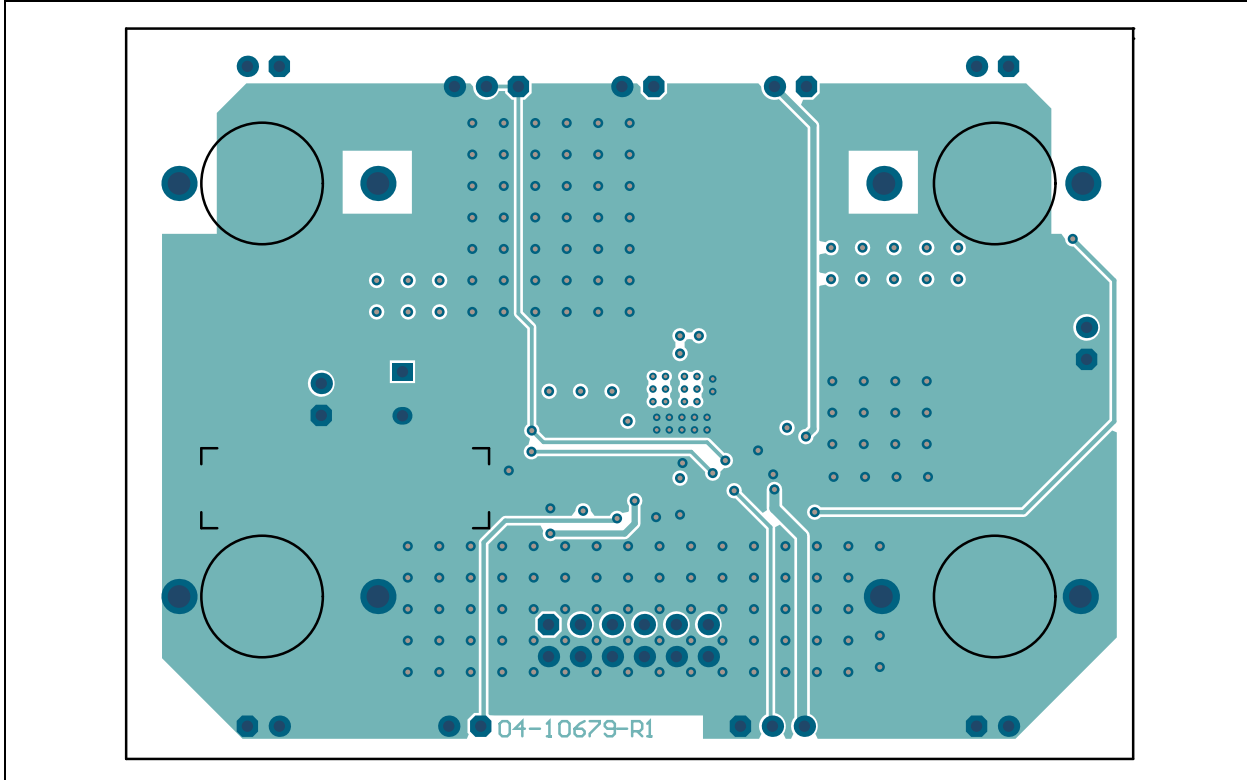



MIC28515 75V/5A HLL STEP-DOWN EVALUATION BOARD USER'S GUIDE

Appendix B. Bill of Materials (BOM)

TABLE B-1: BILL OF MATERIALS (BOM)

Qty.	Reference	Description	Manufacturer	Part Number
1	C1	Capacitor ceramic 4700 pF, 50V, 10%, X7R, SMD, 0603	KEMET	C0603C472K5RACTU
2	C4, C8	Capacitor ceramic, 2.2 μ F, 16V, 10%, X5R, SMD, 0603	TDK Corporation	C1608X5R1C225K
1	C5	Capacitor ceramic, 1 μ F, 100V, 10%, X7S, SMD, 0805	TDK Corporation	C2012X7S2A105K125AB
3	C7, C10, C17	Capacitor ceramic, 0.1 μ F, 100V, 10%, X7R, SMD, 0603	Murata Electronics North America, Inc.	GRM188R72A104KA35D
1	C9	Capacitor ceramic, 4.7 μ F, 25V, 20%, Y5V, SMD, 0805	TDK Corporation	C2012Y5V1E475Z
3	C12, C13, C14	Capacitor ceramic, 47 μ F, 16V, 20%, X5R, SMD, 1210	Yageo Corporation	CC1210MKX5R7BB476
1	C15	Capacitor aluminum. 330 μ F, 25V, 20%, SMD, F	Nichicon Corporation	UWT1E331MNL1GS
1	C16	Capacitor ceramic, 0.1 μ F, 16V, 10%, X7R, SMD, 0603	AVX Corporation	0603YC104KAT2A
3	C18, C19, C20	Capacitor ceramic, 2.2 μ F, 100V, 10%, X7R, SMD, 1210	KEMET	C1210C225K1RACTU
1	C21	Capacitor aluminum, 39 μ F, 100V, 20%, RAD, P3.5D8H15	United Chemi-Con	EKZE101ELL390MH15D
9	J1, J2, J3, J4, J7, J8, J9, J11, J12	Connector header-2.54 male, 1x2, gold, 5.84MH, TH, vertical	FCI	77311-118-02LF
2	J5, J6	Connector header-2.54 male, 1x3, gold, 5.84MH, TH, vertical	FCI	68000-103HLF
1	J10	Connector header-2.54 male, 2x6, gold, 5.84MH, TH, vertical	Samtec, Inc.	TSW-106-07-G-D
2	J13, J14	Connector jack, banana, blue, female, 4.0 mm, TH, R/A	Multicomp Inc.	24.243.5
1	L1	Inductor, 8.2 μ H, 17.1A, 20%, SMD, L11.3W10H10	Coilcraft	XAL1010-822MEB
1	PCB1	MIC28515 75V/5A HLL Step-Down Evaluation Board Printed Circuit Board	Microchip Technology Inc.	04-10679-R1
2	PV _{IN} , V _{OUT}	Connector jack, banana, red, female, 4.0 mm, TH, R/A	Multicomp Inc.	24.243.1
1	R1	Resistor, TKF, 100 k Ω , 5%, 1/10W, SMD, 0603 (Don't Use, Duplicate, Use RSMT0026)	Panasonic® - ECG	ERJ-3GEYJ104V
1	R2	Resistor, TKF, 30 k Ω , 1%, 1/10W, SMD, 0603	Stackpole Electronics, Inc.	RMCF0603FT30K0

Note 1: The components listed in this Bill of Materials are representative of the PCB assembly. The released BOM used in manufacturing uses all RoHS-compliant components.

MIC28515 75V/5A HLL Step-Down Evaluation Board User's Guide

TABLE B-1: BILL OF MATERIALS (BOM)

Qty.	Reference	Description	Manufacturer	Part Number
3	R3, R4, R10	Resistor, TF, 10 k Ω , 1%, 1/8W, SMD, 0603	Vishay Beyschlag	MCT06030C1002FP500
1	R5	Resistor, TKF, 3.16 k Ω , 1%, 1/10W, SMD, 0603	Panasonic [®] - ECG	ERJ-3EKF3161V
1	R6	Resistor, TKF, 2.2 k Ω , 1%, 1/10W, SMD, 0603	Panasonic [®] - ECG	ERJ-3EKF2201V
1	R7	Resistor, TKF, 200 k Ω , 1%, 1/10W, SMD, 0603	Vishay Intertechnology, Inc.	CRCW0603200KFKEA
1	R8	Resistor, TF, 100 k Ω , 1%, 1/8W, SMD, 0603	Vishay Intertechnology, Inc.	MCT06030C1003FP500
1	R9	Resistor, TKF, 2R, 1%, 1/4W, SMD, 0603	Vishay/Dale	CRCW06032R00FKEAHP
1	R11	Resistor, SMD, 1.6 k Ω , 1%, 1/10W, 0603	Vishay/Dale	CRCW06031K60FKEA
1	R12	Resistor, TKF, 0R, 1/10W, SMD, 0603	Panasonic [®] - ECG	ERJ-3GSY0R00V
2	R13, R14	Resistor, TKF, 1R, 1%, 1/10W, SMD, 0603	Yageo Corporation	RC0603FR-071RL
1	R15	Resistor, TKF, 16.2 k Ω , 1%, 1/10W, SMD, 0603	Panasonic [®] - ECG	ERJ-3EKF1622V
1	R17	Resistor, TKF, 49.9R, 1%, 1/10W, SMD, 0603	Panasonic [®] - ECG	ERJ-3EKF49R9V
1	R18	Resistor, TKF, 1.37 k Ω , 1%, 1/10W, SMD, 0603	Yageo Corporation	RC0603FR-071K37L
1	R19	Resistor, TKF, 523R, 1%, 1/10W, SMD, 0603	Yageo Corporation	ERJ3EKF5230V
1	R20	Resistor, TKF, 15R, 1%, 1/16W, SMD, 0603	Stackpole Electronics, Inc.	RMCF0603FT15R0
1	U1	MCHP Analog Switcher, Buck, MIC28515T-E/PHA VQFN-32	Microchip Technology Inc.	MIC28515T-E/PHA

Note 1: The components listed in this Bill of Materials are representative of the PCB assembly. The released BOM used in manufacturing uses all RoHS-compliant components.

TABLE B-2: BILL OF MATERIALS (BOM) - DO NOT POPULATE PARTS

Qty.	Reference	Description	Manufacturer	Part Number
1	C2	Capacitor ceramic, 10 pF, 50V, 0.5 pF, C0G, SMD, 0603	TDK Corporation	C1608C0G1H100D
1	C3	Capacitor ceramic, 0.010 μ F, 25V, 10%, X7R, SMD, 0603	Yageo Corporation	CC0603KRX7R8BB103
1	C11	Capacitor ceramic, 1000 pF, 50V, 20%, X7R, SMD, 0603	KEMET	C0603C102M5RAC
1	R16	Resistor, TKF, 1R, 1%, 1/10W, SMD, 0603	Yageo Corporation	RC0603FR-071RL

Note 1: The components listed in this Bill of Materials are representative of the PCB assembly. The released BOM used in manufacturing uses all RoHS-compliant components.

TABLE B-3: BILL OF MATERIALS (BOM) - MECHANICAL PARTS

Qty.	Reference	Description	Manufacturer	Part Number
2	JP1, JP2	Mechanical hardware jumper, 2.54 mm, 1x2, handle gold	TE Connectivity, Ltd.	881545-2
4	PAD1, PAD2, PAD3, PAD4	Mechanical hardware, rubber pad, cylindrical, D9.53H5.97	3M	SJ61A2

Note 1: The components listed in this Bill of Materials are representative of the PCB assembly. The released BOM used in manufacturing uses all RoHS-compliant components.



MICROCHIP

Worldwide Sales and Service

AMERICAS

Corporate Office

2355 West Chandler Blvd.
Chandler, AZ 85224-6199
Tel: 480-792-7200
Fax: 480-792-7277
Technical Support:
[http://www.microchip.com/
support](http://www.microchip.com/support)

Web Address:

www.microchip.com

Atlanta

Duluth, GA
Tel: 678-957-9614
Fax: 678-957-1455

Austin, TX

Tel: 512-257-3370

Boston

Westborough, MA
Tel: 774-760-0087
Fax: 774-760-0088

Chicago

Itasca, IL
Tel: 630-285-0071
Fax: 630-285-0075

Dallas

Addison, TX
Tel: 972-818-7423
Fax: 972-818-2924

Detroit

Novi, MI
Tel: 248-848-4000

Houston, TX

Tel: 281-894-5983

Indianapolis

Noblesville, IN
Tel: 317-773-8323
Fax: 317-773-5453
Tel: 317-536-2380

Los Angeles

Mission Viejo, CA
Tel: 949-462-9523
Fax: 949-462-9608
Tel: 951-273-7800

Raleigh, NC

Tel: 919-844-7510

New York, NY

Tel: 631-435-6000

San Jose, CA

Tel: 408-735-9110
Tel: 408-436-4270

Canada - Toronto

Tel: 905-695-1980
Fax: 905-695-2078

ASIA/PACIFIC

Asia Pacific Office

Suites 3707-14, 37th Floor
Tower 6, The Gateway
Harbour City, Kowloon

Hong Kong

Tel: 852-2943-5100
Fax: 852-2401-3431

Australia - Sydney

Tel: 61-2-9868-6733
Fax: 61-2-9868-6755

China - Beijing

Tel: 86-10-8569-7000
Fax: 86-10-8528-2104

China - Chengdu

Tel: 86-28-8665-5511
Fax: 86-28-8665-7889

China - Chongqing

Tel: 86-23-8980-9588
Fax: 86-23-8980-9500

China - Dongguan

Tel: 86-769-8702-9880

China - Guangzhou

Tel: 86-20-8755-8029

China - Hangzhou

Tel: 86-571-8792-8115
Fax: 86-571-8792-8116

China - Hong Kong SAR

Tel: 852-2943-5100
Fax: 852-2401-3431

China - Nanjing

Tel: 86-25-8473-2460
Fax: 86-25-8473-2470

China - Qingdao

Tel: 86-532-8502-7355
Fax: 86-532-8502-7205

China - Shanghai

Tel: 86-21-3326-8000
Fax: 86-21-3326-8021

China - Shenyang

Tel: 86-24-2334-2829
Fax: 86-24-2334-2393

China - Shenzhen

Tel: 86-755-8864-2200
Fax: 86-755-8203-1760

China - Wuhan

Tel: 86-27-5980-5300
Fax: 86-27-5980-5118

China - Xian

Tel: 86-29-8833-7252
Fax: 86-29-8833-7256

ASIA/PACIFIC

China - Xiamen

Tel: 86-592-2388138
Fax: 86-592-2388130

China - Zhuhai

Tel: 86-756-3210040
Fax: 86-756-3210049

India - Bangalore

Tel: 91-80-3090-4444
Fax: 91-80-3090-4123

India - New Delhi

Tel: 91-11-4160-8631
Fax: 91-11-4160-8632

India - Pune

Tel: 91-20-3019-1500

Japan - Osaka

Tel: 81-6-6152-7160
Fax: 81-6-6152-9310

Japan - Tokyo

Tel: 81-3-6880-3770
Fax: 81-3-6880-3771

Korea - Daegu

Tel: 82-53-744-4301
Fax: 82-53-744-4302

Korea - Seoul

Tel: 82-2-554-7200
Fax: 82-2-558-5932 or
82-2-558-5934

Malaysia - Kuala Lumpur

Tel: 60-3-6201-9857
Fax: 60-3-6201-9859

Malaysia - Penang

Tel: 60-4-227-8870
Fax: 60-4-227-4068

Philippines - Manila

Tel: 63-2-634-9065
Fax: 63-2-634-9069

Singapore

Tel: 65-6334-8870
Fax: 65-6334-8850

Taiwan - Hsin Chu

Tel: 886-3-5778-366
Fax: 886-3-5770-955

Taiwan - Kaohsiung

Tel: 886-7-213-7830

Taiwan - Taipei

Tel: 886-2-2508-8600
Fax: 886-2-2508-0102

Thailand - Bangkok

Tel: 66-2-694-1351
Fax: 66-2-694-1350

EUROPE

Austria - Wels

Tel: 43-7242-2244-39
Fax: 43-7242-2244-393

Denmark - Copenhagen

Tel: 45-4450-2828
Fax: 45-4485-2829

Finland - Espoo

Tel: 358-9-4520-820

France - Paris

Tel: 33-1-69-53-63-20
Fax: 33-1-69-30-90-79

France - Saint Cloud

Tel: 33-1-30-60-70-00

Germany - Garching

Tel: 49-8931-9700

Germany - Haan

Tel: 49-2129-3766400

Germany - Heilbronn

Tel: 49-7131-67-3636

Germany - Karlsruhe

Tel: 49-721-625370

Germany - Munich

Tel: 49-89-627-144-0
Fax: 49-89-627-144-44

Germany - Rosenheim

Tel: 49-8031-354-560

Israel - Ra'anana

Tel: 972-9-744-7705

Italy - Milan

Tel: 39-0331-742611
Fax: 39-0331-466781

Italy - Padova

Tel: 39-049-7625286

Netherlands - Drunen

Tel: 31-416-690399
Fax: 31-416-690340

Norway - Trondheim

Tel: 47-7289-7561

Poland - Warsaw

Tel: 48-22-3325737

Romania - Bucharest

Tel: 40-21-407-87-50

Spain - Madrid

Tel: 34-91-708-08-90
Fax: 34-91-708-08-91

Sweden - Gothenberg

Tel: 46-31-704-60-40

Sweden - Stockholm

Tel: 46-8-5090-4654

UK - Wokingham

Tel: 44-118-921-5800
Fax: 44-118-921-5820

X-ON Electronics

Largest Supplier of Electrical and Electronic Components

Click to view similar products for [Power Management IC Development Tools](#) category:

Click to view products by [Microchip](#) manufacturer:

Other Similar products are found below :

[EVB-EP5348UI](#) [MIC23451-AAAYFL EV](#) [MIC5281YMME EV](#) [124352-HMC860LP3E](#) [DA9063-EVAL](#) [ADP122-3.3-EVALZ](#) [ADP130-0.8-EVALZ](#) [ADP130-1.8-EVALZ](#) [ADP1740-1.5-EVALZ](#) [ADP1870-0.3-EVALZ](#) [ADP1874-0.3-EVALZ](#) [ADP199CB-EVALZ](#) [ADP2102-1.25-EVALZ](#) [ADP2102-1.875EVALZ](#) [ADP2102-1.8-EVALZ](#) [ADP2102-2-EVALZ](#) [ADP2102-3-EVALZ](#) [ADP2102-4-EVALZ](#) [AS3606-DB](#) [BQ25010EVM](#) [BQ3055EVM](#) [ISLUSBI2CKIT1Z](#) [LP38512TS-1.8EV](#) [EVAL-ADM1186-1MBZ](#) [EVAL-ADM1186-2MBZ](#) [ADP122UJZ-REDYKIT](#) [ADP166Z-REDYKIT](#) [ADP170-1.8-EVALZ](#) [ADP171-EVALZ](#) [ADP1853-EVALZ](#) [ADP1873-0.3-EVALZ](#) [ADP198CP-EVALZ](#) [ADP2102-1.0-EVALZ](#) [ADP2102-1-EVALZ](#) [ADP2107-1.8-EVALZ](#) [ADP5020CP-EVALZ](#) [CC-ACC-DBMX-51](#) [ATPL230A-EK](#) [MIC23250-S4YMT EV](#) [MIC26603YJL EV](#) [MIC33050-SYHL EV](#) [TPS60100EVM-131](#) [TPS65010EVM-230](#) [TPS71933-28EVM-213](#) [TPS72728YFFEVM-407](#) [TPS79318YEQEVM](#) [UCC28810EVM-002](#) [XILINXPWR-083](#) [LMR22007YMINI-EVM](#) [LP38501ATJ-EV](#)