



MICROCHIP

MIC2800
Evaluation Board
User's Guide

Note the following details of the code protection feature on Microchip devices:

- Microchip products meet the specification contained in their particular Microchip Data Sheet.
- Microchip believes that its family of products is one of the most secure families of its kind on the market today, when used in the intended manner and under normal conditions.
- There are dishonest and possibly illegal methods used to breach the code protection feature. All of these methods, to our knowledge, require using the Microchip products in a manner outside the operating specifications contained in Microchip's Data Sheets. Most likely, the person doing so is engaged in theft of intellectual property.
- Microchip is willing to work with the customer who is concerned about the integrity of their code.
- Neither Microchip nor any other semiconductor manufacturer can guarantee the security of their code. Code protection does not mean that we are guaranteeing the product as "unbreakable."

Code protection is constantly evolving. We at Microchip are committed to continuously improving the code protection features of our products. Attempts to break Microchip's code protection feature may be a violation of the Digital Millennium Copyright Act. If such acts allow unauthorized access to your software or other copyrighted work, you may have a right to sue for relief under that Act.

Information contained in this publication regarding device applications and the like is provided only for your convenience and may be superseded by updates. It is your responsibility to ensure that your application meets with your specifications. MICROCHIP MAKES NO REPRESENTATIONS OR WARRANTIES OF ANY KIND WHETHER EXPRESS OR IMPLIED, WRITTEN OR ORAL, STATUTORY OR OTHERWISE, RELATED TO THE INFORMATION, INCLUDING BUT NOT LIMITED TO ITS CONDITION, QUALITY, PERFORMANCE, MERCHANTABILITY OR FITNESS FOR PURPOSE. Microchip disclaims all liability arising from this information and its use. Use of Microchip devices in life support and/or safety applications is entirely at the buyer's risk, and the buyer agrees to defend, indemnify and hold harmless Microchip from any and all damages, claims, suits, or expenses resulting from such use. No licenses are conveyed, implicitly or otherwise, under any Microchip intellectual property rights unless otherwise stated.

Microchip received ISO/TS-16949:2009 certification for its worldwide headquarters, design and wafer fabrication facilities in Chandler and Tempe, Arizona; Gresham, Oregon and design centers in California and India. The Company's quality system processes and procedures are for its PIC® MCUs and dsPIC® DSCs, KEELOQ® code hopping devices, Serial EEPROMs, microperipherals, nonvolatile memory and analog products. In addition, Microchip's quality system for the design and manufacture of development systems is ISO 9001:2000 certified.

**QUALITY MANAGEMENT SYSTEM
CERTIFIED BY DNV
= ISO/TS 16949 =**

Trademarks

The Microchip name and logo, the Microchip logo, AnyRate, AVR, AVR logo, AVR Freaks, BeaconThings, BitCloud, CryptoMemory, CryptoRF, dsPIC, FlashFlex, flexPWR, Helder, JukeBlox, KEELOQ, KEELOQ logo, Klear, LANCheck, LINK MD, maXStylus, maXTouch, MediaLB, megaAVR, MOST, MOST logo, MPLAB, OptoLyzer, PIC, picoPower, PICSTART, PIC32 logo, Prochip Designer, QTouch, RightTouch, SAM-BA, SpyNIC, SST, SST Logo, SuperFlash, tinyAVR, UNI/O, and XMEGA are registered trademarks of Microchip Technology Incorporated in the U.S.A. and other countries.

ClockWorks, The Embedded Control Solutions Company, EtherSynch, Hyper Speed Control, HyperLight Load, IntelliMOS, mTouch, Precision Edge, and Quiet-Wire are registered trademarks of Microchip Technology Incorporated in the U.S.A.

Adjacent Key Suppression, AKS, Analog-for-the-Digital Age, Any Capacitor, AnyIn, AnyOut, BodyCom, chipKIT, chipKIT logo, CodeGuard, CryptoAuthentication, CryptoCompanion, CryptoController, dsPICDEM, dsPICDEM.net, Dynamic Average Matching, DAM, ECAN, EtherGREEN, In-Circuit Serial Programming, ICSP, Inter-Chip Connectivity, JitterBlocker, KlearNet, KlearNet logo, Mindi, MiWi, motorBench, MPASM, MPF, MPLAB Certified logo, MPLIB, MPLINK, MultiTRAK, NetDetach, Omniscient Code Generation, PICDEM, PICDEM.net, PICkit, PICTail, PureSilicon, QMatrix, RightTouch logo, REAL ICE, Ripple Blocker, SAM-ICE, Serial Quad I/O, SMART-I.S., SQI, SuperSwitcher, SuperSwitcher II, Total Endurance, TSHARC, USBCheck, VariSense, ViewSpan, WiperLock, Wireless DNA, and ZENA are trademarks of Microchip Technology Incorporated in the U.S.A. and other countries.

SQTP is a service mark of Microchip Technology Incorporated in the U.S.A.

Silicon Storage Technology is a registered trademark of Microchip Technology Inc. in other countries.

GestIC is a registered trademark of Microchip Technology Germany II GmbH & Co. KG, a subsidiary of Microchip Technology Inc., in other countries.

All other trademarks mentioned herein are property of their respective companies.

© 2017, Microchip Technology Incorporated, All Rights Reserved.
ISBN: 978-1-5224-2361-4

Table of Contents

Preface	6
Introduction.....	6
Document Layout	6
Conventions Used in this Guide	7
Warranty Registration.....	7
Recommended Reading.....	8
The Microchip Web Site	8
Product Change Notification Service.....	8
Customer Support	8
Document Revision History	8
Chapter 1. Product Overview	
1.1 Introduction	10
1.2 MIC2800 Device Short Overview	10
1.3 MIC2800 Evaluation Board Overview	11
1.4 MIC2800 Evaluation Board Kit Contents	12
Chapter 2. Installation and Operation	
2.1 Introduction	14
2.2 Getting Started	14
2.3 Evaluation Board Description	15
Appendix A. Schematic and Layouts	
A.1 Introduction	18
A.2 Board – Schematic	19
A.3 Board – Top Silk	20
A.4 Board – Top Copper and Silk	21
A.5 Board – Top Copper	22
A.6 Board – Bottom Copper	23
A.7 Board – Bottom Copper and Silk	24
A.8 Board – Bottom Silk	25
Appendix B. Bill of Materials (BOM)	26
Worldwide Sales and Service	28

MIC2800 Evaluation Board User's Guide

NOTES:

Preface

NOTICE TO CUSTOMERS

All documentation becomes dated, and this manual is no exception. Microchip tools and documentation are constantly evolving to meet customer needs, so some actual dialogs and/or tool descriptions may differ from those in this document. Please refer to our website (www.microchip.com) to obtain the latest documentation available.

Documents are identified with a “DS” number. This number is located on the bottom of each page, in front of the page number. The numbering convention for the DS number is “DSXXXXXXXXA”, where “XXXXXXXX” is the document number and “A” is the revision level of the document.

For the most up-to-date information on development tools, see the MPLAB® IDE online help. Select the Help menu, and then Topics, to open a list of available online help files.

INTRODUCTION

This chapter contains general information that will be useful to know before using the MIC2800 Evaluation Board. Items discussed in this chapter include:

- [Document Layout](#)
- [Conventions Used in this Guide](#)
- [Warranty Registration](#)
- [Recommended Reading](#)
- [The Microchip Web Site](#)
- [Customer Support](#)
- [Document Revision History](#)

DOCUMENT LAYOUT

This document describes how to use the MIC2800 Evaluation Board as a development tool to emulate and debug firmware on a target board. The manual layout is as follows:

- **Chapter 1. “Product Overview”** – Important information about the MIC2800 Evaluation Board.
- **Chapter 2. “Installation and Operation”** – Includes instructions on installing and starting the Microchip Chip Manager application.
- **Appendix A. “Schematic and Layouts”** – Shows the schematic and layout diagrams for the MIC2800 Evaluation Board.
- **Appendix B. “Bill of Materials (BOM)”** – Lists the parts used to build the MIC2800 Evaluation Board.

MIC2800 Evaluation Board User's Guide

CONVENTIONS USED IN THIS GUIDE

This manual uses the following documentation conventions:

DOCUMENTATION CONVENTIONS

Description	Represents	Examples
Arial font:		
Italic characters	Referenced books	<i>MPLAB® IDE User's Guide</i>
	Emphasized text	...is the <i>only</i> compiler...
Initial caps	A window	the Output window
	A dialog	the Settings dialog
	A menu selection	select Enable Programmer
Quotes	A field name in a window or dialog	"Save project before build"
Underlined, italic text with right angle bracket	A menu path	<u><i>File</i></u> >Save
Bold characters	A dialog button	Click OK
	A tab	Click the Power tab
N'Rnnnn	A number in verilog format, where N is the total number of digits, R is the radix and n is a digit.	4'b0010, 2'hF1
Text in angle brackets < >	A key on the keyboard	Press <Enter>, <F1>
Courier New font:		
Plain Courier New	Sample source code	#define START
	Filenames	autoexec.bat
	File paths	c:\mcc18\h
	Keywords	_asm, _endasm, static
	Command-line options	-Opa+, -Opa-
	Bit values	0, 1
	Constants	0xFF, 'A'
Italic Courier New	A variable argument	<i>file.o</i> , where <i>file</i> can be any valid filename
Square brackets []	Optional arguments	mcc18 [options] <i>file</i> [options]
Curly brackets and pipe character: { }	Choice of mutually exclusive arguments; an OR selection	errorlevel {0 1}
Ellipses...	Replaces repeated text	var_name [, var_name...]
	Represents code supplied by user	void main (void) { ... }

RECOMMENDED READING

This user's guide describes how to use the MIC2800 Evaluation Board. Another useful document is listed below. The following Microchip document is available and recommended as a supplemental reference resource:

MIC2800 Data Sheet – “Digital Power Management IC 2 MHz, 600 mA DC/DC with Dual 300 mA/300 mA Low V_{IN} LDOs” (DS20005839A)

THE MICROCHIP WEB SITE

Microchip provides online support via our web site at www.microchip.com. This web site is used as a means to make files and information easily available to customers. Accessible by using your favorite Internet browser, the web site contains the following information:

- **Product Support** – Data sheets and errata, application notes and sample programs, design resources, user's guides and hardware support documents, latest software releases and archived software
- **General Technical Support** – Frequently Asked Questions (FAQs), technical support requests, online discussion groups, Microchip consultant program member listing
- **Business of Microchip** – Product selector and ordering guides, latest Microchip press releases, listing of seminars and events, listings of Microchip sales offices, distributors and factory representatives

PRODUCT CHANGE NOTIFICATION SERVICE

Microchip's customer notification service helps keep customers current on Microchip products. Subscribers will receive email notifications whenever there are changes, updates, revisions or errata related to a specified product family or development tool of interest.

To register, access the Microchip web site at www.microchip.com, click on **Product Change Notification** and follow the registration instructions.

CUSTOMER SUPPORT

Users of Microchip products can receive assistance through several channels:

- Distributor or Representative
- Local Sales Office
- Field Application Engineer (FAE)
- Technical Support

Customers should contact their distributor, representative or field application engineer (FAE) for support. Local sales offices are also available to help customers. A listing of sales offices and locations is included in the back of this document.

Technical support is available through the web site at:
<http://www.microchip.com/support>

DOCUMENT REVISION HISTORY

Revision A (November 2017)

- Initial Release of this Document.

MIC2800 Evaluation Board User's Guide

NOTES:

Chapter 1. Product Overview

1.1 INTRODUCTION

This chapter provides an overview of the MIC2800 Evaluation Board and covers the following topics:

- [MIC2800 Device Short Overview](#)
- [MIC2800 Evaluation Board Overview](#)
- [MIC2800 Evaluation Board Kit Contents](#)

1.2 MIC2800 DEVICE SHORT OVERVIEW

1.2.1 MIC2800 Key Features

The key features of the MIC2800 include:

- 2.7V to 5.5V input voltage range
- 2 MHz DC/DC converter and two LDOs
 - LDO1 is powered from DC/DC converter for highest efficiency
 - LDO2 is powered directly from V_{IN}
- Integrated power-on reset (AND function for all outputs)
- Adjustable delay time
- LOWQ mode for DC/DC and LDOs
- 30 μ A Total I_Q when in LOWQ mode
- Thermal Shutdown Protection
- Current Limit Protection
- Tiny 16-pin 3 mm x 3 mm QFN package

DC to DC Converter

- Output current to 600 mA in PWM mode
- LOWQ Mode: NO NOISE Light load mode
- 75 μ V_{RMS} output noise in LOWQ mode
- 2 MHz PWM operation in normal mode
- >90% efficiency

LDOs

- LDO1: input voltage directly connected to DC/DC converter output voltage for maximum efficiency
 - Ideal for 1.8V to 1.5V conversion
 - 300 mA output current from 1.8V input
 - Output voltage down to 0.8V
- LDO2: 300 mA output current capable

MIC2800 Evaluation Board User's Guide

1.2.2 MIC2800 Device Overview

The MIC2800 device is a high-performance power management IC, giving three output voltages with maximum efficiency. Combining a 2 MHz DC/DC converter with an LDO regulator (LDO1), the MIC2800 gives two high-efficiency outputs (DC/DC and LDO1), combined with the flexibility of a third output, a 300 mA LDO (LDO2). The MIC2800 features a LOWQ mode, reducing the total current draw in this mode to less than 30 μA . In LOWQ mode, the output noise of the DC to DC converter is 75 μV_{RMS} , significantly lower than other converters which use a PFM light load mode that can interfere with sensitive RF circuitry.

The DC to DC converter uses small values of the inductor and capacitors to reduce board space, but still retains efficiencies over 90%, at load currents up to 600 mA.

The MIC2800 is a μCap design, operating with very small ceramic output capacitors and inductors for stability, reducing required board space and component cost and it is available in fixed output voltages in the 16-pin 3 mm x 3 mm QFN lead-free package.

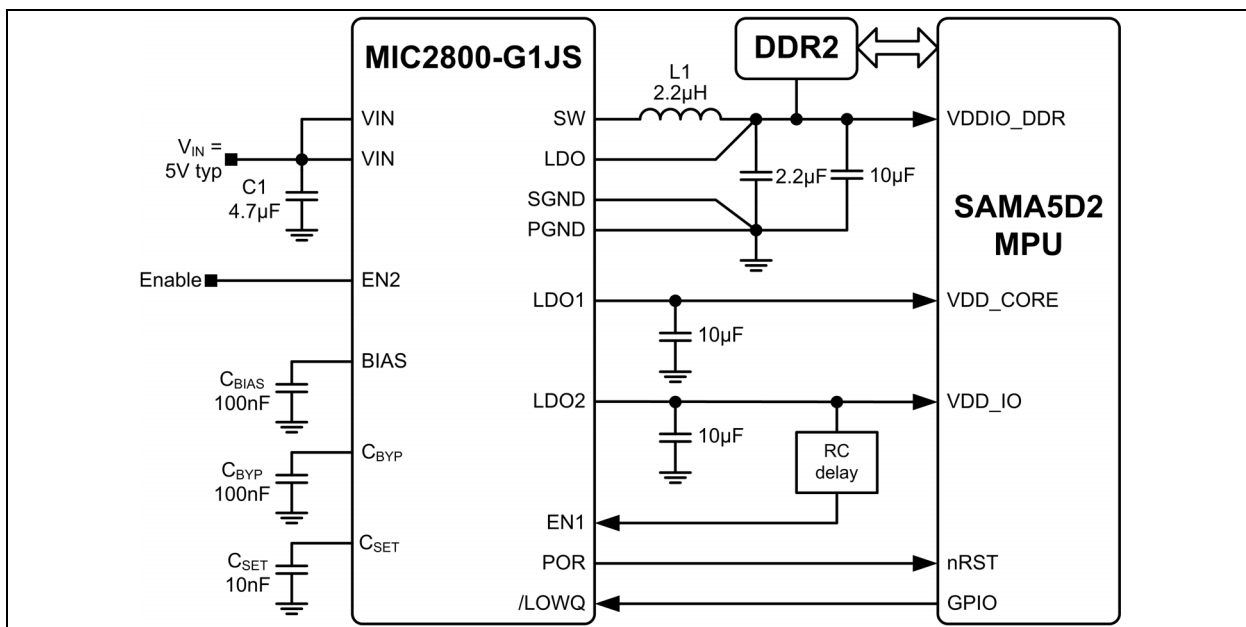

FIGURE 1-1: MIC2800 Typical Application Circuit.

1.3 MIC2800 EVALUATION BOARD OVERVIEW

The MIC2800 Evaluation Board has been developed to evaluate the capabilities of the MIC2800 multi-output (DC-DC and 2 x LDO) device. The board is populated with the MIC2800-G1JS device and it is set to the following voltages:

- VOUT1 (DC-DC Buck converter): 1.8V
- VOUT2 (LDO1): 1.25V
- VOUT3 (LDO2): 3.3V

The MIC2800-G1JS allows support of the SAMA5D2 family MPUs when operating off a 5V input rail. However, by populating the board with another MIC2800 IC voltage option, other power supply solutions can be demonstrated.

The MIC2800 Evaluation Board features independent Enable connectors (EN1 and EN2). To disable the regulators, a jumper must be placed on J1 (to disable the DC/DC converter and LDO1) or to J2 (to disable LDO2). Since it is not recommended to leave EN pins floating, the MIC2800 Evaluation Board features 100 k Ω pull-up resistors, so the default value when the board is powered is ON.

The MIC2800 Evaluation Board also features a $\overline{\text{LOWQ}}$ pin to switch the functionality of the DC/DC converter. When the $\overline{\text{LOWQ}}$ is logic high ($>1\text{V}$), the DC/DC converter works in PWM mode (normal operation mode with 600 mA output current capability). When the $\overline{\text{LOWQ}}$ is logic low ($<0.2\text{V}$), the DC/DC converter stops switching, the output voltage is supplied by a low noise linear regulator and the quiescent current of the device is greatly reduced. In linear (LDO) mode, the DC/DC converter output can deliver 60 mA of current to the load from the LDO pin.

The $\overline{\text{LOWQ}}$ mode also limits the output load of both LDO1 and LDO2 to 10 mA

To check the status of the MIC2800 outputs, Power-on Reset Output is available with a pull-up to V_{IN} or to V_{OUT3} . Active low on this output indicates an undervoltage condition on either one of the three regulators.

The board can be powered from 3.6V to 5.5V. This input voltage range is determined by the 3.3V LDO2 that has a dropout voltage of maxim 300 mV overtemperature. If another version of the MIC2800 is placed on the board, the minimum input voltage must comply to $V_{\text{OUTLDO2}} + 300 \text{ mV}$.

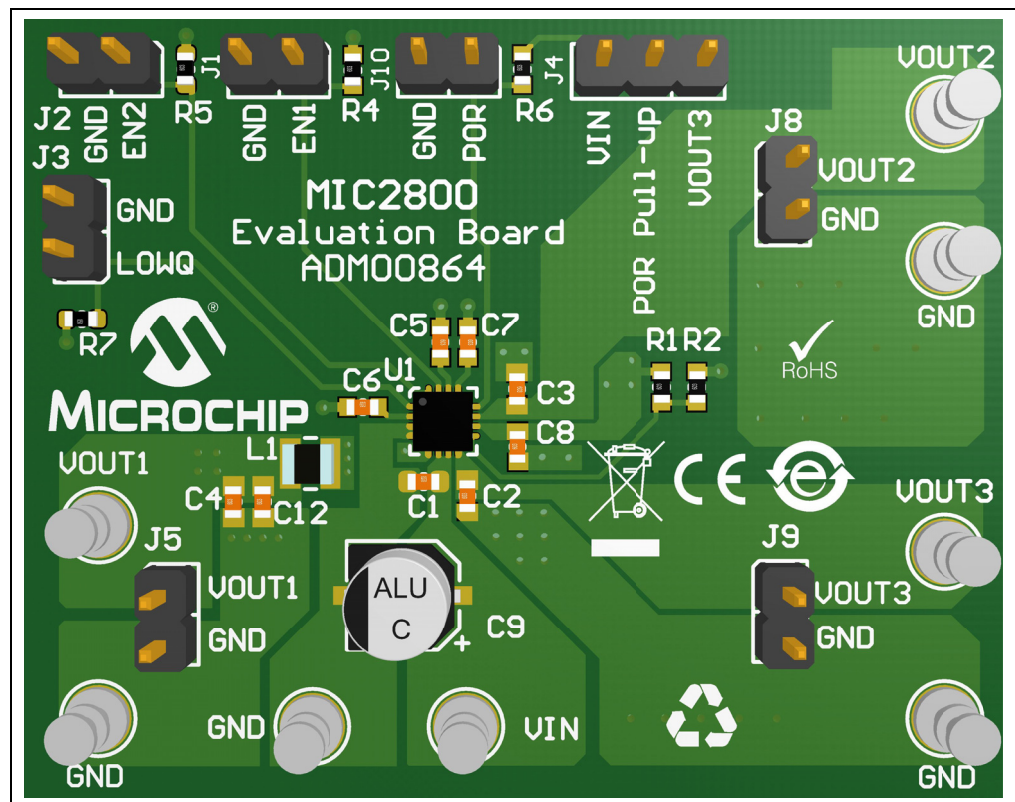

FIGURE 1-2: MIC2800 Evaluation Board – 3D Top View.

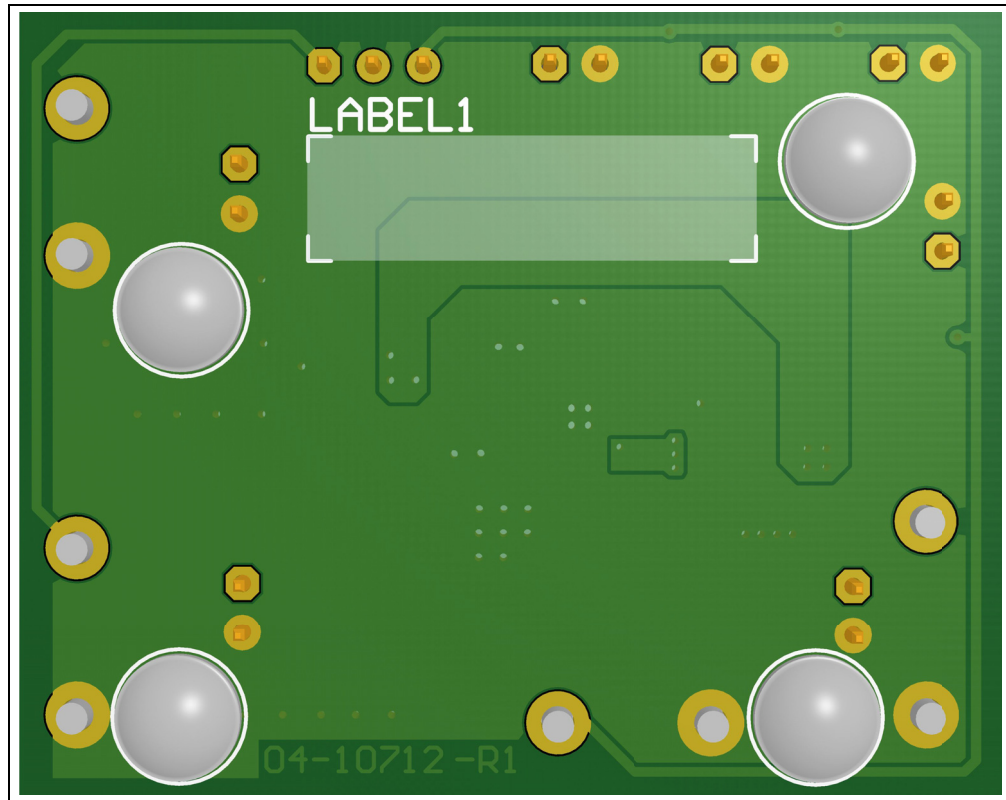

FIGURE 1-3: MIC2800 Evaluation Board – 3D Bottom View.

1.4 MIC2800 EVALUATION BOARD KIT CONTENTS

The MIC2800 Evaluation Board kit includes:

- MIC2800 DC/DC with Dual LDO PMIC Evaluation Board (ADM00864)
- Information Sheet

Chapter 2. Installation and Operation

2.1 INTRODUCTION

The MIC2800 Evaluation Board can be powered from a wide voltage range, from 3.6V to 5.5V, making it compatible with 5V rails and USB power.

2.2 GETTING STARTED

To power up the MIC2800 Evaluation Board, the following steps must be completed:

1. Connect an external supply between V_{IN} and GND terminals. Pay attention to the polarity.
2. With the output of the power supply disabled, set its voltage to the desired input test voltage ($3.6V \leq V_{IN} \leq 5.5V$). An ammeter may be placed between the input supply and the V_{IN} terminals. Be sure to monitor the supply voltage at the V_{IN} terminal, as the ammeter and/or power lead resistance can reduce the voltage supplied to the device.
3. Connect a load between either VOUT1 and GND, VOUT2 and GND, or VOUT3 and GND. The load can be either passive (resistive) or active (electronic load). Some electronic loads can sink the programmed current starting from very low output voltage levels during startup. For a more realistic startup behavior evaluation, a resistive load or constant resistance is recommended. An ammeter may be placed between the load and the output terminals. Ensure the output voltage is monitored at the VOUT1, VOUT2 and VOUT3 terminals. To obtain the best output voltage regulation measurement and low noise, please measure with a ground spring on the output capacitor, corresponding to the desired output.
4. The MIC2800 Enable Pins (EN1, EN2) have pull-up resistors to V_{IN} . By default, the output voltage will be enabled when the input supply of $>2.7V$ is applied. To disable the device, apply a voltage of 0V to the EN1, EN2 terminals (J1 and/or J2).
5. Power-on Reset (POR) test point is provided to monitor the POR function (J10). The power-on reset output will go high after all the output voltages have reached 96% of their nominal voltage and will go low as soon as one of the output voltages go below 91% of its nominal voltage. The POR flag has programmable assertion delay set by the capacitor placed on CSET pin to ground.
6. The inductance associated with long wires between the power supply and the board input may cause voltage spikes at load stepping, start-up into heavy loads or hot wire plug conditions. If the spikes exceed 6V absolute maximum input voltage, the MIC2800 may fail. This behavior is prevented by C9 capacitor (100 μ F Al-Electrolytic capacitor) by absorbing voltage spikes.

MIC2800 Evaluation Board User's Guide

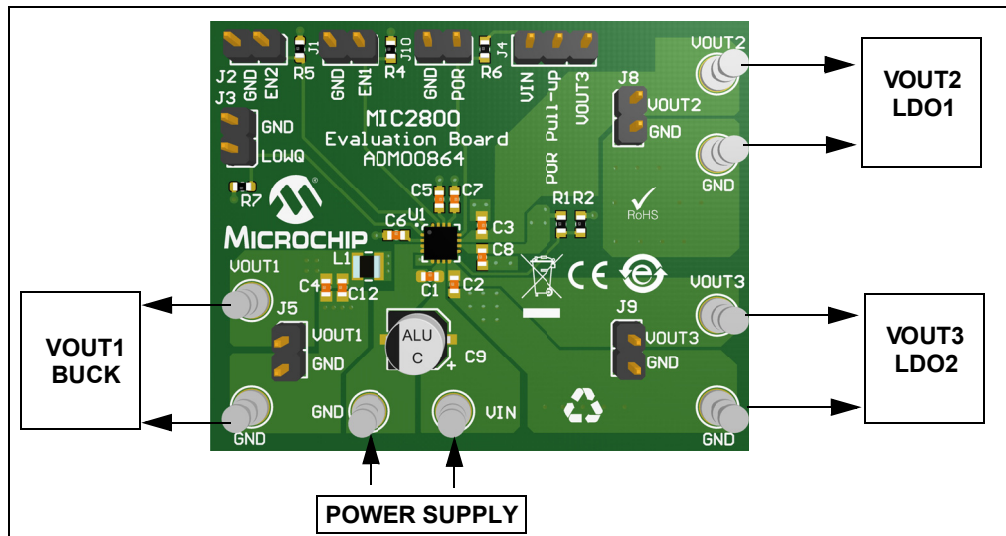

FIGURE 2-1: MIC2800 Evaluation Board – Test Points Description.

2.3 EVALUATION BOARD DESCRIPTION

2.3.1 Power-on Reset Pull-up Resistor

The MIC2800 Evaluation Board offers the possibility of connecting the POR pin to either V_{IN} or VOUT3 (LDO2, 3.3V) by using J4. This provides the flexibility for direct interfacing with 3.3V systems or directly to V_{IN} when the 3.3V rail is disabled.

2.3.2 Power-on Reset Capacitor (C7)

The MIC2800 has a programmable POR delay set by placing a capacitor on the CSET pin. This pin is a current source output that charges a capacitor that sets the delay time for the POR output, from low to high. The current source of 1.25 μA charges a capacitor up from 0V. When the capacitor reaches 1.25V, the output of the POR is allowed to go high. The delay time in microseconds is equal to the CSET capacitor in picofarads (Equation 2-1).

EQUATION 2-1:

$$POR\text{Delay}(\mu\text{s}) = C\text{SET}(\text{pF})$$

2.3.3 LOWQ Mode

MIC2800 is 2 MHz 600 mA DC/DC converter with two integrated 300 mA LDOs. This design combines good overall efficiency with low output noise. However, the DC/DC converter is always switching in PWM mode. To reduce quiescent current in light-load conditions, the MIC2800 features a LOWQ pin. In this mode, the DC/DC converter is disabled and the output voltage is provided by a low noise linear regulator (LDO) capable of supplying 60 mA to the load. In this mode, the other linear regulators (LDO1 and LDO2) will also be internally limited to 10 mA.

2.3.4 Using Fixed and Adjustable Voltage Options

The MIC2800 Evaluation Board is designed for both fixed and adjustable options. Resistors R1 and R2 are used for setting the output voltage of the adjustable option of the DC/DC converter: R1 is the top voltage divider resistor and R2 is the bottom voltage divider resistor. The feedback voltage is 0.8V (nominal) and the output voltage can be adjusted from 1V to 2V. Note that LDO1 is powered from the DC/DC converter's output, so in order for LDO1 to maintain good regulation, the DC/DC output voltage should be minimum $V_{DCDC} - V_{DO}$.

2.3.5 Output Noise and Ripple Measurements

The MIC2800 Evaluation Board is populated with headers used for measuring output noise and ripple on both the DC/DC converter and the LDOs (J5, J8 and J9). Each connector is designed to probe the output signal using the local ground as reference. This is the proper way of measuring low-amplitude ripple signals because it eliminates any noise caused by long oscilloscope ground leads or ground plane noise.

2.3.6 Board Layout Considerations

It is recommended that the connection between the GND pins of the MIC2800 and GND terminals of the input capacitors is kept on the TOP of the PCB and no vias should be placed between them. This will improve transient behavior and decrease noise. It is also recommended that the TOP GND plane should extend under the device for optimal noise performance.

MIC2800 Evaluation Board User's Guide

NOTES:

Appendix A. Schematic and Layouts

A.1 INTRODUCTION

This appendix contains the following schematics and layouts for the MIC2800 Evaluation Board:

- Board – Schematic
- Board – Top Silk
- Board – Top Copper and Silk
- Board – Top Copper
- Board – Bottom Copper
- Board – Bottom Copper and Silk
- Board – Bottom Silk

A.2 BOARD – SCHEMATIC

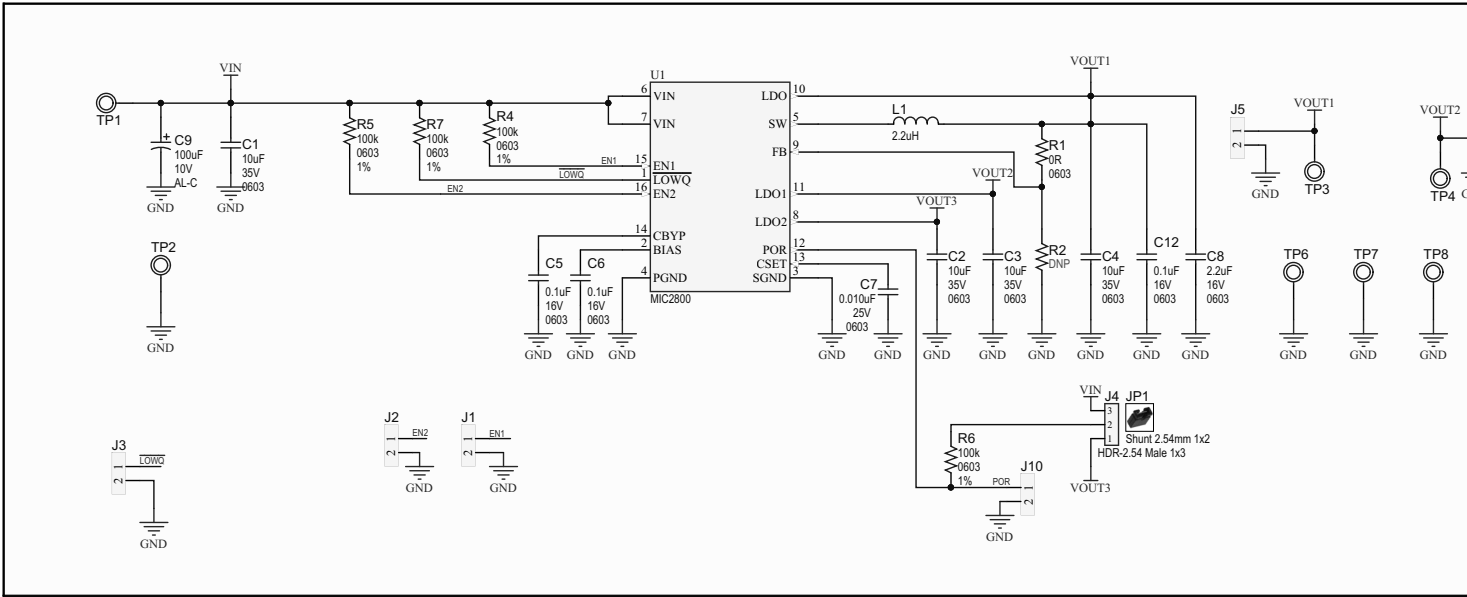

A.3 BOARD – TOP SILK

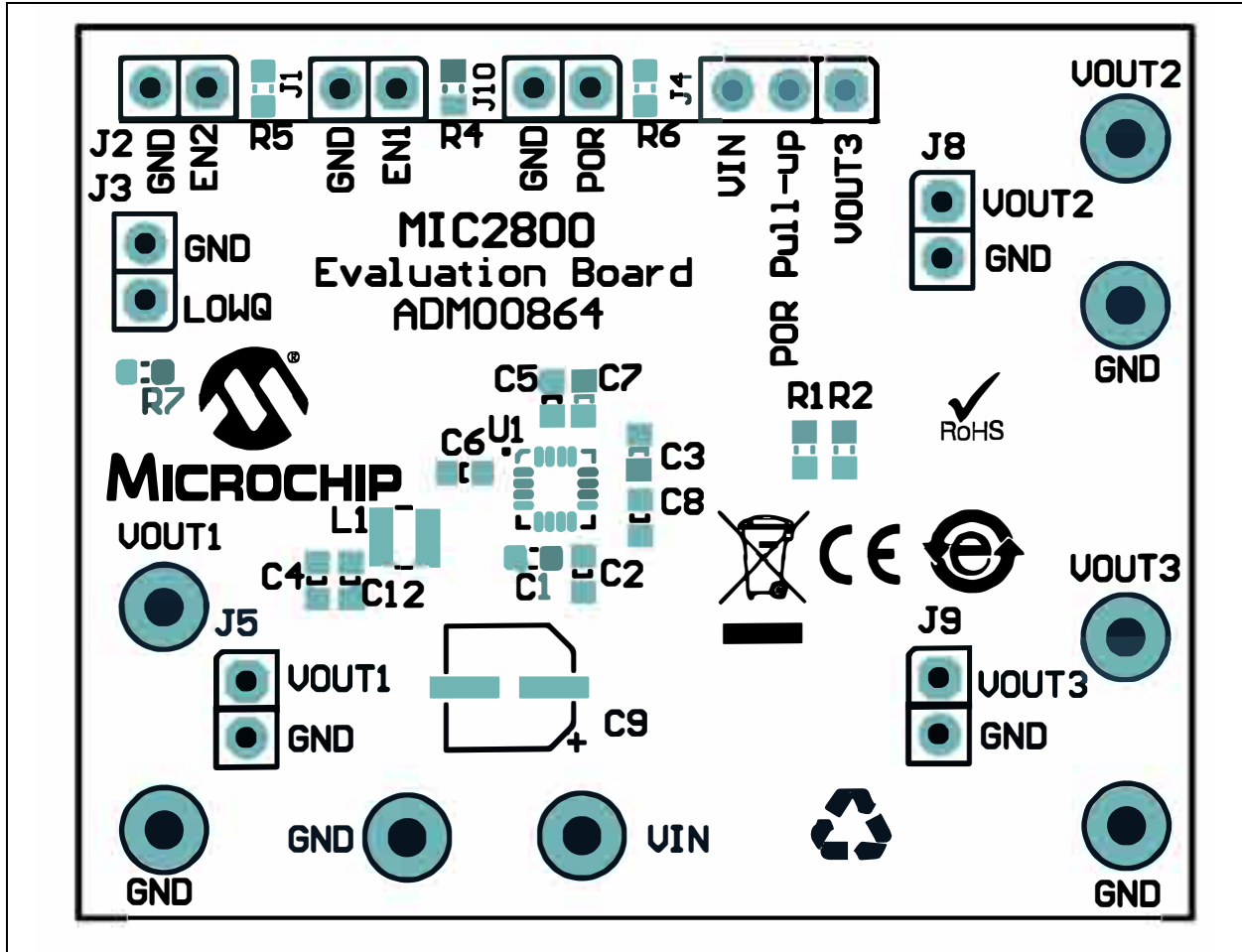

MIC2800 Evaluation Board User's Guide

A.4 BOARD – TOP COPPER AND SILK

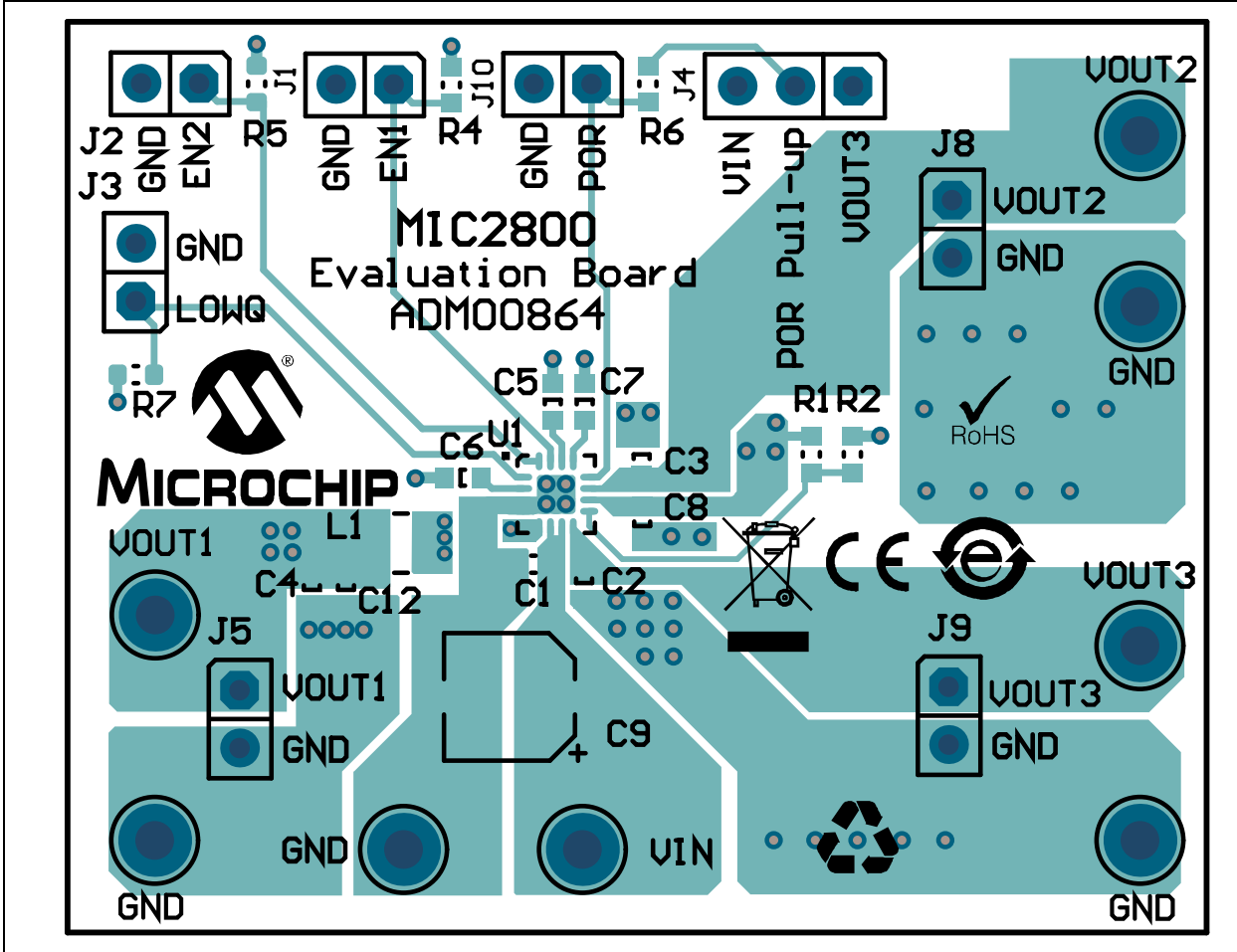

A.5 BOARD – TOP COPPER

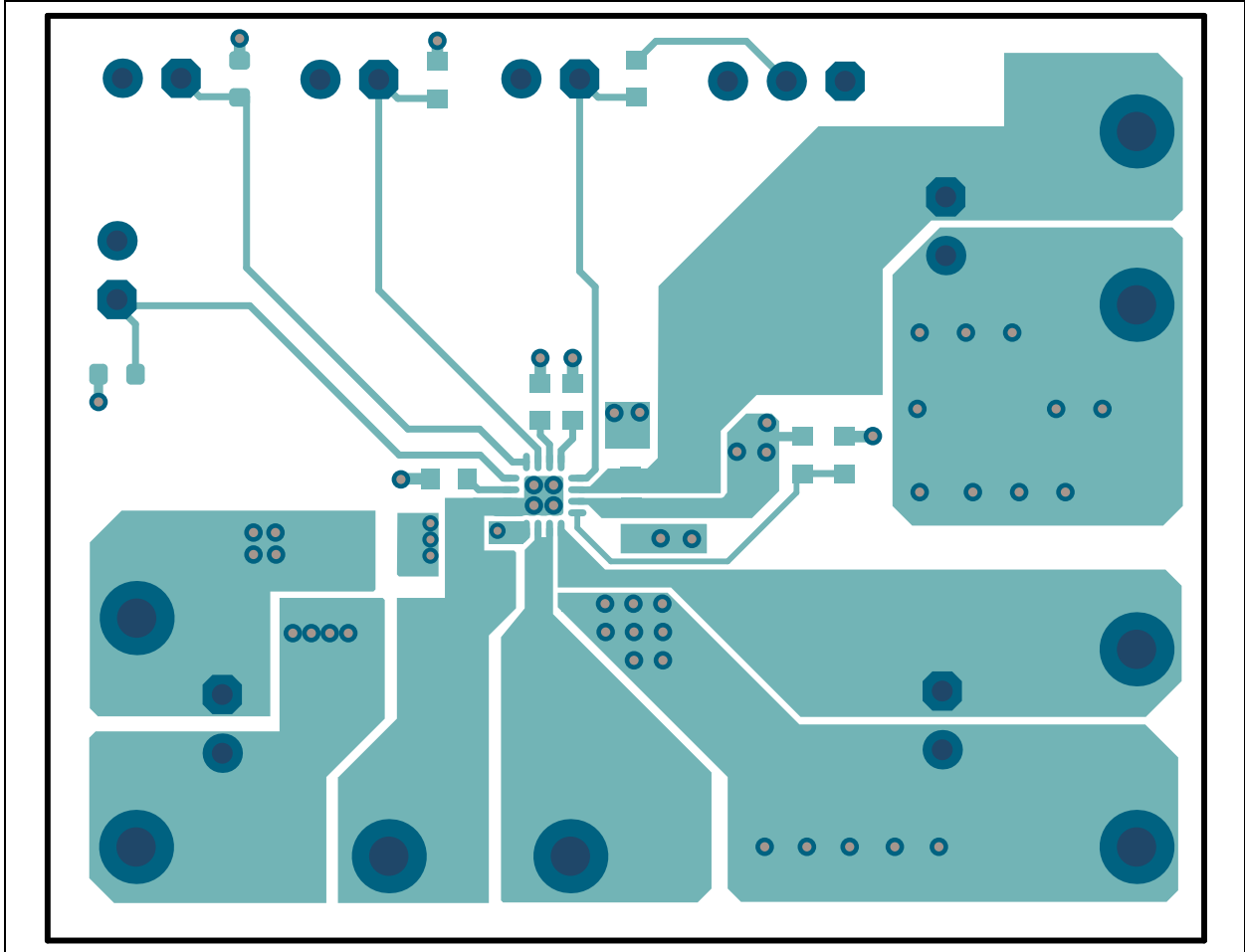

MIC2800 Evaluation Board User's Guide

A.6 BOARD – BOTTOM COPPER

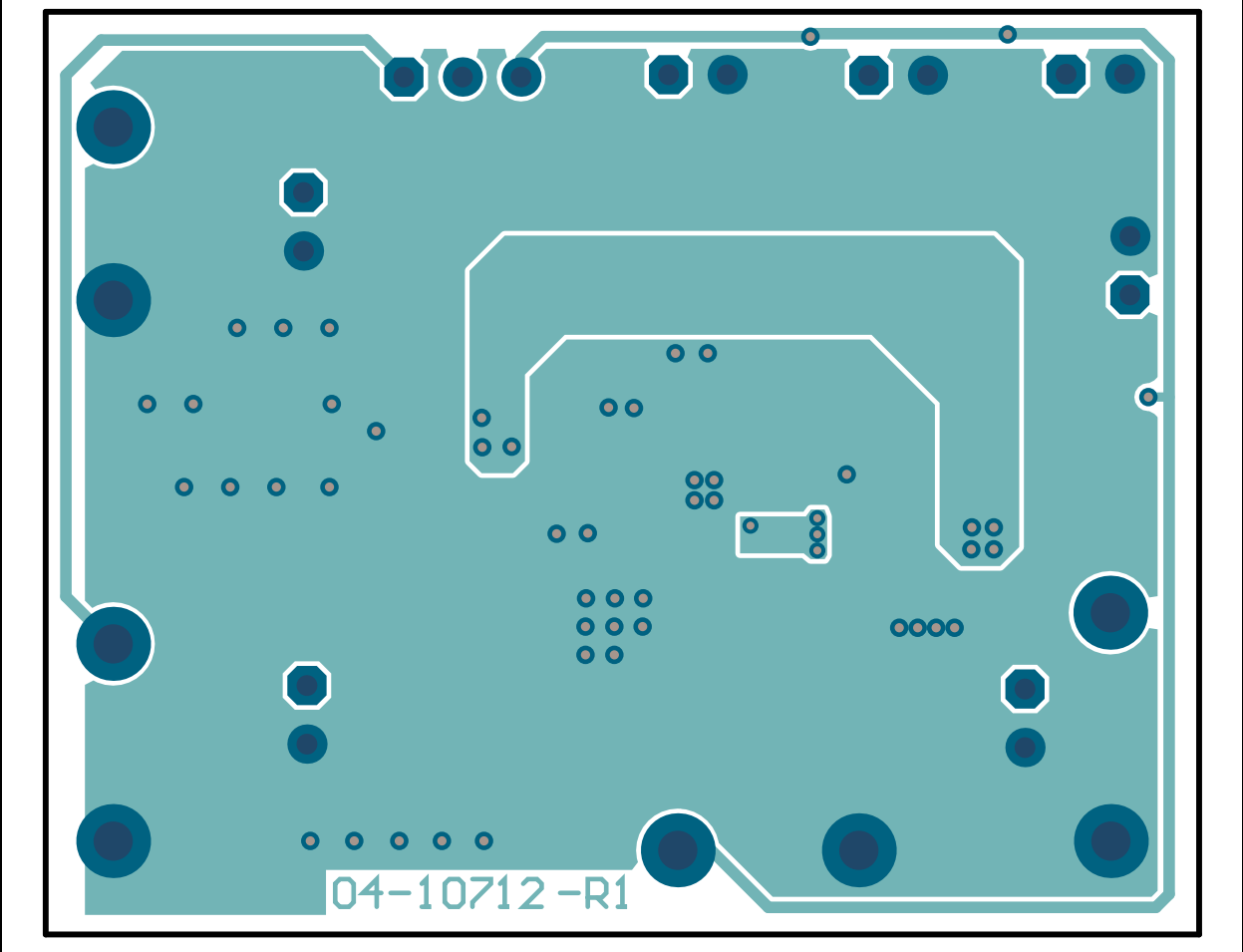

A.7 BOARD – BOTTOM COPPER AND SILK

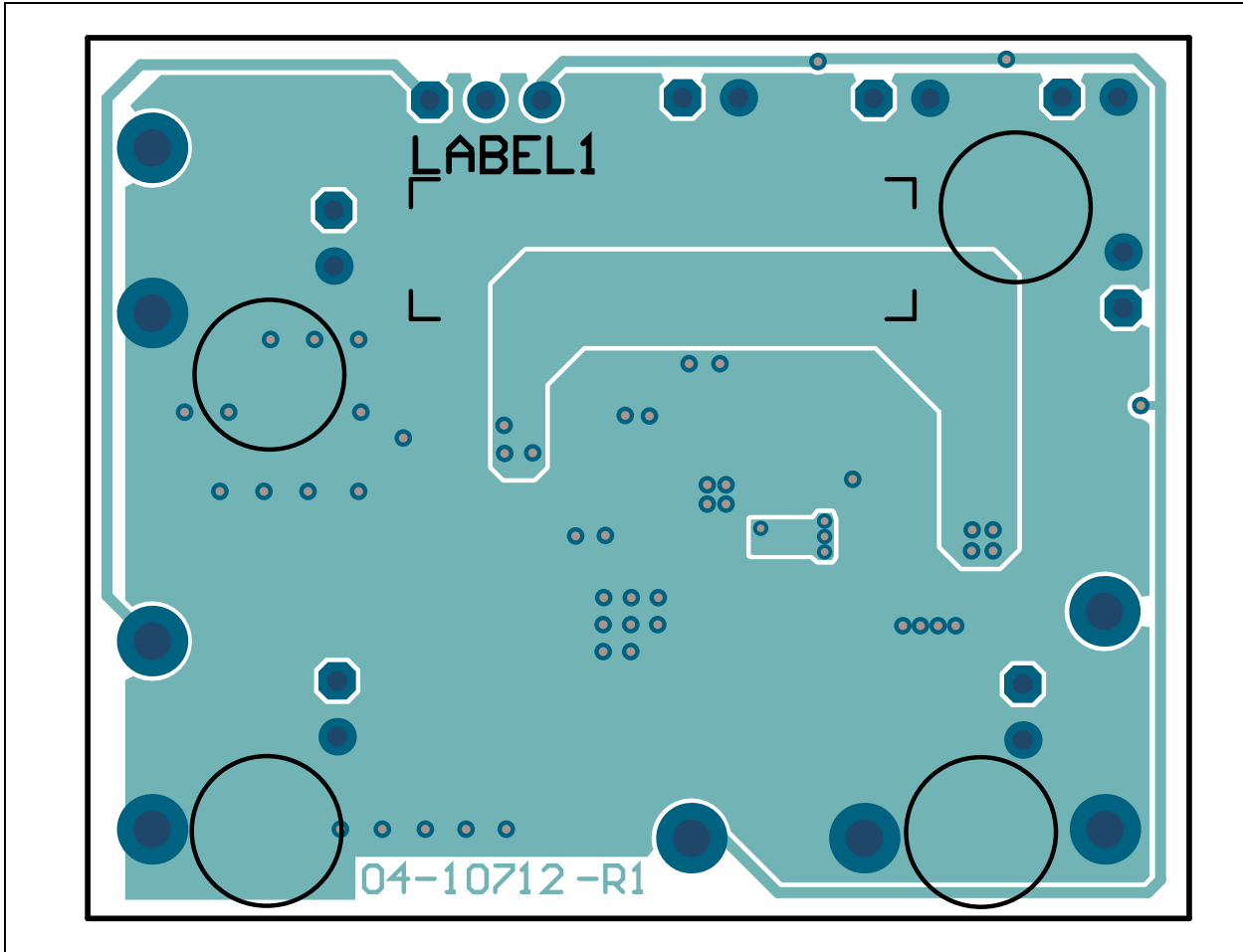

MIC2800 Evaluation Board User's Guide

A.8 BOARD – BOTTOM SILK

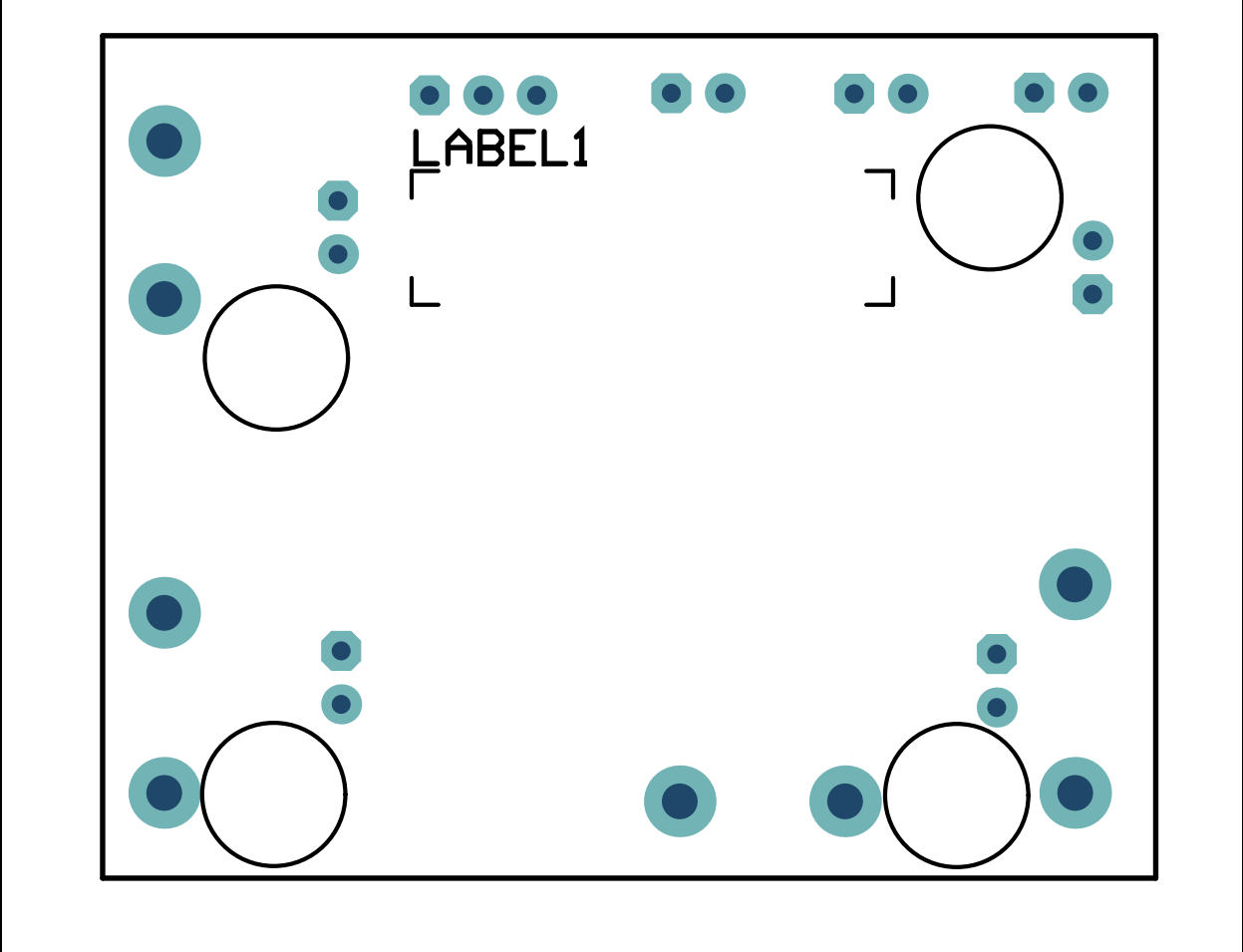

Appendix B. Bill of Materials (BOM)

TABLE B-1: BILL OF MATERIALS (BOM)

Qty.	Reference	Description	Manufacturer	Part Number
4	C1, C2, C3, C4	CAP CER 10 μ F 25V 20% X5R SMD 0603	Murata Electronics®	GRM188R61E106MA73D
3	C5, C6, C12	CAP CER 0.1 μ F 16V 10% X7R SMD 0603	Würth Elektronik	885012206046
1	C7	CAP CER 0.010 μ F 25V 10% X7R SMD 0603	Yageo Corporation	CC0603KRX7R8BB103
1	C8	CAP CER 2.2 μ F 10V 10% X7R SMD 0603	Murata Electronics®	GRM188R71A225KE15D
7	J1, J2, J3, J5, J8, J9, J10	CON HDR-2.54 Male 1x2 Gold 5.84MH TH VERT	FCI	77311-118-02LF
1	J4	CON HDR-2.54 Male 1x3 Gold 5.84MH TH VERT	FCI	68000-103HLF
	JP1	MECH HW JUMPER 2.54mm 1x2 GOLD	Würth Elektronik	60900213421
1	L1	INDUCTOR 2.2 μ H 1.3A 20% SMD 1008	TDK Corporation	MLP2520H2R2MT0S1
1	PCB	MIC2800 Evaluation Board – Printed Circuit Board	Microchip Technology Inc.	04-10712-R1
1	R1	RES TKF 0R 1/10W SMD 0603	Panasonic® - ECG	ERJ-3GSY0R00V
4	R4, R5, R6, R7	RES TF 100 k Ω 1% 1/8W SMD 0603	Vishay Intertechnology, Inc.	MCT06030C1003FP500
8	TP1, TP2, TP3, TP4, TP5, TP6, TP7, TP8	CON TP PIN Tin TH	Harwin Plc.	H2121-01
1	C9	CAP ALU 100 μ F 10V 20% SMD C	Panasonic® - ECG	EEE-1AA101WR
1	U1	MCHP ANALOG SWITCHER Buck 1.8V to 3.3V MIC2800-G1JSYML-TR VQFN-16	Microchip Technology Inc.	MIC2800-G1JSYML-TR

Note 1: The components listed in this Bill of Materials are representative of the PCB assembly. The released BOM used in manufacturing uses all RoHS-compliant components

MIC2800 Evaluation Board User's Guide

NOTES:



MICROCHIP

Worldwide Sales and Service

AMERICAS

Corporate Office
2355 West Chandler Blvd.
Chandler, AZ 85224-6199
Tel: 480-792-7200
Fax: 480-792-7277
Technical Support:
<http://www.microchip.com/support>
Web Address:
www.microchip.com

Atlanta

Duluth, GA
Tel: 678-957-9614
Fax: 678-957-1455

Austin, TX

Tel: 512-257-3370

Boston

Westborough, MA
Tel: 774-760-0087
Fax: 774-760-0088

Chicago

Itasca, IL
Tel: 630-285-0071
Fax: 630-285-0075

Dallas

Addison, TX
Tel: 972-818-7423
Fax: 972-818-2924

Detroit

Novi, MI
Tel: 248-848-4000

Houston, TX

Tel: 281-894-5983

Indianapolis

Noblesville, IN
Tel: 317-773-8323
Fax: 317-773-5453
Tel: 317-536-2380

Los Angeles

Mission Viejo, CA
Tel: 949-462-9523
Fax: 949-462-9608
Tel: 951-273-7800

Raleigh, NC

Tel: 919-844-7510

New York, NY

Tel: 631-435-6000

San Jose, CA

Tel: 408-735-9110
Tel: 408-436-4270

Canada - Toronto

Tel: 905-695-1980
Fax: 905-695-2078

ASIA/PACIFIC

Australia - Sydney
Tel: 61-2-9868-6733

China - Beijing
Tel: 86-10-8569-7000

China - Chengdu
Tel: 86-28-8665-5511

China - Chongqing
Tel: 86-23-8980-9588

China - Dongguan
Tel: 86-769-8702-9880

China - Guangzhou
Tel: 86-20-8755-8029

China - Hangzhou
Tel: 86-571-8792-8115

China - Hong Kong SAR
Tel: 852-2943-5100

China - Nanjing
Tel: 86-25-8473-2460

China - Qingdao
Tel: 86-532-8502-7355

China - Shanghai
Tel: 86-21-3326-8000

China - Shenyang
Tel: 86-24-2334-2829

China - Shenzhen
Tel: 86-755-8864-2200

China - Suzhou
Tel: 86-186-6233-1526

China - Wuhan
Tel: 86-27-5980-5300

China - Xian
Tel: 86-29-8833-7252

China - Xiamen
Tel: 86-592-2388138

China - Zhuhai
Tel: 86-756-3210040

ASIA/PACIFIC

India - Bangalore
Tel: 91-80-3090-4444

India - New Delhi
Tel: 91-11-4160-8631

India - Pune
Tel: 91-20-4121-0141

Japan - Osaka
Tel: 81-6-6152-7160

Japan - Tokyo
Tel: 81-3-6880-3770

Korea - Daegu
Tel: 82-53-744-4301

Korea - Seoul
Tel: 82-2-554-7200

Malaysia - Kuala Lumpur
Tel: 60-3-7651-7906

Malaysia - Penang
Tel: 60-4-227-8870

Philippines - Manila
Tel: 63-2-634-9065

Singapore
Tel: 65-6334-8870

Taiwan - Hsin Chu
Tel: 886-3-577-8366

Taiwan - Kaohsiung
Tel: 886-7-213-7830

Taiwan - Taipei
Tel: 886-2-2508-8600

Thailand - Bangkok
Tel: 66-2-694-1351

Vietnam - Ho Chi Minh
Tel: 84-28-5448-2100

EUROPE

Austria - Wels
Tel: 43-7242-2244-39
Fax: 43-7242-2244-393

Denmark - Copenhagen
Tel: 45-4450-2828
Fax: 45-4485-2829

Finland - Espoo
Tel: 358-9-4520-820

France - Paris
Tel: 33-1-69-53-63-20
Fax: 33-1-69-30-90-79

Germany - Garching
Tel: 49-8931-9700

Germany - Haan
Tel: 49-2129-3766400

Germany - Heilbronn
Tel: 49-7131-67-3636

Germany - Karlsruhe
Tel: 49-721-625370

Germany - Munich
Tel: 49-89-627-144-0
Fax: 49-89-627-144-44

Germany - Rosenheim
Tel: 49-8031-354-560

Israel - Ra'anana
Tel: 972-9-744-7705

Italy - Milan
Tel: 39-0331-742611
Fax: 39-0331-466781

Italy - Padova
Tel: 39-049-7625286

Netherlands - Drunen
Tel: 31-416-690399
Fax: 31-416-690340

Norway - Trondheim
Tel: 47-7289-7561

Poland - Warsaw
Tel: 48-22-3325737

Romania - Bucharest
Tel: 40-21-407-87-50

Spain - Madrid
Tel: 34-91-708-08-90
Fax: 34-91-708-08-91

Sweden - Gothenberg
Tel: 46-31-704-60-40

Sweden - Stockholm
Tel: 46-8-5090-4654

UK - Wokingham
Tel: 44-118-921-5800
Fax: 44-118-921-5820

X-ON Electronics

Largest Supplier of Electrical and Electronic Components

Click to view similar products for [Power Management IC Development Tools](#) category:

Click to view products by [Microchip](#) manufacturer:

Other Similar products are found below :

[EVB-EP5348UI](#) [MIC23451-AAAYFL EV](#) [MIC5281YMME EV](#) [124352-HMC860LP3E](#) [DA9063-EVAL](#) [ADP122-3.3-EVALZ](#) [ADP130-0.8-EVALZ](#) [ADP130-1.8-EVALZ](#) [ADP1740-1.5-EVALZ](#) [ADP1870-0.3-EVALZ](#) [ADP1874-0.3-EVALZ](#) [ADP199CB-EVALZ](#) [ADP2102-1.25-EVALZ](#) [ADP2102-1.875EVALZ](#) [ADP2102-1.8-EVALZ](#) [ADP2102-2-EVALZ](#) [ADP2102-3-EVALZ](#) [ADP2102-4-EVALZ](#) [AS3606-DB](#) [BQ25010EVM](#) [BQ3055EVM](#) [ISLUSBI2CKIT1Z](#) [LP38512TS-1.8EV](#) [EVAL-ADM1186-1MBZ](#) [EVAL-ADM1186-2MBZ](#) [ADP122UJZ-REDYKIT](#) [ADP166Z-REDYKIT](#) [ADP170-1.8-EVALZ](#) [ADP171-EVALZ](#) [ADP1853-EVALZ](#) [ADP1873-0.3-EVALZ](#) [ADP198CP-EVALZ](#) [ADP2102-1.0-EVALZ](#) [ADP2102-1-EVALZ](#) [ADP2107-1.8-EVALZ](#) [ADP5020CP-EVALZ](#) [CC-ACC-DBMX-51](#) [ATPL230A-EK](#) [MIC23250-S4YMT EV](#) [MIC26603YJL EV](#) [MIC33050-SYHL EV](#) [TPS60100EVM-131](#) [TPS65010EVM-230](#) [TPS71933-28EVM-213](#) [TPS72728YFFEVM-407](#) [TPS79318YEQEVM](#) [UCC28810EVM-002](#) [XILINXPWR-083](#) [LMR22007YMINI-EVM](#) [LP38501ATJ-EV](#)