



MICROCHIP

MCP1663
USB Programmable
Power Supply Reference Design
User's Guide

Note the following details of the code protection feature on Microchip devices:

- Microchip products meet the specification contained in their particular Microchip Data Sheet.
- Microchip believes that its family of products is one of the most secure families of its kind on the market today, when used in the intended manner and under normal conditions.
- There are dishonest and possibly illegal methods used to breach the code protection feature. All of these methods, to our knowledge, require using the Microchip products in a manner outside the operating specifications contained in Microchip's Data Sheets. Most likely, the person doing so is engaged in theft of intellectual property.
- Microchip is willing to work with the customer who is concerned about the integrity of their code.
- Neither Microchip nor any other semiconductor manufacturer can guarantee the security of their code. Code protection does not mean that we are guaranteeing the product as "unbreakable."

Code protection is constantly evolving. We at Microchip are committed to continuously improving the code protection features of our products. Attempts to break Microchip's code protection feature may be a violation of the Digital Millennium Copyright Act. If such acts allow unauthorized access to your software or other copyrighted work, you may have a right to sue for relief under that Act.

Information contained in this publication regarding device applications and the like is provided only for your convenience and may be superseded by updates. It is your responsibility to ensure that your application meets with your specifications. MICROCHIP MAKES NO REPRESENTATIONS OR WARRANTIES OF ANY KIND WHETHER EXPRESS OR IMPLIED, WRITTEN OR ORAL, STATUTORY OR OTHERWISE, RELATED TO THE INFORMATION, INCLUDING BUT NOT LIMITED TO ITS CONDITION, QUALITY, PERFORMANCE, MERCHANTABILITY OR FITNESS FOR PURPOSE. Microchip disclaims all liability arising from this information and its use. Use of Microchip devices in life support and/or safety applications is entirely at the buyer's risk, and the buyer agrees to defend, indemnify and hold harmless Microchip from any and all damages, claims, suits, or expenses resulting from such use. No licenses are conveyed, implicitly or otherwise, under any Microchip intellectual property rights unless otherwise stated.

Microchip received ISO/TS-16949:2009 certification for its worldwide headquarters, design and wafer fabrication facilities in Chandler and Tempe, Arizona; Gresham, Oregon and design centers in California and India. The Company's quality system processes and procedures are for its PIC® MCUs and dsPIC® DSCs, KEELOQ® code hopping devices, Serial EEPROMs, microperipherals, nonvolatile memory and analog products. In addition, Microchip's quality system for the design and manufacture of development systems is ISO 9001:2000 certified.

**QUALITY MANAGEMENT SYSTEM
CERTIFIED BY DNV
= ISO/TS 16949 =**

Trademarks

The Microchip name and logo, the Microchip logo, AnyRate, AVR, AVR logo, AVR Freaks, BeaconThings, BitCloud, CryptoMemory, CryptoRF, dsPIC, FlashFlex, flexPWR, Helder, JukeBlox, KEELOQ, KEELOQ logo, Klear, LANCheck, LINK MD, maXStylus, maXTouch, MediaLB, megaAVR, MOST, MOST logo, MPLAB, OptoLyzer, PIC, picoPower, PICSTART, PIC32 logo, Prochip Designer, QTouch, RightTouch, SAM-BA, SpyNIC, SST, SST Logo, SuperFlash, tinyAVR, UNI/O, and XMEGA are registered trademarks of Microchip Technology Incorporated in the U.S.A. and other countries.

ClockWorks, The Embedded Control Solutions Company, EtherSynch, Hyper Speed Control, HyperLight Load, IntellIMOS, mTouch, Precision Edge, and Quiet-Wire are registered trademarks of Microchip Technology Incorporated in the U.S.A.

Adjacent Key Suppression, AKS, Analog-for-the-Digital Age, Any Capacitor, AnyIn, AnyOut, BodyCom, chipKIT, chipKIT logo, CodeGuard, CryptoAuthentication, CryptoCompanion, CryptoController, dsPICDEM, dsPICDEM.net, Dynamic Average Matching, DAM, ECAN, EtherGREEN, In-Circuit Serial Programming, ICSP, Inter-Chip Connectivity, JitterBlocker, KlearNet, KlearNet logo, Mindi, MiWi, motorBench, MPASM, MPF, MPLAB Certified logo, MPLIB, MPLINK, MultiTRAK, NetDetach, Omniscient Code Generation, PICDEM, PICDEM.net, PICkit, PICtail, PureSilicon, QMatrix, RightTouch logo, REAL ICE, Ripple Blocker, SAM-ICE, Serial Quad I/O, SMART-I.S., SQI, SuperSwitcher, SuperSwitcher II, Total Endurance, TSHARC, USBCheck, VariSense, ViewSpan, WiperLock, Wireless DNA, and ZENA are trademarks of Microchip Technology Incorporated in the U.S.A. and other countries.

SQTP is a service mark of Microchip Technology Incorporated in the U.S.A.

Silicon Storage Technology is a registered trademark of Microchip Technology Inc. in other countries.

GestIC is a registered trademark of Microchip Technology Germany II GmbH & Co. KG, a subsidiary of Microchip Technology Inc., in other countries.

All other trademarks mentioned herein are property of their respective companies.

© 2018, Microchip Technology Incorporated, All Rights Reserved.
ISBN: 978-1-5224-2795-7



MCP1663 USB PROGRAMMABLE POWER SUPPLY REFERENCE DESIGN USER'S GUIDE

Table of Contents

Preface	3
Introduction.....	3
Document Layout	3
Conventions Used in this Guide	4
Recommended Reading.....	5
The Microchip Web Site	5
Customer Support	5
Document Revision History	5
Chapter 1. Product Overview	
1.1 Introduction	7
1.2 Core Components Short Overview	7
1.2.1 MCP1663 Device Overview	7
1.2.2 MCP2221 Device Overview	8
1.2.3 USB3751 Device Overview	8
1.2.4 MCP4562 Device Overview	10
1.2.5 PAC1710 Device Overview	11
1.3 The MCP1663 USB Programmable Power Supply	12
1.4 What the MCP1663 USB Programmable Power Supply Kit Contains	12
Chapter 2. Installation and Operation	
2.1 Introduction	13
2.2 MCP1663 USB Programmable Power Supply Features	13
2.2.1 Board Features	13
2.2.2 Application Features	13
2.3 Getting Started	14
2.4 Operation	14
Chapter 3. GUI Installation and Operation	
3.1 Getting Started	15
3.1.1 Required Software	15
3.1.2 Required Hardware	15
3.2 Graphical User Interface Installation	15
3.3 MCP1663 USB Programmable Power Supply GUI Uninstall	18
Chapter 4. GUI Description	
4.1 Introduction	21
4.2 The Graphical User Interface	21

Appendix A. Schematics and Layouts

A.1 Introduction	23
A.2 Board – Schematic	24
A.3 Board – Top Silk	25
A.4 Board – Top Copper and Silk	25
A.5 Board – Top Copper	26
A.6 Board – Bottom Copper	26
A.7 Board – Bottom Copper and Silk	27
A.8 Board – Bottom Silk	27

Appendix B. Bill of Materials (BOM)29

Worldwide Sales and Service31



MCP1663 USB PROGRAMMABLE POWER SUPPLY REFERENCE DESIGN USER'S GUIDE

Preface

NOTICE TO CUSTOMERS

All documentation becomes dated, and this manual is no exception. Microchip tools and documentation are constantly evolving to meet customer needs, so some actual dialogs and/or tool descriptions may differ from those in this document. Please refer to our website (www.microchip.com) to obtain the latest documentation available.

Documents are identified with a “DS” number. This number is located on the bottom of each page, in front of the page number. The numbering convention for the DS number is “DSXXXXXXXXA”, where “XXXXXXXX” is the document number and “A” is the revision level of the document.

For the most up-to-date information on development tools, see the MPLAB® IDE online help. Select the Help menu, and then Topics to open a list of available online help files.

INTRODUCTION

This chapter contains general information that will be useful to know before using the MCP1663 USB Programmable Power Supply. Items discussed in this chapter include:

- [Document Layout](#)
- [Conventions Used in this Guide](#)
- [Recommended Reading](#)
- [The Microchip Web Site](#)
- [Customer Support](#)
- [Document Revision History](#)

DOCUMENT LAYOUT

This document describes how to use the MCP1663 USB Programmable Power Supply Reference Design as a development tool. The manual layout is as follows:

- **Chapter 1. “Product Overview”** – Important information about the MCP1663 USB Programmable Power Supply.
- **Chapter 2. “Installation and Operation”** – Includes description and instructions on how to use the MCP1663 USB Programmable Power Supply.
- **Chapter 3. “GUI Installation and Operation”** – Includes instructions on how to install the Graphical User Interface (GUI).
- **Chapter 4. “GUI Description”** – Includes the description for the GUI.
- **Appendix A. “Schematics and Layouts”** – Shows the schematic and layout diagrams for the MCP1663 USB Programmable Power Supply.
- **Appendix B. “Bill of Materials (BOM)”** – Lists the parts used to build the MCP1663 USB Programmable Power Supply.

CONVENTIONS USED IN THIS GUIDE

This manual uses the following documentation conventions:

DOCUMENTATION CONVENTIONS

Description	Represents	Examples
Arial font:		
Italic characters	Referenced books	<i>MPLAB® IDE User's Guide</i>
	Emphasized text	...is the <i>only</i> compiler...
Initial caps	A window	the Output window
	A dialog	the Settings dialog
	A menu selection	select Enable Programmer
Quotes	A field name in a window or dialog	"Save project before build"
Underlined, italic text with right angle bracket	A menu path	<u><i>File>Save</i></u>
Bold characters	A dialog button	Click OK
	A tab	Click the Power tab
N'Rnnnn	A number in verilog format, where N is the total number of digits, R is the radix and n is a digit.	4'b0010, 2'hF1
Text in angle brackets < >	A key on the keyboard	Press <Enter>, <F1>
Courier New font:		
Plain Courier New	Sample source code	#define START
	Filenames	autoexec.bat
	File paths	c:\mcc18\h
	Keywords	_asm, _endasm, static
	Command-line options	-Opa+, -Opa-
	Bit values	0, 1
	Constants	0xFF, 'A'
Italic Courier New	A variable argument	<i>file.o</i> , where <i>file</i> can be any valid filename
Square brackets []	Optional arguments	mcc18 [options] <i>file</i> [options]
Curly brackets and pipe character: { }	Choice of mutually exclusive arguments; an OR selection	errorlevel {0 1}
Ellipses...	Replaces repeated text	var_name [, var_name...]
	Represents code supplied by user	void main (void) { ... }

RECOMMENDED READING

This user's guide describes how to use the MCP1663 USB Programmable Power Supply Reference Design. Other useful documents are listed below. The following Microchip documents are available and recommended as supplemental reference resources:

- **MIC1663 Data Sheet – “High Voltage Integrated Switch PWM Boost Regulator with UVLO” (DS20005406).**
- **MCP2221 Data Sheet – “USB 2.0 to I²C/UART Protocol Converter with GPIO” (DS20005292).**
- **USB375x Data Sheet – “USB 2.0 Protection IC with Battery Charger Detection” (DS0001824).**
- **MCP454X/456X/464X/466X Data Sheet – “7/8-Bit Single/Dual I2C Digital POT with Nonvolatile Memory” (DS22107).**
- **PAC1710/20 Data Sheet – “Single and Dual High-Side Current-Sense Monitor with Power Calculation” (DS20005386).**

THE MICROCHIP WEB SITE

Microchip provides online support via our web site at www.microchip.com. This web site is used as a means to make files and information easily available to customers. Accessible by using your favorite Internet browser, the website contains the following information:

- **Product Support** – Data sheets and errata, application notes and sample programs, design resources, user's guides and hardware support documents, latest software releases and archived software
- **General Technical Support** – Frequently Asked Questions (FAQs), technical support requests, online discussion groups, Microchip consultant program member listing
- **Business of Microchip** – Product selector and ordering guides, latest Microchip press releases, listing of seminars and events, listings of Microchip sales offices, distributors and factory representatives

CUSTOMER SUPPORT

Users of Microchip products can receive assistance through several channels:

- Distributor or Representative
- Local Sales Office
- Field Application Engineer (FAE)
- Technical Support

Customers should contact their distributor, representative or field application engineer (FAE) for support. Local sales offices are also available to help customers. A listing of sales offices and locations is included in the back of this document.

Technical support is available through the web site at:
<http://www.microchip.com/support>

DOCUMENT REVISION HISTORY

Revision A (March 2018)

- Initial Release of this Document.

NOTES:

Chapter 1. Product Overview

1.1 INTRODUCTION

This chapter provides an overview of the MCP1663 USB Programmable Power Supply and covers the following topics:

- Core Components Short Overview
- The MCP1663 USB Programmable Power Supply
- What the MCP1663 USB Programmable Power Supply Kit Contains

1.2 CORE COMPONENTS SHORT OVERVIEW

1.2.1 MCP1663 Device Overview

The MCP1663 is a compact, high-efficiency, fixed-frequency, nonsynchronous step-up DC/DC converter that integrates a 36V, 400 mΩ switch. This easy-to-use product provides a space-efficient high-voltage step-up, power supply solution. The MCP1663 was developed for applications powered by two-cell or three-cell alkaline, Energizer® Ultimate Lithium, Ni-Cd, Ni-MH batteries, or Li-Ion or Li-Polymer batteries. The MCP1663 operates in Pulse-Width Modulation (PWM), at a fixed 500 kHz switching frequency. The device features an undervoltage lockout (UVLO) that prevents fault operation below 1.85V (UVLO_{STOP}), corresponding to the value of two discharged batteries. The MCP1663 starts its normal operation at 2.3V input voltage (UVLO_{START}) and the operating input voltage ranges from 2.4V to 5.5V.

For standby applications, MCP1663 can be put in Shutdown by pulling the EN pin to GND. The device will stop switching and will consume a few μA of input current, including feedback divider current (250 nA typical). MCP1663 also provides overvoltage protection (OVP) in the event of the following conditions:

- A short-circuit of the feedback pin to GND
- A disconnected feedback divider

In these conditions, the OVP function will stop the internal driver and prevent damage to the device. This feature is disabled during the start-up sequence and Thermal Shutdown state.

1.2.1.1 DEVICE FEATURES:

- 36V, 400 mΩ Integrated Switch
- Up to 92% Efficiency
- Output Voltage Range: up to 32V
- 1.8A Peak Input Current Limit:
 - I_{OUT} > 375 mA @ 5.0V V_{IN}, 12V V_{OUT}
 - I_{OUT} > 200 mA @ 3.3V V_{IN}, 12V V_{OUT}
 - I_{OUT} > 150 mA @ 4.2V V_{IN}, 24V V_{OUT}
- Input Voltage Range: 2.4V to 5.5V

- Undervoltage Lockout (UVLO):
 - UVLO at V_{IN} Rising: 2.3V, typical
 - UVLO at V_{IN} Falling: 1.85V, typical
- No Load Input Current: 250 μ A, typical
- Sleep mode with 0.3 μ A Typical Shutdown Quiescent Current
- PWM Operation with Skip Mode: 500 kHz
- Feedback Voltage Reference: $V_{FB} = 1.227V$
- Cycle-by-Cycle Current Limiting
- Internal Compensation
- Inrush Current Limiting and Internal Soft Start
- Output Overvoltage Protection (OVP) in the event of:
 - Feedback pin shorted to GND
 - Disconnected feedback divider
- Overtemperature Protection
- Easily Configurable for SEPIC, Cuk or Flyback Topologies

1.2.2 MCP2221 Device Overview

The MCP2221 is a USB-to-UART/I²C serial converter that enables USB connectivity between applications that have a UART and I²C interfaces. The device reduces external components by integrating the USB termination resistors and the oscillator needed for USB operation. The MCP2221 also has four GP pins providing miscellaneous functions (GPIO, USBCFG, SSPND, Clock Output, ADC, DAC, interrupt detector).

1.2.2.1 DEVICE FEATURES:

- Supports full-speed USB (12 Mb/s)
- Implements USB protocol composite device
- 128-byte Buffer to handle data throughput at any UART baud rate
- Human Interface Device (HID) for both I²C communication and control
- 64 byte buffer to handle data throughput at any I²C baud rate
- Fully configurable VID and PID assignments, and string descriptors
- Bus-powered or self-powered
- USB 2.0 Compliant
- USB Driver and Software Support
- CDC and Universal Asynchronous Receiver/Transmitter (UART) Options
- I²C/SMBus
- SMBus Master

1.2.3 USB3751 Device Overview

The USB375x integrates many features that have historically been discrete devices in a mobile product. This device provides significant VBUS protection for the entire system, robust USB interface ESD protection, a USB 2.0 compliant High-Speed switch, and USB-IF Battery Charger detection (revision 1.1) capabilities that are essential to the latest mobile products. Several advanced features allow the USB375x to be optimized for portable applications and to reduce both the BOM part count and PCB area. ESD robustness eliminates the need for external ESD protection devices. In addition to the integrated ESD protection on the USB interface, the USB375x provides VBUS Overvoltage Protection (OVP). The USB375x integrated battery charger detection circuitry supports USB-IF Battery Charger Detection.

Battery charger detection will begin automatically whenever VBUS rises above the UVLO threshold, and can also be completed manually through the I²C interface. The USB375x can detect a range of USB battery chargers including a Standard Downstream Port (SDP), a Charging Downstream Port (CDP) and a Dedicated Charging Port (DCP). For more information on USB battery charger detection, please see the USB Battery Charging Specification, Revision 1.1.

The I²C interface gives processor control over the USB Switch, charger detection, OVLO settings, and status of the USB375x. In addition, custom charger detection can be implemented through the I²C interface.

The USB375x family is enabled with SMSC's RapidCharge Anywhere™, which supports USB-IF Battery Charging 1.1 for any portable device. RapidCharge Anywhere™ provides three times the charging current through a USB port over traditional solutions that translate up to 1.5A via compatible USB host or dedicated charger. In addition, this provides a complete USB charging ecosystem between device and host ports such as Dedicated Charging Port (DCP), Charging (CDP) and Standard (SDP) Downstream Ports.

1.2.3.1 DEVICE FEATURES:

- VBUS Overvoltage Protection
 - Protects internal circuits from VBUS up to 9V
 - Overvoltage/Undervoltage Lockout opens VBUS switch
 - Interrupt to indicate Overvoltage/Undervoltage Lockout
 - Integrated Low R_{DS(on)FET}
- USB Port ESD Protection (DP/DM/VBUS)
 - ±15 kV (air discharge)
 - ±15 kV (contact discharge)
 - IEC 61000-4-2 level 4 ESD protection without external devices
- High-Speed USB Mux for multiplexing the USB lanes between different functions (USB3750 only)
 - Switch the USB connector between two different functions
 - High bandwidth USB switch passes HS USB signals
- Provides USB Battery Charger Detection for:
 - USB-IF Battery Charging compliant Dedicated Charging Ports (DCP)
 - USB-IF Battery Charging compliant Charging Downstream Port (CDP)
 - Standard Downstream Port (SDP); i.e. USB host or downstream hub port
 - Dedicated SE1 type chargers
- Dead Battery Provision Support (USB375x-1 only)
 - Allows 100 mA trickle charging from VBUS when attached to a Standard Downstream Port (SDP) while not enumerated
 - Built-in 100 mA current limiting option
- Microchip RapidCharge Anywhere™ Provides:
 - Three times the charging current through a USB port over traditional solutions
 - USB-IF Battery Charging 1.2 compliance to any portable device
 - Charging current up to 1.5A via compatible USB host or dedicated charger
 - Dedicated Charging Port (DCP), Charging (CDP) & Standard (SDP) Downstream Port support
- flexPWR® Technology
 - Extremely low-current design ideal for battery-powered applications
 - Maximizes power delivered to the system

1.2.4 MCP4562 Device Overview

The MCP4562 Digital Rheostats have typical end-to-end resistances of 5 k Ω , 10 k Ω , 50 k Ω and 100 k Ω at 8 bits of resolution.

The serial interface options allow you to easily integrate the device into your application. The I²C interface allows direct read/write to the wiper register. The I²C interface supports multiple devices on the serial bus without additional pins. Both volatile and nonvolatile (EEPROM) memory is available on the same device, allowing the flexibility to optimize and customize system design.

Low power consumption is an important feature, especially for battery-powered applications. The maximum supply current is only 5 μ A, not including the current for bus access.

Nonvolatile digital potentiometers allow the desired wiper position to be saved during device power-down or brown-out condition. When the device power is restored, the wiper value is loaded from the nonvolatile register, allowing the device to power-on to the desired wiper settings. This is most useful for both applications where the wiper value is programmed once and never changed (system calibration) as well as applications where the last user setting is saved on system power-down (such as setting a regulator output voltage or a volume setting). Mechanical trim pots have been used for device calibration to optimize the system performance. A digital potentiometer with nonvolatile memory can now be a better solution due to its small size and high reliability.

Microchip's nonvolatile digital potentiometers adopt a methodology called WiperLock™ technology, ensuring that once the nonvolatile wiper is "locked," the wiper setting cannot be modified except with "high-voltage" commands. This inhibits accidental modification of the wiper setting during normal operation.

Many of the nonvolatile devices also have some bytes of general purpose EEPROM memory available. This could be used to store system information, such as calibration codes, manufacture date, serial number or user information.

1.2.4.1 DEVICE FEATURES

- Single or Dual Resistor Network Options
- Potentiometer or Rheostat Configuration Options
- Resistor Network Resolution: 8-bit, 256 Resistors (257 Steps)
- R_{AB} Resistances Options of:
 - 5 k Ω
 - 10 k Ω
 - 50 k Ω
 - 100 k Ω
- Zero-Scale to Full-Scale Wiper Operation
- Low Wiper Resistance: 75 Ω (typical)
- Low Tempco:
 - Absolute (Rheostat): 50 ppm typical (0°C to 70°C)
 - Ratiometric (Potentiometer): 15 ppm typical
- Nonvolatile Memory
 - Automatic Recall of Saved Wiper Setting
 - WiperLock™ Technology
 - 10 General Purpose Memory Locations
- I²C Serial Interface
 - 100 kHz, 400 kHz and 3.4 MHz Support

- Serial Protocol Allows:
 - High-Speed Read/Write to Wiper
 - Read/Write to EEPROM
 - Write Protect to be Enabled/Disabled
 - WiperLock to be Enabled/Disabled
- Resistor Network Terminal Disconnect Feature via the Terminal Control (TCON) Register
- Write Protect Feature:
 - Hardware Write Protect (WP) Control Pin
 - Software Write Protect (WP) Configuration Bit
- Brown-out Reset Protection (1.5V typical)
- Serial Interface Inactive Current (2.5 μ A typical)
- High-Voltage Tolerant Digital Inputs: Up to 12.5V
- Wide Operating Voltage:
 - 2.7V to 5.5V - Device Characteristics Specified
 - 1.8V to 5.5V - Device Operation
- Wide Bandwidth (-3 dB) Operation:
 - 2 MHz (typical) for 5.0 k Ω Device

1.2.5 PAC1710 Device Overview

The PAC1710/20 are single and dual high-side bidirectional current sensing monitors with precision voltage measurement capabilities. Each sensor measures the voltage developed across an external sense resistor to represent the high-side current of a battery or voltage regulator. The PAC1710/20 also measures the SENSE+ pin voltage and calculates average power over the integration period. The PAC1710/20 can be programmed to assert the ALERT pin when high and low limits are exceeded for Current Sense and Bus Voltage. The PAC1710/20 device is good for measuring dynamic power. The long integration time allows for extending system polling cycles without losing any power consumption information. In addition, the alert ensures that transient events are captured between the polling cycles.

1.2.5.1 DEVICE FEATURES:

- Single and Dual High-Side Current Sensor
 - Current measurement is integrated over 2.5 ms to 2.6s with up to 11-bit resolution
 - 1% current measurement accuracy in positive range
 - Measures V_{SOURCE} voltages
- Calculates Power
- V_{SOURCE} Voltage Range 0V to 40V
- Bidirectional Current Sensing
- Auto-Zero Input Offset Voltage
- Digital Averaging
 - Adjustable sampling time and resolution
- 5 μ A Typical Standby Current
- Programmable Sense Voltage Range
 - ± 10 mV, ± 20 mV, ± 40 mV, and ± 80 mV
- Power Supply Range 3.0V to 5.5V
- ALERT Output for Voltage and Current out of Limit Transients Between Sampling Interval

- SMBus 2.0 Communications Interface
 - Block Read and Block Write
 - Address selectable by resistor decode
- Sample Time Configurable from 2.5 ms to 320 ms
 - With averaging effective sampling times up to 2.6 s

1.3 THE MCP1663 USB PROGRAMMABLE POWER SUPPLY

The MCP1663 USB Programmable Power Supply is used to demonstrate interfunctionality between a broad range of analog and digital Microchip devices, by means of a real life application: a complete and programmable power supply.

The compact packaging and high integration of the Microchip ICs fitted on the board allows the entire solution to be very small, the size of common USB FLASH Stick.

Voltage regulation is performed by the MCP1663 in SEPIC configuration. This topology allows the user to both step up and step down the 5V USB input voltage to a regulated output between 2.5V and 30V.

The coupled SEPIC inductor solution requires a smaller PCB area and reduces radiated electromagnetic interference (EMI). Another advantage of using a coupled inductor is the fact that only half of the calculated inductance is needed. A capacitor connected between the first inductor and the second inductor offers DC isolation and protection against a shorted load. The capacitor clamps the winding leakage inductance energy and eliminates the need for a snubber circuit. The input inductor smooths the current draw and reduces the required input filtering.

Setting the regulated output voltage is done by the MCP4562 Digital Rheostat, which is programmed via I²C to adjust the feedback voltage divider ratio.

On the output side, the PAC1710 senses the output voltage level and load current, then reports the values via I²C access.

The MCP2221 acts as I²C master to the above and USB bridge. This allows the user to freely program the output voltage and read back the load current. Since the output voltage is also measured, the application automatically fine tunes the output to match the voltage to the desired selection.

In order to negotiate maximum current from the PC USB charging port and also to provide surge protection, the USB3751 is managing the Power Supply's interface to USB.

The application described is not limited to PC USB input. Once the nonvolatile memory of the MCP4562 is programmed with the desired output voltage, the Power Supply can be connected to any USB power source (i.e., wall plug, USB car charger, etc.)

1.4 WHAT THE MCP1663 USB PROGRAMMABLE POWER SUPPLY KIT CONTAINS

The MCP1663 USB Programmable Power Supply kit includes:

- MCP1663 USB Programmable Power Supply (ARD00698)
- Important Information Sheet

Chapter 2. Installation and Operation

2.1 INTRODUCTION

The MCP1663 USB Programmable Power Supply provides a versatile and easy-to-use power supply solution for engineers. Whether supplied from a USB port of the computer or a wall plug, it delivers a wide range output voltage, from 2.5V to 30V.

Thanks to the on-board High-Speed USB switch, the MCP1663 USB Programmable Power Supply can draw up to 1.5A from the USB host/wall plug.

An application with a simple GUI allows for quick voltage setting, as well as power measurement.

Before using the power supply with a wall plug, the user must first program the output voltage through the application. An EEPROM stores the value, until reprogrammed to a different one.

The reduced dimensions (the size of a USB flash stick) is key for portability.

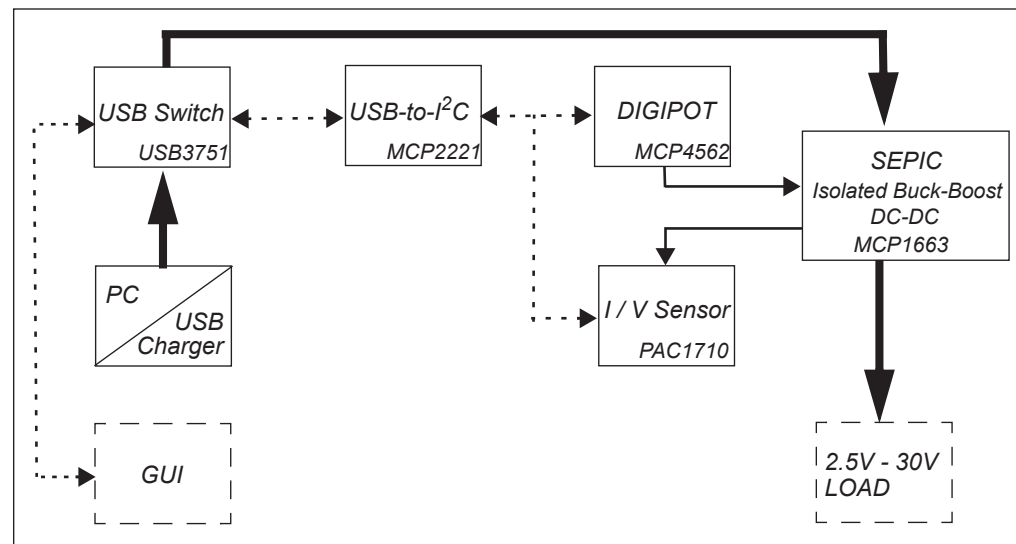

FIGURE 2-1: MCP1663 USB Programmable Power Supply Functional Blocks.

2.2 MCP1663 USB PROGRAMMABLE POWER SUPPLY FEATURES

2.2.1 Board Features

- 2.5V to 30V programmable output voltage (0.5V increments)
- Up to 1.5A peak input current
- Automatic disconnect in case of short circuit
- Nonvolatile memory for output voltage storing
- Output power measurement (voltage/current)

2.2.2 Application Features

- 2.5V to 30V programmable output voltage (by track bar and numeric input)
- Overload indication
- Instant output power indication
- Multiple device support with individual programming
- Self calibration for precise voltage output
- Emergency STOP button

2.3 GETTING STARTED

Plug the MCP1663 USB Programmable Power Supply into any USB port of the PC and wait for the drivers to install. The “Your device is ready to use” pop-up message displays, signaling the device drivers are installed and the GUI is safe for launch.

Once powered, the MCP1663 USB Programmable Power Supply will source the last stored output voltage (regardless of the application being started or not). If there is no LED activity and the output voltage read is 0V, the device is disabled by software. Refer to [Chapter 4. “GUI Description”](#) for operation instructions.

To set the output voltage to a new desired level or to monitor output voltage and current, the MCP1663 USB Programmable Power Supply must be plugged into a USB port or preferably into a USB charging port, for maximum current capabilities.

2.4 OPERATION

After installing the application, run the “USB_Programmable_PS.exe.” The GUI will launch to an idle operation (see [Chapter 4. “GUI Description”](#)). The MCP1663 USB Programmable Power Supply overview is depicted in [Figure 2-2](#).

The board is supplied from the USB type A, while the regulated output voltage is accessible on the output terminal block.

A green LED indicates the Output Status. It switches ON, when the user activates the MCP1663 SEPIC regulator. If the regulator is disabled from the GUI (see [Chapter 4. “GUI Description”](#)), the output voltage drops to 0V and the green LED switches OFF.

A red LED indicates whether an over-current situation has occurred (ALERT). It switches ON when a current surge is detected on the MCP1663 USB Programmable Power Supply input. The ALERT remains active until a power cycle is performed.

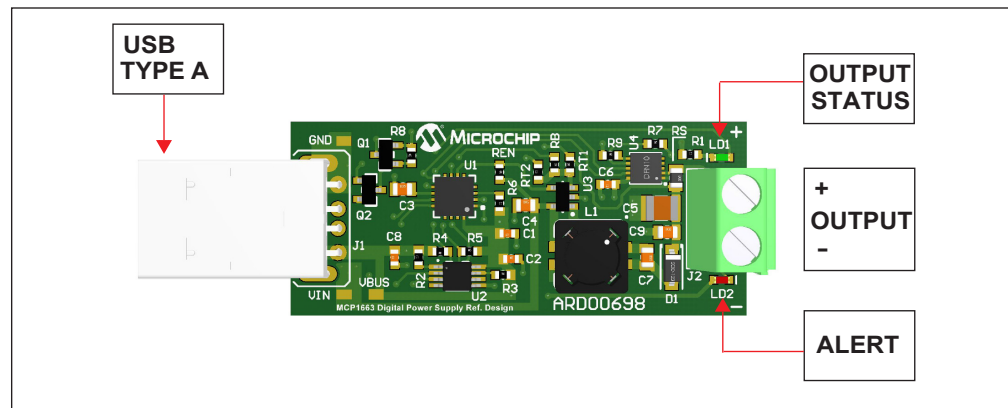

FIGURE 2-2: The MCP1663 USB Programmable Power Supply Overview.

Chapter 3. GUI Installation and Operation

3.1 GETTING STARTED

In order to install, use and evaluate the product, there are several software and hardware tools required to be installed and/or configured.

3.1.1 Required Software

- USB Programmable Power Supply GUI (minimum v.1.0.0)
- Microsoft® .NET Framework 4.5 or Higher
- Microsoft® Windows® 7

3.1.2 Required Hardware

- MCP1663 USB Programmable Power Supply

3.2 GRAPHICAL USER INTERFACE INSTALLATION

The following steps describe how to install the USB Programmable Power Supply GUI:

1. If Microsoft .NET Framework is already installed, go to [Step 2](#). If not, download Microsoft .NET Framework from www.microsoft.com and follow the installation instructions.
2. Download the USB Programmable Power Supply GUI (v.1.0.0) archive from www.microchip.com/DevelopmentTools/ProductDetails.aspx?PartNO=ARD00698.
3. Unzip the USB Programmable Power Supply GUI archive, which contains the `UsbProgrammablePowerSupply-v1.0.0-windows-installer.exe` file.
4. Double click on the file to open the InstallShield Wizard window and wait for the extraction to complete. If required, the installation can be stopped by clicking the **Cancel** button.

5. In the Welcome to the InstallShield Wizard, click the **Next** button to start the installation.

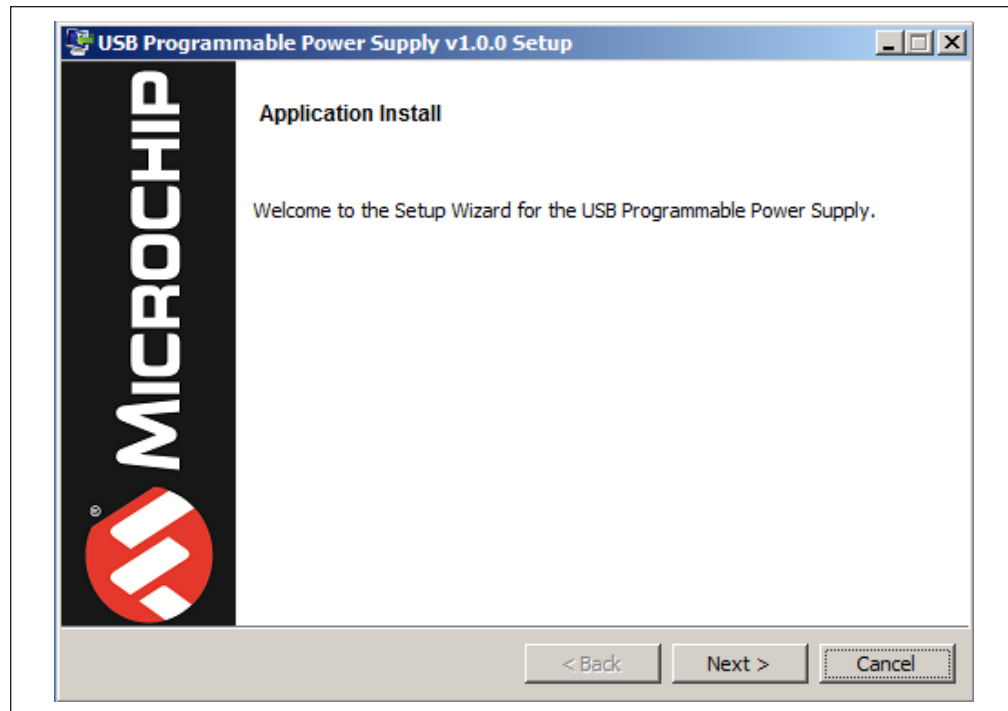

FIGURE 3-1: Starting the MCP1663 USB Programmable Power Supply GUI Installation.

6. Read the License Agreement. Select the "I accept the agreement" option in order to proceed. Click on the **Next** button to continue.

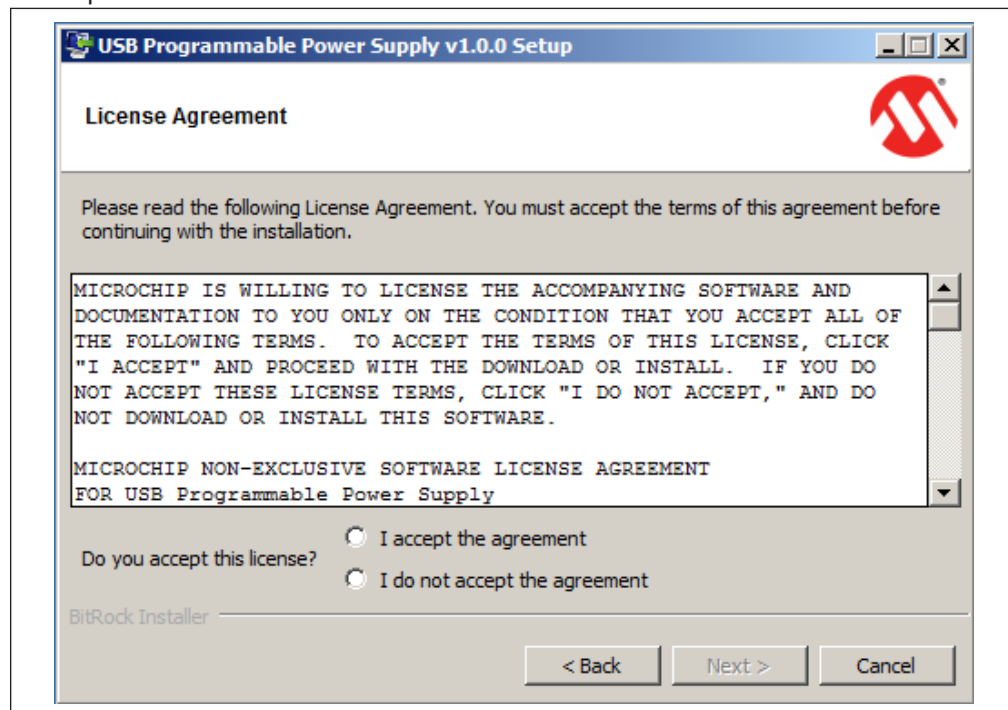

FIGURE 3-2: The MCP1663 USB Programmable Power Supply GUI Installation.

- The installation path can be changed, although it is recommended to keep the default path. Click on the **Next** button to continue.

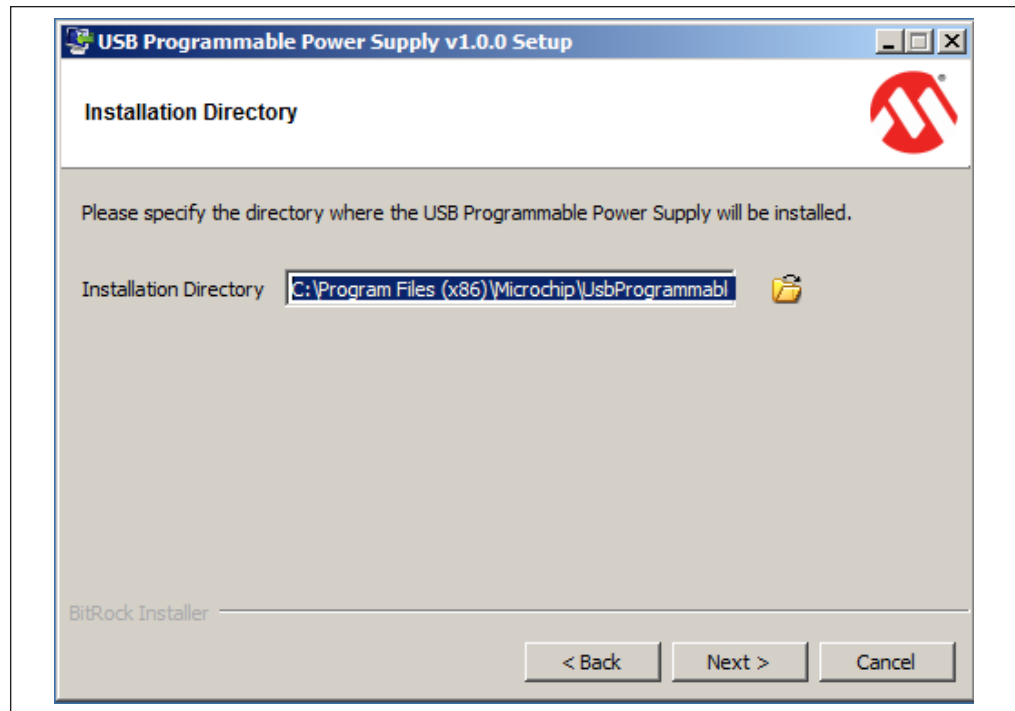

FIGURE 3-3: Selecting the Destination Folder.

- In the Ready to Install window, click on the **Next** button and wait for the application to proceed with the installation. The progress can be observed in the "Status" bar.

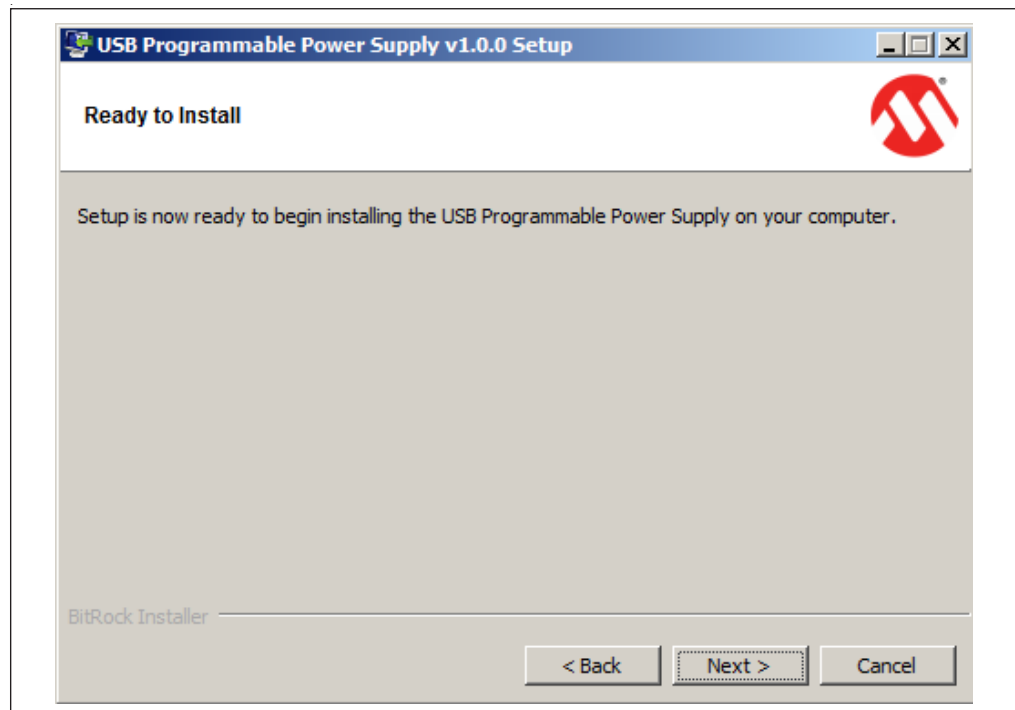

FIGURE 3-4: Installing the MCP1663 USB Programmable Power Supply GUI.

9. Once the installation completes, select the **View Release Notes File** check box to view release notes and revision history, or deselect this check box to skip. Click the **Finish** button to complete the installation.

To start the GUI, either click on the desktop icon or navigate to Windows Start>All Programs>Microchip>USB Programmable Power Supply>USB Programmable Power Supply.

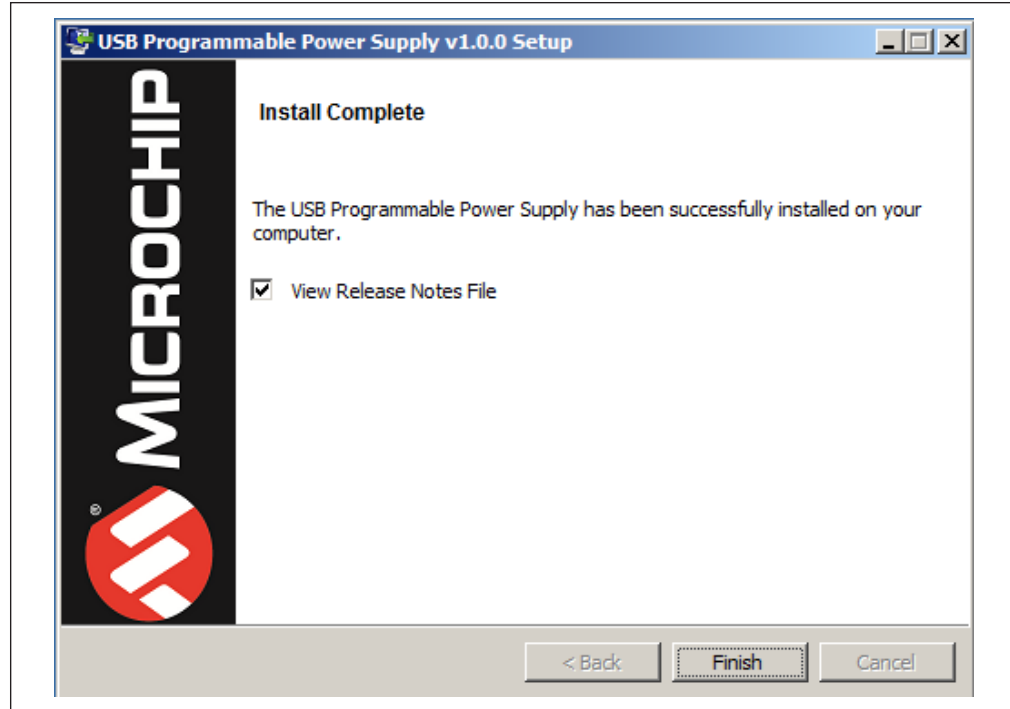

FIGURE 3-5: The Installation Complete Window.

3.3 MCP1663 USB PROGRAMMABLE POWER SUPPLY GUI UNINSTALL

In order to install a new version of the MCP1663 USB Programmable Power Supply GUI, any previous or corrupted versions should be removed from the computer.

To uninstall, go to Windows Start>All Programs>Microchip>USB Programmable Power Supply>Uninstall USB Programmable Power Supply. Click the **Yes** button to remove the application from the PC.

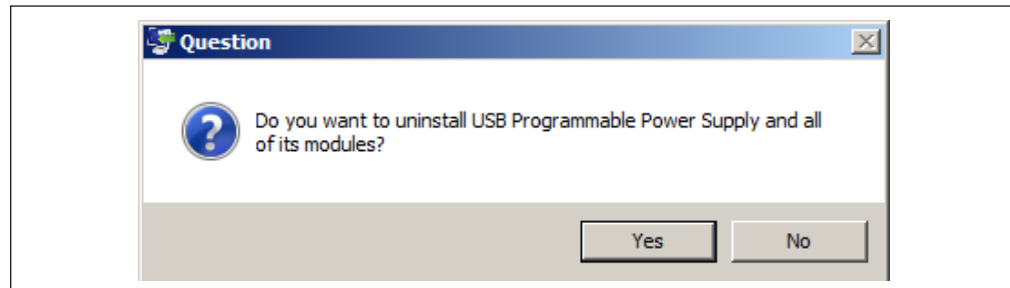

FIGURE 3-6: Uninstall the MCP1663 USB Programmable Power Supply GUI.

When the uninstallation is complete, a pop-up displays confirming the successful uninstallation. Click the **OK** button to exit.

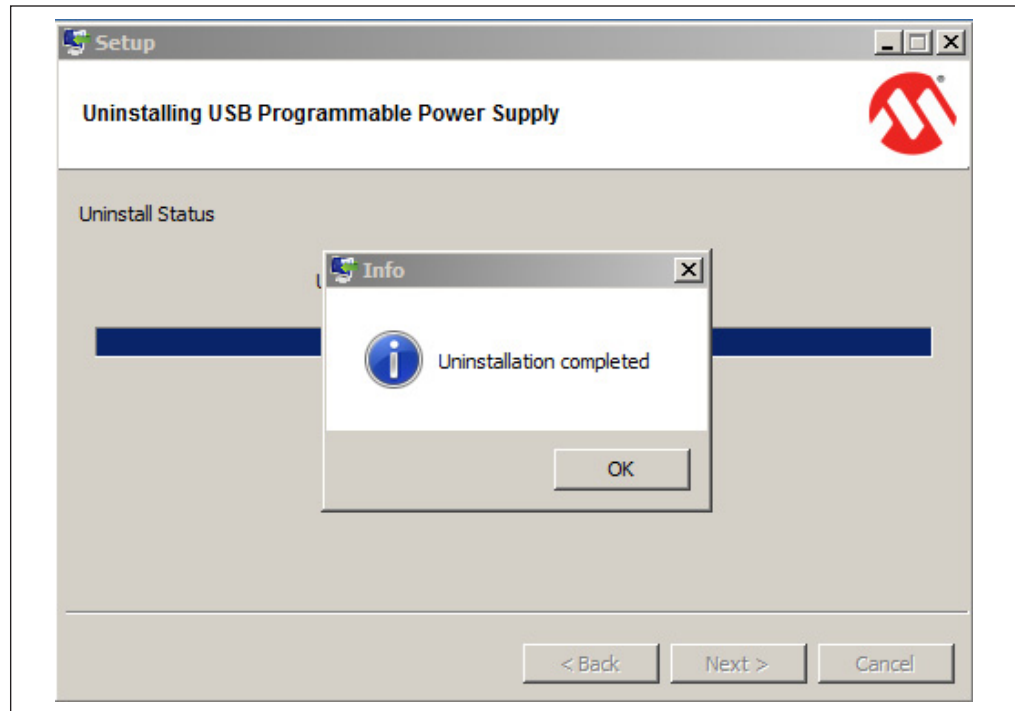

FIGURE 3-7: GUI Uninstall Complete.

NOTES:

Chapter 4. GUI Description

4.1 INTRODUCTION

After installing the application, run the `USB_Programmable_PS.exe` file. The GUI will launch to an idle operation. If the MCP1663 is connected to one of the USB ports, then the GUI displays "Device Connected." Otherwise, it displays "Device Disconnected."

4.2 THE GRAPHICAL USER INTERFACE

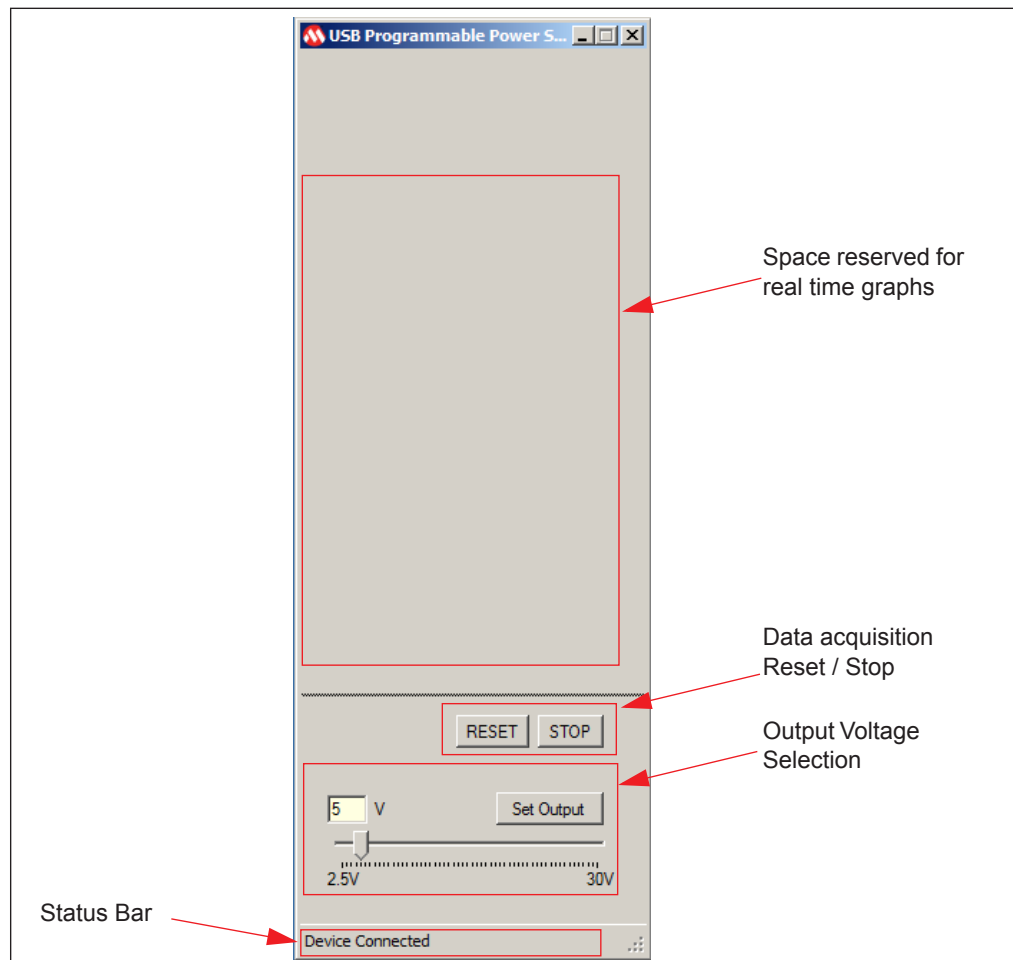

FIGURE 4-1: Power-up View of the GUI.

After checking that the MCP1663 USB Programmable Power Supply is attached, set the output voltage to the desired level, between 2.5V and 30V. This can be done by numeric input or simply sliding the track bar.

Clicking the **Set Output** button triggers the regulator into operation (if idle) or readjusts the output according to the selected voltage. During operation, the voltage and current graphs generate in real time, along with the output power calculation. On the board, the Green LED turns ON to show that the output is powered.

Click the **STOP** button to disable the voltage regulator and discharge the output to 0V. Data acquisition for real time graphs can be halted by clicking the **STOP** button again, while the output voltage discharge is below 0.1V. The output can be activated again by clicking the **Set Output** button. Data acquisition for real time graphs also resumes.

An important feature of the application is that it automatically fine tunes the output voltage to match the desired voltage setting. This is possible by sensing the voltage close to the output of the MCP1663 USB Programmable Power Supply and incrementing the voltage level in steps, until minimum deviation from target voltage is reached.

The **RESET** button allows the user to remove all previous acquired data for the graphs. This does not affect the voltage regulation, fine tuning of output setting.

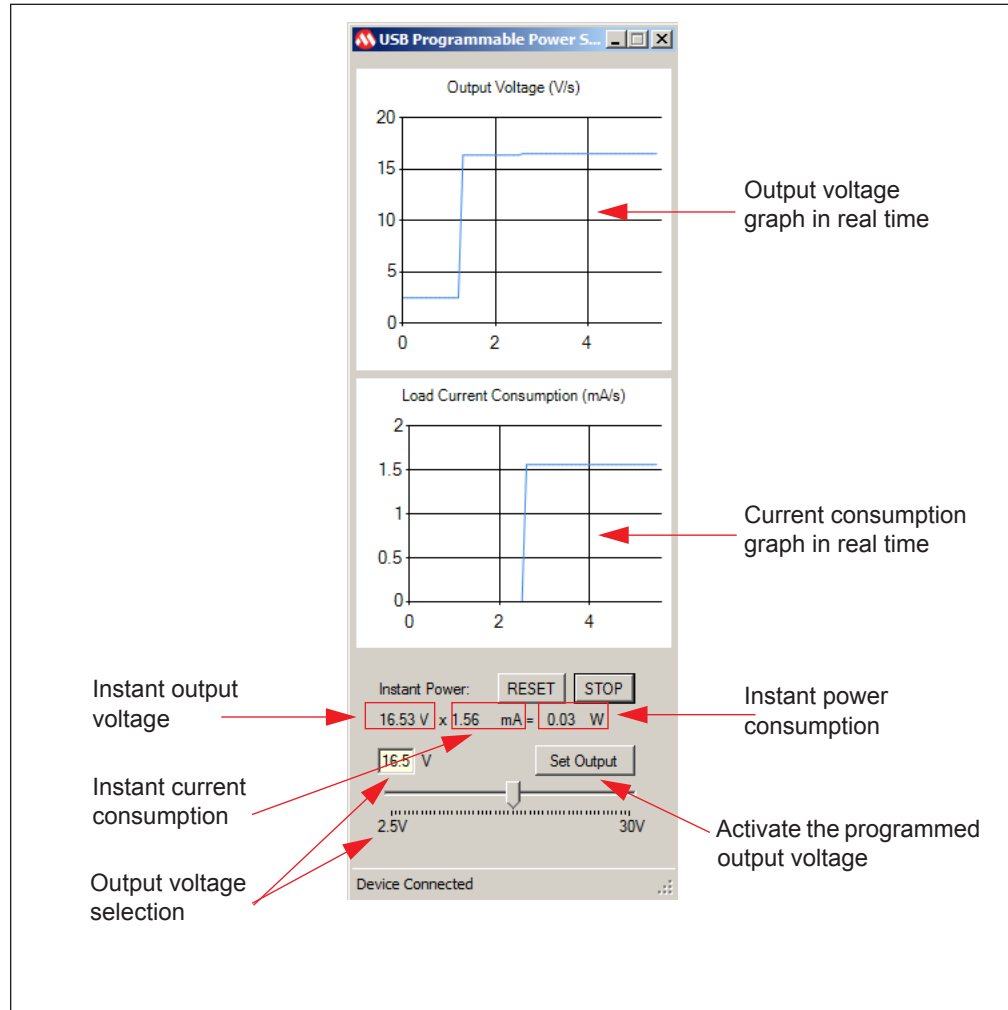

FIGURE 4-2: MCP1663 USB Programmable Power Supply GUI Operation.



MCP1663 USB PROGRAMMABLE POWER SUPPLY REFERENCE DESIGN USER'S GUIDE

Appendix A. Schematics and Layouts

A.1 INTRODUCTION

This appendix contains the following schematics and layouts for the MCP1663:

- Board – Schematic
- Board – Top Silk
- Board – Top Copper and Silk
- Board – Top Copper
- Board – Bottom Copper
- Board – Bottom Copper and Silk
- Board – Bottom Silk

A.2 BOARD – SCHEMATIC

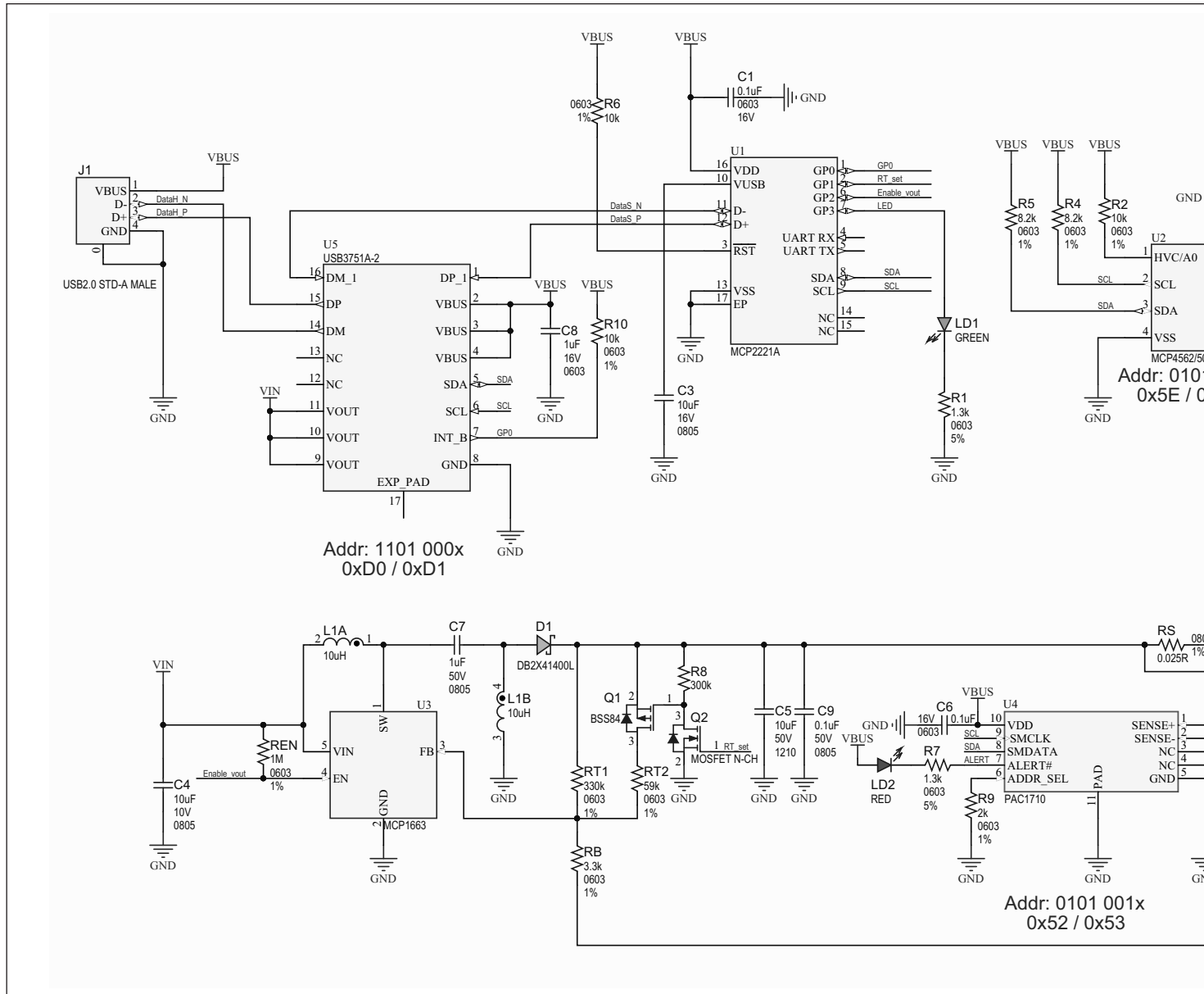

A.3 BOARD – TOP SILK

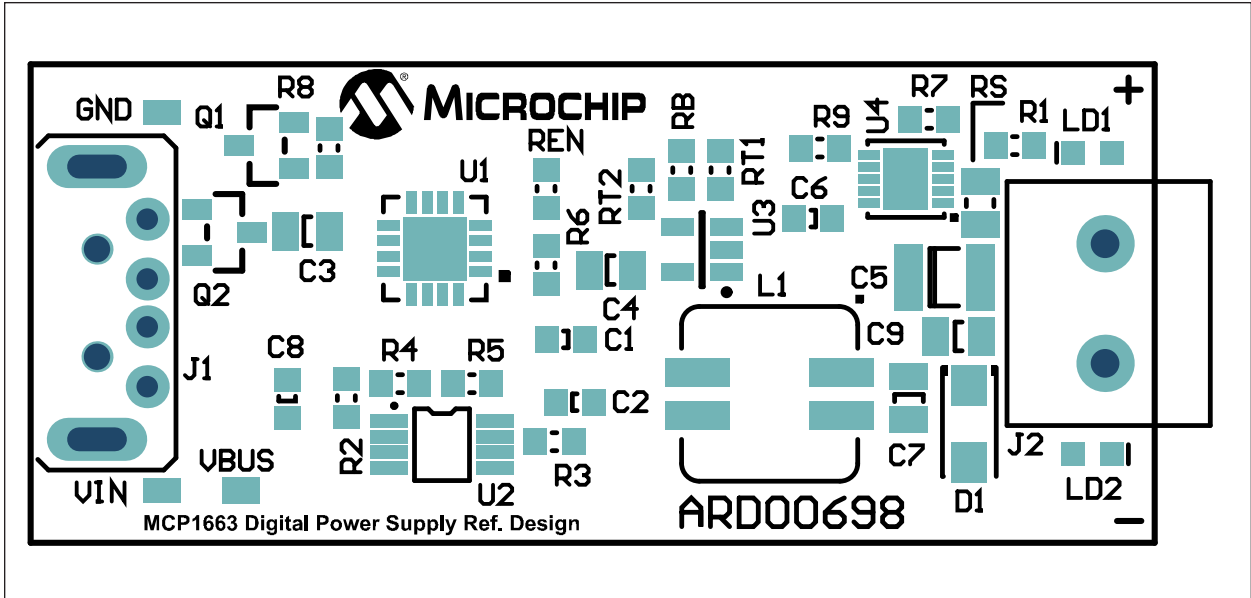

A.4 BOARD – TOP COPPER AND SILK

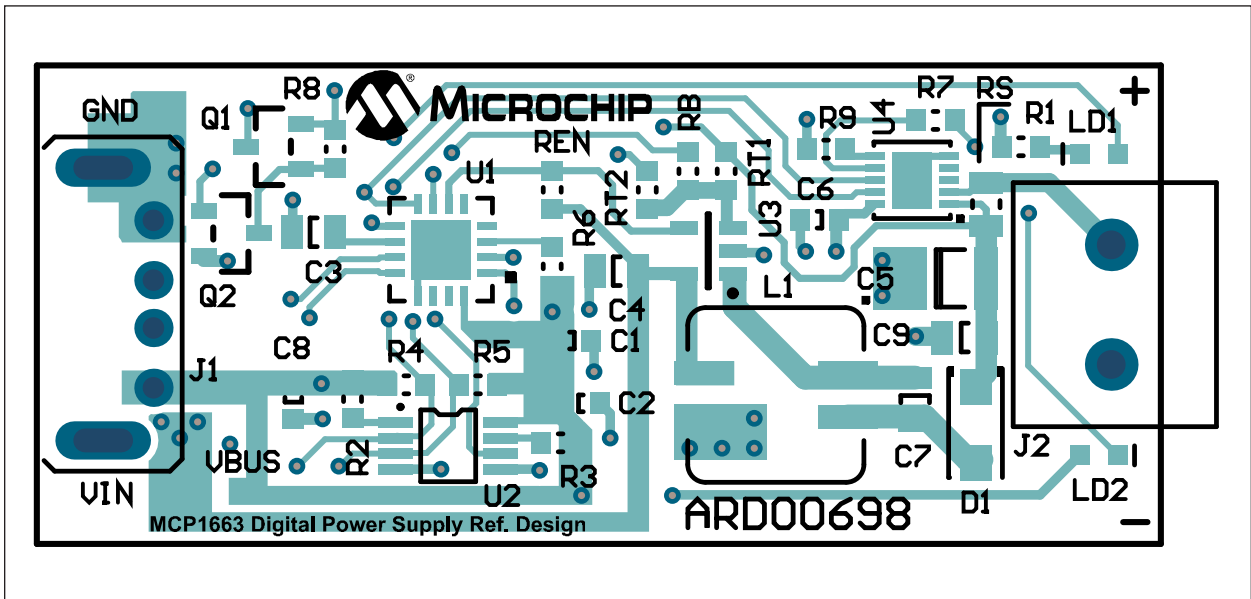

A.5 BOARD – TOP COPPER

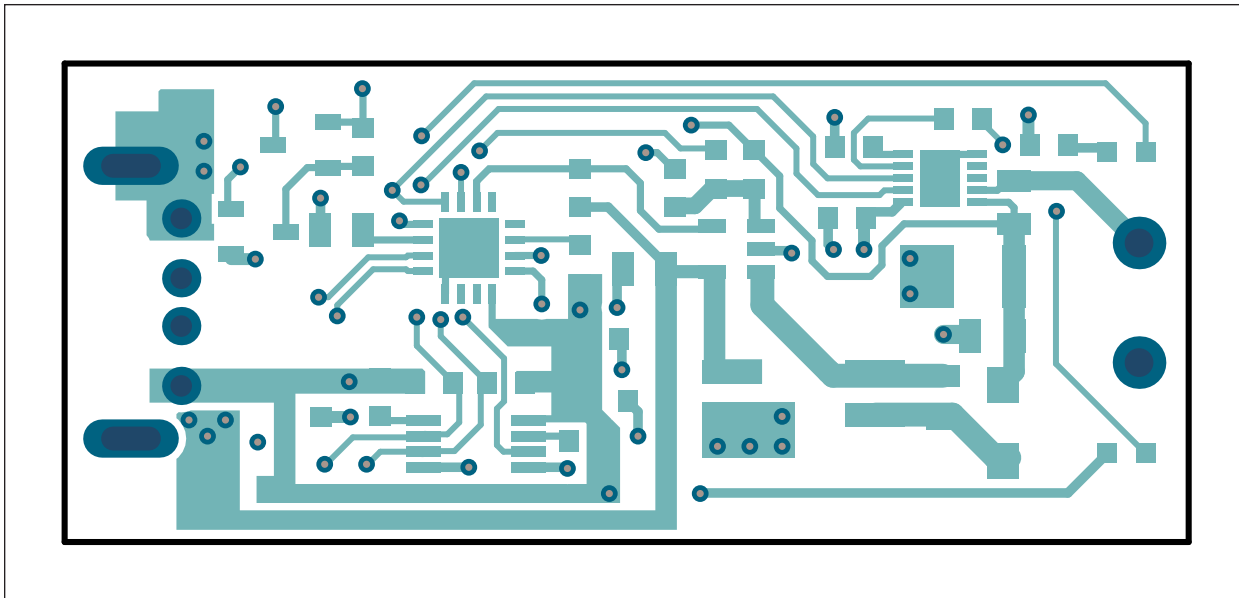

A.6 BOARD – BOTTOM COPPER

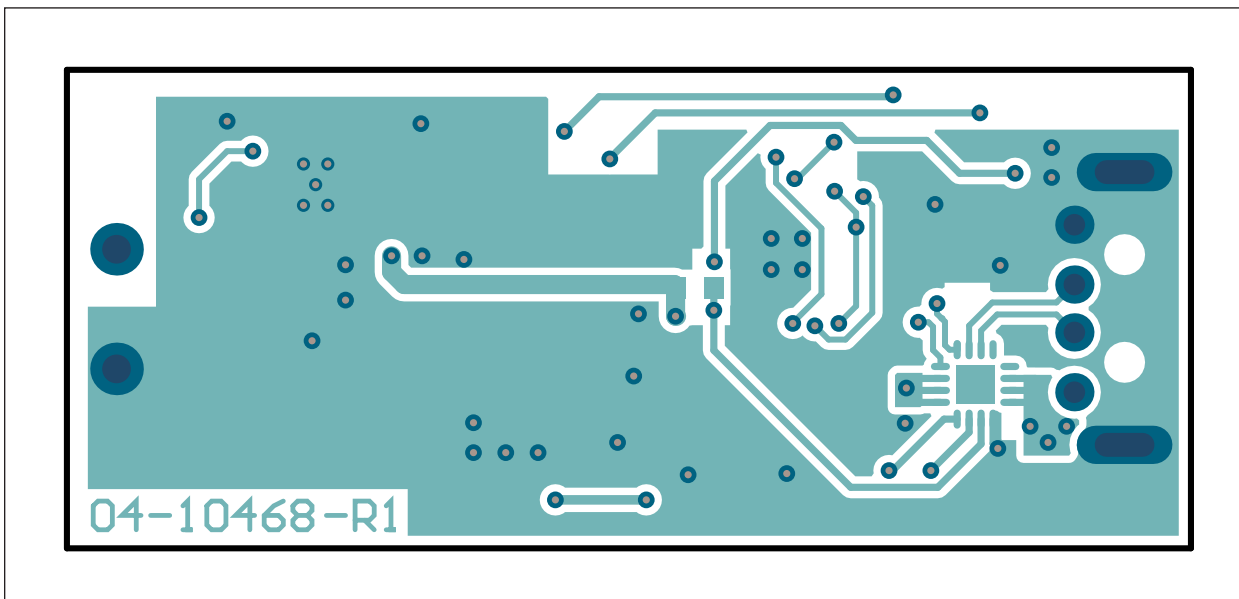

A.7 BOARD – BOTTOM COPPER AND SILK

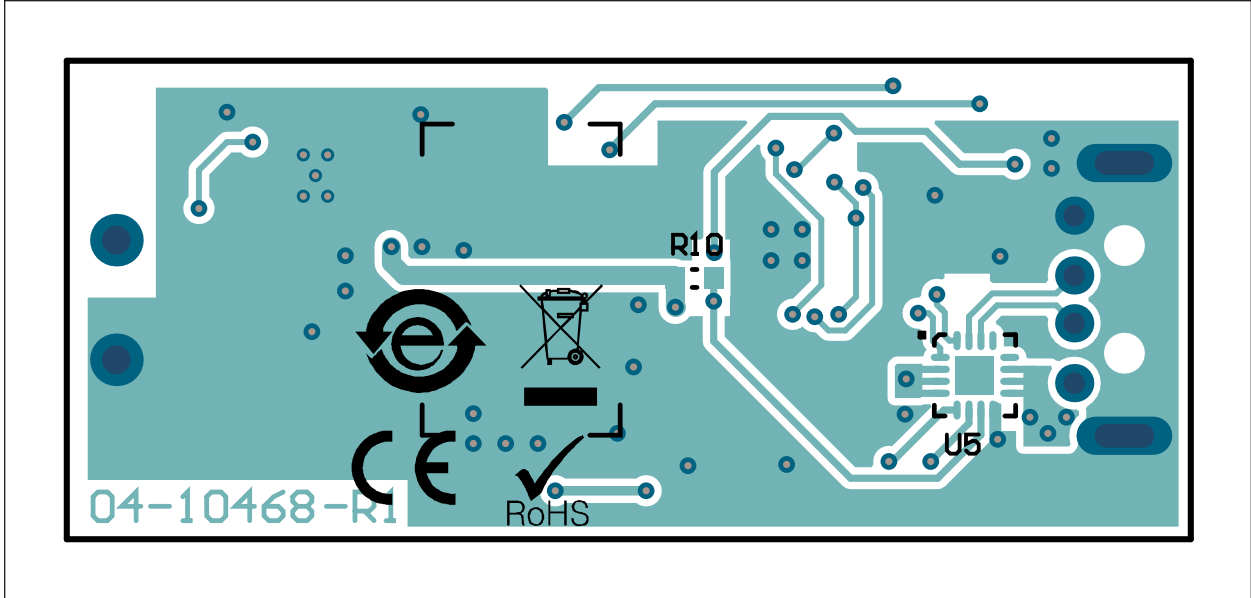

A.8 BOARD – BOTTOM SILK

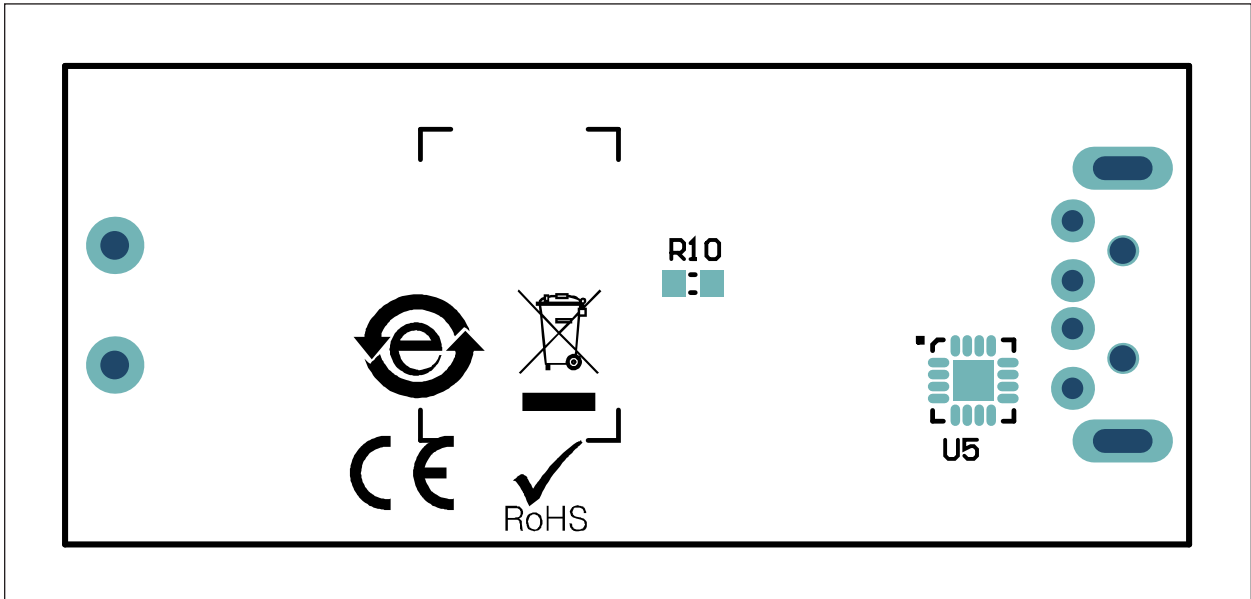

NOTES:



MCP1663 USB PROGRAMMABLE POWER SUPPLY REFERENCE DESIGN USER'S GUIDE

Appendix B. Bill of Materials (BOM)

TABLE B-1: BILL OF MATERIALS (BOM)

Qty.	Reference	Description	Manufacturer	Part Number
3	C1, C2, C6	Capacitor ceramic, 0.1 μ F, 16V, 10%, X7R, SMD, 0603	Wurth Elektronik	885012206046
1	C3	Capacitor ceramic, 10 μ F, 16V, 10%, X5R, SMD, 0805	Wurth Elektronik	885012107014
1	C4	Capacitor ceramic, 10 μ F, 10V, 10%, X5R, SMD, 0805	Taiyo Yuden Co., Ltd.	LMK212BJ106KG-T
1	C5	Capacitor ceramic, 10 μ F, 50V, 20%, X7S, SMD, 1210	TDK Corporation	C3225X7S1H106M
1	C7	Capacitor ceramic, 1 μ F, 50V, 20%, Y5V, SMD, 0805	Samsung, Inc.	CL21F105ZBFNNE
1	C8	Capacitor ceramic, 1 μ F, 16V, 10%, X5R, SMD, 0603	AVX Corporation	0603YD105KAT2A
1	C9	Capacitor ceramic, 0.1 μ F, 50V, 10%, X7R, SMD, 0805	Cal-Chip Electronics Inc.	GMC21X7R104K50NTLF
1	D1	Diode SCKY DB2X41400L, 490 mV, 2A, 40V, SMD, SOD-123F	Panasonic® - ECG	DB2X41400L
1	J1	Connector USB2.0, STD-A, Male, TH, R/A	Molex®	0480370001
1	J2	Connector TERMINAL, 5 mm 1x2, Female, 12-26AWG, 18A, TH, R/A	PHOENIX CONTACT	1935161
1	L1	Inductor, 10 μ H, 1.1A, 20%, SMD, L7.3W7.3H4	Wurth Elektronik	744877100
1	LABEL1	Label, AIPD Board Assembly		
1	LD1	Diode LED, Green, 2V, 30 mA, 35mcd, Clear, SMD, 0603	Lite-On®, Inc.	LTST-C191KGKT
1	LD2	Diode LED, Red, 2V, 30 mA, 2mcd, Clear, SMD, 0603	Lite-On®, Inc.	LTST-C190EKT
4	PAD1, PAD2, PAD3, PAD4	Mechanical HW rubber pad, cylindrical, D7.9, H5.3, Black	3M	SJ61A11
1	PCB	Printed Circuit Board – MCP1663 USB Programmable Power Supply Reference Design	Microchip Technology Inc.®	04-10468-R1
1	Q1	TRANS FET, P-CH, BSS84, -50V, -130 mA, 300 mW, SOT-23-3	Diodes Incorporated®	BSS84-7-F
1	Q2	TRANS FET, N-CH, NDS7002A, 60V, 280 mA, 2R, 0.3W, SOT-23-3	Fairchild Semiconductor®	NDS7002A
2	R1, R7	Resistor, TKF, 1.3k, 5%, 1/10W, SMD, 0603	Panasonic® - ECG	ERJ-3GEYJ132V
4	R2, R3, R6, R10	Resistor, TKF, 10k, 1%, 1/16W, SMD, 0603	TE Connectivity, Ltd.	5-1879337-9
2	R4, R5	Resistor, TKF, 8.2k, 1%, 1/10W, SMD, 0603	Panasonic® - ECG	ERJ-3EKF8201V

Note: The components listed in this Bill of Materials are representative of the PCB assembly. The released BOM used in manufacturing uses all RoHS-compliant components.

TABLE B-1: BILL OF MATERIALS (BOM) (CONTINUED)

Qty.	Reference	Description	Manufacturer	Part Number
1	R8	Resistor, TKF, 300k, 1%, 1/10W, SMD, 0603	Panasonic® - ECG	ERJ-3EKF3003V
1	R9	Resistor, TKF, 2k, 1%, 1/10W, SMD, 0603	Panasonic® - ECG	ERJ-3EKF2001V
1	RB	Resistor, TKF, 3.3k, 1%, 1/10W, SMD, 0603	Panasonic® - ECG	ERJ-3EKF3301V
1	REN	Resistor, TKF, 1M, 1%, 1/10W, SMD, 0603	Panasonic® - ECG	ERJ-3EKF1004V
1	RS	Resistor, TKF, 0.025R, 1%, 1/2W, SMD, 0805	Panasonic® - ECG	ERJ-6BWFR025V
1	RT1	Resistor, TKF, 330k, 1%, 1/10W, SMD, 0603	Panasonic® - ECG	ERJ-3EKF3303V
1	RT2	Resistor, TKF, 59k, 1%, 1/10W, SMD, 0603	Panasonic® - ECG	ERJ-3EKF5902V
1	U1	Microchip Interface USB I2C/UART MCP2221A-I/ML QFN-16	Microchip Technology Inc.®	MCP2221A-I/ML
1	U2	Microchip Analog Digipot 1-Ch 50k MCP4562-503E/MS MSOP-8	Microchip Technology Inc.®	MCP4562-503E/MS
1	U3	Microchip Analog Switcher Boost 32V MCP1663T-E/OT SOT-23-5	Microchip Technology Inc.®	MCP1663T-E/OT
1	U4	Microchip Analog Current Sense Monitor PAC1710-1-AIA-TR DFN-10	Microchip Technology Inc.®	PAC1710-1-AIA-TR
1	U5	Microchip USB2.0 Protection IC with Battery Charger Detection USB3751A-2-A4-TR QFN-16	Microchip Technology Inc.®	USB3751A-2-A4-TR-ND

Note: The components listed in this Bill of Materials are representative of the PCB assembly. The released BOM used in manufacturing uses all RoHS-compliant components.



MICROCHIP

Worldwide Sales and Service

AMERICAS

Corporate Office
2355 West Chandler Blvd.
Chandler, AZ 85224-6199
Tel: 480-792-7200
Fax: 480-792-7277
Technical Support:
<http://www.microchip.com/support>
Web Address:
www.microchip.com

Atlanta

Duluth, GA
Tel: 678-957-9614
Fax: 678-957-1455

Austin, TX

Tel: 512-257-3370

Boston

Westborough, MA
Tel: 774-760-0087
Fax: 774-760-0088

Chicago

Itasca, IL
Tel: 630-285-0071
Fax: 630-285-0075

Dallas

Addison, TX
Tel: 972-818-7423
Fax: 972-818-2924

Detroit

Novi, MI
Tel: 248-848-4000

Houston, TX

Tel: 281-894-5983

Indianapolis

Noblesville, IN
Tel: 317-773-8323
Fax: 317-773-5453
Tel: 317-536-2380

Los Angeles

Mission Viejo, CA
Tel: 949-462-9523
Fax: 949-462-9608
Tel: 951-273-7800

Raleigh, NC

Tel: 919-844-7510

New York, NY

Tel: 631-435-6000

San Jose, CA

Tel: 408-735-9110
Tel: 408-436-4270

Canada - Toronto

Tel: 905-695-1980
Fax: 905-695-2078

ASIA/PACIFIC

Australia - Sydney
Tel: 61-2-9868-6733

China - Beijing
Tel: 86-10-8569-7000

China - Chengdu
Tel: 86-28-8665-5511

China - Chongqing
Tel: 86-23-8980-9588

China - Dongguan
Tel: 86-769-8702-9880

China - Guangzhou
Tel: 86-20-8755-8029

China - Hangzhou
Tel: 86-571-8792-8115

China - Hong Kong SAR
Tel: 852-2943-5100

China - Nanjing
Tel: 86-25-8473-2460

China - Qingdao
Tel: 86-532-8502-7355

China - Shanghai
Tel: 86-21-3326-8000

China - Shenyang
Tel: 86-24-2334-2829

China - Shenzhen
Tel: 86-755-8864-2200

China - Suzhou
Tel: 86-186-6233-1526

China - Wuhan
Tel: 86-27-5980-5300

China - Xian
Tel: 86-29-8833-7252

China - Xiamen
Tel: 86-592-2388138

China - Zhuhai
Tel: 86-756-3210040

ASIA/PACIFIC

India - Bangalore
Tel: 91-80-3090-4444

India - New Delhi
Tel: 91-11-4160-8631

India - Pune
Tel: 91-20-4121-0141

Japan - Osaka
Tel: 81-6-6152-7160

Japan - Tokyo
Tel: 81-3-6880-3770

Korea - Daegu
Tel: 82-53-744-4301

Korea - Seoul
Tel: 82-2-554-7200

Malaysia - Kuala Lumpur
Tel: 60-3-7651-7906

Malaysia - Penang
Tel: 60-4-227-8870

Philippines - Manila
Tel: 63-2-634-9065

Singapore
Tel: 65-6334-8870

Taiwan - Hsin Chu
Tel: 886-3-577-8366

Taiwan - Kaohsiung
Tel: 886-7-213-7830

Taiwan - Taipei
Tel: 886-2-2508-8600

Thailand - Bangkok
Tel: 66-2-694-1351

Vietnam - Ho Chi Minh
Tel: 84-28-5448-2100

EUROPE

Austria - Wels
Tel: 43-7242-2244-39
Fax: 43-7242-2244-393

Denmark - Copenhagen
Tel: 45-4450-2828
Fax: 45-4485-2829

Finland - Espoo
Tel: 358-9-4520-820

France - Paris
Tel: 33-1-69-53-63-20
Fax: 33-1-69-30-90-79

Germany - Garching
Tel: 49-8931-9700

Germany - Haan
Tel: 49-2129-3766400

Germany - Heilbronn
Tel: 49-7131-67-3636

Germany - Karlsruhe
Tel: 49-721-625370

Germany - Munich
Tel: 49-89-627-144-0
Fax: 49-89-627-144-44

Germany - Rosenheim
Tel: 49-8031-354-560

Israel - Ra'anana
Tel: 972-9-744-7705

Italy - Milan
Tel: 39-0331-742611
Fax: 39-0331-466781

Italy - Padova
Tel: 39-049-7625286

Netherlands - Drunen
Tel: 31-416-690399
Fax: 31-416-690340

Norway - Trondheim
Tel: 47-7289-7561

Poland - Warsaw
Tel: 48-22-3325737

Romania - Bucharest
Tel: 40-21-407-87-50

Spain - Madrid
Tel: 34-91-708-08-90
Fax: 34-91-708-08-91

Sweden - Gothenberg
Tel: 46-31-704-60-40

Sweden - Stockholm
Tel: 46-8-5090-4654

UK - Wokingham
Tel: 44-118-921-5800
Fax: 44-118-921-5820

X-ON Electronics

Largest Supplier of Electrical and Electronic Components

Click to view similar products for [Power Management IC Development Tools](#) category:

Click to view products by [Microchip](#) manufacturer:

Other Similar products are found below :

[EVB-EP5348UI](#) [MIC23451-AAAYFL EV](#) [MIC5281YMME EV](#) [124352-HMC860LP3E](#) [DA9063-EVAL](#) [ADP122-3.3-EVALZ](#) [ADP130-0.8-EVALZ](#) [ADP130-1.8-EVALZ](#) [ADP1740-1.5-EVALZ](#) [ADP1870-0.3-EVALZ](#) [ADP1874-0.3-EVALZ](#) [ADP199CB-EVALZ](#) [ADP2102-1.25-EVALZ](#) [ADP2102-1.875EVALZ](#) [ADP2102-1.8-EVALZ](#) [ADP2102-2-EVALZ](#) [ADP2102-3-EVALZ](#) [ADP2102-4-EVALZ](#) [AS3606-DB](#) [BQ25010EVM](#) [BQ3055EVM](#) [ISLUSBI2CKIT1Z](#) [LP38512TS-1.8EV](#) [EVAL-ADM1186-1MBZ](#) [EVAL-ADM1186-2MBZ](#) [ADP122UJZ-REDYKIT](#) [ADP166Z-REDYKIT](#) [ADP170-1.8-EVALZ](#) [ADP171-EVALZ](#) [ADP1853-EVALZ](#) [ADP1873-0.3-EVALZ](#) [ADP198CP-EVALZ](#) [ADP2102-1.0-EVALZ](#) [ADP2102-1-EVALZ](#) [ADP2107-1.8-EVALZ](#) [ADP5020CP-EVALZ](#) [CC-ACC-DBMX-51](#) [ATPL230A-EK](#) [MIC23250-S4YMT EV](#) [MIC26603YJL EV](#) [MIC33050-SYHL EV](#) [TPS60100EVM-131](#) [TPS65010EVM-230](#) [TPS71933-28EVM-213](#) [TPS72728YFFEVM-407](#) [TPS79318YEQEVM](#) [UCC28810EVM-002](#) [XILINXPWR-083](#) [LMR22007YMINI-EVM](#) [LP38501ATJ-EV](#)