I²C-Compatible (2-wire) Serial EEPROM
1-Kbit (128 x 8), 2-Kbit (256 x 8)

DATASHEET

Features

- Low-voltage Operation
 - $V_{CC} = 1.7V$ to 5.5V
- Internally Organized as 128 x 8 (1K) or 256 x 8 (2K)
- I²C Compatible (2-wire) Serial Interface
- Schmitt Trigger, Filtered Inputs for Noise Suppression
- Bidirectional Data Transfer Protocol
- 400kHz (1.7V) and 1MHz (2.5V, 2.7V, 5.0V) Compatibility
- Write Protect Pin for Hardware Data Protection
- 8-byte Page Write Mode
 - Partial Page Writes Allowed
- Self-timed Write Cycle (5ms max)
- High-reliability
 - Endurance: 1,000,000 Write Cycles
 - Data Retention: 100 Years
- Green Package Options (Pb/Halide-free/RoHS-compliant)
 - 8-lead PDIP, 8-lead JEDEC SOIC, 8-lead TSSOP, 8-pad UDFN, 5-lead SOT23, and 8-ball VFBGA
- Die Sale Options: Wafer Form and Tape and Reel Available

Description

The Atmel® AT24C01C/02C provides 1024/2048-bits of Serial Electrically Erasable and Programmable Read-Only Memory (EEPROM) organized as 128/256 words of eight bits each. Both devices include a cascading feature that allows up to eight devices to share a common 2-wire bus. These devices are optimized for use in many industrial and commercial applications where low power and low voltage operation are essential. The AT24C01C/02C are available in space saving 8-lead PDIP, 8-lead JEDEC SOIC, 8-lead TSSOP, 8-lead UDFN, 5-lead SOT23, and 8-ball VFBGA packages. In addition, the entire family operates from 1.7V to 5.5V V_{CC} .

1. Pin Configurations and Pinouts

Table 1-1. Pin Descriptions

Pin Number	Pin Symbol	Pin Name and Functional Description	Asserted State	Pin Type
1, 2, 3	$A_0 - A_2$	Address Inputs: The A_2 , A_1 , and A_0 pins are device address inputs that are hard wired. As many as eight 1-Kbit or 2-Kbit devices may be addressed on a single bus system.	—	Input
4	GND	Ground: The ground reference for the power supply. GND should be connected to the system ground.	—	Power
5	SDA	Serial Data: The SDA pin is bidirectional for serial data transfer. This pin is open drain driven and may be wire-ORed with any number of other open drain or open collector devices.	—	Input/Output
6	SCL	Serial Clock Input: The SCL input is used to positive edge clock data into each EEPROM device and negative edge clock data out of each device.	—	Input
7	WP	Write Protect: Provides hardware data protection. The Write Protect pin allows normal read/write operations when connected to Ground (GND). When the Write Protect pin is connected to V_{CC} , the write protection feature is enabled and operates as shown in Table 5-1 .	—	Input
8	V_{CC}	Device Power Supply: The V_{CC} pin is used to supply the source voltage to the device. Operations at invalid V_{CC} voltages may produce spurious results and should not be attempted.	—	Power

Note: 1. For use of 5-lead SOT23, the software A2, A1, and A0 bits in the device address word must be set to zero to properly communicate.

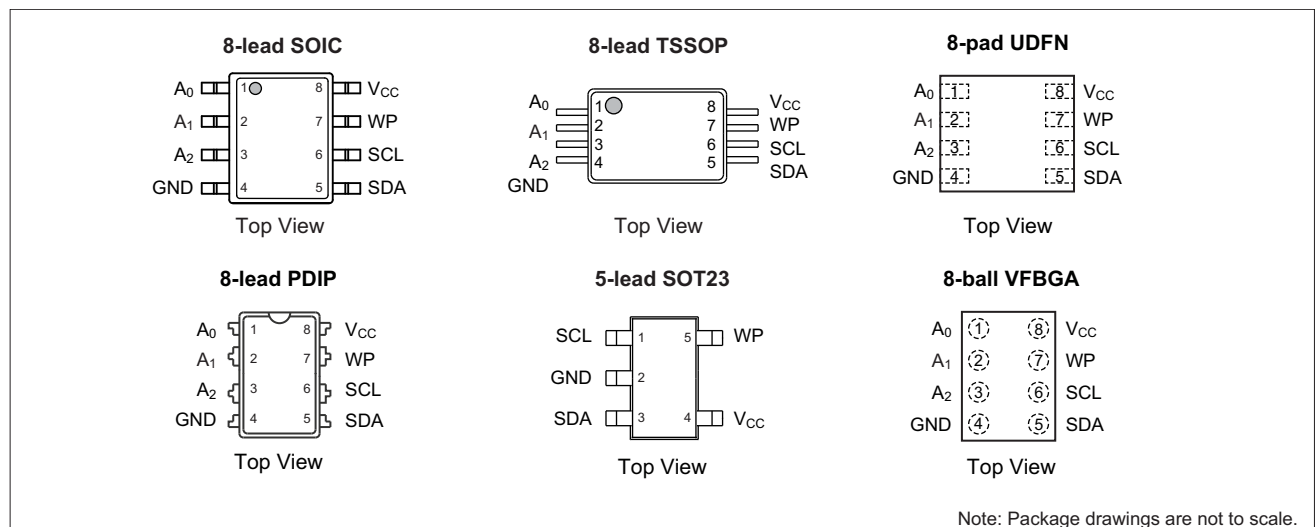

2. Block Diagram

Figure 2-1. Block Diagram

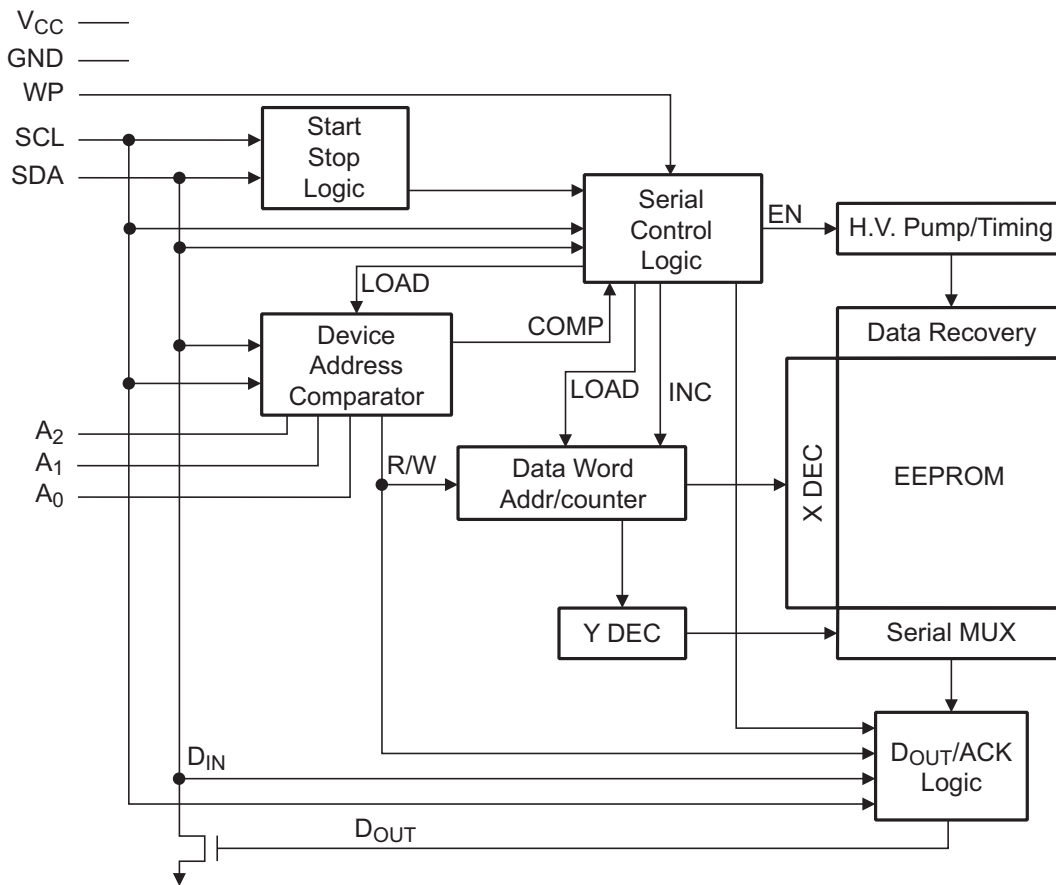

3. Absolute Maximum Ratings

Operating Temperature	-55°C to +125°C
Storage Temperature	-65°C to +150°C
Voltage on any pin with respect to ground	-1.0V to +7.0V
Maximum Operating Voltage	6.25V
DC Output Current	5.0mA

*Notice: Stresses beyond those listed under “Absolute Maximum Ratings” may cause permanent damage to the device. This is a stress rating only and functional operation of the device at these or any other conditions beyond those indicated in the operational sections of this specification is not implied. Exposure to absolute maximum rating conditions for extended periods may affect device reliability.

4. Memory Organization

AT24C01C, 1K Serial EEPROM: Internally organized with 16 pages of eight bytes each, the 1K requires a 7-bit data word address for random word addressing.

AT24C02C, 2K Serial EEPROM: Internally organized with 32 pages of eight bytes each, the 2K requires an 8-bit data word address for random word addressing.

4.1 Pin Capacitance

Table 4-1. Pin Capacitance⁽¹⁾

Applicable over recommended operating range from $T_A = 25^\circ\text{C}$, $f = 1.0\text{MHz}$, $V_{CC} = 1.7\text{V}$ to 5.5V .

Symbol	Test Condition	Max	Units	Conditions
$C_{I/O}$	Input/Output Capacitance (SDA)	8	pF	$V_{I/O} = 0\text{V}$
C_{IN}	Input Capacitance ($A_0, A_1, A_2, \text{SCL}$)	6	pF	$V_{IN} = 0\text{V}$

Note: 1. This parameter is characterized and is not 100% tested.

4.2 DC Characteristics

Table 4-2. DC Characteristics

Applicable over recommended operating range from: $T_A = -40^\circ\text{C}$ to $+85^\circ\text{C}$, $V_{CC} = 1.7\text{V}$ to 5.5V (unless otherwise noted).

Symbol	Parameter	Test Condition	Min	Typ	Max	Units
V_{CC1}	Supply Voltage		1.7		5.5	V
V_{CC2}	Supply Voltage		2.5		5.5	V
V_{CC3}	Supply Voltage		4.5		5.5	V
I_{CC1}	Supply Current $V_{CC} = 5.0\text{V}$	Read at 400kHz		0.4	1.0	mA
I_{CC2}	Supply Current $V_{CC} = 5.0\text{V}$	Write at 400kHz		2.0	3.0	mA
I_{SB1}	Standby Current $V_{CC} = 1.7\text{V}$	$V_{IN} = V_{CC}$ or V_{SS}			1.0	μA
I_{SB2}	Standby Current $V_{CC} = 2.5\text{V}$	$V_{IN} = V_{CC}$ or V_{SS}			2.0	μA
I_{SB3}	Standby Current $V_{CC} = 5.5\text{V}$	$V_{IN} = V_{CC}$ or V_{SS}			6.0	μA
I_{LI}	Input Leakage Current	$V_{IN} = V_{CC}$ or V_{SS}		0.10	3.0	μA
I_{LO}	Output Leakage Current	$V_{OUT} = V_{CC}$ or V_{SS}		0.05	3.0	μA
V_{IL}	Input Low Level ⁽¹⁾		-0.6		$V_{CC} \times 0.3$	V
V_{IH}	Input High Level ⁽¹⁾		$V_{CC} \times 0.7$		$V_{CC} + 0.5$	V
V_{OL1}	Output Low Level $V_{CC} = 1.7\text{V}$	$I_{OL} = 0.15\text{mA}$			0.2	V
V_{OL2}	Output Low Level $V_{CC} = 3.0\text{V}$	$I_{OL} = 2.1\text{mA}$			0.4	V

Note: 1. V_{IL} min and V_{IH} max are reference only and are not tested.

4.3 AC Characteristics

Table 4-3. AC Characteristics

Applicable over recommended operating range from $T_{AI} = -40^{\circ}\text{C}$ to $+85^{\circ}\text{C}$, $V_{CC} = 1.7\text{V}$ to 5.5V , $CL = 1\text{TTL Gate and } 100\text{pF}$ (unless otherwise noted). Test conditions are listed in [Note 2](#).

Symbol	Parameter	1.7V		2.5V, 5.0V		Units
		Min	Max	Min	Max	
f_{SCL}	Clock Frequency, SCL		400		1000	kHz
t_{LOW}	Clock Pulse Width Low	1.2		0.4		μs
t_{HIGH}	Clock Pulse Width High	0.6		0.4		μs
t_I	Noise Suppression Time		100		50	ns
t_{AA}	Clock Low to Data Out Valid	0.1	0.9	0.05	0.55	μs
t_{BUF}	Time the bus must be free before a new transmission can start.	1.2		0.5		μs
$t_{HD.STA}$	Start Hold Time	0.6		0.25		μs
$t_{SU.STA}$	Start Setup Time	0.6		0.25		μs
$t_{HD.DAT}$	Data In Hold Time	0		0		μs
$t_{SU.DAT}$	Data In Setup Time	100		100		ns
t_R	Inputs Rise Time ⁽¹⁾		0.3		0.3	μs
t_F	Inputs Fall Time ⁽¹⁾		300		100	ns
$t_{SU.STO}$	Stop Setup Time	0.6		.25		μs
t_{DH}	Data Out Hold Time	50		50		ns
t_{WR}	Write Cycle Time		5		5	ms
Endurance ⁽¹⁾	3.3V, +25°C, Page Mode	1,000,000				Write Cycles

- Note:
1. This parameter is ensured by characterization only.
 2. AC measurement conditions:
 - R_L (connects to V_{CC}): 1.3 k Ω (2.5V, 5V), 10 k Ω (1.7V)
 - Input pulse voltages: 0.3 V_{CC} to 0.7 V_{CC}
 - Input rise and fall times: $\leq 50\text{ns}$
 - Input and output timing reference voltages: 0.5 V_{CC}

5. Write Protection

The AT24C01C/02C utilizes a hardware data protection scheme that allows the user to write protect the entire memory contents when the WP pin is at V_{CC} (or a valid V_{IH}). No write protection will be set if the WP pin is at GND or left floating.

Table 5-1. Write Protect

WP Pin Status	Part of the Array Protected
At V_{CC}	Full (2K) Array
At GND	Normal Read/Write Operations

6. Device Operation

Clock and Data Transitions: The SDA pin is normally pulled high with an external device. Data on the SDA pin may change only during SCL low time periods. Data changes during SCL high periods will indicate a Start or Stop condition as defined below.

Figure 6-1. Data Validity

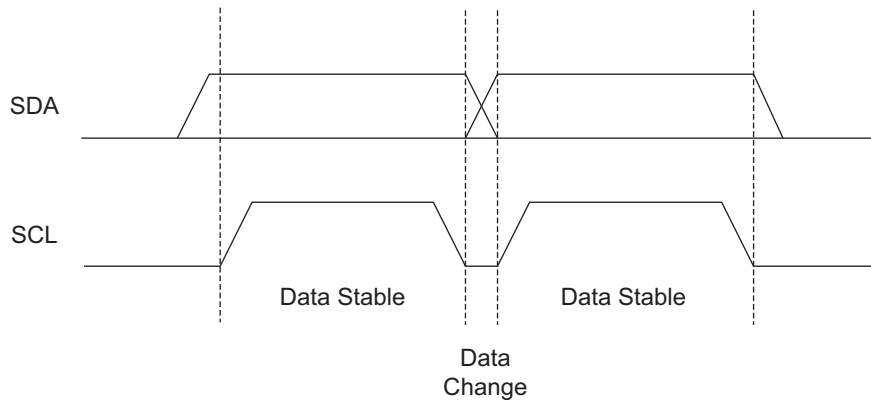

Start Condition: A high-to-low transition of SDA with SCL high is a Start condition which must precede any other command.

Stop Condition: A low-to-high transition of SDA with SCL high is a Stop condition. After a read sequence, the Stop condition will place the EEPROM in a standby power mode.

Figure 6-2. Start and Stop Definition

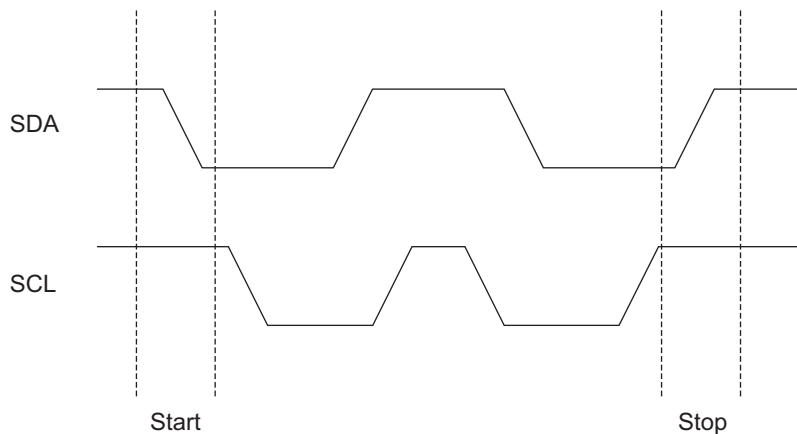

Acknowledge: All addresses and data words are serially transmitted to and from the EEPROM in 8-bit words. The EEPROM sends a zero to acknowledge that it has received each word. This happens during the ninth clock cycle.

Figure 6-3. Output Acknowledge

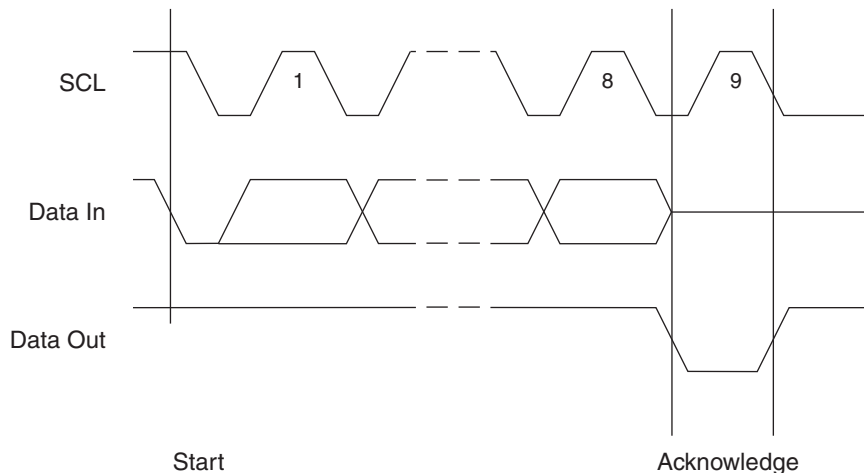

Standby Mode: The AT24C01C/02C features a low-power standby mode which is enabled:

- Upon power-up.
- After the receipt of the Stop condition and the completion of any internal operations.

2-wire Software Reset: After an interruption in protocol, power-loss, or system reset, any 2-wire part can be reset by following these steps:

1. Create a Start condition (if possible).
2. Clock nine cycles.
3. Create another Start condition followed by Stop condition as shown in [Figure 6-4](#).

The device will be ready for the next communication after above steps have been completed. The device should be ready for the next communication after above steps have been completed. In the event that the device is still non-responsive or remains active on the SDA bus, a power cycle must be used to reset the device.

Figure 6-4. Software Reset

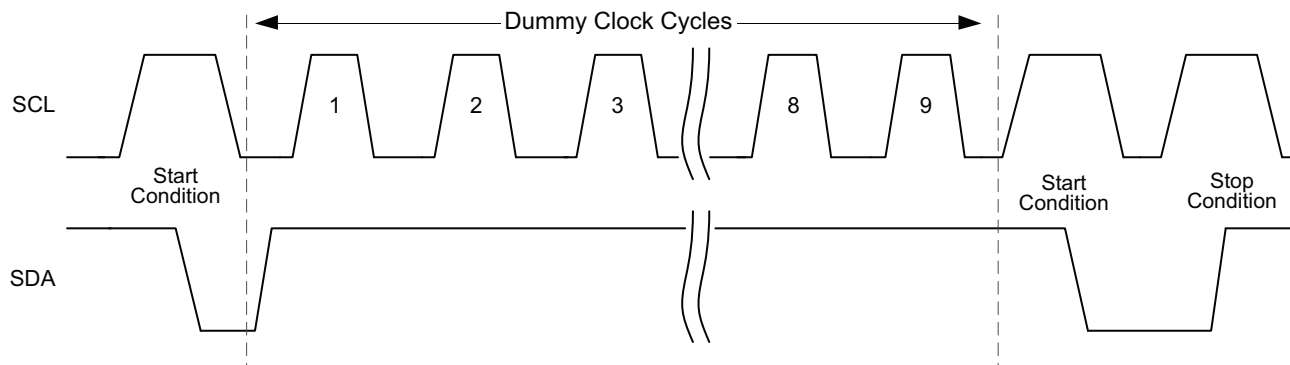

Figure 6-5. Bus Timing

SCL: Serial Clock, SDA: Serial Data I/O

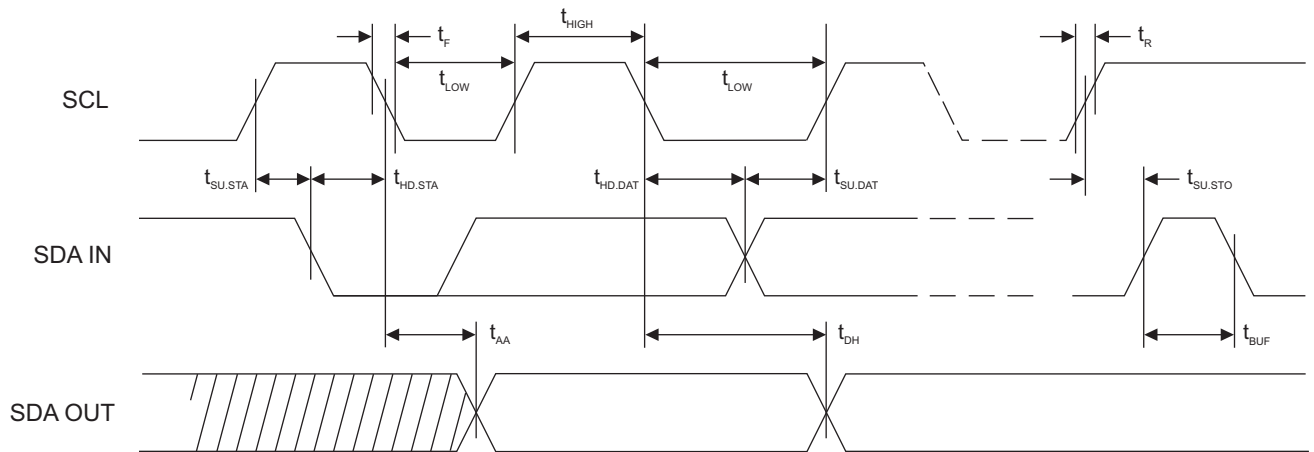
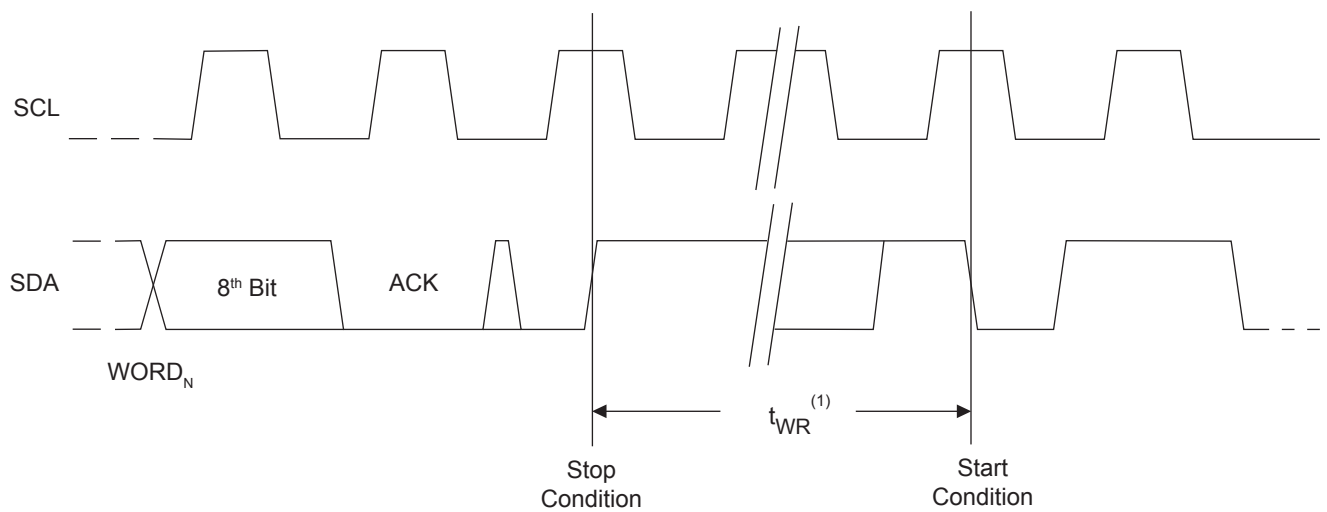

Figure 6-6. Write Cycle Timing

SCL: Serial Clock, SDA: Serial Data I/O



Note: 1. The write cycle time t_{WR} is the time from a valid Stop condition of a write sequence to the end of the internal clear/write cycle.

7. Device Addressing

The 1-Kbit and 2-Kbit EEPROM device requires an 8-bit device address word following a Start condition to enable the device for a Read or Write operation.

The device address word consists of a mandatory '1010' (0xA) sequence for the first four most significant bits as shown in Figure 7-1. This is common to all Serial EEPROM devices.

The next three bits are the A₂, A₁, and A₀ device address bits for the 1K and 2K EEPROM. These three bits must compare to their corresponding hard-wired input pins A₂, A₁, and A₀ in order for the part to acknowledge.

The eighth bit of the device address is the Read/Write operation select bit. A Read operation is initiated if this bit is high and a Write operation is initiated if this bit is low.

Upon a valid compare of the device address with hard-wired input pins A₂, A₁, and A₀, the EEPROM will output a zero. If a compare is not successfully made, the chip will return to a standby state.

Figure 7-1. Device Address

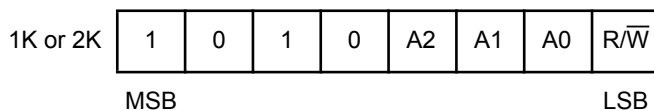

8. Write Operations

Byte Write: A Byte Write operation requires an 8-bit data word address following the device address word and acknowledgment. Upon receipt of this address, the EEPROM will again respond with a zero and then clock in the first 8-bit data word. Following receipt of the 8-bit data word, the EEPROM will output a zero and the addressing device, such as a microcontroller, must terminate the write sequence with a Stop condition. At this time, the EEPROM enters an internally timed write cycle, t_{WR} , to the nonvolatile memory. All inputs are disabled during this write cycle and the EEPROM will not respond until the write is complete.

Figure 8-1. Byte Write

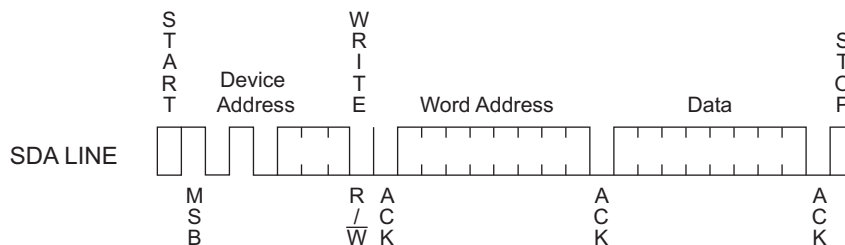

Page Write: The 1-Kbit and 2-Kbit EEPROM are capable of an 8-byte Page Write.

A Page Write is initiated the same as a Byte Write, but the microcontroller does not send a Stop condition after the first data word is clocked in. Instead, after the EEPROM acknowledges receipt of the first data word, the microcontroller can transmit up to seven data words. The EEPROM will respond with a zero after each data word received. The microcontroller must terminate the page write sequence with a Stop condition.

The data word address lower three bits are internally incremented following the receipt of each data word. The higher data word address bits are not incremented, retaining the memory page row location. When the word address, internally generated, reaches the page boundary, the following byte is placed at the beginning of the same page. If more than eight data words are transmitted to the EEPROM, the data word address will “roll over” and previous data will be overwritten.

Figure 8-2. Page Write

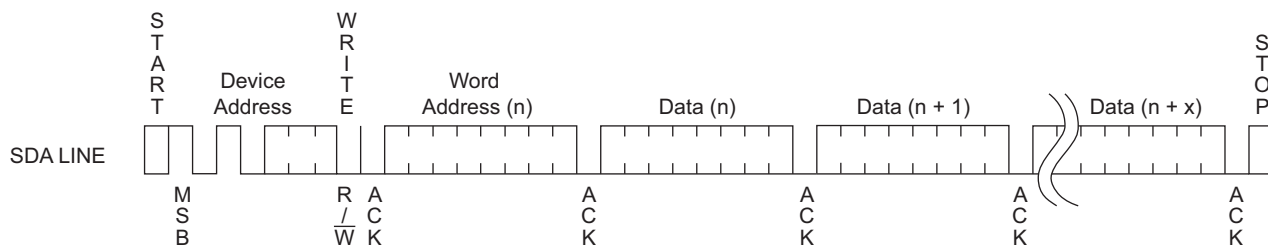

Acknowledge Polling: Once the internally timed write cycle has started and the EEPROM inputs are disabled, acknowledge polling can be initiated. This involves sending a Start condition followed by the device address word. The read/write bit is representative of the operation desired. Only if the internal write cycle has completed will the EEPROM respond with a zero allowing the read or write sequence to continue.

Data Security: The AT24C01C/02C has a hardware data protection scheme that allows the user to write protect the entire memory when the WP pin is at V_{CC} .

9. Read Operations

Read operations are initiated the same way as write operations with the exception that the read/write select bit in the device address word is set to one. There are three read operations:

- Current Address Read
- Random Address Read
- Sequential Read.

Current Address Read: The internal data word address counter maintains the last address accessed during the last read or write operation, incremented by one. This address stays valid between operations as long as the chip power is maintained. The address roll-over during read is from the last byte of the last memory page to the first byte of the first page. The address roll-over during write is from the last byte of the current page to the first byte of the same page.

Once the device address with the read/write select bit set to one is clocked in and acknowledged by the EEPROM, the current address data word is serially clocked out. The microcontroller does not respond with a zero but does generate a following Stop condition

Figure 9-1. Current Address Read

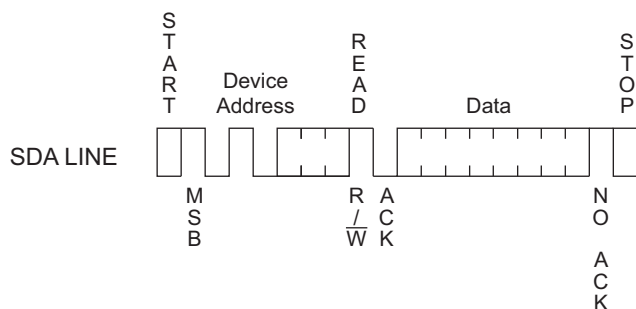

Random Read: A Random Read requires a dummy byte write sequence to load in the data word address. Once the device address word and data word address are clocked in and acknowledged by the EEPROM, the microcontroller must generate another start condition. The microcontroller now initiates a Current Address Read by sending a device address with the read/write select bit high. The EEPROM acknowledges the device address and serially clocks out the data word. The microcontroller does not respond with a zero but does generate a following stop condition.

Figure 9-2. Random Read

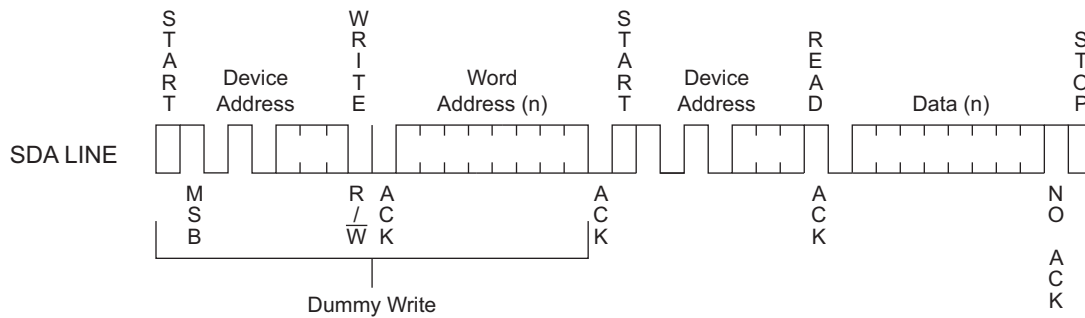

Sequential Read: Sequential Reads are initiated by either a Current Address Read or a Random Address Read. After the microcontroller receives a data word, it responds with an acknowledge. As long as the EEPROM receives an acknowledge, it will continue to increment the data word address and serially clock out sequential data words. When the memory address limit is reached, the data word address will roll-over and the Sequential Read will continue. The Sequential Read operation is terminated when the microcontroller does not respond with a zero but does generate a following stop condition.

Figure 9-3. Sequential Read

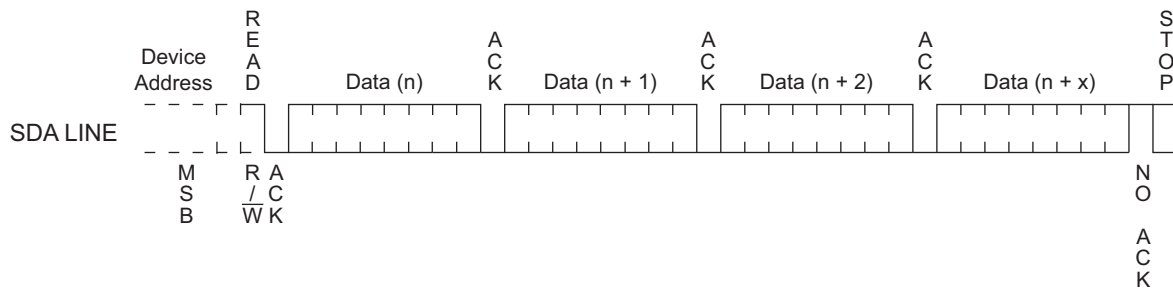

10. Ordering Code Detail

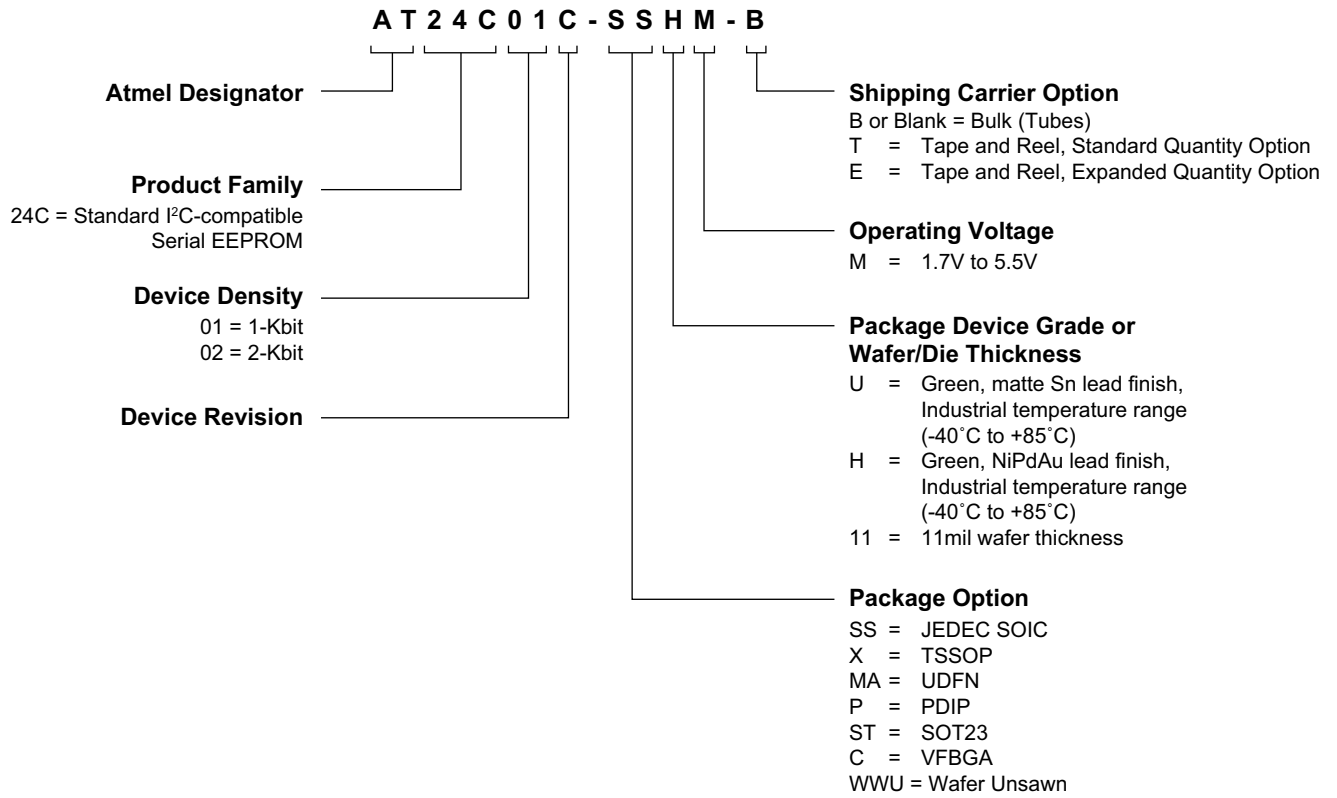

11. Part Markings

AT24C01C and AT24C02C: Package Marking Information

8-lead PDIP	8-lead SOIC	8-lead TSSOP
8-pad UDFN	5-lead SOT-23	8-ball VFBGA
2.0 x 3.0 mm Body 		2.35 x 3.73 mm Body

Note 1: ● designates pin 1

Note 2: Package drawings are not to scale

Note 3: For SOT23 package with date codes before 7B, the bottom line (YMXX) is marked on the bottom side and there is no Country of Assembly (@) mark on the top line.

Catalog Number Truncation			
AT24C01C		Truncation Code ###: 01C / ##: 1C	
AT24C02C		Truncation Code ###: 02C / ##: 2C	
Date Codes			Voltages
Y = Year	M = Month	WW = Work Week of Assembly	% = Minimum Voltage
6: 2016 0: 2020	A: January	02: Week 2	M: 1.7V min
7: 2017 1: 2021	B: February	04: Week 4	
8: 2018 2: 2022	
9: 2019 3: 2023	L: December	52: Week 52	
Country of Assembly		Lot Number	Grade/Lead Finish Material
@ = Country of Assembly		AAA...A = Atmel Wafer Lot Number	U: Industrial/Matte Tin/SnAgCu H: Industrial/NiPdAu
Trace Code			Atmel Truncation
XX = Trace Code (Atmel Lot Numbers Correspond to Code) Example: AA, AB.... YZ, ZZ			AT: Atmel ATM: Atmel ATML: Atmel

12/7/16

 Package Mark Contact: DL-CSO-Assy_eng@atmel.com	TITLE	DRAWING NO.	REV.
	24C01-02CSM , AT24C01C and AT24C02C Package Marking Information	24C01-02CSM	C

12. Ordering Information

Atmel Ordering Code	Lead Finish	Package	Delivery Information		Operation Range	
			Form	Quantity		
AT24C01C-SSHM-B	NiPdAu (Lead-free/Halogen-free)	8S1	Bulk (Tubes)	100 per Tube	Industrial Temperature (-40°C to 85°C)	
AT24C01C-SSHM-T			Tape and Reel	4,000 per Reel		
AT24C01C-XHM-B		8X	Bulk (Tubes)	100 per Tube		
AT24C01C-XHM-T			Tape and Reel	5,000 per Reel		
AT24C01C-MAHM-T		8MA2	Tape and Reel	5,000 per Reel		
AT24C01C-MAHM-E			Tape and Reel	15,000 per Reel		
AT24C01C-PUM		Matte Tin (Lead-free/Halogen-free)	8P3	Bulk (Tubes)		50 per Tube
AT24C01C-STUM-T			5TS1	Tape and Reel		5,000 per Reel
AT24C01C-CUM-T		SnAgCu Ball (Lead-free/Halogen-free)	8U3-1	Tape and Reel		5,000 per Reel
AT24C01C-WWU11M ⁽¹⁾		N/A	Wafer Sale	Note 1		
AT24C02C-SSHM-B	NiPdAu (Lead-free/Halogen-free)	8S1	Bulk (Tubes)	100 per Tube	Industrial Temperature (-40°C to 85°C)	
AT24C02C-SSHM-T			Tape and Reel	4,000 per Reel		
AT24C02C-XHM-B		8X	Bulk (Tubes)	100 per Tube		
AT24C02C-XHM-T			Tape and Reel	5,000 per Reel		
AT24C02C-MAHM-T		8MA2	Tape and Reel	5,000 per Reel		
AT24C02C-MAHM-E			Tape and Reel	15,000 per Reel		
AT24C02C-PUM		Matte Tin (Lead-free/Halogen-free)	8P3	Bulk (Tubes)		50 per Tube
AT24C02C-STUM-T			5TS1	Tape and Reel		5,000 per Reel
AT24C02C-CUM-T		SnAgCu Ball (Lead-free/Halogen-free)	8U3-1	Tape and Reel		5,000 per Reel
AT24C02C-WWU11M ⁽¹⁾		N/A	Wafer Sale	Note 1		

Note: 1. For Wafer sales, please contact Atmel Sales.

Package Type	
8P3	8-lead, 0.300" wide, Plastic Dual Inline (PDIP)
8S1	8-lead, 0.150" wide, Plastic Gull Wing Small Outline (JEDEC SOIC)
8X	8-lead, 4.4mm body, Plastic Thin Shrink Small Outline (TSSOP)
8MA2	8-lead, 2.00mm x 3.00mm body, 0.50mm Pitch, Ultra Thin Dual Flat No Lead (UDFN)
5TS1	5-lead, 2.90mm x 1.60mm body, Plastic Thin Shrink Small Outline (SOT23)
8U3-1	8-ball, die Ball Grid Array (VFBGA)

13. Packaging Information

13.1 8S1 — 8-lead JEDEC SOIC

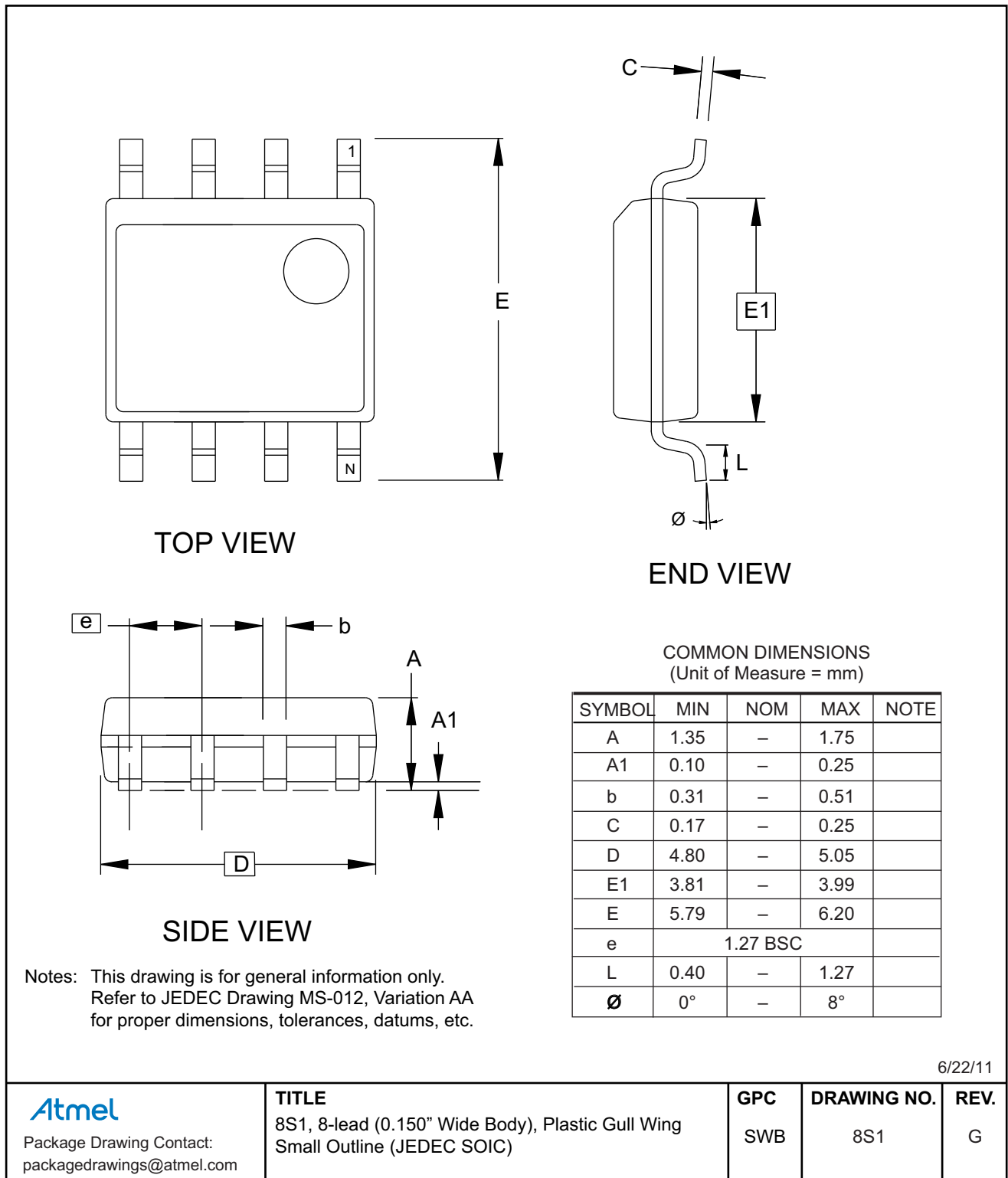

13.2 8X — 8-lead TSSOP

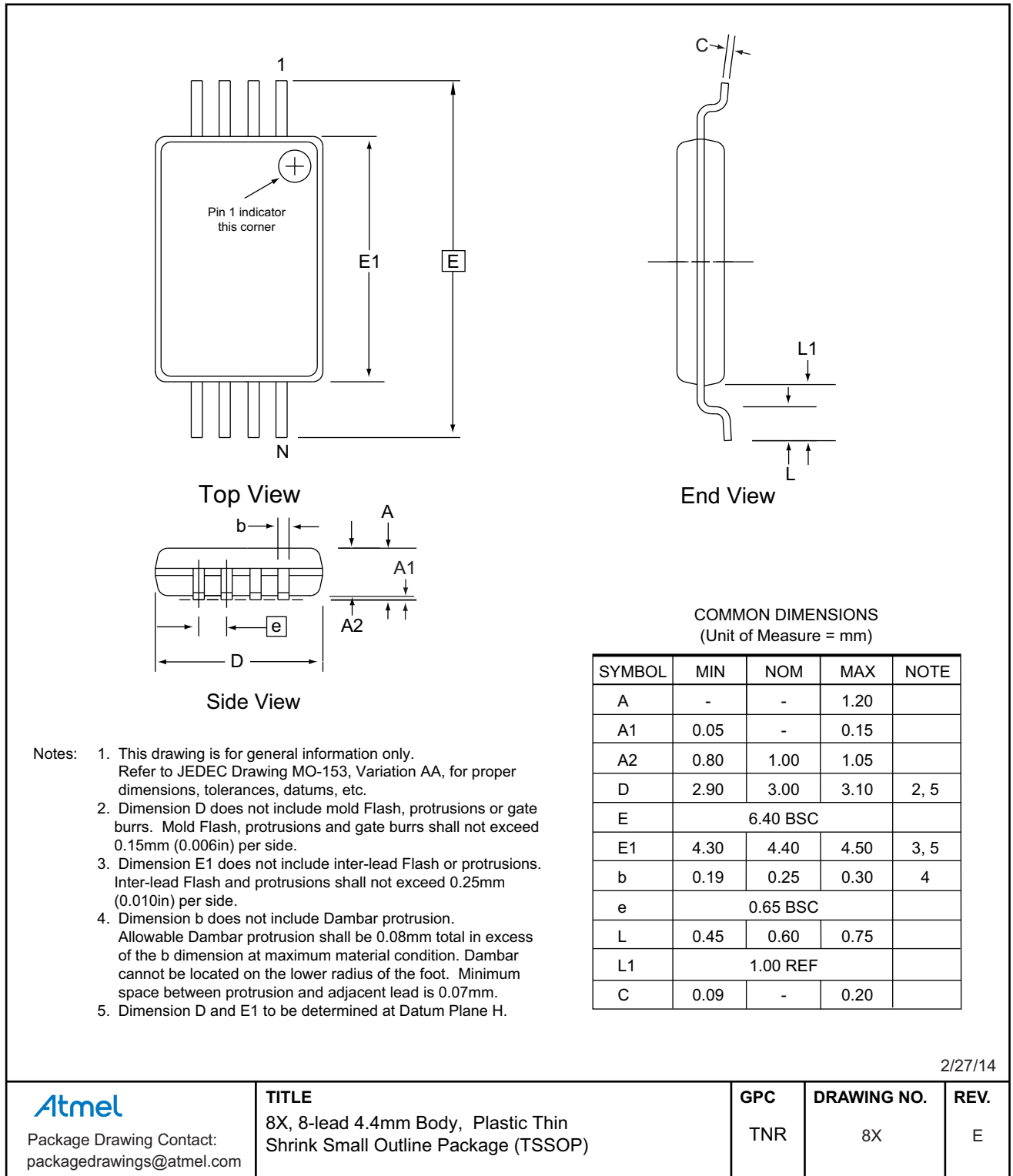

13.3 8MA2 — 8-pad UDFN

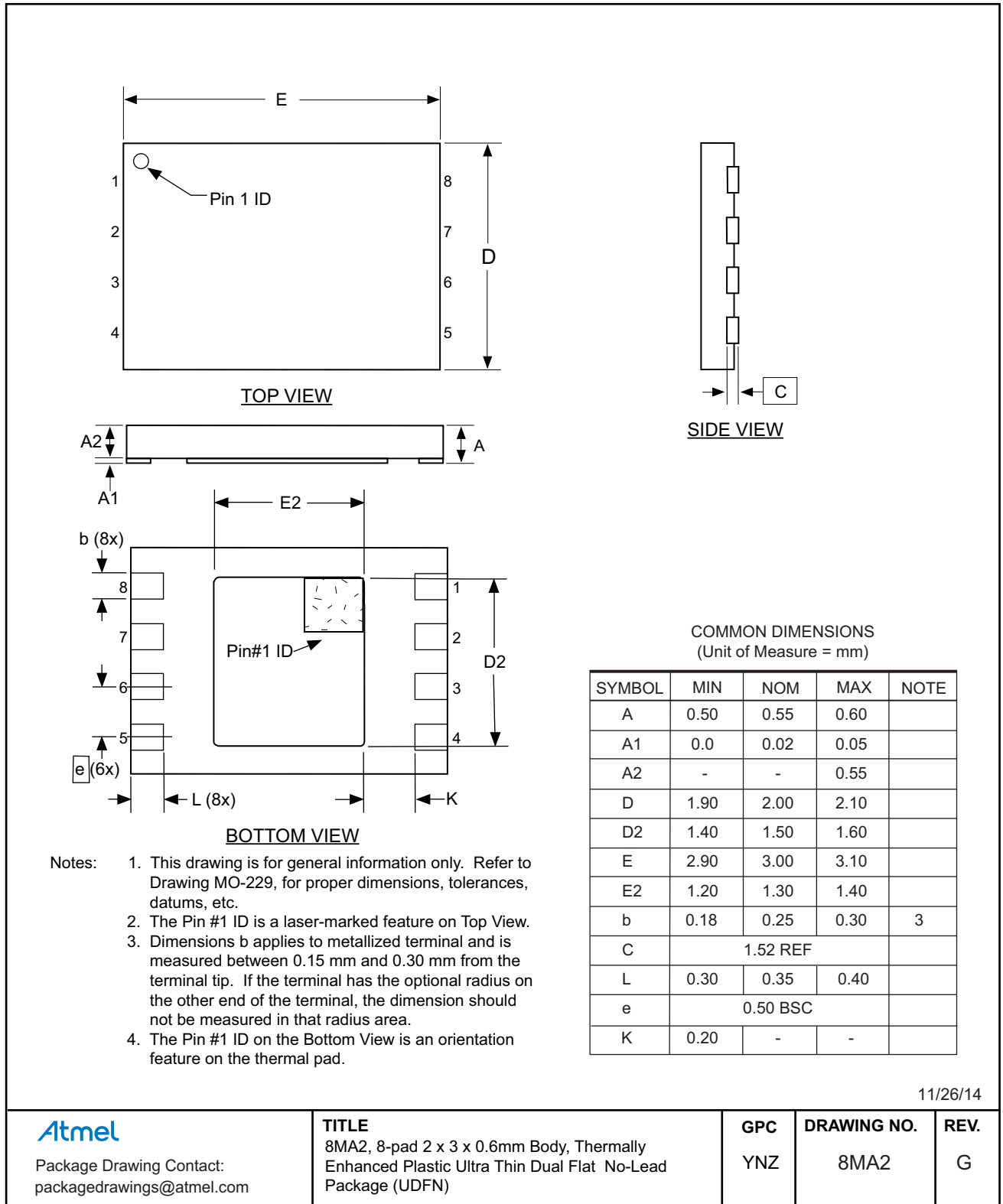

11/26/14

Atmel

Package Drawing Contact:
packagedrawings@atmel.com

TITLE

8MA2, 8-pad 2 x 3 x 0.6mm Body, Thermally Enhanced Plastic Ultra Thin Dual Flat No-Lead Package (UDFN)

GPC

YNZ

DRAWING NO.

8MA2

REV.

G

13.4 8P3 — 8-lead PDIP

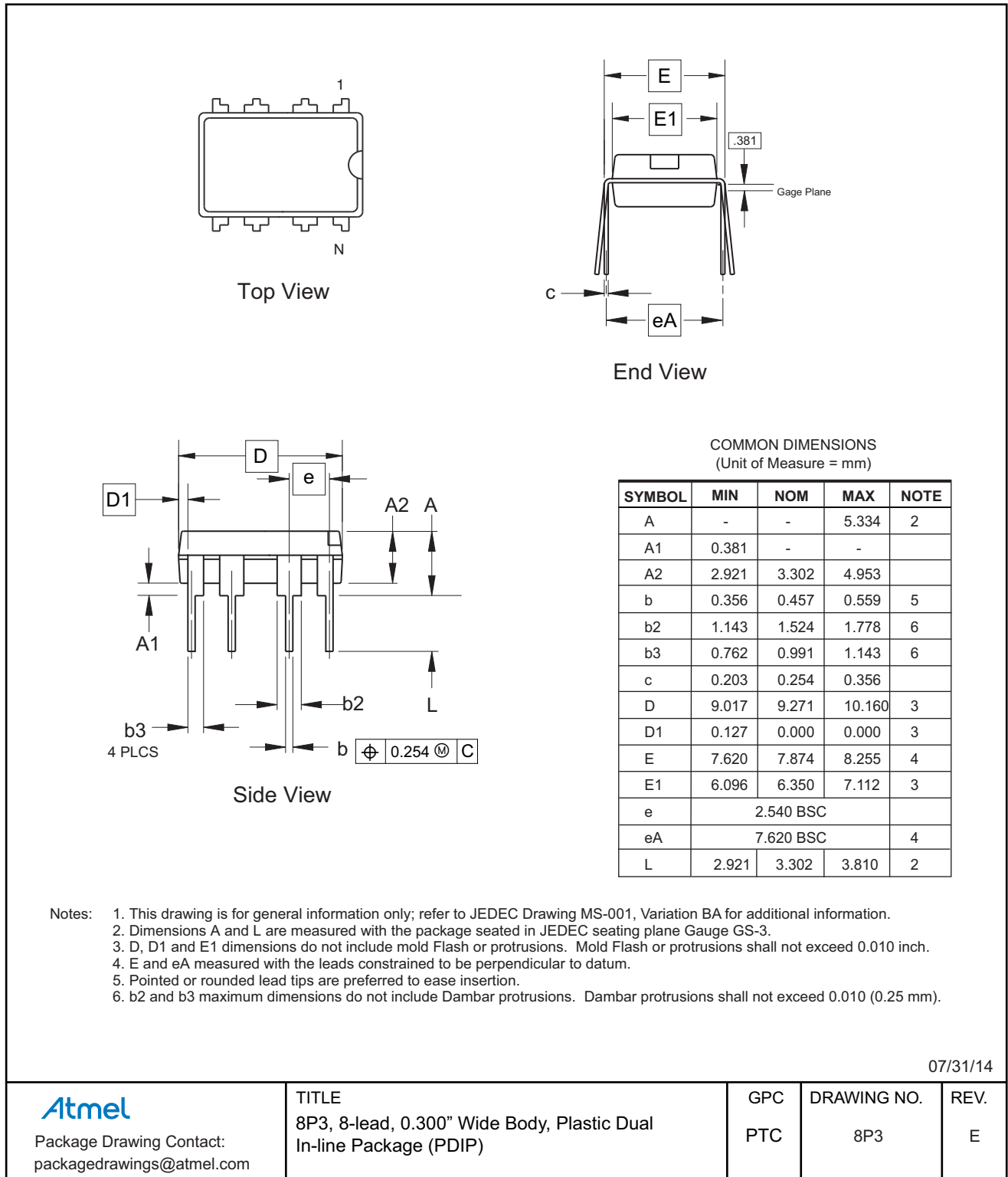

13.5 5TS1 — 5-lead SOT23

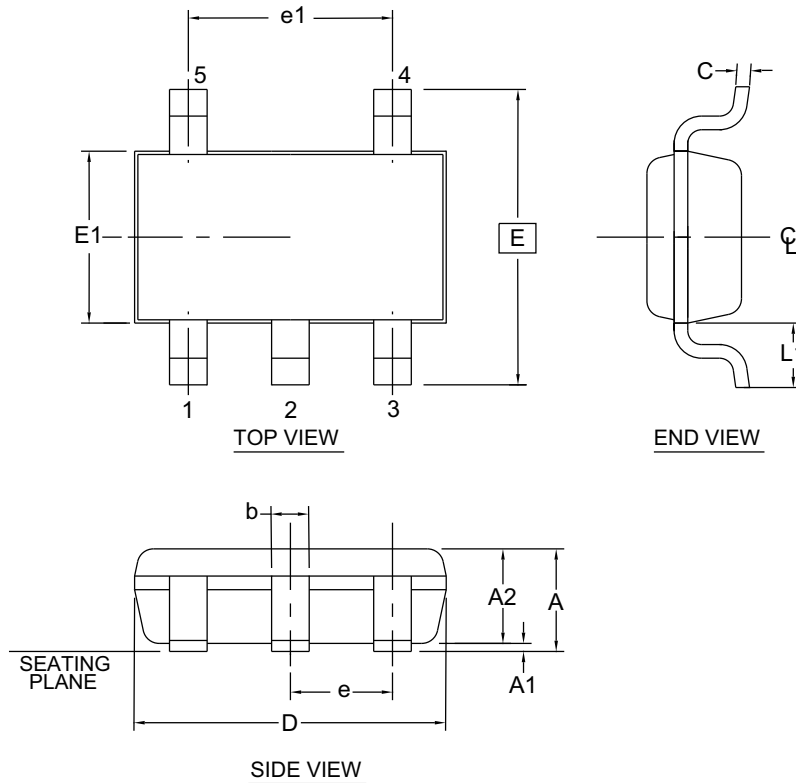

1. Dimension D does not include mold flash, protrusions or gate burrs. Mold flash, protrusions or gate burrs shall not exceed 0.15 mm per end. Dimension E1 does not include interlead flash or protrusion. Interlead flash or protrusion shall not exceed 0.15 mm per side.
2. The package top may be smaller than the package bottom. Dimensions D and E1 are determined at the outermost extremes of the plastic body exclusive of mold flash, tie bar burrs, gate burrs and interlead flash, but including any mismatch between the top and bottom of the plastic body.
3. These dimensions apply to the flat section of the lead between 0.08 mm and 0.15 mm from the lead tip.
4. Dimension "b" does not include dambar protrusion. Allowable dambar protrusion shall be 0.08 mm total in excess of the "b" dimension at maximum material condition. The dambar cannot be located on the lower radius of the foot. Minimum space between protrusion and an adjacent lead shall not be less than 0.07 mm.

This drawing is for general information only. Refer to JEDEC Drawing MO-193, Variation AB for additional information.

COMMON DIMENSIONS
(Unit of Measure = mm)

SYMBOL	MIN	NOM	MAX	NOTE
A	-	-	1.00	
A1	0.00	-	0.10	
A2	0.70	0.90	1.00	
c	0.08	-	0.20	3
D	2.90 BSC			1,2
E	2.80 BSC			1,2
E1	1.60 BSC			1,2
L1	0.60 REF			
e	0.95 BSC			
e1	1.90 BSC			
b	0.30	-	0.50	3,4

5/31/12

 Package Drawing Contact: packagedrawings@atmel.com	TITLE	GPC	DRAWING NO.	REV.
	5TS1, 5-lead 1.60mm Body, Plastic Thin Shrink Small Outline Package (Shrink SOT)	TSZ	5TS1	D

13.6 8U3-1 — 8-ball VFBGA

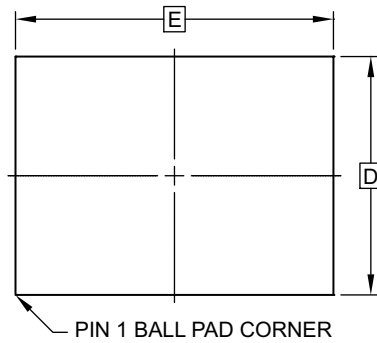

TOP VIEW

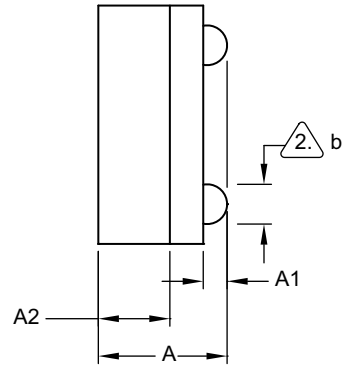

SIDE VIEW

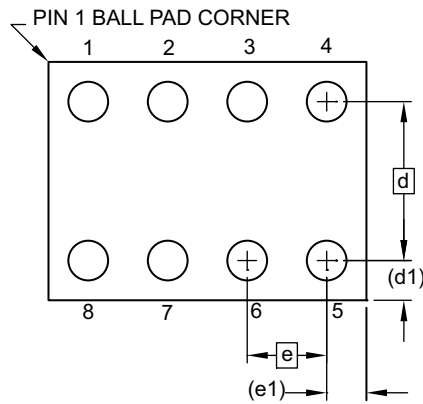

BOTTOM VIEW
8 SOLDER BALLS

Notes:

1. This drawing is for general information only.
2. Dimension 'b' is measured at maximum solder ball diameter.
3. Solder ball composition shall be 95.5Sn-4.0Ag-.5Cu.

COMMON DIMENSIONS
(Unit of Measure - mm)

SYMBOL	MIN	NOM	MAX	NOTE
A	0.73	0.79	0.85	
A1	0.09	0.14	0.19	
A2	0.40	0.45	0.50	
b	0.20	0.25	0.30	2
D	1.50 BSC			
E	2.0 BSC			
e	0.50 BSC			
e1	0.25 REF			
d	1.00 BSC			
d1	0.25 REF			

6/11/13

<p>Package Drawing Contact: packagedrawings@atmel.com</p>	<p>TITLE 8U3-1, 8-ball, 1.50mm x 2.00mm body, 0.50mm pitch, Very Thin, Fine-Pitch Ball Grid Array Package (VFBGA)</p>	GPC	DRAWING NO.	REV.
		GXU	8U3-1	F

14. Revision History

Doc. Rev.	Date	Comments
8700H	12/2016	Part marking SOT23: - Moved backside mark (YMXX) to front side line2. - Added @ = Country of Assembly.
8700G	01/2015	Add the UDFN extended quantity option. Update part markings, package drawings, ordering information, template, and reorganize.
8700F	06/2012	Correct ordering codes: - AT24C01C-WWU11, Die Sale to AT24C01C-WWU11M, Wafer Sale. - AT24C02C-WWU11, Die Sale to AT24C02C-WWU11M, Wafer Sale. Remove WDT from ordering code detail. Update Atmel logos and disclaimer page.
8700E	05/2012	Update datasheet template. Add AT24C01C to document. Electrical performance improvements: - Reduce all ISB from legacy values - Increase 1MHz frequency range to include 2.5V operation. Update package drawings to latest versions (where applicable) and selected waveforms.
8700D	08/2010	Change AT24C02C-XHM Part Marking from C02CM@ to 02CM @.
8700C	07/2010	Ordering Information: - Change Atmel AT24C02C-TSUM-T to Atmel AT24C02C-STUM-T. - Change Atmel AT24C02CY6-MAHM-T to Atmel AT24C02C-MAHM-T. - Change Atmel AT24C02CU3-CUM-T to Atmel AT24C02C-CUM-T. Catalog numbering scheme, change TS = SOT23 to ST = SOT23. Part marking SOT23: - Change 2CMWU to 2CMBU. - Change W = Write Protection Feature to B = Write Protection. Part marking PDIP and SOIC: Added @ = Country of Assembly. Part marking TSSOP: Replaced and removed bottom mark. Part marking UDFN: Added HM@. Remove preliminary status. Change t_1 Max 40 to 50 in Table AC Characteristics.
8700B	02/2010	Correct catalog numbering scheme and ordering information.
8700A	12/2009	Initial document release.



Atmel®, Atmel logo and combinations thereof, Enabling Unlimited Possibilities®, and others are registered trademarks or trademarks of Atmel Corporation in U.S. and other countries. Other terms and product names may be trademarks of others.

DISCLAIMER: The information in this document is provided in connection with Atmel products. No license, express or implied, by estoppel or otherwise, to any intellectual property right is granted by this document or in connection with the sale of Atmel products. EXCEPT AS SET FORTH IN THE ATMEL TERMS AND CONDITIONS OF SALES LOCATED ON THE ATMEL WEBSITE, ATMEL ASSUMES NO LIABILITY WHATSOEVER AND DISCLAIMS ANY EXPRESS, IMPLIED OR STATUTORY WARRANTY RELATING TO ITS PRODUCTS INCLUDING, BUT NOT LIMITED TO, THE IMPLIED WARRANTY OF MERCHANTABILITY, FITNESS FOR A PARTICULAR PURPOSE, OR NON-INFRINGEMENT. IN NO EVENT SHALL ATMEL BE LIABLE FOR ANY DIRECT, INDIRECT, CONSEQUENTIAL, PUNITIVE, SPECIAL OR INCIDENTAL DAMAGES (INCLUDING, WITHOUT LIMITATION, DAMAGES FOR LOSS AND PROFITS, BUSINESS INTERRUPTION, OR LOSS OF INFORMATION) ARISING OUT OF THE USE OR INABILITY TO USE THIS DOCUMENT, EVEN IF ATMEL HAS BEEN ADVISED OF THE POSSIBILITY OF SUCH DAMAGES. Atmel makes no representations or warranties with respect to the accuracy or completeness of the contents of this document and reserves the right to make changes to specifications and products descriptions at any time without notice. Atmel does not make any commitment to update the information contained herein. Unless specifically provided otherwise, Atmel products are not suitable for, and shall not be used in, automotive applications. Atmel products are not intended, authorized, or warranted for use as components in applications intended to support or sustain life.

SAFETY-CRITICAL, MILITARY, AND AUTOMOTIVE APPLICATIONS DISCLAIMER: Atmel products are not designed for and will not be used in connection with any applications where the failure of such products would reasonably be expected to result in significant personal injury or death ("Safety-Critical Applications") without an Atmel officer's specific written consent. Safety-Critical Applications include, without limitation, life support devices and systems, equipment or systems for the operation of nuclear facilities and weapons systems. Atmel products are not designed nor intended for use in military or aerospace applications or environments unless specifically designated by Atmel as military-grade. Atmel products are not designed nor intended for use in automotive applications unless specifically designated by Atmel as automotive-grade.

X-ON Electronics

Largest Supplier of Electrical and Electronic Components

Click to view similar products for [EEPROM](#) category:

Click to view products by [Microchip](#) manufacturer:

Other Similar products are found below :

[M29F040-70K6](#) [718278CB](#) [718620G](#) [444358RB](#) [444362FB](#) [BR93C46-WMN7TP](#) [EEROMH](#) [CAT25320YIGT-KK](#) [LE24C162-R-E](#) [5962-8751409YA](#) [BR9016AF-WE2](#) [LE2464DXATBG](#) [CAS93C66VP2I-GT3](#) [W60002FT20T](#) [CAT24S128C4UTR](#) [ZD24C64B-SSGMA0](#) [BL24C04F-RRRC](#) [S-25C040A0I-I8T1U](#) [AT24C256BY7-YH-T](#) [M24C64-DFCT6TPK](#) [BR24C21FJ-E2](#) [BR24G02FVJ-3GTE2](#) [BR24L16FJ-WE2](#) [BR24L16FVJ-WE2](#) [BR24S16FJ-WE2](#) [BR24S256F-WE2](#) [BR93L56RFV-WE2](#) [BR93L66F-WE2](#) [BR93L76RFV-WE2](#) [CAT24C64C4CTR](#) [CHL24C32WEGT3](#) [AT28HC256E-12SU-T](#) [AT93C46DY6-YH-T](#) [BR24T02FVT-WSGE2](#) [M35B32-WMN6TP](#) [M24C64-FMC6TG](#) [M24C08-WDW6TP](#) [CAT25080VP2IGTQH](#) [CAT25020ZIGT-QP](#) [CAT24C01VP2I-GT3](#) [CAT93C76BZI-GT3](#) [CAT64LC40WI-T3](#) [CAT25256HU4E-GT3](#) [CAT25128VP2I-GT3](#) [CAT25040VP2I-GT3](#) [CAT25020VP2I-GT3](#) [CAT24C16ZI-G](#) [CAT24C05LI-G](#) [CAT24C01ZI-G](#) [CAT24C05WI-G](#)