I²C-Compatible (2-Wire) Serial EEPROM
4K (512 x 8)

DATASHEET

Features

- Write Protect Pin for Hardware Data Protection
 - Utilizes Different Array Protection Compared to the AT24C04B
- Low-voltage and Standard-voltage Operation
 - 1.8V ($V_{CC} = 1.8V$ to 5.5V)
- Internally Organized 512 x 8 (4K)
- 2-Wire Serial Interface
- Schmitt Trigger, Filtered Inputs for Noise Suppression
- Bidirectional Data Transfer Protocol
- 1MHz (5V) and 400kHz (1.8V, 2.5V, 2.7V) Clock Rate
- 16-byte Page
- Partial Page Writes Allowed
- Self-timed Write Cycle (5ms Max)
- High Reliability
 - Endurance: 1,000,000 Write Cycles
 - Data Retention: 100 Years
- 8-lead PDIP, 8-lead JEDEC SOIC, and 8-lead TSSOP Packages
- Die Sales: Wafer Form, Tape and Reel, and Bumped Wafers

Description

The Atmel® AT24HC04B provides 4,096 bits of Serial Electrically Erasable and Programmable Read-Only Memory (EEPROM) organized as 512 words of 8 bits each. The device is optimized for use in many industrial and commercial applications where low-power and low-voltage operation are essential. The AT24HC04B is available in space-saving 8-lead PDIP, 8-lead JEDEC SOIC, and 8-lead TSSOP packages and is accessed via a 2-wire serial interface. In addition, the entire family is available in 1.8V (1.8V to 5.5V) version.

1. Pin Configurations and Pinouts

Table 1-1. Pin Configuration

Pin Name	Function
NC	No Connect
A1 and A2	Address Inputs
SDA	Serial Data
SCL	Serial Clock Input
WP	Write Protect
V _{CC}	Device Power Supply

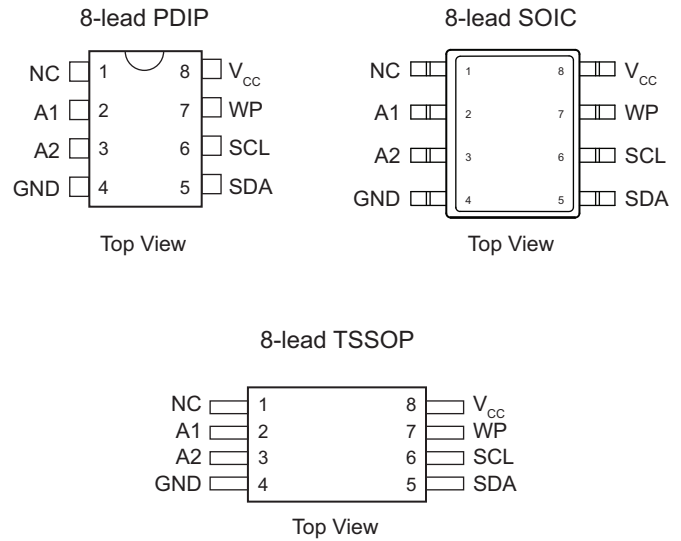

Note: Drawings are not to scale.

2. Absolute Maximum Ratings*

Operating Temperature	-40°C to +125°C
Storage Temperature	-65°C to +150°C
Voltage on Any Pin with Respect to Ground	-1.0V to +7.0V
Maximum Operating Voltage	6.25V
DC Output Current	5.0 mA

*Notice: Stresses beyond those listed under “Absolute Maximum Ratings” may cause permanent damage to the device. This is a stress rating only and functional operation of the device at these or any other conditions beyond those indicated in the operational sections of this specification is not implied. Exposure to absolute maximum rating conditions for extended periods may affect device reliability.

3. Block Diagram

Figure 3-1. Block Diagram

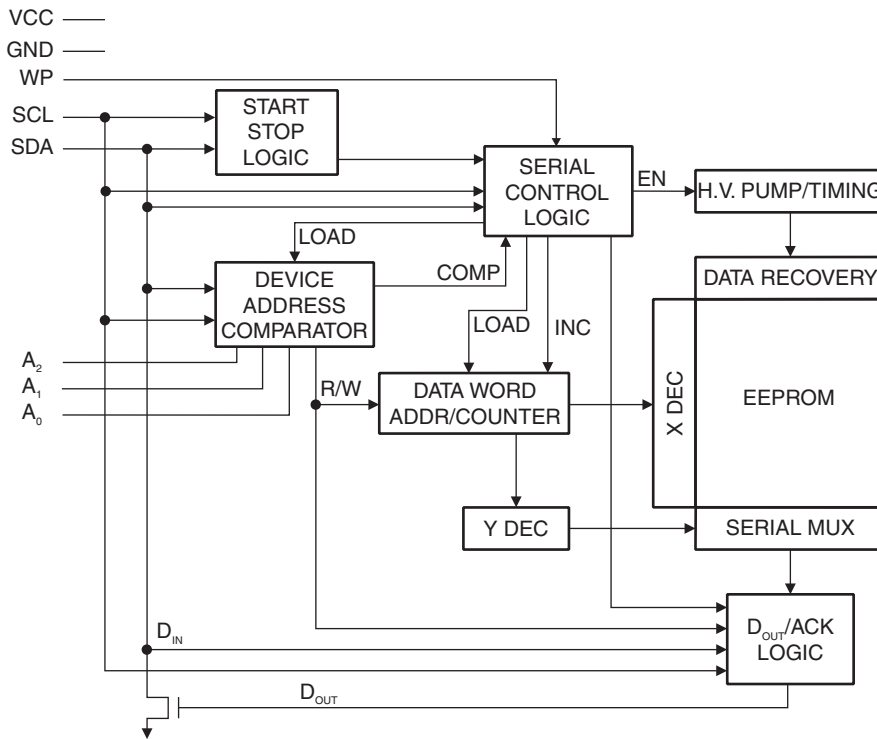

4. Pin Description

Serial Clock (SCL): The SCL input is used to positive edge clock data into each EEPROM device and negative edge clock data out of each device.

Serial Data (SDA): The SDA pin is bidirectional for serial data transfer. This pin is open-drain driven and may be wire-ORed with any number of other open-drain or open collector devices.

Device/Page Addresses (A₂, A₁, and A₀): The A₂ and A₁ pins are device address inputs that must be hardwired for the AT24HC04B. As many as four 4K devices may be addressed on a single bus system. The A₀ pin is a no connect. (Device addressing and Page addressing are discussed in detail in [Section 7.](#), “Device Addressing and Page Addressing”).

Write Protect (WP): The AT24HC04B has a WP pin which provides hardware data protection. The WP pin allows normal read/write operations when connected to ground (GND). When the WP pin is connected to V_{CC}, the write protection feature is enabled and operates as shown.

Table 4-1. Write Protect

WP Pin Status	Part of the Array Protected
At V _{CC}	Upper Half (2K) Array
At GND	Normal Read/Write Operations

5. Memory Organization

AT24HC04B, 4K Serial EEPROM: The 4K is internally organized with 32 pages of 16 bytes each. Random word addressing requires an 9-bit data word address.

5.1 Pin Capacitance ⁽¹⁾

Applicable over recommended operating range from $T_{AI} = 25^{\circ}\text{C}$, $f = 1.0\text{MHz}$, $V_{CC} = +1.8\text{V}$.

Symbol	Test Condition	Max	Units	Conditions
$C_{I/O}$	Input/Output Capacitance (SDA)	8	pF	$V_{I/O} = 0\text{V}$
C_{IN}	Input Capacitance (A_0 , A_1 , A_2 , and SCL)	6	pF	$V_{IN} = 0\text{V}$

Note: 1. This parameter is characterized and is not 100% tested.

5.2 DC Characteristics

Applicable over recommended operating range from: $T_{AI} = -40^{\circ}\text{C}$ to $+85^{\circ}\text{C}$, $V_{CC} = +1.8\text{V}$ to $+5.5\text{V}$ (unless otherwise noted).

Symbol	Parameter	Test Condition	Min	Typ	Max	Units
V_{CC1}	Supply Voltage		1.80		5.50	V
V_{CC2}	Supply Voltage		2.50		5.50	V
V_{CC3}	Supply Voltage		2.70		5.50	V
V_{CC4}	Supply Voltage		4.50		5.50	V
I_{CC}	Supply Current $V_{CC} = 5.0\text{V}$	Read at 100kHz		0.40	1	mA
I_{CC}	Supply Current $V_{CC} = 5.0\text{V}$	Write at 100kHz		2	3	mA
I_{SB1}	Standby Current $V_{CC} = 1.8\text{V}$	$V_{IN} = V_{CC}$ or V_{SS}		0.60	3	μA
I_{SB2}	Standby Current $V_{CC} = 2.5\text{V}$	$V_{IN} = V_{CC}$ or V_{SS}		1.40	4	μA
I_{SB3}	Standby Current $V_{CC} = 2.7\text{V}$	$V_{IN} = V_{CC}$ or V_{SS}		1.60	4	μA
I_{SB4}	Standby Current $V_{CC} = 5.0\text{V}$	$V_{IN} = V_{CC}$ or V_{SS}		8	18	μA
I_{LI}	Input Leakage Current	$V_{IN} = V_{CC}$ or V_{SS}		0.10	3	μA
I_{LO}	Output Leakage Current	$V_{OUT} = V_{CC}$ or V_{SS}		0.05	3	μA
V_{IL}	Input Low Level ⁽¹⁾		-0.60		$V_{CC} \times 0.30$	V
V_{IH}	Input High Level ⁽¹⁾		$V_{CC} \times 0.70$		$V_{CC} + 0.50$	V
V_{OL2}	Output Low Level $V_{CC} = 3.0\text{V}$	$I_{OL} = 2.10\text{mA}$			0.40	V
V_{OL1}	Output Low Level $V_{CC} = 1.8\text{V}$	$I_{OL} = 0.15\text{mA}$			0.20	V

Note: 1. V_{IL} min and V_{IH} max are reference only and are not tested.

Table 5-1. AC Characteristics

Applicable over recommended operating range from $T_{AI} = -40^{\circ}\text{C}$ to $+85^{\circ}\text{C}$, $V_{CC} = +5.5\text{V}$, $CL = 1$ TTL Gate and 100pF (unless otherwise noted). Test conditions are listed in [Note 2](#).

Symbol	Parameter	1.8V, 2.5V, 2.7V		5V		Units
		Min	Max	Min	Max	
f_{SCL}	Clock Frequency, SCL		400		1000	kHz
t_{LOW}	Clock Pulse Width Low	1.20		0.40		μs
t_{HIGH}	Clock Pulse Width High	0.60		0.40		μs
t_I	Noise Suppression Time		50		40	ns
t_{AA}	Clock Low to Data Out Valid	0.10	0.90	0.05	0.55	μs
t_{BUF}	Time the bus must be free before a new transmission can start.	1.20		0.50		μs
$t_{HD.STA}$	Start Hold Time	0.60		0.25		μs
$t_{SU.STA}$	Start Setup Time	0.60		0.25		μs
$t_{HD.DAT}$	Data In Hold Time	0		0		μs
$t_{SU.DAT}$	Data In Setup Time	100		100		ns
t_R	Inputs Rise Time ⁽¹⁾		0.30		0.30	μs
t_F	Inputs Fall Time ⁽¹⁾		300		100	ns
$t_{SU.STO}$	Stop Setup Time	0.60		.25		μs
t_{DH}	Data Out Hold Time	50		50		ns
t_{WR}	Write Cycle Time		5		5	ms
Endurance ⁽¹⁾	5.0V, 25°C, Byte Mode	1,000,000				Write Cycles

- Notes: 1. This parameter is ensured by characterization only.
2. AC measurement conditions:
- R_L (connects to V_{CC}): $1.3\text{k}\Omega$ (2.5V, 5.5V), $10\text{k}\Omega$ (1.7V)
 - Input pulse voltages: $0.3V_{CC}$ to $0.7V_{CC}$
 - Input rise and fall times: $\leq 50\text{ns}$
 - Input and output timing reference voltages: $0.5 \times V_{CC}$

6. Device Operation

Clock and Data Transitions: The SDA pin is normally pulled high with an external device. Data on the SDA pin may change only during SCL low time periods. Data changes during SCL high periods will indicate a Start or Stop condition as defined below.

Figure 6-1. Data Validity

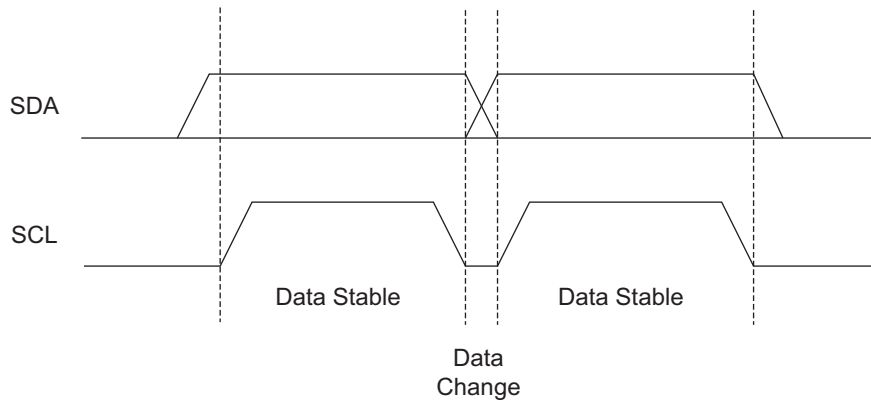

Start Condition: A high-to-low transition of SDA with SCL high is a Start condition that must precede any other command.

Stop Condition: A low-to-high transition of SDA with SCL high is a Stop condition. After a read sequence, the Stop condition will place the EEPROM in a standby power mode.

Figure 6-2. Start and Stop Definition

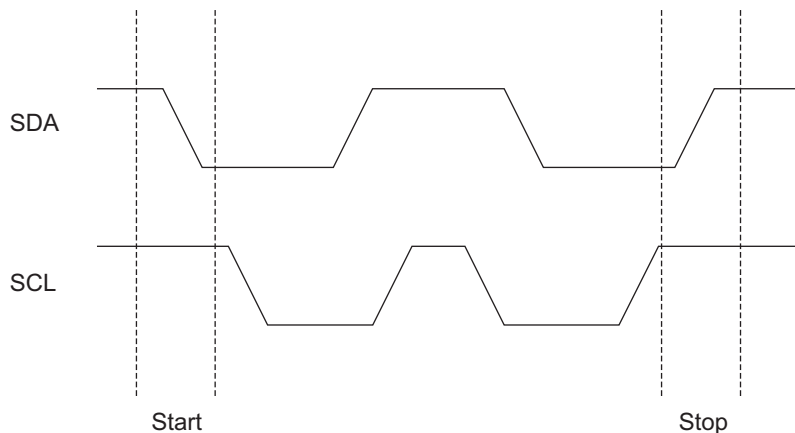

Acknowledge: All addresses and data words are serially transmitted to and from the EEPROM in 8-bit words. The EEPROM sends a zero to acknowledge that it has received each word. This happens during the ninth clock cycle.

Figure 6-3. Output Acknowledge

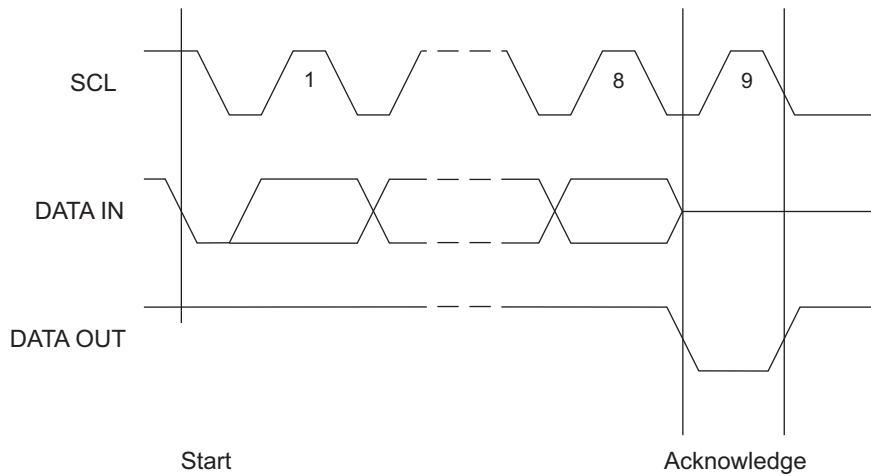

Standby Mode: The AT24HC04B features a low-power standby mode that is enabled:

- Upon power-up.
- After the receipt of the Stop condition, and the completion of any internal operations.

2-Wire Software Reset: After an interruption in protocol, power loss or system reset, any 2-wire part can be protocol reset by following these steps:

1. Create a start condition (if possible).
2. Clock nine cycles.
3. Create another Start condition followed by Stop condition as shown below.

The device should be ready for the next communication after above steps have been completed. In the event that the device is still non-responsive or remains active on the SDA bus, a power cycle must be used to reset the device.

Figure 6-4. Software Reset

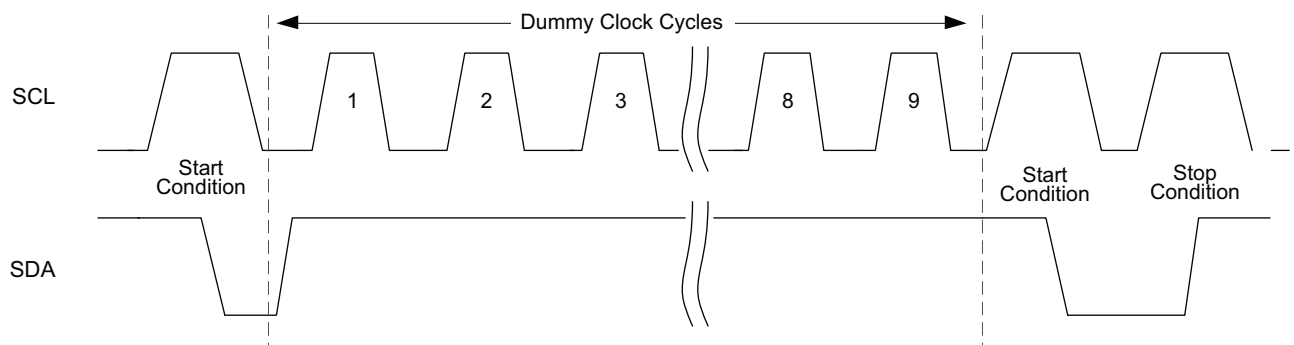

Figure 6-5. Bus Timing

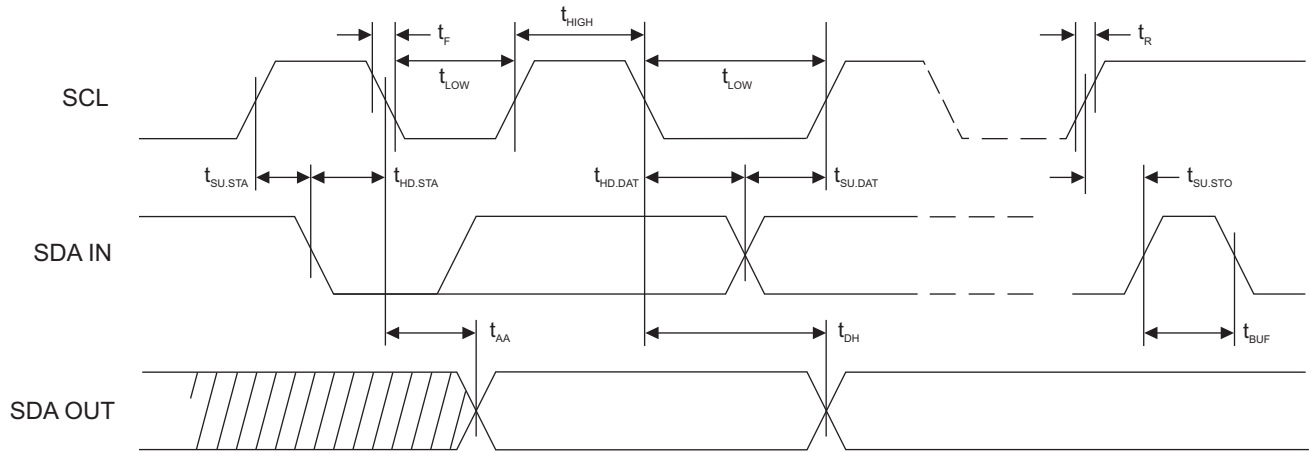
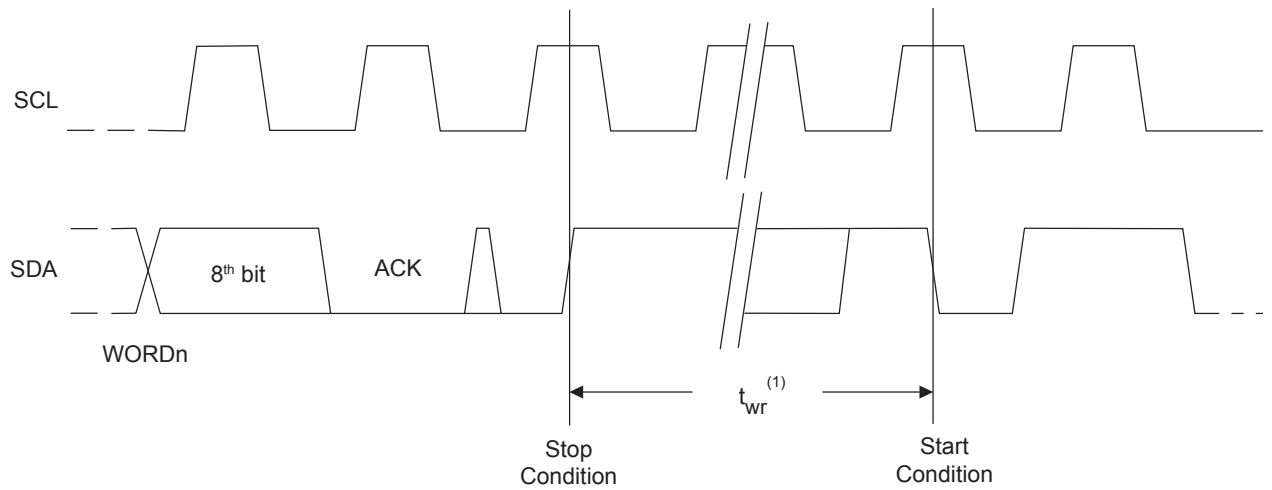

Figure 6-6. Write Cycle Timing



Note: 1. The write cycle time t_{wr} is the time from a valid Stop condition of a write sequence to the end of the internal clear/write cycle.

7. Device Addressing and Page Addressing

The 4K EEPROM device requires an 8-bit device address word following a Start condition to enable the chip for a read or write operation, as shown in the below figure.

Figure 7-1. Device Address

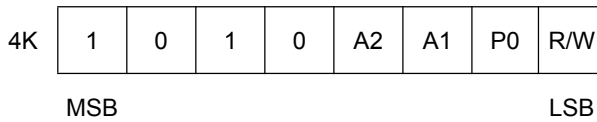

The device address word consists of a mandatory “1”, “0” sequence for the first four most significant bits as shown. This is common to all the EEPROM devices.

The next two bits are the A2 and A1 device address bits for the 4K EEPROM. These two bits must compare to their corresponding hardwired input pins. The A0 pin is a no connect.

The next bit is the memory page address bit. This bit is the MSB of the 9-bit data word address.

The eighth bit of the device address is the read/write operation select bit. A read operation is initiated if this bit is high, and a write operation is initiated if this bit is low.

Upon a compare of the device address, the EEPROM will output a zero. If a compare is not made, the chip will return to a standby state.

8. Write Operations

Byte Write: A Write operation requires an 8-bit data word address following the device address word and acknowledgement. Upon receipt of this address, the EEPROM will again respond with a zero, and then clock in the first 8-bit data word. Following receipt of the 8-bit data word, the EEPROM will output a zero and the addressing device, such as a microcontroller, must terminate the write sequence with a Stop condition. At this time, the EEPROM enters an internally-timed write cycle, t_{WR} , to the nonvolatile memory. All inputs are disabled during this write cycle, and the EEPROM will not respond until the write is complete.

Figure 8-1. Byte Write

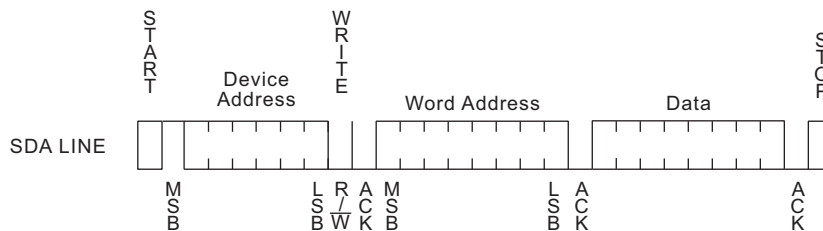

Page Write: The 4K EEPROM is capable of a 16-byte Page Write.

A Page Write is initiated the same as a Byte Write, but the microcontroller does not send a Stop condition after the first data word is clocked in. Instead, after the EEPROM acknowledges receipt of the first data word, the microcontroller can transmit up to fifteen more data words. The EEPROM will respond with a zero after each data word received. The microcontroller must terminate the Page Write sequence with a Stop condition.

The data word address lower four bits are internally incremented following the receipt of each data word. The higher data word address bits are not incremented, retaining the memory page row location. When the word address, internally generated, reaches the page boundary, the following byte is placed at the beginning of the same page. If more than sixteen data words are transmitted to the EEPROM, the data word address will roll-over and previous data will be overwritten.

Figure 8-2. Page Write

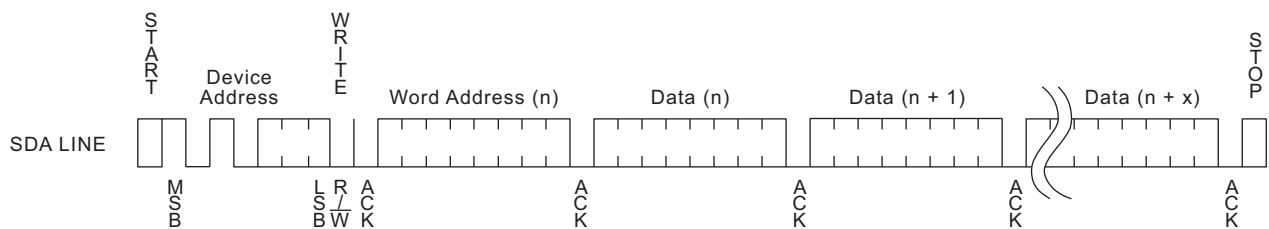

Acknowledge Polling: Once the internally-timed write cycle has started and the EEPROM inputs are disabled, Acknowledge Polling can be initiated. This involves sending a Start condition followed by the device address word. The Read/Write bit is representative of the operation desired. Only if the internal write cycle has completed will the EEPROM respond with a zero allowing the read or write sequence to continue.

9. Read Operations

Read operations are initiated the same way as Write operations with the exception that the Read/Write select bit in the device address word is set to one. There are three Read operations:

- Current Address Read
- Random Address Read
- Sequential Read

Current Address Read: The internal data word address counter maintains the last address accessed during the last Read or Write operation, incremented by one. This address stays valid between operations as long as the chip power is maintained. The address roll-over during read is from the last byte of the last memory page to the first byte of the first page. The address roll-over during write is from the last byte of the current page to the first byte of the same page.

Once the device address with the Read/Write select bit set to one is clocked in and acknowledged by the EEPROM, the current address data word is serially clocked out. The microcontroller does not respond with an input zero but does generate a following Stop condition.

Figure 9-1. Current Address Read

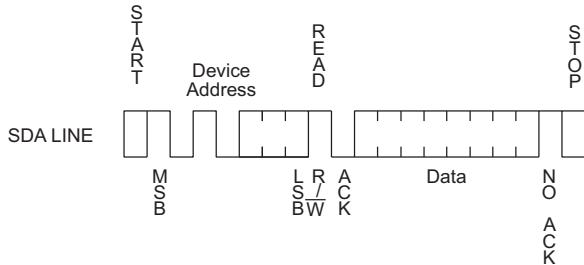

Random Read: A Random Read requires a dummy byte write sequence to load in the data word address. Once the device address word and data word address are clocked in and acknowledged by the EEPROM, the microcontroller must generate another Start condition. The microcontroller now initiates a Current Address Read by sending a device address with the Read/Write select bit high. The EEPROM acknowledges the device address and serially clocks out the data word. The microcontroller does not respond with a zero but does generate a following Stop condition.

Figure 9-2. Random Read

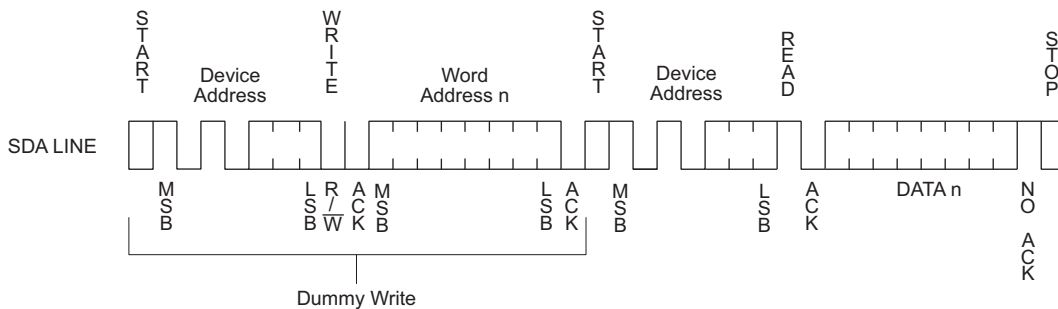

Sequential Read: Sequential Reads are initiated by either a current address read or a Random Address Read. After the microcontroller receives a data word, it responds with an acknowledge. As long as the EEPROM receives an Acknowledge, it will continue to increment the data word address and serially clock out sequential data words. When the memory address limit is reached, the data word address will roll-over and the Sequential Read will continue. The Sequential Read operation is terminated when the microcontroller does not respond with a zero but does generate a following Stop condition.

Figure 9-3. Sequential Read

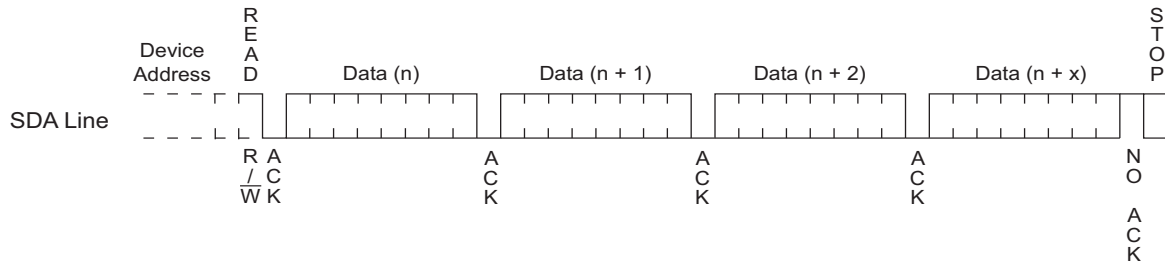

10. Ordering Code Detail

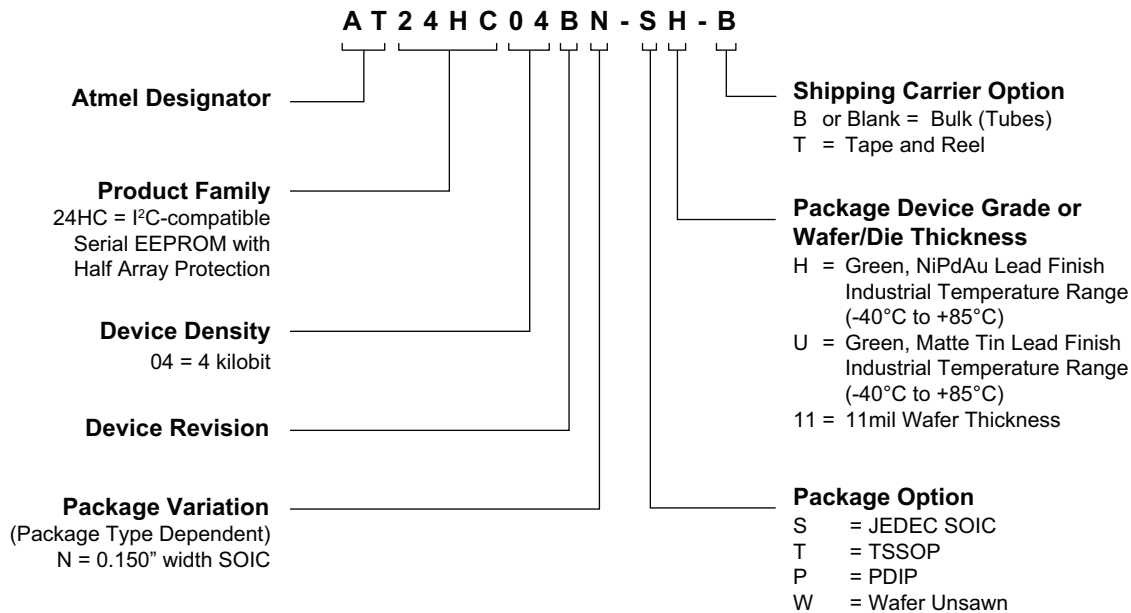

11. Ordering Code Information



Atmel Ordering Code	Lead Finish	Package	Voltage	Delivery Information		Operation Range
				Form	Quantity	
AT24HC04B-PU	Matte Tin (Lead-free/Halogen-free)	8P3	1.8V	Bulk (Tubes)	50 per Tube	Industrial Temperature (-40°C to 85°C)
AT24HC04BN-SH-B	NiPdAu (Lead-free/Halogen-free)	8S1		Bulk (Tubes)	100 per Tube	
AT24HC04BN-SH-T				Tape and Reel	4,000 per Reel	
AT24HC04B-TH-B		8X		Bulk (Tubes)	100 per Tube	
AT24HC04B-TH-T				Tape and Reel	5,000 per Reel	
AT24HC04B-W-11	N/A	Wafer Sale		Note 1		

Note: 1. Available in tape and reel and wafer form; order as SL788 for inkless wafer form. Bumped die available upon request. Please contact the Atmel sales office.

Package Type	
8P3	8-pin, 0.30" wide, Plastic Dual Inline (PDIP)
8S1	8-lead, 0.15" wide, Plastic Gull Wing Small Outline (JEDEC SOIC)
8X	8-lead, 4.40mm body, Plastic Thin Shrink Small Outline (TSSOP)

12. Part Marking Scheme

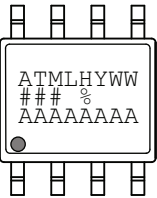
AT24HC04B Package Marking Information

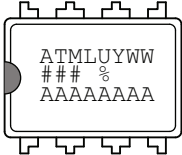
8-lead SOIC	8-lead TSSOP	8-lead PDIP
	 <p><i>Note: Lot Number and location of assembly and on the bottom side of the package.</i></p>	

Note 1: ● designates pin 1

Note 2: Package drawings are not to scale

Catalog Number Truncation			
AT24HC04B		Truncation Code ###: H4B	
Date Codes			Voltages
Y = Year	M = Month	WW = Work Week of Assembly	% = Minimum Voltage
4: 2014 8: 2018	A: January	02: Week 2	1: 1.8V min
5: 2015 9: 2019	B: February	04: Week 4	
6: 2016 0: 2020	
7: 2017 1: 2021	L: December	52: Week 52	
Country of Assembly	Lot Number	Grade/Lead Finish Material	
@ = Country of Assembly	AAA...A = Atmel Wafer Lot Number	U: Industrial/Matte Tin/SnAgCu H: Industrial/NiPdAu	
Trace Code			Atmel Truncation
XX = Trace Code (Atmel Lot Numbers Correspond to Code) Example: AA, AB.... YZ, ZZ			AT: Atmel ATM: Atmel ATML: Atmel

6/10/15

 Package Mark Contact: DL-CSO-Assy_eng@atmel.com	TITLE 24HC04BSM, AT24HC04B Package Marking Information	DRAWING NO. 24HC04BSM	REV. B
---	---	---------------------------------	------------------

13. Packaging Information

13.1 8P3 — 8-lead PDIP

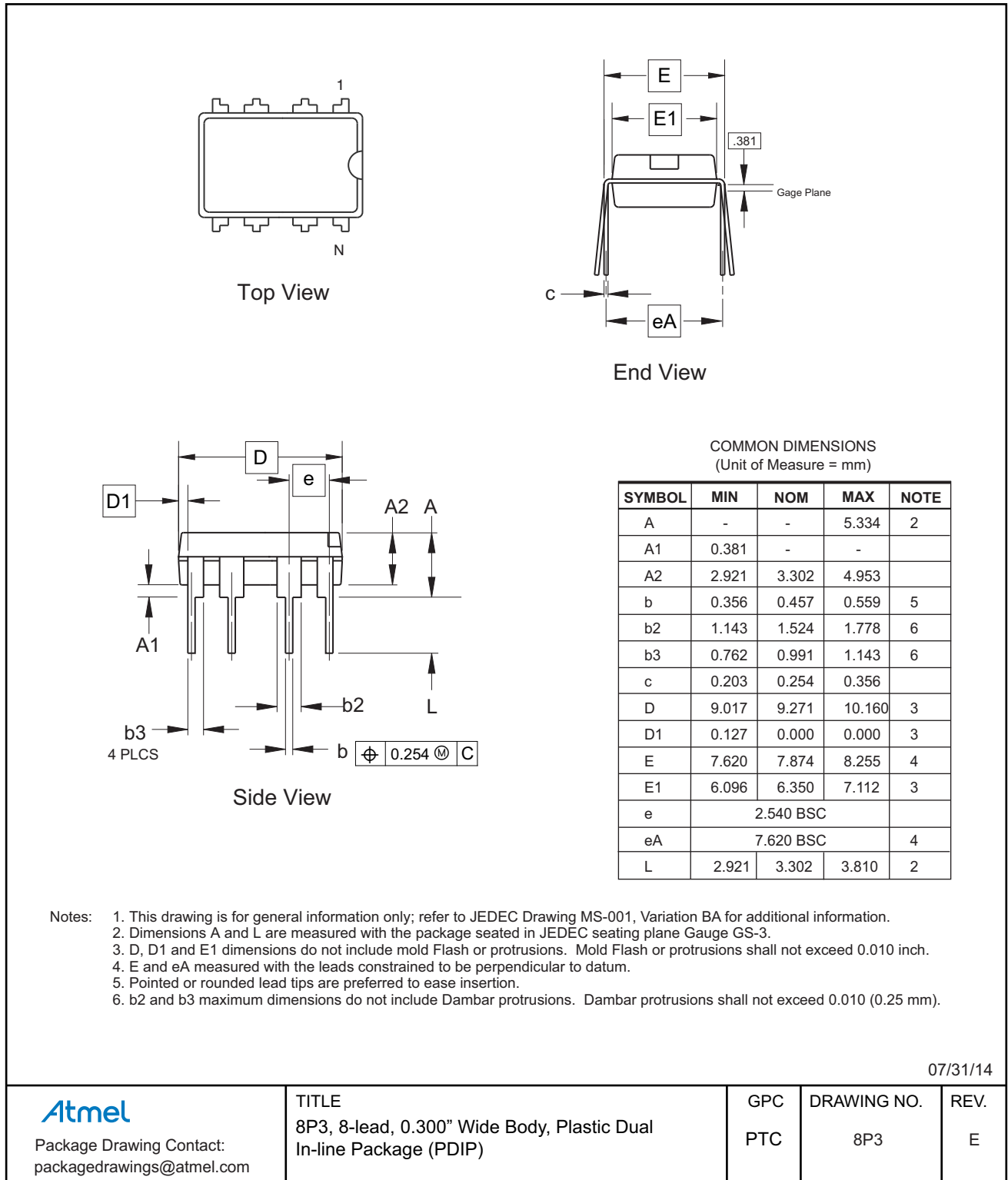

13.2 8S1 — 8-lead JEDEC SOIC

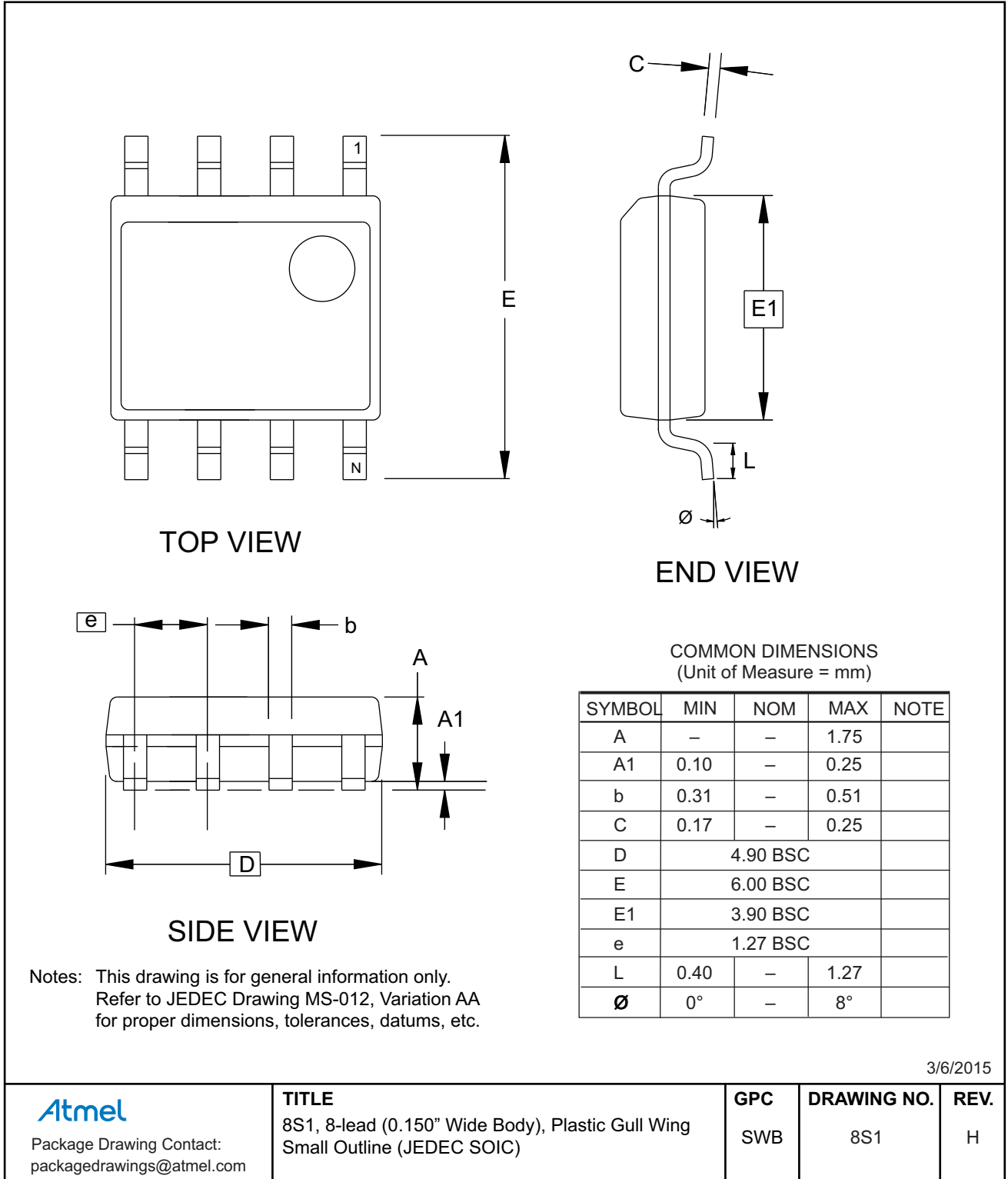

13.3 8X — 8-lead TSSOP

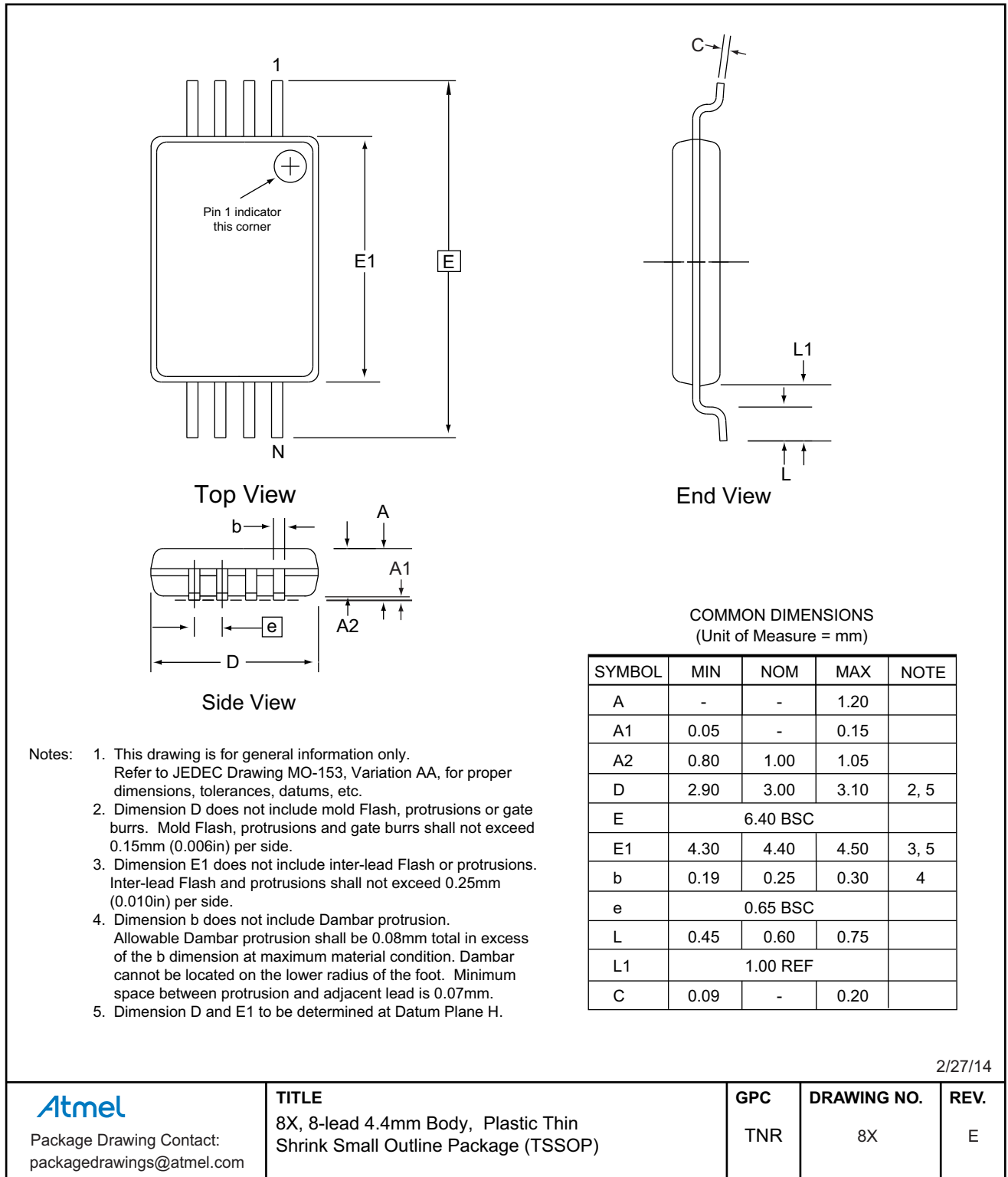

14. Revision History

Doc. Rev.	Date	Comments
5227H	12/2015	Corrected the ordering code detail.
5227G	06/2015	Updated package drawings, ordering code table, and part marking page. Added the ordering code detail.
5227F	02/2014	Updated Atmel template (no changes to functional specification). logos, and disclaimer page, part markings to a single page, and package drawings 8P3, 8S1, and 8A2 to 8X. Updated the Random Read figure and add the AC measurement conditions note to the AC Characteristics table.
5227E	11/2008	Updated pin configurations.
5227D	01/2008	Removed 'preliminary' status.
5227C	08/2007	Added Part Marking Scheme.
5227B	08/2007	Updated to new template and common figures. Added Part Marking tables.
5227A	04/2007	Initial document release.

X-ON Electronics

Largest Supplier of Electrical and Electronic Components

Click to view similar products for [EEPROM](#) category:

Click to view products by [Microchip](#) manufacturer:

Other Similar products are found below :

[M29F040-70K6](#) [718278CB](#) [718620G](#) [444358RB](#) [444362FB](#) [BR93C46-WMN7TP](#) [EEROMH](#) [CAT25320YIGT-KK](#) [LE24C162-R-E](#) [5962-8751409YA](#) [BR9016AF-WE2](#) [LE2464DXATBG](#) [CAS93C66VP2I-GT3](#) [W60002FT20T](#) [CAT24S128C4UTR](#) [ZD24C64B-SSGMA0](#) [BL24C04F-RRRC](#) [S-25C040A0I-I8T1U](#) [AT24C256BY7-YH-T](#) [M24C64-DFCT6TPK](#) [BR24C21FJ-E2](#) [BR24G02FVJ-3GTE2](#) [BR24L16FJ-WE2](#) [BR24L16FVJ-WE2](#) [BR24S16FJ-WE2](#) [BR24S256F-WE2](#) [BR93L56RFV-WE2](#) [BR93L66F-WE2](#) [BR93L76RFV-WE2](#) [CAT24C64C4CTR](#) [CHL24C32WEGT3](#) [AT28HC256E-12SU-T](#) [AT93C46DY6-YH-T](#) [93LC66BT-I/ST](#) [BR24T02FVT-WSGE2](#) [M35B32-WMN6TP](#) [M24C64-FMC6TG](#) [M24C08-WDW6TP](#) [CAT25080VP2IGTQH](#) [CAT25020ZIGT-QP](#) [CAT24C01VP2I-GT3](#) [CAT93C76BZI-GT3](#) [CAT64LC40WI-T3](#) [CAT25256HU4E-GT3](#) [CAT25128VP2I-GT3](#) [CAT25040VP2I-GT3](#) [CAT25020VP2I-GT3](#) [CAT24C16ZI-G](#) [CAT24C05LI-G](#) [CAT24C01ZI-G](#)