

Features

- Incorporates the ARM7TDMI® ARM® Thumb® Processor
 - High-performance 32-bit RISC Architecture
 - High-density 16-bit Instruction Set
 - Leader in MIPS/Watt
 - EmbeddedICE™ In-circuit Emulation, Debug Communication Channel Support
- Internal High-speed Flash
 - 512 Kbytes, Organized in Two Contiguous Banks of 1024 Pages of 256 Bytes Dual Plane (SAM7SE512)
 - 256 Kbytes (SAM7SE256) Organized in One Bank of 1024 Pages of 256 Bytes Single Plane (SAM7SE256)
 - 32 Kbytes (SAM7SE32) Organized in One Bank of 256 Pages of 128 Bytes Single Plane (SAM7SE32)
 - Single Cycle Access at Up to 30 MHz in Worst Case Conditions
 - Prefetch Buffer Optimizing Thumb Instruction Execution at Maximum Speed
 - Page Programming Time: 6 ms, Including Page Auto-erase, Full Erase Time: 15 ms
 - 10,000 Erase Cycles, 10-year Data Retention Capability, Sector Lock Capabilities, Flash Security Bit
 - Fast Flash Programming Interface for High Volume Production
- 32 Kbytes (SAM7SE512/256) or 8 Kbytes (SAM7SE32) of Internal High-speed SRAM, Single-cycle Access at Maximum Speed
- One External Bus Interface (EBI)
 - Supports SDRAM, Static Memory, Glueless Connection to CompactFlash® and ECC-enabled NAND Flash
- Memory Controller (MC)
 - Embedded Flash Controller
 - Memory Protection Unit
 - Abort Status and Misalignment Detection
- Reset Controller (RSTC)
 - Based on Power-on Reset Cells and Low-power Factory-calibrated Brownout Detector
 - Provides External Reset Signal Shaping and Reset Source Status
- Clock Generator (CKGR)
 - Low-power RC Oscillator, 3 to 20 MHz On-chip Oscillator and One PLL
- Power Management Controller (PMC)
 - Power Optimization Capabilities, Including Slow Clock Mode (Down to 500 Hz) and Idle Mode
 - Three Programmable External Clock Signals
- Advanced Interrupt Controller (AIC)
 - Individually Maskable, Eight-level Priority, Vectored Interrupt Sources
 - Two External Interrupt Sources and One Fast Interrupt Source, Spurious Interrupt Protected
- Debug Unit (DBGU)
 - Two-wire UART and Support for Debug Communication Channel interrupt, Programmable ICE Access Prevention
 - Mode for General Purpose Two-wire UART Serial Communication
- Periodic Interval Timer (PIT)
 - 20-bit Programmable Counter plus 12-bit Interval Counter
- Windowed Watchdog (WDT)
 - 12-bit key-protected Programmable Counter



AT91SAM ARM-based Flash MCU

SAM7SE512
SAM7SE256
SAM7SE32

Summary

NOTE: This is a summary document.
The complete document is available on
the Atmel website at www.atmel.com.

6222GS-ATARM-6-Sep-11



- Provides Reset or Interrupt Signals to the System
- Counter May Be Stopped While the Processor is in Debug State or in Idle Mode
- Real-time Timer (RTT)
 - 32-bit Free-running Counter with Alarm
 - Runs Off the Internal RC Oscillator
- Three Parallel Input/Output Controllers (PIO)
 - Eighty-eight Programmable I/O Lines Multiplexed with up to Two Peripheral I/Os
 - Input Change Interrupt Capability on Each I/O Line
 - Individually Programmable Open-drain, Pull-up Resistor and Synchronous Output
 - Schmitt Trigger on All inputs
- Eleven Peripheral DMA Controller (PDC) Channels
- One USB 2.0 Full Speed (12 Mbits per second) Device Port
 - On-chip Transceiver, Eight Endpoints, 2688-byte Configurable Integrated FIFOs
- One Synchronous Serial Controller (SSC)
 - Independent Clock and Frame Sync Signals for Each Receiver and Transmitter
 - I²S Analog Interface Support, Time Division Multiplex Support
 - High-speed Continuous Data Stream Capabilities with 32-bit Data Transfer
- Two Universal Synchronous/Asynchronous Receiver Transmitters (USART)
 - Individual Baud Rate Generator, IrDA[®] Infrared Modulation/Demodulation
 - Support for ISO7816 T0/T1 Smart Card, Hardware Handshaking, RS485 Support
 - Full Modem Line Support on USART1
- One Master/Slave Serial Peripheral Interfaces (SPI)
 - 8- to 16-bit Programmable Data Length, Four External Peripheral Chip Selects
- One Three-channel 16-bit Timer/Counter (TC)
 - Three External Clock Inputs, Two Multi-purpose I/O Pins per Channel
 - Double PWM Generation, Capture/Waveform Mode, Up/Down Capability
- One Four-channel 16-bit PWM Controller (PWMC)
- One Two-wire Interface (TWI)
 - Master, Multi-Master and Slave Mode Support, All Two-wire Atmel EEPROMs Supported
 - General Call Supported in Slave Mode
- One 8-channel 10-bit Analog-to-Digital Converter, Four Channels Multiplexed with Digital I/Os
- SAM-BA[®]
 - Default Boot program
 - Interface with SAM-BA Graphic User Interface
- IEEE[®] 1149.1 JTAG Boundary Scan on All Digital Pins
- Four High-current Drive I/O lines, Up to 16 mA Each
- Power Supplies
 - Embedded 1.8V Regulator, Drawing up to 100 mA for the Core and External Components
 - 1.8V or 3.3V VDDIO I/O Lines Power Supply, Independent 3.3V VDDFLASH Flash Power Supply
 - 1.8V VDDCORE Core Power Supply with Brownout Detector
- Fully Static Operation:
 - Up to 55 MHz at 1.8V and 85° C Worst Case Conditions
 - Up to 48 MHz at 1.65V and 85° C Worst Case Conditions
- Available in a 128-lead LQFP Green Package, or a 144-ball LFBGA RoHS-compliant Package

1. Description

Atmel's SAM7SE Series is a member of its Smart ARM Microcontroller family based on the 32-bit ARM7™ RISC processor and high-speed Flash memory.

- SAM7SE512 features a 512-Kbyte high-speed Flash and a 32 Kbyte SRAM.
- SAM7SE256 features a 256-Kbyte high-speed Flash and a 32 Kbyte SRAM.
- SAM7SE32 features a 32-Kbyte high-speed Flash and an 8 Kbyte SRAM.

It also embeds a large set of peripherals, including a USB 2.0 device, an External Bus Interface (EBI), and a complete set of system functions minimizing the number of external components.

The EBI incorporates controllers for synchronous DRAM (SDRAM) and Static memories and features specific circuitry facilitating the interface for NAND Flash, SmartMedia and CompactFlash.

The device is an ideal migration path for 8/16-bit microcontroller users looking for additional performance, extended memory and higher levels of system integration.

The embedded Flash memory can be programmed in-system via the JTAG-ICE interface or via a parallel interface on a production programmer prior to mounting. Built-in lock bits and a security bit protect the firmware from accidental overwrite and preserve its confidentiality.

The SAM7SE Series system controller includes a reset controller capable of managing the power-on sequence of the microcontroller and the complete system. Correct device operation can be monitored by a built-in brownout detector and a watchdog running off an integrated RC oscillator.

By combining the ARM7TDMI processor with on-chip Flash and SRAM, and a wide range of peripheral functions, including USART, SPI, External Bus Interface, Timer Counter, RTT and Analog-to-Digital Converters on a monolithic chip, the SAM7SE512/256/32 is a powerful device that provides a flexible, cost-effective solution to many embedded control applications.

1.1 Configuration Summary of the SAM7SE512, SAM7SE256 and SAM7SE32

The SAM7SE512, SAM7SE256 and SAM7SE32 differ in memory sizes and organization. [Table 1-1](#) below summarizes the configurations for the three devices.

Table 1-1. Configuration Summary

Device	Flash Size	Flash Organization	RAM Size
SAM7SE512	512K bytes	dual plane	32K bytes
SAM7SE256	256K bytes	single plane	32K bytes
SAM7SE32	32K bytes	single plane	8K bytes

2. Block Diagram

Figure 2-1. SAM7SE512/256/32 Block Diagram Signal Description

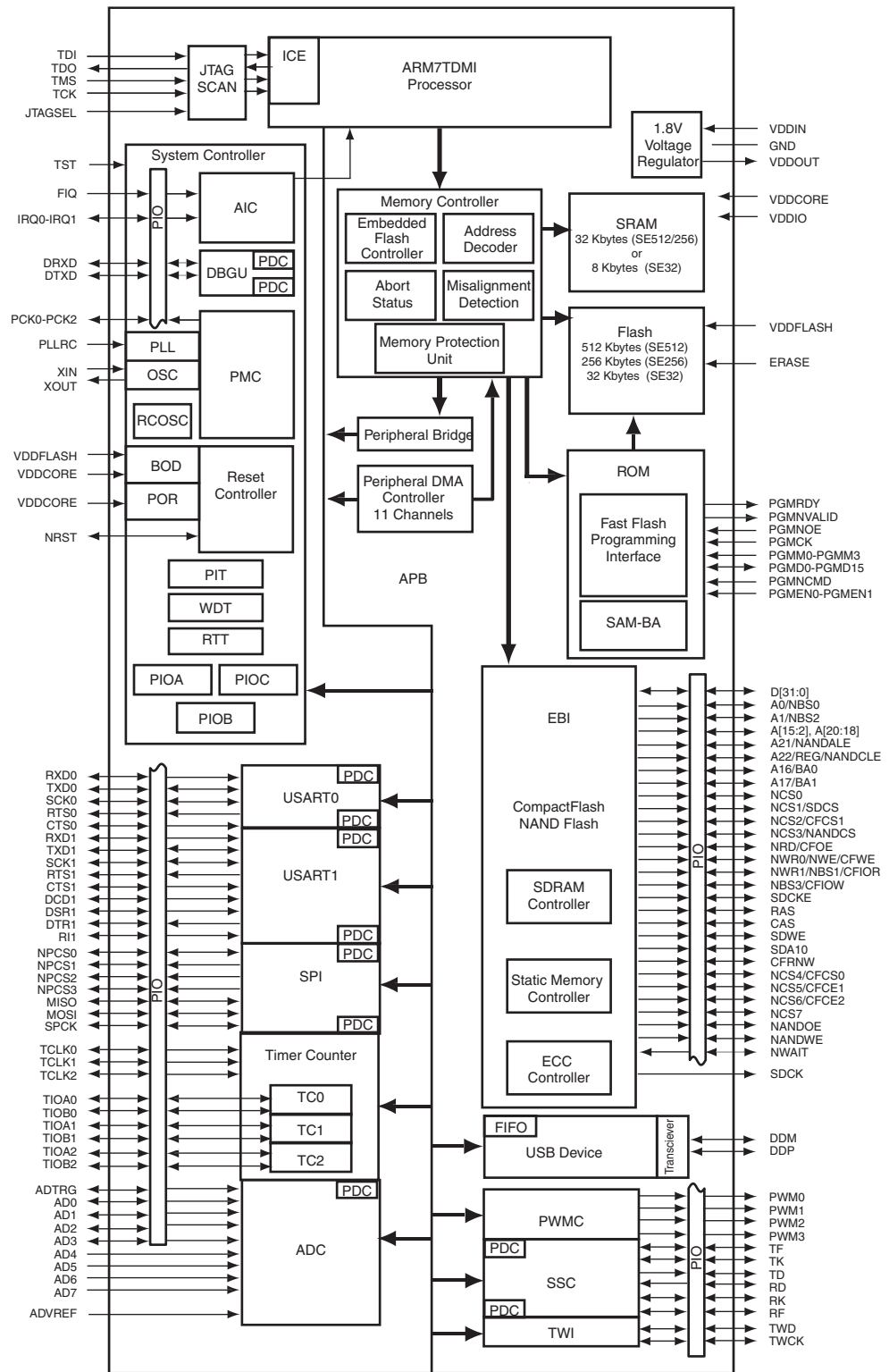

3. Signal Description

Table 3-1. Signal Description List

Signal Name	Function	Type	Active Level	Comments
Power				
VDDIN	Voltage Regulator and ADC Power Supply Input	Power		3V to 3.6V
VDDOUT	Voltage Regulator Output	Power		1.85V
VDDFLASH	Flash and USB Power Supply	Power		3V to 3.6V
VDDIO	I/O Lines Power Supply	Power		3V to 3.6V or 1.65V to 1.95V
VDDCORE	Core Power Supply	Power		1.65V to 1.95V
VDDPLL	PLL	Power		1.65V to 1.95V
GND	Ground	Ground		
Clocks, Oscillators and PLLs				
XIN	Main Oscillator Input	Input		
XOUT	Main Oscillator Output	Output		
PLLRC	PLL Filter	Input		
PCK0 - PCK2	Programmable Clock Output	Output		
ICE and JTAG				
TCK	Test Clock	Input		No pull-up resistor
TDI	Test Data In	Input		No pull-up resistor
TDO	Test Data Out	Output		
TMS	Test Mode Select	Input		No pull-up resistor.
JTAGSEL	JTAG Selection	Input		Pull-down resistor ⁽¹⁾
Flash Memory				
ERASE	Flash and NVM Configuration Bits Erase Command	Input	High	Pull-down resistor ⁽¹⁾
Reset/Test				
NRST	Microcontroller Reset	I/O	Low	Open drain with pull-up resistor ⁽¹⁾
TST	Test Mode Select	Input	High	Pull-down resistor ⁽¹⁾
Debug Unit				
DRXD	Debug Receive Data	Input		
DTXD	Debug Transmit Data	Output		
AIC				
IRQ0 - IRQ1	External Interrupt Inputs	Input		
FIQ	Fast Interrupt Input	Input		



Table 3-1. Signal Description List (Continued)

Signal Name	Function	Type	Active Level	Comments
PIO				
PA0 - PA31	Parallel IO Controller A	I/O		Pulled-up input at reset
PB0 - PB31	Parallel IO Controller B	I/O		Pulled-up input at reset
PC0 - PC23	Parallel IO Controller C	I/O		Pulled-up input at reset
USB Device Port				
DDM	USB Device Port Data -	Analog		
DDP	USB Device Port Data +	Analog		
USART				
SCK0 - SCK1	Serial Clock	I/O		
TXD0 - TXD1	Transmit Data	I/O		
RXD0 - RXD1	Receive Data	Input		
RTS0 - RTS1	Request To Send	Output		
CTS0 - CTS1	Clear To Send	Input		
DCD1	Data Carrier Detect	Input		
DTR1	Data Terminal Ready	Output		
DSR1	Data Set Ready	Input		
RI1	Ring Indicator	Input		
Synchronous Serial Controller				
TD	Transmit Data	Output		
RD	Receive Data	Input		
TK	Transmit Clock	I/O		
RK	Receive Clock	I/O		
TF	Transmit Frame Sync	I/O		
RF	Receive Frame Sync	I/O		
Timer/Counter				
TCLK0 - TCLK2	External Clock Inputs	Input		
TIOA0 - TIOA2	Timer Counter I/O Line A	I/O		
TIOB0 - TIOB2	Timer Counter I/O Line B	I/O		
PWM Controller				
PWM0 - PWM3	PWM Channels	Output		
Serial Peripheral Interface				
MISO	Master In Slave Out	I/O		
MOSI	Master Out Slave In	I/O		
SPCK	SPI Serial Clock	I/O		
NPCS0	SPI Peripheral Chip Select 0	I/O	Low	
NPCS1-NPCS3	SPI Peripheral Chip Select 1 to 3	Output	Low	

Table 3-1. Signal Description List (Continued)

Signal Name	Function	Type	Active Level	Comments
Two-Wire Interface				
TWD	Two-wire Serial Data	I/O		
TWCK	Two-wire Serial Clock	I/O		
Analog-to-Digital Converter				
AD0-AD3	Analog Inputs	Analog		Digital pulled-up inputs at reset
AD4-AD7	Analog Inputs	Analog		Analog Inputs
ADTRG	ADC Trigger	Input		
ADVREF	ADC Reference	Analog		
Fast Flash Programming Interface				
PGMEN0-PGMEN2	Programming Enabling	Input		
PGMM0-PGMM3	Programming Mode	Input		
PGMD0-PGMD15	Programming Data	I/O		
PGMRDY	Programming Ready	Output	High	
PGMNVALID	Data Direction	Output	Low	
PGMNOE	Programming Read	Input	Low	
PGMCK	Programming Clock	Input		
PGMNCMD	Programming Command	Input	Low	
External Bus Interface				
D[31:0]	Data Bus	I/O		
A[22:0]	Address Bus	Output		
NWAIT	External Wait Signal	Input	Low	
Static Memory Controller				
NCS[7:0]	Chip Select Lines	Output	Low	
NWR[1:0]	Write Signals	Output	Low	
NRD	Read Signal	Output	Low	
NWE	Write Enable	Output	Low	
NUB	NUB: Upper Byte Select	Output	Low	
NLB	NLB: Lower Byte Select	Output	Low	
EBI for CompactFlash Support				
CFCE[2:1]	CompactFlash Chip Enable	Output	Low	
CFOE	CompactFlash Output Enable	Output	Low	
CFWE	CompactFlash Write Enable	Output	Low	
CFIOR	CompactFlash I/O Read Signal	Output	Low	
CFIOW	CompactFlash I/O Write Signal	Output	Low	
CFRNW	CompactFlash Read Not Write Signal	Output		
CFCS[1:0]	CompactFlash Chip Select Lines	Output	Low	

Table 3-1. Signal Description List (Continued)

Signal Name	Function	Type	Active Level	Comments
EBI for NAND Flash Support				
NANDCS	NAND Flash Chip Select Line	Output	Low	
NANDOE	NAND Flash Output Enable	Output	Low	
NANDWE	NAND Flash Write Enable	Output	Low	
NANDCLE	NAND Flash Command Line Enable	Output	Low	
NANDALE	NAND Flash Address Line Enable	Output	Low	
SDRAM Controller				
SDCK	SDRAM Clock	Output		Tied low after reset
SDCKE	SDRAM Clock Enable	Output	High	
SDCS	SDRAM Controller Chip Select Line	Output	Low	
BA[1:0]	Bank Select	Output		
SDWE	SDRAM Write Enable	Output	Low	
RAS - CAS	Row and Column Signal	Output	Low	
NBS[3:0]	Byte Mask Signals	Output	Low	
SDA10	SDRAM Address 10 Line	Output		

Note: 1. Refer to [Section 6. "/O Lines Considerations"](#) on page 15.

4. Package

The SAM7SE512/256/32 is available in:

- 20 x 14 mm 128-lead LQFP package with a 0.5 mm lead pitch.
- 10x 10 x 1.4 mm 144-ball LFBGA package with a 0.8 mm lead pitch

4.1 128-lead LQFP Package Outline

Figure 4-1 shows the orientation of the 128-lead LQFP package and a detailed mechanical description is given in the Mechanical Characteristics section of the full datasheet.

Figure 4-1. 128-lead LQFP Package Outline (Top View)

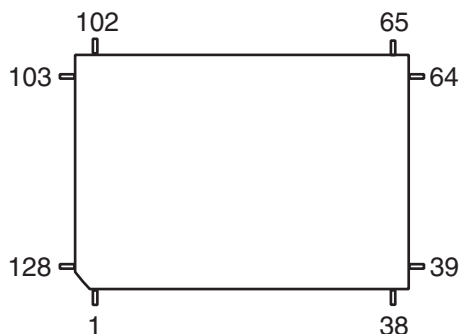

4.2 128-lead LQFP Pinout

Table 4-1. Pinout in 128-lead LQFP Package

1	ADVREF	33	PB31	65	TDI	97	SDCK
2	GND	34	PB30	66	TDO	98	PC8
3	AD7	35	PB29	67	PB2	99	PC7
4	AD6	36	PB28	68	PB1	100	PC6
5	AD5	37	PB27	69	PB0	101	PC5
6	AD4	38	PB26	70	GND	102	PC4
7	VDDOUT	39	PB25	71	VDDIO	103	PC3
8	VDDIN	40	PB24	72	VDDCORE	104	PC2
9	PA20/PGMD8/AD3	41	PB23	73	NRST	105	PC1
10	PA19/PGMD7/AD2	42	PB22	74	TST	106	PC0
11	PA18/PGMD6/AD1	43	PB21	75	ERASE	107	PA31
12	PA17/PGMD5/AD0	44	PB20	76	TCK	108	PA30
13	PA16/PGMD4	45	GND	77	TMS	109	PA29
14	PA15/PGMD3	46	VDDIO	78	JTAGSEL	110	PA28
15	PA14/PGMD2	47	VDDCORE	79	PC23	111	PA27/PGMD15
16	PA13/PGMD1	48	PB19	80	PC22	112	PA26/PGMD14
17	PA12/PGMD0	49	PB18	81	PC21	113	PA25/PGMD13
18	PA11/PGMM3	50	PB17	82	PC20	114	PA24/PGMD12
19	PA10/PGMM2	51	PB16	83	PC19	115	PA23/PGMD11
20	PA9/PGMM1	52	PB15	84	PC18	116	PA22/PGMD10
21	VDDIO	53	PB14	85	PC17	117	PA21/PGMD9
22	GND	54	PB13	86	PC16	118	VDDCORE
23	VDDCORE	55	PB12	87	PC15	119	GND
24	PA8/PGMM0	56	PB11	88	PC14	120	VDDIO
25	PA7/PGMNVALID	57	PB10	89	PC13	121	DM
26	PA6/PGMNOE	58	PB9	90	PC12	122	DP
27	PA5/PGMRDY	59	PB8	91	PC11	123	VDDFLASH
28	PA4/PGMNCMD	60	PB7	92	PC10	124	GND
29	PA3	61	PB6	93	PC9	125	XIN/PGMCK
30	PA2/PGMEN2	62	PB5	94	GND	126	XOUT
31	PA1/PGMEN1	63	PB4	95	VDDIO	127	PLLRC
32	PA0/PGMEN0	64	PB3	96	VDDCORE	128	VDDPLL

4.3 144-ball LFBGA Package Outline

Figure 4-2 shows the orientation of the 144-ball LFBGA package and a detailed mechanical description is given in the Mechanical Characteristics section.

Figure 4-2. 144-ball LFBGA Package Outline (Top View)

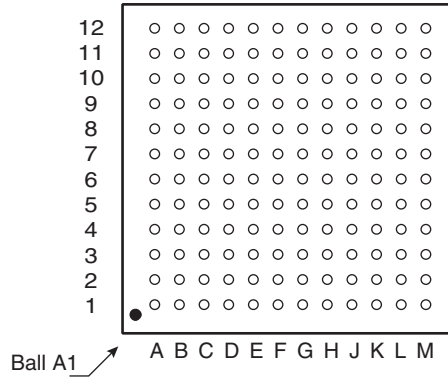

4.4 144-ball LFBGA Pinout

Table 4-2. SAM7SE512/256/32 Pinout for 144-ball LFBGA Package

Pin	Signal Name	Pin	Signal Name	Pin	Signal Name	Pin	Signal Name
A1	PB7	D1	VDDCORE	G1	PC18	K1	PC11
A2	PB8	D2	VDDCORE	G2	PC16	K2	PC6
A3	PB9	D3	PB2	G3	PC17	K3	PC2
A4	PB12	D4	TDO	G4	PC9	K4	PC0
A5	PB13	D5	TDI	G5	VDDIO	K5	PA27/PGMD15
A6	PB16	D6	PB17	G6	GND	K6	PA26/PGMD14
A7	PB22	D7	PB26	G7	GND	K7	GND
A8	PB23	D8	PA14/PGMD2	G8	GND	K8	VDDCORE
A9	PB25	D9	PA12/PGMD0	G9	GND	K9	VDDFLASH
A10	PB29	D10	PA11/PGMM3	G10	AD4	K10	VDDIO
A11	PB30	D11	PA8/PGMM0	G11	VDDIN	K11	VDDIO
A12	PB31	D12	PA7/PGMINVALID	G12	VDDOUT	K12	PA18/PGMD6/AD1
B1	PB6	E1	PC22	H1	PC15	L1	SDCK
B2	PB3	E2	PC23	H2	PC14	L2	PC7
B3	PB4	E3	NRST	H3	PC13	L3	PC4
B4	PB10	E4	TCK	H4	VDDCORE	L4	PC1
B5	PB14	E5	ERASE	H5	VDDCORE	L5	PA29
B6	PB18	E6	TEST	H6	GND	L6	PA24/PGMD12
B7	PB20	E7	VDDCORE	H7	GND	L7	PA21/PGMD9
B8	PB24	E8	VDDCORE	H8	GND	L8	ADVREF
B9	PB28	E9	GND	H9	GND	L9	VDDFLASH
B10	PA4/PGMNCMD	E10	PA9/PGMM1	H10	PA19/PGMD7/AD2	L10	VDDFLASH
B11	PA0/PGMEN0	E11	PA10/PGMM2	H11	PA20/PGMD8/AD3	L11	PA17/PGMD5/AD0
B12	PA1/PGMEN1	E12	PA13/PGMD1	H12	VDDIO	L12	GND
C1	PB0	F1	PC21	J1	PC12	M1	PC8
C2	PB1	F2	PC20	J2	PC10	M2	PC5
C3	PB5	F3	PC19	J3	PA30	M3	PC3
C4	PB11	F4	JTAGSEL	J4	PA28	M4	PA31
C5	PB15	F5	TMS	J5	PA23/PGMD11	M5	PA25/PGMD13
C6	PB19	F6	VDDIO	J6	PA22/PGMD10	M6	DM
C7	PB21	F7	GND	J7	AD6	M7	DP
C8	PB27	F8	GND	J8	AD7	M8	GND
C9	PA6/PGMNOE	F9	GND	J9	VDDCORE	M9	XIN/PGMCK
C10	PA5/PGMRDY	F10	AD5	J10	VDDCORE	M10	XOUT
C11	PA2/PGMEN2	F11	PA15/PGMD3	J11	VDDCORE	M11	PLLRC
C12	PA3	F12	PA16/PGMD4	J12	VDDIO	M12	VDDPLL

5. Power Considerations

5.1 Power Supplies

The SAM7SE512/256/32 has six types of power supply pins and integrates a voltage regulator, allowing the device to be supplied with only one voltage. The six power supply pin types are:

- VDDIN pin. It powers the voltage regulator and the ADC; voltage ranges from 3.0V to 3.6V, 3.3V nominal.
- VDDOUT pin. It is the output of the 1.8V voltage regulator.
- VDDIO pin. It powers the I/O lines; two voltage ranges are supported:
 - from 3.0V to 3.6V, 3.3V nominal
 - or from 1.65V to 1.95V, 1.8V nominal.
- VDDFLASH pin. It powers the USB transceivers and a part of the Flash. It is required for the Flash to operate correctly; voltage ranges from 3.0V to 3.6V, 3.3V nominal.
- VDDCORE pins. They power the logic of the device; voltage ranges from 1.65V to 1.95V, 1.8V typical. It can be connected to the VDDOUT pin with decoupling capacitor. VDDCORE is required for the device, including its embedded Flash, to operate correctly.
- VDDPLL pin. It powers the oscillator and the PLL. It can be connected directly to the VDDOUT pin.

In order to decrease current consumption, if the voltage regulator and the ADC are not used, VDDIN, ADVREF, AD4, AD5, AD6 and AD7 should be connected to GND. In this case VDDOUT should be left unconnected.

No separate ground pins are provided for the different power supplies. Only GND pins are provided and should be connected as shortly as possible to the system ground plane.

5.2 Power Consumption

The SAM7SE512/256/32 has a static current of less than 60 μA on VDDCORE at 25°C, including the RC oscillator, the voltage regulator and the power-on reset when the brownout detector is deactivated. Activating the brownout detector adds 20 μA static current.

The dynamic power consumption on VDDCORE is less than 80 mA at full speed when running out of the Flash. Under the same conditions, the power consumption on VDDFLASH does not exceed 10 mA.

5.3 Voltage Regulator

The SAM7SE512/256/32 embeds a voltage regulator that is managed by the System Controller.

In Normal Mode, the voltage regulator consumes less than 100 μA static current and draws 100 mA of output current.

The voltage regulator also has a Low-power Mode. In this mode, it consumes less than 20 μA static current and draws 1 mA of output current.

Adequate output supply decoupling is mandatory for VDDOUT to reduce ripple and avoid oscillations. The best way to achieve this is to use two capacitors in parallel:

- One external 470 pF (or 1 nF) NPO capacitor should be connected between VDDOUT and GND as close to the chip as possible.

- One external 2.2 μF (or 3.3 μF) X7R capacitor should be connected between VDDOUT and GND.

Adequate input supply decoupling is mandatory for VDDIN in order to improve startup stability and reduce source voltage drop. The input decoupling capacitor should be placed close to the chip. For example, two capacitors can be used in parallel: 100 nF NPO and 4.7 μF X7R.

5.4 Typical Powering Schematics

The SAM7SE512/256/32 supports a 3.3V single supply mode. The internal regulator input connected to the 3.3V source and its output feeds VDDCORE and the VDDPLL. [Figure 5-1](#) shows the power schematics to be used for USB bus-powered systems.

Figure 5-1. 3.3V System Single Power Supply Schematic

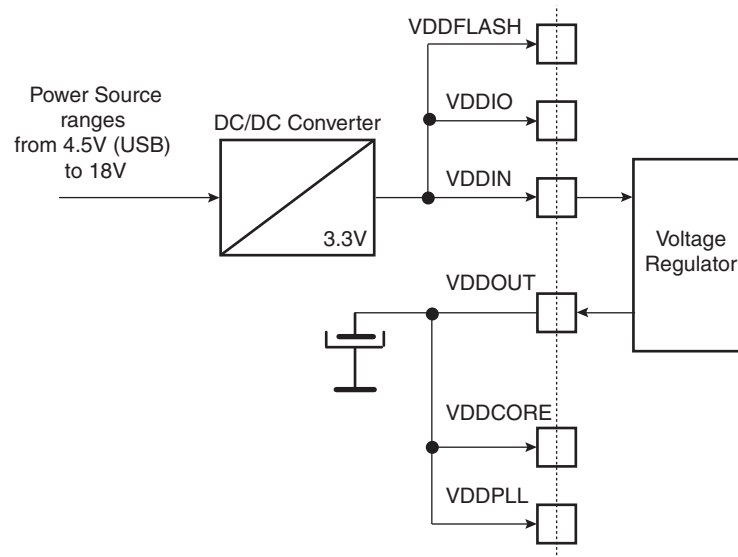

6. /O Lines Considerations

6.1 JTAG Port Pins

TMS, TDI and TCK are Schmitt trigger inputs. TMS, TDI and TCK do not integrate a pull-up resistor.

TDO is an output, driven at up to VDDIO, and has no pull-up resistor.

The JTAGSEL pin is used to select the JTAG boundary scan when asserted at a high level. The JTAGSEL pin integrates a permanent pull-down resistor of about 15 k Ω .

To eliminate any risk of spuriously entering the JTAG boundary scan mode due to noise on JTAGSEL, it should be tied externally to GND if boundary scan is not used, or put in place an external low value resistor (such as 1 k Ω).

6.2 Test Pin

The TST pin is used for manufacturing test or fast programming mode of the SAM7SE512/256/32 when asserted high. The TST pin integrates a permanent pull-down resistor of about 15 k Ω to GND.

To eliminate any risk of entering the test mode due to noise on the TST pin, it should be tied to GND if the FFPI is not used, or put in place an external low value resistor (such as 1 k Ω).

To enter fast programming mode, the TST pin and the PA0 and PA1 pins should be tied high and PA2 tied low.

Driving the TST pin at a high level while PA0 or PA1 is driven at 0 leads to unpredictable results.

6.3 Reset Pin

The NRST pin is bidirectional with an open-drain output buffer. It is handled by the on-chip reset controller and can be driven low to provide a reset signal to the external components or asserted low externally to reset the microcontroller. There is no constraint on the length of the reset pulse, and the reset controller can guarantee a minimum pulse length. This allows connection of a simple push-button on the NRST pin as system user reset, and the use of the NRST signal to reset all the components of the system.

An external power-on reset can drive this pin during the start-up instead of using the internal power-on reset circuit.

The NRST pin integrates a permanent pull-up of about 100 k Ω resistor to VDDIO.

This pin has Schmitt trigger input.

6.4 ERASE Pin

The ERASE pin is used to re-initialize the Flash content and some of its NVM bits. It integrates a permanent pull-down resistor of about 15 k Ω to GND.

To eliminate any risk of erasing the Flash due to noise on the ERASE pin, it should be tied externally to GND, which prevents erasing the Flash from the application, or put in place an external low value resistor (such as 1 k Ω).

This pin is debounced by the RC oscillator to improve the glitch tolerance. When the pin is tied to high during less than 100 ms, ERASE pin is not taken into account. The pin must be tied high during more than 220 ms to perform the re-initialization of the Flash.

6.5 SDCK Pin

The SDCK pin is dedicated to the SDRAM Clock and is an output-only without pull-up. Maximum Output Frequency of this pad is 48 MHz at 3.0V and 25 MHz at 1.65V with a maximum load of 30 pF.

6.6 PIO Controller lines

All the I/O lines PA0 to PA31, PB0 to PB31, PC0 to PC23 integrate a programmable pull-up resistor. Programming of this pull-up resistor is performed independently for each I/O line through the PIO controllers.

Typical pull-up value is 100 k Ω .

All the I/O lines have schmitt trigger inputs.

6.7 I/O Lines Current Drawing

The PIO lines PA0 to PA3 are high-drive current capable. Each of these I/O lines can drive up to 16 mA permanently.

The remaining I/O lines can draw only 8 mA.

However, the total current drawn by all the I/O lines cannot exceed 300 mA.

7. Processor and Architecture

7.1 ARM7TDMI Processor

- RISC processor based on ARMv4T Von Neumann architecture
 - Runs at up to 55 MHz, providing 0.9 MIPS/MHz (core supplied with 1.8V)
- Two instruction sets
 - ARM[®] high-performance 32-bit instruction set
 - Thumb[®] high code density 16-bit instruction set
- Three-stage pipeline architecture
 - Instruction Fetch (F)
 - Instruction Decode (D)
 - Execute (E)

7.2 Debug and Test Features

- EmbeddedICE[™] (Integrated embedded in-circuit emulator)
 - Two watchpoint units
 - Test access port accessible through a JTAG protocol
 - Debug communication channel
- Debug Unit
 - Two-pin UART
 - Debug communication channel interrupt handling
 - Chip ID Register
- IEEE1149.1 JTAG Boundary-scan on all digital pins

7.3 Memory Controller

- Programmable Bus Arbiter
 - Handles requests from the ARM7TDMI and the Peripheral DMA Controller
- Address decoder provides selection signals for
 - Four internal 1 Mbyte memory areas
 - One 256-Mbyte embedded peripheral area
 - Eight external 256-Mbyte memory areas
- Abort Status Registers
 - Source, Type and all parameters of the access leading to an abort are saved
 - Facilitates debug by detection of bad pointers
- Misalignment Detector
 - Alignment checking of all data accesses
 - Abort generation in case of misalignment
- Remap Command
 - Remaps the SRAM in place of the embedded non-volatile memory
 - Allows handling of dynamic exception vectors
- 16-area Memory Protection Unit (Internal Memory and peripheral protection only)

- Individually programmable size between 1K Byte and 1M Byte
- Individually programmable protection against write and/or user access
- Peripheral protection against write and/or user access
- Embedded Flash Controller
 - Embedded Flash interface, up to three programmable wait states
 - Prefetch buffer, buffering and anticipating the 16-bit requests, reducing the required wait states
 - Key-protected program, erase and lock/unlock sequencer
 - Single command for erasing, programming and locking operations
 - Interrupt generation in case of forbidden operation

7.4 External Bus Interface

- Integrates Three External Memory Controllers:
 - Static Memory Controller
 - SDRAM Controller
 - ECC Controller
- Additional Logic for NAND Flash and CompactFlash® Support
 - NAND Flash support: 8-bit as well as 16-bit devices are supported
 - CompactFlash support: all modes (Attribute Memory, Common Memory, I/O, True IDE) are supported but the signals _IOIS16 (I/O and True IDE modes) and -ATA SEL (True IDE mode) are not handled.
- Optimized External Bus:
 - 16- or 32-bit Data Bus (32-bit Data Bus for SDRAM only)
 - Up to 23-bit Address Bus, Up to 8-Mbytes Addressable
 - Up to 8 Chip Selects, each reserved to one of the eight Memory Areas
 - Optimized pin multiplexing to reduce latencies on External Memories
- Configurable Chip Select Assignment:
 - Static Memory Controller on NCS0
 - SDRAM Controller or Static Memory Controller on NCS1
 - Static Memory Controller on NCS2, Optional CompactFlash Support
 - Static Memory Controller on NCS3, NCS5 - NCS6, Optional NAND Flash Support
 - Static Memory Controller on NCS4, Optional CompactFlash Support
 - Static Memory Controller on NCS7

7.5 Static Memory Controller

- External memory mapping, 512-Mbyte address space
- 8-, or 16-bit Data Bus
- Up to 8 Chip Select Lines
- Multiple Access Modes supported
 - Byte Write or Byte Select Lines
 - Two different Read Protocols for each Memory Bank

- Multiple device adaptability
 - Compliant with LCD Module
 - Compliant with PSRAM in synchronous operations
 - Programmable Setup Time Read/Write
 - Programmable Hold Time Read/Write
- Multiple Wait State Management
 - Programmable Wait State Generation
 - External Wait Request
 - Programmable Data Float Time

7.6 SDRAM Controller

- Numerous configurations supported
 - **2K, 4K, 8K Row Address Memory Parts**
 - **SDRAM with two or four Internal Banks**
 - **SDRAM with 16- or 32-bit Data Path**
- Programming facilities
 - **Word, half-word, byte access**
 - **Automatic page break when Memory Boundary has been reached**
 - **Multibank Ping-pong Access**
 - **Timing parameters specified by software**
 - **Automatic refresh operation, refresh rate is programmable**
- **Energy-saving capabilities**
 - **Self-refresh, and Low-power Modes supported**
- Error detection
 - **Refresh Error Interrupt**
- **SDRAM Power-up Initialization by software**
- **Latency is set to two clocks (CAS Latency of 1, 3 Not Supported)**
- **Auto Precharge Command not used**
- Mobile SDRAM supported (except for low-power extended mode and deep power-down mode)

7.7 Error Corrected Code Controller

- Tracking the accesses to a NAND Flash device by triggering on the corresponding chip select
- Single bit error correction and 2-bit Random detection.
- Automatic Hamming Code Calculation while writing
 - ECC value available in a register
- Automatic Hamming Code Calculation while reading
 - Error Report, including error flag, correctable error flag and word address being detected erroneous
 - Supports 8- or 16-bit NAND Flash devices with 512-, 1024-, 2048- or 4096-byte pages

7.8 Peripheral DMA Controller

- Handles data transfer between peripherals and memories
- Eleven channels
 - Two for each USART
 - Two for the Debug Unit
 - Two for the Serial Synchronous Controller
 - Two for the Serial Peripheral Interface
 - One for the Analog-to-digital Converter
- Low bus arbitration overhead
 - One Master Clock cycle needed for a transfer from memory to peripheral
 - Two Master Clock cycles needed for a transfer from peripheral to memory
- Next Pointer management for reducing interrupt latency requirements
- Peripheral DMA Controller (PDC) priority is as follows (from the highest priority to the lowest):

Receive	DBGU
Receive	USART0
Receive	USART1
Receive	SSC
Receive	ADC
Receive	SPI
Transmit	DBGU
Transmit	USART0
Transmit	USART1
Transmit	SSC
Transmit	SPI

8. Memories

- 512 Kbytes of Flash Memory (SAM7SE512)
 - dual plane
 - two contiguous banks of 1024 pages of 256 bytes
 - Fast access time, 30 MHz single-cycle access in Worst Case conditions
 - Page programming time: 6 ms, including page auto-erase
 - Page programming without auto-erase: 3 ms
 - Full chip erase time: 15 ms
 - 10,000 write cycles, 10-year data retention capability
 - 32 lock bits, each protecting 32 lock regions of 64 pages
 - Protection Mode to secure contents of the Flash
- 256 Kbytes of Flash Memory (SAM7SE256)
 - single plane
 - one bank of 1024 pages of 256 bytes
 - Fast access time, 30 MHz single-cycle access in Worst Case conditions
 - Page programming time: 6 ms, including page auto-erase
 - Page programming without auto-erase: 3 ms
 - Full chip erase time: 15 ms
 - 10,000 cycles, 10-year data retention capability
 - 16 lock bits, each protecting 16 lock regions of 64 pages
 - Protection Mode to secure contents of the Flash
- 32 Kbytes of Flash Memory (SAM7SE32)
 - single plane
 - one bank of 256 pages of 128 bytes
 - Fast access time, 30 MHz single-cycle access in Worst Case conditions
 - Page programming time: 6 ms, including page auto-erase
 - Page programming without auto-erase: 3 ms
 - Full chip erase time: 15 ms
 - 10,000 cycles, 10-year data retention capability
 - 8 lock bits, each protecting 8 lock regions of 32 pages
 - Protection Mode to secure contents of the Flash
- 32 Kbytes of Fast SRAM (SAM7SE512/256)
 - Single-cycle access at full speed
- 8 Kbytes of Fast SRAM (SAM7SE32)
 - Single-cycle access at full speed

Figure 8-1. SAM7SE Memory Mapping

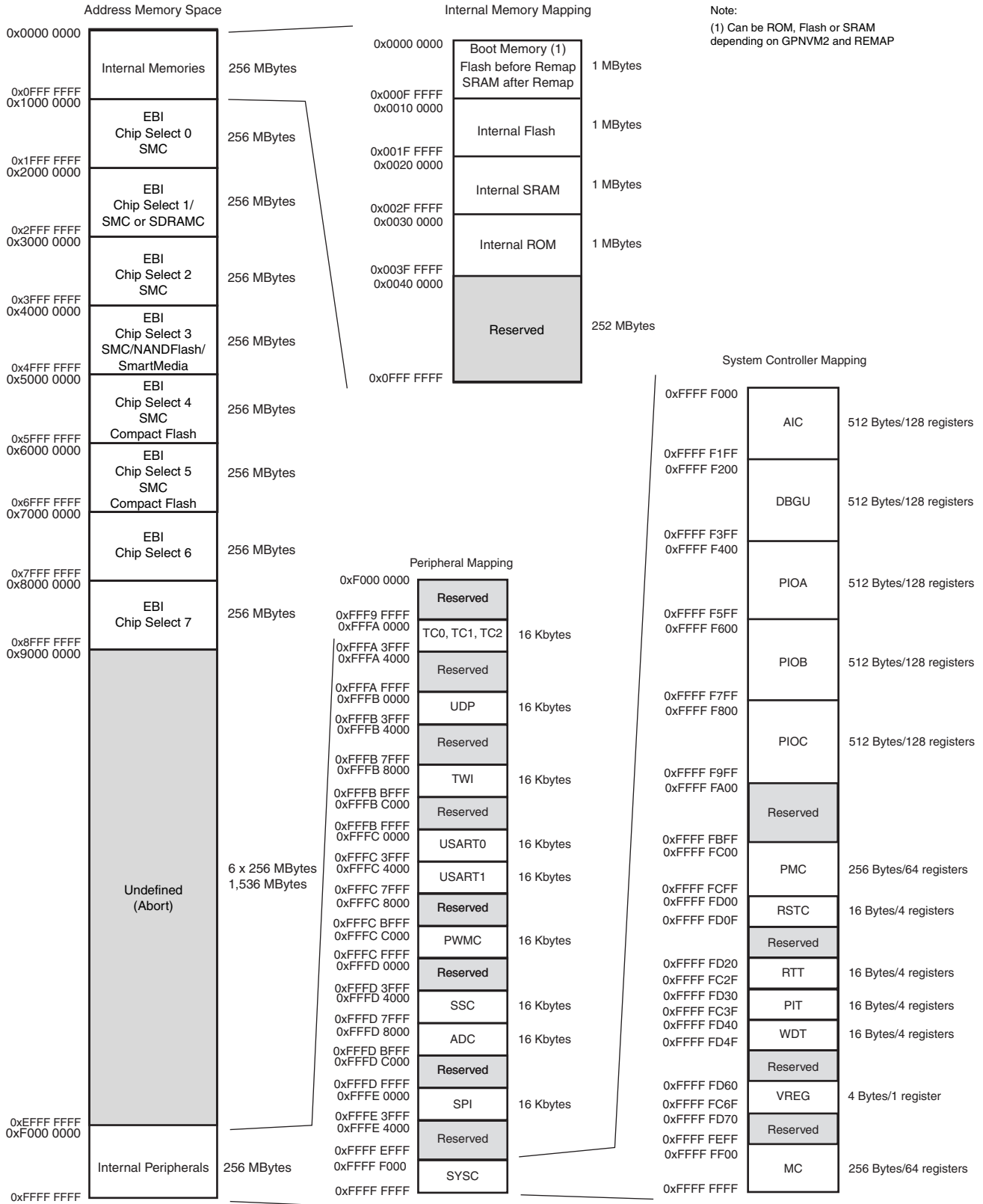

A first level of address decoding is performed by the Memory Controller, i.e., by the implementation of the Advanced System Bus (ASB) with additional features.

Decoding splits the 4G bytes of address space into 16 areas of 256M bytes. The areas 1 to 8 are directed to the EBI that associates these areas to the external chip selects NC0 to NCS7. The area 0 is reserved for the addressing of the internal memories, and a second level of decoding provides 1M byte of internal memory area. The area 15 is reserved for the peripherals and provides access to the Advanced Peripheral Bus (APB).

Other areas are unused and performing an access within them provides an abort to the master requesting such an access.

8.1 Embedded Memories

8.1.1 Internal Memories

8.1.1.1 Internal SRAM

The SAM7SE512/256 embeds a high-speed 32-Kbyte SRAM bank. The SAM7SE32 embeds a high-speed 8-Kbyte SRAM bank. After reset and until the Remap Command is performed, the SRAM is only accessible at address 0x0020 0000. After Remap, the SRAM also becomes available at address 0x0.

8.1.1.2 Internal ROM

The SAM7SE512/256/32 embeds an Internal ROM. At any time, the ROM is mapped at address 0x30 0000. The ROM contains the FFPI and the SAM-BA boot program.

8.1.1.3 Internal Flash

- The SAM7SE512 features two banks of 256 Kbytes of Flash.
- The SAM7SE256 features one bank of 256 Kbytes of Flash.
- The SAM7SE32 features one bank of 32 Kbytes of Flash.

At any time, the Flash is mapped to address 0x0010 0000.

A general purpose NVM (GPNVM) bit is used to boot either on the ROM (default) or from the Flash.

This GPNVM bit can be cleared or set respectively through the commands “Clear General-purpose NVM Bit” and “Set General-purpose NVM Bit” of the EFC User Interface.

Setting the GPNVM bit 2 selects the boot from the Flash, clearing it selects the boot from the ROM. Asserting ERASE clears the GPNVM bit 2 and thus selects the boot from the ROM by default.

Figure 8-2. Internal Memory Mapping with GPNVM Bit 2 = 0 (default)

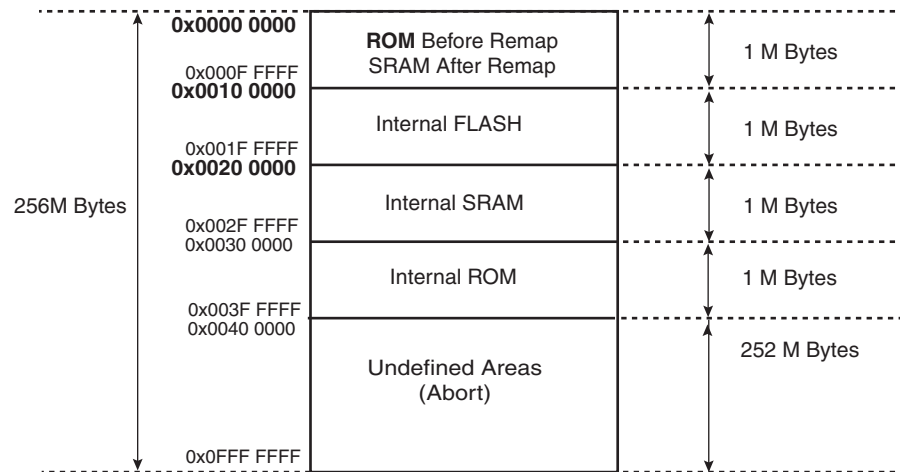
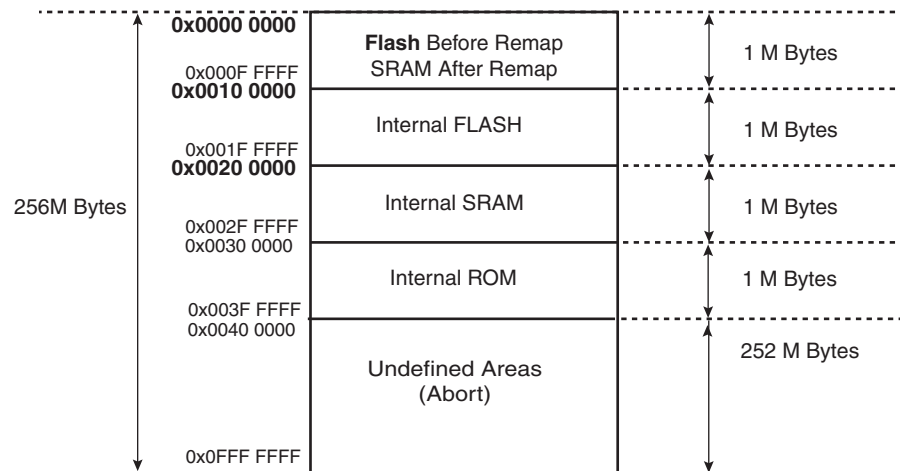

Figure 8-3. Internal Memory Mapping with GPNVM Bit 2 = 1



8.1.2 Embedded Flash

8.1.2.1 Flash Overview

The Flash of the SAM7SE512 is organized in two banks (dual plane) of 1024 pages of 256 bytes. It reads as 131,072 32-bit words.

The Flash of the SAM7SE256 is organized in 1024 pages (single plane) of 256 bytes. It reads as 65,536 32-bit words.

The Flash of the SAM7SE32 is organized in 256 pages (single plane) of 128 bytes. It reads as 8192 32-bit words.

The Flash of the SAM7SE32 contains a 128-byte write buffer, accessible through a 32-bit interface.

The Flash of the SAM7SE512/256 contains a 256-byte write buffer, accessible through a 32-bit interface.

The Flash benefits from the integration of a power reset cell and from the brownout detector. This prevents code corruption during power supply changes, even in the worst conditions.

8.1.2.2 *Embedded Flash Controller*

The Embedded Flash Controller (EFC) manages accesses performed by the masters of the system. It enables reading the Flash and writing the write buffer. It also contains a User Interface, mapped within the Memory Controller on the APB. The User Interface allows:

- programming of the access parameters of the Flash (number of wait states, timings, etc.)
- starting commands such as full erase, page erase, page program, NVM bit set, NVM bit clear, etc.
- getting the end status of the last command
- getting error status
- programming interrupts on the end of the last commands or on errors

The Embedded Flash Controller also provides a dual 32-bit Prefetch Buffer that optimizes 16-bit access to the Flash. This is particularly efficient when the processor is running in Thumb mode.

- Two EFCs (EFC0 and EFC1) are embedded in the SAM7SE512 to control each plane of 256 KBytes. Dual plane organization allows concurrent Read and Program.
- One EFC (EFC0) is embedded in the SAM7SE256 to control the single plane 256 KBytes.
- One EFC (EFC0) is embedded in the SAM7SE32 to control the single plane 32 KBytes.

8.1.2.3 *Lock Regions*

The SAM7SE512 Embedded Flash Controller manages 32 lock bits to protect 32 regions of the flash against inadvertent flash erasing or programming commands. The SAM7SE512 contains 32 lock regions and each lock region contains 64 pages of 256 bytes. Each lock region has a size of 16 Kbytes.

The SAM7SE256 Embedded Flash Controller manages 16 lock bits to protect 16 regions of the flash against inadvertent flash erasing or programming commands. The SAM7SE256 contains 16 lock regions and each lock region contains 64 pages of 256 bytes. Each lock region has a size of 16 Kbytes.

The SAM7SE32 Embedded Flash Controller manages 8 lock bits to protect 8 regions of the flash against inadvertent flash erasing or programming commands. The SAM7SE32 contains 8 lock regions and each lock region contains 32 pages of 128 bytes. Each lock region has a size of 4 Kbytes.

If a locked-region's erase or program command occurs, the command is aborted and the EFC triggers an interrupt.

The 32 (SAM7SE512), 16 (SAM7SE256) or 8 (SAM7SE32) NVM bits are software programmable through the EFC User Interface. The command "Set Lock Bit" enables the protection. The command "Clear Lock Bit" unlocks the lock region.

Asserting the ERASE pin clears the lock bits, thus unlocking the entire Flash.

8.1.2.4 *Security Bit Feature*

The SAM7SE512/256/32 features a security bit, based on a specific NVM-bit. When the security is enabled, any access to the Flash, either through the ICE interface or through the Fast Flash Programming Interface, is forbidden.

The security bit can only be enabled through the Command “Set Security Bit” of the EFC User Interface. Disabling the security bit can only be achieved by asserting the ERASE pin at 1 and after a full flash erase is performed. When the security bit is deactivated, all accesses to the flash are permitted.

It is important to note that the assertion of the ERASE pin should always be longer than 200 ms.

As the ERASE pin integrates a permanent pull-down, it can be left unconnected during normal operation. However, it is safer to connect it directly to GND for the final application.

8.1.2.5 *Non-volatile Brownout Detector Control*

Two general purpose NVM (GPNVM) bits are used for controlling the brownout detector (BOD), so that even after a power loss, the brownout detector operations remain in their state.

These two GPNVM bits can be cleared or set respectively through the commands “Clear General-purpose NVM Bit” and “Set General-purpose NVM Bit” of the EFC User Interface.

- GPNVM bit 0 is used as a brownout detector enable bit. Setting the GPNVM bit 0 enables the BOD, clearing it disables the BOD. Asserting ERASE clears the GPNVM bit 0 and thus disables the brownout detector by default.
- GPNVM bit 1 is used as a brownout reset enable signal for the reset controller. Setting the GPNVM bit 1 enables the brownout reset when a brownout is detected, Clearing the GPNVM bit 1 disables the brownout reset. Asserting ERASE disables the brownout reset by default.

8.1.2.6 *Calibration Bits*

Sixteen NVM bits are used to calibrate the brownout detector and the voltage regulator. These bits are factory configured and cannot be changed by the user. The ERASE pin has no effect on the calibration bits.

8.1.3 **Fast Flash Programming Interface**

The Fast Flash Programming Interface allows programming the device through either a serial JTAG interface or through a multiplexed fully-handshaked parallel port. It allows gang-programming with market-standard industrial programmers.

The FFPI supports read, page program, page erase, full erase, lock, unlock and protect commands.

The Fast Flash Programming Interface is enabled and the Fast Programming Mode is entered when the TST pin and the PA0 and PA1 pins are all tied high and PA2 tied to low.

- The Flash of the SAM7SE512 is organized in 2048 pages of 256 bytes (dual plane). It reads as 131,072 32-bit words.
- The Flash of the SAM7SE256 is organized in 1024 pages of 256 bytes (single plane). It reads as 65,536 32-bit words.
- The Flash of the SAM7SE32 is organized in 256 pages of 128 bytes (single plane). It reads as 32,768 32-bit words.
- The Flash of the SAM7SE512/256 contains a 256-byte write buffer, accessible through a 32-bit interface.
- The Flash of the SAM7SE32 contains a 128-byte write buffer, accessible through a 32-bit interface.

8.1.4 SAM-BA[®] Boot

The SAM-BA Boot is a default Boot Program which provides an easy way to program in-situ the on-chip Flash memory.

The SAM-BA Boot Assistant supports serial communication via the DBGU or the USB Device Port.

- Communication via the DBGU supports a wide range of crystals from 3 to 20 MHz via software auto-detection.
- Communication via the USB Device Port is limited to an 18.432 MHz crystal.

The SAM-BA Boot provides an interface with SAM-BA Graphic User Interface (GUI).

The SAM-BA Boot is in ROM and is mapped in Flash at address 0x0 when GPNVM bit 2 is set to 0.

8.2 External Memories

The external memories are accessed through the External Bus Interface.

Refer to the memory map in [Figure 8-1 on page 22](#).

9. System Controller

The System Controller manages all vital blocks of the microcontroller: interrupts, clocks, power, time, debug and reset.

The System Controller peripherals are all mapped to the highest 4 Kbytes of address space, between addresses 0xFFFF F000 and 0xFFFF FFFF.

[Figure 9-1 on page 29](#) shows the System Controller Block Diagram.

[Figure 8-1 on page 22](#) shows the mapping of the User Interface of the System Controller peripherals. Note that the Memory Controller configuration user interface is also mapped within this address space.

Figure 9-1. System Controller Block Diagram

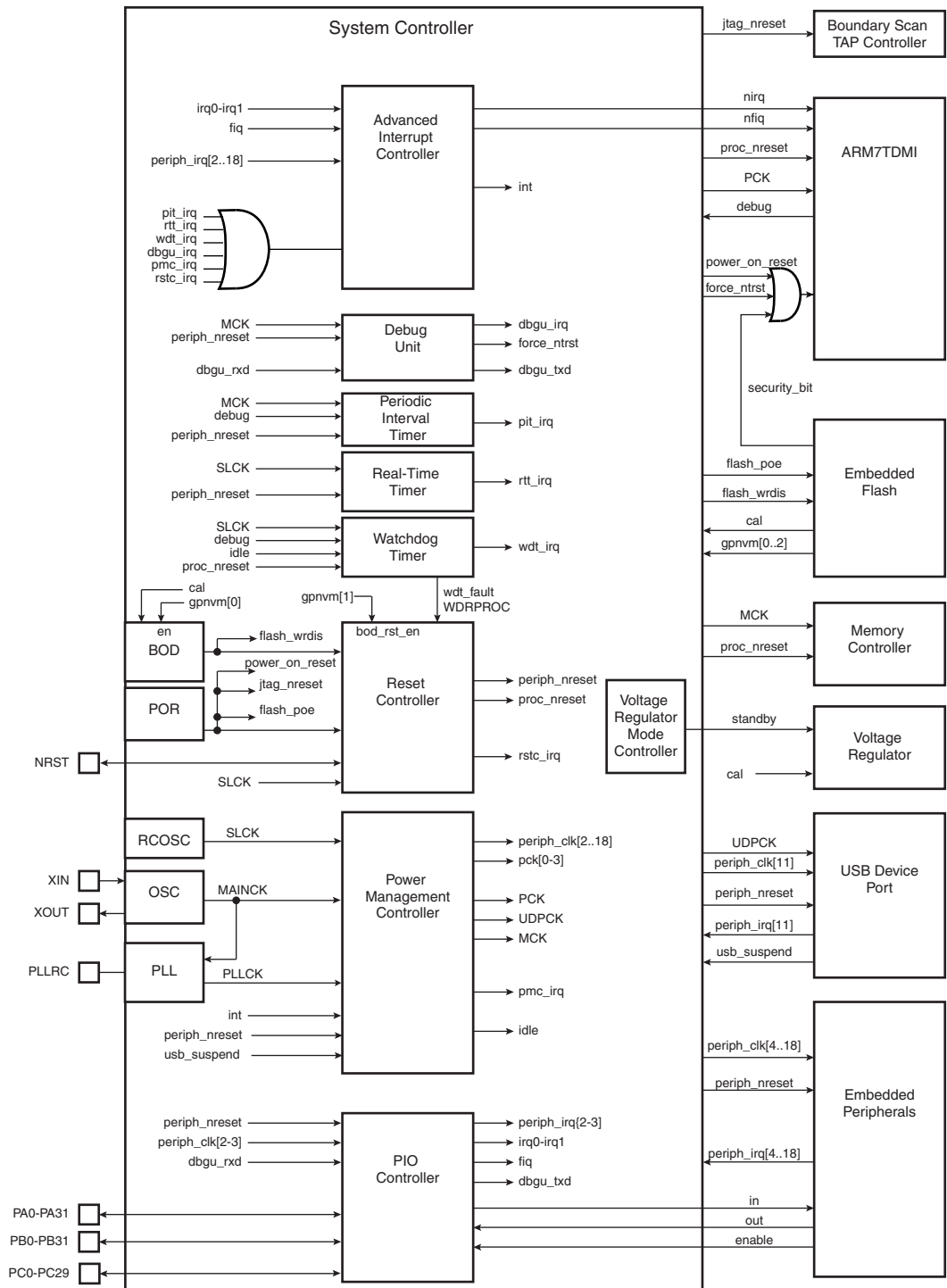

9.1 Reset Controller

- Based on one power-on reset cell and a double brownout detector
- Status of the last reset, either Power-up Reset, Software Reset, User Reset, Watchdog Reset, Brownout Reset
- Controls the internal resets and the NRST pin output
- Allows to shape a signal on the NRST line, guaranteeing that the length of the pulse meets any requirement.

9.1.1 Brownout Detector and Power On Reset

The SAM7SE512/256/32 embeds one brownout detection circuit and a power-on reset cell. The power-on reset is supplied with and monitors VDDCORE.

Both signals are provided to the Flash to prevent any code corruption during power-up or power-down sequences or if brownouts occur on the VDDCORE power supply.

The power-on reset cell has a limited-accuracy threshold at around 1.5V. Its output remains low during power-up until VDDCORE goes over this voltage level. This signal goes to the reset controller and allows a full re-initialization of the device.

The brownout detector monitors the VDDCORE and VDDFLASH levels during operation by comparing it to a fixed trigger level. It secures system operations in the most difficult environments and prevents code corruption in case of brownout on the VDDCORE or VDDFLASH.

When the brownout detector is enabled and VDDCORE decreases to a value below the trigger level (V_{bot18-} , defined as $V_{bot18} - hyst/2$), the brownout output is immediately activated.

When VDDCORE increases above the trigger level (V_{bot18+} , defined as $V_{bot18} + hyst/2$), the reset is released. The brownout detector only detects a drop if the voltage on VDDCORE stays below the threshold voltage for longer than about 1 μ s.

The VDDCORE threshold voltage has a hysteresis of about 50 mV, to ensure spike free brownout detection. The typical value of the brownout detector threshold is 1.68V with an accuracy of $\pm 2\%$ and is factory calibrated.

When the brownout detector is enabled and VDDFLASH decreases to a value below the trigger level (V_{bot33-} , defined as $V_{bot33} - hyst/2$), the brownout output is immediately activated.

When VDDFLASH increases above the trigger level (V_{bot33+} , defined as $V_{bot33} + hyst/2$), the reset is released. The brownout detector only detects a drop if the voltage on VDDCORE stays below the threshold voltage for longer than about 1 μ s.

The VDDFLASH threshold voltage has a hysteresis of about 50 mV, to ensure spike free brownout detection. The typical value of the brownout detector threshold is 2.80V with an accuracy of $\pm 3.5\%$ and is factory calibrated.

The brownout detector is low-power, as it consumes less than 20 μ A static current. However, it can be deactivated to save its static current. In this case, it consumes less than 1 μ A. The deactivation is configured through the GPNVM bit 0 of the Flash.

9.2 Clock Generator

The Clock Generator embeds one low-power RC Oscillator, one Main Oscillator and one PLL with the following characteristics:

- RC Oscillator ranges between 22 KHz and 42 KHz

- Main Oscillator frequency ranges between 3 and 20 MHz
- Main Oscillator can be bypassed
- PLL output ranges between 80 and 220 MHz

It provides SLCK, MAINCK and PLLCK.

Figure 9-2. Clock Generator Block Diagram

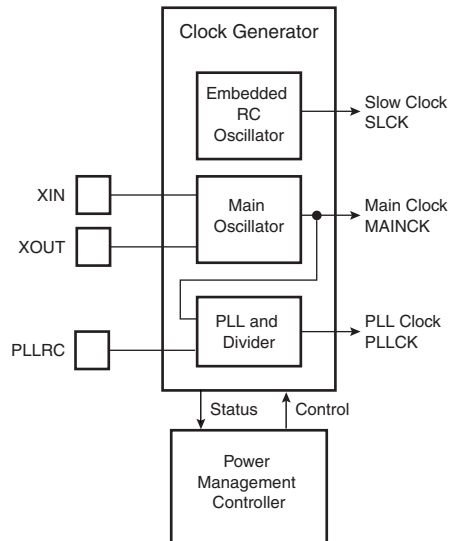

9.3 Power Management Controller

The Power Management Controller uses the Clock Generator outputs to provide:

- the Processor Clock PCK
- the Master Clock MCK
- the USB Clock UDPCK
- all the peripheral clocks, independently controllable
- three programmable clock outputs

The Master Clock (MCK) is programmable from a few hundred Hz to the maximum operating frequency of the device.

The Processor Clock (PCK) switches off when entering processor idle mode, thus allowing reduced power consumption while waiting for an interrupt.

Figure 9-3. Power Management Controller Block Diagram

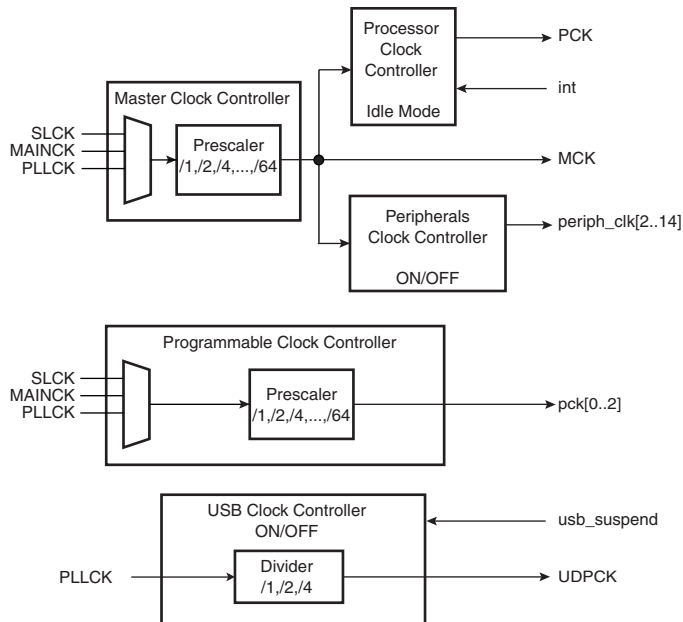

9.4 Advanced Interrupt Controller

- Controls the interrupt lines (nIRQ and nFIQ) of an ARM Processor
- Individually maskable and vectored interrupt sources
 - Source 0 is reserved for the Fast Interrupt Input (FIQ)
 - Source 1 is reserved for system peripherals (RTT, PIT, EFC, PMC, DBGU, etc.)
 - Other sources control the peripheral interrupts or external interrupts
 - Programmable edge-triggered or level-sensitive internal sources
 - Programmable positive/negative edge-triggered or high/low level-sensitive external sources
- 8-level Priority Controller
 - Drives the normal interrupt nIRQ of the processor
 - Handles priority of the interrupt sources
 - Higher priority interrupts can be served during service of lower priority interrupt
- Vectoring
 - Optimizes interrupt service routine branch and execution
 - One 32-bit vector register per interrupt source
 - Interrupt vector register reads the corresponding current interrupt vector
- Protect Mode
 - Easy debugging by preventing automatic operations
- Fast Forcing
 - Permits redirecting any interrupt source on the fast interrupt
- General Interrupt Mask
 - Provides processor synchronization on events without triggering an interrupt

9.5 Debug Unit

- Comprises:
 - One two-pin UART
 - One Interface for the Debug Communication Channel (DCC) support
 - One set of Chip ID Registers
 - One Interface providing ICE Access Prevention
- Two-pin UART
 - USART-compatible User Interface
 - Programmable Baud Rate Generator
 - Parity, Framing and Overrun Error
 - Automatic Echo, Local Loopback and Remote Loopback Channel Modes
- Debug Communication Channel Support
 - Offers visibility of COMMRX and COMMTX signals from the ARM Processor
- Chip ID Registers
 - Identification of the device revision, sizes of the embedded memories, set of peripherals
 - Chip ID is 0x272A 0A40 (VERSION 0) for SAM7SE512
 - Chip ID is 0x272A 0940 (VERSION 0) for SAM7SE256
 - Chip ID is 0x2728 0340 (VERSION 0) for SAM7SE32

9.6 Periodic Interval Timer

- 20-bit programmable counter plus 12-bit interval counter

9.7 Watchdog Timer

- 12-bit key-protected Programmable Counter running on prescaled SLCK
- Provides reset or interrupt signals to the system
- Counter may be stopped while the processor is in debug state or in idle mode

9.8 Real-time Timer

- 32-bit free-running counter with alarm running on prescaled SLCK
- Programmable 16-bit prescaler for SLCK accuracy compensation

9.9 PIO Controllers

- Three PIO Controllers. PIO A and B each control 32 I/O lines and PIO C controls 24 I/O lines.
- Fully programmable through set/clear registers
- Multiplexing of two peripheral functions per I/O line
- For each I/O line (whether assigned to a peripheral or used as general-purpose I/O)
 - Input change interrupt
 - Half a clock period glitch filter
 - Multi-drive option enables driving in open drain
 - Programmable pull-up on each I/O line
 - Pin data status register, supplies visibility of the level on the pin at any time

- Synchronous output, provides Set and Clear of several I/O lines in a single write

9.10 Voltage Regulator Controller

The purpose of this controller is to select the Power Mode of the Voltage Regulator between Normal Mode (bit 0 is cleared) or Standby Mode (bit 0 is set).

10. Peripherals

10.1 User Interface

The User Peripherals are mapped in the 256 MBytes of the address space between 0xF000 0000 and 0xFFFF EFFF. Each peripheral is allocated 16 Kbytes of address space.

A complete memory map is presented in [Figure 8-1 on page 22](#).

10.2 Peripheral Identifiers

The SAM7SE512/256/32 embeds a wide range of peripherals. [Table 10-1](#) defines the Peripheral Identifiers of the SAM7SE512/256/32. Unique peripheral identifiers are defined for both the Advanced Interrupt Controller and the Power Management Controller.

Table 10-1. Peripheral Identifiers

Peripheral ID	Peripheral Mnemonic	Peripheral Name	External Interrupt
0	AIC	Advanced Interrupt Controller	FIQ
1	SYSC ⁽¹⁾		
2	PIOA	Parallel I/O Controller A	
3	PIOB	Parallel I/O Controller B	
4	PIOC	Parallel I/O Controller C	
5	SPI	Serial Peripheral Interface 0	
6	US0	USART 0	
7	US1	USART 1	
8	SSC	Synchronous Serial Controller	
9	TWI	Two-wire Interface	
10	PWMC	PWM Controller	
11	UDP	USB Device Port	
12	TC0	Timer/Counter 0	
13	TC1	Timer/Counter 1	
14	TC2	Timer/Counter 2	
15	ADC ⁽¹⁾	Analog-to Digital Converter	
16-28	reserved		
29	AIC	Advanced Interrupt Controller	IRQ0
30	AIC	Advanced Interrupt Controller	IRQ1

Note: 1. Setting SYSC and ADC bits in the clock set/clear registers of the PMC has no effect. The System Controller is continuously clocked. The ADC clock is automatically started for the first conversion. In Sleep Mode the ADC clock is automatically stopped after each conversion.

10.3 Peripheral Multiplexing on PIO Lines

The SAM7SE512/256/32 features three PIO controllers, PIOA, PIOB and PIOC, that multiplex the I/O lines of the peripheral set.

PIO Controller A and B control 32 lines; PIO Controller C controls 24 lines. Each line can be assigned to one of two peripheral functions, A or B. Some of them can also be multiplexed with the analog inputs of the ADC Controller.

[Table 10-2 on page 37](#) defines how the I/O lines of the peripherals A and B or the analog inputs are multiplexed on the PIO Controller A, B and C. The two columns “Function” and “Comments” have been inserted for the user’s own comments; they may be used to track how pins are defined in an application.

Note that some peripheral functions that are output only may be duplicated in the table.

At reset, all I/O lines are automatically configured as input with the programmable pull-up enabled, so that the device is maintained in a static state as soon as a reset is detected.

10.4 PIO Controller A Multiplexing

Table 10-2. Multiplexing on PIO Controller A

PIO Controller A				Application Usage	
I/O Line	Peripheral A	Peripheral B	Comments	Function	Comments
PA0	PWM0	A0/NBS0	High-Drive		
PA1	PWM1	A1/NBS2	High-Drive		
PA2	PWM2	A2	High-Drive		
PA3	TWD	A3	High-Drive		
PA4	TWCK	A4			
PA5	RXD0	A5			
PA6	TXD0	A6			
PA7	RTS0	A7			
PA8	CTS0	A8			
PA9	DRXD	A9			
PA10	DTXD	A10			
PA11	NPCS0	A11			
PA12	MISO	A12			
PA13	MOSI	A13			
PA14	SPCK	A14			
PA15	TF	A15			
PA16	TK	A16/BA0			
PA17	TD	A17/BA1	AD0		
PA18	RD	NBS3/CFIOW	AD1		
PA19	RK	NCS4/CFCS0	AD2		
PA20	RF	NCS2/CFCS1	AD3		
PA21	RXD1	NCS6/CFCE2			
PA22	TXD1	NCS5/CFCE1			
PA23	SCK1	NWR1/NBS1/CFIOR			
PA24	RTS1	SDA10			
PA25	CTS1	SDCKE			
PA26	DCD1	NCS1/SDCS			
PA27	DTR1	SDWE			
PA28	DSR1	CAS			
PA29	RI1	RAS			
PA30	IRQ1	D30			
PA31	NPCS1	D31			

10.5 PIO Controller B Multiplexing

Table 10-3. Multiplexing on PIO Controller B

PIO Controller B				Application Usage	
I/O Line	Peripheral A	Peripheral B	Comments	Function	Comments
PB0	TIOA0	A0/NBS0			
PB1	TIOB0	A1/NBS2			
PB2	SCK0	A2			
PB3	NPCS3	A3			
PB4	TCLK0	A4			
PB5	NPCS3	A5			
PB6	PCK0	A6			
PB7	PWM3	A7			
PB8	ADTRG	A8			
PB9	NPCS1	A9			
PB10	NPCS2	A10			
PB11	PWM0	A11			
PB12	PWM1	A12			
PB13	PWM2	A13			
PB14	PWM3	A14			
PB15	TIOA1	A15			
PB16	TIOB1	A16/BA0			
PB17	PCK1	A17/BA1			
PB18	PCK2	D16			
PB19	FIQ	D17			
PB20	IRQ0	D18			
PB21	PCK1	D19			
PB22	NPCS3	D20			
PB23	PWM0	D21			
PB24	PWM1	D22			
PB25	PWM2	D23			
PB26	TIOA2	D24			
PB27	TIOB2	D25			
PB28	TCLK1	D26			
PB29	TCLK2	D27			
PB30	NPCS2	D28			
PB31	PCK2	D29			

10.6 PIO Controller C Multiplexing

Multiplexing on PIO Controller C

PIO Controller C				Application Usage	
I/O Line	Peripheral A	Peripheral B	Comments	Function	Comments
PC0	D0				
PC1	D1				
PC2	D2				
PC3	D3				
PC4	D4				
PC5	D5				
PC6	D6				
PC7	D7				
PC8	D8	RTS1			
PC9	D9	DTR1			
PC10	D10	PCK0			
PC11	D11	PCK1			
PC12	D12	PCK2			
PC13	D13				
PC14	D14	NPCS1			
PC15	D15	NCS3/NANDCS			
PC16	A18	NWAIT			
PC17	A19	NANDOE			
PC18	A20	NANDWE			
PC19	A21/NANDALE				
PC20	A22/REG/NANDCLE	NCS7			
PC21		NWR0/NWE/CFWE			
PC22		NRD/CFOE			
PC23	CFRNW	NCS0			

10.7 Serial Peripheral Interface

- Supports communication with external serial devices
 - Four chip selects with external decoder allow communication with up to 15 peripherals
 - Serial memories, such as DataFlash® and 3-wire EEPROMs
 - Serial peripherals, such as ADCs, DACs, LCD Controllers, CAN Controllers and Sensors
 - External co-processors
- Master or slave serial peripheral bus interface

- 8- to 16-bit programmable data length per chip select
- Programmable phase and polarity per chip select
- Programmable transfer delays per chip select, between consecutive transfers and between clock and data
- Programmable delay between consecutive transfers
- Selectable mode fault detection
- Maximum frequency at up to Master Clock

10.8 Two Wire Interface

- Master, Multi-Master and Slave Mode Operation
- Compatibility with standard two-wire serial memories
- One, two or three bytes for slave address
- Sequential read/write operations
- Bit Rate: Up to 400 Kbit/s
- General Call Supported in Slave Mode

10.9 USART

- Programmable Baud Rate Generator
- 5- to 9-bit full-duplex synchronous or asynchronous serial communications
 - 1, 1.5 or 2 stop bits in Asynchronous Mode
 - 1 or 2 stop bits in Synchronous Mode
 - Parity generation and error detection
 - Framing error detection, overrun error detection
 - MSB or LSB first
 - Optional break generation and detection
 - By 8 or by 16 over-sampling receiver frequency
 - Hardware handshaking RTS - CTS
 - Modem Signals Management DTR-DSR-DCD-RI on USART1
 - Receiver time-out and transmitter timeguard
 - Multi-drop Mode with address generation and detection
- RS485 with driver control signal
- ISO7816, T = 0 or T = 1 Protocols for interfacing with smart cards
 - NACK handling, error counter with repetition and iteration limit
- IrDA[®] modulation and demodulation
 - Communication at up to 115.2 Kbps
- Test Modes
 - Remote Loopback, Local Loopback, Automatic Echo

10.10 Serial Synchronous Controller

- Provides serial synchronous communication links used in audio and telecom applications
- Contains an independent receiver and transmitter and a common clock divider

- Offers a configurable frame sync and data length
- Receiver and transmitter can be programmed to start automatically or on detection of different event on the frame sync signal
- Receiver and transmitter include a data signal, a clock signal and a frame synchronization signal

10.11 Timer Counter

- Three 16-bit Timer Counter Channels
 - Two output compare or one input capture per channel
- Wide range of functions including:
 - Frequency measurement
 - Event counting
 - Interval measurement
 - Pulse generation
 - Delay timing
 - Pulse Width Modulation
 - Up/down capabilities
- Each channel is user-configurable and contains:
 - Three external clock inputs
 - Five internal clock inputs, as defined in [Table 10-4](#)

Table 10-4. Timer Counter Clocks Assignment

TC Clock input	Clock
TIMER_CLOCK1	MCK/2
TIMER_CLOCK2	MCK/8
TIMER_CLOCK3	MCK/32
TIMER_CLOCK4	MCK/128
TIMER_CLOCK5	MCK/1024

- Two multi-purpose input/output signals
- Two global registers that act on all three TC channels

10.12 PWM Controller

- Four channels, one 16-bit counter per channel
- Common clock generator, providing thirteen different clocks
 - One Modulo n counter providing eleven clocks
 - Two independent linear dividers working on modulo n counter outputs
- Independent channel programming
 - Independent enable/disable commands
 - Independent clock selection
 - Independent period and duty cycle, with double buffering
 - Programmable selection of the output waveform polarity
 - Programmable center or left aligned output waveform

10.13 USB Device Port

- USB V2.0 full-speed compliant, 12 Mbps per second.
- Embedded USB V2.0 full-speed transceiver
- Embedded 2688-byte dual-port RAM for endpoints
- Eight endpoints
 - Endpoint 0: 64bytes
 - Endpoint 1 and 2: 64 bytes ping-pong
 - Endpoint 3: 64 bytes
 - Endpoint 4 and 5: 512 bytes ping-pong
 - Endpoint 6 and 7: 64 bytes ping-pong
 - Ping-pong Mode (two memory banks) for Isochronous and bulk endpoints
- Suspend/resume logic
- Integrated Pull-up on DDP

10.14 Analog-to-Digital Converter

- 8-channel ADC
- 10-bit 384 Ksamples/sec. or 8-bit 583 Ksamples/sec. Successive Approximation Register ADC
- ± 2 LSB Integral Non Linearity, ± 1 LSB Differential Non Linearity
- Integrated 8-to-1 multiplexer, offering eight independent 3.3V analog inputs
- External voltage reference for better accuracy on low voltage inputs
- Individual enable and disable of each channel
- Multiple trigger sources
 - Hardware or software trigger
 - External trigger pin
 - Timer Counter 0 to 2 outputs TIOA0 to TIOA2 trigger
- Sleep Mode and conversion sequencer
 - Automatic wakeup on trigger and back to sleep mode after conversions of all enabled channels
- Each analog input shared with digital signals

11. Package Drawings

Figure 11-1. 128-lead LQFP Package Drawing

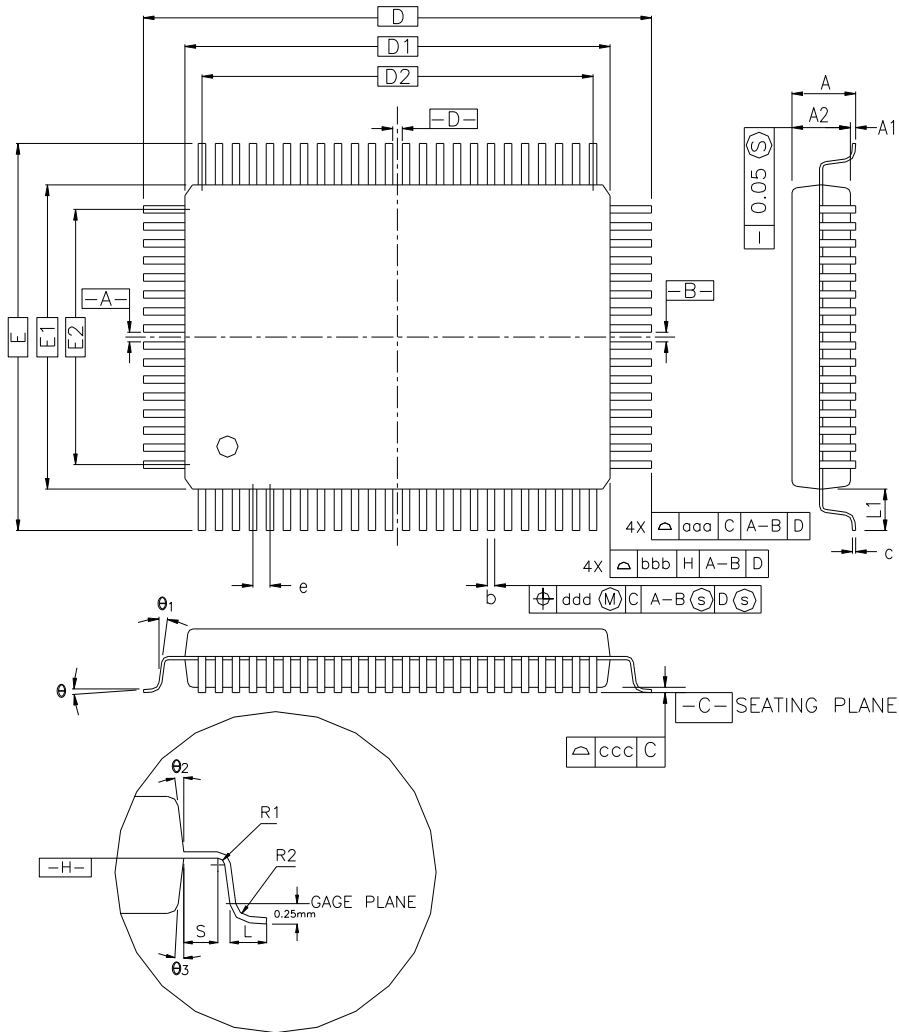

CONTROL DIMENSIONS ARE IN MILLIMETERS.

SYMBOL	MILLIMETER			INCH		
	MIN.	NOM.	MAX.	MIN.	NOM.	MAX.
A	—	—	1.60	—	—	0.063
A1	0.05	—	0.15	0.002	—	0.006
A2	1.35	1.40	1.45	0.053	0.055	0.057
D	22.00 BSC.			0.866 BSC.		
D1	20.00 BSC.			0.787 BSC.		
E	16.00 BSC.			0.630 BSC.		
E1	14.00 BSC.			0.551 BSC.		
R2	0.08	—	0.20	0.003	—	0.008
R1	0.08	—	—	0.003	—	—
θ	0°	3.5°	7°	0°	3.5°	7°
θ1	0°	—	—	0°	—	—
θ2	11°	12°	13°	11°	12°	13°
θ3	11°	12°	13°	11°	12°	13°
c	0.09	—	0.20	0.004	—	0.008
L	0.45	0.60	0.75	0.018	0.024	0.030
L1	1.00 REF			0.039 REF		
S	0.20	—	—	0.008	—	—
b	0.17	0.20	0.27	0.007	0.008	0.011
e	0.50 BSC.			0.020 BSC.		
D2	18.50			0.728		
E2	12.50			0.492		
TOLERANCES OF FORM AND POSITION						
aaa	0.20			0.008		
bbb	0.20			0.008		
ccc	0.08			0.003		
ddd	0.08			0.003		

Figure 11-2. 144-ball LFBGA Package Drawing

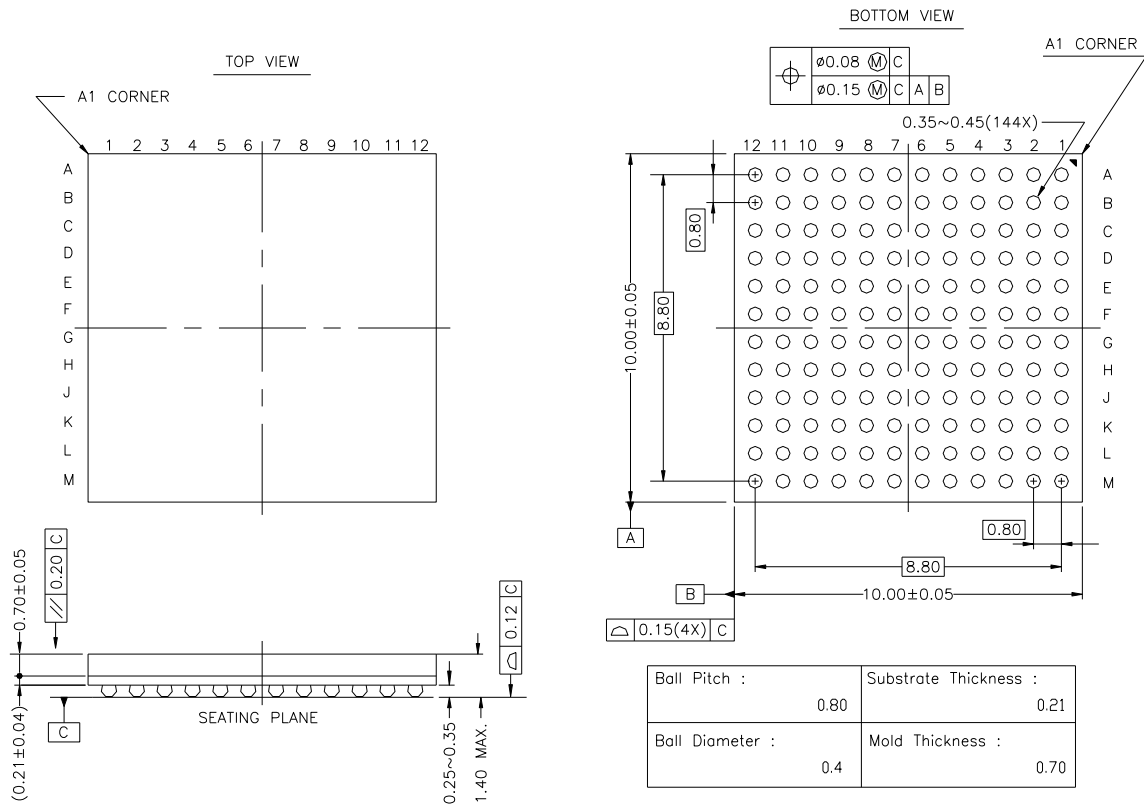

All dimensions are in mm

12. Ordering Information

Table 12-1. Ordering Information

Ordering Code	MRL	Package	Package Type	Temperature Operating Range
AT91SAM7SE512B-AU	B	LQFP128	Green	Industrial (-40· C to 85· C)
AT91SAM7SE256B-AU	B	LQFP128	Green	Industrial (-40· C to 85· C)
AT91SAM7SE32B-AU	B	LQFP128	Green	Industrial (-40· C to 85· C)
AT91SAM7SE512B-CU	B	LFBGA144	Green	Industrial (-40· C to 85· C)
AT91SAM7SE256B-CU	B	LFBGA144	Green	Industrial (-40· C to 85· C)
AT91SAM7SE32B-CU	B	LFBGA144	Green	Industrial (-40· C to 85· C)
AT91SAM7SE512-AU	A	LQFP128	Green	Industrial (-40· C to 85· C)
AT91SAM7SE256-AU	A	LQFP128	Green	Industrial (-40· C to 85· C)
AT91SAM7SE32-AU	A	LQFP128	Green	Industrial (-40· C to 85· C)
AT91SAM7SE512-CU	A	LFBGA144	Green	Industrial (-40· C to 85· C)
AT91SAM7SE256-CU	A	LFBGA144	Green	Industrial (-40· C to 85· C)
AT91SAM7SE32-CU	A	LFBGA144	Green	Industrial (-40· C to 85· C)

Revision History

Doc. Rev	Comments	Change Request Ref.
6222AS	First issue Revised Memories with condensed mapping. Added Package Outlines and 144-ball LFBGA pin and ordering information.	#2709
6222BS	Section 12. "Ordering Information" on page 45 ordering information code reference changed	#3699
6222CS	Section 6.1 "JTAG Port Pins" , Section 6.3 "Reset Pin" , Section 6.5 "SDCK Pin" , removed statement: "not 5V tolerant" Section 7.6 "SDRAM Controller" , Mobile SDRAM controller added to SDRAMC features INL and DNL updated in Section 10.14 "Analog-to-Digital Converter" "Features" on page 2, Fully Static Operation; added, up to 55 MHz at 1.8V and 85°C worst case conditions Section 7.1 "ARM7TDMI Processor" , Runs at up to 55 MHz, providing 0.9 MIPS/MHz (core supplied with 1.8V) Section 7.8 "Peripheral DMA Controller" PDC priority list added Section 7.5 "Static Memory Controller" , Multiple device adaptability includes: compliant w/PSRAM in synchronous operations.	#3826 #4005 #3924 #3833 review
6222DS	Figure 8-1 "SAM7SE Memory Mapping" Compact Flash not shown w/EBI Chip Select 5. Compact Flash is shown with EBI Chip Select 2. Section 8.1.2.1 "Flash Overview" , updated AT91SAM7SE32 ..."reads as 8192 32-bit words." Section 6. "I/O Lines Considerations" , "JTAG Port Pins", "Test Pin", "Reset Pin", "ERASE Pin" descriptions updated	4804 4512 5062
6222ES	Section 10.11 "Timer Counter" ,the TC has two output compare and one input capture per channel.	4209
6222FS	Features: "Mode for General Purpose Two-wire UART Serial Communication" added to " Debug Unit (DBGU) ". Signal Description: Table 3-1, "Signal Description List" , AD0-AD3 and AD4-AD7 comments reversed. System Controller: Figure 9-1 "System Controller Block Diagram" , 'periph_nreset' changed into 'power_on_reset' for RTT.	5846 5271 5222
6222GS	MRL B Ordering Codes added to Table 12-1, "Ordering Information" 'Product Description' changed to 'AT91SAM ARM-based Flash MCU' on the first page. 'AT91SAM' product prefix changed to 'SAM', except for Chip ID and ordering codes.	7749 rfo



Headquarters

Atmel Corporation

2325 Orchard Parkway
San Jose, CA 95131
USA
Tel: (+1) (408) 441-0311
Fax: (+1) (408) 487-2600

International

Atmel Asia Limited

Unit 01-5 & 16, 19F
BEA Tower, Millennium City 5
418 Kwun Tong Road
Kwun Tong, Kowloon
HONG KONG
Tel: (+852) 2245-6100
Fax: (+852) 2722-1369

Atmel Munich GmbH

Business Campus
Parking 4
D-85748 Garching b. Munich
GERMANY
Tel: (+49) 89-31970-0
Fax: (+49) 89-3194621

Atmel Japan

9F, Tonetsu Shinkawa Bldg.
1-24-8 Shinkawa
Chuo-ku, Tokyo 104-0033
JAPAN
Tel: (81) 3-3523-3551
Fax: (81) 3-3523-7581

Product Contact

Web Site

www.atmel.com
www.atmel.com/AT91SAM

Technical Support

AT91SAM Support
Atmel technical support

Sales Contacts

www.atmel.com/contacts/

Literature Requests

www.atmel.com/literature

Disclaimer: The information in this document is provided in connection with Atmel products. No license, express or implied, by estoppel or otherwise, to any intellectual property right is granted by this document or in connection with the sale of Atmel products. **EXCEPT AS SET FORTH IN ATMEL'S TERMS AND CONDITIONS OF SALE LOCATED ON ATMEL'S WEB SITE, ATMEL ASSUMES NO LIABILITY WHATSOEVER AND DISCLAIMS ANY EXPRESS, IMPLIED OR STATUTORY WARRANTY RELATING TO ITS PRODUCTS INCLUDING, BUT NOT LIMITED TO, THE IMPLIED WARRANTY OF MERCHANTABILITY, FITNESS FOR A PARTICULAR PURPOSE, OR NON-INFRINGEMENT. IN NO EVENT SHALL ATMEL BE LIABLE FOR ANY DIRECT, INDIRECT, CONSEQUENTIAL, PUNITIVE, SPECIAL OR INCIDENTAL DAMAGES (INCLUDING, WITHOUT LIMITATION, DAMAGES FOR LOSS OF PROFITS, BUSINESS INTERRUPTION, OR LOSS OF INFORMATION) ARISING OUT OF THE USE OR INABILITY TO USE THIS DOCUMENT, EVEN IF ATMEL HAS BEEN ADVISED OF THE POSSIBILITY OF SUCH DAMAGES.** Atmel makes no representations or warranties with respect to the accuracy or completeness of the contents of this document and reserves the right to make changes to specifications and product descriptions at any time without notice. Atmel does not make any commitment to update the information contained herein. Unless specifically provided otherwise, Atmel products are not suitable for, and shall not be used in, automotive applications. Atmel's products are not intended, authorized, or warranted for use as components in applications intended to support or sustain life.



© 2011 Atmel Corporation. All rights reserved. Atmel®, Atmel logo and combinations thereof, SAMBA®, DataFlash® and others are registered trademarks or trademarks of Atmel Corporation or its subsidiaries. ARM®, ARMPowered® logo, Cortex®, Thumb®-2 and others are registered trademarks or trademarks of ARM Ltd. Windows® and others are registered trademarks or trademarks of Microsoft Corporation in the US and/or other countries. Other terms and product names may be trademarks of others.

X-ON Electronics

Largest Supplier of Electrical and Electronic Components

Click to view similar products for [ARM Microcontrollers - MCU category](#):

Click to view products by [Microchip manufacturer](#):

Other Similar products are found below :

[R7FS3A77C2A01CLK#AC1](#) [MB96F119RBPMC-GSE1](#) [MB9BF122LPMC1-G-JNE2](#) [MB9BF122LPMC-G-JNE2](#) [MB9BF128SAPMC-GE2](#)
[MB9BF218TBGL-GE1](#) [MB9BF529TBGL-GE1](#) [26-21/R6C-AT1V2B/CT](#) [5962-8506403MQA](#) [MB9AF342MAPMC-G-JNE2](#)
[MB96F001YBPMC1-GSE1](#) [MB9BF121KPMC-G-JNE2](#) [VA10800-D000003PCA](#) [CP8547AT](#) [CY9AF156NPMC-G-JNE2](#)
[MB9BF104NAPMC-G-JNE1](#) [ADUCM410BCBZ-RL7](#) [GD32f303RGT6](#) [NHS3152UK/A1Z](#) [MK26FN2M0CAC18R](#) [EFM32TG230F32-D-QFN64](#) [EFM32TG232F32-D-QFP64](#) [EFM32TG825F32-D-BGA48](#) [MB9AFB44NBBGL-GE1](#) [MB9BF304RBPMC-G-JNE2](#)
[MB9BF416RPMC-G-JNE2](#) [MB9AF155MABGL-GE1](#) [MB9BF306RBPMC-G-JNE2](#) [MB9BF618TBGL-GE1](#) [ATSAMS70N21A-CN](#)
[MK20DX64VFT5](#) [MK50DX128CMC7](#) [MK51DN256CMD10](#) [MK51DX128CMC7](#) [MK53DX256CMD10](#) [MKL25Z32VFT4](#) [LPC1754FBD80](#)
[STM32F030K6T6TR](#) [ATSAM3N0AA-MU](#) [ATSAM3N0CA-CU](#) [ATSAM3SD8BA-MU](#) [ATSAM4LC2BA-UUR](#) [ATSAM4LC4BA-MU](#)
[ATSAM4LS2AA-MU](#) [ADuC7023BCPZ62I-R7](#) [ATSAM4LS4CA-CFU](#) [STR711FR0T6](#) [XMC1302Q040X0200ABXUMA1](#)
[STM32L431RCT6](#) [ADUCM3027BCPZ-R7](#)