Bill of Materials and Implementation of the Transceiver Base Station Board ATAB5811/12-x-B

The ATA5811/12 is part of Atmel®'s RF transceiver family dedicated to unlicensed frequency bands.

This document describes the bill of materials (BOM) required to operate the ATA5811/12, allowing use of this RF transceiver in the popular ISM bands 315/433/868 MHz.

Most of the components values are the same regardless of the frequency bands; only the matching of the antenna and the quartz crystal should take into account the frequency that is targeted.

This BOM relates to the implementation of our demo boards. The two-layer layout that is provided is recommended. Nevertheless, it is possible to use a different layout, which might require some minor change of values for optimal use.

1. Schematic and Layout

The schematic of the demo board is illustrated in [Figure 1-1 on page 2](#), and the layout is shown in [Figure 1-2 on page 3](#), [Figure 1-3 on page 3](#), [Figure 1-4 on page 4](#) and [Figure 1-5 on page 4](#).



**Transceiver
Base Station
Board
ATAB5811-x-B/
ATAB5812-x-B**

Application Note

4947A-WIRE-08/06



Figure 1-1. Schematic of the Transceiver Board

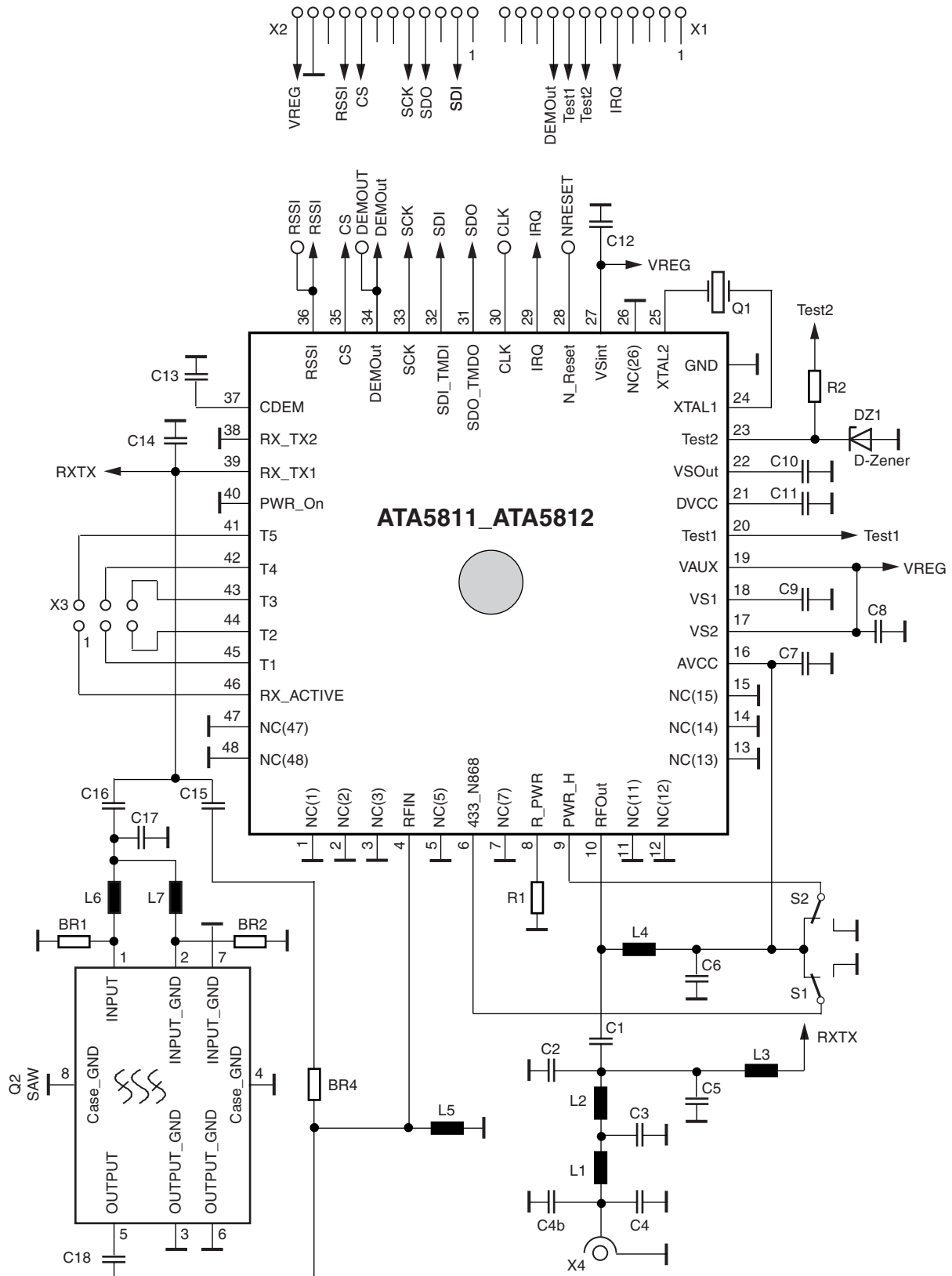

Figure 1-2. Board Layout Front Face

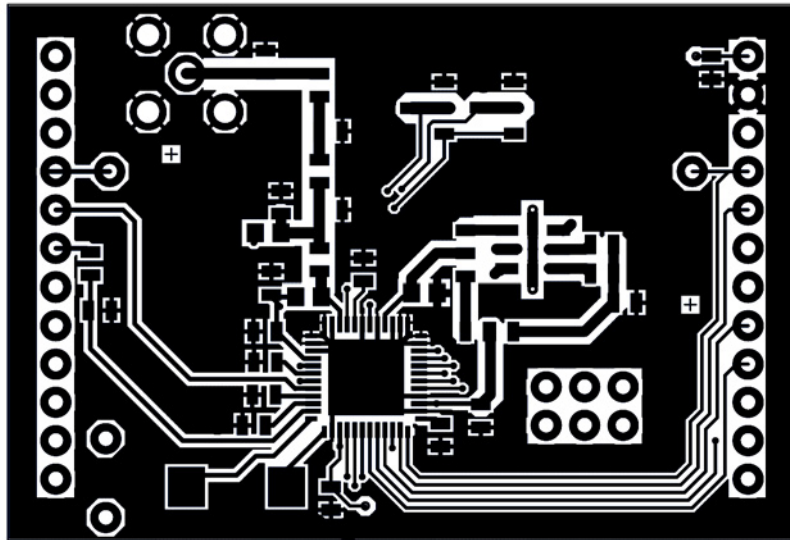

Figure 1-3. Board Layout Rear Face

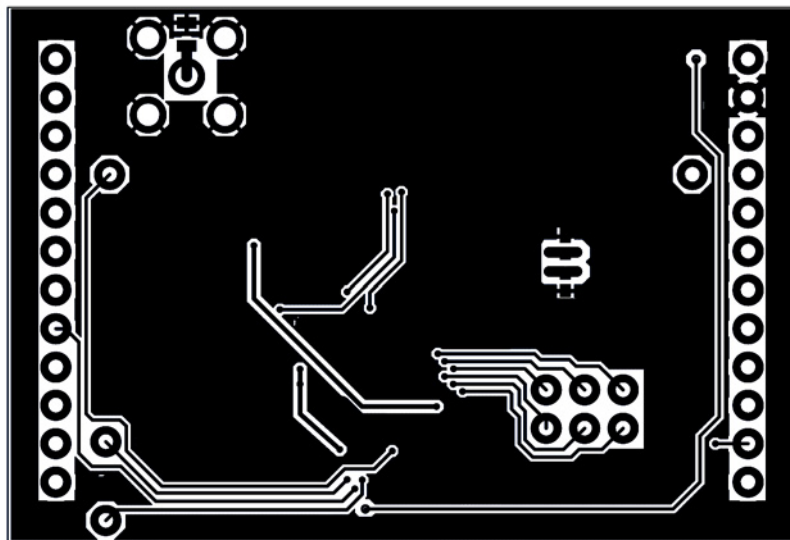

Figure 1-4. Component Placement Front Face

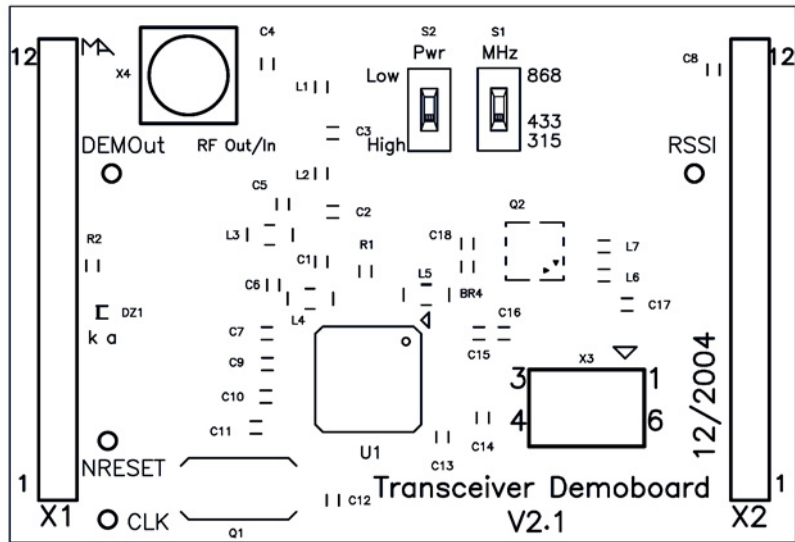
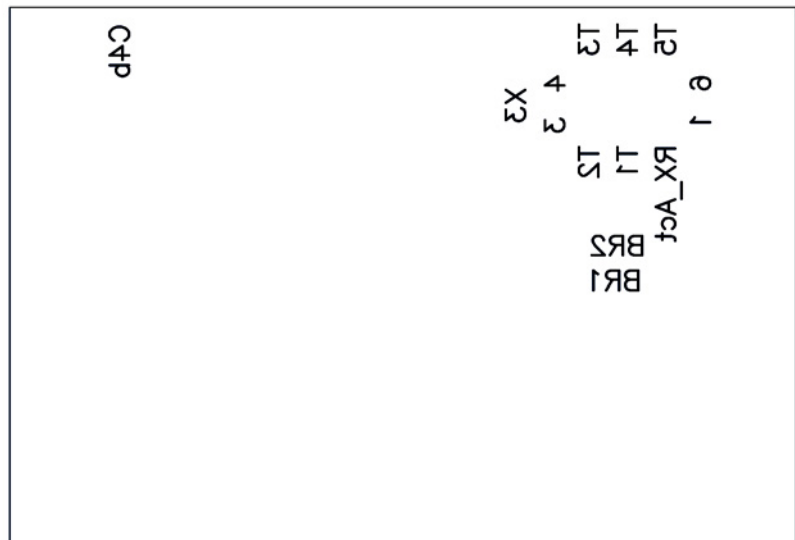

Figure 1-5. Component Placement Rear Face



2. Board Versions and Bill of Material

The transceiver base station board is available for 315 MHz, 433.92 MHz and 868.3 MHz in high power mode, that is, with an RF output power of approximately 10 dBm at 50Ω. The board ordering numbers for the different frequency versions are given in [Table 2-1](#).

Table 2-1. Board Versions

RF Frequency	Board Ordering Number
315 MHz	ATAB5812-3-B
433.92 MHz	ATAB5811-4-B
868.3 MHz	ATAB5811-8-B

Each application operating in a given frequency band must be set to correspond to [Table 2-2](#) to get the best performance from the transceiver.

Table 2-2. Components List Transceiver Demoboard ATAB5811/12-x-B V2.1

Component	Pcs	ATAB5812-3-B	ATAB5811-4-B	ATAB5811-8-B	Value	Tol. (±)	Material/Series	Housing	Manufacturer/Distributor	
U1	1		X	X	ATA5811			QFN48	Atmel	
		X			ATA5812					
Q1	1	X			12.731930 MHz		4730008074 KB101-05187	U2G CX-8045G	ACAL AVX Kyocera®	
			X		13.253110 MHz		4730008075 KB101-05189			
				X	13.411910 MHz		4730008076 KB101-05188			
C1	1			X	1.5 pF/50V	0.1 pF	C0G	Size 0603	E.g., Murata®	
			X		4.7 pF/50V					
		X			5.0 pF/50V					
C2	1			X	4.0 pF/50V	0.1 pF	C0G	Size 0603	E.g., Murata	
			X		15 pF/50V					5%
		X			18 pF/50V					
C3					Not mounted					
C4	1			X	3.0 pF/50V	0.1 pF	C0G	Size 0603	E.g., Murata	
		X	X		4.0 pF/50V					
C4b					Not mounted					
C5					Not mounted					



Table 2-2. Components List Transceiver Demoboard ATAB5811/12-x-B V2.1 (Continued)

Component	Pcs	ATAB5812-3-B	ATAB5811-4-B	ATAB5811-8-B	Value	Tol. (±)	Material/Series	Housing	Manufacturer/Distributor
C6	1	X	X	X	10 nF/ 50V	10%	X7R	Size 0603	E.g., Murata
C7	1	X	X	X	68 nF/16BV	10%	X7R	Size 0603	E.g., Murata
C8	1	X	X	X	4.7 μF/6.3V	20%	JMK107BJ475MA	Size 0603	Taiyo Yuden®
C9	1	X	X	X	2.2 μF/6.3V	10%	JMK107BJ225KA	Size 0603	Taiyo Yuden
C10	1	X	X	X	68 nF/16V	10%	X7R	Size 0603	E.g., Murata
C11	1	X	X	X	2.2 μF/6.3V	10%	JMK107BJ225KA	Size 0603	Taiyo Yuden
C12	1	X	X	X	68 nF/16V	10%	X7R	Size 0603	E.g., Murata
C13	1	X	X	X	15 nF/50V	10%	X7R	Size 0603	E.g., Murata
C14					Not mounted				
C15	1	X	X	X	1.8 pF/50V	0.1 pF	C0G	Size 0603	E.g., Murata
C16					Not mounted				
C17					Not mounted				
C18					Not mounted				
R1	1	X		X	15 kΩ/0.1W	5%		Size 0603	E.g., Vishay®
			X		18 kΩ/0.1W				
R2	1	X	X	X	2.2 kΩ/0.1W	5%		Size 0603	E.g., Vishay
BR1					Not mounted				
BR2					Not mounted				
BR4	1	X	X	X	0Ω			Size 0603	E.g., Vishay
DZ1	1	X	X	X	3.9V		BZX284C3V9	SOD110	Philips®
L1	1	X	X	X	0Ω			Size 0603	E.g., Vishay
L2	1			X	10 nH		744 786 11	Size 0603	Würth®
			X		18 nH		744 786 118		
		X			27 nH		744 786 121		
L3	1	X	X	X	0Ω			Size 0603	E.g., Vishay
L4	1			X	15 nH		744 760 115	Size 0805	Würth
			X		30 nH		744 768 130		
		X			56 nH		744 760 15		
L5	1			X	5.6 nH		744 768 056	Size 0805	Würth
			X		27 nH		744 768 127		
		X			56 nH		744 760 15		

Table 2-2. Components List Transceiver Demoboard ATAB5811/12-x-B V2.1 (Continued)

Component	Pcs	ATAB5812-3-B	ATAB5811-4-B	ATAB5811-8-B	Value	Tol. (±)	Material/Series	Housing	Manufacturer/ Distributor
L6					Not mounted				
L7					Not mounted				
Q2					Not mounted				
X1	1	X	X	X	Row connector		800-10-012-10-001	12 pins/ 0.1 in. pitch	CAB
X2	1	X	X	X	Row connector		800-10-012-10-001	12 pins/ 0.1 in. pitch	CAB
X3	1	X	X	X	6-pin header		1002-1171-006	2×3 pin	CAB
X4	1	X	X	X	SMB connector		R114 426 000		Radial [®]
S1-VCC	1	X	X		0Ω			Size 0603	E.g., Vishay
S1-GND	1			X	0Ω			Size 0603	E.g., Vishay
S2-VCC	1	X	X	X	0Ω			Size 0603	E.g., Vishay
S2-GND	1				0Ω			Size 0603	E.g., Vishay
PCB	1	X	X	X	Transceiver demoboard V2.1		FR4	Thickness 1.5 mm	



Atmel Corporation

2325 Orchard Parkway
San Jose, CA 95131, USA
Tel: 1(408) 441-0311
Fax: 1(408) 487-2600

Regional Headquarters

Europe

Atmel Sarl
Route des Arsenaux 41
Case Postale 80
CH-1705 Fribourg
Switzerland
Tel: (41) 26-426-5555
Fax: (41) 26-426-5500

Asia

Room 1219
Chinachem Golden Plaza
77 Mody Road Tsimshatsui
East Kowloon
Hong Kong
Tel: (852) 2721-9778
Fax: (852) 2722-1369

Japan

9F, Tonetsu Shinkawa Bldg.
1-24-8 Shinkawa
Chuo-ku, Tokyo 104-0033
Japan
Tel: (81) 3-3523-3551
Fax: (81) 3-3523-7581

Atmel Operations

Memory

2325 Orchard Parkway
San Jose, CA 95131, USA
Tel: 1(408) 441-0311
Fax: 1(408) 436-4314

Microcontrollers

2325 Orchard Parkway
San Jose, CA 95131, USA
Tel: 1(408) 441-0311
Fax: 1(408) 436-4314

La Chantrerie
BP 70602
44306 Nantes Cedex 3, France
Tel: (33) 2-40-18-18-18
Fax: (33) 2-40-18-19-60

ASIC/ASSP/Smart Cards

Zone Industrielle
13106 Rousset Cedex, France
Tel: (33) 4-42-53-60-00
Fax: (33) 4-42-53-60-01

1150 East Cheyenne Mtn. Blvd.
Colorado Springs, CO 80906, USA
Tel: 1(719) 576-3300
Fax: 1(719) 540-1759

Scottish Enterprise Technology Park
Maxwell Building
East Kilbride G75 0QR, Scotland
Tel: (44) 1355-803-000
Fax: (44) 1355-242-743

RF/Automotive

Theresienstrasse 2
Postfach 3535
74025 Heilbronn, Germany
Tel: (49) 71-31-67-0
Fax: (49) 71-31-67-2340

1150 East Cheyenne Mtn. Blvd.
Colorado Springs, CO 80906, USA
Tel: 1(719) 576-3300
Fax: 1(719) 540-1759

Biometrics/Imaging/Hi-Rel MPU/ High-Speed Converters/RF Datacom

Avenue de Rochepleine
BP 123
38521 Saint-Egreve Cedex, France
Tel: (33) 4-76-58-30-00
Fax: (33) 4-76-58-34-80

Literature Requests

www.atmel.com/literature

Disclaimer: The information in this document is provided in connection with Atmel products. No license, express or implied, by estoppel or otherwise, to any intellectual property right is granted by this document or in connection with the sale of Atmel products. **EXCEPT AS SET FORTH IN ATMEL'S TERMS AND CONDITIONS OF SALE LOCATED ON ATMEL'S WEB SITE, ATMEL ASSUMES NO LIABILITY WHATSOEVER AND DISCLAIMS ANY EXPRESS, IMPLIED OR STATUTORY WARRANTY RELATING TO ITS PRODUCTS INCLUDING, BUT NOT LIMITED TO, THE IMPLIED WARRANTY OF MERCHANTABILITY, FITNESS FOR A PARTICULAR PURPOSE, OR NON-INFRINGEMENT. IN NO EVENT SHALL ATMEL BE LIABLE FOR ANY DIRECT, INDIRECT, CONSEQUENTIAL, PUNITIVE, SPECIAL OR INCIDENTAL DAMAGES (INCLUDING, WITHOUT LIMITATION, DAMAGES FOR LOSS OF PROFITS, BUSINESS INTERRUPTION, OR LOSS OF INFORMATION) ARISING OUT OF THE USE OR INABILITY TO USE THIS DOCUMENT, EVEN IF ATMEL HAS BEEN ADVISED OF THE POSSIBILITY OF SUCH DAMAGES.** Atmel makes no representations or warranties with respect to the accuracy or completeness of the contents of this document and reserves the right to make changes to specifications and product descriptions at any time without notice. Atmel does not make any commitment to update the information contained herein. Unless specifically provided otherwise, Atmel products are not suitable for, and shall not be used in, automotive applications. Atmel's products are not intended, authorized, or warranted for use as components in applications intended to support or sustain life.

© 2006 Atmel Corporation. All rights reserved. Atmel®, logo and combinations thereof, Everywhere You Are® and others are registered trademarks or trademarks of Atmel Corporation or its subsidiaries. Other terms and product names may be trademarks of others.

X-ON Electronics

Largest Supplier of Electrical and Electronic Components

Click to view similar products for [Mobile Development Tools](#) category:

Click to view products by [Microchip](#) manufacturer:

Other Similar products are found below :

[MIKROE-2535](#) [1946](#) [TEL0089](#) [EVK-N211-02B](#) [1963](#) [2687](#) [2691](#) [E206XT-B](#) [MIKROE-3350](#) [MIKROE-3351](#) [MIKROE-3757](#) [MIKROE-3885](#) [MIKROE-1298](#) [MIKROE-1375](#) [MIKROE-1428](#) [MIKROE-1720](#) [MIKROE-3294](#) [MIKROE-497](#) [VZ120Q-STK](#) [XK3-C-A2-T-UB](#)
[109030001](#) [109030002](#) [CEL-13120](#) [CEL-14997](#) [EVK-R510M8S-0](#) [EVK-R510S-0](#)