AT02876: Atmel REB212BSMA Hardware User Manual

Atmel MCU Wireless

Introduction

This manual describes the REB212BSMA radio extender board, demonstrating the high performance at ultra-low power consumption of the Atmel® AT86RF212B radio transceiver.

Features

- High-performance 700/800/900MHz, RF-CMOS AT86RF212B radio transceiver targeted for ZigBee®, IEEE® 802.15.4, 6LoWPAN, and ISM Applications
 - 121dB link budget
 - Ultra-low current consumption
 - Ultra-low supply voltage (1.8V to 3.6V)
- RF reference design and high-performance evaluation platform
- Interfaces to several of the Atmel microcontroller development platforms
- Board information EEPROM
 - MAC address
 - Board identification, features, and serial number
 - Crystal calibration values

1 Introduction

This manual describes the REB212BSMA radio extender board, demonstrating the high performance at ultra-low power consumption of the Atmel AT86RF212B radio transceiver. Detailed information is given in the individual sections about the board functionality, the board interfaces, and the board design.

The REB212BSMA connects directly to the REB controller base board (REB-CBB) [2], or can be used as an RF interface in combination with one of the Atmel microcontroller development platforms. The REB212BSMA together with a microcontroller forms a fully functional wireless node.

Figure 1-1. REB212BSMA Radio Extender Board

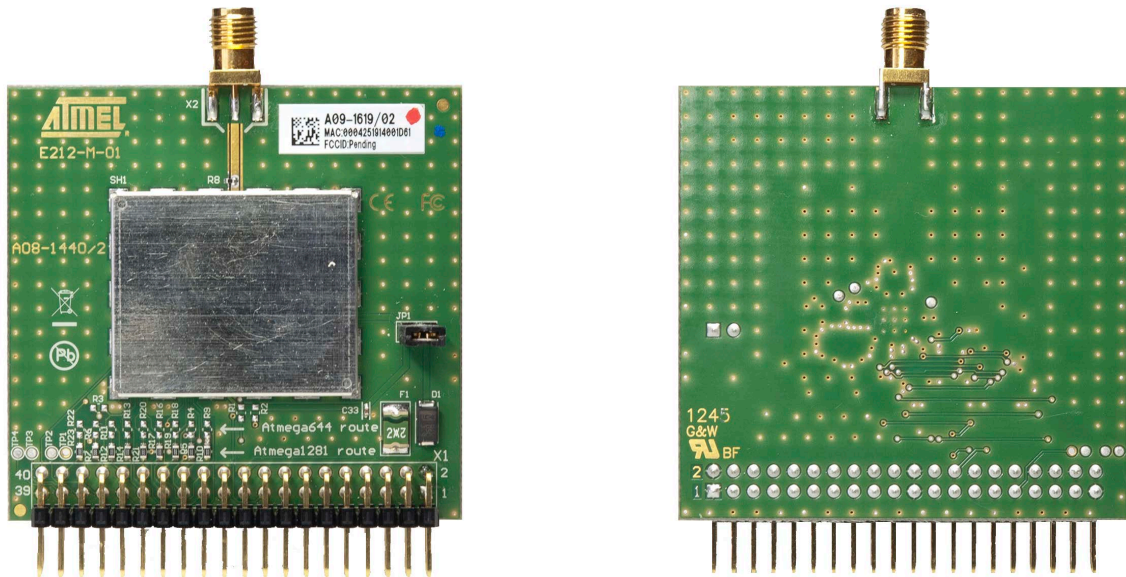

2 Disclaimer

Typical values contained in this application note are based on simulations and testing of individual examples. Any information about third-party materials or parts was included in this document for convenience. The vendor may have changed the information that has been published. Check the individual vendor information for the latest changes.

3 Overview

The radio extender board is assembled with an Atmel AT86RF212B radio transceiver [1] and equipped with an SMA connector for an external whip antenna. External antennas can be connected to the SMA ports as well as RF measurement equipment for performance evaluation of the radio transceiver.

The radio extender board was designed to interface to the Atmel microcontroller development or evaluation platforms (for example, Atmel STK[®]500). The microcontroller platform in combination with the REB provides an ideal way to:

- Evaluate the outstanding radio transceiver performance, such as the excellent receiver sensitivity achieved at ultra-low current consumption
- Test the radio transceiver's comprehensive hardware support of the IEEE 802.15.4-2011 standard
- Test the radio transceiver's enhanced feature set, which includes MAC hardware acceleration, AES encryption and high data rate modes

Figure 3-1 shows a development and evaluation setup using the REB controller base board (REB-CBB) in combination with the REB212BSMA radio extender board; via SMA connector which is assembled with quarter wave whip antenna.

Figure 3-1. The REB212BSMA Connected to a REB-CBB



4 Functional Description

The block diagram of the REB212BSMA radio extender board is shown in Figure 4-1. The power supply pins and all digital I/Os of the radio transceiver are routed to the 2 × 20-pin expansion connector to interface to a power supply and a microcontroller.

Board-specific information such as board identifier, MAC address and production calibration values are stored in an ID EEPROM. The SPI bus of the EEPROM is shared with the radio transceiver interface.

Figure 4-1. REB212BSMA Block Diagram

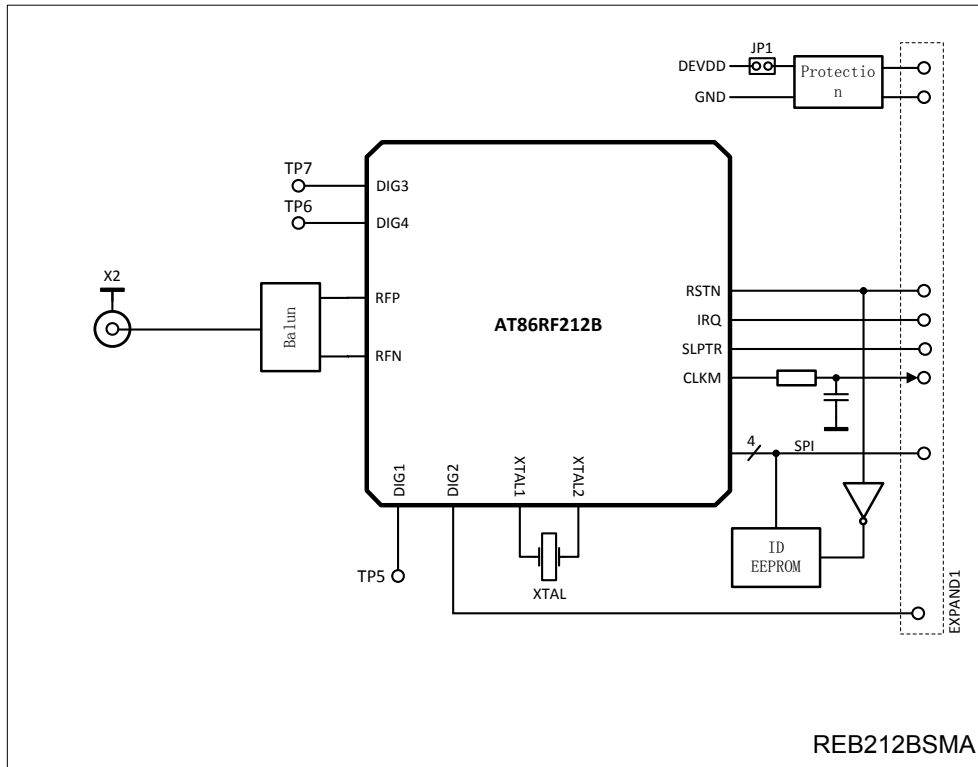

4.1 Interface Connector

The REB212BSMA is equipped with a 2 × 20-pin, 100mil, expansion connector, X1. The pin assignment enables a direct interface to the REB-CBB [2]. Further, the interface connects to the Atmel STK500/501 microcontroller development platform to enable support for various Atmel 8-bit AVR® microcontrollers.

The REB212BSMA is preconfigured to interface to an STK501 with an Atmel ATmega1281 or a REB-CBB with an Atmel ATmega 256A3 respectively.

To operate the REB212BSMA with an Atmel ATmega644 on STK500, the 0Ω resistors R10 through R18 must be removed and re-installed on the board manually as resistors R20 through R28 (see [Appendix A](#)).

Other microcontroller development platforms need to be interfaced using a special adapter board.

4.1.1 Atmel ATmega1281 Configuration

[Table 4-1](#) lists the pin assignment of the ATmega1281 configuration (shipping default).

Table 4-1. Default Expansion Connector Mapping (ATmega1281 Configuration)

Pin#	Function	Pin#	Function
1	GND	2	GND
3	n.c.	4	n.c.
5	n.c.	6	n.c.
7	n.c.	8	n.c.
9	n.c.	10	n.c.
11	n.c.	12	n.c.

Pin#	Function	Pin#	Function
13	n.c.	14	n.c.
15	n.c.	16	n.c.
17	n.c., optionally XT1 (MCLK) ⁽¹⁾	18	n.c.
19	V _{CC}	20	V _{CC}
21	GND	22	GND
23	PB7 (open)	24	PB6 (open)
25	PB5 (RSTN)	26	PB4 (SLPTR)
27	PB3 (MISO)	28	PB2 (MOSI)
29	PB1 (SCLK)	30	PB0 (SEL)
31	PD7 (TP1)	32	PD6 (MCLK)
33	PD5 (TP2)	34	PD4 (DIG2)
35	PD3 (TP3)	36	PD2 (open)
37	PD1 (TP4)	38	PD0 (IRQ)
39	GND	40	EE#WP (write protect EEPROM)

Note: 1. Possible by retrofitting a 0R assembly.

4.1.2 Atmel ATmega644 Configuration

Table 4-2 lists the pin assignment of the ATmega644 configuration. It is enabled by re-assembling R10 through R23 to their alternate locations.

Table 4-2. Expansion Connector Mapping when Assembled for ATmega644

Pin#	Function	Pin#	Function
1	GND	2	GND
3	n.c.	4	n.c.
5	n.c.	6	n.c.
7	n.c.	8	n.c.
9	n.c.	10	n.c.
11	n.c.	12	n.c.
13	n.c.	14	n.c.
15	n.c.	16	n.c.
17	n.c., optionally XT1 (MCLK) ⁽¹⁾	18	n.c.
19	V _{CC}	20	V _{CC}
21	GND	22	GND
23	PB7 (SCLK)	24	PB6 (MISO)
25	PB5 (MOSI)	26	PB4 (SEL)
27	PB3 (open)	28	PB2 (RSTN)
29	PB1 (MCLK)	30	PB0 (open)

Pin#	Function	Pin#	Function
31	PD7 (SLPTR)	32	PD6 (DIG2)
33	PD5 (TP2)	34	PD4 (open)
35	PD3 (TP3)	36	PD2 (IRQ)
37	PD1 (TP4)	38	PD0 (open)
39	GND	40	EE#WP (write protect EEPROM)

Note: 1. Possible by retrofitting a 0R assembly.

4.2 ID EEPROM

To identify the board type by software, an identification (ID) EEPROM (U5) is populated. Information about the board, the node MAC address and production calibration values are stored here. A serial EEPROM AT25010B [3] with 128 × 8-bit organization and SPI bus is used because of its small package and low-voltage and low-power operation.

The SPI bus is shared between the EEPROM and the transceiver. The select signal for each SPI slave (EEPROM, radio transceiver) is decoded with the reset line of the transceiver, RSTN. Therefore, the EEPROM is addressed when the radio transceiver is held in reset (RSTN = 0; see Figure 4-2).

Figure 4-2. EEPROM Access Decoding Logic (Atmel ATmega1281 Configuration)

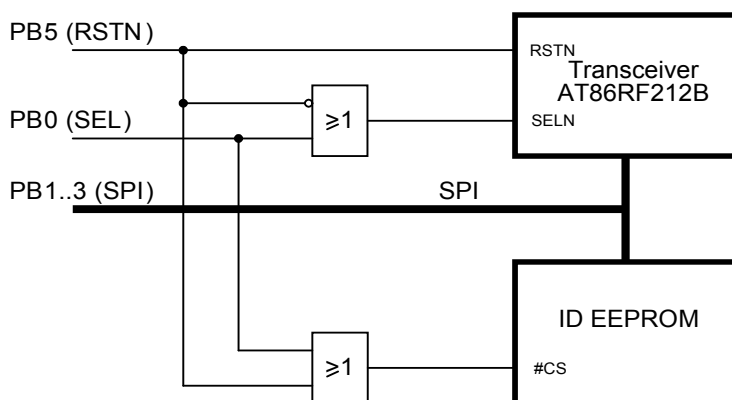

The EEPROM data is written during board production testing. A unique serial number, the MAC address, and calibration values are stored. These can be used to optimize system performance. Table 4-3 shows a detailed description of the EEPROM data structure.

Table 4-3. ID EEPROM Mapping

Address	Name	Type	Description
0x00	MAC address	uint64	MAC address for the 802.15.4 node, little endian byte order
0x08	Serial number	uint64	Board serial number, little endian byte order
0x10	Board family	uint8	Internal board family identifier
0x11	Revision	uint8[3]	Board revision number ##.##.##

Address	Name	Type	Description
0x14	Feature	uint8	Board features, coded into seven bits 7 Reserved 6 Reserved 5 External LNA 4 External PA 3 Reserved 2 Diversity 1 Antenna 0 SMA connector
0x15	Cal OSC 16MHz	uint8	XTAL calibration value, register XTAL_TRIM
0x16	Cal RC 3.6V	uint8	Atmel ATmega1281 internal RC oscillator calibration value @ 3.6V, register OSCCAL
0x17	Cal RC 2.0V	uint8	Atmel ATmega1281 internal RC oscillator calibration value @ 2.0V, register OSCCAL
0x18	Antenna gain	int8	Antenna gain [resolution 1/10dBi]. For example, 15 will indicate a gain of 1.5dBi. The values 00h and FFh are per definition invalid. Zero or -0.1dBi has to be indicated as 01h or FEh
0x20	Board name	char[30]	Textual board description
0x3E	CRC	uint16	16-bit CRC checksum, standard ITU-T generator polynomial $G16(x) = x^{16} + x^{12} + x^5 + 1$

Example: EEPROM dump.

```

0000 D0 63 17 FF FF 25 04 00 DC 25 00 00 4E 00 00 00 .c...%...%..N...
0010 00 05 00 03 02 00 86 86 00 FF FF FF FF FF FF FF .....
0020 52 61 64 69 6F 45 78 74 65 6E 64 65 72 32 31 32 RadioExtender212
0030 42 53 4D 41 00 00 00 00 00 00 00 00 00 00 2B D5 BSMA.....+.
0040 FF FF FF FF FF FF FF FF FF FF FF FF FF FF FF FF .....
0050 FF FF FF FF FF FF FF FF FF FF FF FF FF FF FF FF .....
0060 FF FF FF FF FF FF FF FF FF FF FF FF FF FF FF FF .....
0070 FF FF FF FF FF FF FF FF FF FF FF FF FF FF FF FF .....

```

4.3 Supply Current Sensing

A jumper, JP1, is placed in the supply voltage trace to offer an easy way for current sensing. The current consumption of all circuitry connected to the supply domains DEVDD/EVDD such as AT86RF212B and AT25010B can be measured by connecting an ampere meter instead of the jumper cap JP1, see [Figure 4-3](#).

The power supply pins of the radio transceiver are protected against overvoltage and reverse polarity at the X1 connector pins (net CVTG, net DGND) using a Zener diode, D1, and a thermal fuse, F1, (see [Appendix A](#)). This is required because the Atmel STK500 will provide 5V as default voltage, and the board can also be mounted with reverse polarity.

Depending on the actual supply voltage, the diode D1 can consume several milliamperes. This has to be considered when the current consumption of the whole system is measured. In such a case, D1 should be removed from the board.

To achieve the best RF performance, the analog (EVDD) and digital (DEVDD) supply are separated from each other by a CLC PI-filter.

All components connected to nets DEVDD/EVDD contribute to the total current consumption.

While in radio transceiver SLEEP state, most of the supply current is drawn by the 1M Ω pull-up resistor R21 and the EEPROM standby current.

Figure 4-3. Power Supply Routing

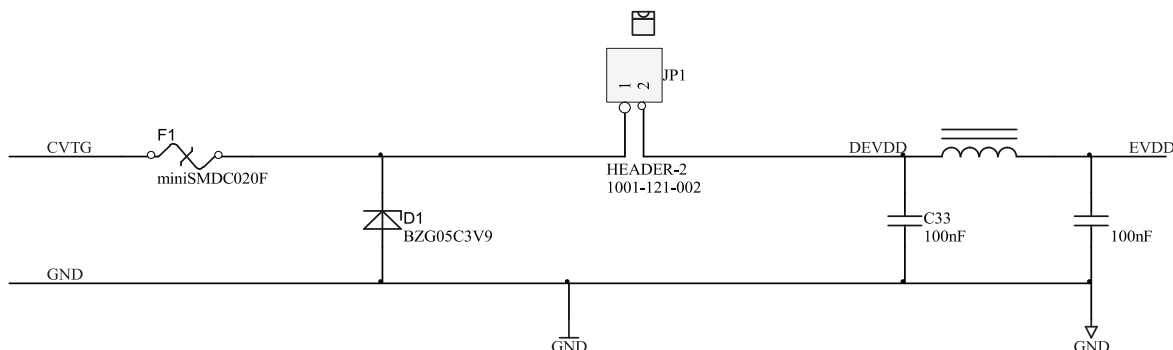

4.4 Radio Transceiver Reference Clock

The integrated radio transceiver is clocked by a 16MHz reference crystal, Q1. Operating the node according to IEEE 802.15.4 [4], the reference frequency must not exceed a deviation of ± 40 ppm. The absolute frequency is determined by the external load capacitance of the crystal, which depends on the crystal type and is given in its datasheet.

The radio transceiver reference crystal, Q1, shall be isolated from fast switching digital signals and surrounded by a grounded guard trace to minimize disturbances of the oscillation. Detailed layout considerations can be found in Section 5.2.

The REB212BSMA uses a Siward SX4025 crystal with two load capacitors of 10pF each. To compensate for fabrication and environment variations, the frequency can be further tuned using the radio transceiver register XOSC_CTRL (0x12), refer to [1]. The REB production test guarantees a tolerance of within +20ppm and -5ppm. The correction value, to be applied to TRX register XOSC_CTRL (0x12), is stored in the ID EEPROM, see Section 4.2.

The reference frequency is also available at pin CLKM of the radio transceiver and, depending on the related register setting; it is divided by an internal prescaler. The CLKM signal is filtered by a low-pass filter to reduce harmonic emissions within the 868 / 915MHz ISM band. The filter is designed to provide a stable 1MHz clock signal with correct logic level to a microcontroller pin with sufficiently suppressed harmonics. Usage of CLKM frequencies above 1MHz requires a re-design of R25 and C40. In case of RC cut-off frequency adjustments, depending on the specific load and signal routing conditions, one may observe performance degradation within affected IEEE channels.

Channel 4 (912MHz) is affected by the following harmonics: 57×16 MHz or 114×8 MHz.

By default, CLKM is routed to a microcontroller timer input; check the individual configuration resistors in the schematic drawing (see Appendix A.1). To connect CLKM to the microcontroller main clock input, assemble R3 with a 0 Ω resistor.

4.5 RF Section

The Atmel AT86RF212B radio transceiver incorporates all RF and base band critical components, necessary to transmit and receive signals according to IEEE 802.15.4 or proprietary ISM data rates.

The balun B1 performs the differential to single-ended conversion of the RF signal to connect the AT86RF212B to the SMA connector X2.

To estimate the effective output power for the SMA connector reference plane, insertion losses of the balun and the transmission line have to be taken into account. Therefore, the SMA connector output power can be up to 1.5dB below the AT86RF212B datasheet value, according to specification of the balun. Insertion loss data for the individual components can be obtained from associated datasheets. Please check the part reference inside the BOM in Appendix A.3.

5 PCB Layout Description

This section describes critical layout details to be carefully considered during a PCB design. The PCB design requires taking care of the following topics:

- Create a solid ground plane as a stable reference for the transceiver, the antenna and the transmission lines. The PCB has to be considered as a part of the antenna; it interacts with the radiated electromagnetic wave
- Isolate digital noise from the antenna and the radio transceiver to achieve optimum range and RF performance
- Isolate digital noise from the 16MHz reference crystal to achieve optimum transmitter and receiver performance
- Reduce any kind of spurious emissions below the limits set by the individual regulatory organizations

The REB212BSMA PCB design further demonstrates a low-cost, two-layer PCB solution without the need of an inner ground plane.

5.1 Balanced RF Pin Fan Out

Figure 5-1. Board Layout – RF Pin Fan Out

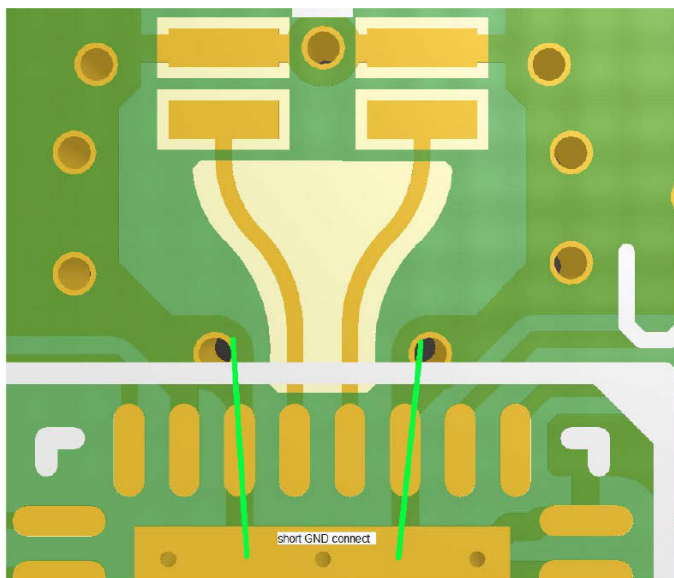

The Atmel AT86RF212B antenna port should be connected to a 100Ω load with a small series inductance of app. 3nH . This is achieved with the connection fan out in between the IC pins and the filter balun combination B1. The trace width is kept small at 0.15mm for a length of approximately 2.5mm . The REB212BSMA is a two-layer FR4 board with a thickness of 1.5mm . Therefore, the distributed capacitance between top and bottom is low, and transmission lines are rather inductive.

The distance between balun and transceiver also allows GND vias for pin 3 and pin 6 of the AT86RF212B. The GND connection in a low distance has a small parasitic inductance and is therefore desirable for the RF port.

5.2 Crystal Routing

The reference crystal PCB area requires optimization to minimize external interference and to keep any radiation of 16MHz harmonics low.

Since the board design incorporates a shield, the crystal housing has been tied hard to ground. This method will minimize the influence of external impairments such as burst and surge.

To prevent crosstalk, the crystal is encircled by a ring of ground traces and vias. Special care has to be taken in the area between the IRQ line and the crystal. Depending on the configuration, the interrupt may be activated during a frame receive. Crosstalk into the crystal lines would increase the phase noise and therefore reduce the signal to noise ratio.

Figure 5-2. Board Layout – Crystal Routing

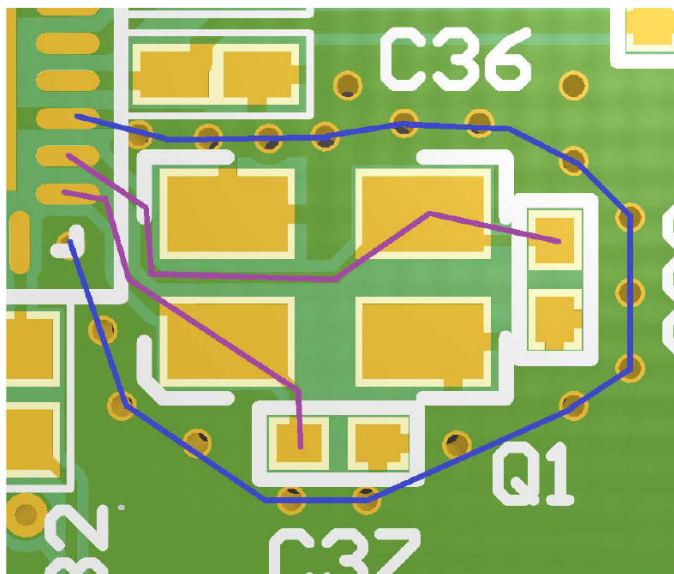

The reference crystal and its load capacitors C37/38 form the resonator circuit. These capacitors are to be placed close to the crystal. The ground connection in between the capacitors should be a solid copper area right underneath the crystal, including the housing contacts.

5.3 Transceiver Analog GND Routing

With the Atmel AT86RF212B, consider pins 3, 6, 27, 30, 31, and 32 as analog ground pins. Pin 7 is an exception and can be connected to the central paddle like the other analog ground pins.

Analog ground pins are to be routed to the paddle underneath the IC. The trace width has to be similar to the pad width when connecting the pads, and increase, if possible, in some distance from the pad. This measure will decrease the parasitic inductance as far as possible.

Each ground pin should be connected to the bottom plane with at least one via. Move the vias as close to the IC as possible. It is always desired to integrate the single-pin ground connections into polygon structures after a short distance. Top, bottom, and, on multilayer boards, the inner ground planes, should be tied together with a grid of vias. When ground loops are smaller than one tenth of the wavelength, it is safe to consider this as a solid piece of metal.

Figure 5-3. Board Layout – Transceiver GND Routing

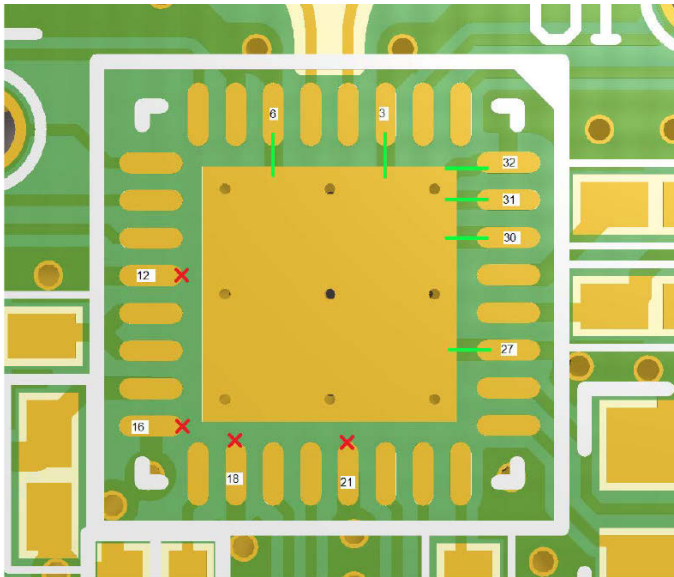

The soldering technology used allows the placement of small vias (0.15mm drill) within the ground paddle underneath the chip. During reflow soldering, the vias get filled with solder, having a positive effect on the connection cross section. The small drill size keeps solder losses within an acceptable limit. During the soldering process vias should be open on the bottom side to allow enclosed air to expand.

5.4 Digital GND Routing and Shielding

With the Atmel AT86RF212B, consider pins 12, 16, 18, and 21 as digital ground pins.

Digital ground pins are not directly connected to the center paddle. They may carry digital noise from I/O pad cells or other digital processing units within the chip.

In case of a direct paddle connection, impedances of the paddle ground vias could cause a small voltage drop for this noise and may result in an increased noise level transferred to the analog domain.

There is a number of pro's and con's when it comes to the shielding topic. The major con's are:

- Cost of the shield
- Manufacturing effort
- Inaccessibility for test and repair

The number of pro's might be longer but the cost argument is often very strong. However, the reasons to add the shield for this reference design are:

- Shield is required for a certification in Japan
- Shield is recommended for FCC certification in North America
- Increased performance

Besides the function to provide supply ground to the individual parts, the ground plane has to be considered as a counterpart for the antenna. Such an antenna base plate is required to achieve full antenna performance. It has to be a continuous, sustained metal plate for that purpose. The shield, covering the electronic section will help to form this antenna base plate.

For that reason, any unused surface should be filled with a copper plane and connected to the other ground side using sufficient through-hole contacts. Larger copper areas should also be connected to the other side layer with a grid of vias. This will form kind of a RF sealing for the PCB material. Any wave propagation in between the copper layers across the PCB will become impossible. This way, for an external electromagnetic field, the board will behave like a coherent piece of metal.

When a trace is cutting the plane on one side, the design should contain vias along this trace to bridge the interrupted ground on the other side. Place vias especially close to corners and necks to connect loose polygon ends.

The pads where the shield is mounted also need some attention. The shield has to be integrated in the ground planes. Vias, in a short distance to the pads, will ensure a low impedance connection and also close the FR4 substrate as mentioned above.

6 Mechanical Description

The REB212BSMA is manufactured using a low-cost, two-layer printed circuit board. All components and connectors are mounted on the top side of the board. The format was defined to fit the EXPAND1 connector on the Atmel AVR STK500/STK501 microcontroller evaluation board. The upright position was chosen for best antenna performance.

Figure 6-1. Mechanical Dimensions

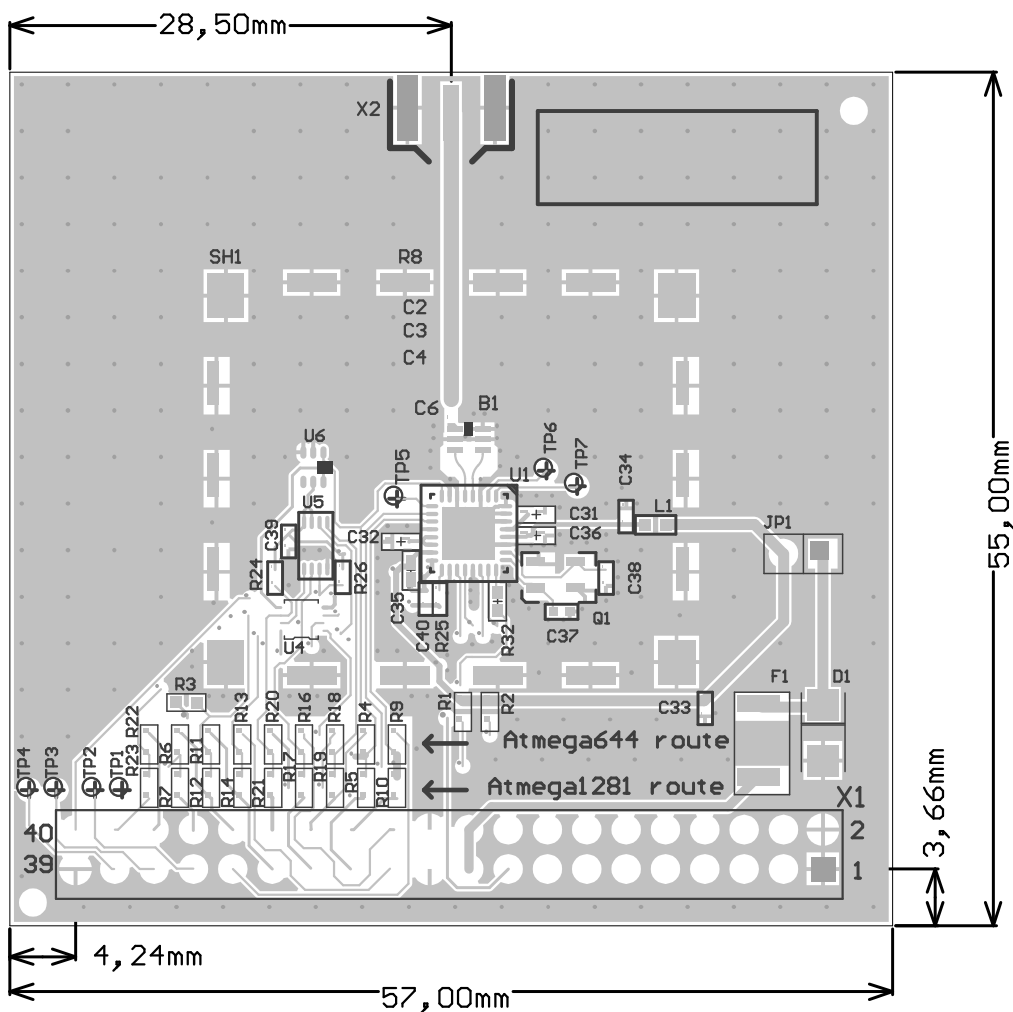

7 Electrical Characteristics

7.1 Absolute Maximum Ratings

Stresses beyond the values listed in [Table 7-1](#) may cause permanent damage to the board. This is a stress rating only and functional operation of the device at these or any other conditions beyond those indicated in the operational sections of this manual are not implied. Exposure to absolute maximum rating conditions for extended periods may affect device reliability. For more details about these parameters, refer to individual datasheets of the components used.

Table 7-1. Absolute Maximum Ratings

Storage temperature.....	-40 to +85 °C
Supply voltage.....	-0.3 to +3.6 V
Ext IO pin voltage.....	-0.3 to V _{CC} +0.3 V
Supply current from batteries.....	-0.5 A
Charge current ⁽¹⁾	0 A

(1) Keep power switch off or remove battery from REB-CBB when external power is supplied.

7.2 Recommended Operating Range

No.	Parameter	Condition	Minimum	Typical	Maximum	Units
	Operating temperature range		-20		+70	°C
	Supply voltage (V _{CC})	Plain REB-CBB	1.6	3.0	3.6	V
		REB plugged on REB-CBB	1.8	3.0	3.6	
		Serial flash access in usage	2.3	3.0	3.6	

7.3 Current Consumption

No.	Parameter	Condition	Minimum	Typical	Maximum	Units
	Supply current	Transceiver SLEEP		3 ⁽¹⁾		µA
		Transceiver TRX_OFF, CLKM switched off (CLKM_CTRL=0)		0.5		mA
		RX_ON		9.2		
		BUSY_TX ⁽²⁾		25		

- Notes: 1. Board EEPROM standby current.
2. Modulation = OQPSK-250, T_X output power = +10dBm.

8 References

- [1] AT86RF212B; Low Power, 700/800/900 MHz Transceiver for ZigBee, IEEE 802.15.4, 6LoWPAN, and ISM Applications; Datasheet; Rev. 42002A–MCU Wireless–04/12; Atmel Corporation.
- [2] AVR2042: REB Controller Base Board – Hardware User Guide; Application Note; Rev. 8334A-AVR-08/10; Atmel Corporation.
- [3] AT25010B; SPI Serial EEPROM; Datasheet; Rev. 8707CJ SEEPR 6/11; Atmel Corporation.
- [4] IEEE Std 802.15.4™-2006: Wireless Medium Access Control (MAC) and Physical Layer (PHY) Specifications for Low-Rate Wireless Personal Area Networks (LR-WPANs).
- [5] FCC Code of Federal Register (CFR); Part 47; Section 15.35, Section 15.205, Section 15.209, Section 15.232, Section 15.247, and Section 15.249. United States.
- [6] ETSI EN 300 328, Electromagnetic Compatibility and Radio Spectrum Matters (ERM); Wideband Transmission Systems; Data transmission equipment operating in the 2.4GHz ISM band and using spread spectrum modulation techniques; Part 1-3.
- [7] ARIB STD-T66, Second Generation Low Power Data Communication System/Wireless LAN System 1999.12.14 (H11.12.14) Version 1.0.

9 Abbreviations

AES	Advanced Encryption Standard
CBB	Controller Base Board
MAC	Median Access Control
PCB	Printed Circuit Board
REB	Radio Extender Board
RF	Radio frequency
SMA	Sub-miniature-A (coaxial RF connector)
SPI	Serial Peripheral Interface

Appendix A PCB Design Data

A.1 Schematic

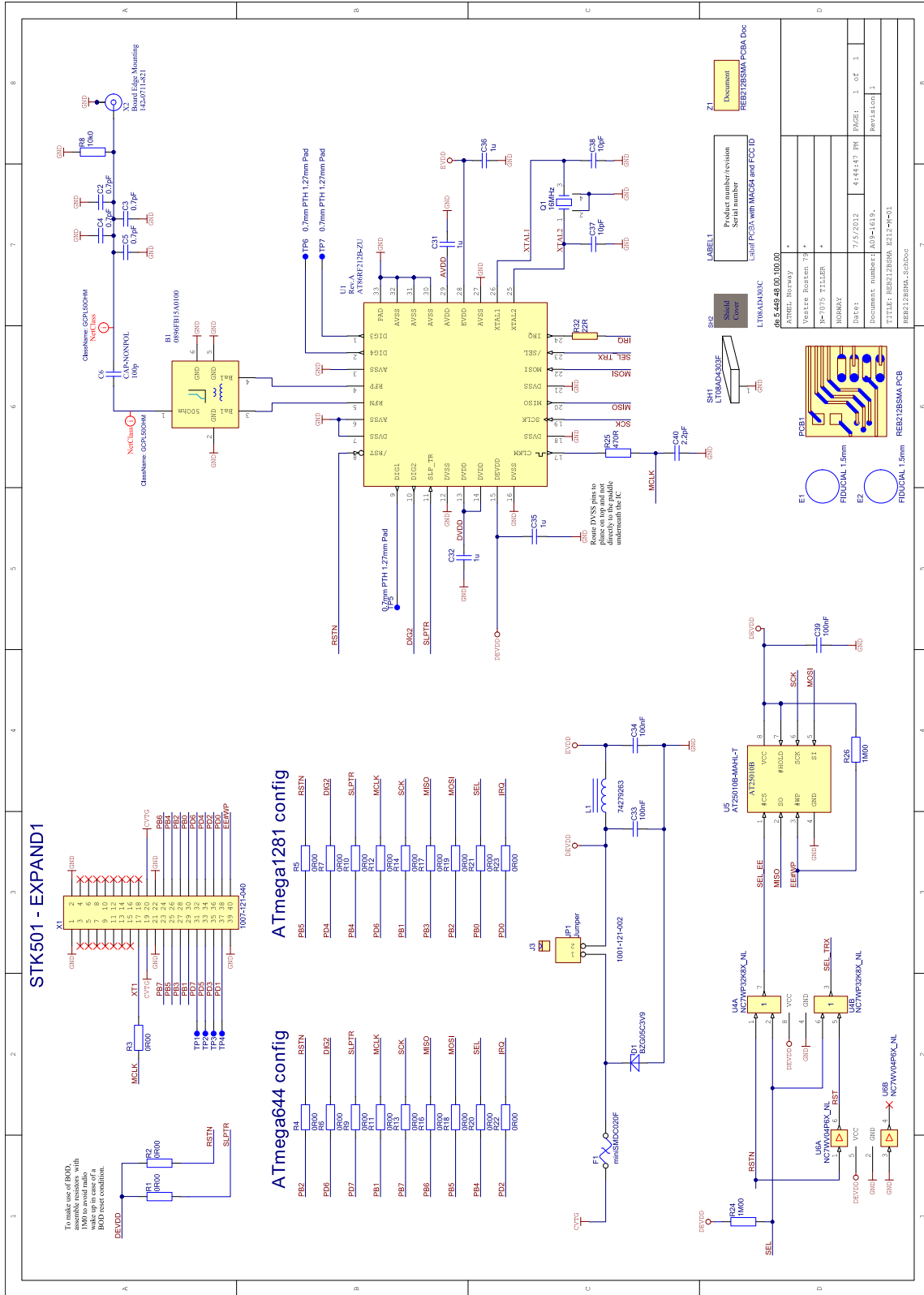

A.2 Assembly Drawing

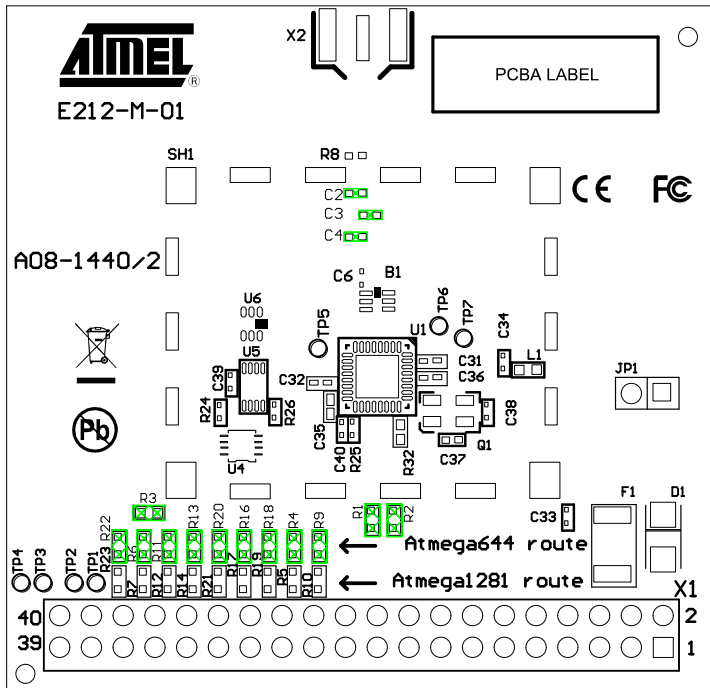

A.3 Bill of Materials

Qty.	Designator	Description	MPN	Manufacturer	Comment
1	B1	868/900MHz FilterBalun, SMD 1.25x2.0mm	0896FB15A0100	Johanson Technology	0896FB15A0100
4	C31, C32, C35, C36	Ceramic capacitor, SMD 0402, X5R, 6.3V, ±10%	C0402C105K9PAC	Kemet	1µF
3	C33, C34, C39	Ceramic capacitor, SMD 0402, X7R, 16V, ±10%	GRM155R71C104KA88D	Murata	100nF
2	C37, C38	Ceramic capacitor, SMD 0402, NP0, 50V, ±5%	ECJ0EC1H100D	Panasonic	10pF
1	C40	Ceramic capacitor, SMD 0402, NP0, 50V, ±0.25pF	GRM1555C1H2R2CZ01D	Murata	2.2pF
1	C6	Ceramic capacitor, SMD 0402, NP0, 50V, ±10% Ceramic capacitor, SMD 0402, C0G, 16V, ±5%	GRM1555C1H101JZ01D	Murata	100pF
1	D1	3V9/3W SMD Zener, SMA	BZG05C3V9	Vishay	BZG05C3V9
1	F1	PolySwitch resettable fuse 0.2A, 30V	miniSMDC020F	Raychem	miniSMDC020F
1	J3	Jumper cap for 2.54mm pin header	3300096	CAB	Jumper
1	JP1	Pin header 1x2, 2.54mm THM	1001-121-002	CAB	1001-121-002
1	L1	SMD-Ferrite 220Ω, 100MHz 0603 size	74279263	Würth Elektronik	74279263

Qty.	Designator	Description	MPN	Manufacturer	Comment
1	Q1	16MHz SX-4025, 4 x 2.5mm SMD 10ppm	XTL551150NLE-16.0MHz-9.0R	SIWARD	16MHz
9	R10, R12, R14, R17, R19, R21, R23, R5, R7	Thick film resistor, SMD 0603, 1/10W, 1%	RC1608J000CS	Samsung	0R00
2	R24, R26	Thick film resistor, SMD 0402, 1/16W, 1%	RC1005F1005CS	Samsung	1M00
1	R25	Thick film resistor, SMD 0402, 1/16W, 1%	RC1005F 4700CS	Samsung	470R
1	R32	Thick film resistor, SMD 0402, 1/16W, 1%	RC100SF22R0CS	Samsung	22R
1	R8	Thick film resistor, SMD 0402, 1/16W, 1%	RC1005F1002CS	Samsung	10k0
1	SH1	EMI Shield Frame 25x30x3mm	LT08AD4303F	Laird Technologies	LT08AD4303F
1	SH2	EMI Shield Cover 25.6x30.6x2mm	LT08AD4303C	Laird Technologies	LT08AD4303C
1	U1	Low Power 700/800/900MHz transceiver for IEEE 802.15.4, ZigBee, 6LoWPAN, and ISM applications	AT86RF212B-ZU	ATMEL	AT86RF212B-ZU
1	U4	Dual 2-Input OR gate, ULP, NC7WP32K8X, US-8	NC7WP32K8X_NL	Fairchild	NC7WP32K8X_NL
1	U5	1kbit Serial EEPROM, AT25010B-MAHL-T, 1.8-5V, Ultra Thin UDFN-8	AT25010B-MAHL-T	Adesto Technologies	AT25010B-MAHL-T
1	U6	Dual Inverter ULP-A, NC7WV04P6X_NL, SC70-6	NC7WV04P6X_NL	Fairchild	NC7WV04P6X_NL
1	X1	2x20 pin header, right angle, 2.54mm pitch, through-hole	1007-121-040	CAB	1007-121-040
1	X2	End Launch Jack Receptacle, Round Contact	142-0711-821	EMERSON	142-0711-821

Appendix B Radio Certification

The REB212BSMA, mounted on a REB controller base board (REB-CBB), has received regulatory approvals for modular devices in the United States and European countries.

B.1 United States (FCC)

B.1.1 Compliance Statement (Part 15.19)

The ATREB212BSMA-EK is certified as Limited modular transmitter with FCC ID VW4A091619. The device complies with Part 15 of the FCC rules. To fulfill FCC Certification requirements, an Original Equipment Manufacturer (OEM) must comply with the following regulations:

- The modular transmitter must be labeled with its own FCC ID number, and, if the FCC ID is not visible when the module is installed inside another device, the outside of the device into which the module is installed must also display a label referring to the enclosed module
- This exterior label can use wording such as the following. Any similar wording that expresses the same meaning may be used

Contains FCC-ID: VW4A091619

This device complies with Part 15 of the FCC Rules. Operation is subject to the following two conditions: (1) this device may not cause harmful interference, and (2) this device must accept any interference received, including interference that may cause undesired operation.

Use in portable exposure conditions (FCC 2.1093) requires separate equipment authorization. Modifications not expressly approved by this company could void the user's authority to operate this equipment (FCC Section 15.21).

B.1.2 Compliance Statement (Part 15.105(b))

This equipment has been tested and found to comply with the limits for a Class B digital device, pursuant to Part 15 of the FCC Rules. These limits are designed to provide reasonable protection against harmful interference in a residential installation. This equipment generates uses and can radiate radio frequency energy and, if not installed and used in accordance with the instructions, may cause harmful interference to radio communications. However, there is no guarantee that interference will not occur in a particular installation. If this equipment does cause harmful interference to radio or television reception, which can be determined by turning the equipment off and on, the user is encouraged to try to correct the interference by one or more of the following measures:

- Reorient or relocate the receiving antenna
- Increase the separation between the equipment and receiver
- Connect the equipment into an outlet on a circuit different from that to which the receiver is connected
- Consult the dealer or an experienced radio/TV technician for help

B.1.3 Warning (Part 15.21)

Changes or modifications not expressly approved by this company could void the user's authority to operate the equipment.

B.2 Europe (ETSI)

If the device is incorporated into a product, the manufacturer must ensure compliance of the final product to the European harmonized EMC and low-voltage/safety standards. A Declaration of Conformity must be issued for each of these standards and kept on file as described in Annex II of the R&TTE Directive.

The manufacturer must maintain a copy of the device documentation and ensure the final product does not exceed the specified power ratings, and/or installation requirements as specified in the user manual. If any of

these specifications are exceeded in the final product, a submission must be made to a notified body for compliance testing to all required standards. The “CE” marking must be affixed to a visible location on the OEM product. The CE mark shall consist of the initials “CE” taking the following form:

- If the CE marking is reduced or enlarged, the proportions given in the above graduated drawing must be respected
- The CE marking must have a height of at least 5mm except where this is not possible on account of the nature of the apparatus
- The CE marking must be affixed visibly, legibly, and indelibly

More detailed information about CE marking requirements you can find at "DIRECTIVE 1999/5/EC OF THE EUROPEAN PARLIAMENT AND OF THE COUNCIL" on 9 March 1999 at section 12.

Appendix C Revision History

Doc Rev.	Date	Comments
42097B	06/2014	"The ATREB212BSMA-EK is certified as Limited modular transmitter with FCC ID VW4A091619" is added in B.1.1. New template.
42097A	04/2013	Initial document release.

Atmel®, Atmel logo and combinations thereof, AVR®, Enabling Unlimited Possibilities®, STK®, and others are registered trademarks or trademarks of Atmel Corporation in U.S. and other countries. Other terms and product names may be trademarks of others.

DISCLAIMER: The information in this document is provided in connection with Atmel products. No license, express or implied, by estoppel or otherwise, to any intellectual property right is granted by this document or in connection with the sale of Atmel products. EXCEPT AS SET FORTH IN THE ATMEL TERMS AND CONDITIONS OF SALES LOCATED ON THE ATMEL WEBSITE, ATMEL ASSUMES NO LIABILITY WHATSOEVER AND DISCLAIMS ANY EXPRESS, IMPLIED OR STATUTORY WARRANTY RELATING TO ITS PRODUCTS INCLUDING, BUT NOT LIMITED TO, THE IMPLIED WARRANTY OF MERCHANTABILITY, FITNESS FOR A PARTICULAR PURPOSE, OR NON-INFRINGEMENT. IN NO EVENT SHALL ATMEL BE LIABLE FOR ANY DIRECT, INDIRECT, CONSEQUENTIAL, PUNITIVE, SPECIAL OR INCIDENTAL DAMAGES (INCLUDING, WITHOUT LIMITATION, DAMAGES FOR LOSS AND PROFITS, BUSINESS INTERRUPTION, OR LOSS OF INFORMATION) ARISING OUT OF THE USE OR INABILITY TO USE THIS DOCUMENT, EVEN IF ATMEL HAS BEEN ADVISED OF THE POSSIBILITY OF SUCH DAMAGES. Atmel makes no representations or warranties with respect to the accuracy or completeness of the contents of this document and reserves the right to make changes to specifications and products descriptions at any time without notice. Atmel does not make any commitment to update the information contained herein. Unless specifically provided otherwise, Atmel products are not suitable for, and shall not be used in, automotive applications. Atmel products are not intended, authorized, or warranted for use as components in applications intended to support or sustain life.

SAFETY-CRITICAL, MILITARY, AND AUTOMOTIVE APPLICATIONS DISCLAIMER: Atmel products are not designed for and will not be used in connection with any applications where the failure of such products would reasonably be expected to result in significant personal injury or death ("Safety-Critical Applications") without an Atmel officer's specific written consent. Safety-Critical Applications include, without limitation, life support devices and systems, equipment or systems for the operation of nuclear facilities and weapons systems. Atmel products are not designed nor intended for use in military or aerospace applications or environments unless specifically designated by Atmel as military-grade. Atmel products are not designed nor intended for use in automotive applications unless specifically designated by Atmel as automotive-grade.

X-ON Electronics

Largest Supplier of Electrical and Electronic Components

Click to view similar products for [Zigbee Development Tools - 802.15.4 category](#):

Click to view products by [Microchip manufacturer](#):

Other Similar products are found below :

[EVAL_PAN4555ETU](#) [4467CPCE10D868](#) [STEVAL-IFS013V2](#) [DFR0015](#) [DFR0050](#) [WRL-14549](#) [BOB-13311](#) [ATRCB256RFR2-XPRO](#)
[ATREB231ED-EK](#) [ATREB233-XPRO](#) [ATZB-A-233-XPRO](#) [ATZB-X-212B-USB](#) [ATZB-X-233-USB](#) [ATZB-X-233-XPRO](#) [76000956](#) [XK-](#)
[WDM](#) [IS.OMB-001](#) [DM182016-1](#) [MIKROE-4277](#) [MIKROE-1599](#) [MIKROE-290](#) [MIKROE-987](#) [FRDM-KW41Z](#) [113020004](#) [EM35X-](#)
[BBRD](#) [RBK-ZW500-E2](#) [RBK-ZW500-H2](#) [RBK-ZW500-U2](#) [RD-0039-0201](#) [RFX2411N-EVB](#) [WRL-11373](#) [WRL-11812](#) [WRL-12847](#)
[CC2538-CC2592EMK](#) [101-1272](#) [SKY66114-11-EK1](#) [SKY66403-11EK1](#) [SKY66112-11EK1](#) [XB24-DKS](#) [XB24-DKS-INT](#) [XB24-DKSJ](#)
[XB24-DMDK](#) [XB24-DMDK-WJ](#) [XB24-PDKJ](#) [XBEE-MP-MCRO](#) [XBEE-MP-SMT](#) [XBEE-MP-TH](#) [XBIB-CU-TH](#) [XBP09-DMDK](#) [XBP24-](#)
[DKS](#)