

ATSAMA5D27-WLSOM1

Introduction

The Microchip SAMA5D27 Wireless System-On-Module 1 (ATSAMA5D27-WLSOM1) is a small single-sided SOM based on the high-performance System-in-Package (SiP) 32-bit Arm® Cortex®-A5 processor-based MPU SAMA5D27, 2 Gb LPDDR2-SDRAM running up to 500 MHz, and Wi-Fi® plus Bluetooth® (Wi-Fi/BT) Wireless module.

The ATSAMA5D27-WLSOM1 is built on a common set of proven Microchip components to reduce time to market by simplifying hardware design and software development.

The ATSAMA5D27-WLSOM1 also limits design rules of the main application board, reducing overall PCB complexity and cost. The ATSAMA5D27-WLSOM1 is delivered with a free Linux® distribution and bare metal C examples.

Figure 1. ATSAMA5D27-WLSOM1 Overview



Features

- System-In-Package (ATSAMA5D27C-LD2G-CU) Including:
 - Arm® Cortex®-A5 processor-based SAMA5D27 MPU
 - 2 Gbit LPDDR2-SDRAM
- On-Board Power Management Unit (MCP16502AC-E/S8B)
- 64 Mb Serial Quad I/O Flash Memory (SST26VF064BEUIT-104I/MF) with Embedded EUI-48™ and EUI-64™ MAC Addresses
- IEEE® 802.11 b/g/n Wi-Fi plus Bluetooth (Wi-Fi/BT) Module (ATWILC3000-MR110UA)
- 10Base-T/100Base-TX Ethernet PHY (KSZ8081RNAIA)
- ATECC608B-TNGTLS Secure Element
- MEMS Oscillators for Clock Generation
- 40.8 x 40.8 mm Module, Pitch 0.8mm, Solderable Manually for Prototyping
- 94 I/Os
- Up to 7 Tamper Pins
- One USB Device, one USB Host and one HSIC Interface
- Shutdown and Reset Control Pins
- Independent Power Supplies Available for Camera Sensor, for SD Card and for Backup Depending on Voltage Domains
- Operational Specifications:
 - Main operating voltage: 3.0V to 5.5V ± 5%
 - Temperature range: -40°C to 85°C
 - Integrated oscillators, internal voltage regulators
 - Multiple interfaces and I/Os for easy application development

Applications

- Industrial Control and Automation
- Smart Appliances
- Human Machine Interfaces (HMI)
- IoT Gateway
- Access Control Panels
- Security and Alarm Systems

Table of Contents

Introduction.....	1
Features.....	2
Applications.....	2
1. Reference Documents.....	5
2. Block Diagram.....	6
3. Pinout	7
3.1. Pinout Overview.....	7
3.2. Pin List.....	7
4. Functional Description.....	21
4.1. MPU and Memory Subsystem.....	21
4.2. Power Management.....	25
4.3. LAN Subsystem.....	30
4.4. Voltage Threshold Detector.....	31
4.5. Radio Subsystem.....	32
4.6. External Interfaces.....	33
5. Electrical Characteristics.....	48
5.1. Absolute Maximum Ratings.....	48
5.2. Recommended Operating Conditions.....	48
5.3. DC Characteristics.....	48
5.4. Power Consumption.....	49
5.5. Radio Performance.....	51
6. Mechanical Characteristics.....	52
6.1. Module Outline Drawings.....	52
6.2. Module Land Pattern (Host Board PCB Footprint).....	54
6.3. Other Characteristics.....	55
7. Assembly and Storage Information.....	56
7.1. Storage Condition.....	56
7.2. Motherboard Solder Paste.....	56
7.3. Motherboard Stencil Design.....	56
7.4. Bake Information.....	56
7.5. Reflow Profile.....	57
8. Regulatory Approval.....	59
8.1. United States.....	59
8.2. Canada.....	60
8.3. Europe.....	61
8.4. Approved Antenna Types.....	63
9. Ordering Information.....	66

10. Revision History.....	67
10.1. Rev. D - 08/2021.....	67
10.2. Rev. C - 03/2021.....	67
10.3. Rev. B - 12/2019.....	68
10.4. Rev. A - 10/2019.....	68
The Microchip Website.....	69
Product Change Notification Service.....	69
Customer Support.....	69
Product Identification System.....	70
Microchip Devices Code Protection Feature.....	70
Legal Notice.....	70
Trademarks.....	71
Quality Management System.....	71
Worldwide Sales and Service.....	72

1. Reference Documents

The following reference data sheets are available on www.microchip.com:

Table 1-1. Reference Data Sheets

Document Title	Available
KSZ8081RNA/RND	www.microchip.com/wwwproducts/en/KSZ8081
SAMA5D2 SIP	www.microchip.com/wwwproducts/en/ATSAMA5D27C-LD2G
SST26VF064BEUI	www.microchip.com/wwwproducts/en/SST26VF064BEUI
MCP16502	https://www.microchip.com/wwwproducts/en/MCP16502
MIC841/2	https://www.microchip.com/wwwproducts/en/MIC842
DSC60XXB	www.microchip.com/wwwproducts/en/DSC6000B
DSC61XXB	www.microchip.com/wwwproducts/en/DSC6100B
ATWILC3000-MR110UA	https://www.microchip.com/wwwproducts/en/ATWILC3000
ATECC608B-TNGTLS	www.microchip.com/wwwproducts/en/ATECC608B-TNGTLS

SAMA5D27 Wireless SOM1

Block Diagram

2. Block Diagram

The following figure shows the block diagram of the ATSAMA5D27-WLSOM1 module.

Figure 2-1. ATSAMA5D27-WLSOM1 Module Block Diagram

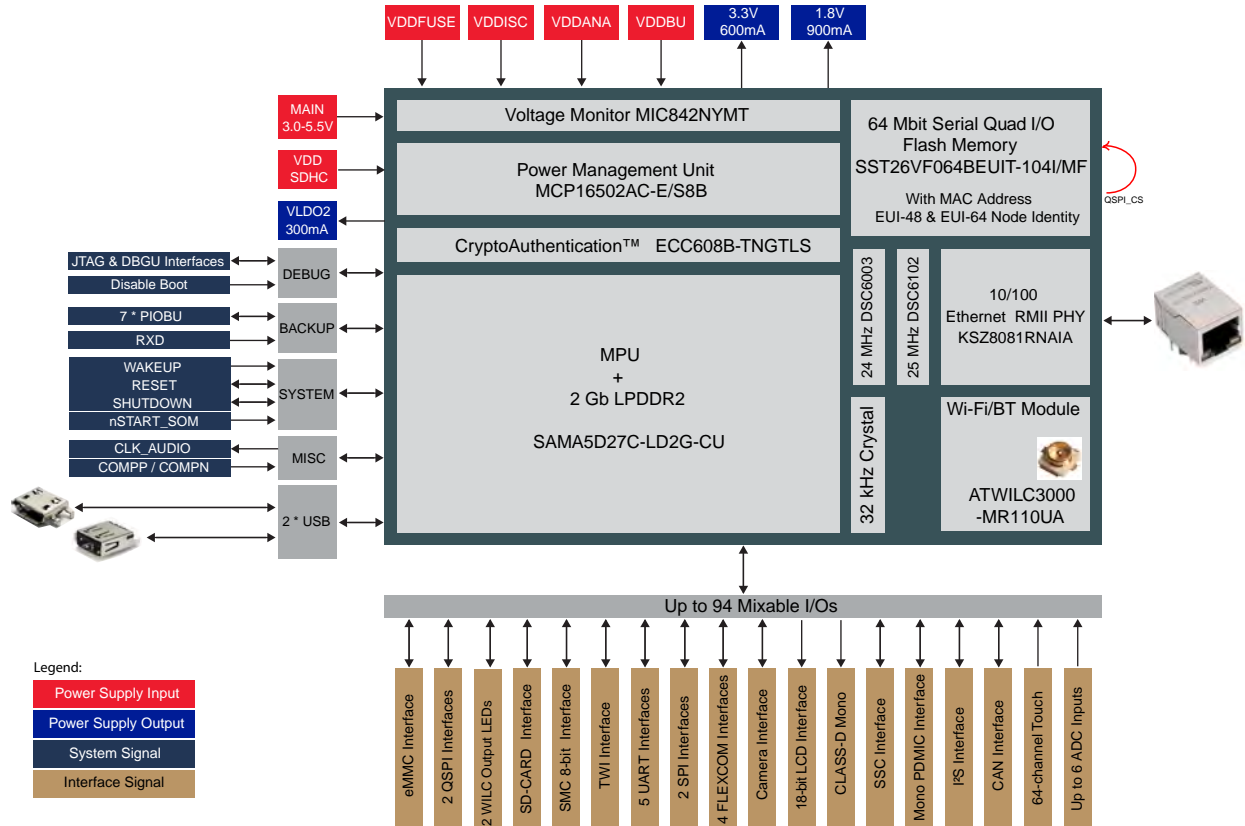

3. Pinout

3.1 Pinout Overview

Figure 3-1. ATSAM5D27-WLSOM1 Pin Assignment

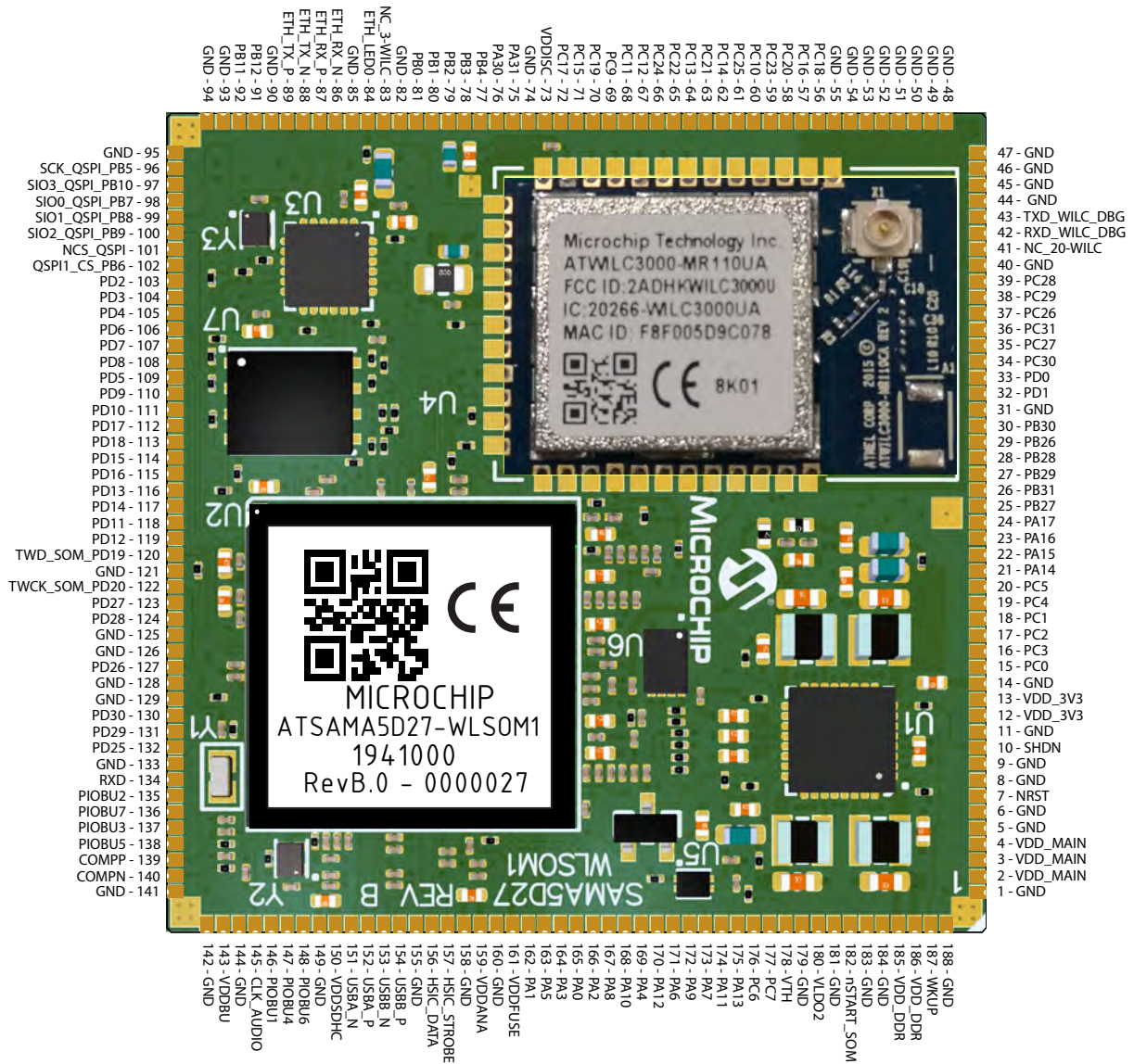

3.2 Pin List

The following tables provide the SAMA5D27-WLSOM1 module pin description.

SAMA5D27 Wireless SOM1

Pinout



Important: Compared to SAMA5D2 Series devices, some PIO features are not listed. These features are used internally on the SAMA5D27-WLSOM1 and cannot be shared with other PIOs for use with features or for signal integrity.

3.2.1 PIOA Pin Description

Table 3-1. PIOA Pin Description

Pad No.	Power Rail	I/O Type	Primary		Alternate		PIO Peripheral				Reset State (Signal, Dir, PU, PD, HiZ, ST)	Note
			Signal	Dir	Signal	Dir	Func	Signal	Dir	IO Set		
W11	VDDSDHC	GPIO_EMMC	PA0	I/O	-	-	A	SDMMC0_CK	I/O	1	PIO, I, PU, ST	
							B	QSPI0_SCK	O	1		
							F	D0	I/O	2		
R9	VDDSDHC	GPIO_EMMC	PA1	I/O	-	-	A	SDMMC0_CMD	I/O	1	PIO, I, PU, ST	
							B	QSPI0_CS	O	1		
							F	D1	I/O	2		
W12	VDDSDHC	GPIO_EMMC	PA2	I/O	-	-	A	SDMMC0_DAT0	I/O	1	PIO, I, PU, ST	
							B	QSPI0_IO0	I/O	1		
							F	D2	I/O	2		
V11	VDDSDHC	GPIO_EMMC	PA3	I/O	-	-	A	SDMMC0_DAT1	I/O	1	PIO, I, PU, ST	
							B	QSPI0_IO1	I/O	1		
							F	D3	I/O	2		
W14	VDDSDHC	GPIO_EMMC	PA4	I/O	-	-	A	SDMMC0_DAT2	I/O	1	PIO, I, PU, ST	
							B	QSPI0_IO2	I/O	1		
							F	D4	I/O	2		
V10	VDDSDHC	GPIO_EMMC	PA5	I/O	-	-	A	SDMMC0_DAT3	I/O	1	PIO, I, PU, ST	
							B	QSPI0_IO3	I/O	1		
							F	D5	I/O	2		
W15	VDDSDHC	GPIO_EMMC	PA6	I/O	-	-	A	SDMMC0_DAT4	I/O	1	PIO, I, PU, ST	Note (2)
							B	QSPI1_SCK	O	1		
							D	TIOA5	I/O	1		
							E	FLEXCOM2_IO0	I/O	1		
							F	D6	I/O	2		
W16	VDDSDHC	GPIO_EMMC	PA7	I/O	-	-	A	SDMMC0_DAT5	I/O	1	PIO, I, PU, ST	Note (2)
							B	QSPI1_IO0	I/O	1		
							D	TIOB5	I/O	1		
							E	FLEXCOM2_IO1	I/O	1		
							F	D7	I/O	2		

SAMA5D27 Wireless SOM1

Pinout

.....continued

Pad No.	Power Rail	I/O Type	Primary		Alternate		PIO Peripheral				Reset State (Signal, Dir, PU, PD, HiZ, ST)	Note
			Signal	Dir	Signal	Dir	Func	Signal	Dir	IO Set		
V12	VDDSDHC	GPIO_EMMC	PA8	I/O	-	-	A	SDMMC0_DAT6	I/O	1	PIO, I, PU, ST	Note (2)
							B	QSPI1_IO1	I/O	1		
							D	TCLK5	I	1		
							E	FLEXCOM2_IO2	I/O	1		
							F	NWE/NANDWE	O	2		
V16	VDDSDHC	GPIO_EMMC	PA9	I/O	-	-	A	SDMMC0_DAT7	I/O	1	PIO, I, PU, ST	Note (2)
							B	QSPI1_IO2	I/O	1		
							D	TIOA4	I/O	1		
							E	FLEXCOM2_IO3	O	1		
							F	NCS3	O	2		
V14	VDDSDHC	GPIO_EMMC	PA10	I/O	-	-	A	SDMMC0_RSTN	O	1	PIO, I, PU, ST	Note (2)
							B	QSPI1_IO3	I/O	1		
							D	TIOB4	I/O	1		
							E	FLEXCOM2_IO4	O	1		
							F	A21/NANDALE	O	2		
L18	VDD_3V3	GPIO	PA11	I/O	-	-	A	SDMMC0_VDDSEL	O	1	PIO, I, PU, ST	
							B	QSPI1_CS	O	1		
							D	TCLK4	I	1		
							F	A22/NANDCLE	O	2		
T16	VDD_3V3	GPIO	PA12	I/O	-	-	A	SDMMC0_WP	I	1	PIO, I, PU, ST	
							B	IRQ	I	1		
							F	NRD/NANDOE	O	2		
K18	VDD_3V3	GPIO	PA13	I/O	-	-	A	SDMMC0_CD	I	1	PIO, I, PU, ST	Note (3)
							E	FLEXCOM3_IO1	I/O	1		
R19	VDD_3V3	GPIO_QSPI	PA14	I/O	-	-	A	SPI0_SPCK	I/O	1	PIO, I, PU, ST	Note (3)
							B	TK1	I/O	1		
							D	I2SMCK1	O	2		
							E	FLEXCOM3_IO2	I/O	1		
L17	VDD_3V3	GPIO	PA15	I/O	-	-	A	SPI0_MOSI	I/O	1	PIO, I, PU, ST	Note (3)
							B	TF1	I/O	1		
							D	I2SCK1	I/O	2		
							E	FLEXCOM3_IO0	I/O	1		

SAMA5D27 Wireless SOM1

Pinout

.....continued

Pad No.	Power Rail	I/O Type	Primary		Alternate		PIO Peripheral				Reset State (Signal, Dir, PU, PD, HiZ, ST)	Note
			Signal	Dir	Signal	Dir	Func	Signal	Dir	IO Set		
N19	VDD_3V3	GPIO_IO	PA16	I/O	-	-	A	SPI0_MISO	I/O	1	PIO, I, PU, ST	Note (3)
							B	TD1	O	1		
							D	I2SWS1	I/O	2		
							E	FLEXCOM3_IO3	O	1		
M16	VDD_3V3	GPIO_IO	PA17	I/O	-	-	A	SPI0_NPCS0	I/O	1	PIO, I, PU, ST	Note (3)
							D	I2SDI1	I	2		
							E	FLEXCOM3_IO4	O	1		
U12	VDD_3V3	GPIO	PA30	I/O	-	-	C	SPI0_NPCS0	I/O	2	PIO, I, PU, ST	Note (3)
							D	PWMH0	O	1		
U17	VDD_3V3	GPIO	PA31	I/O	-	-	C	SPI0_MISO	I/O	2	PIO, I, PU, ST	Note (3)
							D	PWML0	O	1		

Notes:

1. Fixed feature due to the WLSOM1 internal connection.
2. Limited feature compared to SAMA5D2 due to the WLSOM1 internal use of specific functionality, for example, QSPI, GMAC.
3. Limited feature compared to SAMA5D2 due to the use of a part of the functionality for other features in the WLSOM1, for example, GMAC, ISC, FLEXCOM, etc.

3.2.2 PIOB Pin Description

Table 3-2. PIOB Pin Description

Pad No.	Power Rail	I/O Type	Primary		Alternate		PIO Peripheral				Reset State (Signal, Dir, PU, PD, HiZ, ST)	Note
			Signal	Dir	Signal	Dir	Func	Signal	Dir	IO Set		
C7	VDD_3V3	GPIO	PB0	I/O	-	-	C	SPI0_MOSI	I/O	2	PIO, I, PU, ST	Note (3)
							D	PWMH1	O	1		
A9	VDD_3V3	GPIO	PB1	I/O	-	-	C	SPI0_SPCK	I/O	2	PIO, I, PU, ST	Note (3)
							D	PWML1	O	1		
							F	CLASSD_R0	O	1		
A10	VDD_3V3	GPIO	PB2	I/O	-	-	D	PWMF10	I	1	PIO, I, PU, ST	Note (3)
							F	CLASSD_R1	O	1		
A11	VDD_3V3	GPIO	PB3	I/O	-	-	A	URXD4	I	1	PIO, I, PU, ST	Note (3)
							C	IRQ	I	3		
							D	PWMEXTRG0	I	1		
							F	CLASSD_R2	O	1		
A12	VDD_3V3	GPIO	PB4	I/O	-	-	A	UTXD4	O	1	PIO, I, PU, ST	Note (3)
							C	FIQ	I	4		
							F	CLASSD_R3	O	1		

SAMA5D27 Wireless SOM1

Pinout

.....continued

Pad No.	Power Rail	I/O Type	Primary		Alternate		PIO Peripheral				Reset State (Signal, Dir, PU, PD, HiZ, ST)	Note
			Signal	Dir	Signal	Dir	Func	Signal	Dir	IO Set		
A7	VDD_3V3	GPIO_QSPI	PB5	I/O	-	-	A	TCLK2	I	1	PIO, I, PU, ST	Note (2) Note (3)
							C	PWMH2	O	1		
							D	QSPI1_SCK	O	2		
B7	VDD_3V3	GPIO	PB6	I/O	-	-	A	TIOA2	I/O	1	PIO, I, PU, ST	Note (2) Note (3)
							C	PWML2	O	1		
							D	QSPI1_CS	O	2		
C5	VDD_3V3	GPIO_IO	PB7	I/O	-	-	A	TIOB2	I/O	1	PIO, I, PU, ST	Note (2) Note (3)
							C	PWMH3	O	1		
							D	QSPI1_IO0	I/O	2		
B8	VDD_3V3	GPIO_IO	PB8	I/O	-	-	A	TCLK3	I	1	PIO, I, PU, ST	Note (2) Note (3)
							C	PWML3	O	1		
							D	QSPI1_IO1	I/O	2		
B6	VDD_3V3	GPIO_IO	PB9	I/O	-	-	A	TIOA3	I/O	1	PIO, I, PU, ST	Note (2) Note (3)
							C	PWMF1	I	1		
							D	QSPI1_IO2	I/O	2		
G6	VDD_3V3	GPIO_IO	PB10	I/O	-	-	A	TIOB3	I/O	1	PIO, I, PU, ST	Note (2) Note (3)
							C	PWMEXTRG1	I	1		
							D	QSPI1_IO3	I/O	2		
B5	VDD_3V3	GPIO	PB11	I/O	-	-	C	URXD3	I	3	PIO, I, PU, ST	Note (3)
							D	PDMIC_DAT0	I/O	2		
A6	VDD_3V3	GPIO	PB12	I/O	-	-	C	UTXD3	O	3	PIO, I, PU, ST	Note (3)
							D	PDMIC_CLK0	O	2		
G2	VDD_3V3	GPIO	PB26	I/O	-	-	C	URXD0	I	1	PIO, I, PU, ST	Note (3)
							D	PDMIC_DAT0	I/O	1		
							F	ISL_D0	I	3		
H5	VDD_3V3	GPIO	PB27	I/O	-	-	C	UTXD0	O	1	PIO, I, PU, ST	Note (3)
							D	PDMIC_CLK0	O	1		
							F	ISL_D1	I	3		
J2	VDD_3V3	GPIO	PB28	I/O	-	-	C	FLEXCOM0_IO0	I/O	1	PIO, I, PU, ST	Note (3)
							D	TIOA5	I/O	2		
							F	ISL_D2	I	3		
J3	VDD_3V3	GPIO	PB29	I/O	-	-	C	FLEXCOM0_IO1	I/O	1	PIO, I, PU, ST	Note (3)
							D	TIOB5	I/O	2		
							F	ISL_D3	I	3		

SAMA5D27 Wireless SOM1

Pinout

.....continued

Pad No.	Power Rail	I/O Type	Primary		Alternate		PIO Peripheral				Reset State (Signal, Dir, PU, PD, HiZ, ST)	Note
			Signal	Dir	Signal	Dir	Func	Signal	Dir	IO Set		
A2	VDD_3V3	GPIO	PB30	I/O	-	-	C	FLEXCOM0_IO2	I/O	1	PIO, I, PU, ST	Note (3)
							D	TCLK5	I	2		
							F	ISI_D4	I	3		
J4	VDD_3V3	GPIO	PB31	I/O	-	-	C	FLEXCOM0_IO3	O	1	PIO, I, PU, ST	Note (3)
							F	ISI_D5	I	3		

Notes:

1. Fixed feature due to the WLSOM1 internal connection.
2. Limited feature compared to SAMA5D2 due to the WLSOM1 internal use of specific functionality, for example, QSPI, GMAC.
3. Limited feature compared to SAMA5D2 due to the use of a part of the functionality for other features in the WLSOM1, for example, GMAC, ISC, FLEXCOM, etc.

3.2.3 PIOC Pin Description

Table 3-3. PIOC Pin Description

Pad No.	Power Rail	I/O Type	Primary		Alternate		PIO Peripheral				Reset State (Signal, Dir, PU, PD, HiZ, ST)	Note
			Signal	Dir	Signal	Dir	Func	Signal	Dir	IO Set		
T14	VDD_3V3	GPIO	PC0	I/O	-	-	C	FLEXCOM0_IO4	O	1	PIO, I, PU, ST	Note (3)
							F	ISI_D6	I	3		
R16	VDD_3V3	GPIO	PC1	I/O	-	-	C	CANTX0	O	1	PIO, I, PU, ST	Note (3)
							D	SPI1_SPCK	I/O	1		
							E	I2SCK0	I/O	1		
							F	ISI_D7	I	3		
T15	VDD_3V3	GPIO	PC2	I/O	-	-	C	CANRX0	I/O	1	PIO, I, PU, ST	Note (3)
							D	SPI1_MOSI	I/O	1		
							E	I2SMCK0	O	1		
							F	ISI_D8	I	3		
T13	VDD_3V3	GPIO	PC3	I/O	-	-	C	TIOA1	I/O	1	PIO, I, PU, ST	Note (3)
							D	SPI1_MISO	I/O	1		
							E	I2SWS0	I/O	1		
							F	ISI_D9	I	3		
P16	VDD_3V3	GPIO	PC4	I/O	-	-	C	TIOB1	I/O	1	PIO, I, PU, ST	Note (3)
							D	SPI1_NPCS0	I/O	1		
							E	I2SDI0	I	1		
							F	ISI_PCK	I	3		

SAMA5D27 Wireless SOM1

Pinout

.....continued

Pad No.	Power Rail	I/O Type	Primary		Alternate		PIO Peripheral				Reset State (Signal, Dir, PU, PD, HiZ, ST)	Note
			Signal	Dir	Signal	Dir	Func	Signal	Dir	IO Set		
L19	VDD_3V3	GPIO	PC5	I/O	-	-	C	TCLK1	I	1	PIO, I, PU, ST	Note (3)
							D	SPI1_NPCS1	O	1		
							E	I2SD00	O	1		
							F	ISI_VSYNC	I	3		
R15	VDD_3V3	GPIO	PC6	I/O	-	-	D	SPI1_NPCS2	O	1	PIO, I, PU, ST	Note (3)
							F	ISI_HSYNC	I	3		
N15	VDD_3V3	GPIO_CLK	PC7	I/O	-	-	D	SPI1_NPCS3	O	1	PIO, I, PU, ST	Note (3)
							F	ISI_MCK	O	3		
B2	VDDISC	GPIO	PC9	I/O	-	-	A	FIQ	I	3	PIO, I, PU, ST	Note (2)
							C	ISI_D0	I	1		
							D	TIOA4	I/O	2		
K5	VDDISC	GPIO	PC10	I/O	-	-	A	LCDDAT2	O	2	PIO, I, PU, ST	Note (2)
							C	ISI_D1	I	1		
							D	TIOB4	I/O	2		
							E	CANTX0	O	2		
C2	VDDISC	GPIO	PC11	I/O	-	-	A	LCDDAT3	O	2	PIO, I, PU, ST	Note (2)
							C	ISI_D2	I	1		
							D	TCLK4	I	2		
							E	CANRX0	I	2		
							F	A0/NBS0	O	2		
D2	VDDISC	GPIO	PC12	I/O	-	-	A	LCDDAT4	O	2	PIO, I, PU, ST	Note (2)
							C	ISI_D3	I	1		
							D	URXD3	I	1		
							E	TK0	I/O	2		
							F	A1	O	2		
K2	VDDISC	GPIO	PC13	I/O	-	-	A	LCDDAT5	O	2	PIO, I, PU, ST	Note (2)
							C	ISI_D4	I	1		
							D	UTXD3	O	1		
							E	TF0	I/O	2		
							F	A2	O	2		
K6	VDDISC	GPIO	PC14	I/O	-	-	A	LCDDAT6	O	2	PIO, I, PU, ST	Note (2)
							C	ISI_D5	I	1		
							E	TD0	O	2		
							F	A3	O	2		

SAMA5D27 Wireless SOM1

Pinout

.....continued

Pad No.	Power Rail	I/O Type	Primary		Alternate		PIO Peripheral				Reset State (Signal, Dir, PU, PD, HiZ, ST)	Note
			Signal	Dir	Signal	Dir	Func	Signal	Dir	IO Set		
B1	VDDISC	GPIO	PC15	I/O	-	-	A	LCDDAT7	O	2	PIO, I, PU, ST	Note (2)
							C	ISI_D6	I	1		
							E	RD0	I	2		
							F	A4	O	2		
K9	VDDISC	GPIO	PC16	I/O	-	-	A	LCDDAT10	O	2	PIO, I, PU, ST	Note (2)
							C	ISI_D7	I	1		
							E	RK0	I/O	2		
							F	A5	O	2		
C1	VDDISC	GPIO	PC17	I/O	-	-	A	LCDDAT11	O	2	PIO, I, PU, ST	Note (2)
							C	ISI_D8	I	1		
							E	RF0	I/O	2		
							F	A6	O	2		
L9	VDDISC	GPIO	PC18	I/O	-	-	A	LCDDAT12	O	2	PIO, I, PU, ST	Note (2)
							C	ISI_D9	I	1		
							E	FLEXCOM3_IO2	I/O	2		
							F	A7	O	2		
D1	VDDISC	GPIO	PC19	I/O	-	-	A	LCDDAT13	O	2	PIO, I, PU, ST	Note (2)
							C	ISI_D10	I	1		
							E	FLEXCOM3_IO1	I/O	2		
							F	A8	O	2		
L8	VDDISC	GPIO	PC20	I/O	-	-	A	LCDDAT14	O	2	PIO, I, PU, ST	Note (2)
							C	ISI_D11	I	1		
							E	FLEXCOM3_IO0	I/O	2		
							F	A9	O	2		
E3	VDDISC	GPIO	PC21	I/O	-	-	A	LCDDAT15	O	2	PIO, I, PU, ST	Note (2)
							C	ISI_PCK	I	1		
							E	FLEXCOM3_IO3	O	2		
							F	A10	O	2		
E2	VDDISC	GPIO	PC22	I/O	-	-	A	LCDDAT18	O	2	PIO, I, PU, ST	Note (2)
							C	ISI_VSYNC	I	1		
							E	FLEXCOM3_IO4	O	2		
							F	A11	O	2		
L7	VDDISC	GPIO	PC23	I/O	-	-	A	LCDDAT19	O	2	PIO, I, PU, ST	Note (2)
							C	ISI_HSYNC	I	1		
							F	A12	O	2		

SAMA5D27 Wireless SOM1

Pinout

.....continued

Pad No.	Power Rail	I/O Type	Primary		Alternate		PIO Peripheral				Reset State (Signal, Dir, PU, PD, HiZ, ST)	Note
			Signal	Dir	Signal	Dir	Func	Signal	Dir	IO Set		
E1	VDDISC	GPIO_CLK	PC24	I/O	-	-	A	LCDDAT20	O	2	PIO, I, PU, ST	Note (2)
							C	ISL_MCK	O	1		
							F	A13	O	2		
L4	VDDISC	GPIO	PC25	I/O	-	-	A	LCDDAT21	O	2	PIO, I, PU, ST	Note (2)
							C	ISI_FIELD	I	1		
							F	A14	O	2		
D6	VDD_3V3	GPIO	PC26	I/O	-	-	A	LCDDAT22	O	2	PIO, I, PU, ST	Note (2)
							D	CANTX1	O	1		
							F	A15	O	2		
E7	VDD_3V3	GPIO	PC27	I/O	-	-	A	LCDDAT23	O	2	PIO, I, PU, ST	Note (2)
							C	PCK1	O	2		
							D	CANRX1	I/O	1		
							F	A16	O	2		
J5	VDD_3V3	GPIO	PC28	I/O	-	-	A	LCDPWM	O	2	PIO, I, PU, ST	Note (2)
							B	FLEXCOM4_IO0	I/O	1		
							C	PCK2	O	1		
							F	A17	O	2		
C6	VDD_3V3	GPIO	PC29	I/O	-	-	A	LCDDISP	O	2	PIO, I, PU, ST	
							B	FLEXCOM4_IO1	I/O	1		
							F	A18	O	2		
D7	VDD_3V3	GPIO	PC30	I/O	-	-	A	LCDVSYNC	O	2	PIO, I, PU, ST	
							B	FLEXCOM4_IO2	I/O	1		
							F	A19	O	2		
C8	VDD_3V3	GPIO	PC31	I/O	-	-	A	LCDHSYNC	O	2	PIO, I, PU, ST	
							B	FLEXCOM4_IO3	O	1		
							C	URXD3	I	2		
							F	A20	O	2		

Notes:

1. Fixed feature due to the WLSOM1 internal connection.
2. Limited feature compared to SAMA5D2 due to the WLSOM1 internal use of specific functionality, for example, QSPI, GMAC.
3. Limited feature compared to SAMA5D2 due to the use of a part of the functionality for other features in the WLSOM1, for example, GMAC, ISC, FLEXCOM, etc.

SAMA5D27 Wireless SOM1

Pinout

3.2.4 PIOD Pin Description

Pad No.	Power Rail	I/O Type	Primary		Alternate		PIO Peripheral				Reset State (Signal, Dir, PU, PD, HiZ, ST)	Note
			Signal	Dir	Signal	Dir	Func	Signal	Dir	IO Set		
J7	VDD_3V3	GPIO_CLK	PD0	I/O	-	-	A	LCDPCK	O	2	PIO, I, PU, ST	
							B	FLEXCOM4_IO4	O	1		
							C	UTXD3	O	2		
							D	GTSUCOMP	O	2		
							F	A23	O	2		
D8	VDD_3V3	GPIO	PD1	I/O	-	-	A	LCDDEN	O	2	PIO, I, PU, ST	
							D	GRXCK	I	2		
							F	A24	O	2		
J6	VDD_3V3	GPIO_CLK	PD2	I/O	-	-	A	URXD1	I	1	PIO, I, PU, ST	
							D	GTXER	O	2		
							E	ISI_MCK	O	2		
							F	A25	O	2		
M3	VDDANA	GPIO_AD	PD3	I/O	PTC_ROW0	-	A	UTXD1	O	1	PIO, I, PU, ST	
							B	FIQ	I	2		
							D	GCRS	I	2		
							E	ISI_D11	I	2		
							F	NWAIT	I	2		
L6	VDDANA	GPIO_AD	PD4	I/O	PTC_ROW1	-	B	URXD2	I	1	PIO, I, PU, ST	Note (2)
							D	GCOL	I	2		
							E	ISI_D10	I	2		
							F	NCS0	O	2		
L2	VDDANA	GPIO_AD	PD5	I/O	PTC_ROW2	-	B	UTXD2	O	1	PIO, I, PU, ST	Note (2)
							D	GRX2	I	2		
							E	ISI_D9	I	2		
							F	NCS1	O	2		
J1	VDDANA	GPIO_AD	PD6	I/O	PTC_ROW3	-	A	TCK	I	2	PIO, I, PU, ST	Note (2)
							D	GRX3	I	2		
							E	ISI_D8	I	2		
							F	NCS2	O	2		
L5	VDDANA	GPIO_AD	PD7	I/O	PTC_ROW4	-	A	TDI	I	2	PIO, I, PU, ST	Note (3)
							D	GTX2	O	2		
							E	ISI_D0	I	2		
							F	NWR1/NBS1	O	2		

SAMA5D27 Wireless SOM1

Pinout

.....continued

Pad No.	Power Rail	I/O Type	Primary		Alternate		PIO Peripheral				Reset State (Signal, Dir, PU, PD, HiZ, ST)	Note
			Signal	Dir	Signal	Dir	Func	Signal	Dir	IO Set		
K1	VDDANA	GPIO_AD	PD8	I/O	PTC_ROW5	-	A	TDO	O	2	PIO, I, PU, ST	Note (3)
							D	GTX3	O	2		
							E	ISI_D1	I	2		
							F	NANDRDY	I	2		
L3	VDDANA	GPIO_AD	PD9	I/O	PTC_ROW6	-	A	TMS	I	2	PIO, I, PU, ST	Note (3)
							D	GTXCK	O	2		
							E	ISI_D2	I	2		
L1	VDDANA	GPIO_AD	PD10	I/O	PTC_ROW7	-	A	NTRST	I	2	PIO, I, PU, ST	Note (3)
							D	GTXEN	O	2		
							E	ISI_D3	I	2		
N3	VDDANA	GPIO_AD	PD11	I/O	PTC_COL0	-	A	TIOA1	I/O	3	PIO, I, PU, ST	Note (3)
							B	PCK2	O	2		
							D	GRXDV	I	2		
							E	ISI_D4	I	2		
M7	VDDANA	GPIO_AD	PD12	I/O	PTC_COL1	-	A	TIOB1	I/O	3	PIO, I, PU, ST	Note (3)
							B	FLEXCOM4_IO0	I/O	2		
							D	GRXER	I	2		
							E	ISI_D5	I	2		
N2	VDDANA	GPIO_AD	PD13	I/O	PTC_COL2	-	A	TCLK1	I	3	PIO, I, PU, ST	Note (3)
							B	FLEXCOM4_IO1	I/O	2		
							D	GRX0	I	2		
							E	ISI_D6	I	2		
M6	VDDANA	GPIO_AD	PD14	I/O	PTC_COL3	-	A	TCK	I	1	PIO, I, PU, ST	Note (3)
							B	FLEXCOM4_IO2	I/O	2		
							D	GRX1	I	2		
							E	ISI_D7	I	2		
M5	VDDANA	GPIO_AD	PD15	I/O	PTC_COL4	-	A	TDI	I	1	PIO, I, PU, ST	Note (3)
							B	FLEXCOM4_IO3	O	2		
							D	GTX0	O	2		
							E	ISI_PCK	I	2		
M1	VDDANA	GPIO_AD	PD16	I/O	PTC_COL5	-	A	TDO	O	1	PIO, I, PU, ST	Note (3)
							B	FLEXCOM4_IO4	O	2		
							D	GTX1	O	2		
							E	ISI_VSYNC	I	2		

SAMA5D27 Wireless SOM1

Pinout

.....continued

Pad No.	Power Rail	I/O Type	Primary		Alternate		PIO Peripheral				Reset State (Signal, Dir, PU, PD, HiZ, ST)	Note
			Signal	Dir	Signal	Dir	Func	Signal	Dir	IO Set		
M2	VDDANA	GPIO_AD	PD17	I/O	PTC_COL6	-	A	TMS	I	1	PIO, I, PU, ST	Note (3)
							D	GMDC	O	2		
							E	ISI_HSYNC	I	2		
M4	VDDANA	GPIO_AD	PD18	I/O	PTC_COL7	-	A	NTRST	I	1	PIO, I, PU, ST	Note (3)
							D	GMDIO	I/O	2		
							E	ISI_FIELD	I	2		
M8	VDDANA	GPIO_AD	PD19	I/O	-	-	B	TWD1	I/O	3	PIO, I, PU, ST	Note (1)
N1	VDDANA	GPIO_AD	PD20	I/O	-	-	B	TWCK1	I/O	3	PIO, I, PU, ST	Note (1)
P8	VDDANA	GPIO_AD	PD25	I/O	AD6	-	A	SPI1_SPCK	O	3	PIO, I, PU, ST	
P2	VDDANA	GPIO_AD	PD26	I/O	AD7	-	A	SPI1_MOSI	I/O	3	PIO, I, PU, ST	
							C	FLEXCOM2_IO0	I/O	2		
N5	VDDANA	GPIO_AD	PD27	I/O	AD8	-	A	SPI1_MISO	I/O	3	PIO, I, PU, ST	
							B	TCK	I	3		
							C	FLEXCOM2_IO1	I/O	2		
N4	VDDANA	GPIO_AD	PD28	I/O	AD9	-	A	SPI1_NPCS0	I/O	3	PIO, I, PU, ST	
							B	TDI	I	3		
							C	FLEXCOM2_IO2	I/O	2		
R2	VDDANA	GPIO_AD	PD29	I/O	AD10	-	A	SPI1_NPCS1	O	3	PIO, I, PU, ST	Note (2)
							B	TDO	O	3		
							C	FLEXCOM2_IO3	O	2		
							D	TIOA3	I/O	3		
N10	VDDANA	GPIO_AD	PD30	I/O	AD11	-	A	SPI1_NPCS2	O	3	PIO, I, PU, ST	Note (2)
							B	TMS	I	3		
							C	FLEXCOM2_IO4	O	2		
							D	TIOB3	I/O	3		

Notes:

1. Fixed feature due to the WLSOM1 internal connection.
2. Limited feature compared to SAMA5D2 due to the WLSOM1 internal use of specific functionality, for example, QSPI, GMAC.
3. Limited feature compared to SAMA5D2 due to the use of a part of the functionality for other features in the WLSOM1, for example, GMAC, ISC, FLEXCOM, etc.

3.2.5 System Pins Description

Table 3-4. System Pins Description

Pin No.	Pin Name	Power Rail	Description
145	CLK_AUDIO	VDD_3V3	Audio Main System Bus Clock Frequency Output
151	USBA_N	VDD_3V3	USB Device High-Speed Data -

SAMA5D27 Wireless SOM1

Pinout

.....continued

Pin No.	Pin Name	Power Rail	Description
152	USBA_P	VDD_3V3	USB Device High-Speed Data +
157	HSIC_STROBE	VDDHSIC (1.2V)	USB High-Speed Inter-Chip Strobe
156	HSIC_DATA	VDDHSIC (1.2V)	USB High-Speed Inter-Chip Data
153	USBB_N	VDD_3V3	USB Host Port B High-Speed Data -
154	USBB_P	VDD_3V3	USB Host Port B High-Speed Data +
7	NRST	VDDDBU	Module Reset
140	COMP_N	VDDDBU	External Analog Data Input
139	COMP_P	VDDDBU	External Analog Data Input
146	PIOBU1	VDDDBU	Tamper I/O #1
135	PIOBU2	VDDDBU	Tamper I/O #2
137	PIOBU3	VDDDBU	Tamper I/O #3
147	PIOBU4	VDDDBU	Tamper I/O #4
138	PIOBU5	VDDDBU	Tamper I/O #5
148	PIOBU6	VDDDBU	Tamper I/O #6
136	PIOBU7	VDDDBU	Tamper I/O #7
134	RXD	VDDDBU	RXLP Receive Data Input
10	SHDN	VDDDBU	Shutdown Control
187	WKUP	VDDDBU	Module Wake-Up
178	VTH	VDD_MAIN	Low Voltage Threshold Detection Input
101	NCS_QSPI	VDD_3V3	Embedded QSPI Chip Select Input
83	NC	-	Not connected
41	NC	-	Not connected
89	ETH_TX_P	-	Physical Transmit Signal (+ differential)
88	ETH_TX_N	-	Physical Transmit Signal (- differential)
87	ETH_RX_P	-	Physical Receive Signal (+ differential)
86	ETH_RX_N	-	Physical Receive Signal (- differential)
84	ETH_LED0	VDD_3V3	Programmable LED0 Output
182	nSTART_SOM	VDD_MAIN	Module Start-Up Control Input
42	RXD_WILC_DBG	VDD_3V3	Used for Radio Debug. UART RXD
43	TXD_WILC_DBG	VDD_3V3	Used for Radio Debug. UART TXD

3.2.6 Power Pins Description

Table 3-5. Power Pins Description

Pin No.	Pin Name	Power Rail	Type	Description
1, 5, 6, 8, 9, 11, 14, 31, 40, 44, 45, 46, 47, 48, 49, 50, 51, 52, 53, 54, 55, 74, 82, 85, 90, 93, 94, 95, 121, 125, 126, 129, 133, 141, 142, 144, 128, 149, 155, 158, 160, 179, 181, 183, 184, 188	GND	GND	GND	Ground
159	VDDANA	VDDANA	I	Analog Voltage Input

SAMA5D27 Wireless SOM1

Pinout

.....continued

Pin No.	Pin Name	Power Rail	Type	Description
143	VDDBU	VDDBU	I	Backup Voltage Input
161	VDDFUSE	VDDFUSE	I	VDDFUSE Voltage Input
73	VDDISC	VDDISC	I	VDDISC Voltage Input
2, 3, 4	VDD_MAIN	VDD_MAIN	I	Main Input Voltage
12, 13	VDD_3V3	VDD_3V3	O	3.3V Voltage Output
180	VLDO2	VLDO2	O	VLDO2 Output Voltage
150	VDDSDHC	VDDSDHC	I	VDDSDHC Input Voltage
185, 186	VDD_DDR	VDD_DDR	O	1.8V Output Voltage

4. Functional Description

4.1 MPU and Memory Subsystem

4.1.1 SAMA5D27 System-In-Package

The SAMA5D27 System-In-Package (SiP) (ATSAMA5D27C-LD2G-CU) integrates the ARM Cortex-A5 processor-based SAMA5D2 MPU with 2 Gbit LPDDR2-SDRAM in a single package.

By combining the high-performance, ultra-low power SAMA5D2 with LPDDR2-SDRAM in a single package, PCB routing complexity, area and number of layers is reduced. This makes board design easier and lowers the overall cost of the bill of materials. Board design is more robust by facilitating design for EMI, ESD and signal integrity.

For more information about the SiP, see [Reference Documents](#). The sole reference documents for product information on the SAMA5D2 and the LPDDR2-SDRAM memory are provided in this section.

The ATSAMA5D27C-LD2G-CU is available in a 361-ball TFBGA package.

Connections of the supplies and the system pins of the ATSAMA5D27C-LD2G-CU are described in the following schematics.

Figure 4-1. SAMA5D27 SiP Schematic

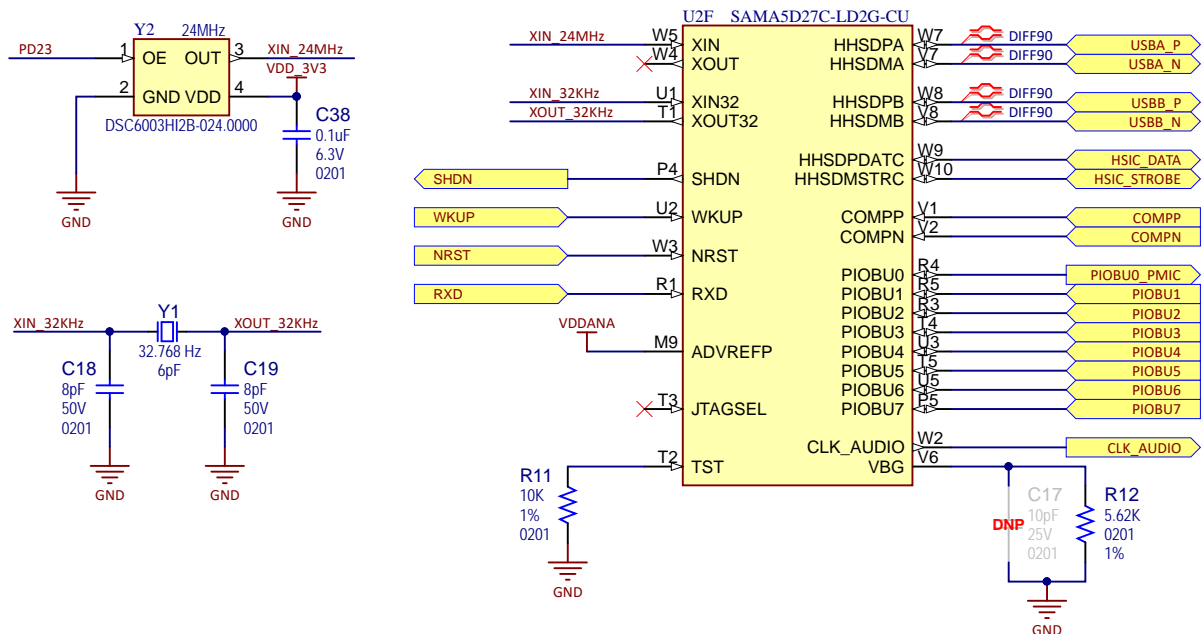

SAMA5D27 Wireless SOM1

Functional Description

Figure 4-2. SAMA5D27 SiP Decoupling Schematic

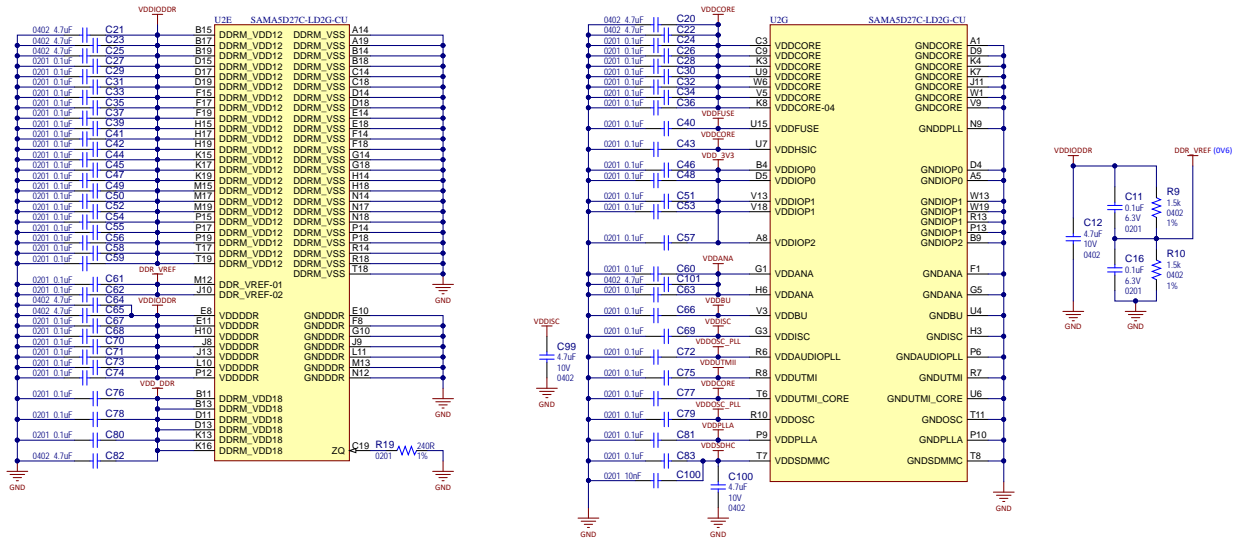

4.1.2 Power Management Unit

The MCP16502 is a full-featured PMIC optimized for Microchip MPU devices.

The MCP16502 integrates four DC-DC buck regulators and two auxiliary LDOs, and provides a comprehensive interface to the MPU, which includes an Interrupt flag and an I²C interface.

All buck channels can support loads up to 1A. All bucks are 100% duty cycle capable.

Two 300 mA LDOs are provided such that sensitive analog loads can be supported.

The default power channel sequencing is built-in, according to the requirements of the Microchip MPU device.

The MCP16502 features a low no-load operational quiescent current, and draws less than 10 uA in full shutdown.

Active discharge resistors are provided on each output. All buck channels support safe start-up into pre-biased outputs.

The MCP16502 is available in a 32-pin 5 mm x 5 mm VQFN package with an operating junction temperature range from -40°C to +125°C. It is AEC-Q100 Grade 2 (T_{AMB}=105°C) qualified.

SAMA5D27 Wireless SOM1

Functional Description

Figure 4-3. Power Management Unit Schematic

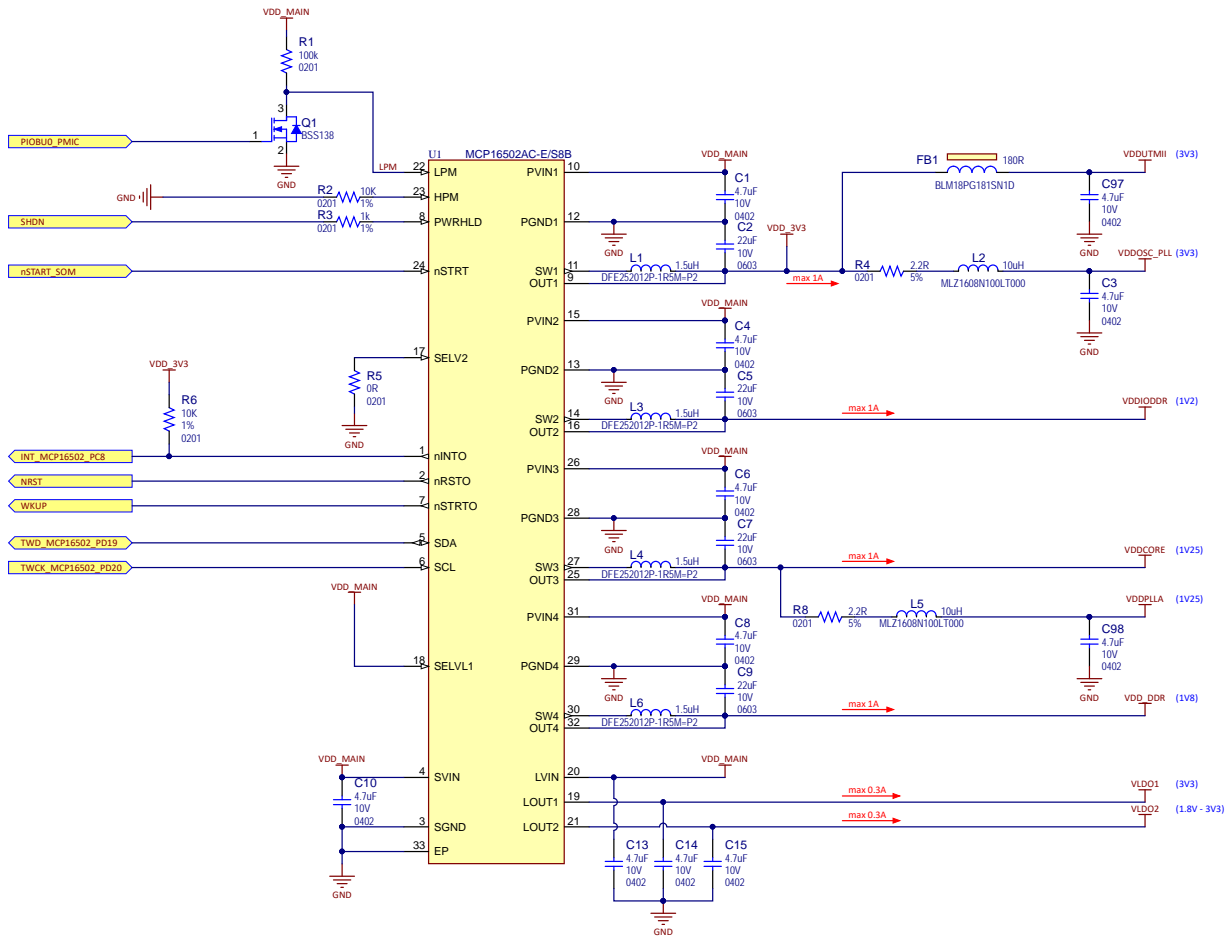

4.1.3 SQI Memory

4.1.3.1 Description and Schematic

The ATSAMA5D27-WLSOM1 embeds the SST26VF064BEUIT-104I/MF, a 64 Mb Serial Quad I/O Flash memory.

The SST26VF064BEUIT-104I/MF SQI features a six-wire, 4-bit I/O interface that allows for low-power, high-performance operation in a low pin-count package.

The SST26VF064BEUIT-104I/MF also embeds EUI-48 and EUI-64 MAC addresses.

The SST26VF064BEUIT-104I/MF is available in 8-lead WDFN package with 6 mm × 5 mm dimensions.

For more information, refer to the [product web page](#).

It is possible to deselect the Chip Enable of the embedded QSPI to use an external one. In this case, the NCS_QSPI pin must be left floating and the signal QSPI1_CS_PB6 must be connected to an external QSPI Chip Select.

SAMA5D27 Wireless SOM1

Functional Description

Figure 4-4. QSPI Memory Schematic

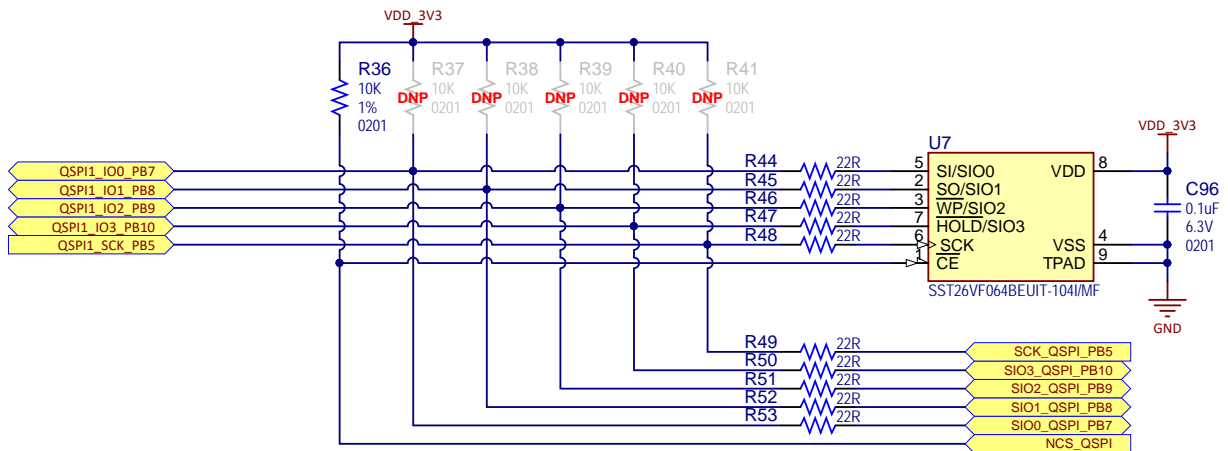

4.1.3.2 MAC Address

The SST26VF064BEUI is pre-programmed at the factory with globally unique EUI-48 and EUI-64 node identifiers. The addresses are located in the Serial Flash Discoverable Parameters (SFDP) table and accessible via the SFDP read instruction.

The 6-byte EUI-48 address value of the SST26VF064BEUI is stored in the SFDP table at address locations 0x261 through 0x266.

The 8-byte EUI-64 address value of the SST26VF064BEUI is stored in the SFDP table at address locations 0x268 through 0x26F.

For more information, refer to the [product web page](#).

4.1.4 Secure Element

The Microchip ATECC608B-TNGTLS is the Trust&GO secure element part of the Trust Platform for the CryptoAuthentication family. The device comes pre-configured and pre-provisioned with default thumbprint certificates and key. The cloud infrastructure, whether it is a public or private network, must accommodate device authentication relying only on the thumbprint certificate from the ATECC608B-TNGTLS. This secure element integrates ECDH (Elliptic Curve Diffie Hellman) security protocol - an ultra-secure method to provide key agreement for encryption/decryption - along with ECDSA (Elliptic Curve Digital Signature Algorithm) sign-verify authentication for the Internet of Things (IoT) market, including home automation, industrial networking, medical, retail or any TLS connected networks.

For more information, refer to the [product web page](#).

Figure 4-5. ECC608B Secure Element Schematic

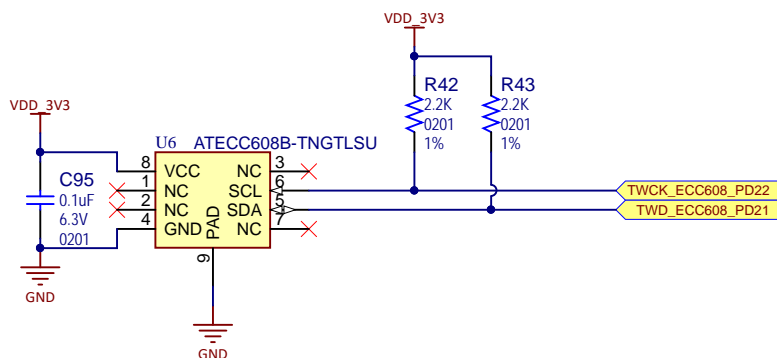

4.2 Power Management

4.2.1 Power Architecture

Basic operation of the ATSAMA5D27-WLSOM1 requires a +5.0V input voltage supply and a VDDBU (+1.65V to +3.6V) input voltage supply, generally ensured by a backup battery. +5.0V power is supplied to the VDD_MAIN domain.

CAUTION As a general design rule, it is recommended to connect all input supply pins, except VDDFUSE which must be connected to GND by a 100 Ohms resistor if not used, to your power supply and at least a matching number of ground (GND) pins. For the best EMI performance, it is recommended to connect ALL ground pins of the ATSAMA5D27-WLSOM1 module to a solid ground plane.

Power-on is controlled through the nSTART_SOM signal. This signal must be provided by the host board; for example, via an automated reset controller or a push-button.

The ATSAMA5D27-WLSOM1 module can operate from a single voltage supply (VDD_MAIN) with a value comprised between +3.0V and +5.5V and, with the MCP16502 PMIC device, internally generates the voltage supplies required by the SAMA5D2 processor and on-board components.

The PMIC on-board switching regulators generate the 3.3V, 1.20V, 1.25V and 1.8V voltage supplies required by the SAMA5D27 processor and on-board components.

The ATSAMA5D27-WLSOM1 delivers external power supplies to the main board application, such as VDD_DDR (1.8V with 900 mA current capability), VDD_3V3 (3.3V with 600mA output current capability) and VLDO2 output (1.8V to 3.3V with 300 mA output current capability).

Figure 4-6. ATSAMA5D27-WLSOM1 Power Architecture

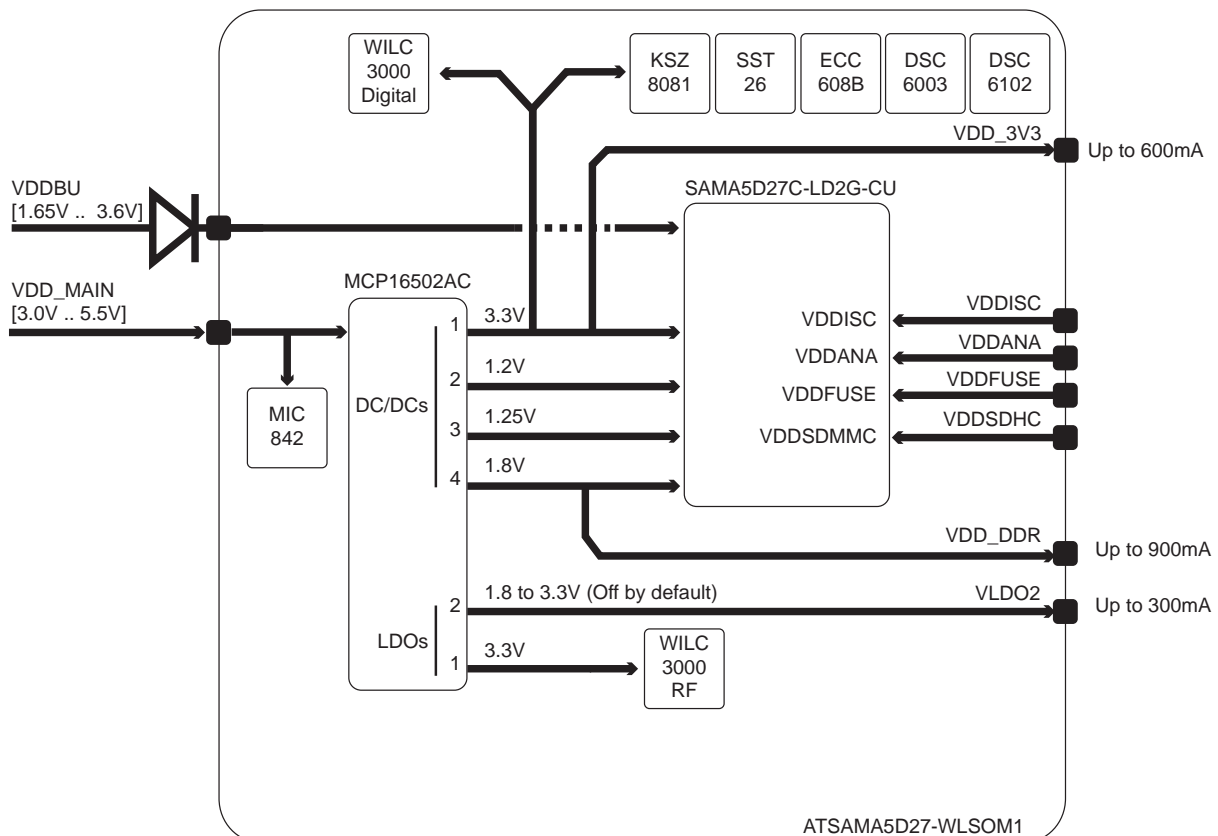

4.2.2 Various Power Configurations

Two different configurations are described below, depending on customer use.

- Single Supply—ATSAMA5D27-WLSOM1 can be supplied by only one input supply (for example, a 5V AC/DC wall adapter) and other input supplies can be connected to the internal 3.3V regulator VDD_3V3. All the PIO lines are supplied at 3.3V.
- Multiple Supplies—ATSAMA5D27-WLSOM1 can be supplied by 5V and by a backup battery. Some PIO lines are supplied by different LDOs for specific applications, such as an ISC camera or a high-speed SD card.

4.2.2.1 Power Configurations: Single Supply

Figure 4-7. ATSAMA5D27-WLSOM1 Single Supply Connection Example

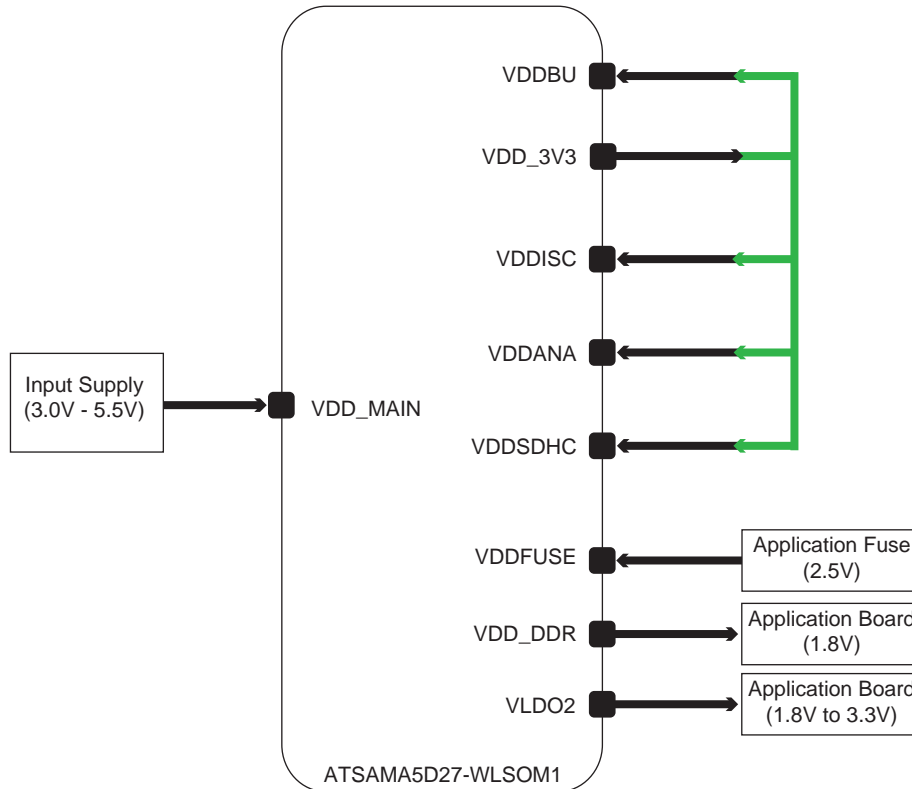

4.2.2.2 Power Configurations: Multiple Supplies

Figure 4-8. ATSAM5D27-WLSOM1 Multiple Supplies Connection Example

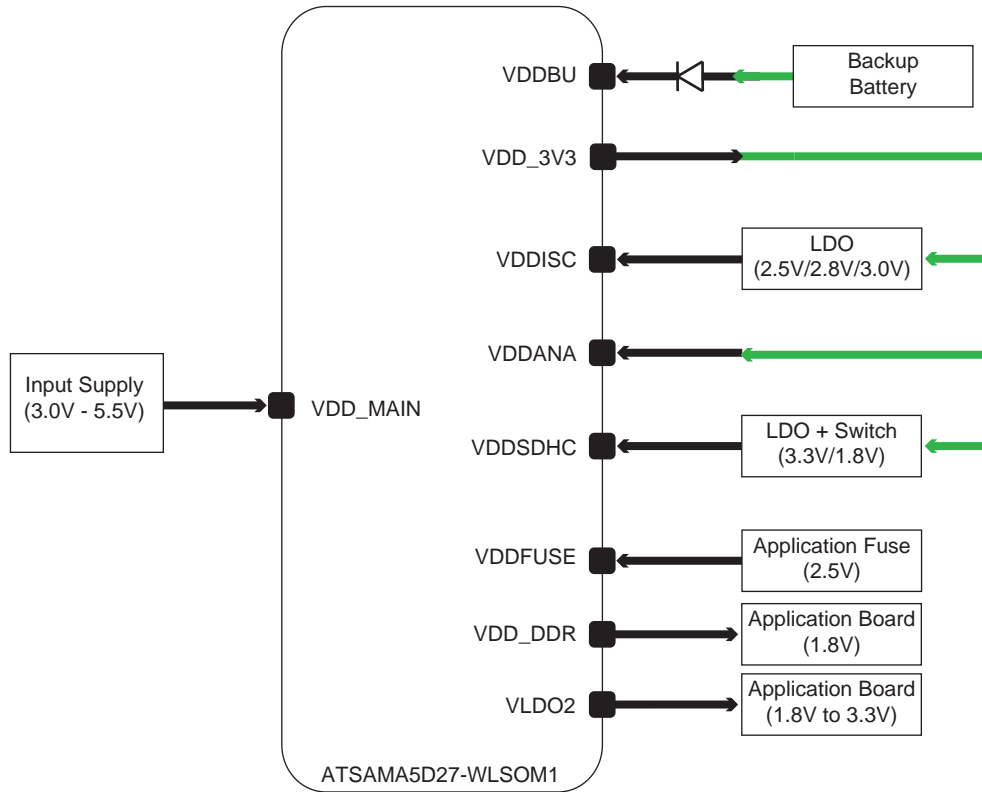

4.2.3 Power On/Off Sequences

4.2.3.1 LPDDR2 Power-Off Sequence

The LPDDR2 power-off sequence must be controlled by software to preserve the LPDDR2 device.

In this sequence, the CKE signal should be low during the full period the power rails are powering down.

The power failure can be controlled by the embedded Voltage Supervisor (MIC842) and handled at system level (IRQ on PD31). The LPDDR2 power-off sequence is applied using the bit LPDDR2_LPDDR3_PWOFF in the MPDDRC Low-Power register (MPDDRC_LPR).

For more information, refer to the following documents:

- SAMA5D2 Series Data sheet available on www.microchip.com/, sections *LPDDR2 Power Fail Management* and *MPDDRC Low-Power Register*
- Jedec Standard *Low Power Double Data Rate 2 (LPDDR2)*, JESD209-2B

Note: An uncontrolled power-off sequence can be applied only up to 400 times in the life of an LPDDR2 device.

SAMA5D27 Wireless SOM1

Functional Description

4.2.3.2 Power ON/OFF Sequences for Single Supply

Figure 4-9. ATSAM5D27-WLSOM1 Single Supply Connection: Power-On Sequence

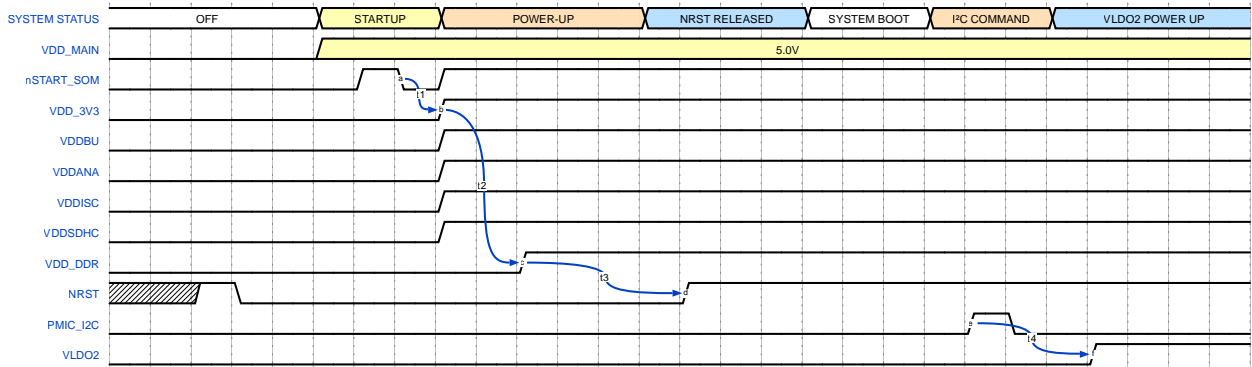

Figure 4-10. ATSAM5D27-WLSOM1 Single Supply Connection: Power-Off Sequence

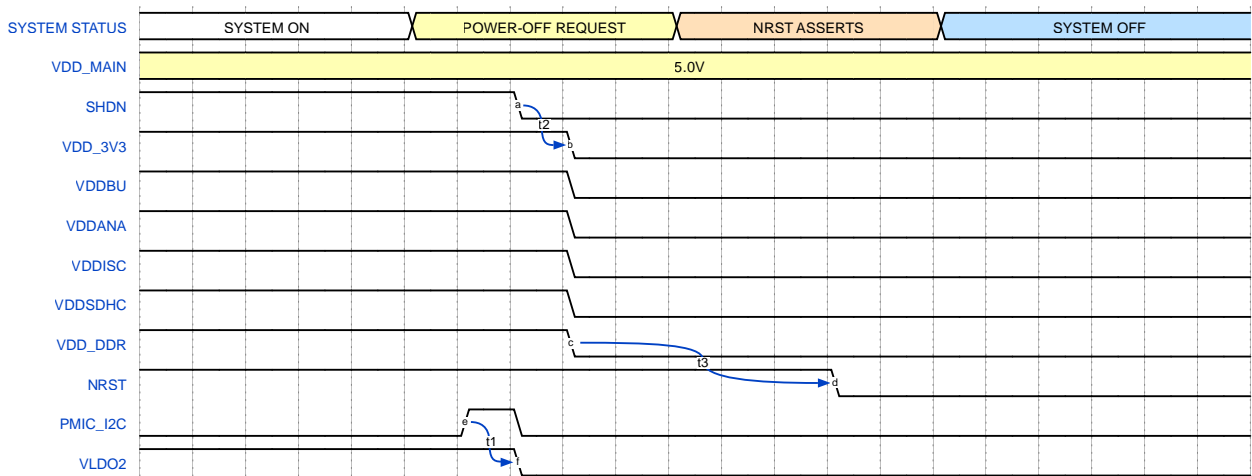

Table 4-1. ATSAM5D27-WLSOM1 Simple Supply Timing Table

Symbol	Description	Min.	Typ.	Max.	Unit
t1	Power-Up Request Timing	0.5	–	2000	ms
t2	VDD_DDR Power-Up Timing	–	8	–	ms
t3	NRST Timing for Release	–	16	–	ms
t4	VLDO2 Power-Up Timing after I ² C Request	–	0.5	1	ms
t5	VLDO2 Power-Down Timing after I ² C Request	–	–	1	ms
t6	VDD_3V3 Power-Down Timing	–	10	–	μs
t7	NRST Forced to Low Timing	–	–	10	μs

SAMA5D27 Wireless SOM1

Functional Description

4.2.3.3 Power ON/OFF Sequences for Multiple Supplies

Figure 4-11. ATSAM5D27-WLSOM1 Multiple Supplies Connections: Power-On Sequence

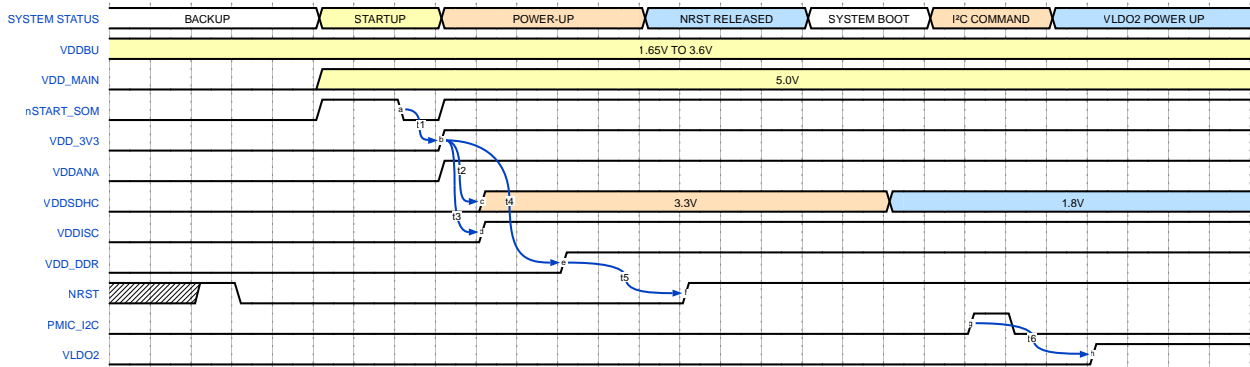

Figure 4-12. ATSAM5D27-WLSOM1 Multiple Supplies Connections: Power-Off Sequence

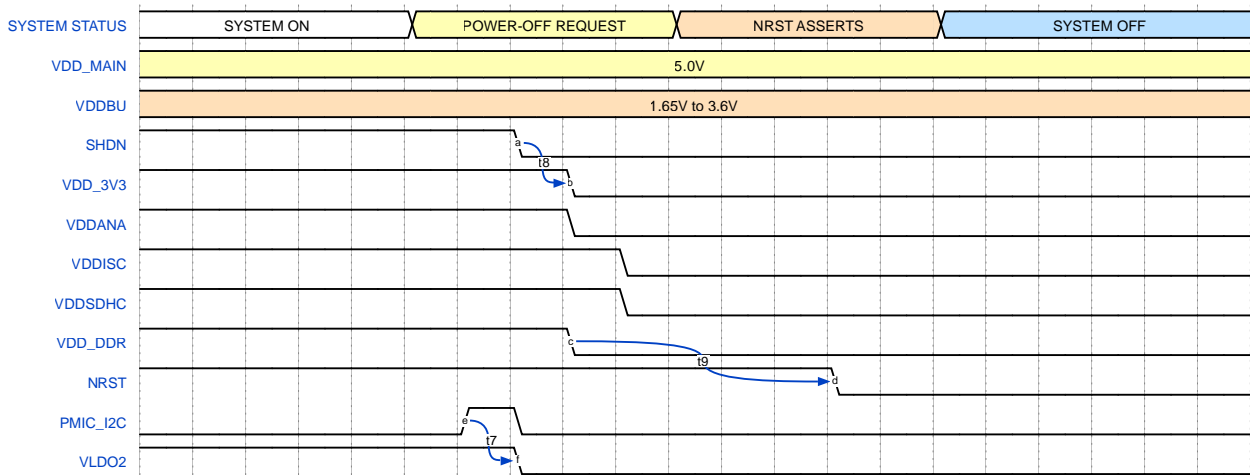

Table 4-2. ATSAM5D27-WLSOM1 Multiple Supplies Timing Table

Symbol	Description	Min.	Typ.	Max.	Unit
t1	Power-Up Request Timing	0.5	–	2000	ms
t2	VDDSDHC Power-Up Timing	–	35	100	µs
t3	VDDISC Power-Up Timing	–	40	100	µs
t4	VDD_DDR Power-Up Timing	–	8	–	ms
t5	NRST Timing for Release	–	16	–	ms
t6	VLDO2 Power-Up Timing after I ² C Request	–	0.5	1	ms
t7	VLDO2 Power-Down Timing after I ² C Request	–	–	1	ms
t8	VDD_3V3 Power-Down Timing	–	10	–	µs
t9	NRST Forced to Low Timing	–	–	10	µs

4.2.4 Baseboard Power Delivery Application Diagram Example

The following figure is an example of power architecture at the baseboard level, input to the SOM and output from the SOM.

SAMA5D27 Wireless SOM1

Functional Description

Figure 4-13. Baseboard Power Delivery Application Diagram Example

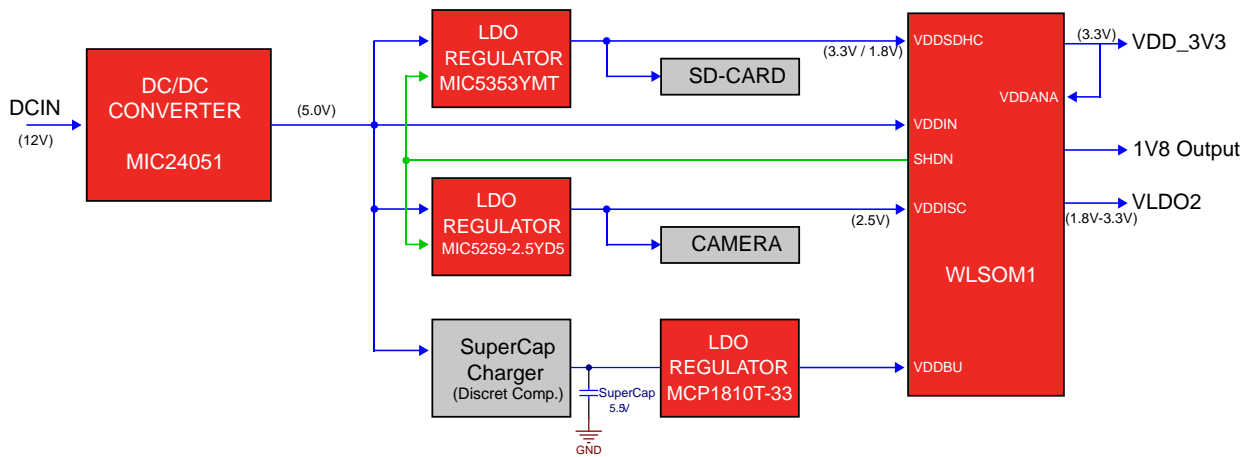

4.3 LAN Subsystem

4.3.1 Ethernet Phy

The Microchip ATSAMA5D27-WLSOM1 embeds a single-supply 10Base-T/100Base-TX Ethernet physical layer transceiver for transmission and reception of data over a standard CAT-5 unshielded twisted pair (UTP) cable.

The KSZ8081RNAIA is a highly-integrated PHY solution. The KSZ8081RNAIA offers the Reduced Media Independent Interface (RMII) for direct connection to RMII-compliant MACs in Ethernet processors.

The KSZ8081RNAIA is available in 24-pin, lead-free QFN packages. For more information, refer to the [product web page](#).

Figure 4-14. Ethernet Phy Schematic

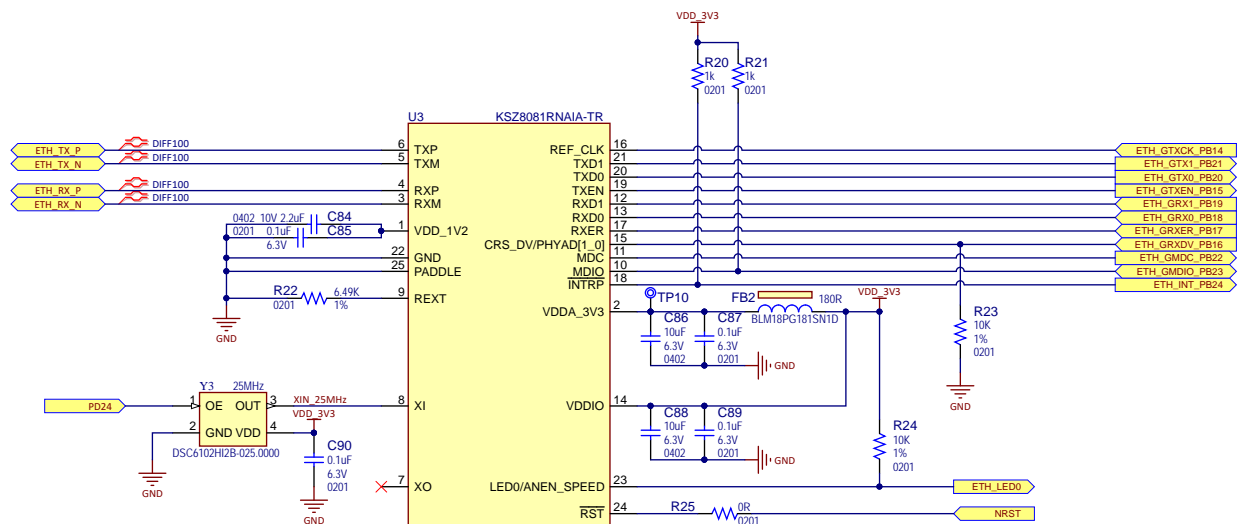

4.3.2 Interfacing with the Ethernet Phy

4.3.2.1 Design Schematic Example

The figure below is a schematic example at main board level.

SAMA5D27 Wireless SOM1

Functional Description

Figure 4-15. Ethernet Phy Schematic Example

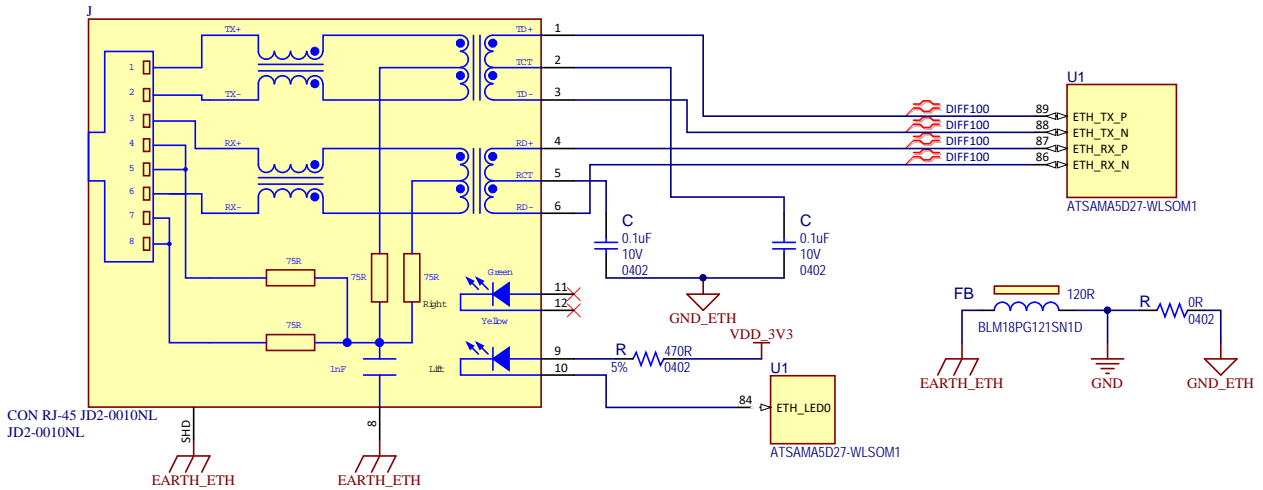

4.3.2.2 Design Layout Recommendations

When designing the Ethernet interface, consider the following recommendations:

- ETH_TX_P, ETH_TX_N, ETH_RX_P and ETH_RX_N should be routed on the top layer without any vias. Traces must be straight.
- ETH_TX_P and ETH_TX_N should be matched in length to within 120 mils.
- ETH_RX_P and ETH_RX_N should be matched in length to within 120 mils.
- ETH_TX_x and ETH_RX_x must be symmetric.
- Place the TX_P and TX_N signals at least 2 times the trace width away from other signals for noise immunity.
- Place signals at least 2 times the trace width away from any copper plan.
- Place the TX and RX signals at least 5 times the trace width away from other signals for noise immunity.
- Check that the ETH_TX_x and ETH_RX_x line impedance is the same for all signal layers. Recommended differential impedance for net: $100\Omega \pm 5\%$.

4.3.2.3 Design Layout Example

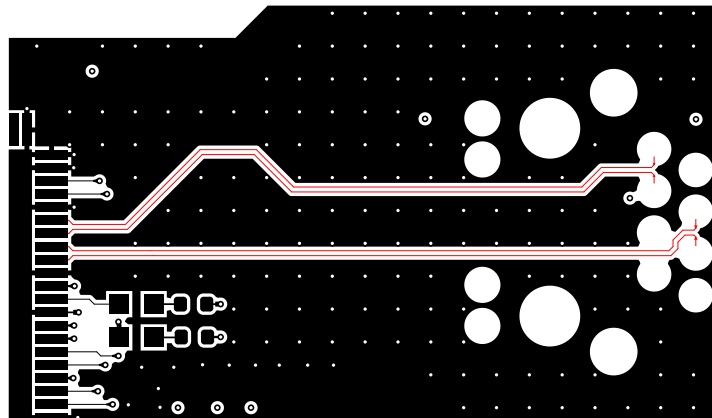

4.4 Voltage Threshold Detector

The Microchip ATSAM5D27-WLSOM1 embeds a MIC842 micro-power, precision-voltage comparator with an on-chip voltage reference.

The device is intended for voltage monitoring applications. External resistors are used to set the voltage monitor threshold. When the threshold is crossed, the outputs switch polarity. Refer to the figures below.

SAMA5D27 Wireless SOM1

Functional Description

The MIC842 incorporates a voltage reference and comparator with fixed internal hysteresis; two external resistors are used to set the switching threshold voltage.

Supply current is extremely low (1.5 μ A, typical), making it ideal for portable applications.

The MIC842 is supplied in 4-pin 1.2 mm \times 1.6 mm Thin DFN package. For more information, refer to the [product web page](#).

Figure 4-16. Voltage Threshold Detector Schematic

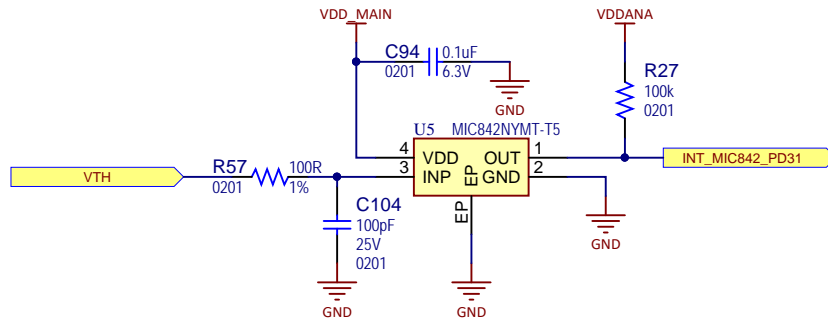

Figure 4-17. Voltage Threshold Detector Implementation Example

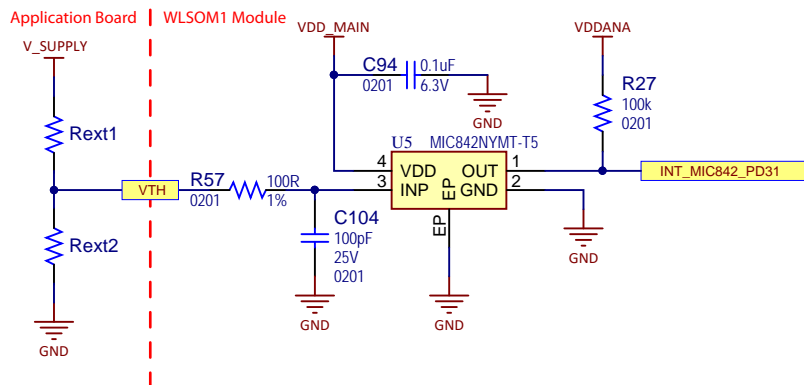

Table 4-3. Output Resistor Ladder Values and Input System Supply Example

System Supply Voltage	Threshold Detection Value	Rext1 Value	Rext2 Value
5V	4.64V	787 k Ω	287 k Ω
12V	11V	787 k Ω	100 k Ω
24V	21.78V	787 k Ω	47.5 k Ω
48V	39.51V	787 k Ω	25.5 k Ω

4.5 Radio Subsystem

The ATWILC3000-MR110UA module, which uses a single chip IEEE 802.11 b/g/n RF/Baseband/MAC link controller and Bluetooth 5. The ATWILC3000 connects to Microchip MPUs, with minimal resource requirements with simple SDIO-to-Wi-Fi and UART-to-Bluetooth interfaces.

The ATWILC3000-MR110UA supports single stream 1x1 802.11n mode, providing tested throughput of up to 46 Mbps UDP & 28 Mbps TCP/IP. The ATWILC3000-MR110UA features fully integrated power amplifier, LNA, switch and power management. Implemented in low-power CMOS technology, the ATWILC3000-MR110UA offers very low power consumption while simultaneously providing high performance and minimal bill of materials.

SAMA5D27 Wireless SOM1

Functional Description

The ATWILC3000-MR110UA utilizes highly -optimized 802.11 Bluetooth coexistence protocols. The only external clock sources needed are a high-speed crystal or oscillator and a 32.768 kHz clock for sleep operation. In the ATWILC3000-MR110UA, the 32.768 kHz clock is provided by the ATWILC3000-MR110UA through PB13.

For more information, refer to the [product web page](#).

Figure 4-18. Wi-Fi/BT Radio Subsystem Schematic

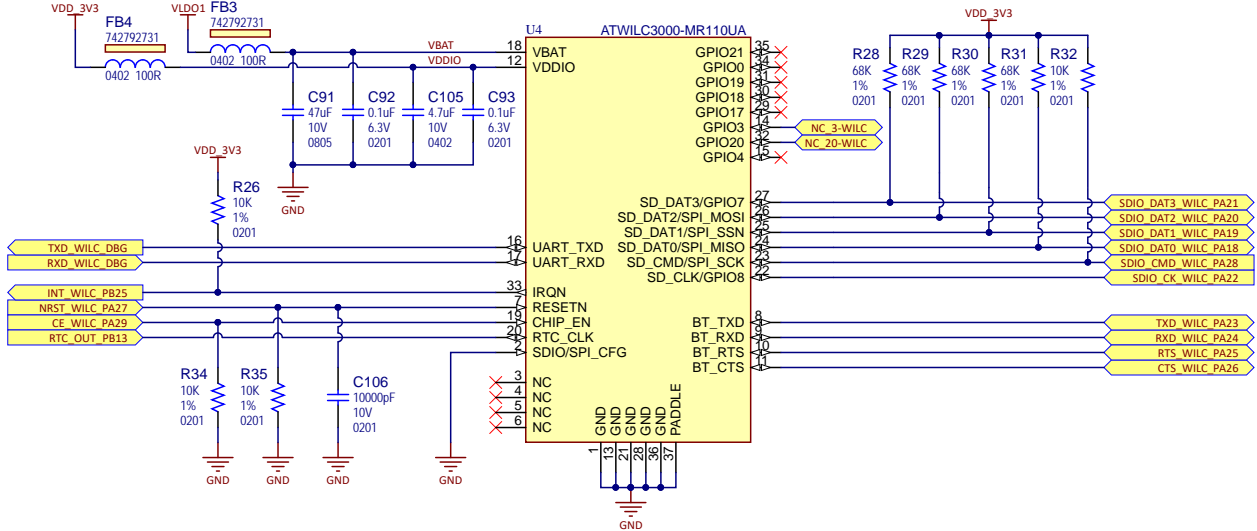

4.6 External Interfaces

4.6.1 Interfacing with an SD Card

The SD (Secure Digital) Card is a nonvolatile memory card format used as mass storage memory in mobile devices.

Secure Digital Multimedia Card (SDMMC) Controller

The ATWILC3000-MR110UA has one Secure Digital Multimedia Card (SDMMC) interface that supports the MultiMedia Card (eMMC) Specification V4.41, the SD Memory Card Specification V3.0, and the SDIO V3.0 specification. It is compliant with the SD Host Controller Standard V3.0 specification.

The SDMMC0 interface can be connected to a standard SD card interface.

SDMMC0 Card Connector

The board features a standard MMC/SD card connector, connected to SDMMC0. The SDMMC0 communication is based on a 4- or 8-pin interface (clock, command, four or eight data and power lines). It may include a card detection switch.

4.6.1.1 Design Schematic Examples

The figures below illustrate the implementation for the SDMMC0 interface for a 4-bit interface and for an 8-bit interface with a power switch for the supply of the digital interface for high-speed interface management.

SAMA5D27 Wireless SOM1

Functional Description

Figure 4-19. 4-bit/8-bit SD Card Power Switch Example Schematic

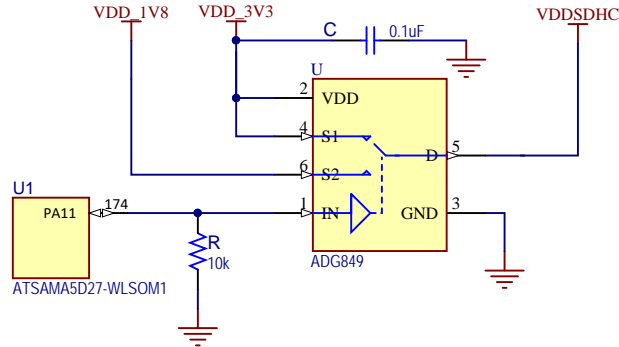
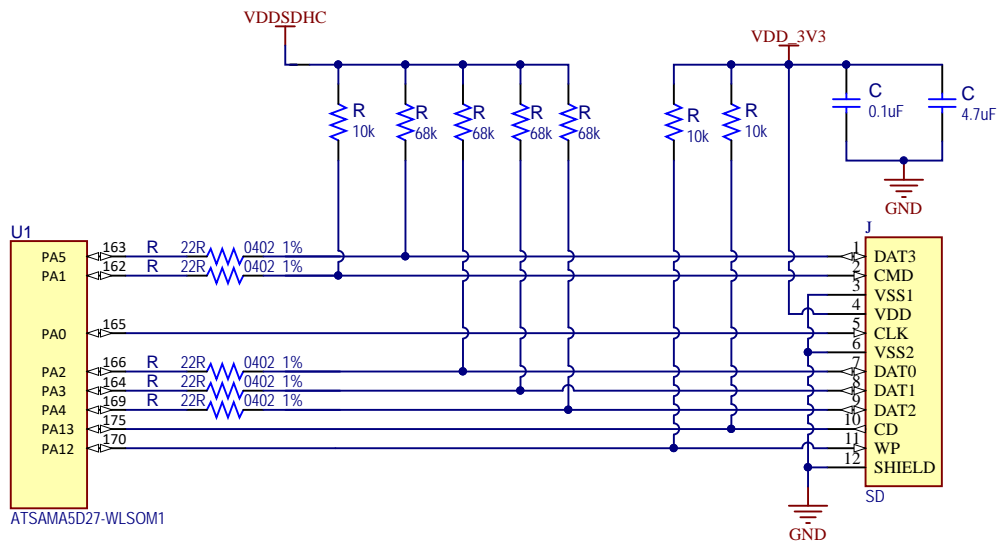

Figure 4-20. 4-bit SD Card Interface Example Schematic



SAMA5D27 Wireless SOM1

Functional Description

Figure 4-21. 8-bit SD Card Interface Example Schematic

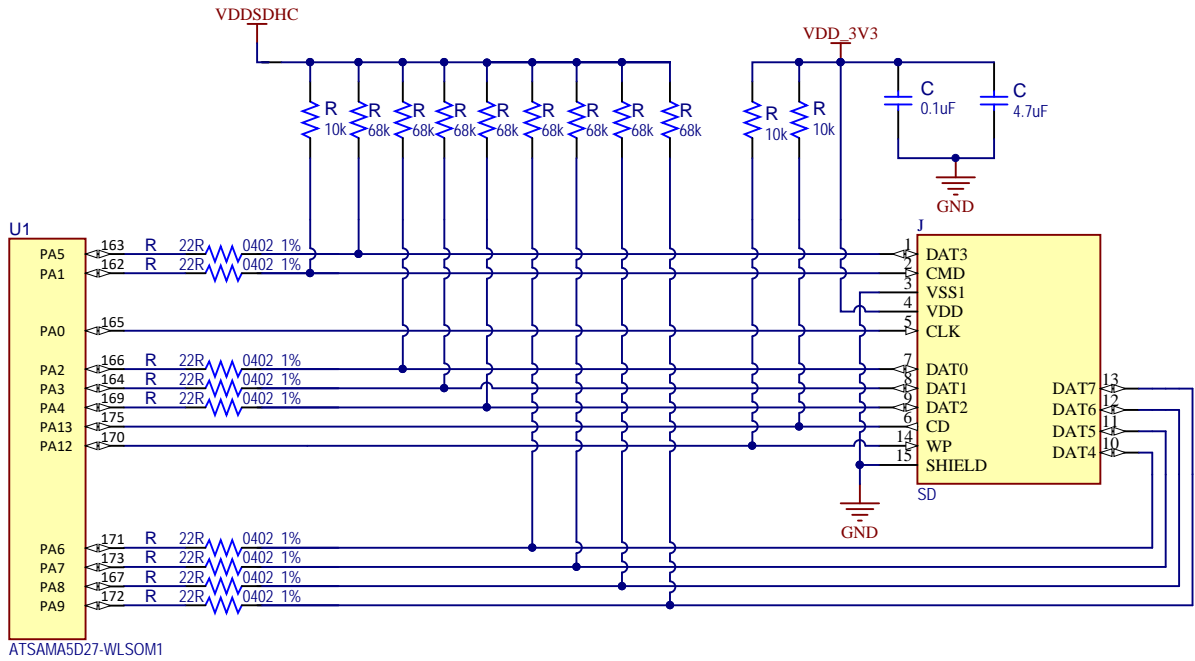

4.6.1.2 Design Layout Recommendations

When designing the SD Card interface, consider the following recommendations:

- Match signal lengths to within 50 mils. Affected PIOs in the example above are PA0 to PA5.
- Place the clock line (PA0) at least 3 times the trace width away from other signals for noise immunity.
- Apply impedance control of 50 Ohms on the clock and data interfaces.
- Place data signals at least 2 times the trace width away from any other data traces.
- Place data signals at least 1 trace width away from any copper plan.

Figure 4-22. SD Card Layout Example

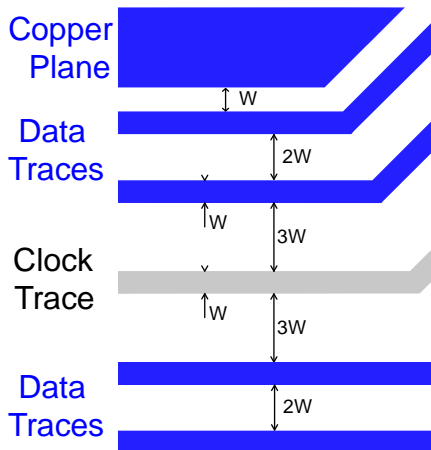

4.6.1.3 EMI Improvement Recommendations

To reduce radiation emission, consider the following recommendations:

- Position all the signals of the SD Card interface in inner layers of the PCB.
- Place the resistors as close as possible to the WLSOM1 module.

Figure 4-23. EMI Improvement Layout Example

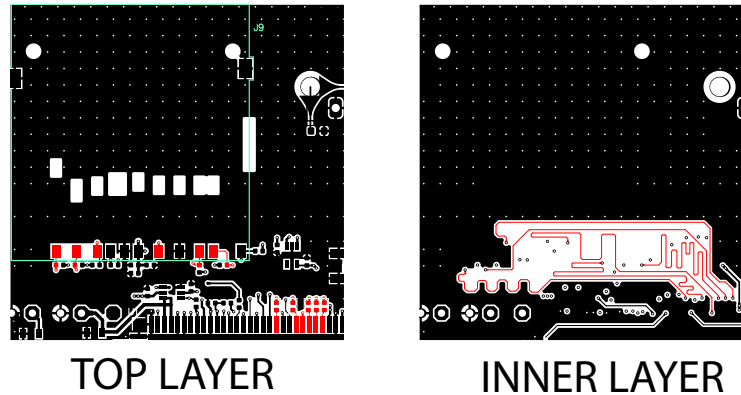

4.6.2 Interfacing with e-MMC

The Secure Digital Multimedia Card (SDMMC) Controller supports the Embedded MultiMedia Card (e-MMC) Specification V4.41, the SD Memory Card Specification V3.0, and the SDIO V3.0 specification. It is compliant with the SD Host Controller Standard V3.0 specification.

Table 4-4. SDMMC Reference Documents

Name	Link
SD Host Controller Simplified Specification V3.00	www.sdcard.org
SDIO Simplified Specification V3.00	www.sdcard.org
Physical Layer Simplified Specification V3.01	www.sdcard.org
Embedded MultiMedia Card (e-MMC) Electrical Standard 4.51	www.jedec.org

4.6.2.1 Design Schematic Example

In the example below, one MTFC4GLDEA 4 GB e-MMC is connected to the processor through the SDMMC0 port.

Figure 4-24. e-MMC Power Switch Example Schematic

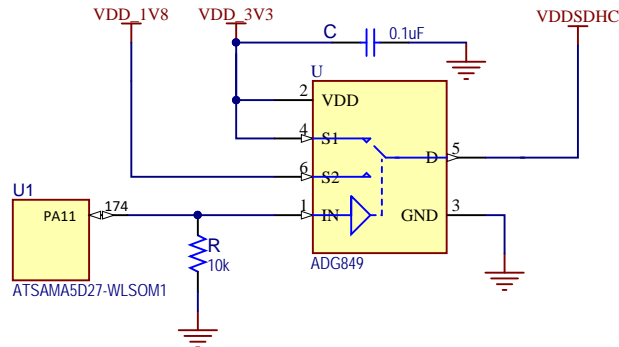

SAMA5D27 Wireless SOM1

Functional Description

Figure 4-25. e-MMC Interface Example Schematic

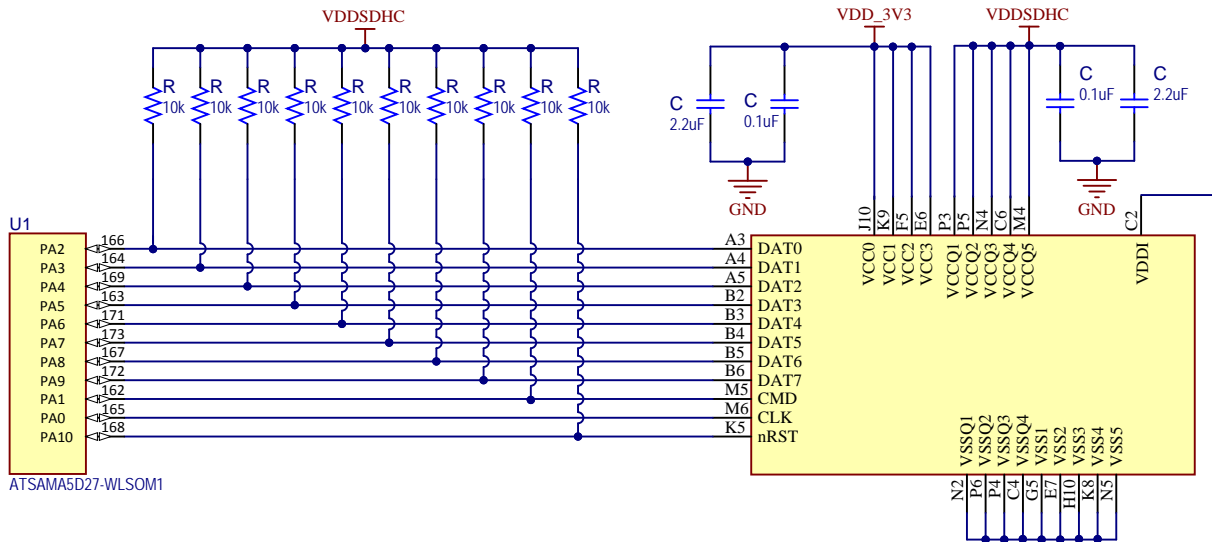

4.6.2.2 Design Layout Recommendations

When designing the e-MMC interface, consider the following recommendations:

- Match signal lengths to within 50 mils. Affected PIOs in the example above are PA0 to PA9.
- Place the clock line (PA0) at least 3 times the trace width away from other signals for noise immunity.
- Place data signals at least 2 times the trace width away from any other data trace.
- Place data signals at least 1 trace width away from any copper plan.

Figure 4-26. e-MMC Layout Example

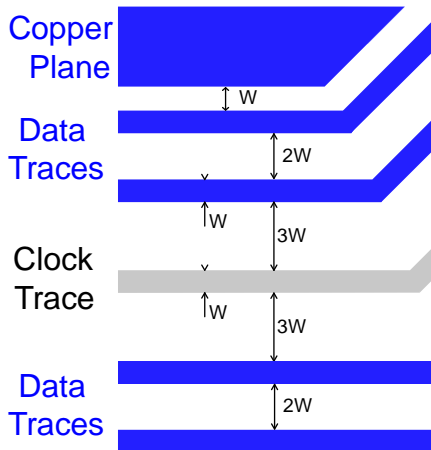

4.6.3 Interfacing with NAND Flash

This Static Memory Controller (SMC) is capable of handling several types of external memory and peripheral devices, such as SRAM, PSRAM, PROM, EPROM, EEPROM, LCD module, NOR Flash and NAND Flash.

The SMC generates the signals that control the access to external memory devices or peripheral devices.

The SMC embeds a NAND Flash Controller (NFC). The NFC can handle automatic transfers, sending the commands and address cycles to the NAND Flash and transferring the contents of the page (for read and write) to the NFC SRAM. It minimizes the CPU overhead.

The SMC includes programmable hardware error correcting code with one-bit error correction capability and supports two-bit error detection.

SAMA5D27 Wireless SOM1

Functional Description

In order to improve the overall system performance, the DATA phase of the transfer can be DMA-assisted.

4.6.3.1 Design Schematic Example

The example below is given with an 8-bit NAND Flash memory from Micron.

Figure 4-27. NAND Flash Interface Example Schematic

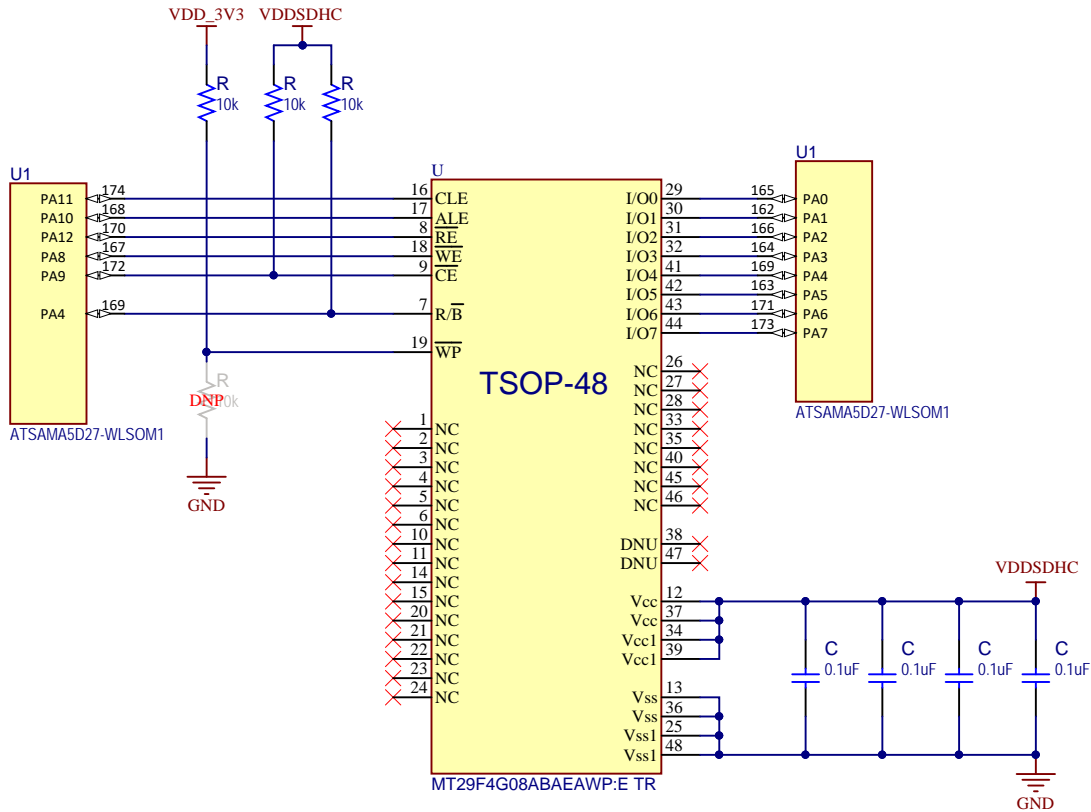

4.6.3.2 Design Layout Recommendations

When designing the NAND Flash interface, consider the following recommendations:

- Match signal lengths to within 50 mils. Affected PIOs in the example schematic above are PA0 to PA7. For EMI improvement, all these nets should be placed in inner layers.
- Place data signals at least 2 times the trace width away from any other data trace.
- Place data signals at least 1 trace width away from any copper plan.

Figure 4-28. NAND Flash Layout Example

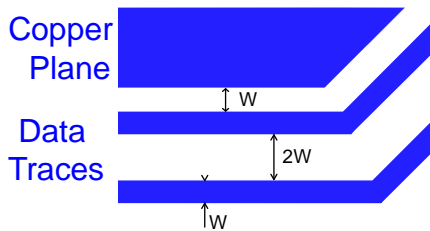

4.6.4 Interfacing with an Image Sensor Controller (ISC)

The Image Sensor Controller (ISC) system manages incoming data from a parallel sensor. It supports a single active interface. The parallel interface protocol can use a free-running clock or a gated clock strategy. It supports the ITU-R BT 656/1120 422 protocol with a data width of 8 bits or 10 bits and raw Bayer format. The internal image processor includes adjustable white balance, color filter array interpolation, color correction, gamma correction, 12-bit to 10-bit

SAMA5D27 Wireless SOM1

Functional Description

compression, programmable color space conversion and horizontal and vertical chrominance subsampling module. The module also integrates a triple channel Direct Memory Access Controller host interface.

4.6.4.1 Design Schematic Example

The example schematics shown below are for different Image Sensor supply voltages.

Figure 4-29. Camera Interface Example Schematic with VDDISC Set at 3.3V

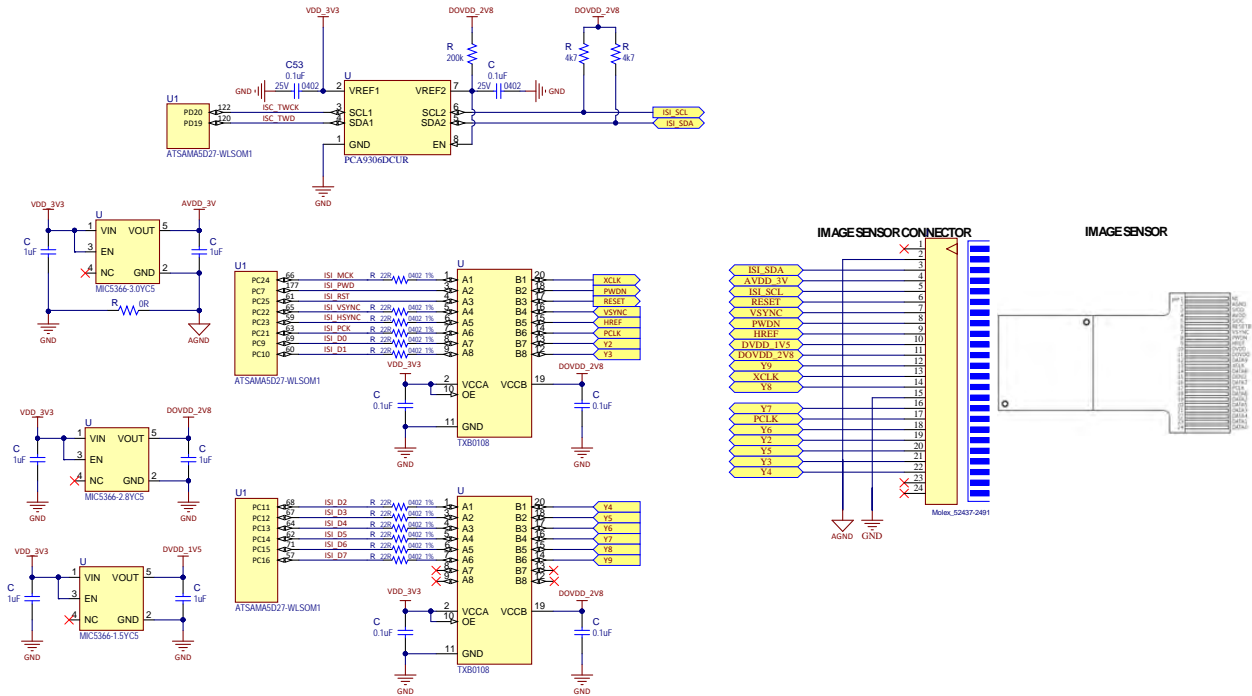
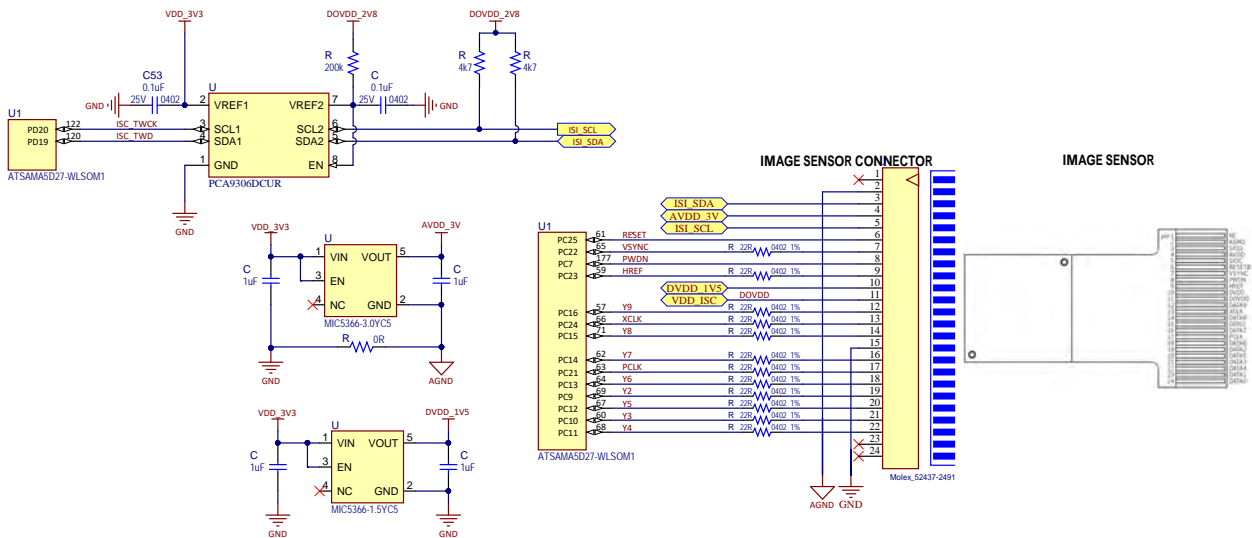

Figure 4-30. Camera Interface Example Schematic with VDDISC Set at Specific Voltage



4.6.4.2 Design Layout Recommendations

When designing the ISC interface, consider the following recommendations:

- Match signal lengths to within 50 mils. Affected PIOs in the example above are PC9 to PC24.
- Place the clock lines (PC21 and PC24) at least 3 times the trace width away from other signals for noise immunity.
- Place data signals at least 2 times the trace width away from any other data traces.

- Place data signals at least 2 times the trace width away from any copper plan.

Figure 4-31. ISC Layout Example

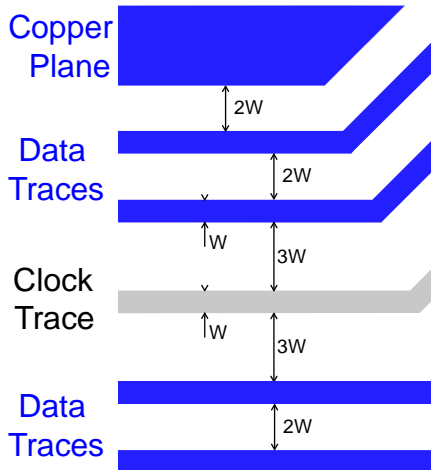

4.6.4.3 EMI Improvement Recommendations

To reduce radiation emission, consider the following recommendations:

- Position the ISC bus interface in inner layers of the PCB.
- Add a ferrite bead on PCLK and on XCLK clocks lines.
- Add a ferrite bead on the camera power supply.
- Select a shielded camera connector.

Figure 4-32. EMI Improvement Example

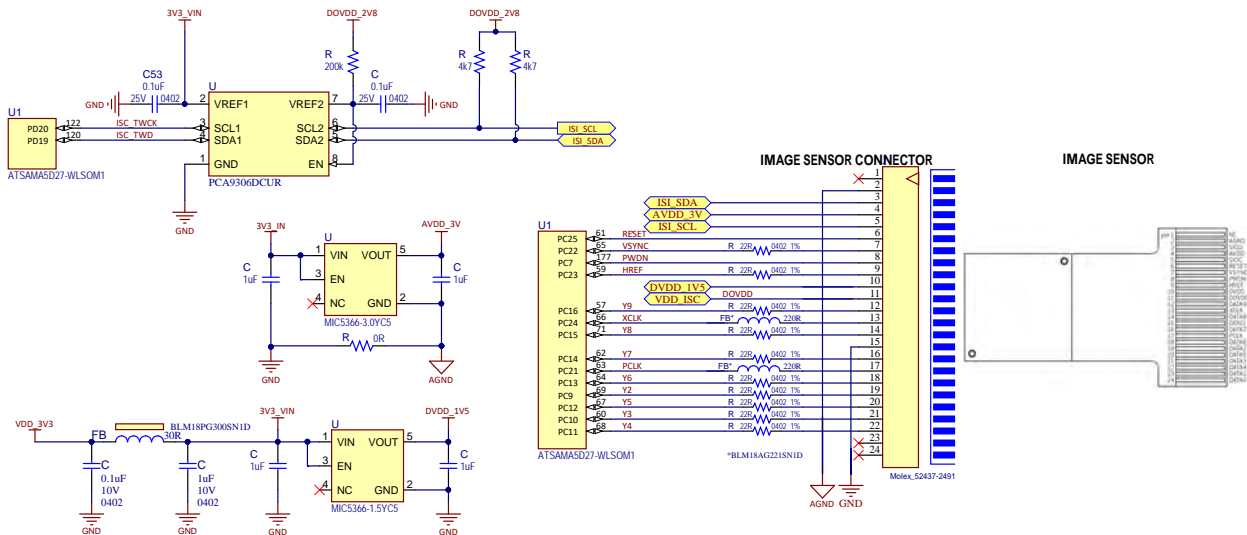

4.6.5 Connecting to the SPI Interface

Four different FLEXCOM interfaces, with seven possible configurations (configured in SPI mode), and two pure SPI Interfaces, with four possible configurations, are available on the ATSA5D27-WLSOM1 module.

The Flexible Serial Communication Controller (FLEXCOM) offers several serial communication protocols that are managed by the three submodules USART, SPI, and TWI.

The Serial Peripheral Interface (SPI) circuit is a synchronous serial data link that provides communication with external devices in Host or Client mode. It also enables communication between processors if an external processor is connected to the system.

SAMA5D27 Wireless SOM1

Functional Description

The Serial Peripheral Interface is essentially a shift register that serially transmits data bits to other SPI devices. During a data transfer, one SPI system acts as the “host” which controls the data flow, while the other devices act as “clients” which have data shifted into and out by the host. Different CPUs can take turn being hosts (multiple host protocol, contrary to single host protocol where one CPU is always the host while all of the others are always clients). One host can simultaneously shift data into multiple clients. However, only one client can drive its output to write data back to the host at any given time.

A client device is selected when the host asserts its NSS signal. If multiple client devices exist, the host generates a separate client select signal for each client (NPCS).

The SPI system consists of two data lines and two control lines:

- Host Out Client In (MOSI)—This data line supplies the output data from the host shifted into the input(s) of the client(s).
- Host In Client Out (MISO)—This data line supplies the output data from a client to the input of the host. There may be no more than one client transmitting data during any particular transfer.
- Serial Clock (SPCK)—This control line is driven by the host and regulates the flow of the data bits. The host can transmit data at a variety of baud rates; there is one SPCK pulse for each bit that is transmitted.
- Client Select (NSS)—This control line allows clients to be turned on and off by hardware.

Table 4-5. SPI Interface Configurations

Interface Instance	IO set	Pin #	PIO	Pin Name	Comments
SPI0	1	21	PA14	SPI0_SPCK	
SPI0	1	22	PA15	SPI0_MOSI	
SPI0	1	23	PA16	SPI0_MISO	
SPI0	1	24	PA17	SPI0_NPCS0	
SPI0	2	76	PA30	SPI0_NPCS0	
SPI0	2	75	PA31	SPI0_MISO	
SPI0	2	81	PB00	SPI0_MOSI	
SPI0	2	80	PB01	SPI0_SPCK	
SPI0	1	18	PC01	SPI1_SPCK	
SPI1	1	17	PC02	SPI1_MOSI	
SPI1	1	16	PC03	SPI1_MISO	
SPI1	1	19	PC04	SPI1_NPCS0	
SPI1	1	20	PC05	SPI1_NPCS1	
SPI1	1	176	PC06	SPI1_NPCS2	
SPI1	1	177	PC07	SPI1_NPCS3	
SPI1	3	132	PD25	SPI1_SPCK	
SPI1	3	127	PD26	SPI1_MOSI	
SPI1	3	123	PD27	SPI1_MISO	
SPI1	3	124	PD28	SPI1_NPCS0	
SPI1	3	131	PD29	SPI1_NPCS1	
SPI1	3	130	PD30	SPI1_NPCS2	

SAMA5D27 Wireless SOM1

Functional Description

Table 4-6. FLEXCOM Interfaces Configurations in SPI Mode

Interface Instance	IO set	Pin #	PIO	Pin Name	Comments
FLEXCOM0	1	28	PB28	FLEXCOM0_IO0	MOSI Signal
FLEXCOM0	1	27	PB29	FLEXCOM0_IO1	MISO Signal
FLEXCOM0	1	30	PB30	FLEXCOM0_IO2	SPCK Signal
FLEXCOM0	1	26	PB31	FLEXCOM0_IO3	NPCS0 Signal
FLEXCOM0	1	15	PC00	FLEXCOM0_IO4	NPCS1 Signal
FLEXCOM2	1	171	PA06	FLEXCOM2_IO0	MOSI Signal
FLEXCOM2	1	173	PA07	FLEXCOM2_IO1	MISO Signal
FLEXCOM2	1	167	PA08	FLEXCOM2_IO2	SPCK Signal
FLEXCOM2	1	172	PA09	FLEXCOM2_IO3	NPCS0 Signal
FLEXCOM2	1	168	PA10	FLEXCOM2_IO4	NPCS1 Signal
FLEXCOM2	2	127	PD26	FLEXCOM2_IO0	MOSI Signal
FLEXCOM2	2	123	PD27	FLEXCOM2_IO1	MISO Signal
FLEXCOM2	2	124	PD28	FLEXCOM2_IO2	SPCK Signal
FLEXCOM2	2	131	PD29	FLEXCOM2_IO3	NPCS0 Signal
FLEXCOM2	2	130	PD30	FLEXCOM2_IO4	NPCS1 Signal
FLEXCOM3	2	56	PC18	FLEXCOM3_IO2	SPCK Signal
FLEXCOM3	2	70	PC19	FLEXCOM3_IO1	MISO Signal
FLEXCOM3	2	58	PC20	FLEXCOM3_IO0	MOSI Signal
FLEXCOM3	2	63	PC21	FLEXCOM3_IO3	NPCS0 Signal
FLEXCOM3	2	65	PC22	FLEXCOM3_IO4	NPCS1 Signal
FLEXCOM4	1	39	PC28	FLEXCOM4_IO0	MOSI Signal
FLEXCOM4	1	38	PC29	FLEXCOM4_IO1	MISO Signal
FLEXCOM4	1	34	PC30	FLEXCOM4_IO2	SPCK Signal
FLEXCOM4	1	36	PC31	FLEXCOM4_IO3	NPCS0 Signal
FLEXCOM4	1	33	PD00	FLEXCOM4_IO4	NPCS1 Signal
FLEXCOM4	2	119	PD12	FLEXCOM4_IO0	MOSI Signal
FLEXCOM4	2	116	PD13	FLEXCOM4_IO1	MISO Signal
FLEXCOM4	2	117	PD14	FLEXCOM4_IO2	SPCK Signal
FLEXCOM4	2	114	PD15	FLEXCOM4_IO3	NPCS0 Signal
FLEXCOM4	2	115	PD16	FLEXCOM4_IO4	NPCS1 Signal

4.6.6 Connecting to the I²C Interface

Four different FLEXCOM interfaces, with seven possible configurations (configured in TWI mode), and one pure TWI Interface are available on the ATSAMA5D27-WLSOM1 module.

The Flexible Serial Communication Controller (FLEXCOM) offers several serial communication protocols that are managed by the three submodules USART, SPI, and TWI.

SAMA5D27 Wireless SOM1

Functional Description

The Two-wire Interface (TWI) interconnects components on a unique two-wire bus, made up of one clock line and one data line with speeds of up to 400 kbit/s in Fast mode and up to 3.4 Mbit/s in High-Speed Client mode only, based on a byte-oriented transfer format.

It can be used with any Two-wire Interface bus Serial EEPROM and I²C-compatible devices, such as a Real-Time Clock (RTC), Dot Matrix/Graphic LCD Controller and temperature sensor. The TWI is programmable as a host or a client with sequential or single-byte access. Multiple host capability is supported.

Table 4-7. I²C Interface Configurations

Interface Instance	IO Set	Pin #	PIO	Pin Name	Comment
TWI1	3	120	PD19	TWD1	No need of external pull-up. Already integrated in ATSAMA5D27-WLSOM1 module
TWI1	3	122	PD20	TWCK1	
FLEXCOM0	1	28	PB28	FLEXCOM0_IO0	Need external pull-up in case the FLEXCOM interface is used as an I ² C/TWI interface.
FLEXCOM0	1	27	PB29	FLEXCOM0_IO1	
FLEXCOM2	1	171	PA6	FLEXCOM2_IO0	
FLEXCOM2	1	173	PA7	FLEXCOM2_IO1	
FLEXCOM2	2	127	PD26	FLEXCOM2_IO0	
FLEXCOM2	2	123	PD27	FLEXCOM2_IO1	
FLEXCOM3	1	22	PA15	FLEXCOM3_IO0	
FLEXCOM3	1	175	PA13	FLEXCOM3_IO1	
FLEXCOM3	2	58	PC20	FLEXCOM3_IO0	
FLEXCOM3	2	63	PC21	FLEXCOM3_IO1	
FLEXCOM4	1	39	PC28	FLEXCOM4_IO0	
FLEXCOM4	1	38	PC29	FLEXCOM4_IO1	
FLEXCOM4	2	119	PD12	FLEXCOM4_IO0	
FLEXCOM4	2	116	PD13	FLEXCOM4_IO1	

4.6.7 Interfacing with CLASS-D Audio Output

The Audio Class D Amplifier (CLASSD) is a digital input, pulse width modulated (PWM) output mono Class D amplifier. It features a high-quality interpolation filter embedding a digitally controlled gain, an equalizer and a de-emphasis filter.

On its input side, the CLASSD is compatible with most common audio data rates. On the output side, its PWM output can drive either:

- high-impedance single-ended or differential output loads (Audio DAC application) or,
- external MOSFETs through an integrated nonoverlapping circuit (Class D power amplifier application).

SAMA5D27 Wireless SOM1

Functional Description

Figure 4-33. CLASS-D Interface Example Schematic

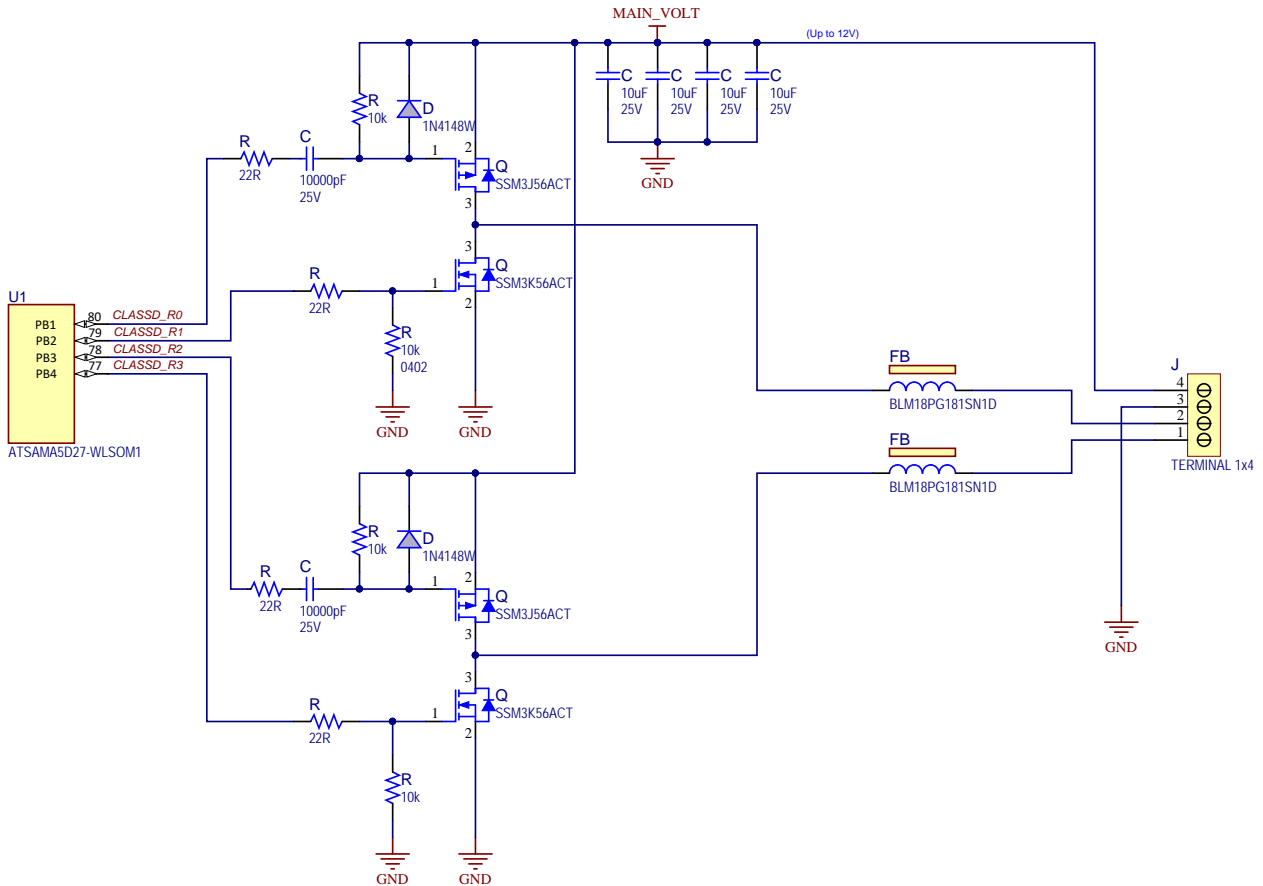

4.6.8 QTouch® Peripheral Touch Controller (PTC)

For details on implementing the PTC, refer to the documents listed below:

Title	Document Type	Literature Number
QTAN0079 – Buttons, Sliders and Wheels Sensor Design Guide	Design Guide	10752
AN_2585: Implementing a QTouch PTC Subsystem on SAMA5D2 MPU	Application Note	DS000002585
AN_2472: QTouch on SAMA5D2 MPU	Application Note	DS000002472

4.6.9 Interfacing with an LCD

4.6.9.1 Design Schematic Example

The ATSAM5D27-WLSOM1 features an 18-bit RGB LCD interface.

The figure below is a schematic example at main board level illustrating the interface with the [AC32005](#) Microchip display module (WVGA LCD display module with maXTouch® technology).

In this example, several interfaces are used:

- LCD_XXX signals for display
- one SPI interface for display configuration
- one TWI interface for maXTouch and QTouch device control
- two IRQ I/Os for capacitive touch and buttons interruption

SAMA5D27 Wireless SOM1

Functional Description

Figure 4-34. LCD Schematic Example

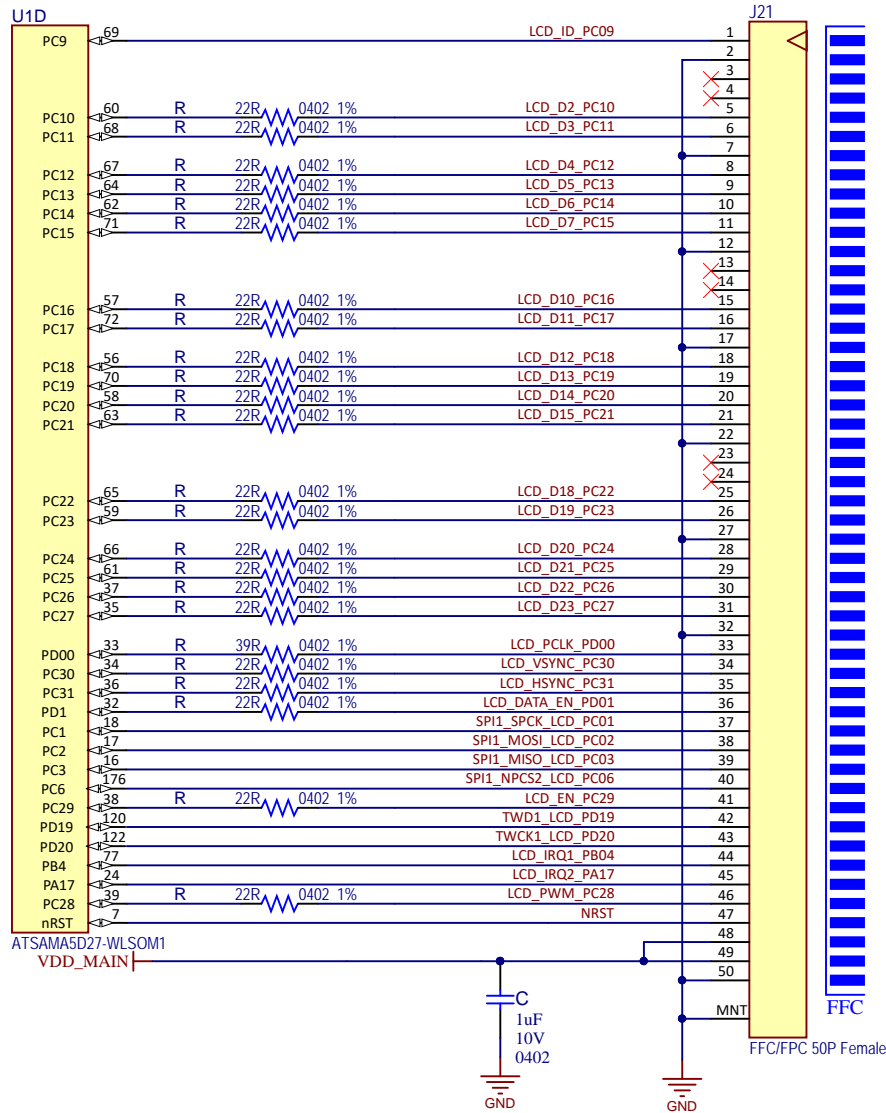

4.6.9.2 Design Layout Recommendations

When designing the LCD interface, consider the following recommendations:

- Match the LCD signal lengths to within 50 mils. Affected PIOs in the example above are PC10 to PC27, PC30, PC31, PD0 and PD1.
- Place the clock line (PD0) at least 3 times the trace width away from other signals for noise immunity.
- Place data signals at least 2 times the trace width away from any other data trace.
- Design data signals at least 2 times the trace width away from any copper plan.

Figure 4-35. LCD Layout Example

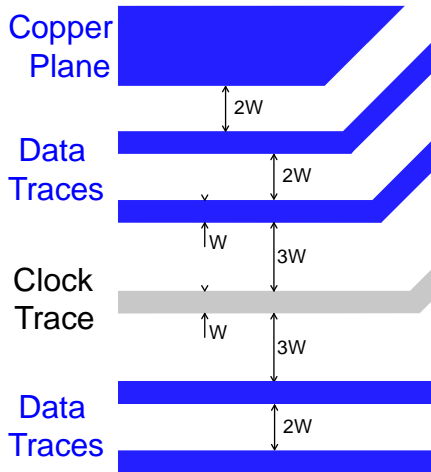

4.6.9.3 EMI Improvement Recommendations

To reduce radiation emission, consider the following recommendations:

- Position the LCD bus interface in inner layers of the PCB.
- Add a ferrite bead on the CLK line.
- Add a ferrite bead on the LCD power supply.
- Select a shielded LCD connector.

SAMA5D27 Wireless SOM1

Functional Description

Figure 4-36. EMI Improvement Layout Example

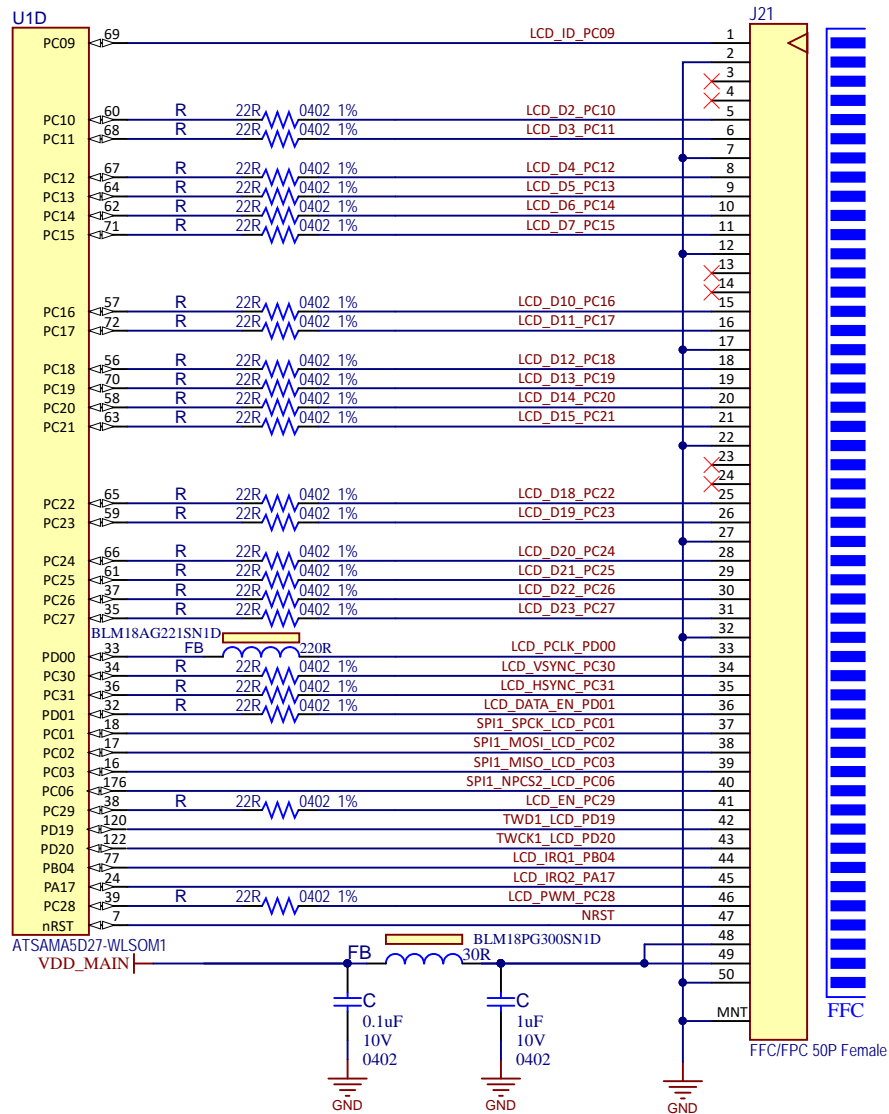

5. Electrical Characteristics

5.1 Absolute Maximum Ratings

Stresses beyond those listed under “Absolute Maximum Ratings” may cause permanent damage to the device. This is a stress rating only and functional operation of the device at these or other conditions beyond those indicated in the operational sections of this specification is not implied. Exposure to absolute maximum rating conditions for extended periods may affect device reliability.

Table 5-1. Absolute Maximum Ratings

Characteristic	Symbol	Min.	Max.	Unit
I/O Supply Voltage	VDDANA, VDDISC, VDDSDHC	-0.3	4.0	V
Fuse Supply Voltage	VDDFUSE	-0.3	3.0	V
Main Supply Voltage	VDD_MAIN	-0.3	6.0	V
Backup Supply Voltage	VDDBU	-0.3	4.0	V
Storage Temperature	T _{STORAGE}	-55	150	°C
RF Input Power Maximum	–	–	23	dBm
Maximum Input Current	VDD_MAIN	–	2	A

5.2 Recommended Operating Conditions

The following table provides the operating ratings for the ATSAMA5D27-WLSOM1 module.

Table 5-2. Recommended Operating Ratings

Characteristic	Symbol	Min.	Max.	Unit
I/O Supply Voltage	VDDANA, VDDISC, VDDSDHC	1.6	3.6	V
Fuse Supply Voltage	VDDFUSE	2.25	2.75	V
Main Supply Voltage	VDD_MAIN	3.0	5.5	V
Backup Supply Voltage	VDDBU	1.65	3.6	V
Operating Temperature	T _A	-40	85	°C

5.3 DC Characteristics

The following characteristics are applicable to the operating temperature range T_A = -40°C to +85°C, unless otherwise specified.

Table 5-3. DC Electrical Characteristics for GPIO Inputs

Pad	Parameters	Conditions	Min.	Typ.	Max.	Unit
V _{IL}	Low-level Input Voltage	All GPIO @ 3.3V	-0.3	–	0.4	V
V _{IH}	High-level Input Voltage	All GPIO @ 3.3V	2.3	–	3.6	V
V _{OL}	Low-level Output Voltage	I _O Max.	–	–	0.41	V
V _{OH}	High-level Output Voltage	I _O Max.	2.9	–	–	V

SAMA5D27 Wireless SOM1

Electrical Characteristics

.....continued

Pad	Parameters	Conditions	Min.	Typ.	Max.	Unit
I _{IL}	Low-level Input Current	All GPIO @ 3.3V	-1	-	1	μA
I _{IH}	High-level Input Current	All GPIO @ 3.3V	-1	-	1	μA
I _{OL}	Low-level Output Current	All GPIO @ 3.3V / Low	-2	-	-	mA
		All GPIO @ 3.3V / High	-32	-	-	mA
I _{OH}	High-level Output Current	All GPIO @ 3.3V / Low	-	-	2	mA
		All GPIO @ 3.3V / High	-	-	32	mA

5.4 Power Consumption

5.4.1 Hardware Setup

The following figure illustrates the hardware architecture and the position of ammeters for the measurements performed on ATSAM5D27-WLSOM1-EK1 board.

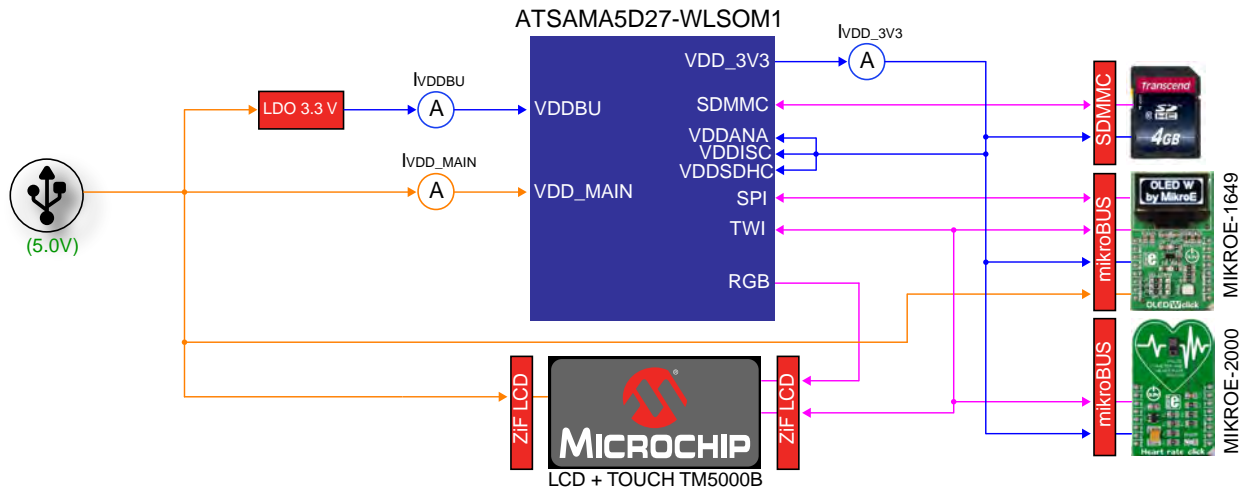

5.4.2 Software Setup and Command

5.4.2.1 Software Setup

The Linux image used for the tests is available on Linux4SAM.org.

The board web page is here: www.linux4sam.org/bin/view/Linux4SAM/Sama5d27WLSom1EKMainPage.

The image used is the Buildroot Based Demo with PDA5" configuration, available in the [Demo archives](#) section of the page.

5.4.2.2 Software Commands

To activate various interfaces, the following commands are used:

For Wi-Fi activity

```
modprobe wilc-sdio
wpa_supplicant -Dnl80211 -iwlan0 -c/etc/wpa_supplicant.conf &
wpa_cli -iwlan0 -p/var/run/wpa_supplicant add_network
wpa_cli -iwlan0 -p/var/run/wpa_supplicant set_network 2 ssid '"IPERF_TEST"'
```

SAMA5D27 Wireless SOM1

Electrical Characteristics

```
wpa_cli -iwlan0 -p/var/run/wpa_supplicant set_network 2 key_mgmt WPA-PSK
wpa_cli -iwlan0 -p/var/run/wpa_supplicant set_network 2 psk '"12345678"'
wpa_cli -iwlan0 -p/var/run/wpa_supplicant select_network 2
udhcpc -iwlan0 &
iperf -s -i 1 -w 512k & (At WLSOM terminal)
iperf -c 192.168.1.3 -i 1 -t 300 -w 512k (At PC terminal)
```

For Ethernet activity

```
ping 192.168.1.2 &
```

For SD Card Read/Write activity

```
sh sdcardtest.sh &
```

For USB Host Copy activity

```
sh copy.sh &
```

For OLED activity

```
sh oledtest.sh &
```

For Heart Beat activity

```
python hr_click_board.py &
```

For LCD activity

```
sh lcdtest.sh &
```

5.4.2.3 Current Consumption Measurements in Linux Environment

Scenario Setup		Scenario N°1	Scenario N°2	Scenario N°3	Scenario N°4	Scenario N°5	Scenario N°6
		Before Boot. Module Off Not Started	After Linux Boot	Wi-Fi Activity Channel 6	Wi-Fi + Ethernet Activities	Wi-Fi + SD Card+ LCD Activities	Wi-Fi + Ethernet + USB Host + SD Card + Heart Beat + OLED + LCD Activities
Current Consumption	IVDD_MAIN @5V	60.5 μ A	162 mA	207 mA	208 mA	244 mA	250 mA
	IVDDBU @ 3.3V	13.8 μ A	10.1 μ A	10.1 μ A	10.2v	10.1 μ A	10.1 μ A
	IVDD_3V3 @ 3.3V	0 mA	1.21 mA	1.31 mA	1.48 mA	7.94mA	7.95mA
Power Consumption	PVDD_MAIN @5V	302.5 μ W	810 mW	1035 mW	1040 mW	1220 mW	1250 mW
	PVDDBU @ 3.3V	45.54 μ W	33.33 μ W	33.33 μ W	33.66 μ W	33.33 μ W	33.33 μ W
	PVDD_3V3 @ 3.3V	0 mW	3.993 mW	4.323 mW	4.884 mW	26.202 mW	26.325 mW

5.4.2.4 Current Consumption in Backup Modes

Scenario Setup		Scenario N°7	Scenario N°8	Scenario N°9	Scenario N°10	Scenario N°11
		Backup Mode	Backup Mode w/ Self refresh	ULP0 Mode	ULP1 Mode	Idle Mode
Current Consumption	IVDD_MAIN @5V	58.9 μ A	82.6 mA	59.8 mA	58.4 mA	58.7 mA
	IVDDBU @ 3.3V	13.6 μ A	9.6 μ A	13.7 μ A	6.2 μ A	6.3 μ A
	IVDD_3V3 @ 3.3V	578.9 μ A	5.34 mA	870 μ A	780 μ A	800 μ A

SAMA5D27 Wireless SOM1

Electrical Characteristics

.....continued

		Scenario N°7	Scenario N°8	Scenario N°9	Scenario N°10	Scenario N°11
Scenario Setup		Backup Mode	Backup Mode w/ Self refresh	ULP0 Mode	ULP1 Mode	Idle Mode
Power Consumption	PVDD_MAIN @5V	294.5 μ W	413 mW	299 mW	292 mW	293.5 mW
	PVDDBU @ 3.3V	44.88 μ W	31.68 μ W	45.21 μ W	20.46 μ W	20.79 μ W
	PVDD_3V3 @ 3.3V	1910 μ W	17.62 μ W	2871 μ W	2574 μ W	2640 μ W

5.5 Radio Performance

For more details about radio performance, refer to the [ATWILC3000-MR110xA](#) data sheet.

6. Mechanical Characteristics

6.1 Module Outline Drawings

Figure 6-1. ATSAMA5D27-WLSOM1 Module Drawing

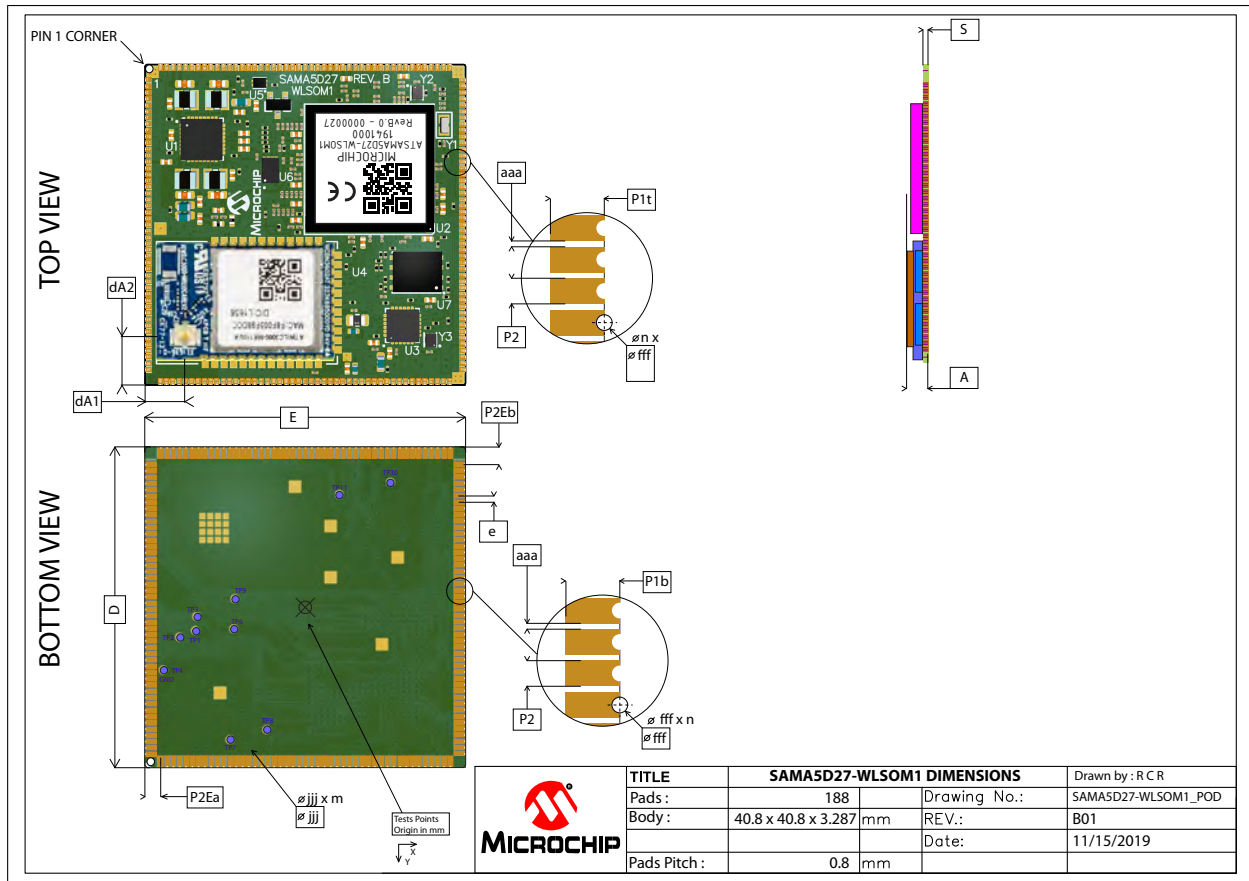

Table 6-1. ATSAMA5D27-WLSOM1 Module Dimensions (in mm)

	Symbol	Common Dimensions	Common Dimensions			Comments
			Min.	Typ.	Max.	
Body Size	X	E	40.700	40.800	40.900	
	Y	D	40.700	40.800	40.900	
Pad Pitch	e		–	0.800	–	
PCB Thickness	S		1.150	1.200	1.250	
Total Thickness	A		–	3.287	3.387	
Pad Length ⁽¹⁾	Top Side	P1t	–	0.800	–	
	Bottom Side	P1b	–	1.500	–	
Pad Width ⁽¹⁾		P2	–	0.600	–	Solder Mask Defined 0.550
Pad Space ⁽¹⁾		aaa	–	0.200	–	

SAMA5D27 Wireless SOM1

Mechanical Characteristics

.....continued

	Symbol	Common Dimensions			Comments	
		Min.	Typ.	Max.		
Opening Drill Diameter	fff	–	0.400	–		
Pad Count	n	–	188	–		
Test Point Diameter	jjj	–	1.000	–		
Test Point Count	m	–	10	–		
Pad Axis to Edge ⁽¹⁾	X	P2Ea	–	2.000	–	
	Y	P2Eb	–	2.000	–	
U.FL Antenna Axis to Edge	X	dA1	–	5.011	–	
	Y	dA2	–	6.161	–	

Notes:

- Tolerances are defined upon:
 - IPC A600 – Class2
 - IPC 2615
- Test points placed under module are for production purposes only. No connection on these points is allowed. They are listed to avoid any contact with the main board vias or copper areas.

Table 6-2. Test Point Position Compared to Center Origin

Test Point Number	X	Y	Voltage Point
TP1	-13.875	3.000	VDDUTMII
TP2	-15.900	3.825	VDD_3V3
TP3	-13.700	1.225	VDDOSC_PLL
TP4	-17.975	8.000	GND
TP6	-9.025	2.775	VDDIODDR
TP7	-9.500	16.825	VDDCORE
TP8	-4.850	15.550	VDDPLLA
TP9	-8.875	-1.025	VLDO1
TP10	10.825	-15.800	VDDA_3V3
TP11	4.350	-14.250	VBAT

6.2 Module Land Pattern (Host Board PCB Footprint)

Figure 6-2. ATSAMA5D27-WLSOM1 Land Pattern Drawing

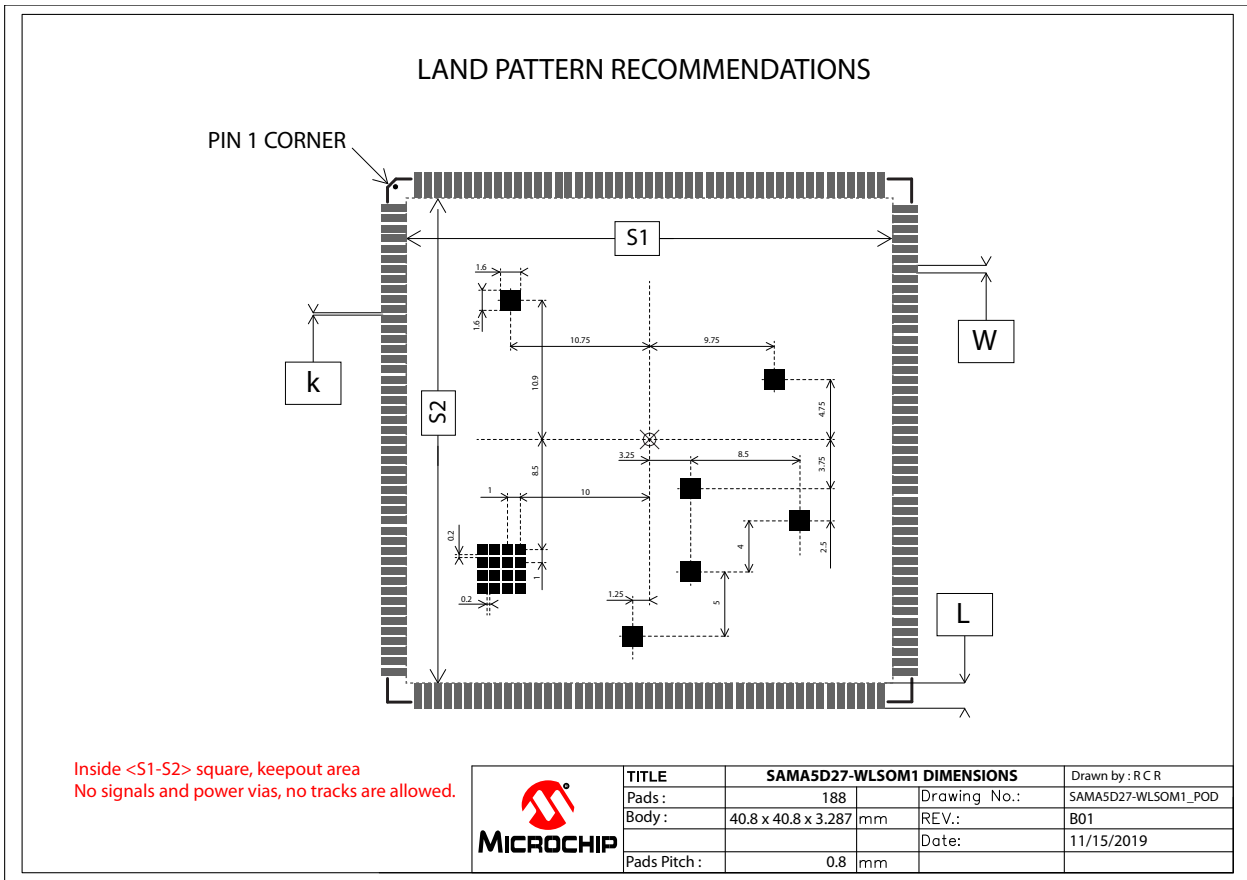
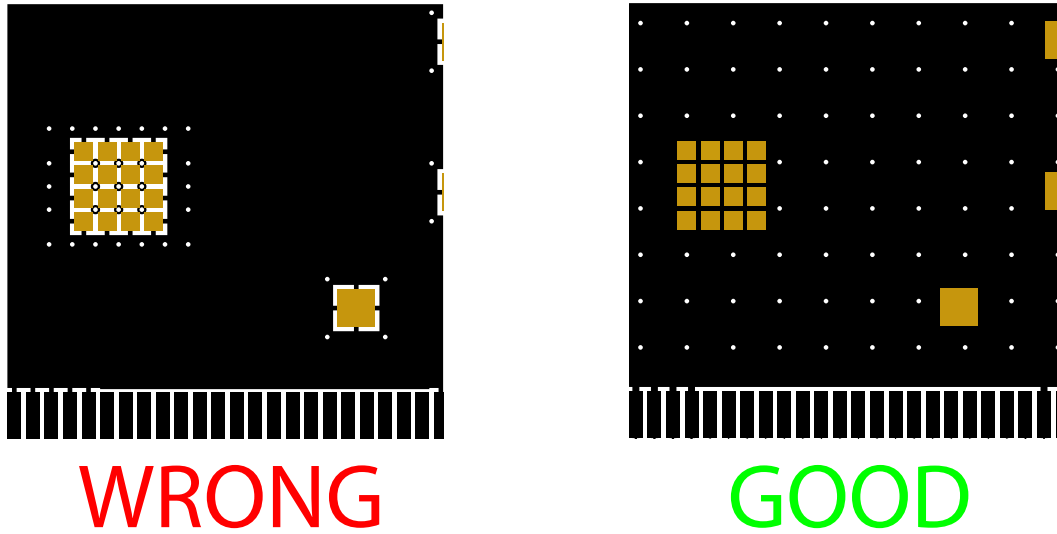

Table 6-3. ATSAMA5D27-WLSOM1 Land Pattern Dimensions (in mm)

Parameter	Symbol	Common Dimensions			Comments
		Min.	Typ.	Max.	
Land Pattern Pad Width	W	–	0.600	–	Solder Mask Defined 0.550
Land Pattern Pad Length	L	–	2.000	–	–
Land Pattern Pad X Space	S1	–	37.800	–	–
Land Pattern Pad Y Space	S2	–	37.800	–	–
Land Pattern Pad Space	k	–	0.200	–	–

Figure 6-3. GND Pads Overview and Layout Recommendation



Note: It is recommended to use the layout as shown on the right above. This solution increases RF performance of the Wi-Fi and Bluetooth communications and optimizes heat sink capability of the system; on the host board, do not apply thermal brakes on the TOP layout around GND pads.

Note: A full GND plane with evenly distributed GND vias should be placed underneath the module, on the top layer of the host board.

6.3 Other Characteristics

Table 6-4. ATSAMA5D27-WLSOM1 Other Characteristics

Parameter	Measurement		Comments
	Value	Unit	
Weight	7.91	g	

7. Assembly and Storage Information

7.1 Storage Condition

7.1.1 Moisture Barrier Bag Before Opening

A moisture barrier bag must be stored at a temperature of less than 30°C with humidity under 85% RH.

The calculated shelf life for the dry-packed product is 12 months from the date the bag is sealed.

7.1.2 Moisture Barrier Bag Open

Humidity indicator cards must be blue, RH < 30%.

7.2 Motherboard Solder Paste

The SnAgCu eutectic solder with melting temperature of 217°C is most commonly used for lead-free solder reflow application. This alloy is widely accepted in the semiconductor industry due to its low cost, relatively low melting temperature, and good thermal fatigue resistance. Some recommended pastes include NC-SMQ® 230 flux and Indalloy® 241 solder paste made up of 95.5 Sn/3.8 Ag/0.7 Cu or SENJU N705-GRN3360-K2-V Type 3, or SENJU M705-GRN360-K-V, no clean paste.

7.3 Motherboard Stencil Design

The recommended stencil is a laser-cut, stainless-steel type with thickness of 100 µm to 130 µm and an approximate ratio of 1:1 for stencil opening to pad dimension. To improve paste release, a positive taper with bottom opening 25 µm larger than the top is utilized. Local manufacturers may find other combinations of stencil thickness and aperture size to get good results.

7.4 Bake Information

The ATSAMA5D27-WLSOM1 module is rated MSL 3, indicating that storage and assembly processes must be compliant with IPC/JEDEC J-STD-033C.

The ATSAMA5D27-WLSOM1 module has a total thickness of 3.287 mm (PCB and SMD mounted) and is comparable to a die package. Thus baking instructions must comply with Table 4-1 of J-STD-033-C as a package body comprised between 2.0 mm and 4.5 mm.

Refer to the highlighted information in the table below.

SAMA5D27 Wireless SOM1

Assembly and Storage Information

Figure 7-1. IPC/JEDEC Table

Package Body	Level	Bake @ 125°C		Bake @ 90°C ≤5% RH		Bake @ 40°C ≤5% RH	
		Exceeding Floor Life by >72 h	Exceeding Floor Life by ≤72 h	Exceeding Floor Life by >72 h	Exceeding Floor Life by ≤72 h	Exceeding Floor Life by >72 h	Exceeding Floor Life by ≤72 h
Thickness ≤1.4 mm	2	5 hours	3 hours	17 hours	11 hours	8 days	5 days
	2a	7 hours	5 hours	23 hours	13 hours	9 days	7 days
	3	9 hours	7 hours	33 hours	23 hours	13 days	9 days
	4	11 hours	7 hours	37 hours	23 hours	15 days	9 days
	5	12 hours	7 hours	41 hours	24 hours	17 days	10 days
	5a	16 hours	10 hours	54 hours	24 hours	22 days	10 days
Thickness >1.4 mm ≤2.0 mm	2	18 hours	15 hours	63 hours	2 days	25days	20 days
	2a	21 hours	16 hours	3 days	2 days	29 days	22 days
	3	27 hours	17 hours	4 days	2 days	37 days	23 days
	4	34 hours	20 hours	5 days	3 days	47 days	28 days
	5	40 hours	25 hours	6 days	4 days	57 days	35 days
	5a	48 hours	40 hours	8 days	6 days	79 days	56 days
Thickness >2.0 mm ≤4.5 mm	2	48 hours	48 hours	10 days	7 days	79 days	67 days
	2a	48 hours	48 hours	10 days	7 days	79 days	67 days
	3	48 hours	48 hours	10 days	8 days	79 days	67 days
	4	48 hours	48 hours	10 days	10 days	79 days	67 days
	5	48 hours	48 hours	10 days	10 days	79 days	67 days
	5a	48 hours	48 hours	10 days	10 days	79 days	67 days
BGA package >17 mm x 17 mm or any stacked die package (See Note 2)	2-6	96 hours	As above per package thickness and moisture level	Not applicable	As above per package thickness and moisture level	Not applicable	As above per package thickness and moisture level

7.5 Reflow Profile

The ATSAMA5D27-WLSOM1 is assembled using standard lead-free reflow profile IPC/JEDEC J-STD-020E.

In addition to the initial assembly solder, we recommend a maximum of two additional soldering processes:

- the assembly on main board
- a spare heating pass in case the module must be removed from the main board for analysis

The ATSAMA5D27-WLSOM1 can be soldered to the host PCB by using the standard and lead-free solder reflow profile. To avoid damage to the module, follow the JEDEC recommendations as well as those listed below:

- Do not exceed the peak temperature (Tp) of 245°C.
- Refer to the solder paste data sheet for specific reflow profile recommendations.
- Use no-clean flux solder paste.
- Use only one flow. If the PCB requires multiple flows, mount the module at the time of the final flow.

SAMA5D27 Wireless SOM1

Assembly and Storage Information

Figure 7-2. Reflow Profile Example used for Soldering ATSAMA5D27-WLSOM1 Module on ATSAMA5D27-WLSOM1-EK1 Board

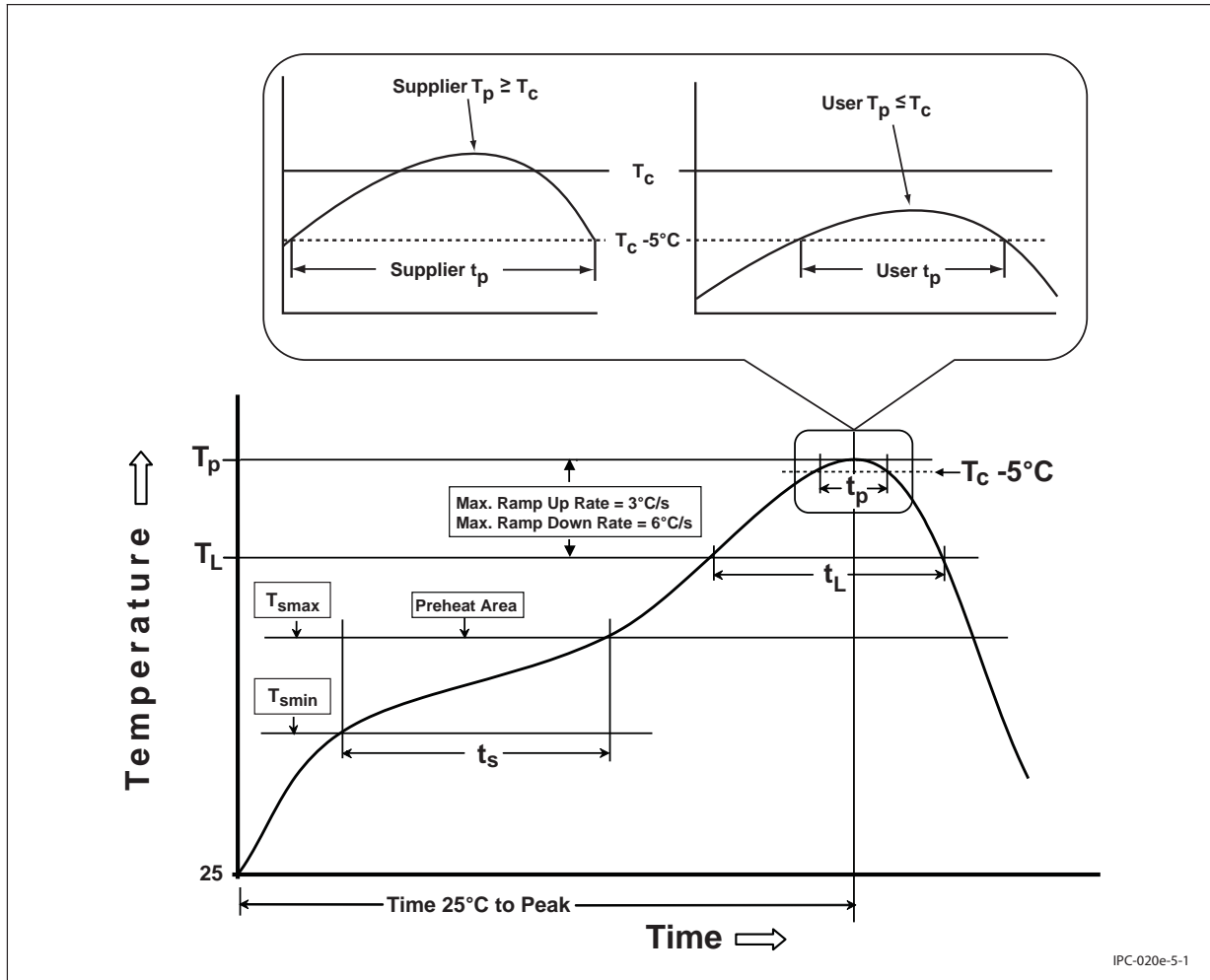

Table 7-1. Reflow Profile Table Parameters

Profile Feature		J-STD-020E Profile
Pre-heat Temperature Min	T_{smin}	150°C
Pre-heat Temperature Max	T_{smax}	200°C
Temperature Rise	t_s (from T_{smin} to T_{smax})	60 to 120 seconds
Ramp-up Rate	T_L to T_P	3°C/sec. max.
Liquidous Temperature Time maintained above 217°C	t_L	60 to 150 seconds
Peak Temperature	T_P	245°C
Time (t_p) within 5°C of the specified classification temperature (T_C)	t_p	30 seconds
Ramp-down rate	T_P to T_L	6°C/sec. max.
Time 25°C to peak temperature	–	8 minutes max.

8. Regulatory Approval

The ATSAMA5D27-WLSOM1 is the implementation of the ATWILC3000-MR110UA module in a particular host, in this case the PCB of the ATSAMA5D27-WLSOM1.

The ATWILC3000-MR110UA module has received regulatory approval for the following countries:

- United States/FCC ID: 2ADHKWILC3000U
- Canada/ISED:
 - IC: 20266-WILC3000UA
 - HVIN: ATWILC3000-MR110UA
 - PMN: ATWILC3000-MR110UA
- Europe/CE

8.1 United States

ATWILC3000-MR110UA module has received Federal Communications Commission (FCC) CFR47 Telecommunications, Part 15 Subpart C “Intentional Radiators” single-modular approval in accordance with Part 15.212 Modular Transmitter approval. Single-modular transmitter approval is defined as a complete RF transmission sub-assembly, designed to be incorporated into another device, that must demonstrate compliance with FCC rules and policies independent of any host. A transmitter with a modular grant can be installed in different end-use products (referred to as a host, host product, or host device) by the grantee or other equipment manufacturer, then the host product may not require additional testing or equipment authorization for the transmitter function provided by that specific module or limited module device.

The user must comply with all of the instructions provided by the Grantee, which indicate installation and/or operating conditions necessary for compliance.

A host product itself is required to comply with all other applicable FCC equipment authorization regulations, requirements, and equipment functions that are not associated with the transmitter module portion. For example, compliance must be demonstrated: to regulations for other transmitter components within a host product; to requirements for unintentional radiators (Part 15 Subpart B), such as digital devices, computer peripherals, radio receivers, etc.; and to additional authorization requirements for the non-transmitter functions on the transmitter module (i.e., Suppliers Declaration of Conformity (SDoC) or certification) as appropriate (e.g., Bluetooth and Wi-Fi transmitter modules may also contain digital logic functions).

8.1.1 Labeling and User Information Requirements

The ATWILC3000-MR110UA module has been labeled with its own FCC ID number, and if the FCC ID is not visible when the module is installed inside another device, then the outside of the finished product into which the module is installed must display a label referring to the enclosed module. This exterior label should use the following wording:

Contains Transmitter Module FCC ID: 2ADHKWILC3000U

or

Contains FCC ID: 2ADHKWILC3000U

This device complies with Part 15 of the FCC Rules. Operation is subject to the following two conditions: (1) this device may not cause harmful interference, and (2) this device must accept any interference received, including interference that may cause undesired operation.

This equipment has been tested and found to comply with the limits for a Class B digital device, pursuant to part 15 of the FCC Rules. These limits are designed to provide reasonable protection against harmful interference in a residential installation. This equipment generates, uses and can radiate radio frequency energy, and if not installed and used in accordance with the instructions, may cause harmful interference to radio communications. However, there is no guarantee that interference will not occur in a particular installation. If this equipment does cause harmful interference to radio or television reception, which can be determined by turning the equipment off and on, the user is encouraged to try to correct the interference by one or more of the following measures:

- Reorient or relocate the receiving antenna
- Increase the separation between the equipment and receiver
- Connect the equipment into an outlet on a circuit different from that to which the receiver is connected
- Consult the dealer or an experienced radio/TV technician for help

Additional information on labeling and user information requirements for Part 15 devices can be found in KDB Publication 784748, which is available at the FCC Office of Engineering and Technology (OET) Laboratory Division Knowledge Database (KDB) <https://apps.fcc.gov/oetcf/kdb/index.cfm>

8.1.2 RF Exposure

All transmitters regulated by FCC must comply with RF exposure requirements. KDB 447498 General RF Exposure Guidance provides guidance in determining whether proposed or existing transmitting facilities, operations or devices comply with limits for human exposure to Radio Frequency (RF) fields adopted by the Federal Communications Commission (FCC).

From the FCC Grant: Output power listed is conducted. This transmitter is restricted for use with the specific antenna(s) tested in this application for Certification.

The antenna(s) used with this transmitter must be installed to provide a separation distance of at least 8.0 cm from all persons and must not be co-located or operating in conjunction with any other antenna or transmitter. Users and installers must be provided with antenna installation instructions and transmitter operating conditions for satisfying RF exposure compliance.

8.1.3 Approved External Antennas

To maintain modular approval in the United States, only the antenna types that have been tested shall be used. It is permissible to use different antenna, provided they are of the same antenna type, antenna gain (equal to or less than), similar in band and out-of band characteristics (consult specification sheet for cutoff frequencies).

Testing of the ATWILC3000-MR110UA module was performed with the antenna types listed in the table [List of External Antennas](#).

8.1.4 Module Integration in the Host Product

Host products are to ensure continued compliance as per [KDB 996369 Module Integration Guide](#).

8.2 Canada

The ATSAMA5D27-WLSOM1 module contains the ATWILC3000-MR110UA which has been certified for use in Canada under Innovation, Science, and Economic Development (ISED, formerly Industry Canada) Radio Standards Procedure (RSP) RSP-100, Radio Standards Specification (RSS) RSS-Gen and RSS-247. Modular approval permits the installation of a module in a host device without the need to recertify the device.

8.2.1 Labeling and User Information Requirements

Labeling Requirements (from RSP-100 - Issue 11, Section 3): The host product shall be properly labeled to identify the module within the host device.

The Innovation, Science and Economic Development Canada certification label of a module shall be clearly visible at all times when installed in the host device; otherwise, the host product must be labeled to display the Innovation, Science and Economic Development Canada certification number of the module, preceded by the word "Contains" or similar wording expressing the same meaning, as follows:

Contains IC: 20266-WILC3000UA

SAMA5D27 Wireless SOM1

Regulatory Approval

User Manual Notice for License-Exempt Radio Apparatus (from Section 8.4 RSS-Gen, Issue 5, April 2018): User manuals for license-exempt radio apparatus shall contain the following or equivalent notice in a conspicuous location in the user manual or alternatively on the device or both:

This device contains license-exempt transmitter(s)/receiver(s) that comply with Innovation, Science and Economic Development Canada's license-exempt RSS(s). Operation is subject to the following two conditions:

1. This device may not cause interference;
2. This device must accept any interference, including interference that may cause undesired operation of the device.

L'émetteur/récepteur exempt de licence contenu dans le présent appareil est conforme aux CNR d'Innovation, Sciences et Développement économique Canada applicables aux appareils radio exempts de licence. L'exploitation est autorisée aux deux conditions suivantes:

1. L'appareil ne doit pas produire de brouillage;
2. L'appareil doit accepter tout brouillage radioélectrique subi, même si le brouillage est susceptible d'en compromettre le fonctionnement.

Transmitter Antenna (From Section 6.8 RSS-GEN, Issue 5, April 2018): User manuals, for transmitters shall display the following notice in a conspicuous location:

This radio transmitter [IC: 20266-WILC3000UA] has been approved by Innovation, Science and Economic Development Canada to operate with the antenna types listed below, with the maximum permissible gain indicated. Antenna types not included in this list that have a gain greater than the maximum gain indicated for any type listed are strictly prohibited for use with this device.

Le présent émetteur radio [IC: 20266-WILC3000UA] a été approuvé par Innovation, Sciences et Développement économique Canada pour fonctionner avec les types d'antenne énumérés cidessous et ayant un gain admissible maximal. Les types d'antenne non inclus dans cette liste, et dont le gain est supérieur au gain maximal indiqué pour tout type figurant sur la liste, sont strictement interdits pour l'exploitation de l'émetteur.

Immediately following the above notice, the manufacturer shall provide a list of all antenna types which can be used with the transmitter, indicating the maximum permissible antenna gain (in dBi) and the required impedance for each antenna type.

Testing of the ATWILC3000-MR110UA module was performed with the antenna types listed in the table [List of External Antennas](#).

8.2.2 RF Exposure

All transmitters regulated by Innovation, Science and Economic Development Canada (ISED) must comply with RF exposure requirements listed in RSS-102 - Radio Frequency (RF) Exposure Compliance of Radio communication Apparatus (All Frequency Bands).

This transmitter is restricted for use with a specific antenna tested in this application for certification, and must not be co-located or operating in conjunction with any other antenna or transmitters within a host device, except in accordance with Canada multi-transmitter product procedures.

The installation of the transmitter must ensure compliance is demonstrated according to the ISED SAR procedures.

8.2.3 Helpful Web Sites

Innovation, Science and Economic Development Canada (ISED): <http://www.ic.gc.ca/>.

8.3 Europe

The ATSAMA5D27-WLSOM1 module is a Radio Equipment Directive (RED) assessed radio module that is CE marked and has been manufactured and tested with the intention of being integrated into a final product.

SAMA5D27 Wireless SOM1

Regulatory Approval

The ATSAMA5D27-WLSOM1 module has been tested to RED 2014/53/EU Essential Requirements for Health and Safety (Article 3.1(a)), Electromagnetic Compatibility (EMC) (Article 3.1(b)), and Radio (Article 3.2) and are summarized in [European Compliance Testing](#).

The ETSI provides guidance on modular devices in “Guide to the application of harmonized standards covering articles 3.1b and 3.2 of the Directive 2014/53/EU (RED) to multi-radio and combined radio and non-radio equipment” document available for download from the following location: http://www.etsi.org/deliver/etsi_eg/203300_203399/203367/01.01.01_60/eg_203367v010101p.pdf

To maintain conformance to the testing listed in [European Compliance Testing](#), the module shall be installed in accordance with the installation instructions in this data sheet and shall not be modified.

When integrating a radio module into a completed product the integrator becomes the manufacturer of the final product and is therefore responsible for demonstrating compliance of the final product with the essential requirements against the RED.

8.3.1 Labeling and User Information Requirements

The label on the final product which contains the ATSAMA5D27-WLSOM1 module must follow CE marking requirements.

8.3.2 Conformity Assessment

From ETSI Guidance Note EG 203367, section 6.1 Non-radio products are combined with a radio product:

If the manufacturer of the combined equipment installs the radio product in a host non-radio product in equivalent assessment conditions (i.e. host equivalent to the one used for the assessment of the radio product) and according to the installation instructions for the radio product, then no additional assessment of the combined equipment against article 3.2 of the RED is required.

The European Compliance Testing listed in the table below was performed using the antennas listed in the table [List of External Antennas](#).

Table 8-1. European Compliance Testing

Certification	Standards	Article	Laboratory	Report Number	Date	
Safety	EN 62368-1:2014, EN 62368-1:2014/A11:2017			50307896 001	22 Oct 2019	
Health	EN 300 328 V2.1.1/ EN 62311:2008	3.1(a)	TÜV Rheinland, Taiwan	CN21Y8H8(EN300328-2.4GHz) 001 ⁽¹⁾	16 Apr 2021	
	EN 300 328 V2.1.1/ EN 62479:2010			CN21Y8H8(EN300328-2.4GHz) 002 ⁽¹⁾		
				CN21JCAP(EN300328-BLE) 001 ⁽¹⁾	16 Apr 2021	
				CN21F4UB(EN300328-BLE) 001 ⁽¹⁾		
EMC	EN 301 489-1 V2.1.1 EN 301 489-1 V2.2.3*	3.1(b)	TÜV Rheinland, Taiwan	50126738 001 ⁽¹⁾	06 Jun 2018	
	EN 301 489-17 V3.1.1 EN 301 489-17 V3.2.0					
	EN 55032:2012+AC:2013/ EN 55032:2015+AC:2016/ EN55024:2010+A1:2015				50304514 001	22 oct 2019
Radio	EN 300 328 V2.2.2	3.2		CN202UIO (EN300328-BLE) 001 ⁽¹⁾	13 Nov 2020	
				CN202UIO (EN300328-BT) 001 ⁽¹⁾		
				CN202UIO (EN300328-WiFi) 001 ⁽¹⁾		

Note:

1. Reports correspond to ATWILC3000-MR110UA.

8.3.3 Simplified EU Declaration of Conformity

Hereby, Microchip Technology Inc. declares that the radio equipment type [ATSAMA5D27-WLSOM1] is in compliance with Directive 2014/53/EU.

The full text of the EU declaration of conformity is available at the following internet address : <https://www.microchip.com/wwwproducts/en/ATSAMA5D27-WLSOM1>

8.3.4 Helpful Web Sites

A document that can be used as a starting point in understanding the use of Short Range Devices (SRD) in Europe is the European Radio Communications Committee (ERC) Recommendation 70-03 E, which can be downloaded from the European Communications Committee (ECC) at: <http://www.ecodocdb.dk/>

Additional helpful web sites are:

- Radio Equipment Directive (2014/53/EU):
 - https://ec.europa.eu/growth/single-market/european-standards/harmonised-standards/rtte_de
- European Conference of Postal and Telecommunications Administrations (CEPT):
 - <http://www.cept.org>
- European Telecommunications Standards Institute (ETSI):
 - <http://www.etsi.org>
- European Communications Committee (ECC):
 - <http://www.ecodocdb.dk>
- The Radio Equipment Directive Compliance Association (REDCA):
 - <http://www.redca.eu/>

8.4 Approved Antenna Types

ATWILC3000-MR110UA was tested and approved for use with the antennas listed in the table below.

Different antenna may be used, provided they are of the identical antenna type and antenna gain (equal to or less than) and have similar in-band and out-of-band characteristics (consult specification sheet for cutoff frequencies).

If other antenna types are used, the OEM installer must authorize the antenna with respective regulatory agencies and ensure its compliance.

Table 8-2. List of External Antennas⁽¹⁾

P/N	Vendor	Antenna Gain @ 2.4 GHz Band	Antenna Type	ATWILC3000-MR110UA		Cable Length/ Remarks
				FCC ⁽²⁾ (3)	ISED CE	
W3525B039	Pulse Electronics Corporation	2 dBi	PCB	X	X	100 mm
RFDPA870920IMLB301	WALSIN	1.84 dBi	Dipole	X	X	200 mm
RFA-02-P33	Aristotle	2 dBi	PCB	X	X	150 mm
RN-SMA-S	Microchip	0.56 dBi	Dipole	X	X	SMA to u.FL cable length of 100 mm ⁽²⁾ ⁽³⁾
RFA-02-D3	Aristotle	2 dBi	Dipole	X	X	150 mm
RFA-02-G03	Aristotle	2 dBi	Metal Stamp	X	X	150 mm
RFA-02-L2H1	Aristotle	2 dBi	Dipole	X	X	150 mm
RFA-02-P05	Aristotle	2 dBi	PCB	X	X	150 mm
RFA-02-C2M2	Aristotle	2 dBi	Dipole	X	X	SMA to u.FL cable length of 100 mm ⁽²⁾ ⁽³⁾
86254	Delock	2 dBi	PCB	–	X	50 mm

Notes:

1. X = Covered under the certification.
2. If the end product using the module is designed to have an antenna port that is accessible to the end user, then a unique (nonstandard) antenna connector (refer to FCC [KDB 353028](#)) must be used; for example, Reverse Polarity - SMA.
3. If an RF coaxial cable is used between the module RF output and the enclosure, then a unique (nonstandard) antenna connector must be used in the enclosure wall for interface with antenna.

8.4.1 Antenna Placement Recommendations

Particular attention must be given to the placement of the antenna and its cable. The following recommendations must be applied:

- Ensure that the antenna cable is not expected to be routed over circuits generating electrical noise on the Host board.
- Antenna should not be placed in direct contact or in close proximity of the plastic casing/objects.
- Do not enclose the antenna within a metal shield.
- Keep any components which may radiate noise, signals or harmonics within the 2.4 GHz to 2.5 GHz frequency band away from the antenna and, if possible, shield those components. Any noise radiated from the host board in this frequency band degrades the sensitivity of the module.
- It is highly recommended not to run the antenna cable alongside or underneath the module. It is preferred that the cable is routed straight out of the module.
- The antenna should preferably be placed at a distance greater than 5 cm away from the module. The figure below indicates the area where the antenna should not be placed.

This recommendation is based on an open air measurement and does not take into account by any metal shielding of the customer end product. When a metal enclosure is used, the antenna can be located closer to the ATSAMA5D27-WLSOM1 module.

The drawing below indicates how the antenna cable should be routed depending on the location of the antenna with respect to the ATSAMA5D27-WLSOM1 PCB. Two possible options for the optimum routing of the cable are described.

These guidelines are generic only; customers need to check and fine tune the antenna positioning in the final host product.

SAMA5D27 Wireless SOM1

Regulatory Approval

Figure 8-1. SAMA5D27-WLSOM1 Antenna Placement

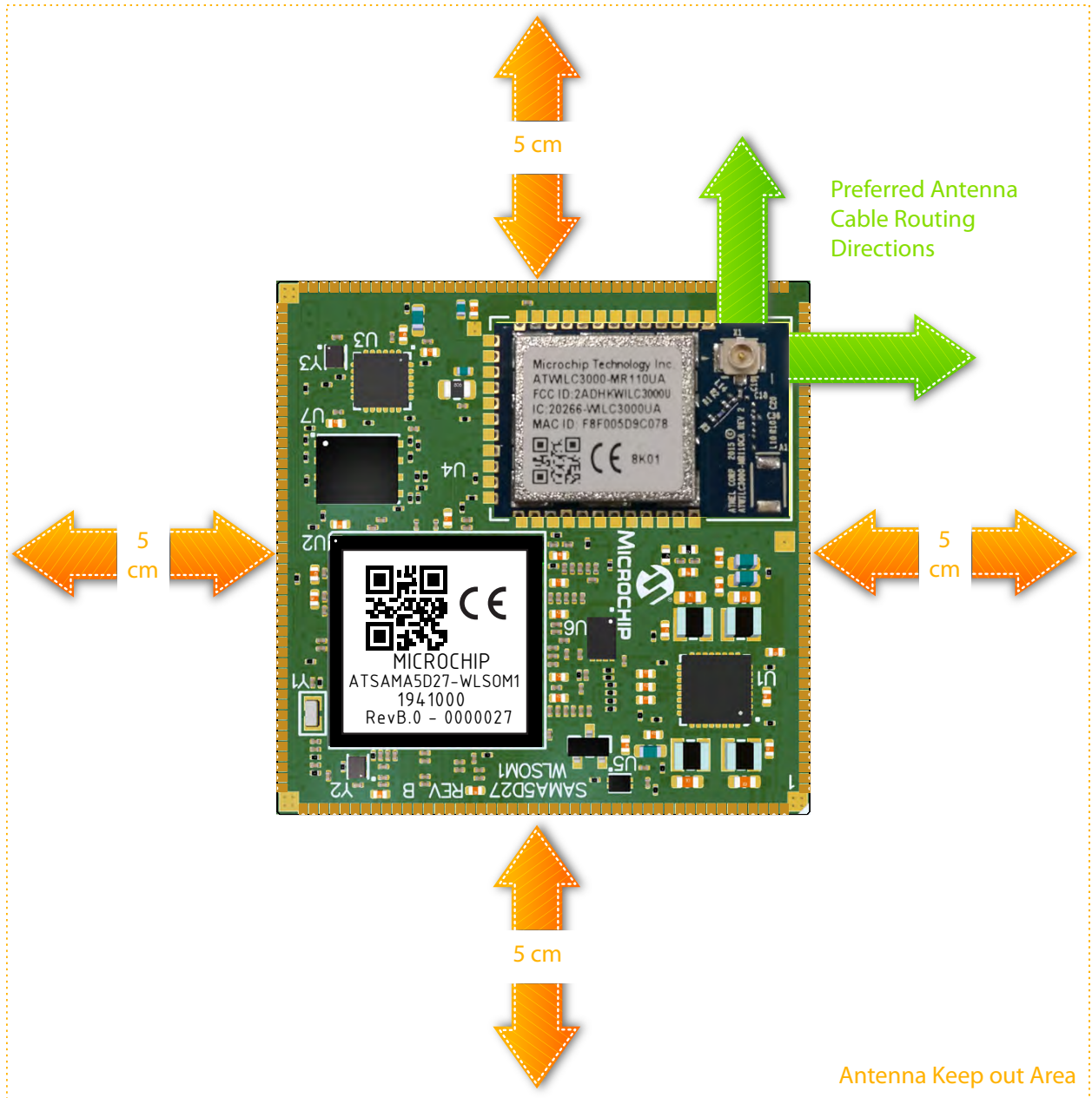

SAMA5D27 Wireless SOM1

Ordering Information

9. Ordering Information

Table 9-1. Ordering Details

Ordering Code	Package	Description	Regulatory Information
ATSAMA5D27-WLSOM1	40.8 x 40.8 x 3.287 mm	Certified Microchip MPU Wireless module with SAMA5D27, WILC3000 and U.FL connector	FCC, ISED, CE

10. Revision History

10.1 Rev. D - 08/2021

Updated [European Compliance Testing](#).

10.2 Rev. C - 03/2021

Note: Microchip is in the process of implementing inclusive language in our documentation. During this update, you may see the old terms and the new terms in our documentation text. We apologize for any confusion.

Throughout: Updated all secure element references to ATECC608B (was ATECC608A).

Updated [3.2 Pin List](#) and PIOA, PIOB, PIOC and PIOD pin description tables.

Updated [4.1.4 Secure Element](#).

Updated figure in [4.2.1 Power Architecture](#).

Updated figure in [4.2.2.2 Power Configurations: Multiple Supplies](#).

Updated figure in [4.2.4 Baseboard Power Delivery Application Diagram Example](#).

PIO muxing tables moved from [4.6 External Interfaces](#) to [3.2 Pin List](#).

Updated schematic and EMI example in [4.6.9 Interfacing with an LCD](#).

Added [5.4 Power Consumption](#).

Updated link to ATWILC3000 data sheet in [5.5 Radio Performance](#).

10.3 Rev. B - 12/2019

Updated [Figure 3-1](#).
Updated pins 151, 152 in Pin Description: System.
Updated figure in [4.1.4 Secure Element](#).
Updated figure in [4.2.1 Power Architecture](#).
Updated [4.3.1 Ethernet Phy](#).
Modified component reference in [4.5 Radio Subsystem](#).
Updated [4.6.1 Interfacing with an SD Card](#).
Updated [4.6.2 Interfacing with e-MMC](#).
Updated [4.6.3 Interfacing with NAND Flash](#).
Updated [4.6.4 Interfacing with an Image Sensor Controller \(ISC\)](#).
Updated [4.6.7 Interfacing with CLASS-D Audio Output](#).
Added [4.6.8 QTouch® Peripheral Touch Controller \(PTC\)](#).
Added [4.6.9 Interfacing with an LCD](#).
Section 4.7 content moved to [8. Regulatory Approval](#).
Updated [5.5 Radio Performance](#).
Updated [Figure 6-1](#).
Updated [Figure 6-2](#).
Added new section [8. Regulatory Approval](#).
Updated Regulatory Information in [9. Ordering Information](#).

10.4 Rev. A - 10/2019

First issue.

The Microchip Website

Microchip provides online support via our website at www.microchip.com/. This website is used to make files and information easily available to customers. Some of the content available includes:

- **Product Support** – Data sheets and errata, application notes and sample programs, design resources, user's guides and hardware support documents, latest software releases and archived software
- **General Technical Support** – Frequently Asked Questions (FAQs), technical support requests, online discussion groups, Microchip design partner program member listing
- **Business of Microchip** – Product selector and ordering guides, latest Microchip press releases, listing of seminars and events, listings of Microchip sales offices, distributors and factory representatives

Product Change Notification Service

Microchip's product change notification service helps keep customers current on Microchip products. Subscribers will receive email notification whenever there are changes, updates, revisions or errata related to a specified product family or development tool of interest.

To register, go to www.microchip.com/pcn and follow the registration instructions.

Customer Support

Users of Microchip products can receive assistance through several channels:

- Distributor or Representative
- Local Sales Office
- Embedded Solutions Engineer (ESE)
- Technical Support

Customers should contact their distributor, representative or ESE for support. Local sales offices are also available to help customers. A listing of sales offices and locations is included in this document.

Technical support is available through the website at: www.microchip.com/support

Product Identification System

To order or obtain information, e.g., on pricing or delivery, refer to the factory or the listed sales office.

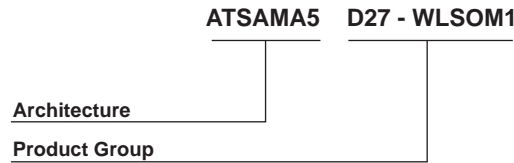

Architecture:	ATSAMA5	= Arm Cortex-A5 CPU
Product Group:	D27-WLSOM1	Certified MPU Wireless module with SAMA5D27, WILC3000 and U.FL connector

Examples:

- ATSAMA5D27-WLSOM1 = System-On-Module (SOM) based on the SAMA5D27, with 2 Gb LPDDR2-SDRAM running up to 500 MHz, and a Wi-Fi/BT Wireless module

Microchip Devices Code Protection Feature

Note the following details of the code protection feature on Microchip devices:

- Microchip products meet the specifications contained in their particular Microchip Data Sheet.
- Microchip believes that its family of products is secure when used in the intended manner and under normal conditions.
- There are dishonest and possibly illegal methods being used in attempts to breach the code protection features of the Microchip devices. We believe that these methods require using the Microchip products in a manner outside the operating specifications contained in Microchip's Data Sheets. Attempts to breach these code protection features, most likely, cannot be accomplished without violating Microchip's intellectual property rights.
- Microchip is willing to work with any customer who is concerned about the integrity of its code.
- Neither Microchip nor any other semiconductor manufacturer can guarantee the security of its code. Code protection does not mean that we are guaranteeing the product is "unbreakable." Code protection is constantly evolving. We at Microchip are committed to continuously improving the code protection features of our products. Attempts to break Microchip's code protection feature may be a violation of the Digital Millennium Copyright Act. If such acts allow unauthorized access to your software or other copyrighted work, you may have a right to sue for relief under that Act.

Legal Notice

Information contained in this publication is provided for the sole purpose of designing with and using Microchip products. Information regarding device applications and the like is provided only for your convenience and may be superseded by updates. It is your responsibility to ensure that your application meets with your specifications.

THIS INFORMATION IS PROVIDED BY MICROCHIP "AS IS". MICROCHIP MAKES NO REPRESENTATIONS OR WARRANTIES OF ANY KIND WHETHER EXPRESS OR IMPLIED, WRITTEN OR ORAL, STATUTORY OR OTHERWISE, RELATED TO THE INFORMATION INCLUDING BUT NOT LIMITED TO ANY IMPLIED WARRANTIES OF NON-INFRINGEMENT, MERCHANTABILITY, AND FITNESS FOR A PARTICULAR PURPOSE OR WARRANTIES RELATED TO ITS CONDITION, QUALITY, OR PERFORMANCE.

IN NO EVENT WILL MICROCHIP BE LIABLE FOR ANY INDIRECT, SPECIAL, PUNITIVE, INCIDENTAL OR CONSEQUENTIAL LOSS, DAMAGE, COST OR EXPENSE OF ANY KIND WHATSOEVER RELATED TO THE INFORMATION OR ITS USE, HOWEVER CAUSED, EVEN IF MICROCHIP HAS BEEN ADVISED OF THE POSSIBILITY OR THE DAMAGES ARE FORESEEABLE. TO THE FULLEST EXTENT ALLOWED BY LAW, MICROCHIP'S TOTAL LIABILITY ON ALL CLAIMS IN ANY WAY RELATED TO THE INFORMATION OR ITS USE

WILL NOT EXCEED THE AMOUNT OF FEES, IF ANY, THAT YOU HAVE PAID DIRECTLY TO MICROCHIP FOR THE INFORMATION. Use of Microchip devices in life support and/or safety applications is entirely at the buyer's risk, and the buyer agrees to defend, indemnify and hold harmless Microchip from any and all damages, claims, suits, or expenses resulting from such use. No licenses are conveyed, implicitly or otherwise, under any Microchip intellectual property rights unless otherwise stated.

Trademarks

The Microchip name and logo, the Microchip logo, Adaptec, AnyRate, AVR, AVR logo, AVR Freaks, BesTime, BitCloud, chipKIT, chipKIT logo, CryptoMemory, CryptoRF, dsPIC, FlashFlex, flexPWR, HELDO, IGLOO, JukeBlox, KeeLoq, Klear, LANCheck, LinkMD, maXStylus, maXTouch, MediaLB, megaAVR, Microsemi, Microsemi logo, MOST, MOST logo, MPLAB, OptoLyzer, PackeTime, PIC, picoPower, PICSTART, PIC32 logo, PolarFire, Prochip Designer, QTouch, SAM-BA, SenGenuity, SpyNIC, SST, SST Logo, SuperFlash, Symmetricom, SyncServer, Tachyon, TimeSource, tinyAVR, UNI/O, Vectron, and XMEGA are registered trademarks of Microchip Technology Incorporated in the U.S.A. and other countries.

AgileSwitch, APT, ClockWorks, The Embedded Control Solutions Company, EtherSynch, FlashTec, Hyper Speed Control, HyperLight Load, IntelliMOS, Libero, motorBench, mTouch, Powermite 3, Precision Edge, ProASIC, ProASIC Plus, ProASIC Plus logo, Quiet-Wire, SmartFusion, SyncWorld, Temux, TimeCesium, TimeHub, TimePictra, TimeProvider, WinPath, and ZL are registered trademarks of Microchip Technology Incorporated in the U.S.A.

Adjacent Key Suppression, AKS, Analog-for-the-Digital Age, Any Capacitor, AnyIn, AnyOut, Augmented Switching, BlueSky, BodyCom, CodeGuard, CryptoAuthentication, CryptoAutomotive, CryptoCompanion, CryptoController, dsPICDEM, dsPICDEM.net, Dynamic Average Matching, DAM, ECAN, Espresso T1S, EtherGREEN, IdealBridge, In-Circuit Serial Programming, ICSP, INICnet, Intelligent Paralleling, Inter-Chip Connectivity, JitterBlocker, maxCrypto, maxView, memBrain, Mindi, MiWi, MPASM, MPF, MPLAB Certified logo, MPLIB, MPLINK, MultiTRAK, NetDetach, Omniscient Code Generation, PICDEM, PICDEM.net, PICkit, PICtail, PowerSmart, PureSilicon, QMatrix, REAL ICE, Ripple Blocker, RTAX, RTG4, SAM-ICE, Serial Quad I/O, simpleMAP, SimpliPHY, SmartBuffer, SMART-I.S., storClad, SQI, SuperSwitcher, SuperSwitcher II, Switchtec, SynchroPHY, Total Endurance, TSHARC, USBCheck, VariSense, VectorBlox, VeriPHY, ViewSpan, WiperLock, XpressConnect, and ZENA are trademarks of Microchip Technology Incorporated in the U.S.A. and other countries.

SQTP is a service mark of Microchip Technology Incorporated in the U.S.A.

The Adaptec logo, Frequency on Demand, Silicon Storage Technology, and Symmcom are registered trademarks of Microchip Technology Inc. in other countries.

GestIC is a registered trademark of Microchip Technology Germany II GmbH & Co. KG, a subsidiary of Microchip Technology Inc., in other countries.

All other trademarks mentioned herein are property of their respective companies.

© 2021, Microchip Technology Incorporated, Printed in the U.S.A., All Rights Reserved.

ISBN: 978-1-5224-8706-7

AMBA, Arm, Arm7, Arm7TDMI, Arm9, Arm11, Artisan, big.LITTLE, Cordio, CoreLink, CoreSight, Cortex, DesignStart, DynamIQ, Jazelle, Keil, Mali, Mbed, Mbed Enabled, NEON, POP, RealView, SecurCore, Socrates, Thumb, TrustZone, ULINK, ULINK2, ULINK-ME, ULINK-PLUS, ULINKpro, μ Vision, Versatile are trademarks or registered trademarks of Arm Limited (or its subsidiaries) in the US and/or elsewhere.

Quality Management System

For information regarding Microchip's Quality Management Systems, please visit www.microchip.com/quality.

Worldwide Sales and Service

AMERICAS	ASIA/PACIFIC	ASIA/PACIFIC	EUROPE
<p>Corporate Office 2355 West Chandler Blvd. Chandler, AZ 85224-6199 Tel: 480-792-7200 Tel: 480-792-7277 Technical Support: www.microchip.com/support Web Address: www.microchip.com</p> <p>Atlanta Duluth, GA Tel: 678-957-9614 Fax: 678-957-1455</p> <p>Austin, TX Tel: 512-257-3370</p> <p>Boston Westborough, MA Tel: 774-760-0087 Fax: 774-760-0088</p> <p>Chicago Itasca, IL Tel: 630-285-0071 Fax: 630-285-0075</p> <p>Dallas Addison, TX Tel: 972-818-7423 Fax: 972-818-2924</p> <p>Detroit Novi, MI Tel: 248-848-4000</p> <p>Houston, TX Tel: 281-894-5983</p> <p>Indianapolis Noblesville, IN Tel: 317-773-8323 Fax: 317-773-5453 Tel: 317-536-2380</p> <p>Los Angeles Mission Viejo, CA Tel: 949-462-9523 Fax: 949-462-9608 Tel: 951-273-7800</p> <p>Raleigh, NC Tel: 919-844-7510</p> <p>New York, NY Tel: 631-435-6000</p> <p>San Jose, CA Tel: 408-735-9110 Tel: 408-436-4270</p> <p>Canada - Toronto Tel: 905-695-1980 Fax: 905-695-2078</p>	<p>Australia - Sydney Tel: 61-2-9868-6733</p> <p>China - Beijing Tel: 86-10-8569-7000</p> <p>China - Chengdu Tel: 86-28-8665-5511</p> <p>China - Chongqing Tel: 86-23-8980-9588</p> <p>China - Dongguan Tel: 86-769-8702-9880</p> <p>China - Guangzhou Tel: 86-20-8755-8029</p> <p>China - Hangzhou Tel: 86-571-8792-8115</p> <p>China - Hong Kong SAR Tel: 852-2943-5100</p> <p>China - Nanjing Tel: 86-25-8473-2460</p> <p>China - Qingdao Tel: 86-532-8502-7355</p> <p>China - Shanghai Tel: 86-21-3326-8000</p> <p>China - Shenyang Tel: 86-24-2334-2829</p> <p>China - Shenzhen Tel: 86-755-8864-2200</p> <p>China - Suzhou Tel: 86-186-6233-1526</p> <p>China - Wuhan Tel: 86-27-5980-5300</p> <p>China - Xian Tel: 86-29-8833-7252</p> <p>China - Xiamen Tel: 86-592-2388138</p> <p>China - Zhuhai Tel: 86-756-3210040</p>	<p>India - Bangalore Tel: 91-80-3090-4444</p> <p>India - New Delhi Tel: 91-11-4160-8631</p> <p>India - Pune Tel: 91-20-4121-0141</p> <p>Japan - Osaka Tel: 81-6-6152-7160</p> <p>Japan - Tokyo Tel: 81-3-6880-3770</p> <p>Korea - Daegu Tel: 82-53-744-4301</p> <p>Korea - Seoul Tel: 82-2-554-7200</p> <p>Malaysia - Kuala Lumpur Tel: 60-3-7651-7906</p> <p>Malaysia - Penang Tel: 60-4-227-8870</p> <p>Philippines - Manila Tel: 63-2-634-9065</p> <p>Singapore Tel: 65-6334-8870</p> <p>Taiwan - Hsin Chu Tel: 886-3-577-8366</p> <p>Taiwan - Kaohsiung Tel: 886-7-213-7830</p> <p>Taiwan - Taipei Tel: 886-2-2508-8600</p> <p>Thailand - Bangkok Tel: 66-2-694-1351</p> <p>Vietnam - Ho Chi Minh Tel: 84-28-5448-2100</p>	<p>Austria - Wels Tel: 43-7242-2244-39 Fax: 43-7242-2244-393</p> <p>Denmark - Copenhagen Tel: 45-4485-5910 Fax: 45-4485-2829</p> <p>Finland - Espoo Tel: 358-9-4520-820</p> <p>France - Paris Tel: 33-1-69-53-63-20 Fax: 33-1-69-30-90-79</p> <p>Germany - Garching Tel: 49-8931-9700</p> <p>Germany - Haan Tel: 49-2129-3766400</p> <p>Germany - Heilbronn Tel: 49-7131-72400</p> <p>Germany - Karlsruhe Tel: 49-721-625370</p> <p>Germany - Munich Tel: 49-89-627-144-0 Fax: 49-89-627-144-44</p> <p>Germany - Rosenheim Tel: 49-8031-354-560</p> <p>Israel - Ra'anana Tel: 972-9-744-7705</p> <p>Italy - Milan Tel: 39-0331-742611 Fax: 39-0331-466781</p> <p>Italy - Padova Tel: 39-049-7625286</p> <p>Netherlands - Drunen Tel: 31-416-690399 Fax: 31-416-690340</p> <p>Norway - Trondheim Tel: 47-72884388</p> <p>Poland - Warsaw Tel: 48-22-3325737</p> <p>Romania - Bucharest Tel: 40-21-407-87-50</p> <p>Spain - Madrid Tel: 34-91-708-08-90 Fax: 34-91-708-08-91</p> <p>Sweden - Gothenberg Tel: 46-31-704-60-40</p> <p>Sweden - Stockholm Tel: 46-8-5090-4654</p> <p>UK - Wokingham Tel: 44-118-921-5800 Fax: 44-118-921-5820</p>

X-ON Electronics

Largest Supplier of Electrical and Electronic Components

Click to view similar products for [System-On-Modules - SOM category](#):

Click to view products by [Microchip manufacturer](#):

Other Similar products are found below :

[COMX-CORE-310](#) [COMX-P4040-4G-ENP2](#) [PICOIMX6U10R1GBNI4G](#) [PICOIMX6U10R1GBNI4GBW](#) [RM-F6SO1-SMC](#) [MC27561-TIGER](#) [MC27561-LION](#) [AM335XBBLK-SYSTEM](#) [MC27561-FOX](#) [CC-WMX6UL-SMPL](#) [CB-52-PUS-110-SX](#) [BD63725BEFV-EVK-002](#) [5748-PJ-4AA-RI](#) [5728-PJ-4AA-RI](#) [A00150](#) [COMX_P4080](#) [A20-SOM-EVB](#) [RK3188-SOM](#) [RK3188-SOM-4GB](#) [PICOIMX6Q10R1GBNI4G](#) [PER-TAICX-A10-001](#) [PER-TAIX2-A10-2280](#) [EDL-mPCIe-MA2485](#) [SOM-5897C7-U0A1E](#) [SOM-5897C7-U8A1E](#) [SOM-6896C7-U2A1E](#) [Q7M311-N4200-4GB](#) [SCM180-Dual-2G-Industrial](#) [SCM180-Quad-4G-Industrial](#) [3354-HX-X38-RC](#) [3359-GX-226-RC](#) [5728-PJ-4AA-RC](#) [6455-JE-3X5-RC](#) [ET876-X7LV](#) [IFC6301-10-P2](#) [IFC6502-00-P1](#) [IFC67A1-00-P1](#) [iW-G27M-SCQM-4L008G-E032G-BIG](#) [iW-G33M-SCMQ-4L002G-E008G-BII](#) [PWSE1000200B](#) [CS-DEPTHAI-04](#) [MYC-C7Z020-4E1D-766-I](#) [MYC-C8MMQ6-8E2D-180-C](#) [MYC-Y7Z010-4E512D-667-I](#) [MYD-C4378-4E512D-100-I](#) [MOD5213-100IR](#) [MODM7AE70-100IR](#) [A20-SOM204-1G](#) [A20-SOM204-1GS16ME16G-MC](#) [AM3352-SOM-EVB](#)