

tinyAVR® 2 Family

Introduction

The ATtiny3224/3226/3227 microcontrollers of the tinyAVR® 2 family are using the AVR® CPU with hardware multiplier, running at up to 20 MHz, with 32 KB Flash, 3 KB of SRAM, and 256B of EEPROM available in a 14-, 20-, and 24-pin package. The family uses the latest technologies from Microchip with a flexible and low-power architecture, including an Event System, advanced digital peripherals, and accurate analog features such as a 12-bit differential ADC with Programmable Gain Amplifier (PGA).

tinyAVR® 2 Family Overview

The figure below shows the tinyAVR® 2 family devices, laying out pin count variants and memory sizes.

- Vertical migration is possible without code modification, as these devices are fully pin and feature compatible
- Horizontal migration to the left reduces the pin count and, therefore, the available features

Figure 1. tinyAVR® 2 Family Overview

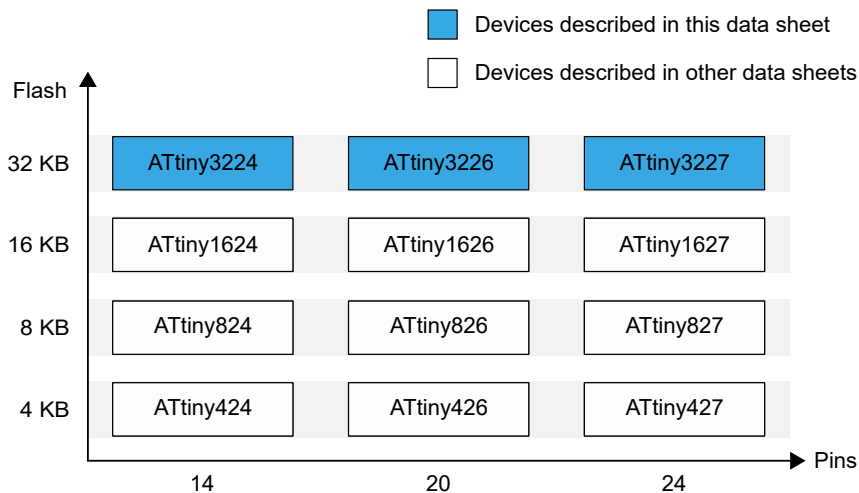

Devices with different flash memory sizes typically also have different SRAM and EEPROM.

The name of a device in the tinyAVR® 2 family is decoded as follows:

Figure 2. tinyAVR® 2 Family Device Designations

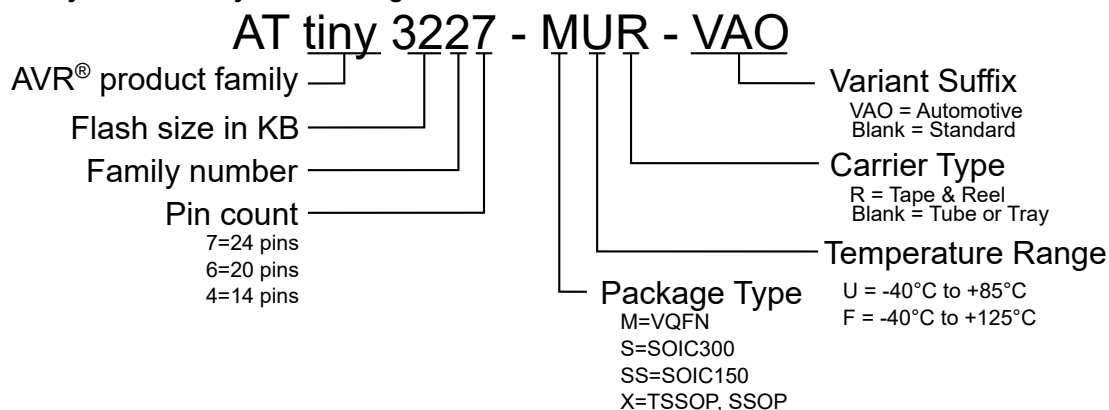

Note: The Tape & Reel identifier only appears in the catalog part number description. Use this identifier for ordering purposes. Check with your Microchip Sales Office for package availability with the Tape and Reel option.

Note: The VAO variants have been designed, manufactured, tested, and qualified per AEC-Q100 requirements for automotive applications. These products may use a different package than non-VAO parts and have additional specifications in their Electrical Characteristics.

Memory Overview

The following table shows the memory overview of the entire family, but further documentation describes only the ATtiny3224/3226/3227 devices.

Table 1. Memory Overview

Device	ATtiny424 ATtiny426 ATtiny427	ATtiny824 ATtiny826 ATtiny827	ATtiny1624 ATtiny1626 ATtiny1627	ATtiny3224 ATtiny3226 ATtiny3227
Flash Memory	4 KB	8 KB	16 KB	32 KB
SRAM	512B	1 KB	2 KB	3 KB
EEPROM	128B	128B	256B	256B
User Row	32B	32B	32B	32B

Peripheral Overview

Table 2. Peripheral Overview

Device	ATtiny3224	ATtiny3226	ATtiny3227
Pins	14	20	24
Package	SOIC, TSSOP	SOIC, SSOP, VQFN	VQFN
Maximum frequency (MHz)	20	20	20
General purpose I/O	12	18	22
PORT	PA[7:0] PB[3:0]	PA[7:0] PB[5:0] PC[3:0]	PA[7:0] PB[7:0] PC[5:0]
External interrupts	12	18	22
Event system channels	6	6	6

.....continued			
Device	ATtiny3224	ATtiny3226	ATtiny3227
CCL LUTs	4	4	4
Real-Time Counter (RTC)	1	1	1
16-bit Timer/Counter type A (TCA)	1	1	1
16-bit Timer/Counter type B (TCB)	2	2	2
12-bit Timer/Counter type D (TCD)	-	-	-
USART/SPI host	2	2	2
SPI	1	1	1
TWI (I ² C)	1	1	1
ADC (channels)	1 (9)	1 (15)	1 (15)
DAC	-	-	-
Analog Comparators (inputs)	1 (2p/2n)	1 (3p/3n)	1 (4p/3n)
Peripheral Touch Controller (PTC) (self cap/mutual cap channels)	-	-	-
Unified Program and Debug Interface (UPDI) activated by shared pin using high-voltage signal or fuse override	1	1	1

Features

- High-Performance Low-Power AVR[®] CPU
 - Running at up to 20 MHz
 - Single-cycle I/O access
 - Two-level interrupt controller with vectored interrupts
 - Two-cycle hardware multiplier
 - Supply voltage range: 1.8V to 5.5V
- Memories
 - 32 KB In-System self-programmable Flash memory
 - 3 KB SRAM
 - 256B EEPROM
 - 32B of user row in nonvolatile memory that can keep data during chip-erase and be programmed while the device is locked
 - Write/erase endurance
 - Flash 10,000 cycles
 - EEPROM 100,000 cycles
 - Data retention: 40 years at 55°C
- System
 - Power-on Reset (POR)
 - Brown-out Detection (BOD)
 - Clock options
 - Lockable 20 MHz Low-Power internal oscillator
 - 32.768 kHz Ultra-Low Power (ULP) internal oscillator
 - 32.768 kHz external crystal oscillator
 - External clock input
 - Single-pin Unified Program and Debug Interface (UPDI)
 - Three sleep modes
 - Idle with all peripherals running and immediate wake-up time
 - Standby with configurable operation of selected peripherals
 - Power-Down with full data retention
- Peripherals
 - One 16-bit Timer/Counter type A (TCA) with a dedicated period register and three PWM channels
 - Two 16-bit Timer/Counters type B (TCB) with input capture and simple PWM functionality
 - One 16-bit Real-Time Counter (RTC) running from external 32.768 kHz crystal or internal 32.768 kHz ULP oscillator
 - Two Universal Synchronous Asynchronous Receiver Transmitters (USART) with fractional baud rate generator, auto-baud, and start-of-frame detection
 - Host/Client Serial Peripheral Interface (SPI)
 - Host/Client Two-Wire Interface (TWI) with dual address match
 - Standard mode (Sm, 100 kHz)
 - Fast mode (Fm, 400 kHz)
 - Fast mode plus (Fm+, 1 MHz)
 - Event System for CPU independent and predictable inter-peripheral signaling
 - Configurable Custom Logic (CCL) with four programmable Look-Up Tables (LUT)
 - One Analog Comparator (AC) with scalable reference input
 - One 12-bit differential 375 ksp/s Analog-to-Digital Converter (ADC) with Programmable Gain Amplifier (PGA) and up to 15 input channels
 - Multiple internal voltage references
 - 1.024V

- 2.048V
- 2.500V
- 4.096V
- VDD
- Automated Cyclic Redundancy Check (CRC) flash memory scan
- Watchdog Timer (WDT) with Window Mode, with a separate on-chip oscillator
- External interrupt on all general purpose pins
- I/O and Packages
 - Up to 22 programmable I/O pins
 - 14-pin
 - SOIC
 - TSSOP
 - 20-pin
 - SOIC
 - SSOP
 - VQFN 3x3 mm
 - 24-pin
 - VQFN 4x4 mm
- Temperature Ranges
 - -40°C to 85°C (industrial)
 - -40°C to 125°C (extended)
- Speed Grades (-40°C to 85°C)
 - 0-5 MHz @ 1.8V – 5.5V
 - 0-10 MHz @ 2.7V – 5.5V
 - 0-20 MHz @ 4.5V – 5.5V
- Speed Grades (-40°C to 125°C)
 - 0-8 MHz @ 2.7V - 5.5V
 - 0-16 MHz @ 4.5V - 5.5V
- VAO variants available: Designed, manufactured, tested, and qualified in accordance with AEC-Q100 requirements for automotive applications.

Table of Contents

Introduction.....	1
tinyAVR® 2 Family Overview.....	1
1. Memory Overview.....	2
2. Peripheral Overview.....	2
Features.....	4
1. Block Diagram.....	13
2. Pinout.....	14
2.1. 14-Pin SOIC, TSSOP.....	14
2.2. 20-Pin SOIC, SSOP.....	15
2.3. 20-Pin VQFN.....	16
2.4. 24-Pin VQFN.....	17
3. I/O Multiplexing and Considerations.....	18
3.1. I/O Multiplexing.....	18
4. Hardware Guidelines.....	19
4.1. General Guidelines.....	19
4.2. Connection for Power Supply.....	19
4.3. Connection for RESET.....	20
4.4. Connection for UPDI Programming.....	21
4.5. Connecting External Crystal Oscillators.....	21
4.6. Connection for External Voltage Reference.....	22
5. Conventions.....	23
5.1. Numerical Notation.....	23
5.2. Memory Size and Type.....	23
5.3. Frequency and Time.....	23
5.4. Registers and Bits.....	24
5.5. ADC Parameter Definitions.....	25
6. AVR® CPU.....	28
6.1. Features.....	28
6.2. Overview.....	28
6.3. Architecture.....	28
6.4. Arithmetic Logic Unit (ALU).....	30
6.5. Functional Description.....	30
6.6. Register Summary.....	34
6.7. Register Description.....	34
7. Memories.....	38
7.1. Overview.....	38
7.2. Memory Map.....	38
7.3. In-System Reprogrammable Flash Program Memory.....	38
7.4. SRAM Data Memory.....	39

7.5.	EEPROM Data Memory.....	39
7.6.	USERROW - User Row.....	40
7.7.	LOCKBIT - Memory Sections Access Protection.....	40
7.8.	FUSE - Configuration and User Fuses.....	43
7.9.	SIGROW - Signature Row.....	51
7.10.	I/O Memory.....	59
8.	Peripherals and Architecture.....	62
8.1.	Peripheral Address Map.....	62
8.2.	Interrupt Vector Mapping.....	63
8.3.	SYSCFG - System Configuration.....	64
9.	General Purpose I/O Registers.....	67
9.1.	Register Summary.....	68
9.2.	Register Description.....	68
10.	NVMCTRL - Nonvolatile Memory Controller.....	70
10.1.	Features.....	70
10.2.	Overview.....	70
10.3.	Functional Description.....	71
10.4.	Register Summary.....	77
10.5.	Register Description.....	77
11.	CLKCTRL - Clock Controller.....	85
11.1.	Features.....	85
11.2.	Overview.....	85
11.3.	Functional Description.....	87
11.4.	Register Summary.....	91
11.5.	Register Description.....	91
12.	SLPCTRL - Sleep Controller.....	101
12.1.	Features.....	101
12.2.	Overview.....	101
12.3.	Functional Description.....	101
12.4.	Register Summary.....	105
12.5.	Register Description.....	105
13.	RSTCTRL - Reset Controller.....	107
13.1.	Features.....	107
13.2.	Overview.....	107
13.3.	Functional Description.....	108
13.4.	Register Summary.....	112
13.5.	Register Description.....	112
14.	CPUINT - CPU Interrupt Controller.....	115
14.1.	Features.....	115
14.2.	Overview.....	115
14.3.	Functional Description.....	116
14.4.	Register Summary.....	121

14.5. Register Description.....	121
15. EVSYS - Event System.....	126
15.1. Features.....	126
15.2. Overview.....	126
15.3. Functional Description.....	127
15.4. Register Summary.....	133
15.5. Register Description.....	133
16. PORTMUX - Port Multiplexer.....	139
16.1. Overview.....	139
16.2. Register Summary.....	140
16.3. Register Description.....	140
17. PORT - I/O Pin Configuration.....	147
17.1. Features.....	147
17.2. Overview.....	147
17.3. Functional Description.....	149
17.4. Register Summary - PORTx.....	153
17.5. Register Description - PORTx.....	153
17.6. Register Summary - VPORTx.....	166
17.7. Register Description - VPORTx.....	166
18. BOD - Brown-out Detector.....	171
18.1. Features.....	171
18.2. Overview.....	171
18.3. Functional Description.....	172
18.4. Register Summary.....	174
18.5. Register Description.....	174
19. VREF - Voltage Reference.....	181
19.1. Features.....	181
19.2. Overview.....	181
19.3. Functional Description.....	181
19.4. Register Summary.....	183
19.5. Register Description.....	183
20. WDT - Watchdog Timer	186
20.1. Features.....	186
20.2. Overview.....	186
20.3. Functional Description.....	187
20.4. Register Summary.....	190
20.5. Register Description.....	190
21. TCA - 16-bit Timer/Counter Type A.....	194
21.1. Features.....	194
21.2. Overview.....	194
21.3. Functional Description.....	196
21.4. Register Summary - Normal Mode.....	208

21.5. Register Description - Normal Mode.....	208
21.6. Register Summary - Split Mode.....	227
21.7. Register Description - Split Mode.....	227
22. TCB - 16-Bit Timer/Counter Type B.....	243
22.1. Features.....	243
22.2. Overview.....	243
22.3. Functional Description.....	245
22.4. Register Summary.....	255
22.5. Register Description.....	255
23. RTC - Real-Time Counter.....	266
23.1. Features.....	266
23.2. Overview.....	266
23.3. Clocks.....	267
23.4. RTC Functional Description.....	267
23.5. PIT Functional Description.....	268
23.6. Crystal Error Correction.....	270
23.7. Events.....	270
23.8. Interrupts.....	271
23.9. Sleep Mode Operation.....	272
23.10. Synchronization.....	272
23.11. Debug Operation.....	272
23.12. Register Summary.....	273
23.13. Register Description.....	273
24. USART - Universal Synchronous and Asynchronous Receiver and Transmitter.....	290
24.1. Features.....	290
24.2. Overview.....	290
24.3. Functional Description.....	291
24.4. Register Summary.....	306
24.5. Register Description.....	306
25. SPI - Serial Peripheral Interface.....	324
25.1. Features.....	324
25.2. Overview.....	324
25.3. Functional Description.....	325
25.4. Register Summary.....	332
25.5. Register Description.....	332
26. TWI - Two-Wire Interface.....	339
26.1. Features.....	339
26.2. Overview.....	339
26.3. Functional Description.....	340
26.4. Register Summary.....	351
26.5. Register Description.....	351
27. CRCSCAN - Cyclic Redundancy Check Memory Scan.....	368
27.1. Features.....	368

27.2. Overview.....	368
27.3. Functional Description.....	369
27.4. Register Summary.....	372
27.5. Register Description.....	372
28. CCL - Configurable Custom Logic.....	376
28.1. Features.....	376
28.2. Overview.....	376
28.3. Functional Description.....	378
28.4. Register Summary	386
28.5. Register Description.....	386
29. AC - Analog Comparator.....	396
29.1. Features.....	396
29.2. Overview.....	396
29.3. Functional Description.....	397
29.4. Register Summary.....	399
29.5. Register Description.....	399
30. ADC - Analog-to-Digital Converter.....	405
30.1. Features.....	405
30.2. Overview.....	405
30.3. Functional Description.....	406
30.4. Register Summary.....	420
30.5. Register Description.....	420
31. UPDI - Unified Program and Debug Interface.....	440
31.1. Features.....	440
31.2. Overview.....	440
31.3. Functional Description.....	442
31.4. Register Summary.....	462
31.5. Register Description.....	462
32. Instruction Set Summary.....	473
33. Electrical Characteristics.....	474
33.1. Disclaimer.....	474
33.2. Absolute Maximum Ratings	474
33.3. General Operating Ratings	475
33.4. Power Considerations.....	476
33.5. Power Consumption	477
33.6. Wake-Up Time.....	478
33.7. Peripherals Power Consumption.....	479
33.8. BOD and POR Characteristics.....	480
33.9. External Reset Characteristics.....	481
33.10. Oscillators and Clocks.....	481
33.11. I/O Pin Characteristics.....	483
33.12. USART.....	485
33.13. SPI.....	486

33.14. TWI.....	487
33.15. VREF.....	490
33.16. ADC.....	491
33.17. TEMPSENSE.....	493
33.18. AC.....	493
33.19. UPDI.....	494
33.20. Programming Time.....	495
34. Typical Characteristics.....	496
34.1. Power Consumption.....	496
34.2. GPIO.....	506
34.3. VREF Characteristics.....	514
34.4. BOD Characteristics.....	515
34.5. ADC Characteristics.....	518
34.6. TEMPSENSE Characteristics.....	531
34.7. AC Characteristics.....	531
34.8. OSC20M Characteristics.....	537
34.9. OSCULP32K Characteristics.....	539
35. Ordering Information.....	541
36. Package Drawings.....	543
36.1. Online Package Drawings.....	543
36.2. Package Marking Information.....	543
36.3. 14-Pin SOIC.....	547
36.4. 14-Pin TSSOP.....	550
36.5. 20-Pin SOIC.....	553
36.6. 20-Pin SSOP.....	556
36.7. 20-Pin VQFN.....	558
36.8. 20-Pin VQFN Wettable Flanks.....	561
36.9. 24-Pin VQFN.....	564
36.10. 24-Pin VQFN Wettable Flanks.....	567
37. Data Sheet Revision History.....	570
37.1. Rev.B - 12/2021.....	570
37.2. Rev.A - 09/2021.....	570
The Microchip Website.....	571
Product Change Notification Service.....	571
Customer Support.....	571
Product Identification System.....	572
Microchip Devices Code Protection Feature.....	572
Legal Notice.....	572
Trademarks.....	573
Quality Management System.....	573

Worldwide Sales and Service.....574

1. Block Diagram

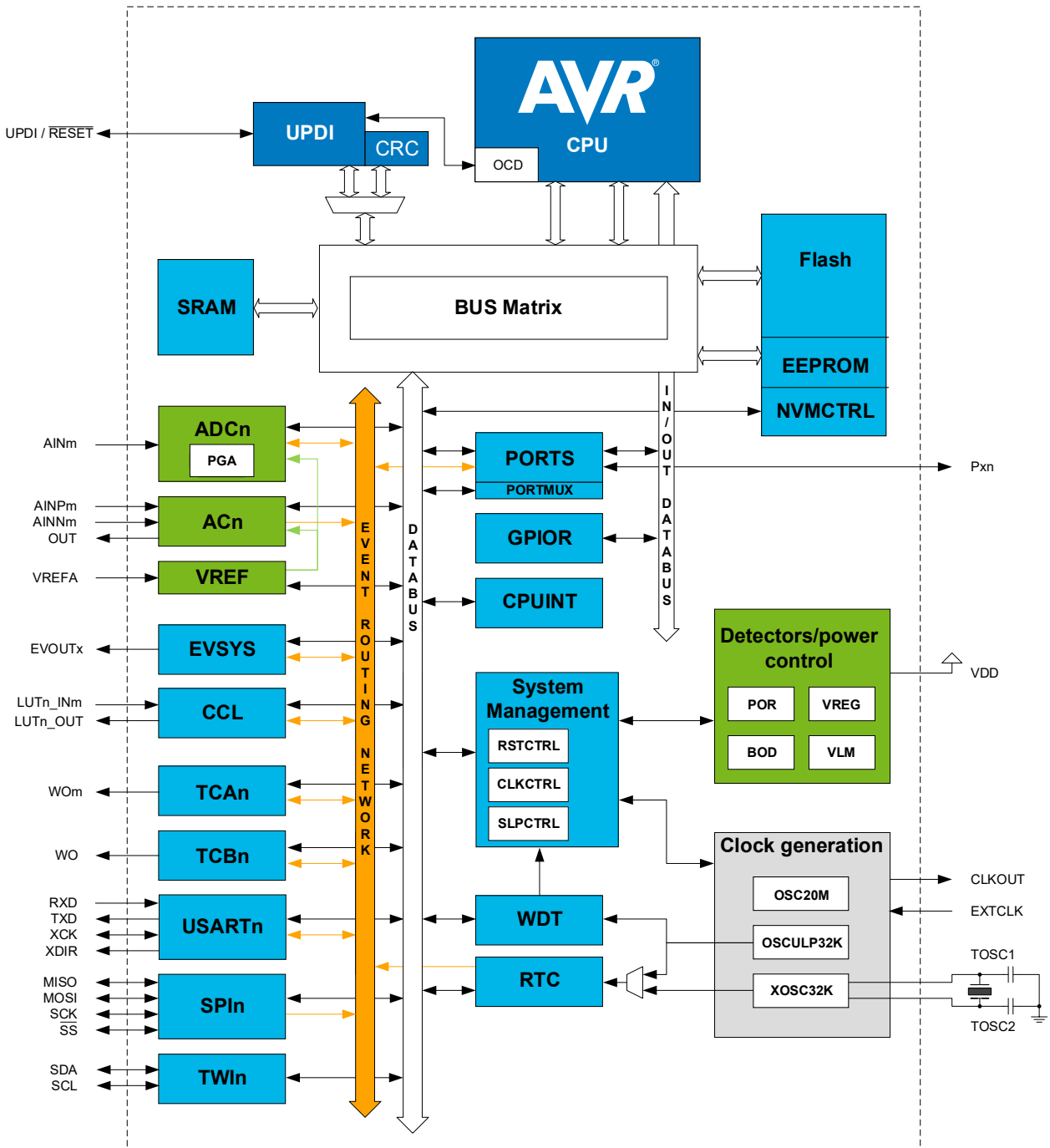



2. Pinout

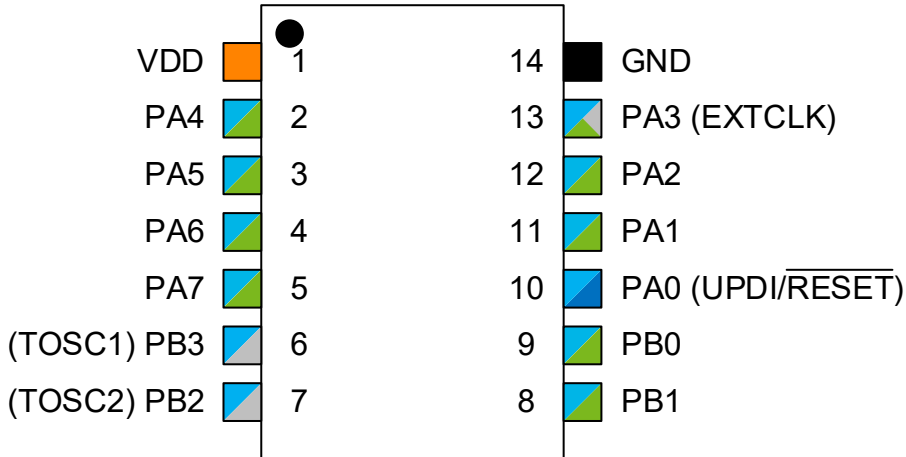

2.1 14-Pin SOIC, TSSOP



Power

-  Power Supply
-  Ground
-  Pin on VDD Power Domain

Functionality

-  Programming/Debug
-  Clock/Crystal
-  Analog Function

2.2 20-Pin SOIC, SSOP

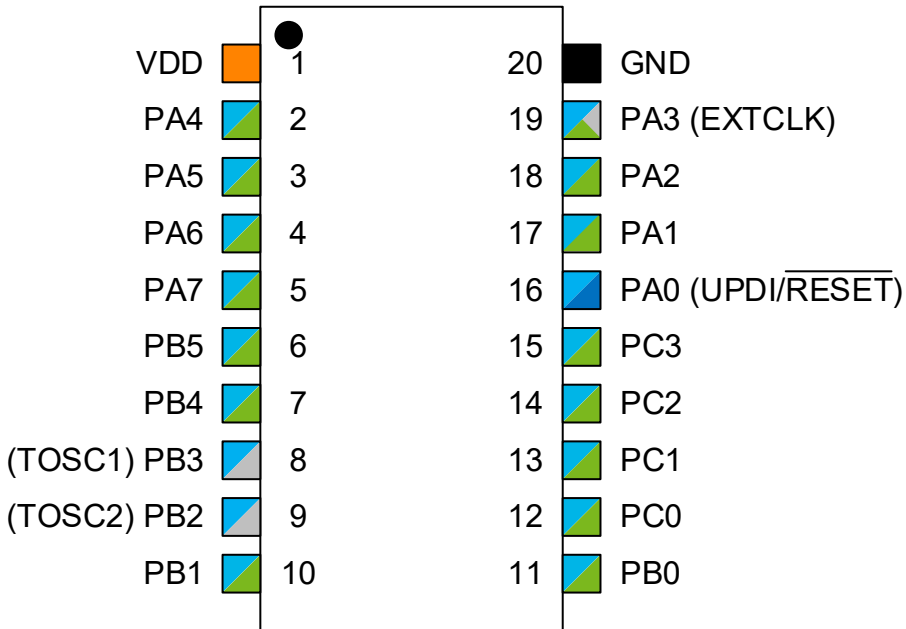

Power

 Power Supply

 Ground

 Pin on VDD Power Domain

Functionality

 Programming/Debug



 Clock/Crystal

 Analog Function

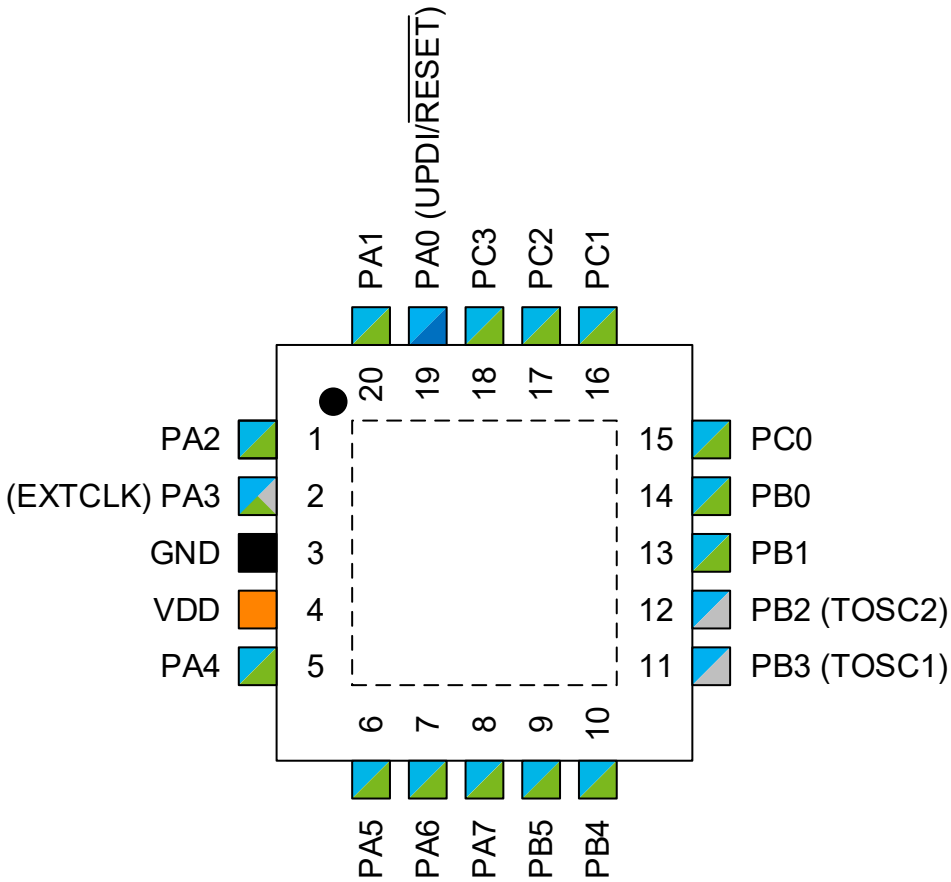

2.3 20-Pin VQFN



Power

-  Power Supply
-  Ground
-  Pin on VDD Power Domain



Functionality

-  Programming/Debug
-  Clock/Crystal
-  Analog Function

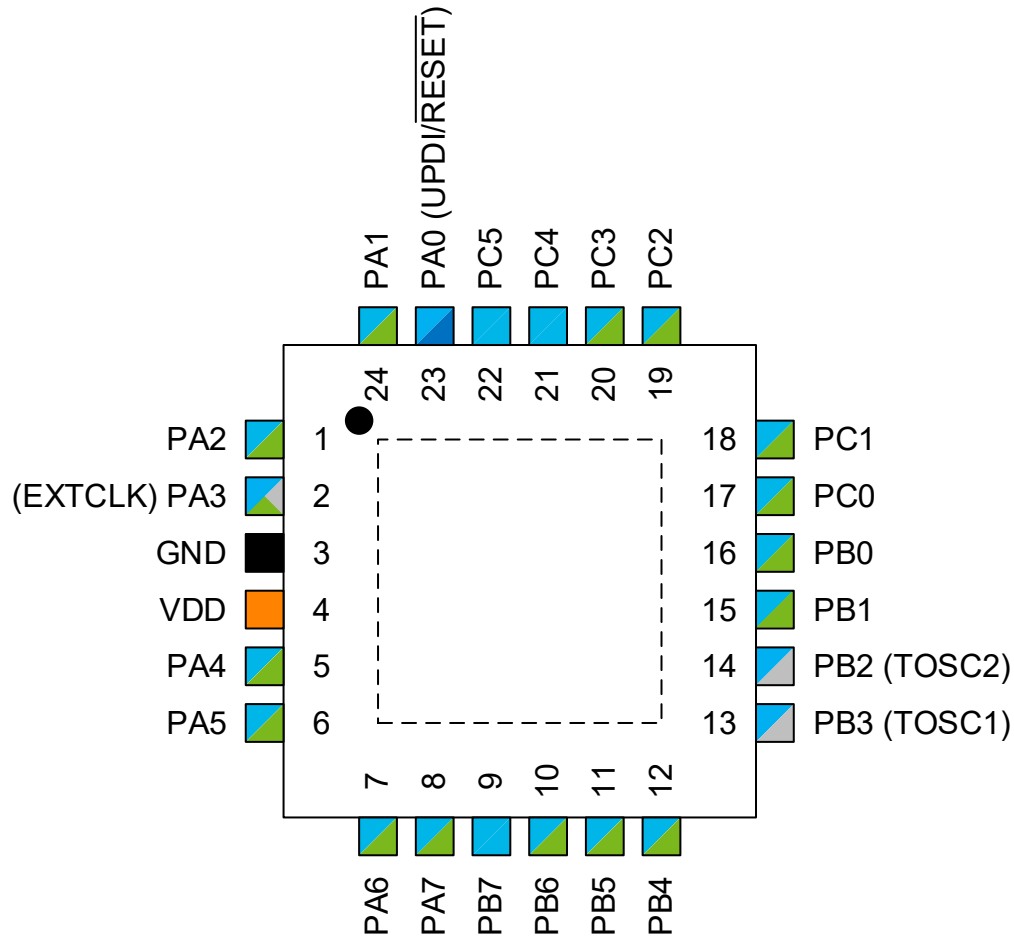



2.4 24-Pin VQFN



Power

-  Power Supply
-  Ground
-  Pin on VDD Power Domain

Functionality

-  Programming/Debug
-  Clock/Crystal
-  Analog Function
-  Digital Function Only

3. I/O Multiplexing and Considerations

3.1 I/O Multiplexing

Table 3-1. PORT Function Multiplexing

VQFN 24-pin	VQFN 20-pin	SSOP/SOIC 20-pin	TSSOP/SOIC 14-pin	Pin Name (1,2)	Other/Special	ADC0 ⁽³⁾	AC0	USART0	USART1	SPI0	TWI0	TCA0	TCBn	CCL
23	19	16	10	PA0	RESET UPDI									LUT0-IN0
24	20	17	11	PA1		AIN1		TXD ⁽⁴⁾	TXD	MOSI				LUT0-IN1
1	1	18	12	PA2	EVOUTA	AIN2		RxD ⁽⁴⁾	RXD	MISO				LUT0-IN2
2	2	19	13	PA3	EXTCLK	AIN3		XCK ⁽⁴⁾	XCK	SCK		WO3	1,WO	
3	3	20	14	GND										
4	4	1	1	VDD										
5	5	2	2	PA4		AIN4		XDIR ⁽⁴⁾	XDIR	SS		WO4		LUT0-OUT
6	6	3	3	PA5	VREFA	AIN5	OUT					WO5	0,WO	LUT3-OUT ⁽⁴⁾
7	7	4	4	PA6		AIN6	AINN0							
8	8	5	5	PA7	EVOUTA ⁽⁴⁾	AIN7	AINP0							LUT1-OUT
9				PB7	EVOUTA ⁽⁴⁾									
10				PB6			AINP3							LUT2-OUT ⁽⁴⁾
11	9	6		PB5	CLKOUT	AIN8	AINP1					WO2 ⁽⁴⁾		
12	10	7		PB4	RESET ⁽⁴⁾	AIN9	AINN1					WO1 ⁽⁴⁾		LUT0-OUT
13	11	8	6	PB3	TOSC1			RxD				WO0 ⁽⁴⁾		LUT2-OUT
14	12	9	7	PB2	TOSC2 EVOUTA			TxD				WO2		LUT2-IN2
15	13	10	8	PB1		AIN10	AINP2	XCK			SDA	WO1		LUT2-IN1
16	14	11	9	PB0		AIN11	AINN2	XDIR			SCL	WO0		LUT2-IN0
17	15	12		PC0		AIN12			XCK ⁽⁴⁾	SCK ⁽⁴⁾			0,WO ⁽⁴⁾	LUT3-IN0
18	16	13		PC1		AIN13			RxD ⁽⁴⁾	MISO ⁽⁴⁾				LUT1-OUT ⁽⁴⁾ LUT3-IN1
19	17	14		PC2	EVOUTC	AIN14			TxD ⁽⁴⁾	MOSI ⁽⁴⁾				LUT3-IN2
20	18	15		PC3		AIN15			XDIR ⁽⁴⁾	SS ⁽⁴⁾		WO3 ⁽⁴⁾		LUT1-IN0
21				PC4								WO4 ⁽⁴⁾	1,WO ⁽⁴⁾	LUT1-IN1 LUT3-OUT
22				PC5								WO5 ⁽⁴⁾		LUT1-IN2

Notes:

- Pin names are of type Pxn with x being the PORT instance (A, B) and n the pin number. Notation for signals is PORTx_PINn.
- All pins can be used for external interrupt where pins Px2 and Px6 of each port have full asynchronous detection. All pins can be used as event input.
- AIN[15:8] can not be used as negative ADC input for differential measurements.
- Alternative pin location. For selecting an alternative pin location, refer to the PORTMUX section.

4. Hardware Guidelines

This section contains guidelines for designing or reviewing electrical schematics using AVR 8-bit microcontrollers. The information presented here is a brief overview of the most common topics. More detailed information can be found in application notes, listed in this section where applicable.

This section covers the following topics:

- General guidelines
- Connection for power supply
- Connection for RESET
- Connection for UPDI (Unified Program and Debug Interface)
- Connection for external crystal oscillators
- Connection for VREF (external voltage reference)

4.1 General Guidelines

Unused pins must be soldered to their respective soldering pads. The soldering pads must not be connected to the circuit.

The PORT pins are in their default state after Reset. Follow the recommendations in the *PORT* section to reduce power consumption.

All values are given as typical values and serve only as a starting point for circuit design.

Refer to the following application notes for further information:

- *AVR040 - EMC Design Considerations*
- *AVR042 - AVR Hardware Design Considerations*

4.1.1 Special Consideration for Packages with Center Pad

Flat packages often come with an exposed pad located on the bottom, often referred to as the center pad or the thermal pad. This pad is not electrically connected to the internal circuit of the chip, but it is mechanically bonded to the internal substrate and serves as a thermal heat sink as well as providing added mechanical stability. This pad must be connected to GND since the ground plane is the best heat sink (largest copper area) of the printed circuit board (PCB).

4.2 Connection for Power Supply

The basics and details regarding the design of the power supply itself lie beyond the scope of these guidelines. For more detailed information about this subject, see the application notes mentioned at the beginning of this section.

A decoupling capacitor must be placed close to the microcontroller for each supply pin pair (VDD, AVDD, or other power supply pin and its corresponding GND pin). If the decoupling capacitor is placed too far from the microcontroller, a high-current loop might form that will result in increased noise and increased radiated emission.

Each supply pin pair (power input pin and ground pin) must have separate decoupling capacitors.

It is recommended to place the decoupling capacitor on the same side of the PCB as the microcontroller. If space does not allow it, the decoupling capacitor may be placed on the other side through a via, but make sure the distance to the supply pin is kept as short as possible.

If the board is experiencing high-frequency noise (upward of tens of MHz), add a second ceramic type capacitor in parallel to the decoupling capacitor described above. Place this second capacitor next to the primary decoupling capacitor.

On the board layout from the power supply circuit, run the power and return traces to the decoupling capacitors first, and then to the device pins. This ensures that the decoupling capacitors are first in the power chain. Equally important is to keep the trace length between the capacitor and the power pins to a minimum, thereby reducing PCB trace inductance.

As mentioned at the beginning of this section, all values used in examples are typical values. The actual design may require other values.

4.2.1 Digital Power Supply

For larger pin count package types, there are several VDD and corresponding GND pins. All the VDD pins in the microcontroller are internally connected. The same voltage must be applied to each of the VDD pins.

The following figure shows the recommendation for connecting a power supply to the VDD pin(s) of the device.

Figure 4-1. Recommended VDD Connection Circuit Schematic

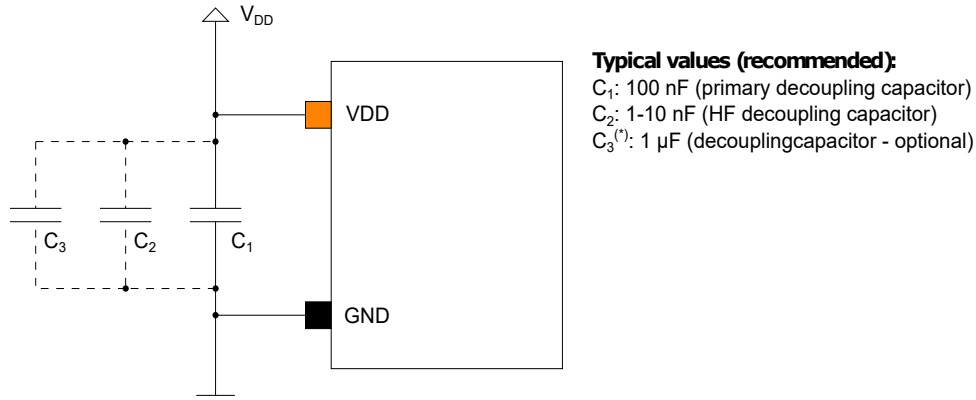

Important: For systems that frequently cycle V_{DD} or experience fast V_{DD} transients, it is recommended to add an additional decoupling capacitor (C_3) if the power supply slew rate exceeds the slew rate limits. Refer to the *Supply Voltage* section in the *Electrical Characteristics* for details about power supply slew rate limits.

4.3 Connection for $\overline{\text{RESET}}$

The $\overline{\text{RESET}}$ pin on the device is active-low, and setting the pin low externally will result in a Reset of the device.

AVR devices feature an internal pull-up resistor on the $\overline{\text{RESET}}$ pin, and an external pull-up resistor is usually not required.

The following figure shows the recommendation for connecting an external Reset switch to the device.

Figure 4-2. Recommended External Reset Circuit Schematic

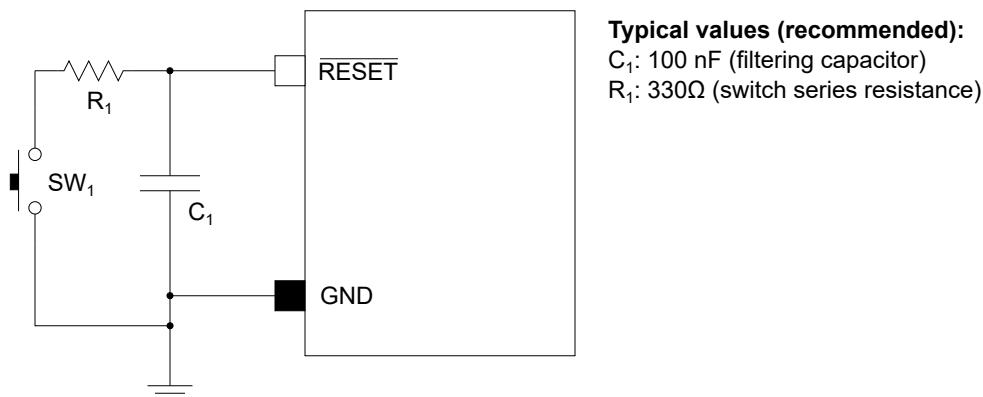

A resistor in series with the switch can safely discharge the filtering capacitor. This prevents a current surge when shorting the filtering capacitor, as this may cause a noise spike that can harm the system.

4.4 Connection for UPDI Programming

The standard connection for UPDI programming is a 100-mil 6-pin 2x3 header. Even though three pins are sufficient for programming most AVR devices, it is recommended to use a 2x3 header since most programming tools are delivered with 100-mil 6-pin 2x3 connectors.

The following figure shows the recommendation for connecting a UPDI connector to the device.

Figure 4-3. Recommended UPDI Programming Circuit Schematic

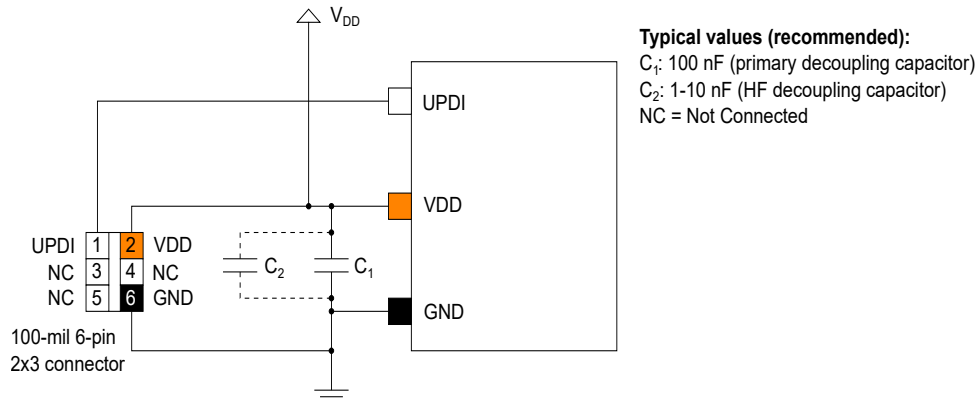

The decoupling capacitor between VDD and GND must be placed as close to the pin pair as possible. The decoupling capacitor must be included even if the UPDI connector is not included in the circuit.

4.5 Connecting External Crystal Oscillators

The use of external oscillators and the design of oscillator circuits are not trivial. This is because there are many variables: V_{DD} , operating temperature range, crystal type and manufacture, loading capacitors, circuit layout, and PCB material. In this section, some typical guidelines to help with the basic oscillator circuit design are presented.

- Even the best performing oscillator circuits and high-quality crystals will not perform well if the layout and materials used during the assembly are not carefully considered
- The crystal circuit must be placed on the same side of the board as the device. Place the crystal circuit as close to the respective oscillator pins as possible and avoid long traces. This will reduce parasitic capacitance and increase immunity against noise and crosstalk. Mount the load capacitors next to the crystal and on the same side of the board. Do not use sockets.
- Place a grounded copper area around the crystal circuit to isolate it from surrounding circuits. If the circuit board has two sides, the copper area on the bottom layer must be a solid area covering the crystal circuit. The copper area on the top layer must surround the crystal circuit and be connected to the bottom layer area by use of via(s).
- Do not run any signal traces or power traces inside the grounded copper area. Avoid routing digital lines, especially clock lines, close to the crystal lines.
- If using a two-sided PCB, avoid any traces beneath the crystal. For a multilayer PCB, avoid routing signals below the crystal lines.
- Dust and humidity will increase parasitic capacitance and reduce signal isolation. A protective coating is recommended.
- Successful oscillator design requires good specifications of operating conditions, a component selection phase with initial testing, and testing in actual operating conditions to ensure that the oscillator performs as desired

For more detailed information about oscillators and oscillator circuit design, see the following application notes:

- *AN2648 - Selecting and Testing 32 kHz Crystal Oscillators for AVR® Microcontrollers*
- *AN949 - Making Your Oscillator Work*

4.5.1 Connection for XOSC32K (External 32.768 kHz Crystal Oscillator)

Ultra-low power 32.768 kHz oscillators typically dissipate significantly below 1 μ W, and the current flowing in the circuit is, therefore, extremely small. The crystal frequency is highly dependent on the capacitive load.

The following figure shows how to connect an external 32.768 kHz crystal oscillator.

Figure 4-4. Recommended External 32.768 kHz Oscillator Connection Circuit Schematic

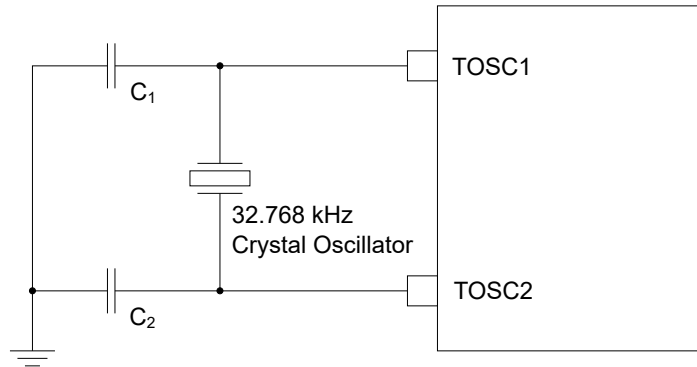

4.6 Connection for External Voltage Reference

If the design includes using an external voltage reference, the general recommendation is to use a suitable capacitor connected in parallel to the reference. The nature of the reference and the type of electrical noise that needs to be filtered out gives the capacitor value.

Additional filtering components may be necessary and depends on the type of external voltage reference used.

Figure 4-5. Recommended External Voltage Reference Connection

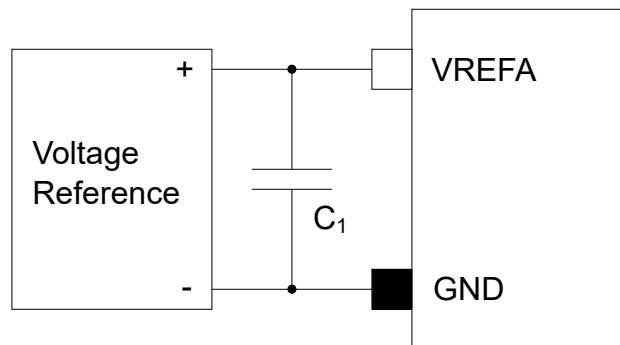

5. Conventions

5.1 Numerical Notation

Table 5-1. Numerical Notation

Symbol	Description
165	Decimal number
0b0101	Binary number
'0101'	Binary numbers are given without prefix if unambiguous
0x3B24	Hexadecimal number
X	Represents an unknown or do not care value
Z	Represents a high-impedance (floating) state for either a signal or a bus

5.2 Memory Size and Type

Table 5-2. Memory Size and Bit Rate

Symbol	Description
KB	kilobyte ($2^{10}\text{B} = 1024\text{B}$)
MB	megabyte ($2^{20}\text{B} = 1024\text{KB}$)
GB	gigabyte ($2^{30}\text{B} = 1024\text{MB}$)
b	bit (binary '0' or '1')
B	byte (8 bits)
1 kbit/s	1,000 bit/s rate
1 Mbit/s	1,000,000 bit/s rate
1 Gbit/s	1,000,000,000 bit/s rate
word	16-bit

5.3 Frequency and Time

Table 5-3. Frequency and Time

Symbol	Description
kHz	1 kHz = $10^3\text{ Hz} = 1,000\text{ Hz}$
MHz	1 MHz = $10^6\text{ Hz} = 1,000,000\text{ Hz}$
GHz	1 GHz = $10^9\text{ Hz} = 1,000,000,000\text{ Hz}$
ms	1 ms = $10^{-3}\text{ s} = 0.001\text{ s}$
μs	1 $\mu\text{s} = 10^{-6}\text{ s} = 0.000001\text{ s}$
ns	1 ns = $10^{-9}\text{ s} = 0.000000001\text{ s}$

5.4 Registers and Bits

Table 5-4. Register and Bit Mnemonics

Symbol	Description
R/W	Read/Write accessible register bit. The user can read from and write to this bit.
R	Read-only accessible register bit. The user can only read this bit. Writes will be ignored.
W	Write-only accessible register bit. The user can only write this bit. Reading this bit will return an undefined value.
BITFIELD	Bitfield names are shown in uppercase. Example: INTMODE.
BITFIELD[n:m]	A set of bits from bit n down to m. Example: PINA[3:0] = {PINA3, PINA2, PINA1, PINA0}.
Reserved	Reserved bits, bit fields, and bit field values are unused and reserved for future use. For compatibility with future devices, always write reserved bits to '0' when the register is written. Reserved bits will always return zero when read.
PERIPHERALn	If several instances of the peripheral exist, the peripheral name is followed by a single number to identify one instance. Example: USARTn is the collection of all instances of the USART module, while USART3 is one specific instance of the USART module.
PERIPHERALx	If several instances of the peripheral exist, the peripheral name is followed by a single capital letter (A-Z) to identify one instance. Example: PORTx is the collection of all instances of the PORT module, while PORTB is one specific instance of the PORT module.
Reset	Value of a register after a Power-on Reset. This is also the value of registers in a peripheral after performing a software Reset of the peripheral, except for the Debug Control registers.
SET/CLR/TGL	Registers with SET/CLR/TGL suffix allow the user to clear and set bits in a register without doing a read-modify-write operation. Each SET/CLR/TGL register is paired with the register it is affecting. Both registers in a register pair return the same value when read. Example: In the PORT peripheral, the OUT and OUTSET registers form such a register pair. The contents of OUT will be modified by a write to OUTSET. Reading OUT and OUTSET will return the same value. Writing a '1' to a bit in the CLR register will clear the corresponding bit in both registers. Writing a '1' to a bit in the SET register will set the corresponding bit in both registers. Writing a '1' to a bit in the TGL register will toggle the corresponding bit in both registers.

5.4.1 Addressing Registers from Header Files

In order to address registers in the supplied C header files, the following rules apply:

1. A register is identified by <peripheral_instance_name>.<register_name>, e.g., CPU.SREG, USART2.CTRLA, or PORTB.DIR.
2. The peripheral name is given in the "Peripheral Address Map" in the "Peripherals and Architecture" section.
3. <peripheral_instance_name> is obtained by substituting any n or x in the peripheral name with the correct instance identifier.
4. When assigning a predefined value to a peripheral register, the value is constructed following the rule:
<peripheral_name>_<bit_field_name>_<bit_field_value>_gc
<peripheral_name> is <peripheral_instance_name>, but remove any instance identifier.

<bit_field_value> can be found in the "Name" column in the tables in the Register Description sections describing the bit fields of the peripheral registers.

Example 5-1. Register Assignments

```
// EVSYS channel 0 is driven by TCB3 OVF event
EVSYS.CHANNEL0 = EVSYS_CHANNEL0_TCB3_OVF_gc;

// USART0 RXMODE uses Double Transmission Speed
USART0.CTRLB = USART_RXMODE_CLK2X_gc;
```

Note: For peripherals with different register sets in different modes, <peripheral_instance_name> and <peripheral_name> must be followed by a mode name, for example:

```
// TCA0 in Normal Mode (SINGLE) uses waveform generator in frequency mode
TCA0.SINGLE.CTRL=TCA_SINGLE_WGMODE_FRQ_gc;
```

5.5 ADC Parameter Definitions

An ideal n-bit single-ended ADC converts a voltage linearly between GND and V_{REF} in 2^n steps (LSb). The lowest code is read as '0', and the highest code is read as ' 2^n-1 '. Several parameters describe the deviation from the ideal behavior:

Offset Error

The deviation of the first transition (0x000 to 0x001) compared to the ideal transition (at 0.5 LSb). Ideal value: 0 LSb.

Figure 5-1. Offset Error

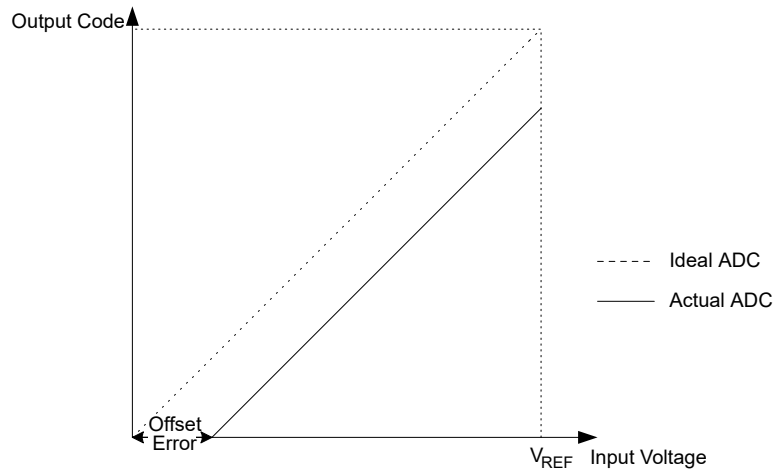

Gain Error

After adjusting for offset, the gain error is found as the deviation of the last transition (e.g., 0x3FE to 0x3FF for a 10-bit ADC) compared to the ideal transition (at 1.5 LSb below maximum). Ideal value: 0 LSb.

Figure 5-2. Gain Error

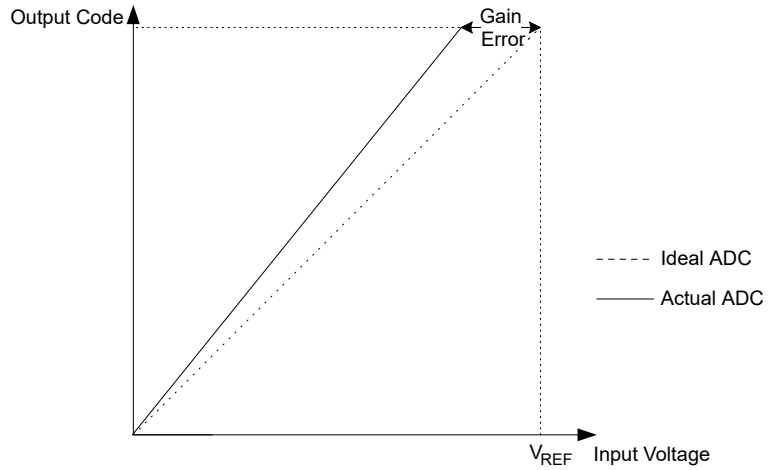

Integral Nonlinearity (INL)

After adjusting for offset and gain error, the INL is the maximum deviation of an actual transition compared to an ideal transition for any code. Ideal value: 0 LSb.

Figure 5-3. Integral Nonlinearity

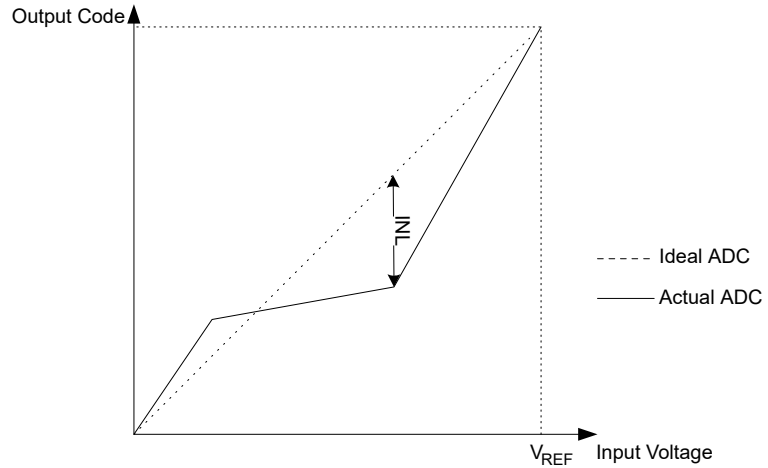

Differential Nonlinearity (DNL)

The maximum deviation of the actual code width (the interval between two adjacent transitions) from the ideal code width (1 LSb). Ideal value: 0 LSb.

Figure 5-4. Differential Nonlinearity

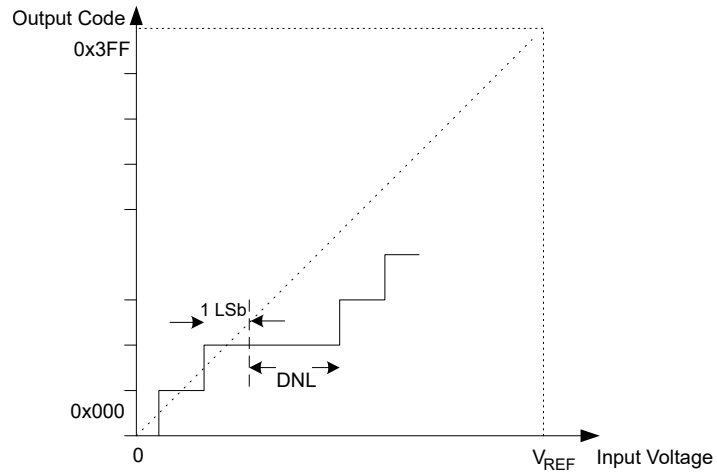

Quantization Error Due to the quantization of the input voltage into a finite number of codes, a range of input voltages (1 LSb wide) will code to the same value. Always ± 0.5 LSb.

Absolute Accuracy The maximum deviation of an actual (unadjusted) transition compared to an ideal transition for any code. This is the compound effect of all errors mentioned before. Ideal value: ± 0.5 LSb.

6. AVR® CPU

6.1 Features

- 8-Bit, High-Performance AVR RISC CPU:
 - 135 instructions
 - Hardware multiplier
- 32 8-Bit Registers Directly Connected to the ALU
- Stack in RAM
- Stack Pointer Accessible in I/O Memory Space
- Direct Addressing of up to 64 KB of Unified Memory
- Efficient Support for 8-, 16-, and 32-Bit Arithmetic
- Configuration Change Protection for System-Critical Features
- Native On-Chip Debugging (OCD) Support:
 - Two hardware breakpoints
 - Change of flow, interrupt, and software breakpoints
 - Run-time read-out of Stack Pointer (SP) register, Program Counter (PC), and Status Register (SREG)
 - Register file read- and writable in Stopped mode

6.2 Overview

The AVR CPU can access memories, perform calculations, control peripherals, execute instructions from the program memory, and handle interrupts.

6.3 Architecture

To maximize performance and parallelism, the AVR CPU uses a Harvard architecture with separate buses for program and data. The instructions in the program memory are executed with a single-level pipeline. While one instruction is being executed, the next instruction is prefetched from the program memory. This enables instructions to be executed on every clock cycle.

Refer to the *Instruction Set Summary* section for a summary of all AVR instructions.

Figure 6-1. AVR® CPU Architecture

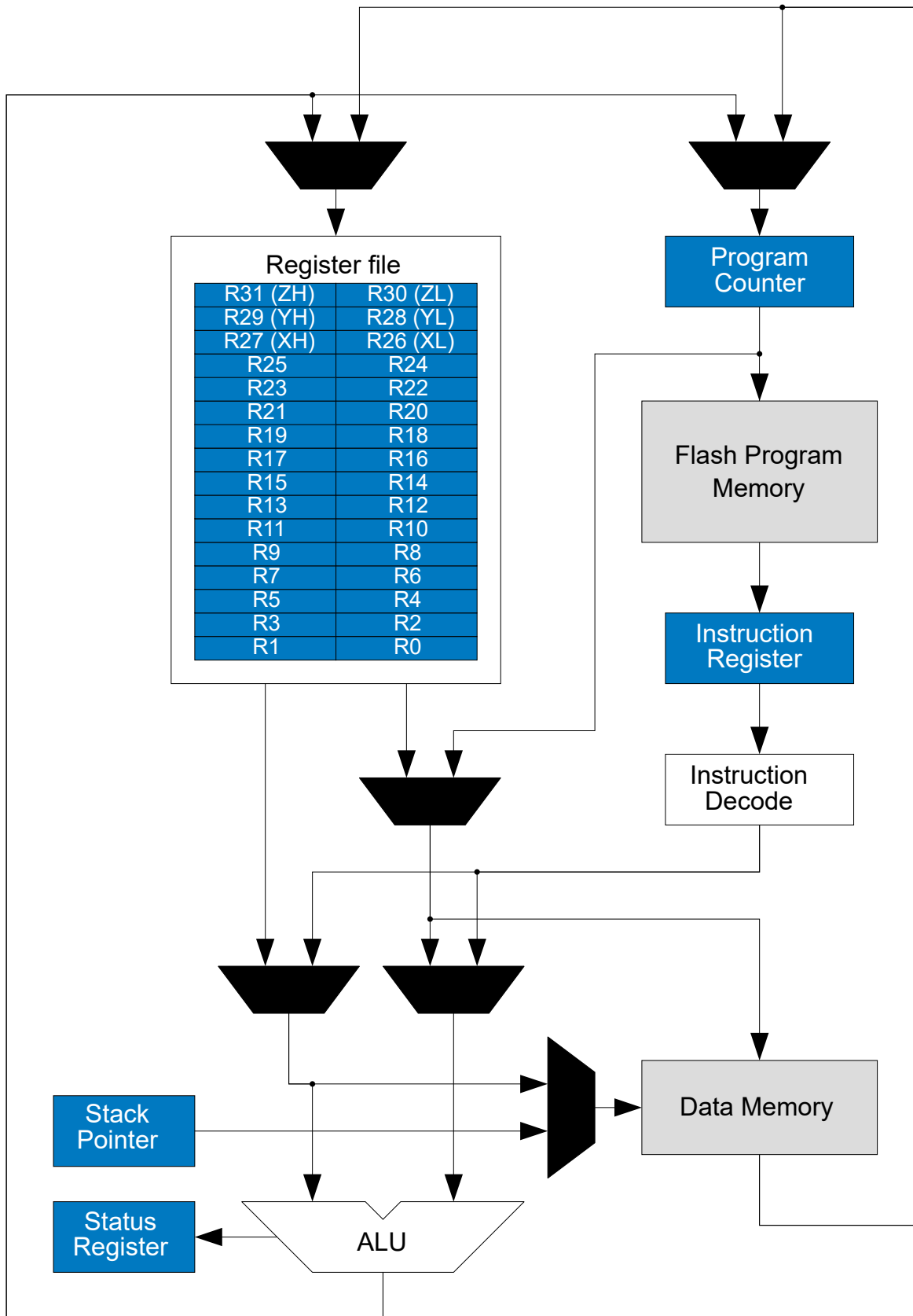

6.4 Arithmetic Logic Unit (ALU)

The Arithmetic Logic Unit (ALU) supports arithmetic and logic operations between working registers or between a constant and a working register. Also, single-register operations can be executed.

The ALU operates in a direct connection with all the 32 general purpose working registers in the register file. The arithmetic operations between working registers or between a working register and an immediate operand are executed in a single clock cycle, and the result is stored in the register file. After an arithmetic or logic operation, the Status Register (CPU.SREG) is updated to reflect information about the result of the operation.

ALU operations are divided into three main categories – arithmetic, logical, and bit functions. Both 8- and 16-bit arithmetic are supported, and the instruction set allows for an efficient implementation of the 32-bit arithmetic. The hardware multiplier supports signed and unsigned multiplication and fractional formats.

6.4.1 Hardware Multiplier

The multiplier is capable of multiplying two 8-bit numbers into a 16-bit result. The hardware multiplier supports different variations of signed and unsigned integer and fractional numbers:

- Multiplication of signed/unsigned integers
- Multiplication of signed/unsigned fractional numbers
- Multiplication of a signed integer with an unsigned integer
- Multiplication of a signed fractional number with an unsigned fractional number

A multiplication takes two CPU clock cycles.

6.5 Functional Description

6.5.1 Program Flow

After being reset, the CPU will execute instructions from the lowest address in the Flash program memory, 0x0000. The Program Counter (PC) addresses the next instruction to be fetched.

The CPU supports instructions that can change the program flow conditionally or unconditionally and are capable of addressing the whole address space directly. Most AVR instructions use a 16-bit word format, and a limited number use a 32-bit format.

During interrupts and subroutine calls, the return address PC is stored on the stack as a word pointer. The stack is allocated in the general data SRAM, and consequently, the stack size is only limited by the total SRAM size and the usage of the SRAM. After the Stack Pointer (SP) is reset, it points to the highest address in the internal SRAM. The SP is read/write accessible in the I/O memory space, enabling easy implementation of multiple stacks or stack areas. The data SRAM can easily be accessed through the five different Addressing modes supported by the AVR CPU. See the *Instruction Set Summary* section for details.

6.5.2 Instruction Execution Timing

The AVR CPU is clocked by the CPU clock, CLK_CPU. No internal clock division is applied. The figure below shows the parallel instruction fetches and executions enabled by the Harvard architecture and the fast-access register file concept. This is the basic pipelining concept enabling up to 1 MIPS/MHz performance with high efficiency.

Figure 6-2. The Parallel Instruction Fetches and Executions

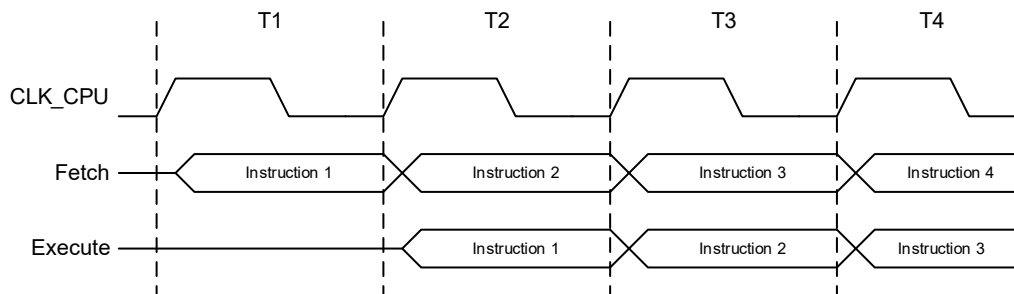

The following figure shows the internal timing concept for the register file. In a single clock cycle, an ALU operation using two register operands is executed, and the result is stored in the destination register.

Figure 6-3. Single Cycle ALU Operation

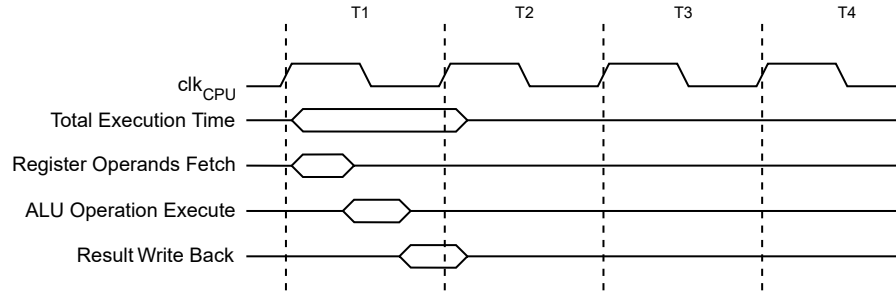

6.5.3 Status Register

The Status Register (CPU.SREG) contains information about the result of the most recently executed arithmetic or logic instructions. This information can be used for altering the program flow to perform conditional operations.

CPU.SREG is updated after all ALU operations, as specified in the *Instruction Set Summary* section, which will, in many cases, remove the need for using the dedicated compare instructions, resulting in a faster and more compact code. CPU.SREG is not automatically stored or restored when entering or returning from an Interrupt Service Routine (ISR). Therefore, maintaining the Status Register between context switches must be handled by user-defined software. CPU.SREG is accessible in the I/O memory space.

6.5.4 Stack and Stack Pointer

The stack is used for storing return addresses after interrupts and subroutine calls. Also, it can be used for storing temporary data. The Stack Pointer (SP) always points to the top of the stack. The address pointed to by the SP is stored in the Stack Pointer (CPU.SP) register. The CPU.SP is implemented as two 8-bit registers that are accessible in the I/O memory space.

Data are pushed and popped from the stack using the instructions given in [Table 6-1](#), or by executing interrupts. The stack grows from higher to lower memory locations. This means that when pushing data onto the stack, the SP decreases, and when popping data off the stack, the SP increases. The SP is automatically set to the highest address of the internal SRAM after being reset. If the stack is changed, it must be set to point above the SRAM start address (see the *SRAM Data Memory* topic in the *Memories* section for the SRAM start address), and it must be defined before any subroutine calls are executed and before interrupts are enabled. See the table below for SP details.

Table 6-1. Stack Pointer Instructions

Instruction	Stack Pointer	Description
PUSH	Decrement by 1	Data are pushed onto the stack
CALL ICALL RCALL	Decrement by 2	A return address is pushed onto the stack with a subroutine call or interrupt
POP	Increment by 1	Data are popped from the stack
RET RETI	Increment by 2	A return address is popped from the stack with a return from subroutine or return from interrupt

During interrupts or subroutine calls, the return address is automatically pushed on the stack as a word, and the SP is decremented by two. The return address consists of two bytes and the Least Significant Byte (LSB) is pushed on the stack first (at the higher address). As an example, a byte pointer return address of 0x0006 is saved on the stack as 0x0003 (shifted one bit to the right), pointing to the fourth 16-bit instruction word in the program memory. The return address is popped off the stack with `RETI` (when returning from interrupts) and `RET` (when returning from subroutine calls), and the SP is incremented by two.

The SP is decremented by one when data are pushed on the stack with the `PUSH` instruction, and incremented by one when data are popped off the stack using the `POP` instruction.

To prevent corruption when updating the SP from software, a write to SPL will automatically disable interrupts for up to four instructions or until the next I/O memory write, whichever comes first.

6.5.5 Register File

The register file consists of 32 8-bit general purpose working registers used by the CPU. The register file is located in a separate address space from the data memory.

All CPU instructions that operate on working registers have direct and single-cycle access to the register file. Some limitations apply to which working registers can be accessed by an instruction, like the constant arithmetic and logic instructions `SBCI`, `SUBI`, `CPI`, `ANDI`, `ORI` and `LDI`. These instructions apply to the second half of the working registers in the register file, R16 to R31. See the *AVR Instruction Set Manual* for further details.

Figure 6-4. AVR® CPU General Purpose Working Registers

7	0	Addr.	
R0	0x00		
R1	0x01		
R2	0x02		
...			
R13	0x0D		
R14	0x0E		
R15	0x0F		
R16	0x10		
R17	0x11		
...			
R26	0x1A	X-register Low Byte	
R27	0x1B	X-register High Byte	
R28	0x1C	Y-register Low Byte	
R29	0x1D	Y-register High Byte	
R30	0x1E	Z-register Low Byte	
R31	0x1F	Z-register High Byte	

6.5.5.1 The X-, Y-, and Z-Registers

Working registers R26...R31 have added functions besides their general purpose usage.

These registers can form 16-bit Address Pointers for indirect addressing of data memory. These three address registers are called the X-register, Y-register, and Z-register. The Z-register can also be used as Address Pointer for program memory.

Figure 6-5. The X-, Y-, and Z-Registers

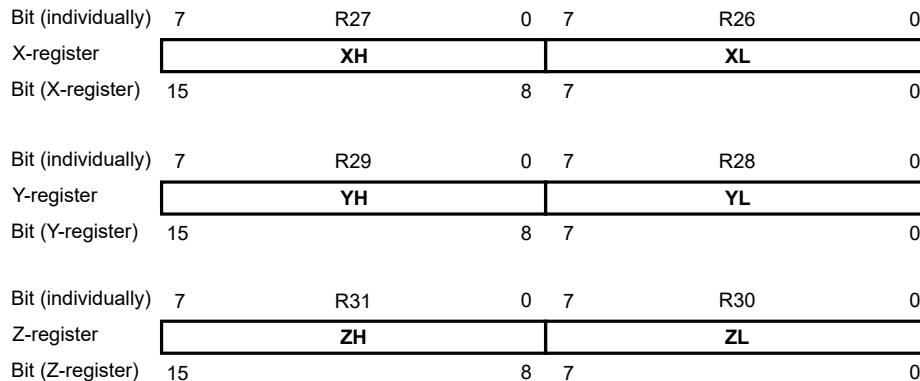

The lowest register address holds the Least Significant Byte (LSB), and the highest register address holds the Most Significant Byte (MSB). These address registers can function as fixed displacement, automatic increment, and automatic decrement, with different `LD*/ST*` instructions. See the *Instruction Set Summary* section for details.

6.5.6 Configuration Change Protection (CCP)

System critical I/O register settings are protected from accidental modification. Flash self-programming is protected from accidental execution. This is handled globally by the Configuration Change Protection (CCP) register.

Changes to the protected I/O registers or bits, or execution of protected instructions, are only possible after the CPU writes a signature to the CCP register. The different signatures are listed in the description of the CCP register (CPU.CCP).

Once the correct signature is written by the CPU, interrupts will be ignored for the duration of the configuration change enable period. Any interrupt request (including non-maskable interrupts) during the CCP period will set the corresponding Interrupt flag as normal, and the request is kept pending. After the CCP period is completed, any pending interrupts are executed according to their level and priority.

There are two modes of operation: One for protected I/O registers, and one for protected self-programming.

6.5.6.1 Sequence for Write Operation to Configuration Change Protected I/O Registers

To write to registers protected by CCP, the following steps are required:

1. The software writes the signature that enables change of protected I/O registers to the CCP bit field in the CPU.CCP register.
2. Within four instructions, the software must write the appropriate data to the protected register. Most protected registers also contain a Write Enable/Change Enable/Lock bit. This bit must be written to '1' in the same operation as the data are written.

The protected change is immediately disabled if the CPU performs write operations to the I/O register or data memory, if load or store accesses to Flash, NVMCTRL, or EEPROM are conducted, or if the `SLEEP` instruction is executed.

6.5.6.2 Sequence for Execution of Self-Programming

To execute self-programming (the execution of writes to the NVM controller's command register), the following steps are required:

1. The software temporarily enables self-programming by writing the SPM signature to the CCP register (CPU.CCP).
2. Within four instructions, the software must execute the appropriate instruction. The protected change is immediately disabled if the CPU performs accesses to the Flash, NVMCTRL, or EEPROM, or if the `SLEEP` instruction is executed.

6.5.7 On-Chip Debug Capabilities

The AVR CPU includes native On-Chip Debug (OCD) support. It contains some powerful debug capabilities to enable profiling and detailed information about the CPU state. It is possible to alter the CPU state and resume code execution. Also, normal debug capabilities like hardware Program Counter breakpoints, breakpoints on change of flow instructions, breakpoints on interrupts, and software breakpoints (`BREAK` instruction) are present. Refer to the *Unified Program and Debug Interface* section for details about OCD.

6.6 Register Summary

Offset	Name	Bit Pos.	7	6	5	4	3	2	1	0
0x00 ...	Reserved									
0x03										
0x04	CCP	7:0	CCP[7:0]							
0x05 ...	Reserved									
0x0C										
0x0D	SP	7:0	SP[7:0]							
		15:8	SP[15:8]							
0x0F	SREG	7:0	I	T	H	S	V	N	Z	C

6.7 Register Description

6.7.1 Configuration Change Protection

Name: CCP
Offset: 0x04
Reset: 0x00
Property: -

Bit	7	6	5	4	3	2	1	0
	CCP[7:0]							
Access	R/W	R/W	R/W	R/W	R/W	R/W	R/W	R/W
Reset	0	0	0	0	0	0	0	0

Bits 7:0 – CCP[7:0] Configuration Change Protection

Writing the correct signature to this bit field allows changing protected I/O registers or executing protected instructions within the next four CPU instructions executed.

All interrupts are ignored during these cycles. After these cycles are completed, the interrupts will automatically be handled by the CPU, and any pending interrupts will be executed according to their level and priority.

When the protected I/O register signature is written, CCP[0] will read '1' as long as the CCP feature is enabled.

When the protected self-programming signature is written, CCP[1] will read '1' as long as the CCP feature is enabled.

CCP[7:2] will always read '0'.

Value	Name	Description
0x9D	SPM	Allow self-programming
0xD8	IOREG	Unlock protected I/O registers

6.7.2 Stack Pointer

Name: SP
Offset: 0x0D
Reset: Top of stack
Property: -

The CPU.SP register holds the Stack Pointer (SP) that points to the top of the stack. After being reset, the SP points to the highest internal SRAM address.

Only the number of bits required to address the available data memory, including external memory (up to 64 KB), is implemented for each device. Unused bits will always read '0'.

The CPU.SPL and CPU.SPH register pair represents the 16-bit value, CPU.SP. The low byte [7:0] (suffix L) is accessible at the original offset. The high byte [15:8] (suffix H) can be accessed at offset + 0x01.

To prevent corruption when updating the SP from software, a write to CPU.SPL will automatically disable interrupts for the next four instructions or until the next I/O memory write, whichever comes first.

Bit	15	14	13	12	11	10	9	8
	SP[15:8]							
Access	R/W	R/W	R/W	R/W	R/W	R/W	R/W	R/W
Reset								
Bit	7	6	5	4	3	2	1	0
	SP[7:0]							
Access	R/W	R/W	R/W	R/W	R/W	R/W	R/W	R/W
Reset								

Bits 15:8 – SP[15:8] Stack Pointer High Byte
 These bits hold the MSB of the 16-bit register.

Bits 7:0 – SP[7:0] Stack Pointer Low Byte
 These bits hold the LSB of the 16-bit register.

6.7.3 Status Register

Name: SREG
Offset: 0x0F
Reset: 0x00
Property: -

The Status Register contains information about the result of the most recently executed arithmetic or logic instructions. For details about the bits in this register and how they are influenced by different instructions, see the *Instruction Set Summary* section.

Bit	7	6	5	4	3	2	1	0
	I	T	H	S	V	N	Z	C
Access	R/W	R/W	R/W	R/W	R/W	R/W	R/W	R/W
Reset	0	0	0	0	0	0	0	0

Bit 7 – I Global Interrupt Enable Bit

Writing a '1' to this bit enables interrupts on the device.

Writing a '0' to this bit disables interrupts on the device, independent of the individual interrupt enable settings of the peripherals.

This bit is not cleared by hardware while entering an Interrupt Service Routine (ISR) or set when the `RETI` instruction is executed.

This bit can be set and cleared by software with the `SEI` and `CLI` instructions.

Changing the I bit through the I/O register results in a one-cycle Wait state on the access.

Bit 6 – T Transfer Bit

The bit copy instructions, Bit Load (`BLD`) and Bit Store (`BST`), use the T bit as source or destination for the operated bit.

Bit 5 – H Half Carry Flag

This flag is set when there is a half carry in arithmetic operations that support this, and is cleared otherwise. Half carry is useful in BCD arithmetic.

Bit 4 – S Sign Flag

This flag is always an Exclusive Or (`XOR`) between the Negative flag (N) and the Two's Complement Overflow (V) flag.

Bit 3 – V Two's Complement Overflow Flag

This flag is set when there is an overflow in arithmetic operations that support this, and is cleared otherwise.

Bit 2 – N Negative Flag

This flag is set when there is a negative result in an arithmetic or logic operation, and is cleared otherwise.

Bit 1 – Z Zero Flag

This flag is set when there is a zero result in an arithmetic or logic operation, and is cleared otherwise.

Bit 0 – C Carry Flag

This flag is set when there is a carry in an arithmetic or logic operation, and is cleared otherwise.

7. Memories

7.1 Overview

The main memories of the ATtiny3224/3226/3227 devices are SRAM data memory space, EEPROM data memory space, and Flash program memory space. Also, the peripheral registers are located in the I/O memory space.

7.2 Memory Map

The figure below shows the memory map for the largest memory derivative in the tinyAVR 2 family. Refer to the subsequent sections and the Peripheral Address Map table for further details.

Figure 7-1. Memory Map: Flash 32 KB, Internal SRAM 3 KB, EEPROM 256B

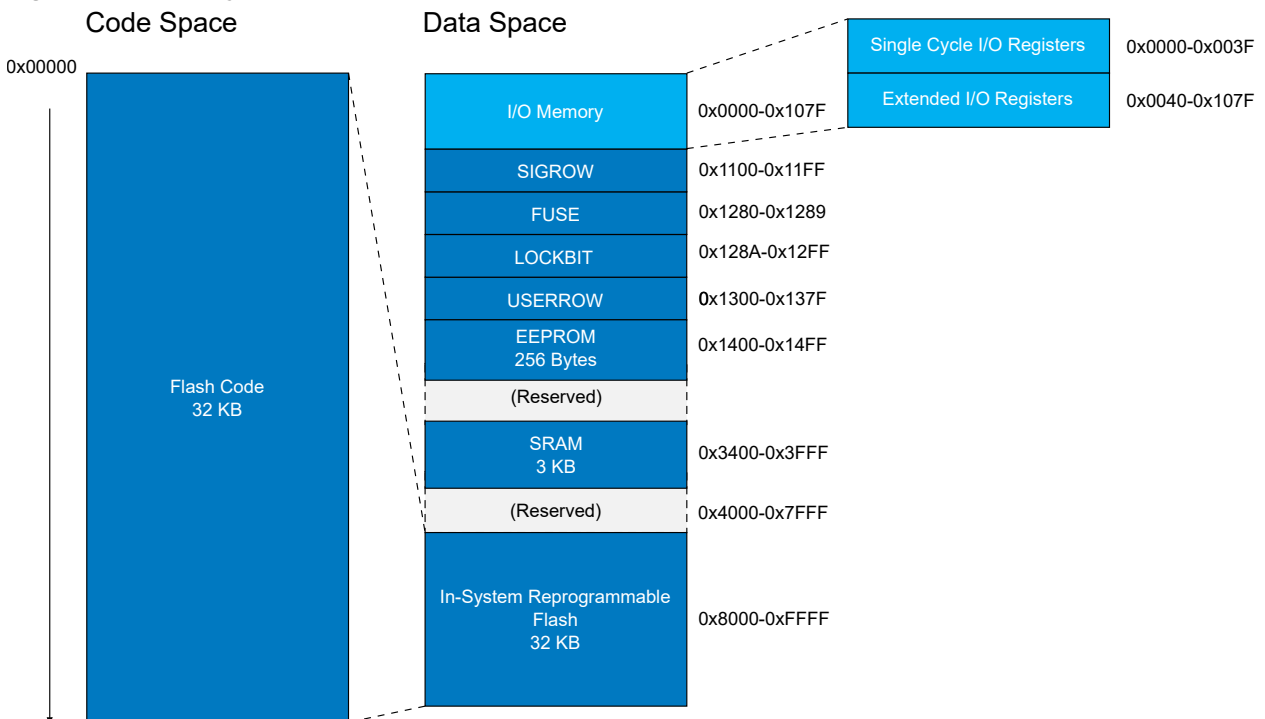

7.3 In-System Reprogrammable Flash Program Memory

The ATtiny3224/3226/3227 contains 32 KB on-chip in-system reprogrammable Flash memory for program storage. Since all AVR instructions are 16 or 32 bits wide, the Flash is organized as 4K x 16-bit pages. For write protection, the Flash program memory space can be divided into three sections (Figure 7-2): Boot section, Application Code section, and Application Data section. Code placed in one section may be restricted from writing to addresses in other sections. See the *Nonvolatile Memory Controller* (NVMCTRL) section for more details.

The Program Counter (PC) can address the whole program memory. The procedure for writing Flash memory is described in detail in the NVMCTRL section.

The Flash memory is mapped into the data space and is accessible with normal LD/ST instructions. For LD/ST instructions, the Flash is mapped from address 0x8000. The Flash memory can be read with the LPM instruction. For the LPM instruction, the Flash start address is 0x0000.

The ATtiny3224/3226/3227 has a CRC module that is a host on the bus.

Table 7-1. Physical Properties of Flash Memory

Property	ATtiny322x
Size	32 KB
Page size	128B
Number of pages	256
Start address in data space	0x8000
Start address in code space	0x0

Figure 7-2. Flash Areas

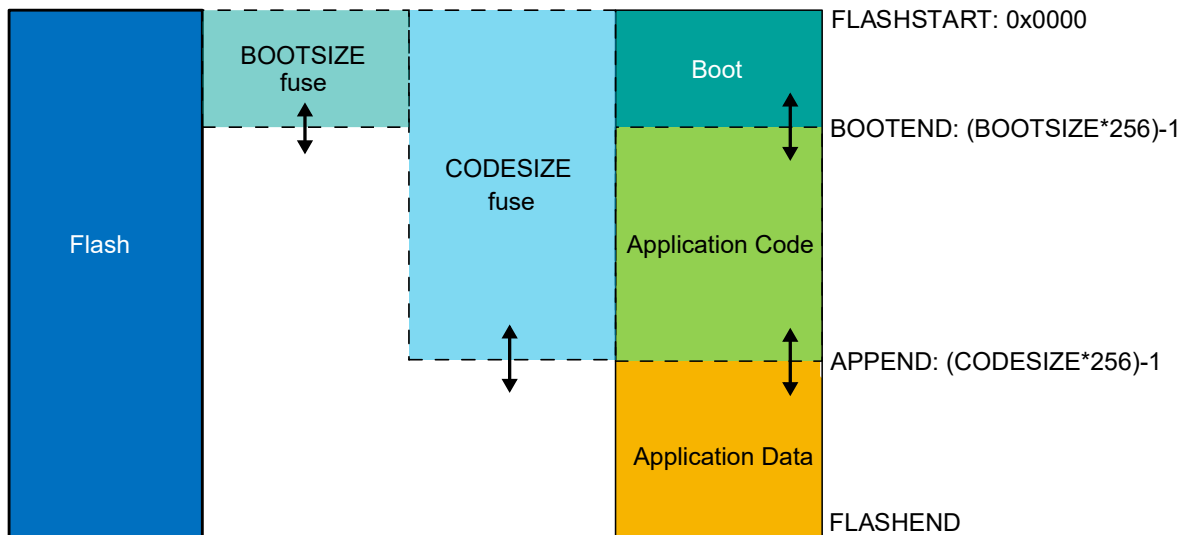

7.4 SRAM Data Memory

The primary task of the SRAM memory is to store application data. Also, the program stack is located at the end of SRAM.

It is not possible to execute code from SRAM.

Table 7-2. Physical Properties of SRAM

Property	ATtiny322x
Size	3 KB
Start address	0x3400

7.5 EEPROM Data Memory

The primary task of the EEPROM memory is to store nonvolatile application data. The EEPROM memory supports single- and multi-byte read and write. The EEPROM is controlled by the Nonvolatile Memory Controller (NVMCTRL).

Table 7-3. Physical Properties of EEPROM

Property	ATtiny322x
Size	256B
Page size	64B

.....continued	
Property	ATtiny322x
Number of pages	4
Start address	0x1400

7.6 USERROW - User Row

The ATtiny3224/3226/3227 has one extra page of EEPROM memory that can be used for firmware settings, the User Row (USERROW). This memory supports single-byte read and write as the normal EEPROM. The CPU can write and read this memory as normal EEPROM, and the UPDI can write and read it as a normal EEPROM memory if the part is unlocked. The User Row can be written by the UPDI when the part is locked. USERROW is not affected by a chip erase.

7.7 LOCKBIT - Memory Sections Access Protection

The device can be locked so that the memories cannot be read using the UPDI. The locking protects both the Flash (all Boot, Application Code, and Application Date sections), SRAM, and the EEPROM, including the FUSE data. This prevents successful reading of application data or code using the debugger interface. Regular memory access from within the application is still enabled.

The device is locked by writing a non-valid key to the LOCKBIT bit field in FUSE.LOCKBIT.

Table 7-4. Memory Access Unlocked (FUSE.LOCKBIT Valid Key)⁽¹⁾

Memory Section	CPU Access		UPDI Access	
	Read	Write	Read	Write
SRAM	Yes	Yes	Yes	Yes
Registers	Yes	Yes	Yes	Yes
Flash	Yes	Yes	Yes	Yes
EEPROM	Yes	Yes	Yes	Yes
USERROW	Yes	Yes	Yes	Yes
SIGROW	Yes	No	Yes	No
Other fuses including LOCK	Yes	No	Yes	Yes

Table 7-5. Memory Access Locked (FUSE.LOCKBIT Invalid Key)⁽¹⁾

Memory Section	CPU Access		UPDI Access	
	Read	Write	Read	Write
SRAM	Yes	Yes	No	No
Registers	Yes	Yes	No	No
Flash	Yes	Yes	No	No
EEPROM	Yes	Yes	No	No
USERROW	Yes	Yes	No	Yes ⁽²⁾
SIGROW	Yes	No	No	No

.....continued

Memory Section	CPU Access		UPDI Access	
	Read	Write	Read	Write
Other fuses including LOCK	Yes	No	No	No

Notes:

1. Read operations marked No in the tables may appear to be successful, but the data is not valid. Hence, any attempt of code validation through the UPDI will fail on these memory sections.
2. In the Locked mode, the USERROW can be written using the Fuse Write command, but the current USERROW values cannot be read out.



Important: The only way to unlock a device is CHIPERASE. No application data is retained.

7.7.1 Lock Bit Summary

Offset	Name	Bit Pos.	7	6	5	4	3	2	1	0
0x00	LOCKBIT	7:0	LOCKBIT[7:0]							

7.7.2 Lock Bit Description

7.7.2.1 Lock Bits

Name: LOCKBIT
Offset: 0x00
Default: 0xC5
Property: -

The default value given in this fuse description is the factory-programmed value, and should not be mistaken for the Reset value.

Bit	7	6	5	4	3	2	1	0
	LOCKBIT[7:0]							
Access	R/W	R/W	R/W	R/W	R/W	R/W	R/W	R/W
Default	1	1	0	0	0	1	0	1

Bits 7:0 – LOCKBIT[7:0] Lock Bits

When the part is locked, UPDI cannot access the system bus, so it cannot read out anything but CS-space.

Value	Description
0xC5	Valid key - the device is open
other	Invalid - the device is locked

7.8 FUSE - Configuration and User Fuses

Fuses are part of the nonvolatile memory and hold the device configuration. The fuses can be read by the CPU or the UPDI, but can only be programmed or cleared by the UPDI. The configuration values stored in the fuses are written to their respective target registers at the end of the start-up sequence.

The fuses for peripheral configuration (FUSE) are pre-programmed but can be altered by the user. Altered values in the configuration fuse will be effective only after a Reset.

Note: When writing the fuses, all reserved bits must be written to '1'.

7.8.1 Fuse Summary

Offset	Name	Bit Pos.	7	6	5	4	3	2	1	0
0x00	WDTCFG	7:0	WINDOW[3:0]				PERIOD[3:0]			
0x01	BODCFG	7:0	LVL[2:0]		SAMPFREQ	ACTIVE[1:0]		SLEEP[1:0]		
0x02	OSCCFG	7:0	OSCCLOCK						FREQSEL[1:0]	
0x03	Reserved									
0x04										
0x05	SYSCFG0	7:0	CRCSRC[1:0]			TOUTDIS	RSTPINCFG[1:0]			EESAVE
0x06	SYSCFG1	7:0						SUT[2:0]		
0x07	APPEND	7:0	APPEND[7:0]							
0x08	BOOTEND	7:0	BOOTEND[7:0]							

7.8.2 Fuse Description

7.8.2.1 Watchdog Configuration

Name: WDTCFG
Offset: 0x00
Default: 0x00
Property: -

The default value given in this fuse description is the factory-programmed value, and should not be mistaken for the Reset value.

Bit	7	6	5	4	3	2	1	0
	WINDOW[3:0]				PERIOD[3:0]			
Access	R	R	R	R	R	R	R	R
Default	0	0	0	0	0	0	0	0

Bits 7:4 – WINDOW[3:0] Watchdog Window Time-out Period

This value is loaded into the WINDOW bit field of the Watchdog Control A (WDT.CTRLA) register during reset.

Bits 3:0 – PERIOD[3:0] Watchdog Time-out Period

This value is loaded into the PERIOD bit field of the Watchdog Control A (WDT.CTRLA) register during reset.

7.8.2.2 BOD Configuration

Name: BODCFG
Offset: 0x01
Default: 0x00
Property: -

The settings of the BOD will be loaded from this Fuse after a Reset.

The default value given in this fuse description is the factory-programmed value, and should not be mistaken for the Reset value.

Bit	7	6	5	4	3	2	1	0
	LVL[2:0]			SAMPFREQ	ACTIVE[1:0]		SLEEP[1:0]	
Access	R	R	R	R	R	R	R	R
Default	0	0	0	0	0	0	0	0

Bits 7:5 – LVL[2:0] BOD Level

This value is loaded into the LVL bit field of the BOD Control B (BOD.CTRLB) register during Reset.

Value	Name	Description
0x0	BODLEVEL0	1.8V
0x1	BODLEVEL1	2.15V
0x2	BODLEVEL2	2.60V
0x3	BODLEVEL3	2.95V
0x4	BODLEVEL4	3.30V
0x5	BODLEVEL5	3.70V
0x6	BODLEVEL6	4.00V
0x7	BODLEVEL7	4.30V

Bit 4 – SAMPFREQ BOD Sample Frequency

This value is loaded into the SAMPFREQ bit of the BOD Control A (BOD.CTRLA) register during Reset.

Value	Description
0x0	The sample frequency is 1 kHz
0x1	The sample frequency is 125 Hz

Bits 3:2 – ACTIVE[1:0] BOD Operation Mode in Active and Idle

This value is loaded into the ACTIVE bit field of the BOD Control A (BOD.CTRLA) register during Reset.

Value	Description
0x0	Disabled
0x1	Enabled
0x2	Sampled
0x3	Enabled with wake-up halted until BOD is ready

Bits 1:0 – SLEEP[1:0] BOD Operation Mode in Sleep

This value is loaded into the SLEEP bit field of the BOD Control A (BOD.CTRLA) register during Reset.

Value	Description
0x0	Disabled
0x1	Enabled
0x2	Sampled
0x3	Reserved

7.8.2.3 Oscillator Configuration

Name: OSCCFG
Offset: 0x02
Default: 0x7E
Property: -

The default value given in this fuse description is the factory-programmed value, and should not be mistaken for the Reset value.

Bit	7	6	5	4	3	2	1	0
	OSCLOCK						FREQSEL[1:0]	
Access	R						R	R
Default	0						1	0

Bit 7 – OSCLOCK Oscillator Lock

This fuse bit is loaded to LOCK in CLKCTRL.OSC20MCALIBB during reset.

Value	Description
0	Calibration registers of the 20 MHz oscillator are accessible
1	Calibration registers of the 20 MHz oscillator are locked

Bits 1:0 – FREQSEL[1:0] Frequency Select

These bits select the operation frequency of the 20 MHz internal oscillator (OSC20M) and determine the respective factory calibration values to be written to CAL20M in CLKCTRL.OSC20MCALIBA and TEMPCAL20M in CLKCTRL.OSC20MCALIBB.

Value	Description
0x0	Reserved
0x1	Run at 16 MHz
0x2	Run at 20 MHz
0x3	Reserved

7.8.2.4 System Configuration 0

Name: SYSCFG0
Offset: 0x05
Default: 0xF6
Property: -

The default value given in this fuse description is the factory-programmed value, and should not be mistaken for the Reset value.

Bit	7	6	5	4	3	2	1	0
	CRCSRC[1:0]			TOUTDIS	RSTPINCFG[1:0]			EESAVE
Access	R	R		R	R	R		R
Default	1	1		1	0	1		0

Bits 7:6 – CRCSRC[1:0] CRC Source

See the CRC description for more information about the functionality.

Value	Name	Description
0x0	FLASH	CRC of full Flash (boot, application code and application data)
0x1	BOOT	CRC of the boot section
0x2	BOOTAPP	CRC of application code and boot sections
0x3	NOCRC	No CRC

Bit 4 – TOUTDIS Time-Out Disable

This bit can disable the blocking of NVM writes after POR.

When the TOUTDIS bit in FUSE.SYSCFG0 is '0' and the RSTPINCFG bit field in FUSE.SYSCFG0 is configured to GPIO or RESET, there will be a time-out period after POR that blocks NVM writes.

The NVM write block will last for 768 OSC32K cycles after POR. The EEBUSY and FBUSY bits in the NVMCTRL.STATUS register must read '0' before the page buffer can be filled or NVM commands can be issued.

Value	Description
0	NVM write block is enabled
1	NVM write block is disabled

Bits 3:2 – RSTPINCFG[1:0] Reset Pin Configuration

This bit selects the pin configuration for the Reset pin.

Note: When configuring the Reset pin as GPIO, there is a potential conflict between the GPIO actively driving the output, and a high-voltage UPDI enable sequence initiation. To avoid this, the GPIO output driver is disabled for 768 OSC32K cycles after a System Reset. Enable any interrupts for this pin only after this period.

Value	Description
0x0	GPIO
0x1	UPDI
0x2	RESET
0x3	UPDI w/alternate RESET pin

Bit 0 – EESAVE EEPROM Save Across Chip Erase

This bit controls if the EEPROM is being erased during a Chip Erase. If enabled, only the Flash memory will be erased by the Chip Erase. If the device is locked, the EEPROM is always erased by a Chip Erase regardless of this bit.

Value	Description
0	EEPROM erased during Chip Erase
1	EEPROM not erased under Chip Erase

7.8.2.5 System Configuration 1

Name: SYSCFG1
Offset: 0x06
Default: 0xFF
Property: -

The default value given in this fuse description is the factory-programmed value, and should not be mistaken for the Reset value.

Bit	7	6	5	4	3	2	1	0
						SUT[2:0]		
Access						R	R	R
Default						1	1	1

Bits 2:0 – SUT[2:0] Start-up Time Setting

These bits select the start-up time between power-on and code execution.

Value	Description
0x0	0 ms
0x1	1 ms
0x2	2 ms
0x3	4 ms
0x4	8 ms
0x5	16 ms
0x6	32 ms
0x7	64 ms

7.8.2.6 Application Code End

Name: APPEND
Offset: 0x07
Default: 0x00
Property: -

The default value given in this fuse description is the factory-programmed value, and should not be mistaken for the Reset value.

Bit	7	6	5	4	3	2	1	0
	APPEND[7:0]							
Access	R	R	R	R	R	R	R	R
Default	0	0	0	0	0	0	0	0

Bits 7:0 – APPEND[7:0] Application Code Section End

This bit field controls the combined size of the Boot Code section and Application Code section in blocks of 256 bytes. For more details, refer to the Nonvolatile Memory Controller section.

Note: If FUSE.BOOTEND is 0x00, the entire Flash is the Boot Code section.

7.8.2.7 Boot End

Name: BOOTEND
Offset: 0x08
Default: 0x00
Property: -

The default value given in this fuse description is the factory-programmed value, and should not be mistaken for the Reset value.

Bit	7	6	5	4	3	2	1	0
	BOOTEND[7:0]							
Access	R	R	R	R	R	R	R	R
Default	0	0	0	0	0	0	0	0

Bits 7:0 – BOOTEND[7:0] Boot Section End

This bit field controls the size of the boot section in blocks of 256 bytes. A value of 0x00 defines the entire Flash as Boot Code section.

For more details, refer to the *Nonvolatile Memory Controller* section.

7.9 SIGROW - Signature Row

The content of the Signature Row (SIGROW) fuses is pre-programmed and cannot be altered. SIGROW holds information such as device ID, serial number, and calibration values.

All AVR microcontrollers have a three-byte device ID that identifies the device. This device ID can be read using the UPDI interface, also when the device is locked. The three bytes reside in the Signature Row. The signature bytes are given in the following table.

Table 7-6. Device ID

Device Name	Signature Bytes Address		
	0x00	0x01	0x02
ATtiny3227	0x1E	0x95	0x26
ATtiny3226	0x1E	0x95	0x27
ATtiny3224	0x1E	0x95	0x28

7.9.1 Signature Row Summary

Offset	Name	Bit Pos.	7	6	5	4	3	2	1	0
0x00	DEVICEID0	7:0								DEVICEID[7:0]
0x01	DEVICEID1	7:0								DEVICEID[7:0]
0x02	DEVICEID2	7:0								DEVICEID[7:0]
0x03	SERNUM0	7:0								SERNUM[7:0]
0x04	SERNUM1	7:0								SERNUM[7:0]
0x05	SERNUM2	7:0								SERNUM[7:0]
0x06	SERNUM3	7:0								SERNUM[7:0]
0x07	SERNUM4	7:0								SERNUM[7:0]
0x08	SERNUM5	7:0								SERNUM[7:0]
0x09	SERNUM6	7:0								SERNUM[7:0]
0x0A	SERNUM7	7:0								SERNUM[7:0]
0x0B	SERNUM8	7:0								SERNUM[7:0]
0x0C	SERNUM9	7:0								SERNUM[7:0]
0x0D ... 0x17	Reserved									
0x18	OSCCAL16M0	7:0								OSCCAL16M[6:0]
0x19	OSCCAL16M1	7:0								OSCCAL16MTCAL[3:0]
0x1A	OSCCAL20M0	7:0								OSCCAL20M[6:0]
0x1B	OSCCAL20M1	7:0								OSCCAL20MTCAL[3:0]
0x1C ... 0x1F	Reserved									
0x20	TEMPSENSE0	7:0								TEMPSENSE[7:0]
0x21	TEMPSENSE1	7:0								TEMPSENSE[7:0]

7.9.2 Signature Row Description

7.9.2.1 Device ID n

Name: DEVICEIDn
Offset: 0x00 + n*0x01 [n=0..2]
Reset: [Device ID]
Property: -

Each device has a device ID identifying the device and its properties such as memory sizes, pin count, and die revision. This can be used to identify a device and hence, the available features by software. The Device ID consists of three bytes: SIGROW.DEVICEID[2:0].

Bit	7	6	5	4	3	2	1	0
	DEVICEID[7:0]							
Access	R	R	R	R	R	R	R	R
Reset	x	x	x	x	x	x	x	x

Bits 7:0 – DEVICEID[7:0] Byte n of the Device ID

7.9.2.2 Serial Number Byte n

Name: SERNUMn
Offset: 0x03 + n*0x01 [n=0..9]
Reset: [Byte n of device serial number]
Property: -

Each device has an individual serial number representing a unique ID. This can be used to identify a specific device in the field. The serial number consists of ten bytes: SIGROW.SERNUM[9:0].

Bit	7	6	5	4	3	2	1	0
	SERNUM[7:0]							
Access	R	R	R	R	R	R	R	R
Reset	x	x	x	x	x	x	x	x

Bits 7:0 – SERNUM[7:0] Serial Number Byte n

7.9.2.3 OSC16 Calibration Byte

Name: OSCCAL16M0
Offset: 0x18
Reset: [Factory oscillator calibration value]
Property: -

Bit	7	6	5	4	3	2	1	0
	OSCCAL16M[6:0]							
Access		R	R	R	R	R	R	R
Reset		x	x	x	x	x	x	x

Bits 6:0 – OSCCAL16M[6:0] OSC16 Calibration

These bits contains factory calibration values for the internal 16 MHz oscillator. If the OSCCFG fuse is configured to run the device at 16 MHz, this byte is automatically copied to the OSC20MCALIBA register during Reset to calibrate the internal 16 MHz RC Oscillator.

7.9.2.4 OSC16 Temperature Calibration Byte

Name: OSCCAL16M1
Offset: 0x19
Reset: [Factory oscillator temperature calibration value]
Property: -

Bit	7	6	5	4	3	2	1	0
					OSCCAL16MTCAL[3:0]			
Access					R	R	R	R
Reset					x	x	x	x

Bits 3:0 – OSCCAL16MTCAL[3:0] OSC16 Temperature Calibration

These bits contain factory temperature calibration values for the internal 16 MHz oscillator. If the OSCCFG fuse is configured to run the device at 16 MHz, this byte is automatically written into the OSC20MCALIBB register during Reset to ensure correct frequency of the calibrated RC Oscillator.

7.9.2.5 OSC20 Calibration Byte

Name: OSCCAL20M0
Offset: 0x1A
Reset: [Factory oscillator calibration value]
Property: -

Bit	7	6	5	4	3	2	1	0
	OSCCAL20M[6:0]							
Access		R	R	R	R	R	R	R
Reset		x	x	x	x	x	x	x

Bits 6:0 – OSCCAL20M[6:0] OSC20 Calibration

These bits contain factory calibration values for the internal 20 MHz oscillator. If the OSCCFG fuse is configured to run the device at 20 MHz, this byte is automatically written into the OSC20MCALIBA register during Reset to ensure correct frequency of the calibrated RC Oscillator.

7.9.2.6 OSC20 Temperature Calibration Byte

Name: OSCCAL20M1
Offset: 0x1B
Reset: [Factory oscillator temperature calibration value]
Property: -

Bit	7	6	5	4	3	2	1	0
					OSCCAL20MTCAL[3:0]			
Access					R	R	R	R
Reset					x	x	x	x

Bits 3:0 – OSCCAL20MTCAL[3:0] OSC20 Temperature Calibration

These bits contain factory temperature calibration values for the internal 20 MHz oscillator. If the OSCCFG fuse is configured to run the device at 20 MHz, this byte is automatically written into the OSC20MCALIBB register during Reset to ensure correct frequency of the calibrated RC Oscillator.

7.9.2.7 Temperature Sensor Calibration n

Name: TEMPSENSEn
Offset: 0x20 + n*0x01 [n=0..1]
Reset: [Temperature sensor calibration value]
Property: -

The Temperature Sensor Calibration registers contain correction factors for temperature measurements from the on-chip sensor. SIGROW.TEMPSENSE0 is a correction factor for the gain/slope (unsigned) and SIGROW.TEMPSENSE1 is a correction factor for the offset (signed).

Bit	7	6	5	4	3	2	1	0
	TEMPSENSE[7:0]							
Access	R	R	R	R	R	R	R	R
Reset	x	x	x	x	x	x	x	x

Bits 7:0 – TEMPSENSE[7:0] Temperature Sensor Calibration Byte n

Refer to the *ADC - Analog-to-Digital Converter* section for a description of how to use this register.

7.10 I/O Memory

All ATtiny3224/3226/3227 devices' I/O and peripheral registers are located in the I/O memory space. Refer to the *Peripheral Address Map* table for further details.

For compatibility with a future device, if a register containing reserved bits is written, the reserved bits should be written to '0'. Reserved I/O memory addresses should never be written.

Single-Cycle I/O Registers

The I/O memory ranging from 0x00 to 0x3F can be accessed by a single-cycle CPU instruction using the IN or OUT instructions.

The peripherals available in the single-cycle I/O registers are as follows:

- VPORTx
 - Refer to the *I/O Configuration* section for further details
- GPIO
 - Refer to the *I/O Configuration* section for further details
- CPU
 - Refer to the *AVR CPU* section for further details

The single-cycle I/O registers ranging from 0x00 to 0x1F (VPORTx and GPIO) are also directly bit-accessible using the SBI or CBI instruction. In these single-cycle I/O registers, single bits can be checked by using the SBIS or SBIC instruction.

Refer to the Instruction Set Summary for further details.

7.10.1 Accessing 16-Bit Registers

Most of the registers for the ATtiny3224/3226/3227 devices are 8-bit registers, but the devices also feature a few 16-bit registers. As the AVR data bus has a width of eight bits, accessing the 16-bit requires two read or write operations. All the 16-bit registers of the ATtiny3224/3226/3227 devices are connected to the 8-bit bus through a temporary (TEMP) register.

Figure 7-3. 16-Bit Register Write Operation

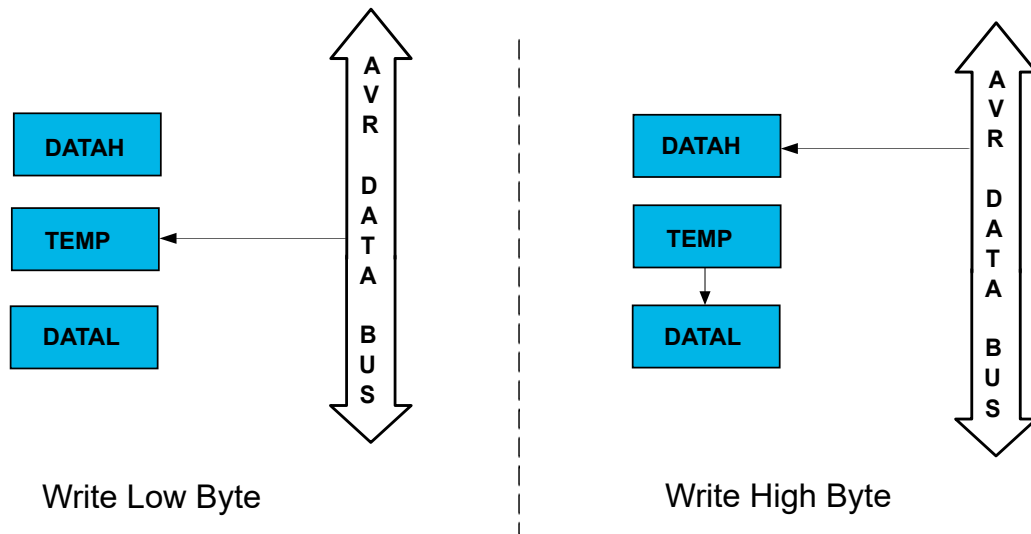

For a 16-bit write operation, the low byte register (e.g., DATAL) of the 16-bit register must be written before the high byte register (e.g., DATAH). Writing the low byte register will result in a write to the temporary (TEMP) register instead of the low byte register, as shown in the left side of the figure above. When the high byte register of the 16-bit register is written, TEMP will be copied into the low byte of the 16-bit register in the same clock cycle, as shown on the right side of the same figure.

Figure 7-4. 16-Bit Register Read Operation

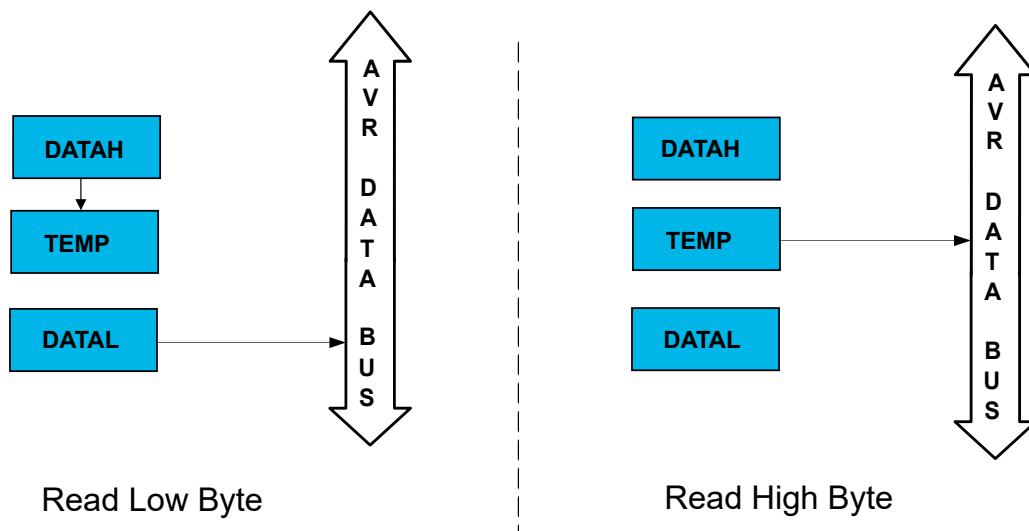

For a 16-bit read operation, the low byte register (e.g., DATAL) of the 16-bit register must be read before the high byte register (e.g., DATAH). When the low byte register is read, the high byte register of the 16-bit register is copied

into the temporary (TEMP) register in the same clock cycle, as shown on the left side of the figure above. Reading the high byte register will result in a read from TEMP instead of the high byte register, as shown on the right side of the same figure.

The described mechanism ensures that the low and high bytes of 16-bit registers are always accessed simultaneously when reading or writing the registers.

Interrupts can corrupt the timed sequence if an interrupt is triggered during a 16-bit read/write operation, and a 16-bit register within the same peripheral is accessed in the interrupt service routine. To prevent this, interrupts should be disabled when writing or reading 16-bit registers. Alternatively, the temporary register can be read before and restored after the 16-bit access in the interrupt service routine.

7.10.2 Accessing 32-Bit Registers

For 32-bit registers, the read and write access is done in the same way as described for 16-bit registers, except there are three temporary registers for 32-bit registers. The Most Significant Byte (MSB) must be written last when writing to the register, and the Least Significant Byte (LSB) must be read first when reading the register.

8. Peripherals and Architecture

8.1 Peripheral Address Map

The address map shows the base address for each peripheral. For complete register description and summary for each peripheral, refer to the respective peripheral sections.

Table 8-1. Peripheral Address Map

Base Address	Name	Description
0x0000	VPORTA	Virtual Port A
0x0004	VPORTB	Virtual Port B
0x0008	VPORTC	Virtual Port C
0x001C	GPIO	General Purpose I/O registers
0x0030	CPU	CPU
0x0040	RSTCTRL	Reset Controller
0x0050	SLPCTRL	Sleep Controller
0x0060	CLKCTRL	Clock Controller
0x0080	BOD	Brown-out Detector
0x00A0	VREF	Voltage Reference
0x0100	WDT	Watchdog Timer
0x0110	CPUINT	Interrupt Controller
0x0120	CRCSCAN	Cyclic Redundancy Check Memory Scan
0x0140	RTC	Real-Time Counter
0x0180	EVSYS	Event System
0x01C0	CCL	Configurable Custom Logic
0x0400	PORTA	Port A Configuration
0x0420	PORTB	Port B Configuration
0x0440	PORTC	Port C Configuration
0x05E0	PORTMUX	Port Multiplexer
0x0600	ADC0	Analog-to-Digital Converter
0x0680	AC0	Analog Comparator 0
0x0800	USART0	Universal Synchronous Asynchronous Receiver Transmitter 0
0x0820	USART1	Universal Synchronous Asynchronous Receiver Transmitter 1
0x08A0	TWI0	Two-Wire Interface
0x08C0	SPI0	Serial Peripheral Interface
0x0A00	TCA0	Timer/Counter Type A instance 0
0x0A80	TCB0	Timer/Counter Type B instance 0
0x0A90	TCB1	Timer/Counter Type B instance 1

.....continued

Base Address	Name	Description
0x0F00	SYSCFG	System Configuration
0x1000	NVMCTRL	Nonvolatile Memory Controller

Table 8-2. System Memory Address Map

Base Address	Name	Description
0x1100	SIGROW	Signature Row
0x1280	FUSE	Device specific fuses
0x128A	LOCKBIT	Lock bits
0x1300	USERROW	User Row

8.2 Interrupt Vector Mapping

Each of the interrupt vectors is connected to one peripheral instance, as shown in the table below. A peripheral can have one or more interrupt sources. For more details on the available interrupt sources, see the 'Interrupt' section in the 'Functional Description' of the respective peripheral.

An Interrupt Flag is set in the Interrupt Flags register of the peripheral (`peripheral.INTFLAGS`) when the interrupt condition occurs, even if the interrupt is not enabled.

An interrupt is enabled or disabled by writing to the corresponding Interrupt Enable bit in the peripheral's Interrupt Control (`peripheral.INTCTRL`) register.

An interrupt request is generated when the corresponding interrupt is enabled, and the Interrupt Flag is set. The interrupt request remains active until the Interrupt Flag is cleared. See the peripheral's `INTFLAGS` register for details on how to clear Interrupt Flags.

Note: Interrupts must be enabled globally for interrupt requests to be generated.

Table 8-3. Interrupt Vector Mapping

Vector Number	Program Address (Word)	Peripheral Source (Name)	Description
0	0x00		RESET
1	0x02	NMI	Non-Maskable Interrupt available for CRCSCAN
2	0x04	BOD_VLM	Voltage Level Monitor interrupt
3	0x06	RTC_CNT	Real Time Counter Overflow or compare match interrupt
4	0x08	RTC_PIT	Real Time Counter Periodic Interrupt
5	0x0A	CCL_CCL	Configurable Custom Logic interrupt
6	0x0C	PORTA_PORT	PORT A External interrupt
7	0x0E	PORT_PORTB	PORT B External interrupt
8	0x10	TCA0_OVF TCA_LUNF	Normal: Timer/Counter Type A Overflow interrupt Split: Timer/Counter Type A Low Underflow interrupt
9	0x12	TCA0_HUNF	Normal: Unused Split: Timer/Counter Type A High Underflow interrupt

.....continued

Vector Number	Program Address (Word)	Peripheral Source (Name)	Description
10	0x14	TCA0_CMP0 TCA0_LCMP0	Normal: Timer/Counter Type A Compare channel 0 interrupt Split: Timer/Counter Type A Low Compare channel 0 interrupt
11	0x16	TCA0_CMP1 TCA0_LCMP1	Normal: Timer/Counter Type A Compare channel 1 interrupt Split: Timer/Counter Type A Low Compare channel 1 interrupt
12	0x18	TCA0_CMP2 TCA0_LCMP2	Normal: Timer/Counter Type A Compare channel 2 interrupt Split: Timer/Counter Type A Low Compare channel 2 interrupt
13	0x1A	TCB0_INT	Timer/Counter Type B Capture interrupt
14	0x1C	TWIO_TWIS	Two Wire Interface Client interrupt
15	0x1E	TWIO_TWIM	Two Wire Interface Host interrupt
16	0x20	SPI0_INT	Serial Peripheral Interface 0 interrupt
17	0x22	USART0_RCX	Universal Synchronous and Asynchronous Receiver and Transmitter 0 Receive Complete interrupt
18	0x24	USART0_DRE	Universal Synchronous and Asynchronous Receiver and Transmitter 0 Data Register Empty interrupt
19	0x26	USART0_TXC	Universal Synchronous and Asynchronous Receiver and Transmitter 0 Transmit Complete interrupt
20	0x28	AC0_AC	Analog Comparator Compare interrupt
21	0x2A	ADC0_ERROR	Analog-to-Digital Converter Error interrupt
22	0x2C	ADC0_RESRDY	Analog-to-Digital Converter Result interrupt
23	0x2E	ADC0_SAMPDY	Analog-to-Digital Converter Sample interrupt
24	0x30	PORTC_PORT	PORT C External interrupt
25	0x32	TCB1_INT	Timer/Counter Type B Capture interrupt
26	0x34	USART1_RCX	Universal Synchronous and Asynchronous Receiver and Transmitter 1 Receive Complete interrupt
27	0x36	USART1_DRE	Universal Synchronous and Asynchronous Receiver and Transmitter 1 Data Register Empty interrupt
28	0x38	USART1_TXC	Universal Synchronous and Asynchronous Receiver and Transmitter 1 Transmit Complete interrupt
29	0x3A	NVMCTRL_EE	Non-Volatile Memory Controller Ready interrupt

8.3 SYSCFG - System Configuration

The system configuration contains the revision ID of the part. The revision ID is readable from the CPU, making it useful for implementing application changes between part revisions.

8.3.1 Register Summary

Offset	Name	Bit Pos.	7	6	5	4	3	2	1	0
0x00	Reserved									
0x01	REVID	7:0	REVID[7:0]							

8.3.2 Register Description

8.3.2.1 Device Revision ID Register

Name: REVID
Offset: 0x01
Reset: [revision ID]
Property: -

This register is read-only and displays the device revision ID.

Bit	7	6	5	4	3	2	1	0
	REVID[7:0]							
Access	R	R	R	R	R	R	R	R
Reset								

Bits 7:0 – REVID[7:0] Revision ID

This bit field contains the device revision. 0x00 = A, 0x01 = B, and so on.

9. General Purpose I/O Registers

The ATtiny3224/3226/3227 devices provide four general purpose I/O registers. These registers can be used for storing any information, and they are particularly useful for storing global variables and interrupt flags. General purpose I/O registers, which reside in the address range $0x1C-0x1F$, are directly bit-accessible using the `SBI`, `CBI`, `SBIS`, and `SBIC` instructions.

9.1 Register Summary

Offset	Name	Bit Pos.	7	6	5	4	3	2	1	0	
0x00	GPIOR0	7:0	GPIOR[7:0]								
0x01	GPIOR1	7:0	GPIOR[7:0]								
0x02	GPIOR2	7:0	GPIOR[7:0]								
0x03	GPIOR3	7:0	GPIOR[7:0]								

9.2 Register Description

9.2.1 General Purpose I/O Register n

Name: GPIORn
Offset: 0x00 + n*0x01 [n=0..3]
Reset: 0x00
Property: -

These are general purpose registers that can be used to store data, such as global variables and flags, in the bit accessible I/O memory space.

Bit	7	6	5	4	3	2	1	0
	GPIOR[7:0]							
Access	R/W	R/W	R/W	R/W	R/W	R/W	R/W	R/W
Reset	0	0	0	0	0	0	0	0

Bits 7:0 – GPIOR[7:0] General Purpose I/O Register Byte

10. NVMCTRL - Nonvolatile Memory Controller

10.1 Features

- Unified Memory
- In-System Programmable
- Self-Programming and Boot Loader Support
- Configurable Sections for Write Protection:
 - Boot section for boot loader code or application code
 - Application code section for application code
 - Application data section for application code or data storage
- Signature Row for Factory-Programmed Data:
 - ID for each device type
 - Serial number for each device
 - Calibration bytes for factory-calibrated peripherals
- User Row for Application Data:
 - Can be read and written from software
 - Can be written from UPDI on a locked device
 - Content is kept after chip erase

10.2 Overview

The NVM Controller (NVMCTRL) is the interface between the CPU and Nonvolatile Memories (Flash, EEPROM, Signature Row, User Row, and fuses). These are reprogrammable memory blocks that retain their values when they are not powered. The Flash is mainly used for program storage and can also be used for data storage, while the EEPROM, Signature Row, User Row, and fuses are used for data storage.

10.2.1 Block Diagram

Figure 10-1. NVMCTRL Block Diagram

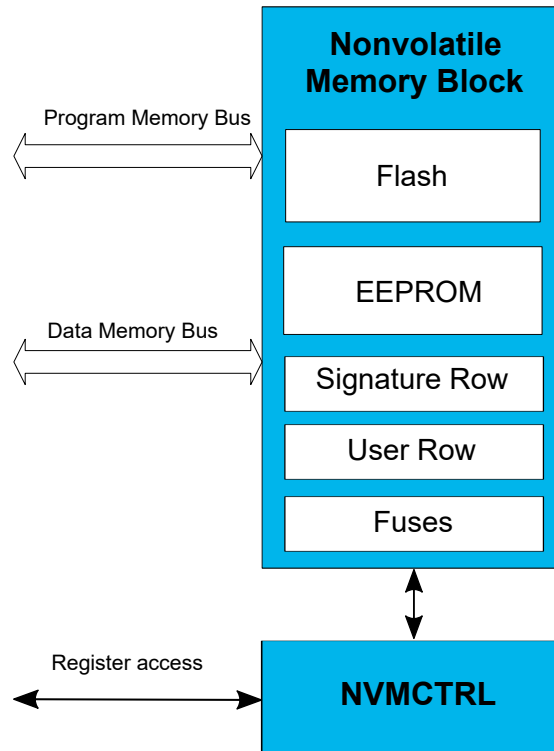

10.3 Functional Description

10.3.1 Memory Organization

10.3.1.1 Flash

The Flash is divided into a set of pages. A page is the basic unit addressed when programming the Flash. It is only possible to write or erase a whole page at a time. One page consists of several words.

The Flash can be divided into three sections in blocks of 256 bytes for different security. The three different sections are BOOT, Application Code (APPCODE), and Application Data (APPDATA).

Figure 10-2. Flash Sections

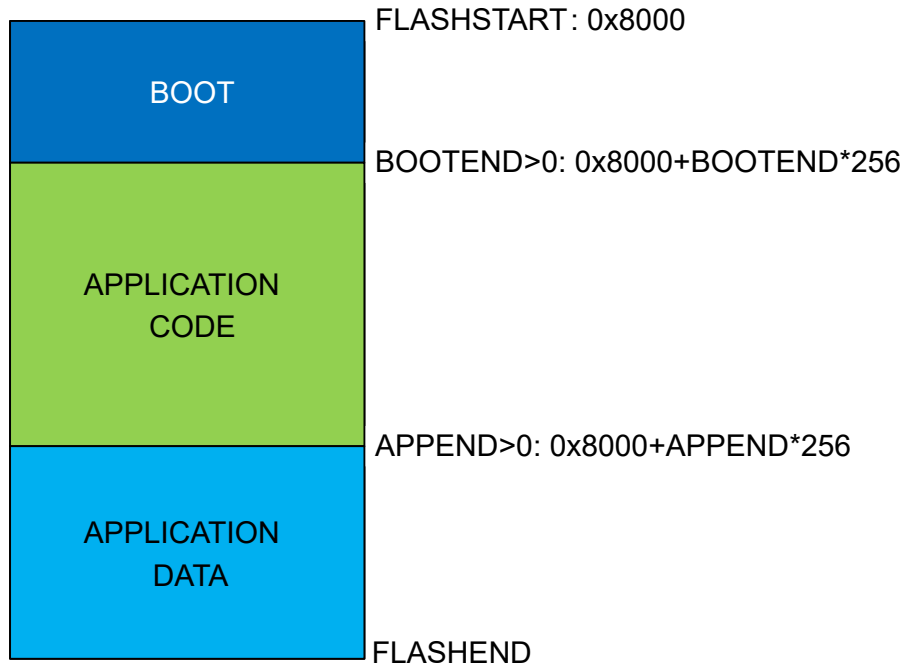

Section Sizes

The sizes of these sections are set by the Boot Section End (FUSE.BOOTEND) fuse and the Application Code Section End (FUSE.APPEND) fuse.

The fuses select the section sizes in blocks of 256 bytes. The BOOT section stretches from the start of the Flash until BOOTEND. The APPCODE section runs from BOOTEND until APPEND, and the remaining area is the APPDATA section.

Table 10-1. Setting Up Flash Sections

BOOTEND	APPEND	BOOT Section	APPCODE Section	APPDATA Section
0	–	0 to FLASHEND	–	–
> 0	0	0 to 256*BOOTEND	256*BOOTEND to FLASHEND	–
> 0	≤ BOOTEND	0 to 256*BOOTEND	–	256*BOOTEND to FLASHEND
> 0	> BOOTEND	0 to 256*BOOTEND	256*BOOTEND to 256*APPEND	256*APPEND to FLASHEND

If BOOTEND is written to '0', the entire Flash is regarded as the BOOT section. If APPEND is written to '0' and $\text{BOOTEND} > 0$, the APPCODE section runs from BOOTEND to the end of Flash (no APPDATA section). When $\text{APPEND} \leq \text{BOOTEND}$, the APPCODE section is removed, and the APPDATA runs from BOOTEND to the end of Flash. When $\text{APPEND} > \text{BOOTEND}$, the APPCODE section spreads from BOOTEND until APPEND. The remaining area is the APPDATA section.

If there is no boot loader software, it is recommended to use the BOOT section for Application Code.

Notes:

1. After Reset, the default vector table location is at the start of the APPCODE section. The peripheral interrupts can be used in the code running in the BOOT section by relocating the interrupt vector table at the beginning of this section. That is done by setting the IVSEL bit in the CPUINT.CTRLA register. Refer to the *CPUINT* section for details.
2. If BOOTEND/APPEND, as resulted from BOOTEND and APPEND fuse setting, exceed the device FLASHEND, the corresponding fuse setting is ignored, and the default value is used. Refer to "Fuse" in the *Memories* section for default values.

Example 10-1. Size of Flash Sections

If FUSE.BOOTEND is written to 0x04 and FUSE.APPEND is written to 0x08, the first 4*256 bytes will be BOOT, the next 4*256 bytes will be APPCODE, and the remaining Flash will be APPDATA.

Inter-Section Write Protection

Between the three Flash sections, directional write protection is implemented:

- The code in the BOOT section can write to APPCODE and APPDATA
- The code in APPCODE can write to APPDATA
- The code in APPDATA cannot write to Flash or EEPROM

Boot Section Lock and Application Code Section Write Protection

Additional to the inter-section write protection, the NVMCTRL provides a security mechanism to avoid unwanted access to the Flash memory sections. Even if the CPU can never write to the BOOT section, a Boot Section Lock (BOOTLOCK) bit in the Control B (NVMCTRL.CTRLB) register is provided to prevent the read and execution of code from the BOOT section. This bit can be set only from the code executed in the BOOT section and has effect only when leaving the BOOT section.

The Application Code Section Write Protection (APCWP) bit in the Control B (NVMCTRL.CTRLB) register can be set to prevent further updates of the APPCODE section.

10.3.1.2 EEPROM

The EEPROM is divided into a set of pages where one page consists of multiple bytes. The EEPROM has byte granularity on the erase/write. Within one page, only the bytes marked to be updated will be erased/written. The byte is marked by writing a new value to the page buffer for that address location.

10.3.1.3 User Row

The User Row is one extra page of EEPROM. This page can be used to store various data, such as calibration/configuration data and serial numbers. This page is not erased by a chip erase. The User Row is written as normal EEPROM, but also, it can be written through UPDI on a locked device.

10.3.2 Memory Access

10.3.2.1 Read

Reading of the Flash and EEPROM is done by using load instructions with an address according to the memory map. Reading any of the arrays while a write or erase is in progress will result in a bus wait, and the instruction will be suspended until the ongoing operation is complete.

10.3.2.2 Page Buffer Load

The page buffer is loaded by writing directly to the memories as defined in the memory map. The Flash, EEPROM, and User Row share the same page buffer, so only one section can be programmed at a time. The Least Significant bits (LSb) of the address are used to select where in the page buffer data are written. The resulting data will be a binary AND operation between the new and the previous content of the page buffer. The page buffer will automatically be erased (all bits set) after:

- A device Reset
- Any page write or erase operation
- A Clear Page Buffer command

- A device wake-up from any sleep mode

10.3.2.3 Programming

For page programming, filling the page buffer and writing the page buffer into Flash, User Row, and EEPROM are two separate operations.

Before programming a Flash page with the data in the page buffer, the Flash page must be erased. The page buffer is also erased when the device enters a sleep mode. Programming an unerased Flash page will corrupt its content.

The Flash can either be written with the erase and write separately, or one command handling both:

Alternative 1:

1. Fill the page buffer.
2. Write the page buffer to Flash with the Erase and Write Page (ERWP) command.

Alternative 2:

1. Write to a location on the page to set up the address.
2. Perform an Erase Page (ER) command.
3. Fill the page buffer.
4. Perform a Write Page (WP) command.

The NVM command set supports both a single erase and write operation, and split Erase Page (ER) and Write Page (WP) commands. This split commands enable shorter programming time for each command, and the erase operations can be done during non-time-critical programming execution.

The EEPROM programming is similar, but only the bytes updated in the page buffer will be written or erased in the EEPROM.

10.3.2.4 Commands

Reading the Flash/EEPROM and writing the page buffer is handled with normal load/store instructions. Other operations, such as writing and erasing the memory arrays, are handled by commands in the NVM.

To execute a command in the NVM:

1. Confirm that any previous operation is completed by reading the Busy (EEBUSY and FBUSY) Flags in the NVMCTRL.STATUS register.
2. Write the appropriate key to the Configuration Change Protection (CPU.CCP) register to unlock the NVM Control A (NVMCTRL.CTRLA) register.
3. Write the desired command value to the CMD bit field in the Control A (NVMCTRL.CTRLA) register within the next four instructions.

10.3.2.4.1 Write Page Command

The Write Page (WP) command of the Flash controller writes the content of the page buffer to the Flash or EEPROM.

If the write is to the Flash, the CPU will stop executing code as long as the Flash is busy with the write operation. If the write is to the EEPROM, the CPU can continue to execute code while the operation is ongoing.

The page buffer will automatically be cleared after the operation is finished.

10.3.2.4.2 Erase Page Command

The Erase Page (ER) command erases the current page. There must be one byte written in the page buffer for the Erase Page (ER) command to take effect.

For erasing the Flash, first, write to one address on the desired page, then execute the command. The whole page in the Flash will then be erased. The CPU will be halted while the erase is ongoing.

For the EEPROM, only the bytes written in the page buffer will be erased when the command is executed. To erase a specific byte, write to its corresponding address before executing the command. To erase a whole page, all the bytes in the page buffer have to be updated before executing the command. The CPU can continue running code while the operation is ongoing.

The page buffer will automatically be cleared after the operation is finished.

10.3.2.4.3 Erase/Write Page Command

The Erase and Write Page (ERWP) command is a combination of the Erase Page and Write Page commands, but without clearing the page buffer after the Erase Page command: The erase/write operation first erases the selected page, then it writes the content of the page buffer to the same page.

When executed on the Flash, the CPU will be halted when the operations are ongoing. When executed on EEPROM, the CPU can continue to execute code.

The page buffer will automatically be cleared after the operation is finished.

10.3.2.4.4 Page Buffer Clear Command

The Page Buffer Clear (PBC) command clears the page buffer. The contents of the page buffer will be all '1's after the operation. The CPU will be halted when the operation executes (seven CPU cycles).

10.3.2.4.5 Chip Erase Command

The Chip Erase (CHER) command erases the Flash and the EEPROM. The EEPROM is unaltered if the EEPROM Save During Chip Erase (EESAVE) fuse in FUSE.SYSCFG0 is set. The Flash will not be protected by Boot Section Lock (BOOTLOCK) bit or Application Code Section Write Protection (APCWP) bit in NVMCTRL.CTRLB register. The memory will be all '1's after the operation.

10.3.2.4.6 EEPROM Erase Command

The EEPROM Erase (EEER) command erases the EEPROM. The EEPROM will be all '1's after the operation. The CPU will be halted while the EEPROM is being erased.

10.3.2.4.7 Write Fuse Command

The Write Fuse (WFU) command writes the fuses. It can only be used by the UPDI; the CPU cannot start this command.

Follow this procedure to use the Write Fuse command:

1. Write the address of the fuse to the Address (NVMCTRL.ADDR) register.
2. Write the data to be written to the fuse to the Data (NVMCTRL.DATA) register.
3. Execute the Write Fuse command.
4. After the fuse is written, a Reset is required for the updated value to take effect.

For reading fuses, use a regular read on the memory location.

10.3.2.5 Write Access after Reset

After a Power-on Reset (POR), the NVMCTRL rejects any write attempts to the NVM for a given time. During this period, the Flash Busy (FBUSY) and the EEPROM Busy (EEBUSY) bit field in the NVMCTRL.STATUS register will read '1'. EEBUSY and FBUSY bit field must read '0' before the page buffer can be filled, or NVM commands can be issued.

This time-out period is disabled either by writing the Time-Out Disable (TOUTDIS) bit in the System Configuration 0 (FUSE.SYSCFG0) fuse to '0' or by configuring the RSTPINCFG bit field in FUSE.SYSCFG0 fuse to UPDI.

10.3.3 Preventing Flash/EEPROM Corruption

A Flash/EEPROM write or erase can cause memory corruption if the supply voltage is too low for the CPU and the Flash/EEPROM to operate correctly. These issues are the same on-board level systems using Flash/EEPROM, and it is recommended to use the internal or an external Brown-out Detector (BOD) to ensure that the device is not operating at too low voltage.

When the voltage is too low, a Flash/EEPROM corruption may be caused by two circumstances:

1. A regular write sequence to the Flash, which requires a minimum voltage to operate correctly.
2. The CPU itself can execute instructions incorrectly when the supply voltage is too low.

The chip erase does not clear fuses. If the BOD is enabled by fuses before starting the Chip Erase command, it is automatically enabled at its previous configured level during the chip erase.

Refer to the *Electrical Characteristics* section for Maximum Frequency vs. V_{DD} .



Attention: Flash/EEPROM corruption can be avoided by taking the following measures:

1. Keep the device in Reset during periods of an insufficient power supply voltage. Do this by enabling the internal BOD.
2. The Voltage Level Monitor (VLM) in the BOD can be used to prevent starting a write to the EEPROM close to the BOD level.
3. If the detection levels of the internal BOD do not match the required detection level, an external V_{DD} Reset protection circuit can be used. If a Reset occurs while a write operation is ongoing, the write operation will be aborted.

10.3.4 Interrupts

Table 10-2. Available Interrupt Vectors and Sources

Name	Vector Description	Conditions
EEREADY	NVM	The EEPROM is ready for new write/erase operations.

When an interrupt condition occurs, the corresponding interrupt flag is set in the Interrupt Flags (NVMCTRL.INTFLAGS) register.

An interrupt source is enabled or disabled by writing to the corresponding bit in the Interrupt Control (NVMCTRL.INTCTRL) register.

An interrupt request is generated when the corresponding interrupt source is enabled, and the interrupt flag is set. The interrupt request remains active until the interrupt flag is cleared. See the NVMCTRL.INTFLAGS register for details on how to clear interrupt flags.

10.3.5 Sleep Mode Operation

If there is no ongoing write operation, the NVMCTRL will enter a sleep mode when the system enters a sleep mode.

If a write operation is ongoing when the system enters a sleep mode, the NVM block, the NVM Controller, and the system clock will remain ON until the write is finished. This is valid for all sleep modes, including Power-Down sleep mode.

The EEPROM Ready interrupt will wake up the device only from Idle sleep mode.

The page buffer is cleared when waking up from sleep.

10.3.6 Configuration Change Protection

This peripheral has registers that are under Configuration Change Protection (CCP). To write to these registers, a certain key must first be written to the CPU.CCP register, followed by a write access to the protected bits within four CPU instructions.

Attempting to write to a protected register without following the appropriate CCP unlock sequence leaves the protected register unchanged.

The following registers are under CCP:

Table 10-3. NVMCTRL - Registers under Configuration Change Protection

Register	Key
NVMCTRL.CTRLA	SPM
NVMCTRL.CTRLB	IOREG

10.4 Register Summary

Offset	Name	Bit Pos.	7	6	5	4	3	2	1	0
0x00	CTRLA	7:0							CMD[2:0]	
0x01	CTRLB	7:0							BOOTLOCK	APCWP
0x02	STATUS	7:0						WRERROR	EEBUSY	FBUSY
0x03	INTCTRL	7:0								EEREADY
0x04	INTFLAGS	7:0								EEREADY
0x05	Reserved									
0x06	DATA	7:0	DATA[7:0]							
		15:8	DATA[15:8]							
0x08	ADDR	7:0	ADDR[7:0]							
		15:8	ADDR[15:8]							

10.5 Register Description

ATtiny3224/3226/3227

NVMCTRL - Nonvolatile Memory Controller

10.5.1 Control A

Name: CTRLA
Offset: 0x00
Reset: 0x00
Property: Configuration Change Protection

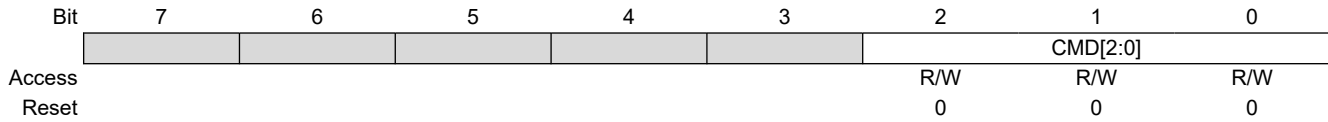

Bits 2:0 – CMD[2:0] Command

Write this bit field to issue a command. The Configuration Change Protection key for self-programming (SPM) has to be written within four instructions before this write.

Value	Name	Description
0x0	-	No command
0x1	WP	Write page buffer to memory (NVMCTRL.ADDR selects which memory)
0x2	ER	Erase page (NVMCTRL.ADDR selects which memory)
0x3	ERWP	Erase and write page (NVMCTRL.ADDR selects which memory)
0x4	PBC	Page buffer clear
0x5	CHER	Chip erase: Erase Flash and EEPROM (unless EESAVE in FUSE.SYSCFG is '1')
0x6	EEER	EEPROM Erase
0x7	WFU	Write fuse (only accessible through UPDI)

10.5.2 Control B

Name: CTRLB
Offset: 0x01
Reset: 0x00
Property: Configuration Change Protection

	7	6	5	4	3	2	1	0
							BOOTLOCK	APCWP
Access							R/W	R/W
Reset							0	0

Bit 1 – BOOTLOCK Boot Section Lock

Writing this bit to '1' locks the BOOT section from reading and instruction fetching.

If this bit is '1', a read from the BOOT section will return '0'. A fetch from the BOOT section will also return '0' as instruction.

This bit can be written from the BOOT section only. It can only be cleared to '0' by a Reset.

This bit will take effect only when the BOOT section is left the first time after the bit is written.

Bit 0 – APCWP Application Code Section Write Protection

Writing this bit to '1' prevents further updates to the Application Code section.

This bit can only be written to '1'. It is cleared to '0' only by Reset.

ATtiny3224/3226/3227

NVMCTRL - Nonvolatile Memory Controller

10.5.3 Status

Name: STATUS
Offset: 0x02
Reset: 0x00
Property: -

Bit	7	6	5	4	3	2	1	0
						WRERROR	EEBUSY	FBUSY
Access						R	R	R
Reset						0	0	0

Bit 2 – WRERROR Write Error

This bit will read '1' when a write error has happened. A write error could be writing to different sections before doing a page write or writing to a protected area. This bit is valid for the last operation.

Bit 1 – EEBUSY EEPROM Busy

This bit will read '1' when the EEPROM is busy with a command.

Bit 0 – FBUSY Flash Busy

This bit will read '1' when the Flash is busy with a command.

10.5.4 Interrupt Control

Name: INTCTRL
Offset: 0x03
Reset: 0x00
Property: -

Bit	7	6	5	4	3	2	1	0
								EEREADY
Access								R/W
Reset								0

Bit 0 – EEREADY EEPROM Ready Interrupt

Writing a '1' to this bit enables the interrupt, which indicates that the EEPROM is ready for new write/erase operations.

This is a level interrupt that will be triggered only when the EEREADY flag in the INTFLAGS register is set to '0'. Thus, the interrupt must not be enabled before triggering an NVM command, as the EEREADY flag will not be set before the NVM command is issued. The interrupt may be disabled in the interrupt handler.

10.5.5 Interrupt Flags

Name: INTFLAGS
Offset: 0x04
Reset: 0x00
Property: -

Bit	7	6	5	4	3	2	1	0
Access								EEREADY
Reset								0

Bit 0 – EEREADY EEREADY Interrupt Flag

This flag is set continuously as long as the EEPROM is not busy. This flag is cleared by writing a '1' to it.

ATtiny3224/3226/3227

NVMCTRL - Nonvolatile Memory Controller

10.5.6 Data

Name: DATA
Offset: 0x06
Reset: 0x00
Property: -

The NVMCTRL.DATAL and NVMCTRL.DATAH register pair represents the 16-bit value, NVMCTRL.DATA. The low byte [7:0] (suffix L) is accessible at the original offset. The high byte [15:8] (suffix H) can be accessed at offset + 0x01.

	Bit	15	14	13	12	11	10	9	8
		DATA[15:8]							
Access		R/W	R/W	R/W	R/W	R/W	R/W	R/W	R/W
Reset		0	0	0	0	0	0	0	0
	Bit	7	6	5	4	3	2	1	0
		DATA[7:0]							
Access		R/W	R/W	R/W	R/W	R/W	R/W	R/W	R/W
Reset		0	0	0	0	0	0	0	0

Bits 15:0 – DATA[15:0] Data Register

This register is used by the UPDI for fuse write operations.

ATtiny3224/3226/3227

NVMCTRL - Nonvolatile Memory Controller

10.5.7 Address

Name: ADDR
Offset: 0x08
Reset: 0x00
Property: -

The NVMCTRL.ADDRL and NVMCTRL.ADDRH register pair represents the 16-bit value, NVMCTRL.ADDR. The low byte [7:0] (suffix L) is accessible at the original offset. The high byte [15:8] (suffix H) can be accessed at offset + 0x01.

	Bit	15	14	13	12	11	10	9	8
		ADDR[15:8]							
Access		R/W	R/W	R/W	R/W	R/W	R/W	R/W	R/W
Reset		0	0	0	0	0	0	0	0
	Bit	7	6	5	4	3	2	1	0
		ADDR[7:0]							
Access		R/W	R/W	R/W	R/W	R/W	R/W	R/W	R/W
Reset		0	0	0	0	0	0	0	0

Bits 15:0 – ADDR[15:0] Address

The Address register contains the address to the last memory location that has been updated.

11. CLKCTRL - Clock Controller

11.1 Features

- All Clocks and Clock Sources are Automatically Enabled when Requested by Peripherals
- Internal Oscillators:
 - 20 MHz oscillator (OSC20M)
 - 32.768 kHz Ultra Low-Power Oscillator (OSCULP32K)
- External Clock Options:
 - 32.768 kHz crystal oscillator (XOSC32K)
 - External clock
- Main Clock Features:
 - Safe run-time switching
 - Prescaler with 1x to 64x division in 12 different settings

11.2 Overview

The Clock Controller (CLKCTRL) controls, distributes and prescales the clock signals from the available oscillators, and supports internal and external clock sources.

The CLKCTRL is based on an automatic clock request system, implemented in all peripherals on the device. The peripherals will automatically request the clocks needed. The request is routed to the correct clock source if multiple clock sources are available.

The Main Clock (CLK_MAIN) is used by the CPU, RAM, and all peripherals connected to the I/O bus. The main clock source can be selected and prescaled. Some peripherals can share the same clock source as the main clock or run asynchronously to the main clock domain.

11.2.1 Block Diagram - CLKCTRL

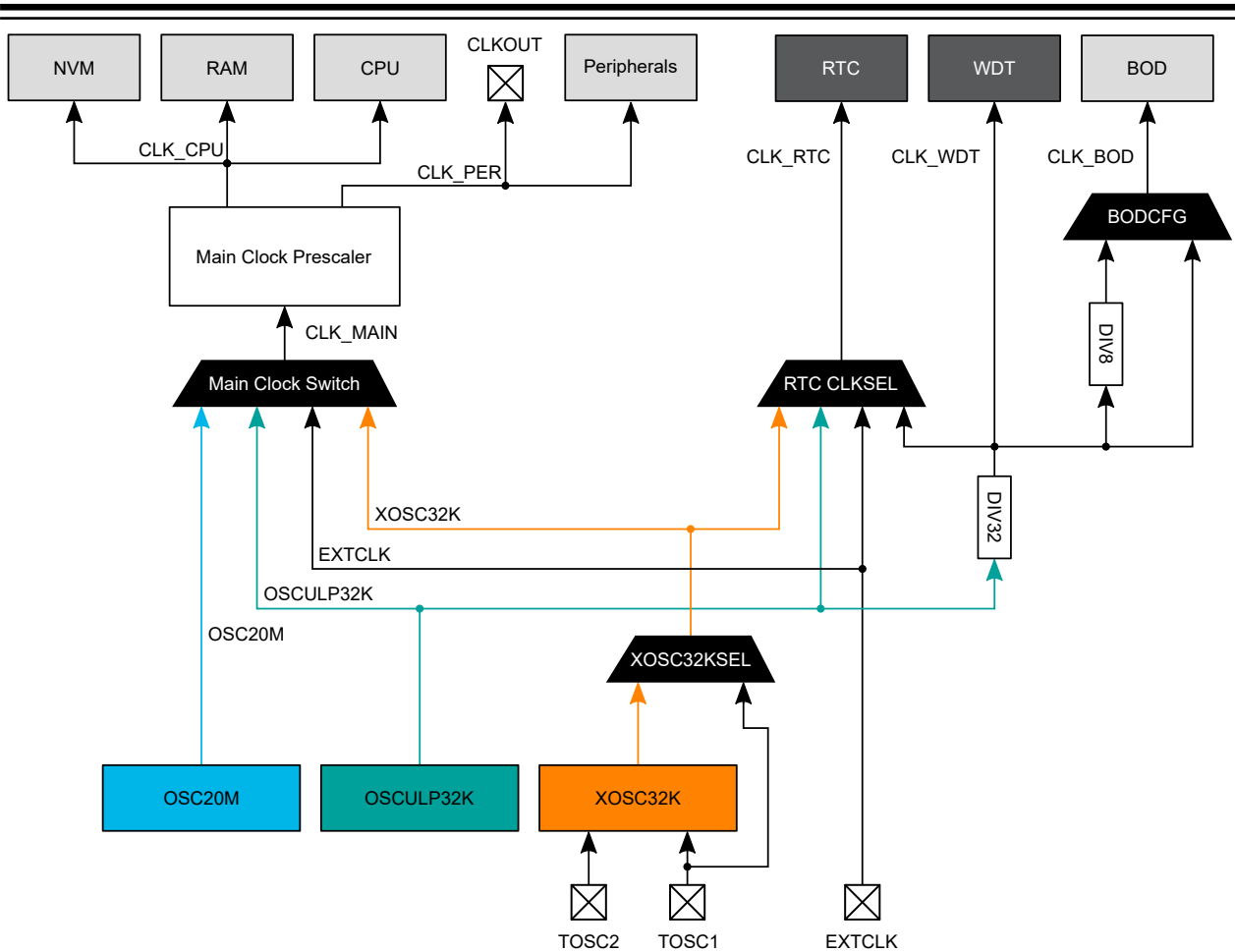

The clock system consists of the main clock and other asynchronous clocks:

- Main Clock
 - This clock is used by the CPU, RAM, Flash, the I/O bus, and all peripherals connected to the I/O bus. It is always running in Active and Idle Sleep mode and can be running in Standby Sleep mode if requested.
 - The main clock CLK_MAIN is prescaled and distributed by the clock controller:
 - CLK_CPU is used by the CPU, SRAM, and the NVMCTRL peripheral to access the nonvolatile memory
 - CLK_PER is used by all peripherals that are not listed under asynchronous clocks
- Clocks running asynchronously to the main clock domain:
 - CLK_RTC is used by the RTC/PIT. It will be requested when the RTC/PIT is enabled. The clock source for CLK_RTC may only be changed if the peripheral is disabled.
 - CLK_WDT is used by the WDT. It will be requested when the WDT is enabled.
 - CLK_BOD is used by the BOD. It will be requested when the BOD is enabled in Sampled mode.

The clock source for the for the main clock domain is configured by writing to the Clock Select bits (CLKSEL) in the Main Clock Control A register (CLKCTRL.MCLKCTRLA). The asynchronous clock sources are configured by registers in the respective peripheral.

11.2.2 Signal Description

Signal	Type	Description
CLKOUT	Digital output	CLK_PER output

11.3 Functional Description

11.3.1 Sleep Mode Operation

When a clock source is not used or requested, it will stop. It is possible to request a clock source directly by writing a '1' to the Run Standby (RUNSTDBY) bit in the respective oscillator's Control A (CLKCTRL.[osc]CTRLA) register. This will cause the oscillator to run constantly, except for Power-Down sleep mode. Additionally, when this bit is written to '1', the oscillator start-up time is eliminated when the clock source is requested by a peripheral.

The main clock will always run in Active and Idle sleep modes. In Standby sleep mode, the main clock will run only if any peripheral is requesting it, or the Run in Standby (RUNSTDBY) bit in the respective oscillator's Control A (CLKCTRL.[osc]CTRLA) register is written to '1'.

In Power-Down sleep mode, the main clock will stop after all NVM operations are completed. Refer to the *Sleep Controller* section for more details on sleep mode operation.

11.3.2 Main Clock Selection and Prescaler

All internal oscillators can be used as the main clock source for CLK_MAIN. The main clock source is selectable from software and can be safely changed during normal operation.

Built-in hardware protection prevents unsafe clock switching:

Upon selection of an external clock source, a switch to the chosen clock source will only occur if edges are detected. Until a sufficient number of clock edges are detected the switch will not occur, and it will not be possible to change to another clock source again without executing a Reset.

An ongoing clock source switch is indicated by the System Oscillator Changing flag (SOSC) in the Main Clock Status register (CLKCTRL.MCLKSTATUS). The stability of the external clock sources is indicated by the respective status flags (EXTS and XOSC32KS in CLKCTRL.MCLKSTATUS).

CAUTION

1. If an external clock source fails while used as the CLK_MAIN source, only the WDT can provide a mechanism to switch back via System Reset.
2. Do not alter the properties of the external clock source while used as the CLK_MAIN source. This can be interpreted as a clock failure.

CLK_MAIN is fed into a prescaler before it is used by the peripherals (CLK_PER) in the device. The prescaler divide CLK_MAIN by a factor from 1 to 64.

Figure 11-1. Main Clock and Prescaler

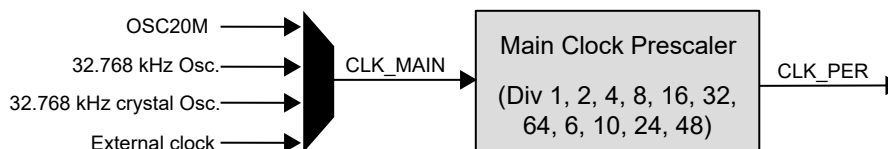

The Main Clock and Prescaler configuration registers (CLKCTRL.MCLKCTRLA, CLKCTRL.MCLKCTRLB) are protected by the Configuration Change Protection Mechanism, employing a timed write procedure for changing these registers.

11.3.3 Main Clock After Reset

After any Reset, CLK_MAIN is provided by the 20 MHz Oscillator (OSC20M) and with a prescaler division factor of 6. The actual frequency of the OSC20M is determined by the Frequency Select bits (FREQSEL) of the Oscillator Configuration fuse (FUSE.OSCCFG). Refer to the description of FUSE.OSCCFG for details of the possible frequencies after Reset.

11.3.4 Clock Sources

The clock sources are divided into two main groups: internal oscillators and external clock sources. All the internal clock sources are automatically enabled when they are requested by a peripheral.

The crystal oscillator must be enabled by writing a '1' to the ENABLE bit in the 32.768 kHz Crystal Oscillator Control A (CLKCTRL.XOSC32KCTRLA) register before it can serve as a clock source.

After Reset, the device starts running from the internal high-frequency oscillator or the internal 32.768 kHz oscillator.

The respective Oscillator Status bits in the Main Clock Status (CLKCTRL.MCLKSTATUS) register indicate if the clock source is running and stable.

11.3.4.1 Internal Oscillators

The internal oscillators do not require any external components to run. See the related links for accuracy and electrical characteristics.

11.3.4.1.1 20 MHz Oscillator (OSC20M)

This oscillator can operate at multiple frequencies, selected by the value of the Frequency Select bits (FREQSEL) in the Oscillator Configuration Fuse (FUSE.OSCCFG).

After a system Reset, FUSE.OSCCFG determines the initial frequency of CLK_MAIN.

During Reset, the calibration values for the OSC20M are loaded from fuses. There are two different calibration bit fields. The Calibration bit field (CAL20M) in the Calibration A register (CLKCTRL.OSC20MCALIBA) enables calibration around the current center frequency. The Oscillator Temperature Coefficient Calibration bit field (TEMPCAL20M) in the Calibration B register (CLKCTRL.OSC20MCALIBB) enables adjustment of the slope of the temperature drift compensation.

For applications requiring more fine-tuned frequency than provided by the oscillator calibration, the remaining oscillator frequency error measured during calibration is available in the Signature Row (SIGROW) for additional compensation.

The oscillator calibration can be locked by the Oscillator Lock (OSCLOCK) Fuse (FUSE.OSCCFG). When this fuse is '1', it is not possible to change the calibration. The calibration is locked if this oscillator is used as the main clock source and the Lock Enable bit (LOCKEN) in the Control B register (CLKCTRL.OSC20MCALIBB) is '1'.

The calibration bits are protected by the Configuration Change Protection Mechanism, requiring a timed write procedure for changing the main clock and prescaler settings.

Refer to the *Electrical Characteristics* section for the start-up time.

OSC20M Stored Frequency Error Compensation

This oscillator can operate at multiple frequencies, selected by the value of the Frequency Select bits (FREQSEL) in the Oscillator Configuration fuse (FUSE.OSCCFG) at Reset. As previously mentioned, appropriate calibration values are loaded to adjust to center frequency (OSC20M), and temperature drift compensation (TEMPCAL20M), meeting the specifications defined in the internal oscillator characteristics. For applications requiring a wider operating range, the relative factory stored frequency error after calibrations can be used. The four errors are measured at different settings and are available in the signature row as signed byte values.

- SIGROW.OSC16ERR3V is the frequency error from 16 MHz measured at 3V
- SIGROW.OSC16ERR5V is the frequency error from 16 MHz measured at 5V
- SIGROW.OSC20ERR3V is the frequency error from 20 MHz measured at 3V
- SIGROW.OSC20ERR5V is the frequency error from 20 MHz measured at 5V

The error is stored as a compressed **Q1.10** fixed point 8-bit value in order not to lose resolution, where the MSb is the sign bit and the seven LSb the lower bits of the **Q1.10**.

$$BAUD_{actual} = \left(BAUD_{ideal} + \frac{BAUD_{ideal} * SigRowError}{1024} \right)$$

The minimum legal BAUD register value is 0x40. The target BAUD register value may therefore not be lower than 0x4A to ensure that the compensated BAUD value stays within the legal range, even for parts with negative

compensation values. The example code below demonstrates how to apply this value for a more accurate USART baud rate:

```
#include <assert.h>
/* Baud rate compensated with factory stored frequency error */
/* Asynchronous communication without Auto-baud (Sync ) */
/* 16MHz Clock, 3V and 600 BAUD */

int8_t sigrow_val = SIGROW.OSC16ERR3V; // read signed error
int32_t baud_reg_val = 600; // ideal BAUD register value

assert (baud_reg_val >= 0x4A); // Verify legal min BAUD register value with
max neg comp
baud_reg_val *= (1024 + sigrow_val); // sum resolution + error
baud_reg_val /= 1024; // divide by resolution
USART0.BAUD = (int16_t) baud_reg_val; // set adjusted baud rate
```

11.3.4.1.2 32.768 kHz Oscillator (OSCULP32K)

The 32.768 kHz oscillator is optimized for Ultra Low-Power (ULP) operation. Power consumption is decreased at the cost of decreased accuracy compared to an external crystal oscillator.

This oscillator provides the 1.024 kHz signal for the Real-Time Counter (RTC), the Watchdog Timer (WDT), and the Brown-out Detector (BOD).

The start-up time of this oscillator is the oscillator start-up time plus four oscillator cycles. Refer to section *Electrical Characteristics* for the start-up time.

11.3.4.2 External Clock Sources

These external clock sources are available:

- External Clock from a pin (EXTCLK).
- The TOSC1 and TOSC2 pins are dedicated to driving a 32.768 kHz crystal oscillator (XOSC32K).
- Instead of a crystal oscillator, TOSC1 can be configured to accept an external clock source.

11.3.4.2.1 32.768 kHz Crystal Oscillator (XOSC32K)

This oscillator supports two input options: Either a crystal is connected to the pins TOSC1 and TOSC2, or an external clock running at 32.768 kHz is connected to TOSC1. The input option must be configured by writing the Source Select (SEL) bit in the XOSC32K Control A (CLKCTRL.XOSC32KCTRLA) register.

The XOSC32K is enabled by writing a '1' to its ENABLE bit in CLKCTRL.XOSC32KCTRLA. When enabled, the configuration of the GPIO pins used by the XOSC32K is overridden as TOSC1 and TOSC2 pins. The Enable bit needs to be set for the oscillator to start running when requested.

The start-up time of a given crystal oscillator can be accommodated by writing to the Crystal Start-up Time bits (CSUT) in CLKCTRL.XOSC32KCTRLA.

When XOSC32K is configured to use an external clock on TOSC1, the start-up time is fixed to two cycles.

11.3.4.2.2 External Clock (EXTCLK)

The EXTCLK is taken directly from the pin. This GPIO pin is automatically configured for EXTCLK if any peripheral is requesting this clock.

This clock source has a start-up time of two cycles when first requested.

11.3.5 Configuration Change Protection

This peripheral has registers that are under Configuration Change Protection (CCP). To write to these registers, a certain key must first be written to the CPU.CCP register, followed by a write access to the protected bits within four CPU instructions.

Attempting to write to a protected register without following the appropriate CCP unlock sequence leaves the protected register unchanged.

The following registers are under CCP:

Table 11-1. CLKCTRL - Registers Under Configuration Change Protection

Register	Key
CLKCTRL.MCLKCTRLB	IOREG
CLKCTRL.MCLKLOCK	IOREG
CLKCTRL.XOSC32KCTRLA	IOREG
CLKCTRL.MCLKCTRLA	IOREG
CLKCTRL.OSC20MCTRLA	IOREG
CLKCTRL.OSC20MCALIBA	IOREG
CLKCTRL.OSC20MCALIBB	IOREG
CLKCTRL.OSC32KCTRLA	IOREG

11.4 Register Summary

Offset	Name	Bit Pos.	7	6	5	4	3	2	1	0
0x00	MCLKCTRLA	7:0	CLKOUT						CLKSEL[1:0]	
0x01	MCLKCTRLB	7:0					PDIV[3:0]			PEN
0x02	MCLKLOCK	7:0								LOCKEN
0x03	MCLKSTATUS	7:0	EXTS	XOSC32KS	OSC32KS	OSC20MS				SOSC
0x04 ... 0x0F	Reserved									
0x10	OSC20MCTRLA	7:0							RUNSTDBY	
0x11	OSC20MCALIBA	7:0					CAL20M[6:0]			
0x12	OSC20MCALIBB	7:0	LOCK					TEMPCAL20M[3:0]		
0x13 ... 0x17	Reserved									
0x18	OSC32KCTRLA	7:0							RUNSTDBY	
0x19 ... 0x1B	Reserved									
0x1C	XOSC32KCTRLA	7:0			CSUT[1:0]			SEL	RUNSTDBY	ENABLE

11.5 Register Description

11.5.1 Main Clock Control A

Name: MCLKCTRLA
Offset: 0x00
Reset: 0x00
Property: Configuration Change Protection

Bit	7	6	5	4	3	2	1	0
	CLKOUT						CLKSEL[1:0]	
Access	R/W						R/W	R/W
Reset	0						0	0

Bit 7 – CLKOUT System Clock Out

When this bit is written to '1', the system clock is output to the CLKOUT pin.

When the device is in a Sleep mode, there is no clock output unless a peripheral is using the system clock.

Bits 1:0 – CLKSEL[1:0] Clock Select

This bit field selects the source for the Main Clock (CLK_MAIN).

Value	Name	Description
0x0	OSC20M	20 MHz internal oscillator
0x1	OSCU32K	32.768 kHz internal ultra low-power oscillator
0x2	XOSC32K	32.768 kHz external crystal oscillator
0x3	EXTCLK	External clock

11.5.2 Main Clock Control B

Name: MCLKCTRLB
Offset: 0x01
Reset: 0x11
Property: Configuration Change Protection

Bit	7	6	5	4	3	2	1	0
				PDIV[3:0]				PEN
Access				R/W	R/W	R/W	R/W	R/W
Reset				1	0	0	0	1

Bits 4:1 – PDIV[3:0] Prescaler Division

If the Prescaler Enable (PEN) bit is written to '1', these bits define the division ratio of the main clock prescaler. These bits can be written during run-time to vary the clock frequency of the system to suit the application requirements.

The user software must ensure a correct configuration of the input frequency (CLK_MAIN) and prescaler settings, so that the resulting frequency of CLK_PER never exceeds the allowed maximum (see *Electrical Characteristics*).

Value	Name	Description
0x0	DIV2	CLK_MAIN divided by 2
0x1	DIV4	CLK_MAIN divided by 4
0x2	DIV8	CLK_MAIN divided by 8
0x3	DIV16	CLK_MAIN divided by 16
0x4	DIV32	CLK_MAIN divided by 32
0x5	DIV64	CLK_MAIN divided by 64
0x6–0x7	-	Reserved
0x8	DIV6	CLK_MAIN divided by 6
0x9	DIV10	CLK_MAIN divided by 10
0xA	DIV12	CLK_MAIN divided by 12
0xB	DIV24	CLK_MAIN divided by 24
0xC	DIV48	CLK_MAIN divided by 48
other	-	Reserved

Bit 0 – PEN Prescaler Enable

This bit must be written to '1' to enable the prescaler. When enabled, the division ratio is selected by the PDIV bit field.

When this bit is written to '0', the main clock will pass through undivided (CLK_PER = CLK_MAIN), regardless of the value of PDIV.

11.5.3 Main Clock Lock

Name: MCLKLOCK
Offset: 0x02
Reset: Based on OSCLOCK in FUSE.OSCCFG
Property: Configuration Change Protection

Bit	7	6	5	4	3	2	1	0
								LOCKEN
Access								R/W
Reset								x

Bit 0 – LOCKEN Lock Enable

Writing this bit to '1' will lock the CLKCTRL.MCLKCTRLA and CLKCTRL.MCLKCTRLB registers, and, if applicable, the calibration settings for the current main clock source from further software updates. Once locked, the CLKCTRL.MCLKLOCK registers cannot be accessed until the next hardware Reset.

This provides protection for the CLKCTRL.MCLKCTRLA and CLKCTRL.MCLKCTRLB registers and calibration settings for the main clock source from unintentional modification by software.

At Reset, the LOCKEN bit is loaded based on the OSCLOCK bit in FUSE.OSCCFG.

11.5.4 Main Clock Status

Name: MCLKSTATUS
Offset: 0x03
Reset: 0x00
Property: -

Bit	7	6	5	4	3	2	1	0
	EXTS	XOSC32KS	OSC32KS	OSC20MS				SOSC
Access	R	R	R	R				R
Reset	0	0	0	0				0

Bit 7 – EXTS External Clock Status

Value	Description
0	EXTCLK has not started
1	EXTCLK has started

Bit 6 – XOSC32KS XOSC32K Status

The Status bit will only be available if the source is requested as the main clock or by another module. If the oscillator RUNSTDBY bit is set and the oscillator is unused/not requested, this bit will be '0'.

Value	Description
0	XOSC32K is not stable
1	XOSC32K is stable

Bit 5 – OSC32KS OSCULP32K Status

The Status bit will only be available if the source is requested as the main clock or by another module. If the oscillator RUNSTDBY bit is set and the oscillator is unused/not requested, this bit will be '0'.

Value	Description
0	OSCULP32K is not stable
1	OSCULP32K is stable

Bit 4 – OSC20MS OSC20M Status

The Status bit will only be available if the source is requested as the main clock or by another module. If the oscillator RUNSTDBY bit is set and the oscillator is unused/not requested, this bit will be '0'.

Value	Description
0	OSC20M is not stable
1	OSC20M is stable

Bit 0 – SOSC Main Clock Oscillator Changing

Value	Description
0	The clock source for CLK_MAIN is not undergoing a switch
1	The clock source for CLK_MAIN is undergoing a switch and will change as soon as the new source is stable

11.5.5 20 MHz Oscillator Control A

Name: OSC20MCTRLA
Offset: 0x10
Reset: 0x00
Property: Configuration Change Protection

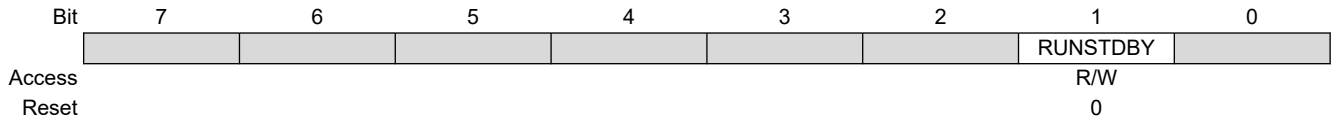

Bit 1 – RUNSTDBY Run Standby

This bit forces the oscillator ON in all modes, even when unused by the system. In Standby Sleep mode this can be used to ensure immediate wake-up and not waiting for oscillator start-up time.

When not requested by peripherals, no oscillator output is provided.

It takes four oscillator cycles to open the clock gate after a request but the oscillator analog start-up time will be removed when this bit is set.

11.5.6 20 MHz Oscillator Calibration A

Name: OSC20MCALIBA
Offset: 0x11
Reset: Based on FREQSEL in FUSE.OSCCFG
Property: Configuration Change Protection

	7	6	5	4	3	2	1	0
Bit	CAL20M[6:0]							
Access		R/W	R/W	R/W	R/W	R/W	R/W	R/W
Reset		x	x	x	x	x	x	x

Bits 6:0 – CAL20M[6:0] Calibration

These bits change the frequency around the current center frequency of the OSC20M for fine-tuning. At Reset, the factory-calibrated values are loaded based on the FREQSEL bit in FUSE.OSCCFG.

11.5.7 20 MHz Oscillator Calibration B

Name: OSC20MCALIBB
Offset: 0x12
Reset: Based on FUSE.OSCCFG
Property: Configuration Change Protection

Bit	7	6	5	4	3	2	1	0
	LOCK					TEMPCAL20M[3:0]		
Access	R				R/W	R/W	R/W	R/W
Reset	x				x	x	x	x

Bit 7 – LOCK Oscillator Calibration Locked by Fuse

When this bit is set, the calibration settings in CLKCTRL.OSC20MCALIBA and CLKCTRL.OSC20MCALIBB cannot be changed.

The Reset value is loaded from the OSCLOCK bit in the Oscillator Configuration Fuse (FUSE.OSCCFG).

Bits 3:0 – TEMPCAL20M[3:0] Oscillator Temperature Coefficient Calibration

These bits tune the slope of the temperature compensation.

At Reset, the factory-calibrated values are loaded based on the FREQSEL bits in FUSE.OSCCFG.

11.5.8 32.768 kHz Oscillator Control A

Name: OSC32KCTRLA
Offset: 0x18
Reset: 0x00
Property: Configuration Change Protection

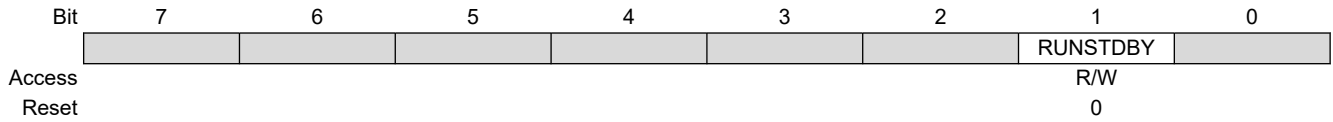

Bit 1 – RUNSTDBY Run Standby

This bit forces the oscillator ON in all modes, even when unused by the system. In Standby Sleep mode this can be used to ensure immediate wake-up and not waiting for the oscillator start-up time.

When not requested by peripherals, no oscillator output is provided.

It takes four oscillator cycles to open the clock gate after a request but the oscillator analog start-up time will be removed when this bit is set.

11.5.9 32.768 kHz Crystal Oscillator Control A

Name: XOSC32KCTRLA
Offset: 0x1C
Reset: 0x00
Property: Configuration Change Protection

The SEL and CSUT bits cannot be changed as long as the ENABLE bit is set or the XOSC32K Stable bit (XOSC32KS) in CLKCTRL.MCLKSTATUS is high.
 To change settings safely: Write a '0' to the ENABLE bit and wait until XOSC32KS is '0' before re-enabling the XOSC32K with new settings.

	Bit	7	6	5	4	3	2	1	0
		CSUT[1:0]					SEL	RUNSTDBY	ENABLE
Access		R/W			R/W		R/W	R/W	R/W
Reset		0			0		0	0	0

Bits 5:4 – CSUT[1:0] Crystal Start-Up Time

These bits select the start-up time for the XOSC32K. It is write-protected when the oscillator is enabled (ENABLE = 1).

If SEL = 1, the start-up time will not be applied.

Value	Name	Description
0x0	1K	1k cycles
0x1	16K	16k cycles
0x2	32K	32k cycles
0x3	64K	64k cycles

Bit 2 – SEL Source Select

This bit selects the external source type. It is write-protected when the oscillator is enabled (ENABLE = 1).

Value	Description
0	External crystal
1	External clock on TOSC1 pin

Bit 1 – RUNSTDBY Run Standby

Writing this bit to '1' starts the crystal oscillator and forces the oscillator ON in all modes, even when unused by the system if the ENABLE bit is set. In Standby Sleep mode, this can be used to ensure immediate wake-up and not waiting for oscillator start-up time. When this bit is '0', the crystal oscillator is only running when requested and the ENABLE bit is set.

The output of XOSC32K is not sent to other peripherals unless it is requested by one or more peripherals.

When the RUNSTDBY bit is set, there will only be a delay of two to three crystal oscillator cycles after a request until the oscillator output is received, if the initial crystal start-up time has already completed.

According to RUNSTDBY bit, the oscillator will be turned ON all the time if the device is in Active, Idle, or Standby Sleep mode, or only be enabled when requested.

This bit is I/O protected to prevent any unintentional enabling of the oscillator.

Bit 0 – ENABLE Enable

When this bit is written to '1', the configuration of the respective input pins is overridden to TOSC1 and TOSC2. Also, the Source Select bit (SEL) and Crystal Start-Up Time (CSUT) become read-only.

This bit is I/O protected to prevent any unintentional enabling of the oscillator.

12. SLPCTRL - Sleep Controller

12.1 Features

- Power Management for Adjusting Power Consumption and Functions
- Three Sleep Modes:
 - Idle
 - Standby
 - Power-Down
- Configurable Standby Mode Where Peripherals Can Be Configured as ON or OFF

12.2 Overview

Sleep modes are used to shut down peripherals and clock domains in the device to save power. The Sleep Controller (SLPCTRL) controls and handles the transitions between Active and sleep modes.

There are four modes available: One Active mode in which software is executed, and three sleep modes. The available sleep modes are Idle, Standby and Power-Down.

All sleep modes are available and can be entered from the Active mode. In Active mode, the CPU is executing application code. When the device enters sleep mode, the program execution is stopped. The application code decides which sleep mode to enter and when.

Interrupts are used to wake the device from sleep. The available interrupt wake-up sources depend on the configured sleep mode. When an interrupt occurs, the device will wake up and execute the Interrupt Service Routine before continuing normal program execution from the first instruction after the `SLEEP` instruction. Any Reset will take the device out of sleep mode.

The content of the register file, SRAM and registers, is kept during sleep. If a Reset occurs during sleep, the device will reset, start, and execute from the Reset vector.

12.2.1 Block Diagram

Figure 12-1. SLPCTRL Block Diagram

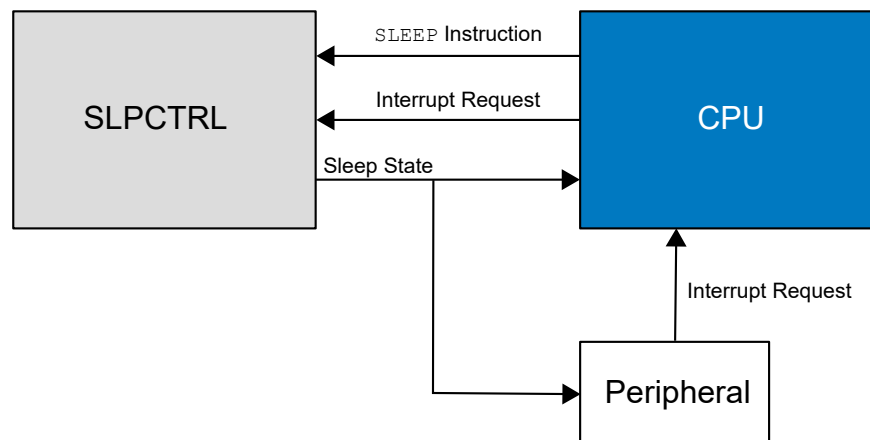

12.3 Functional Description

12.3.1 Initialization

To put the device into a sleep mode, follow these steps:

1. Configure and enable the interrupts that can wake the device from sleep.
Enable also the global interrupts.



If there are no interrupts enabled when going to sleep, the device cannot wake up again. Only a Reset will allow the device to continue operation.

2. Select which sleep mode to enter, and enable the Sleep Controller by writing to the Sleep Mode (SMODE) bit field and the Enable (SEN) bit in the Control A (SLPCTRL.CTRLA) register.
The `SLEEP` instruction must be executed to make the device go to sleep.

12.3.2 Operation

12.3.2.1 Sleep Modes

Three different sleep modes can be enabled to reduce power consumption.

- Idle** The CPU stops executing code, resulting in reduced power consumption. All peripherals are running, and all interrupt sources can wake the device.
- Standby** All high-frequency clocks are stopped apart from any peripheral or clock that are enabled to run in Standby sleep mode. This is enabled by writing the corresponding `RUNSTDBY` bit to '1'. The power consumption is dependent on the enabled functionality. A subset of interrupt sources can wake the device⁽¹⁾.
- Power-Down** All high-frequency clocks are stopped, resulting in a power consumption lower than the Idle sleep mode. A subset of the peripherals are running, and a subset of interrupt sources can wake the device⁽¹⁾.

Note:

1. Refer to the *Sleep Mode Activity* tables for further information.

Refer to the *Wake-up Time* section for information on how the wake-up time is affected by the different sleep modes.

Table 12-1. Sleep Mode Activity Overview for Peripherals

Clock	Peripheral	Active in Sleep Mode		
		Idle	Standby	Power-Down
CLK_CPU	CPU	-	-	-
CLK_RTC	RTC	X	X ^(1,2)	X ⁽²⁾
CLK_WDT	WDT	X	X	X
CLK_BOD ⁽³⁾	BOD	X	X	X
⁽⁴⁾	CCL	X	X ⁽¹⁾	-
CLK_PER	ADCn	X	X ⁽¹⁾	-
	TCA _n			
	TCB _n			
	All other peripherals	X	-	-

Notes:

1. Set the `RUNSTDBY` bit of the corresponding peripheral to enter an active state.
2. In Standby sleep mode, only the RTC functionality requires the `RUNSTDBY` to be set to enter an active state. In Power-Down sleep mode, only the PIT functionality is available.
3. Sampled mode only.
4. The clock domain depends on the clock source selected for CCL.

Table 12-2. Sleep Mode Activity Overview for Clock Sources

Clock Source	Active in Sleep Mode		
	Idle	Standby	Power-Down
Main clock source	X	X ⁽¹⁾	-
RTC clock source	X	X ^(1,2)	X ⁽²⁾
WDT oscillator	X	X	X
BOD oscillator ⁽³⁾	X	X	X
CCL clock source	X	X ⁽¹⁾	-

Notes:

1. Write the RUNSTDBY bit of the corresponding peripheral to enter an active state.
2. In Standby sleep mode, only the RTC functionality requires the RUNSTDBY to be set to enter an active state. In Power-Down sleep mode, only the PIT functionality is available.
3. Sampled mode only.

Table 12-3. Sleep Mode Wake-Up Sources

Wake-Up Source	Active in Sleep Mode		
	Idle	Standby	Power-Down
PORT Pin interrupt	X	X	X ⁽¹⁾
TWI Address Match interrupt	X	X	X
BOD VLM interrupt	X	X	X
CCL interrupts	X	X ^(2,3)	X ⁽³⁾
RTC interrupts	X	X ^(2,4)	X ⁽⁴⁾
USART interrupts	X ⁽⁵⁾	X ⁽⁶⁾	-
TCA _n interrupts	X	X ⁽²⁾	-
TCB _n interrupts			
ADC _n interrupts			
AC _n Compare interrupt			
All other interrupts	X	-	-

Notes:

1. The I/O pin must be configured according to *Asynchronous Sensing Pin Properties* in the PORT section.
2. Set the RUNSTDBY bit of the corresponding peripheral to enter an active state.
3. CCL can wake up the device if the path through LUT_n is asynchronous (FILTSSEL=0x0 and EDGEDET=0x0 in LUTnCTRLA register).
4. In Standby sleep mode, only the RTC functionality requires the RUNSTDBY to be set to enter an active state. In Power-Down sleep mode, only the PIT functionality is available.
5. Start-of-Frame interrupt is only available in Standby sleep mode.
6. In Standby sleep mode, only the Start-of-Frame interrupt will trigger Wake-Up from USART.

12.3.2.2 Wake-up Time

The normal wake-up time for the device is six main clock cycles (CLK_PER), plus the time it takes to start the main clock source and the time it takes to start the regulator if it has been switched off:

- In Idle sleep mode, the main clock source is kept running to eliminate additional wake-up time

- In Standby sleep mode, the main clock might be running depending on the peripheral configuration
- In Power-Down sleep mode, only the internal 32.768 kHz oscillator and the Real-Time Clock (RTC) clock source may be running. These are used by the Brown-out Detector (BOD), Watchdog Timer (WDT) or Periodic Interrupt Timer (PIT). All the other clock sources will be OFF.

Table 12-4. Sleep Modes and Start-Up Time

Sleep Mode	Start-Up Time
Idle	Six clock cycles
Standby	Six clock cycles + one OSC start-up
Power-Down	Six clock cycles + one OSC start-up

The start-up time for the different clock sources is described in the *CLKCTRL - Clock Controller* section.

In addition to the normal wake-up time, it is possible to make the device wait until the BOD is ready before executing the code. This is done by writing 0×3 to the BOD operation mode in the Active and Idle (ACTIVE) bit field in the BOD Configuration (FUSE.BODCFG) fuse. If the BOD is ready before the normal wake-up time, the total wake-up time will be the same. If the BOD takes longer than the normal wake-up time, the wake-up time will be extended until the BOD is ready. This ensures correct supply voltage whenever code is executed.

12.3.3 Debug Operation

During run-time debugging, this peripheral will continue normal operation. The SLPCTRL is only affected by a break in the debug operation: If the SLPCTRL is in a sleep mode when a break occurs, the device will wake up, and the SLPCTRL will go to Active mode, even if there are no pending interrupt requests.

If the peripheral is configured to require periodic service by the CPU through interrupts or similar, improper operation or data loss may result during halted debugging.

12.4 Register Summary

Offset	Name	Bit Pos.	7	6	5	4	3	2	1	0
0x00	CTRLA	7:0						SMODE[1:0]		SEN

12.5 Register Description

12.5.1 Control A

Name: CTRLA
Offset: 0x00
Reset: 0x00
Property: -

	7	6	5	4	3	2	1	0
	SMODE[1:0]						SEN	
Access	R	R	R	R	R	R/W	R/W	R/W
Reset	0	0	0	0	0	0	0	0

Bits 2:1 – SMODE[1:0] Sleep Mode

Writing these bits selects which sleep mode to enter when the Sleep Enable (SEN) bit is written to '1' and the `SLEEP` instruction is executed.

Value	Name	Description
0x0	IDLE	Idle sleep mode enabled
0x1	STANDBY	Standby sleep mode enabled
0x2	PDOWN	Power-Down sleep mode enabled
other	-	Reserved

Bit 0 – SEN Sleep Enable

This bit must be written to '1' before the `SLEEP` instruction is executed to make the MCU enter the selected Sleep mode.

13. RSTCTRL - Reset Controller

13.1 Features

- Returns the Device to an Initial State after a Reset
- Identifies the Previous Reset Source
- Power Supply Reset Sources:
 - Power-on Reset (POR)
 - Brown-out Detector (BOD) Reset
- User Reset Sources:
 - External Reset (RESET)
 - Watchdog Timer (WDT) Reset
 - Software Reset (SWRST)
 - Unified Program and Debug Interface (UPDI) Reset

13.2 Overview

The Reset Controller (RSTCTRL) manages the Reset of the device. It issues a device Reset, sets the device to its initial state, and allows the Reset source to be identified by software.

13.2.1 Block Diagram

Figure 13-1. Reset System Overview

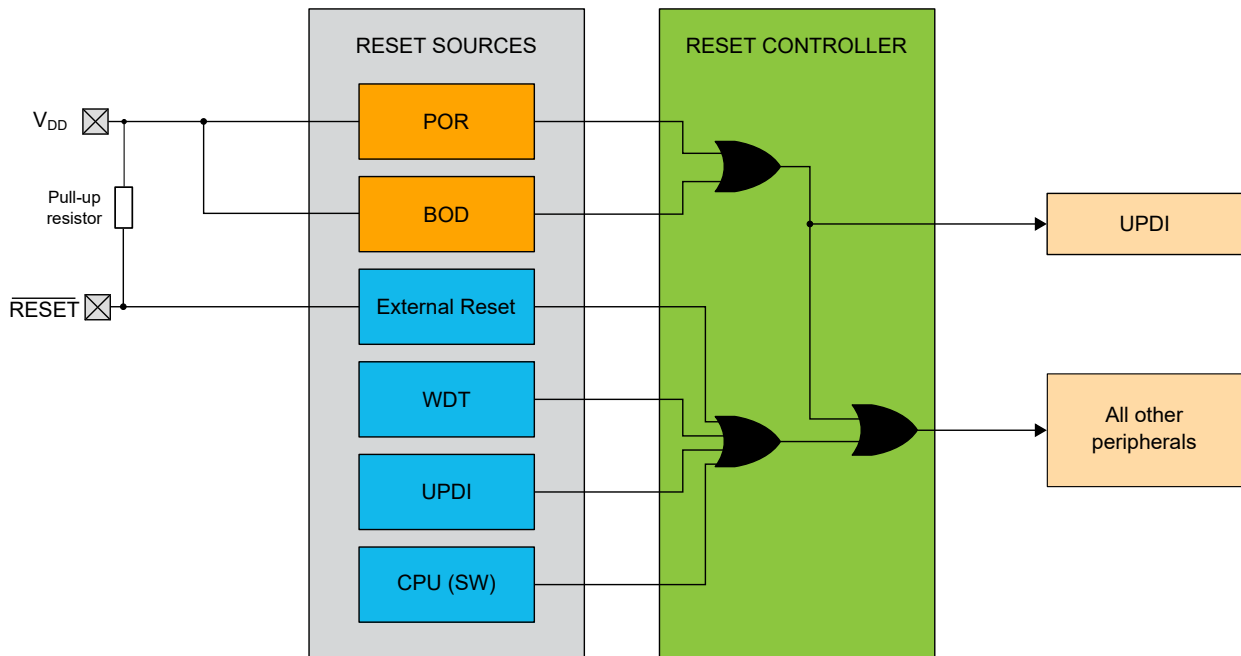

13.2.2 Signal Description

Signal	Description	Type
RESET	External Reset (active-low)	Digital input

13.3 Functional Description

13.3.1 Initialization

The RSTCTRL is always enabled, but some of the Reset sources must be enabled individually (either by Fuses or by software) before they can request a Reset.

After a Reset from any source, the registers in the device with automatic loading from the Fuses or from the Signature Row are updated.

13.3.2 Operation

13.3.2.1 Reset Sources

After any Reset, the source that caused the Reset is found in the Reset Flag (RSTCTRL.RSTFR) register. The user can identify the previous Reset source by reading this register in the software application.

There are two types of Resets based on the source:

- Power Supply Reset Sources:
 - Power-on Reset (POR)
 - Brown-out Detector (BOD) Reset
- User Reset Sources:
 - External Reset ($\overline{\text{RESET}}$)
 - Watchdog Timer (WDT) Reset
 - Software Reset (SWRST)
 - Unified Program and Debug Interface (UPDI) Reset

13.3.2.1.1 Power-on Reset (POR)

The purpose of the Power-on Reset (POR) is to ensure a safe start-up of logic and memories. It is generated by an on-chip detection circuit and is always enabled. The POR is activated when the V_{DD} rises and gives active reset as long as V_{DD} is below the POR threshold voltage (V_{POR+}). The reset will last until the Start-up and reset initialization sequence is finished. The Start-up Time (SUT) is determined by fuses. Reset is activated again, without any delay, when V_{DD} falls below the detection level (V_{POR-}).

Figure 13-2. MCU Start-Up, $\overline{\text{RESET}}$ Tied to V_{DD}

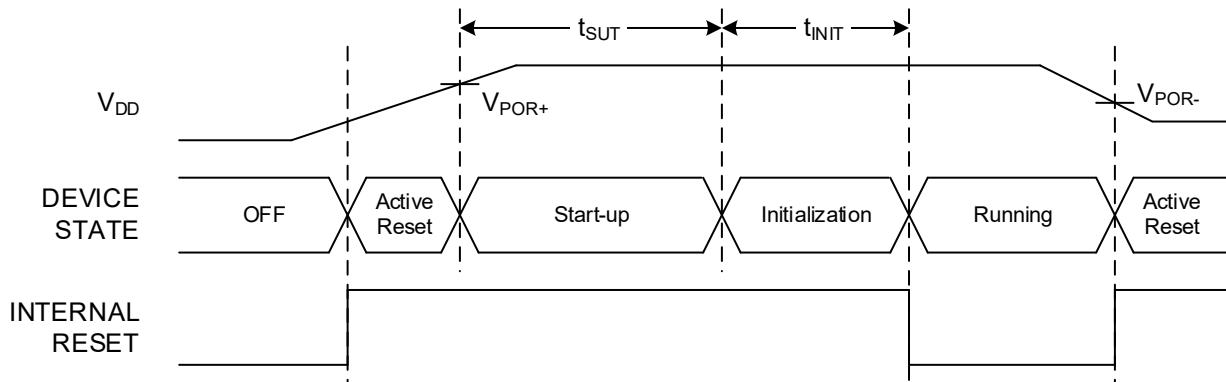

13.3.2.1.2 Brown-out Detector (BOD) Reset

The on-chip Brown-out Detector (BOD) circuit will monitor the V_{DD} level during operation by comparing it to a fixed trigger level. The trigger level for the BOD can be selected by fuses. If BOD is unused in the application, it is forced to a minimum level in order to ensure a safe operation during internal Reset and chip erase.

Figure 13-3. Brown-out Detector Reset

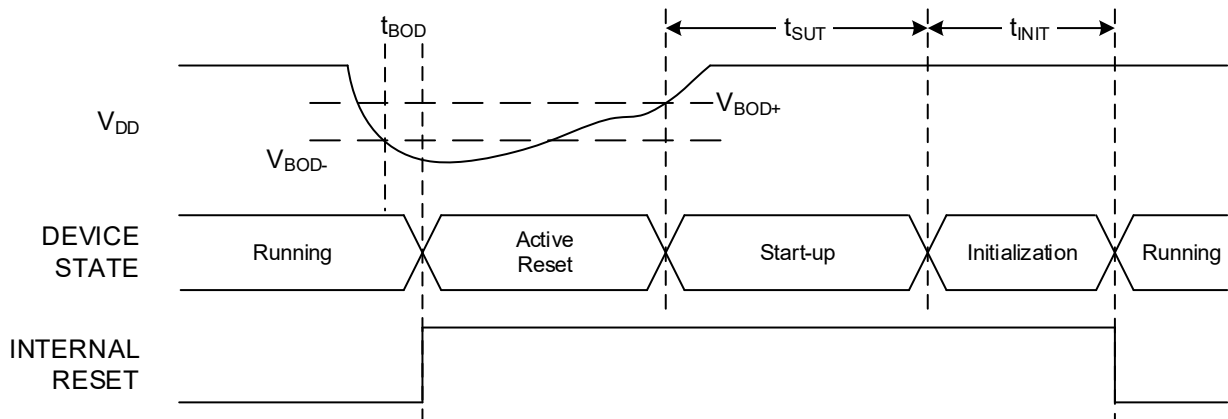

13.3.2.1.3 External Reset

The external Reset is enabled by a fuse, see the RSTPINCFG field in FUSE.SYSCFG0.

When enabled, the external Reset requests a Reset as long as the $\overline{\text{RESET}}$ pin is low. The device will stay in Reset until $\overline{\text{RESET}}$ is high again.

Figure 13-4. External Reset Characteristics

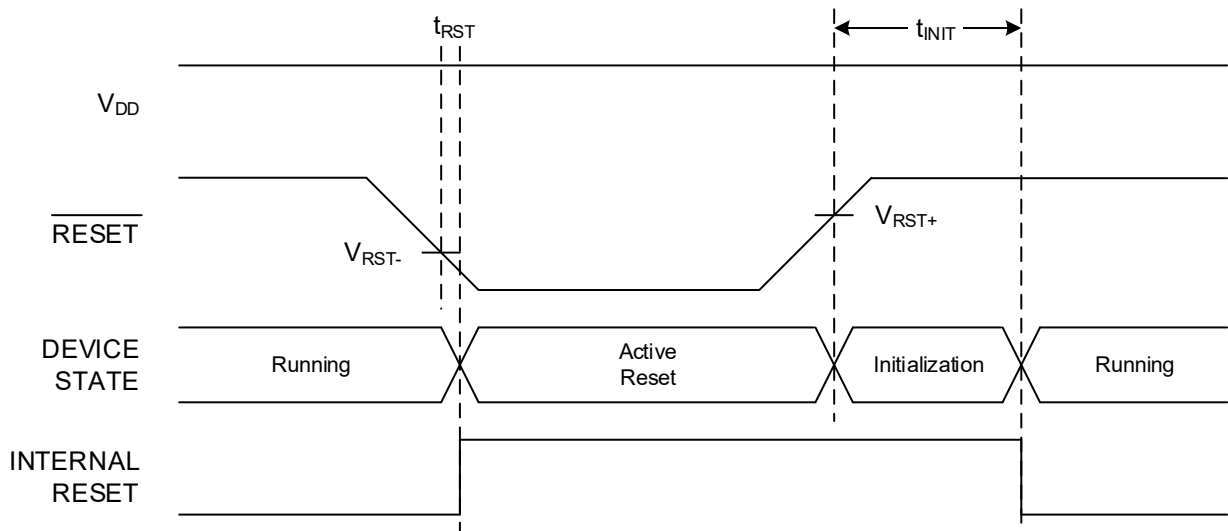

13.3.2.1.4 Watchdog Reset

The Watchdog Timer (WDT) is a system function for monitoring correct program operation. If the WDT is not reset from software according to the programmed time-out period, a Watchdog Reset will be issued. See the *WDT - Watchdog Timer* section for further details.

Figure 13-5. Watchdog Reset

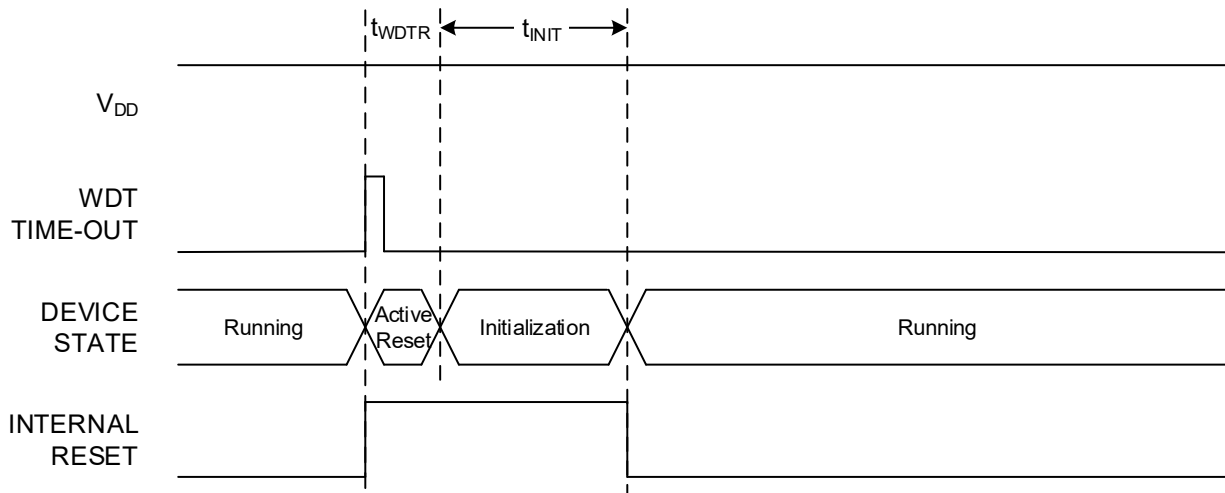

Note: The time t_{WDTR} is approximately 50 ns.

13.3.2.1.5 Software Reset

The software Reset makes it possible to issue a system Reset from software. The Reset is generated by writing a '1' to the Software Reset Enable (SWRE) bit in the Software Reset (RSTCTRL.SWRR) register.

The Reset will take place immediately after the bit is written, and the device will be kept in Reset until the Reset sequence is completed.

Figure 13-6. Software Reset

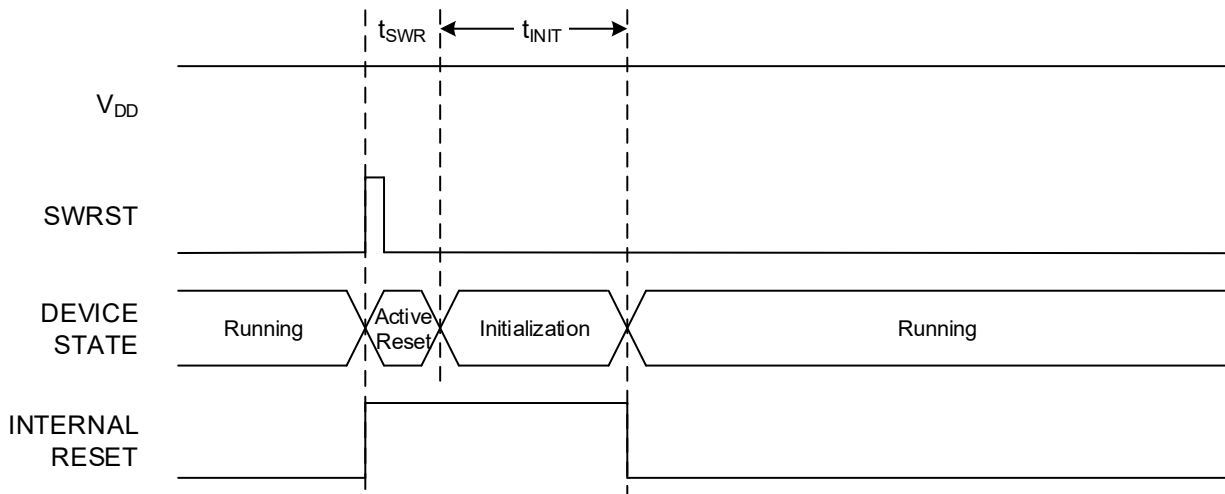

Note: The time t_{SWR} is approximately 50 ns.

13.3.2.1.6 Unified Program and Debug Interface (UPDI) Reset

The Unified Program and Debug Interface (UPDI) contains a separate Reset source used to reset the device during external programming and debugging. The Reset source is accessible only from external debuggers and programmers. More details can be found in the *UPDI - Unified Program and Debug Interface* section.

13.3.2.1.7 Domains Affected By Reset

The following logic domains are affected by the various Resets:

Table 13-1. Logic Domains Affected by Various Resets

Reset Type	Fuses are Reloaded	Reset of UPDI	Reset of Other Volatile Logic
POR	X	X	X
BOD	X	X	X
Software Reset	X		X
External Reset	X		X
Watchdog Reset	X		X
UPDI Reset	X		X

13.3.2.2 Reset Time

The Reset time can be split into two parts.

The first part is when any of the Reset sources are active. This part depends on the input to the Reset sources. The external Reset is active as long as the RESET pin is low. The Power-on Reset (POR) and the Brown-out Detector (BOD) are active as long as the supply voltage is below the Reset source threshold.

The second part is when all the Reset sources are released, and an internal Reset initialization of the device is done. This time will be increased with the start-up time given by the Start-Up Time Setting (SUT) bit field in the System Configuration 1 (FUSE.SYSCFG1) fuse when the reset is caused by a Power Supply Reset Source. The internal Reset initialization time will also increase if the Cyclic Redundancy Check Memory Scan (CRCSCAN) is configured to run at start-up. This configuration can be changed in the CRC Source (CRCSRC) bit field in the System Configuration 0 (FUSE.SYSCFG0) fuse.

13.3.3 Sleep Mode Operation

The RSTCTRL operates in Active mode and in all sleep modes.

13.3.4 Configuration Change Protection

This peripheral has registers that are under Configuration Change Protection (CCP). To write to these registers, a certain key must first be written to the CPU.CCP register, followed by a write access to the protected bits within four CPU instructions.

Attempting to write to a protected register without following the appropriate CCP unlock sequence leaves the protected register unchanged.

The following registers are under CCP:

Table 13-2. RSTCTRL - Registers Under Configuration Change Protection

Register	Key
RSTCTRL.SWRR	IOREG

13.4 Register Summary

Offset	Name	Bit Pos.	7	6	5	4	3	2	1	0
0x00	RSTFR	7:0			UPDIRF	SWRF	WDRF	EXTRF	BORF	PORF
0x01	SWRR	7:0								SWRE

13.5 Register Description

13.5.1 Reset Flag Register

Name: RSTFR
Offset: 0x00
Reset: 0xFF
Property: -

All flags are cleared by writing a '1' to them. They are also cleared by a Power-on Reset (POR), except for the Power-on Reset Flag (PORF).

	7	6	5	4	3	2	1	0
Access			UPDIRF	SWRF	WDRF	EXTRF	BORF	PORF
Reset			R/W	R/W	R/W	R/W	R/W	R/W
			x	x	x	x	x	x

Bit 5 – UPDIRF UPDI Reset Flag
 This bit is set if a UPDI Reset occurs.

Bit 4 – SWRF Software Reset Flag
 This bit is set if a Software Reset occurs.

Bit 3 – WDRF Watchdog Reset Flag
 This bit is set if a Watchdog Reset occurs.

Bit 2 – EXTRF External Reset Flag
 This bit is set if an External Reset occurs.

Bit 1 – BORF Brown-out Reset Flag
 This bit is set if a Brown-out Reset occurs.

Bit 0 – PORF Power-on Reset Flag
 This bit is set if a POR occurs.
 After a POR, only the POR flag is set and all the other flags are cleared. No other flags can be set before a full system boot is run after the POR.

13.5.2 Software Reset Register

Name: SWRR
Offset: 0x01
Reset: 0x00
Property: Configuration Change Protection

Bit	7	6	5	4	3	2	1	0
								SWRE
Access								R/W
Reset								0

Bit 0 – SWRE Software Reset Enable
When this bit is written to '1', a software Reset will occur.
This bit will always read as '0'.

14. CPUINT - CPU Interrupt Controller

14.1 Features

- Short and Predictable Interrupt Response Time
- Separate Interrupt Configuration and Vector Address for Each Interrupt
- Interrupt Prioritizing by Level and Vector Address
- Non-Maskable Interrupts (NMI) for Critical Functions
- Two Interrupt Priority Levels: 0 (Normal) and 1 (High):
 - One of the interrupt requests can optionally be assigned as a priority level 1 interrupt
 - Optional round robin priority scheme for priority level 0 interrupts
- Interrupt Vectors Optionally Placed in the Application Section or the Boot Loader Section
- Selectable Compact Vector Table (CVT)

14.2 Overview

An interrupt request signals a state change inside a peripheral and can be used to alter the program execution. The peripherals can have one or more interrupts. All interrupts are individually enabled and configured. When an interrupt is enabled and configured, it will generate an interrupt request when the interrupt condition occurs.

The CPU Interrupt Controller (CPUINT) handles and prioritizes the interrupt requests. When an interrupt is enabled and the interrupt condition occurs, the CPUINT will receive the interrupt request. Based on the interrupt's priority level and the priority level of any ongoing interrupt, the interrupt request is either acknowledged or kept pending until it has priority. After returning from the interrupt handler, the program execution continues from where it was before the interrupt occurred, and any pending interrupts are served after executing one instruction.

The CPUINT offers NMI for critical functions, one selectable high-priority interrupt, and an optional round robin scheduling scheme for normal-priority interrupts. The round robin scheduling ensures servicing all interrupts within a certain amount of time.

14.2.1 Block Diagram

Figure 14-1. CPUINT Block Diagram

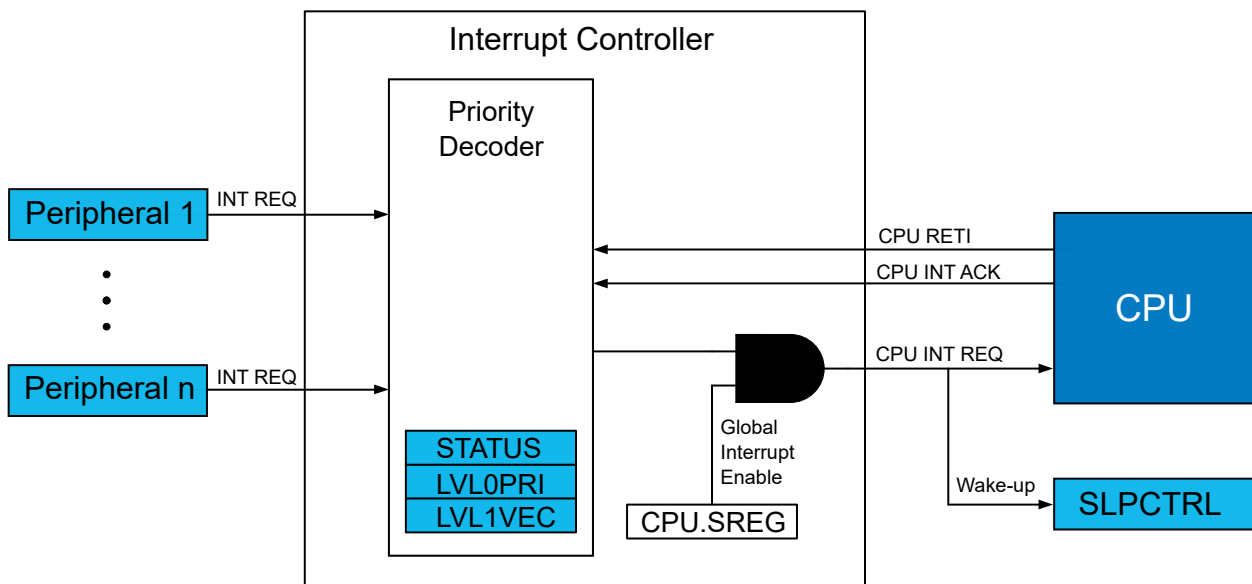

14.3 Functional Description

14.3.1 Initialization

Initialize an interrupt in the following order:

1. Optional: Configure the expected location of the interrupt vectors using the IVSEL bit in the Control A (CPUINT.CTRLA) register.
2. Optional: Enable compact vector table by writing '1' to the CVT bit in the Control A (CPUINT.CTRLA) register.
3. Optional: Enable vector prioritizing by round robin by writing a '1' to the Round Robin Priority Enable (LVL0RR) bit in CPUINT.CTRLA.
4. Optional: Select the Priority Level 1 vector by writing the interrupt vector number to the Interrupt Vector with Priority Level 1 (CPUINT.LVL1VEC) register.
5. Optional: Modify the priority of the LVL0 interrupts by configuring Interrupt Priority Level 0 (LVL0PRI) register.
6. Configure the interrupt conditions within each peripheral and enable the peripheral's interrupt.
7. Enable interrupts globally by writing a '1' to the Global Interrupt Enable (I) bit in the CPU Status (CPU.SREG) register.

14.3.2 Operation

14.3.2.1 Enabling, Disabling and Resetting

The global enabling of interrupts is done by writing a '1' to the Global Interrupt Enable (I) bit in the CPU Status (CPU.SREG) register. To disable interrupts globally, write a '0' to the I bit in CPU.SREG.

The desired interrupt lines must also be enabled in the respective peripheral by writing to the peripheral's Interrupt Control (*peripheral*.INTCTRL) register.

The interrupt flags are not automatically cleared after the interrupt is executed. The respective INTFLAGS register descriptions provide information on how to clear specific flags.

14.3.2.2 Interrupt Vector Locations

The expected location of interrupt vectors is dependent on the value of the Interrupt Vector Select (IVSEL) bit in the Control A (CPUINT.CTRLA) register. Refer to the IVSEL description in [CPUINT.CTRLA](#) for the possible locations.

If the program never enables an interrupt source, the interrupt vectors are not used, and the regular program code can be placed at these locations.

14.3.2.3 Interrupt Response Time

The minimum interrupt response time is represented in the following table.

Table 14-1. Minimum Interrupt Response Time

	Flash Size > 8 KB	Flash Size ≤ 8 KB
Finish ongoing instruction	One cycle	One cycle
Store PC to stack	Two cycles	Two cycles
Jump to interrupt handler	Three cycles (<i>jmp</i>)	Two cycles (<i>rjmp</i>)

After the Program Counter is pushed on the stack, the program vector for the interrupt is executed. See the following figure.

Figure 14-2. Interrupt Execution of Single-Cycle Instruction

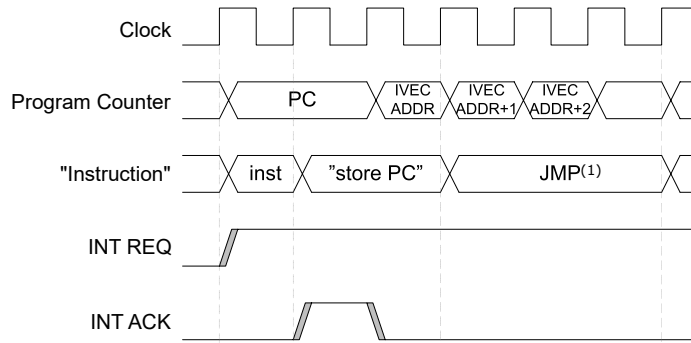

If an interrupt occurs during the execution of a multi-cycle instruction, the instruction is completed before the interrupt is served, as shown in the following figure.

Figure 14-3. Interrupt Execution of Multi-Cycle Instruction

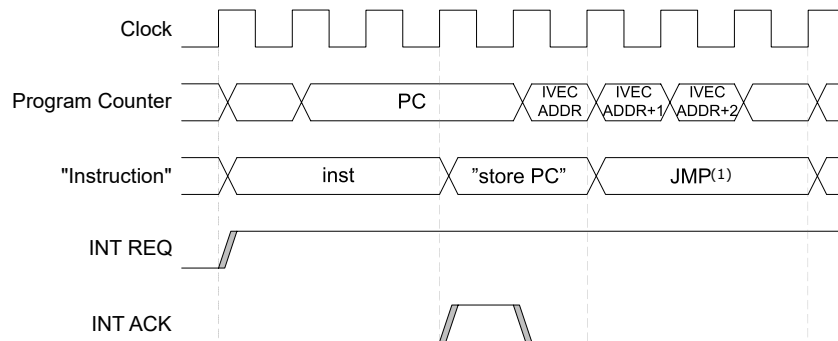

If an interrupt occurs when the device is in a sleep mode, the interrupt execution response time is increased by five clock cycles, as shown in the figure below. Also, the response time is increased by the start-up time from the selected sleep mode.

Figure 14-4. Interrupt Execution From Sleep

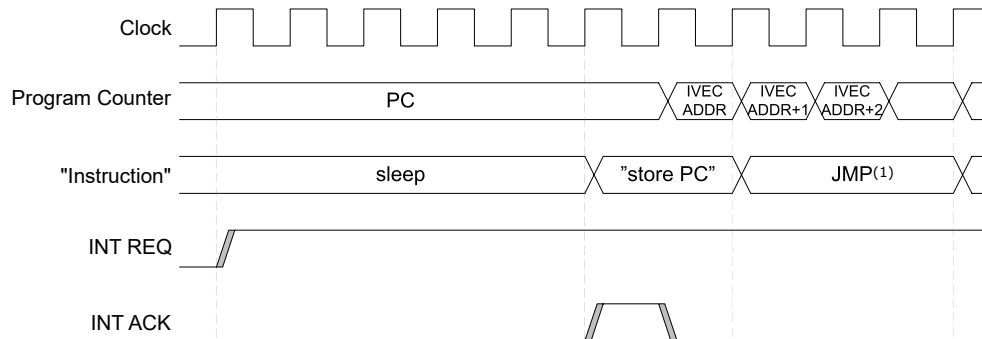

A return from an interrupt handling routine takes four to five clock cycles, depending on the size of the Program Counter. During these clock cycles, the Program Counter is popped from the stack, and the Stack Pointer is incremented.

Note:

1. Devices with 8 KB of Flash or less use `RJMP` instead of `JMP`, which takes only two clock cycles.

14.3.2.4 Interrupt Priority

All interrupt vectors are assigned to one of three possible priority levels, as shown in the table below. An interrupt request from a high-priority source will interrupt any ongoing interrupt handler from a normal-priority source. When returning from the high-priority interrupt handler, the execution of the normal-priority interrupt handler will resume.

Table 14-2. Interrupt Priority Levels

Priority	Level	Source
Highest	Non-Maskable Interrupt	Device-dependent and statically assigned
...	Level 1 (high priority)	One vector is optionally user selectable as level 1
Lowest	Level 0 (normal priority)	The remaining interrupt vectors

14.3.2.4.1 Non-Maskable Interrupts

A Non-Maskable Interrupt (NMI) will be executed regardless of the I bit setting in CPU.SREG. An NMI will never change the I bit. No other interrupt can interrupt an NMI handler. If more than one NMI is requested at the same time, the priority is static according to the interrupt vector address, where the lowest address has the highest priority.

Which interrupts are non-maskable is device-dependent and not subject to configuration. Non-maskable interrupts must be enabled before they can be used. Refer to the *Interrupt Vector Mapping* table of the device for available NMI sources.

14.3.2.4.2 High-Priority Interrupt

It is possible to assign one interrupt request to level 1 (high priority) by writing its interrupt vector number to the CPUINT.LVL1VEC register. This interrupt request will have a higher priority than the other (normal priority) interrupt requests. The priority level 1 interrupts will interrupt the level 0 interrupt handlers.

14.3.2.4.3 Normal-Priority Interrupts

All interrupt vectors other than NMI are assigned to priority level 0 (normal) by default. The user may override this by assigning one of these vectors as a high-priority vector. The device will have many normal-priority vectors, and some of these may be pending at the same time. Two different scheduling schemes are available to choose which of the pending normal-priority interrupts to service first: Static or round robin.

IVEC is the interrupt vector mapping, as listed in the *Peripherals and Architecture* section. The following sections use IVEC to explain the scheduling schemes. IVEC0 is the Reset vector, IVEC1 is the NMI vector, and so on. In a vector table with n+1 elements, the vector with the highest vector number is denoted IVECn. Reset, non-maskable interrupts, and high-level interrupts are included in the IVEC map, but will always be prioritized over the normal-priority interrupts.

Static Scheduling

If several level 0 interrupt requests are pending at the same time, the one with the highest priority is scheduled for execution first. The following figure illustrates the default configuration, where the interrupt vector with the lowest address has the highest priority.

Figure 14-5. Default Static Scheduling

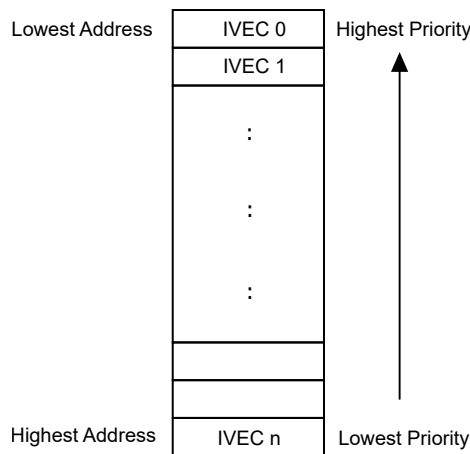

Modified Static Scheduling

The default priority can be changed by writing a vector number to the CPUINT.LVL0PRI register. This vector number will be assigned the lowest priority. The next interrupt vector in the IVEC will have the highest priority among the LVL0 interrupts, as shown in the following figure.

Figure 14-6. Static Scheduling When CPUINT.LVL0PRI Is Different from Zero

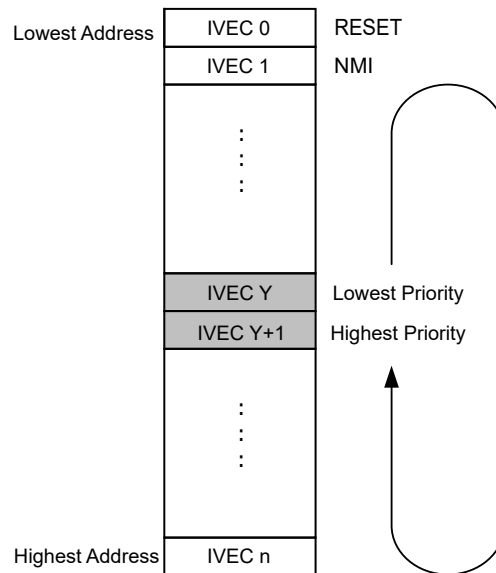

Here, value Y has been written to CPUINT.LVL0PRI so that the interrupt vector Y+1 has the highest priority. Note that, in this case, the priorities will wrap so that the lowest address no longer has the highest priority, not including RESET and NMI, which will always have the highest priority.

Refer to the interrupt vector mapping of the device for available interrupt requests and their interrupt vector number.

Round Robin Scheduling

The static scheduling may prevent some interrupt requests from being serviced. To avoid this, the CPUINT offers round robin scheduling for normal-priority (LVL0) interrupts. In the round robin scheduling, the CPUINT.LVL0PRI register stores the last acknowledged interrupt vector number. This register ensures that the last acknowledged interrupt vector gets the lowest priority and is automatically updated by the hardware. The following figure illustrates the priority order after acknowledging IVEC Y and after acknowledging IVEC Y+1.

Figure 14-7. Round Robin Scheduling

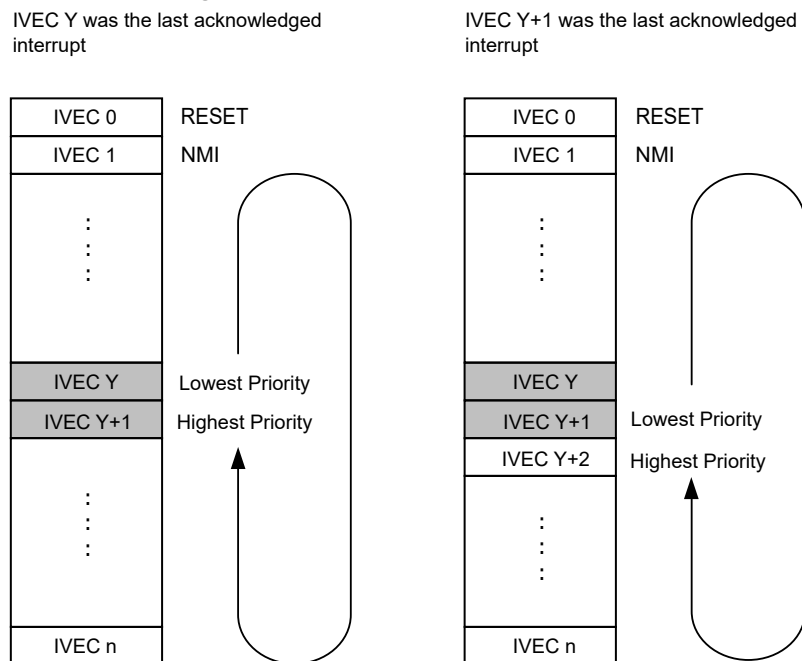

The round robin scheduling for LVL0 interrupt requests is enabled by writing a '1' to the Round Robin Priority Enable (LVL0RR) bit in the Control A (CPUINT.CTRLA) register.

14.3.2.5 Compact Vector Table

The Compact Vector Table (CVT) is a feature to allow the writing of compact code by having all level 0 interrupts share the same interrupt vector number. Thus, the interrupts share the same Interrupt Service Routine (ISR). This reduces the number of interrupt handlers and thereby frees up memory that can be used for the application code.

When CVT is enabled by writing a '1' to the CVT bit in the Control A (CPUINT.CTRLA) register, the vector table contains these three interrupt vectors:

1. The non-maskable interrupts (NMI) at vector address 1.
2. The Priority Level 1 (LVL1) interrupt at vector address 2.
3. All priority level 0 (LVL0) interrupts at vector address 3.

This feature is most suitable for devices with limited memory and applications using a few of interrupt generators.

14.3.3 Debug Operation

When using a level 1 priority interrupt, it is important to make sure the Interrupt Service Routine is configured correctly as it may cause the application to be stuck in an interrupt loop with level 1 priority.

By reading the CPUINT STATUS (CPUINT.STATUS) register, it is possible to see if the application has executed the correct `RETI` (interrupt return) instruction. The CPUINT.STATUS register contains state information, which ensures that the CPUINT returns to the correct interrupt level when the `RETI` instruction is executed at the end of an interrupt handler. Returning from an interrupt will return the CPUINT to the state it had before entering the interrupt.

14.3.4 Configuration Change Protection

This peripheral has registers that are under Configuration Change Protection (CCP). To write to these registers, a certain key must first be written to the CPU.CCP register, followed by a write access to the protected bits within four CPU instructions.

Attempting to write to a protected register without following the appropriate CCP unlock sequence leaves the protected register unchanged.

The following registers are under CCP:

Table 14-3. CPUINT - Registers Under Configuration Change Protection

Register	Key
The IVSEL and CVT bit fields in CPUINT.CTRLA	IOREG

14.4 Register Summary

Offset	Name	Bit Pos.	7	6	5	4	3	2	1	0
0x00	CTRLA	7:0		IVSEL	CVT					LVL0RR
0x01	STATUS	7:0	NMIEX						LVL1EX	LVL0EX
0x02	LVL0PRI	7:0	LVL0PRI[7:0]							
0x03	LVL1VEC	7:0	LVL1VEC[7:0]							

14.5 Register Description

14.5.1 Control A

Name: CTRLA
Offset: 0x00
Reset: 0x00
Property: Configuration Change Protection

	7	6	5	4	3	2	1	0
Access		IVSEL	CVT					LVL0RR
Reset		R/W	R/W					R/W
		0	0					0

Bit 6 – IVSEL Interrupt Vector Select

When the entire Flash is configured as a BOOT section, this bit will be ignored.

Value	Description
0	The expected location of the interrupt vectors is directly after the BOOT section ⁽¹⁾
1	The expected location of the interrupt vectors is at the start of the BOOT section

Note:

1. A system reset will cause the Program Counter to be reset to 0x0000, regardless of the IVSEL bit value.

Bit 5 – CVT Compact Vector Table

Value	Description
0	Compact Vector Table function is disabled
1	Compact Vector Table function is enabled

Bit 0 – LVL0RR Round Robin Priority Enable

This bit is not protected by the Configuration Change Protection mechanism.

Value	Description
0	Priority is fixed for priority level 0 interrupt requests: The lowest interrupt vector address has the highest priority.
1	The round robin priority scheme is enabled for priority level 0 interrupt requests

14.5.2 Status

Name: STATUS
Offset: 0x01
Reset: 0x00
Property: -

	7	6	5	4	3	2	1	0
	NMIEX						LVL1EX	LVL0EX
Access	R						R	R
Reset	0						0	0

Bit 7 – NMIEX Non-Maskable Interrupt Executing

This flag is set if a non-maskable interrupt is executing. The flag is cleared when returning (RETI) from the interrupt handler.

Bit 1 – LVL1EX Level 1 Interrupt Executing

This flag is set when a priority level 1 interrupt is executing, or when the interrupt handler has been interrupted by an NMI. The flag is cleared when returning (RETI) from the interrupt handler.

Bit 0 – LVL0EX Level 0 Interrupt Executing

This flag is set when a priority level 0 interrupt is executing, or when the interrupt handler has been interrupted by a priority level 1 interrupt or an NMI. The flag is cleared when returning (RETI) from the interrupt handler.

14.5.3 Interrupt Priority Level 0

Name: LVL0PRI
Offset: 0x02
Reset: 0x00
Property: -

Bit	7	6	5	4	3	2	1	0
	LVL0PRI[7:0]							
Access	R/W	R/W	R/W	R/W	R/W	R/W	R/W	R/W
Reset	0	0	0	0	0	0	0	0

Bits 7:0 – LVL0PRI[7:0] Interrupt Priority Level 0

This register is used to modify the priority of the LVL0 interrupts. See the section [Normal-Priority Interrupts](#) for more information.

14.5.4 Interrupt Vector with Priority Level 1

Name: LVL1VEC
Offset: 0x03
Reset: 0x00
Property: -

Bit	7	6	5	4	3	2	1	0
	LVL1VEC[7:0]							
Access	R/W	R/W	R/W	R/W	R/W	R/W	R/W	R/W
Reset	0	0	0	0	0	0	0	0

Bits 7:0 – LVL1VEC[7:0] Interrupt Vector with Priority Level 1

This bit field contains the number of the single vector with increased priority level 1 (LVL1). If this bit field has the value 0x00, no vector has LVL1. Consequently, the LVL1 interrupt is disabled.

15. EVSYS - Event System

15.1 Features

- System for Direct Peripheral-to-Peripheral Signaling
- Peripherals Can Directly Produce, Use, and React to Peripheral Events
- Short and Predictable Response Time
- Up to 6 Parallel Event Channels Available
- Each Channel Is Driven by One Event Generator and Can Have Multiple Event Users
- Events Can Be Sent and/or Received by Most Peripherals and by Software
- The Event System Works in Active, Idle, and Standby Sleep Modes

15.2 Overview

The Event System (EVSYS) enables direct peripheral-to-peripheral signaling. It allows a change in one peripheral (the event generator) to trigger actions in other peripherals (the event users) through event channels, without using the CPU. It is designed to provide a short and predictable response time between peripherals, allowing for autonomous peripheral control and interaction, and for synchronized timing of actions in several peripheral modules. Thus, the EVSYS peripheral makes it possible to implement Core Independent Peripherals (CIPs). Also, it is a powerful tool for reducing the complexity, size, and execution time of the software.

A change of the event generator's state is referred to as an event and usually corresponds to one of the peripheral's interrupt conditions. Events can be forwarded directly to other peripherals using the dedicated event routing network. The routing of each channel is configured in software, including event generation and use.

Only one event signal can be routed on each channel. Multiple peripherals can use events from the same channel.

The EVSYS can connect peripherals such as ADCs, analog comparators, I/O PORT pins, the real-time counter, timer/counters, and the configurable custom logic peripheral. Events can also be generated from software.

15.2.1 Block Diagram

Figure 15-1. EVSYS Block Diagram

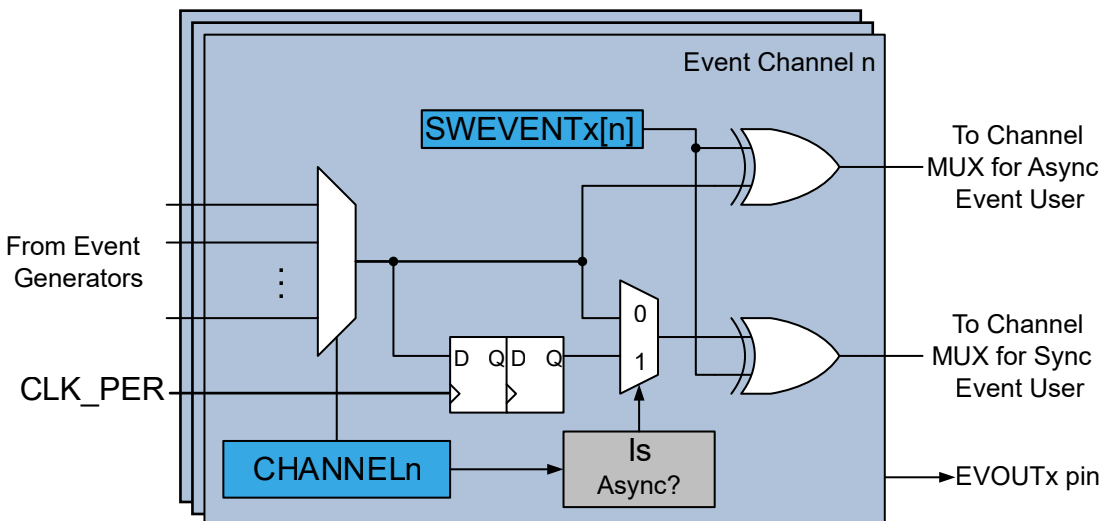

The block diagram shows the operation of an event channel. A multiplexer controlled by Channel n Generator Selection (EVSYS.CHANNELn) register at the input selects which of the event sources to route onto the event channel. Each event channel has two subchannels: one asynchronous and one synchronous. A synchronous user will listen to the synchronous subchannel, and an asynchronous user will listen to the asynchronous subchannel.

An event signal from an asynchronous source will be synchronized by the Event System before being routed to the synchronous subchannel. An asynchronous event signal to be used by a synchronous consumer must last for at least one peripheral clock cycle to ensure that it will propagate through the synchronizer. The synchronizer will delay such an event between two and three clock cycles, depending on when the event occurs.

Figure 15-2. Example of Event Source, Generator, User, and Action

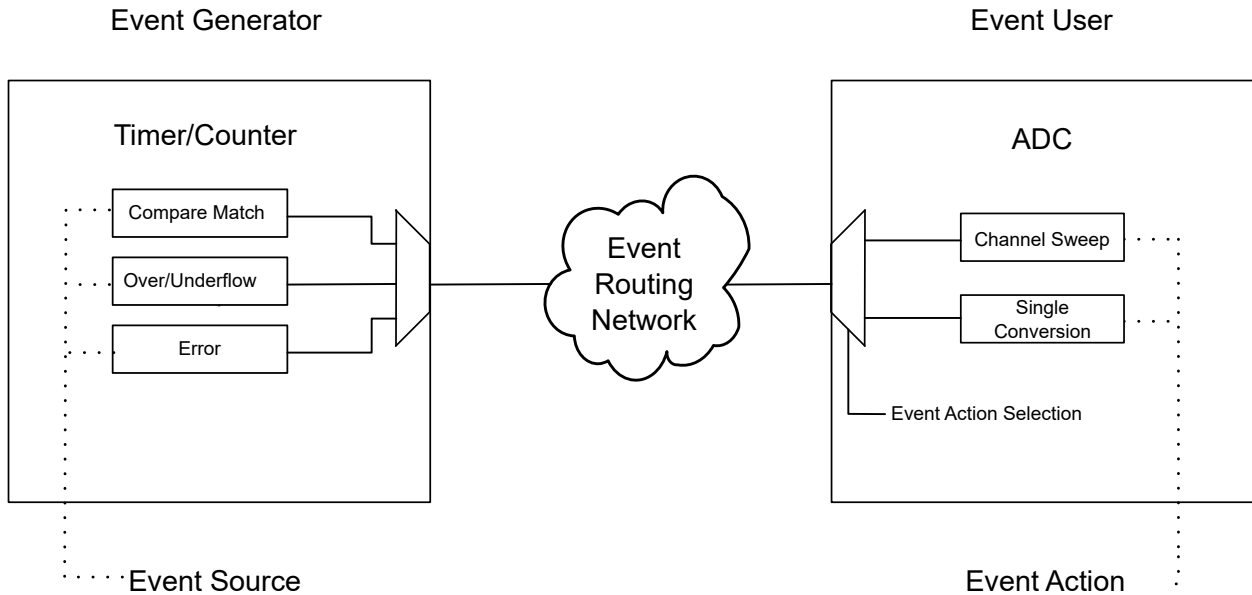

15.2.2 Signal Description

Signal	Type	Description
EVOUTx	Digital output	Event output, one output per I/O Port

15.3 Functional Description

15.3.1 Initialization

To utilize events, the Event System, the generating peripheral, and the peripheral(s) using the event must be set up accordingly:

1. Configure the generating peripheral appropriately. For example, if the generating peripheral is a timer, set the prescaling, the Compare register, etc., so that the desired event is generated.
2. Configure the event user peripheral(s) appropriately. For example, if the ADC is the event user, set the ADC prescaler, resolution, conversion time, etc., as desired, and configure the ADC conversion to start at the reception of an event.
3. Configure the Event System to route the desired source. In this case, the Timer/Compare match to the desired event channel. This may, for example, be Channel 0, which is accomplished by writing to the Channel 0 Generator Selection (EVSYS.CHANNEL0) register.
4. Configure the ADC to listen to this channel by writing to the corresponding User x Channel MUX (EVSYS.USERx) register.

15.3.2 Operation

15.3.2.1 Event User Multiplexer Setup

Each event user has one dedicated event user multiplexer selecting which event channel to listen to. The application configures these multiplexers by writing to the corresponding EVSYS.USERx register.

15.3.2.2 Event System Channel

An event channel can be connected to one of the event generators.

The source for each event channel is configured by writing to the respective Channel n Generator Selection (EVSYS.CHANNELn) register.

15.3.2.3 Event Generators

Each event channel has several possible event generators, but only one can be selected at a time. The event generator for a channel is selected by writing to the respective Channel n Generator Selection (EVSYS.CHANNELn) register. By default, the channels are not connected to any event generator. For details on event generation, refer to the documentation of the corresponding peripheral.

A generated event is either synchronous or asynchronous to the device peripheral clock (CLK_PER). Asynchronous events can be generated outside the normal edges of the peripheral clock, making the system respond faster than the selected clock frequency would suggest. Asynchronous events can also be generated while the device is in a sleep mode when the peripheral clock is not running.

Any generated event is classified as either a pulse event or a level event. In both cases, the event can be either synchronous or asynchronous, with properties according to the table below.

Table 15-1. Properties of Generated Events

Event Type	Sync/Async	Description
Pulse	Sync	An event generated from CLK_PER that lasts one clock cycle
	Async	An event generated from a clock other than CLK_PER lasting one clock cycle
Level	Sync	An event generated from CLK_PER that lasts multiple clock cycles
	Async	An event generated without a clock (for example, a pin or a comparator), or an event generated from a clock other than CLK_PER that lasts multiple clock cycles

The properties of both the generated event and the intended event user must be considered in order to ensure reliable and predictable operation.

The table below shows the available event generators for this device family.

Generator Name		Description	Event Type	Generating Clock Domain	Length of Event
Peripheral	Event				
UPDI	SYNCH	SYNCH character	Level	CLK_UPDI	SYNCH character on UPDI RX input synchronized to CLK_UPDI

ATtiny3224/3226/3227

EVSYS - Event System

.....continued						
Generator Name		Description	Event Type	Generating Clock Domain	Length of Event	
Peripheral	Event					
RTC	OVF	Overflow	Pulse	CLK_RTC	One CLK_RTC period	
	CMP	Compare Match				
	PIT_DIV8192	Prescaled RTC clock divided by 8192	Level			Given by prescaled RTC clock divided by 8192
	PIT_DIV4096	Prescaled RTC clock divided by 4096				Given by prescaled RTC clock divided by 4096
	PIT_DIV2048	Prescaled RTC clock divided by 2048				Given by prescaled RTC clock divided by 2048
	PIT_DIV1024	Prescaled RTC clock divided by 1024				Given by prescaled RTC clock divided by 1024
	PIT_DIV512	Prescaled RTC clock divided by 512				Given by prescaled RTC clock divided by 512
	PIT_DIV256	Prescaled RTC clock divided by 256				Given by prescaled RTC clock divided by 256
	PIT_DIV128	Prescaled RTC clock divided by 128				Given by prescaled RTC clock divided by 128
	PIT_DIV64	Prescaled RTC clock divided by 64				Given by prescaled RTC clock divided by 64
CCL	LUTn	LUT output level		Level		Asynchronous
ACn	OUT	Comparator output level	Level	Asynchronous	Given by AC output level	
ADCn	RES	Result ready	Pulse	CLK_PER	One CLK_PER period	
	SAMP	Sample ready				
	WCMP	Window compare match				
PORTx	PINn	Pin level	Level	Asynchronous	Given by pin level	
USARTn	XCK	USART Baud clock	Level	CLK_PER	Minimum two CLK_PER periods	
SPIn	SCK	SPI Host clock	Level	CLK_PER	Minimum two CLK_PER periods	

.....continued

Generator Name		Description	Event Type	Generating Clock Domain	Length of Event
Peripheral	Event				
TCA _n	OVF_LUNF	Normal mode: Overflow Split mode: Low Byte Timer underflow	Pulse	CLK_PER	One CLK_PER period
	HUNF	Normal mode: Not available Split mode: High Byte Timer underflow	Pulse	CLK_PER	One CLK_PER period
	CMP0_LCMP0	Normal mode: Compare Channel 0 match Split mode: Low Byte Timer Compare Channel 0 match	Pulse	CLK_PER	One CLK_PER period
	CMP1_LCMP1	Normal mode: Compare Channel 1 match Split mode: Low Byte Timer Compare Channel 1 match	Pulse	CLK_PER	One CLK_PER period
	CMP2_LCMP2	Normal mode: Compare Channel 2 match Split mode: Low byte timer Compare Channel 2 match	Pulse	CLK_PER	One CLK_PER period
TCB _n	CAPT	CAPT flag set	Pulse	CLK_PER	One CLK_PER period
	OVF	OVF flag set			

15.3.2.4 Event Users

The event channel to listen to is selected by configuring the event user. An event user may require the event signal to be either synchronous or asynchronous to the peripheral clock. An asynchronous event user can respond to events in sleep modes when clocks are not running. Such events can be responded to outside the normal edges of the peripheral clock, making the event user respond faster than the clock frequency would suggest. For details on the requirements of each peripheral, refer to the documentation of the corresponding peripheral.

Most event users implement edge or level detection to trigger actions in the corresponding peripheral based on the incoming event signal. In both cases, a user can either be synchronous, which requires that the incoming event is generated from the peripheral clock (CLK_PER), or asynchronous, if not. Some asynchronous event users do not apply event input detection but use the event signal directly. The different event user properties are described in general in the table below.

Table 15-2. Properties of Event Users

Input Detection	Async/Sync	Description
Edge	Sync	An event user is triggered by an event edge and requires that the incoming event is generated from CLK_PER
	Async	An event user is triggered by an event edge and has asynchronous detection or an internal synchronizer

.....continued

Input Detection	Async/Sync	Description
Level	Sync	An event user is triggered by an event level and requires that the incoming event is generated from CLK_PER
	Async	An event user is triggered by an event level and has asynchronous detection or an internal synchronizer
No detection	Async	An event user will use the event signal directly

The table below shows the available event users for this device family.

USER Name		Description	Input Detection	Async/Sync
Peripheral	Input			
CCL	LUTnx	LUTn input x or clock signal	Level	Async
ADCn	START	ADC start on event	Edge	Async
EVSYS	EVOUTx	Forward the event signal to pin	No detection	Async
USARTn	IRDA	IrDA mode input	Level	Sync
TCAn	CNTA	Count on positive event edge	Edge	Sync
		Count on any event edge	Edge	
		Count while event signal is high	Level	
		Event level controls count direction, up when low, and down when high	Level	
	CNTB	Event level controls count direction, up when low, and down when high	Level	Sync
		Restart counter on positive event edge	Edge	
		Restart counter on any event edge	Edge	
		Restart counter while event signal is high	Level	
TCBn	CAPT	Timeout check	Edge	Sync
		Input capture on event	Edge	
		Input capture frequency measurement	Edge	
		Input capture pulse-width measurement	Edge	
		Input capture frequency and pulse-width measurement	Edge	
		Single-shot	Edge	
	COUNT	Count on event	Edge	Sync

15.3.2.5 Synchronization

Events can be either synchronous or asynchronous to the peripheral clock. Each Event System channel has two subchannels: one asynchronous and one synchronous.

The asynchronous subchannel is identical to the event output from the generator. If the event generator generates a signal asynchronous to the peripheral clock, the signal on the asynchronous subchannel will be asynchronous. If the event generator generates a signal synchronous to the peripheral clock, the signal on the asynchronous subchannel will also be synchronous.

The synchronous subchannel is identical to the event output from the generator, if the event generator generates a signal synchronous to the peripheral clock. If the event generator generates a signal asynchronous to the peripheral

clock, this signal is first synchronized before being routed onto the synchronous subchannel. Depending on when it occurs, synchronization will delay the event by two to three clock cycles. The Event System automatically performs this synchronization if an asynchronous generator is selected for an event channel.

15.3.2.6 Software Event

The application can generate a software event. Software events on Channel n are issued by writing a '1' to the Software Event Channel Select (CHANNEL[n]) bit in the Software Events (EVSYS.SWEVENTx) register. A software event appears as a pulse on the Event System channel, inverting the current event signal for one clock cycle.

Event users see software events as no different from those produced by event generating peripherals.

15.3.3 Sleep Mode Operation

When configured, the Event System will work in all sleep modes. Software events represent one exception since they require a peripheral clock.

Asynchronous event users are able to respond to an event without their clock running in Standby sleep mode. Synchronous event users require their clock to be running to be able to respond to events. Such users will only work in Idle sleep mode or in Standby sleep mode, if configured to run in Standby mode by setting the RUNSTDBY bit in the appropriate register.

Asynchronous event generators are able to generate an event without their clock running, that is, in Standby sleep mode. Synchronous event generators require their clock to be running to be able to generate events. Such generators will only work in Idle sleep mode or in Standby sleep mode, if configured to run in Standby mode by setting the RUNSTDBY bit in the appropriate register.

15.3.4 Debug Operation

This peripheral is unaffected by entering Debug mode.

15.4 Register Summary

Offset	Name	Bit Pos.	7	6	5	4	3	2	1	0
0x00	SWEVENTA	7:0	SWEVENTA[7:0]							
0x01	Reserved									
...										
0x0F										
0x10		CHANNEL0	7:0	CHANNEL0[7:0]						
0x11	CHANNEL1	7:0	CHANNEL1[7:0]							
0x12	CHANNEL2	7:0	CHANNEL2[7:0]							
0x13	CHANNEL3	7:0	CHANNEL3[7:0]							
0x14	CHANNEL4	7:0	CHANNEL4[7:0]							
0x15	CHANNEL5	7:0	CHANNEL5[7:0]							
0x16	Reserved									
...										
0x1F										
0x20	USERCCLLUT0A	7:0	USER[7:0]							
...										
0x33	USERTCB1COUNT	7:0	USER[7:0]							

15.5 Register Description

15.5.1 Software Events

Name: SWEVENTx
Offset: 0x00
Reset: 0x00
Property: -

Write bits in this register to create a software event on the corresponding event channels.

Bits 0-7 in the EVSYS.SWEVENTA register correspond to event channels 0-7. If the number of available event channels is between eight and 15, these are available in the EVSYS.SWEVENTB register, where bit n corresponds to event channel 8+n.

Refer to the *Peripheral Overview* section for the available number of Event System channels.

Bit	7	6	5	4	3	2	1	0
	SWEVENTx[7:0]							
Access	W	W	W	W	W	W	W	W
Reset	0	0	0	0	0	0	0	0

Bits 7:0 – SWEVENTx[7:0] Software Event Channel Select

Writing a bit in this bit group to '1' will generate a single-pulse event on the corresponding event channel by inverting the signal on the event channel for one peripheral clock cycle.

15.5.2 Channel n Generator Selection

Name: CHANNELn
Offset: 0x10 + n*0x01 [n=0..5]
Reset: 0x00
Property: -

Each channel can be connected to one event generator. Not all generators can be connected to all channels. Refer to the table below to see which generator sources can be routed onto each channel and the generator value to be written to EVSYS.CHANNELn to achieve this routing. Writing the value 0x00 to EVSYS.CHANNELn turns the channel off.

Refer to the *Peripheral Overview* section for the available number of Event System channels.

	7	6	5	4	3	2	1	0
	CHANNELn[7:0]							
Access	R/W	R/W	R/W	R/W	R/W	R/W	R/W	R/W
Reset	0	0	0	0	0	0	0	0

Bits 7:0 – CHANNELn[7:0] Channel Generator Selection

The specific generator name corresponding to each bit group configuration is given by combining *Peripheral* and *Output* from the table below in the following way: PERIPHERAL_OUTPUT.

GENERATOR			Async/ Sync	Description	Channel Availability	
Value	Name					
	Peripheral	Output				
0x01	UPDI	SYNCH	Sync	Rising edge of SYNCH character detection	All channels	
0x06	RTC	OVF	Async	Counter overflow	All channels	
0x07		CMP		Compare match		
0x08		PIT_DIV8192		Prescaled RTC clock divided by 8192	Even numbered channels only	
0x09		PIT_DIV4096		Prescaled RTC clock divided by 4096		
0x0A		PIT_DIV2048		Prescaled RTC clock divided by 2048		
0x0B		PIT_DIV1024		Prescaled RTC clock divided by 1024		
0x08		PIT_DIV512		Prescaled RTC clock divided by 512		Odd numbered channels only
0x09		PIT_DIV256		Prescaled RTC clock divided by 256		
0x0A		PIT_DIV128		Prescaled RTC clock divided by 128		
0x0B		PIT_DIV64		Prescaled RTC clock divided by 64		
0x10	CCL	LUT0	Async	LUT output level	All channels	
0x11		LUT1				
0x12		LUT2				
0x13		LUT3				
0x20	AC0	OUT	Async	Comparator output level	All channels	
0x24	ADC0	RES	Sync	Result ready	All channels	
0x25		SAMP		Sample ready		
0x26		WCMP		Window compare match		

.....continued

GENERATOR			Async/ Sync	Description	Channel Availability
Value	Name				
	Peripheral	Output			
0x40-0x47	PORTA	PIN0-PIN7	Async	PORTA PIN0-PIN7 level ⁽²⁾	CHANNEL0 and CHANNEL1 only
0x48-0x4F					CHANNEL2 and CHANNEL3 only
0x40-0x47	PORTB	PIN0-PIN7	Async	PORTB PIN0-PIN7 level ⁽²⁾	CHANNEL4 and CHANNEL5 only
0x48-0x4F					CHANNEL0 and CHANNEL1 only
0x40-0x47	PORTC ⁽¹⁾	PIN0-PIN7	Async	PORTC PIN0-PIN7 level ⁽²⁾	CHANNEL2 and CHANNEL 3 only
0x48-0x4F					CHANNEL4 and CHANNEL5 only
0x60	USART0	XCK	Sync	Clock signal in SPI Host mode and synchronous USART Host mode	All channels
0x61	USART1	XCK			
0x68	SPI0	SCK	Sync	SPI host clock signal	All channels
0x80	TCA0	OVF_LUNF	Sync	Normal mode: Overflow	All channels
				Split mode: Low byte timer underflow	
0x81		HUNF	Sync	Normal mode: Not available	
				Split mode: High byte timer underflow	
0x84				CMP0_LCMP0	
	Split mode: Low byte timer Compare Channel 0 match				
0x85	CMP1_LCMP1	Sync	Normal mode: Compare Channel 1 match		
			Split mode: Low byte timer Compare Channel 1 match		
0x86	CMP2_LCMP2	Sync	Normal mode: Compare Channel 2 match		
			Split mode: Low byte timer Compare Channel 2 match		
0xA0	TCB0	CAPT	Sync	CAPT flag set ⁽³⁾	All channels
0xA1		OVF		OVF flag set	
0xA2	TCB1	CAPT	Sync	CAPT flag set ⁽³⁾	All channels
0xA3		OVF		OVF flag set	

Notes:

1. Not all peripheral instances are available for all pin counts. Refer to the Peripherals and Architecture section for details.
2. An event from the PORT pin will be zero if the input driver is disabled.
3. The operational mode of the timer decides when raising the CAPT flag. Refer to the TCB section for details.

15.5.3 User Channel MUX

Name: USER
Offset: 0x20 + n*0x01 [n=0..19]
Reset: 0x00
Property: -

Each event user can be connected to one channel and several users can be connected to the same channel. The following table lists all Event System users with their corresponding user ID number and name. The user name is given by combining USER with Peripheral and Input from the table below in the following way: USERPERIPHERALINPUT.

USER			Async/Sync	Description
#	Name	Input		
	Peripheral	Input		
0x00	CCL	LUT0A	Async	CCL LUT0 event input A
0x01		LUT0B		CCL LUT0 event input B
0x02		LUT1A		CCL LUT1 event input A
0x03		LUT1B		CCL LUT1 event input B
0x04		LUT2A		CCL LUT2 event input A
0x05		LUT2B		CCL LUT2 event input B
0x06		LUT3A		CCL LUT3 event input A
0x07		LUT3B		CCL LUT3 event input B
0x08	ADC0	START	Async	ADC start on event
0x09	EVSYS	EVOUTA	Async	EVSYS pin output A
0x0A		EVOUTB		EVSYS pin output B
0x0B		EVOUTC ⁽¹⁾		EVSYS pin output C
0x0C	USART0	IRDA	Sync	USART0 IrDA event input
0x0D	USART1	IRDA		USART1 IrDA event input
0x0E	TCA0	CNTA	Sync	Count on event or control count direction
0x0F		CNTB		Restart on event or control count direction
0x11	TCB0	CAPT	Both ⁽²⁾	Start, stop, capture, restart or clear counter
0x12		COUNT	Sync	Count on event
0x13	TCB1	CAPT	Both ⁽²⁾	Start, stop, capture, restart or clear counter
0x14		COUNT	Sync	Count on event

Notes:

1. Not all peripheral instances are available for all pin counts. Refer to the *Peripherals and Architecture* section for details.
2. Depends on the timer operational mode.

ATtiny3224/3226/3227

EVSYS - Event System

Bit	7	6	5	4	3	2	1	0
	USER[7:0]							
Access	R/W	R/W	R/W	R/W	R/W	R/W	R/W	R/W
Reset	0	0	0	0	0	0	0	0

Bits 7:0 – USER[7:0] User Channel Selection

Configures which Event System channel the user is connected to.

Value	Description
0	OFF, no channel is connected to this Event System user
n	The event user is connected to CHANNEL(n-1)

16. PORTMUX - Port Multiplexer

16.1 Overview

The Port Multiplexer (PORTMUX) can either enable or disable the functionality of the pins, or change between default and alternative pin positions. Available options are described in detail in the PORTMUX register map and depend on the actual pin and its properties.

For available pins and functionalities, refer to the *I/O Multiplexing and Considerations* section.

16.2 Register Summary

Offset	Name	Bit Pos.	7	6	5	4	3	2	1	0
0x00	EVSYSROUTEA	7:0							EVOUTB	EVOUTA
0x01	CCLROUTEA	7:0					LUT3	LUT2	LUT1	LUT0
0x02	USARTRROUTEA	7:0					USART1[1:0]		USART0[1:0]	
0x03	SPIROUTEA	7:0							SPI0[1:0]	
0x04	TCARROUTEA	7:0			TCA05	TCA04	TCA03	TCA02	TCA01	TCA00
0x05	TCBRROUTEA	7:0							TCB1	TCB0

16.3 Register Description

16.3.1 EVSYS Pin Position

Name: EVSYSROUTEA
Offset: 0x00
Reset: 0x00
Property: -

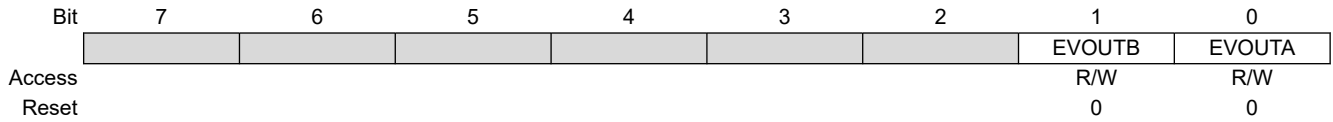

Bit 1 – EVOUTB Event Output B
 This bit controls the pin position for event output B.

Value	Name	Description
0x0	DEFAULT	EVOUT on PB2
0x1	ALT1	EVOUT on PB7

Bit 0 – EVOUTA Event Output A
 This bit controls the pin position for event output A.

Value	Name	Description
0x0	DEFAULT	EVOUT on PA2
0x1	ALT1	EVOUT on PA7

16.3.2 CCL Pin Position

Name: CCLROUTEA
Offset: 0x01
Reset: 0x00
Property: -

	7	6	5	4	3	2	1	0
					LUT3	LUT2	LUT1	LUT0
Access					R/W	R/W	R/W	R/W
Reset					0	0	0	0

Bit 3 – LUT3 CCL LUT 3 Signals

This bit field controls the pin locations for CCL LUT 3 signals.

Value	Name	Description			
		OUT	IN0	IN1	IN2
0x0	DEFAULT	PC4	PC0	PC1	PC2
0x1	ALT1	PA5	PC0	PC1	PC2

Bit 2 – LUT2 CCL LUT 2 Signals

This bit field controls the pin locations for CCL LUT 2 signals.

Value	Name	Description			
		OUT	IN0	IN1	IN2
0x0	DEFAULT	PB3	PB0	PB1	PB2
0x1	ALT1	PB6	PB0	PB1	PB2

Bit 1 – LUT1 CCL LUT 1 Signals

This bit field controls the pin locations for CCL LUT 1 signals.

Value	Name	Description			
		OUT	IN0	IN1	IN2
0x0	DEFAULT	PA7	PC3	PC4	PC5
0x1	ALT1	PC1	PC3	PC4	PC5

Bit 0 – LUT0 CCL LUT 0 Signals

This bit field controls the pin locations for CCL LUT 0 signals.

Value	Name	Description			
		OUT	IN0	IN1	IN2
0x0	DEFAULT	PA4	PA0	PA1	PA2
0x1	ALT1	PB4	PA0	PA1	PA2

16.3.3 USART Pin Position

Name: USARTROUTEA
Offset: 0x02
Reset: 0x00
Property: -

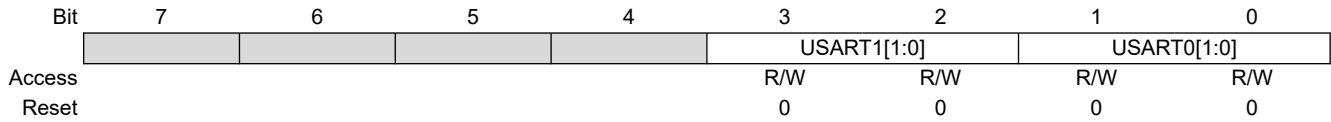

Bits 3:2 – USART1[1:0] USART 1 Signals
 This bit field controls the pin locations for USART 1 signals.

Value	Name	Description			
		TxD	RxD	XCK	XDIR
0x0	DEFAULT	PA1	PA2	PA3	PA4
0x1	ALT1	PC2	PC1	PC0	PC3
0x2	-	Reserved			
0x3	NONE	Not connected to any pins			

Bits 1:0 – USART0[1:0] USART 0 Signals
 This bit field controls the pin locations for USART 0 signals.

Value	Name	Description			
		TxD	RxD	XCK	XDIR
0x0	DEFAULT	PB2	PB3	PB1	PB0
0x1	ALT1	PA1	PA2	PA3	PA4
0x2	-	Reserved			
0x3	NONE	Not connected to any pins			

16.3.4 SPI Pin Positions

Name: SPIROUTEA
Offset: 0x03
Reset: 0x00
Property: -

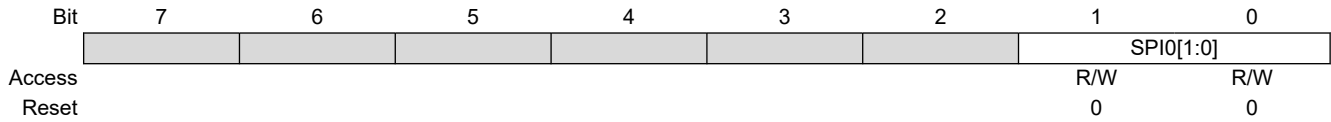

Bits 1:0 – SPI0[1:0] SPI 0 Signals
 This bit field controls the pin positions for SPI 0 signals.

Value	Name	Description			
		MOSI	MISO	SCK	\overline{SS}
0x0	DEFAULT	PA1	PA2	PA3	PA4
0x1	ALT1	PC2	PC1	PC0	PC3
0x2	-	Reserved			
0x3	NONE	Not connected to any pins			

16.3.5 TCA Pin Positions

Name: TCAROUTEA
Offset: 0x04
Reset: 0x00
Property: -

	7	6	5	4	3	2	1	0
Bit			TCA05	TCA04	TCA03	TCA02	TCA01	TCA00
Access			R/W	R/W	R/W	R/W	R/W	R/W
Reset			0	0	0	0	0	0

Bits 0, 1, 2, 3, 4, 5 – TCA0 TCA0 Signals
 This bit field controls the pin positions for TCA0 signals.

Value	Name	Description					
		WO0 on	WO1 on	WO2 on	WO3 on	WO4 on	WO5 on
0x0	DEFAULT	PB0	PB1	PB2	PA3	PA4	PA5
0x1	ALT1	PB3	PB4	PB5	PC3	PC4	PC5

16.3.6 TCB Pin Position

Name: TCBROUTEA
Offset: 0x05
Reset: 0x00
Property: -

	7	6	5	4	3	2	1	0
Access							TCB1	TCB0
Reset							R/W	R/W
							0	0

Bit 1 – TCB1 TCB1 Output

This bit controls the pin positions for TCB1 output.

Value	Name	Description
0x0	DEFAULT	WO on PA3
0x1	ALT1	WO on PC4

Bit 0 – TCB0 TCB0 Output

This bit controls the pin positions for TCB0 output.

Value	Name	Description
0x0	DEFAULT	WO on PA5
0x1	ALT1	WO on PC0

17. PORT - I/O Pin Configuration

17.1 Features

- General Purpose Input and Output Pins with Individual Configuration:
 - Pull-up
 - Inverted I/O
- Interrupts and Events:
 - Sense both edges
 - Sense rising edges
 - Sense falling edges
 - Sense low level
- Optional Slew Rate Control per I/O Port
- Asynchronous Pin Change Sensing that Can Wake the Device From all Sleep Modes
- Efficient and Safe Access to Port Pins
 - Hardware Read-Modify-Write (RMW) through dedicated toggle/clear/set registers
 - Mapping of often-used PORT registers into bit-accessible I/O memory space (virtual ports)

17.2 Overview

The I/O pins of the device are controlled by instances of the PORT peripheral registers. Each PORT instance has up to eight I/O pins. The PORTs are named PORTA, PORTB, PORTC, etc. Refer to the *I/O Multiplexing and Considerations* section to see which pins are controlled by what instance of PORT. The base addresses of the PORT instances and the corresponding Virtual PORT instances are listed in the *Peripherals and Architecture* section.

Each PORT pin has a corresponding bit in the Data Direction (PORTx.DIR) and Data Output Value (PORTx.OUT) registers to enable that pin as an output and to define the output state. For example, pin PA3 is controlled by DIR[3] and OUT[3] of the PORTA instance.

The input value of a PORT pin is synchronized to the Peripheral Clock (CLK_PER) and then made accessible as the data input value (PORTx.IN). The value of the pin can be read whether the pin is configured as input or output.

The PORT also supports asynchronous input sensing with interrupts and events for selectable pin change conditions. Asynchronous pin change sensing means that a pin change can trigger an interrupt and wake the device from sleep, including sleep modes where CLK_PER is stopped.

All pin functions are individually configurable per pin. The pins have hardware Read-Modify-Write functionality for a safe and correct change of the drive values and/or input and sense configuration.

The PORT pin configuration controls input and output selection of other device functions.

17.2.1 Block Diagram

Figure 17-1. PORT Block Diagram

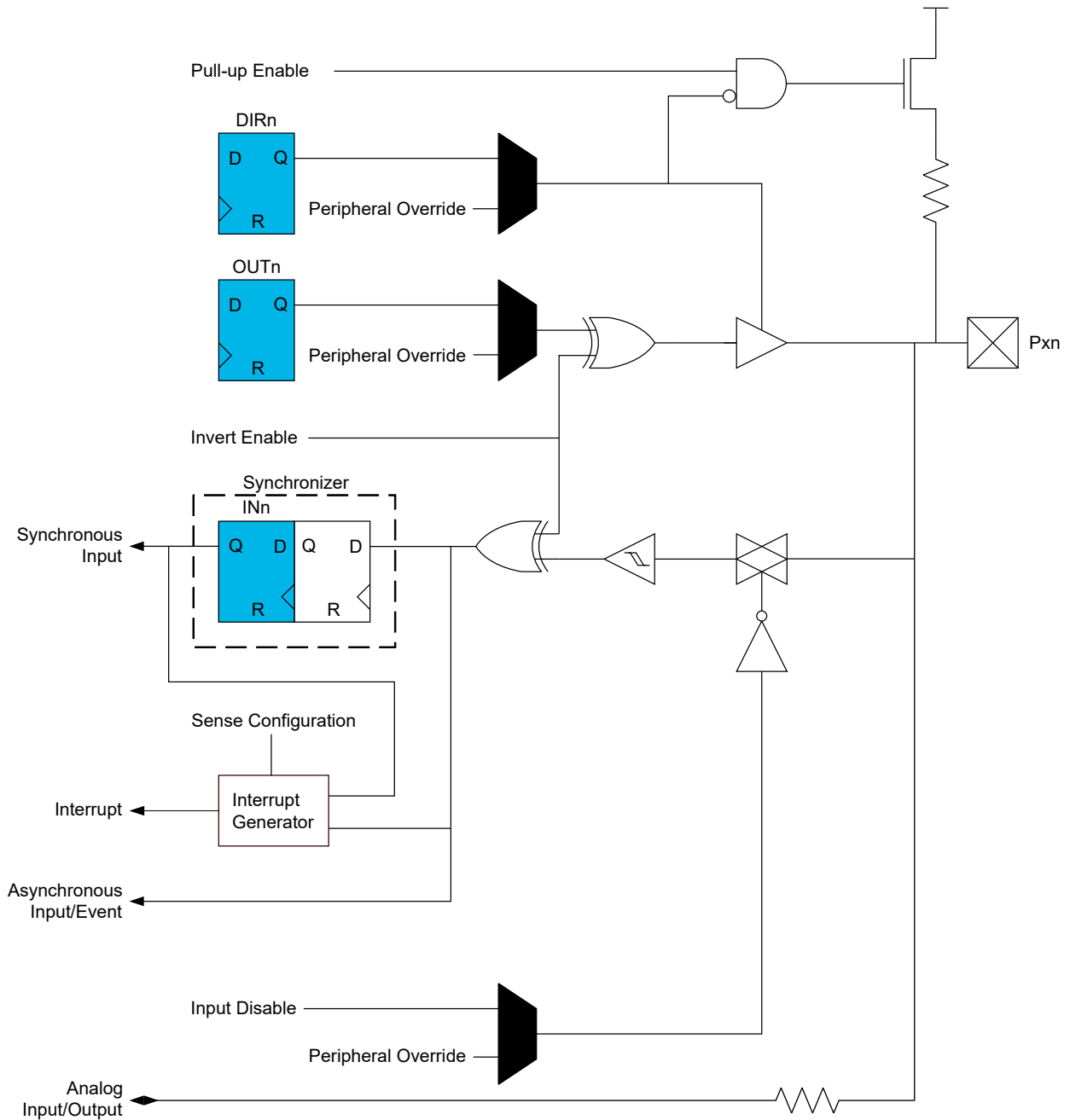

17.2.2 Signal Description

Signal	Type	Description
Pxn	I/O pin	I/O pin n on PORTx

17.3 Functional Description

17.3.1 Initialization

After Reset, all outputs are tri-stated, and digital input buffers enabled even if there is no clock running.

The following steps are all optional when initializing PORT operation:

- Enable or disable the output driver for pin P_{xn} by respectively writing '1' to bit n in the PORTx.DIRSET or PORTx.DIRCLR register
- Set the output driver for pin P_{xn} to high or low level respectively by writing '1' to bit n in the PORTx.OUTSET or PORTx.OUTCLR register
- Read the input of pin P_{xn} by reading bit n in the PORTx.IN register
- Configure the individual pin configurations and interrupt control for pin P_{xn} in PORTx.PINnCTRL



Important: For lowest power consumption, disable the digital input buffer of unused pins and pins that are used as analog inputs or outputs.

Specific pins, such as those used to connect a debugger, may be configured differently, as required by their special function.

17.3.2 Operation

17.3.2.1 Basic Functions

Each pin group x has its own set of PORT registers. I/O pin P_{xn} can be controlled by the registers in PORTx.

To use pin number n as an output, write bit n of the PORTx.DIR register to '1'. This can be done by writing bit n in the PORTx.DIRSET register to '1', which will avoid disturbing the configuration of other pins in that group. The nth bit in the PORTx.OUT register must be written to the desired output value.

Similarly, writing a PORTx.OUTSET bit to '1' will set the corresponding bit in the PORTx.OUT register to '1'. Writing a bit in PORTx.OUTCLR to '1' will clear that bit in PORTx.OUT to '0'. Writing a bit in PORTx.OUTTGL or PORTx.IN to '1' will toggle that bit in PORTx.OUT.

To use pin n as an input, bit n in the PORTx.DIR register must be written to '0' to disable the output driver. This can be done by writing bit n in the PORTx.DIRCLR register to '1', which will avoid disturbing the configuration of other pins in that group. The input value can be read from bit n in the PORTx.IN register as long as the ISC bit is not set to INPUT_DISABLE.

Writing a bit to '1' in PORTx.DIRTGL will toggle that bit in PORTx.DIR and toggle the direction of the corresponding pin.

17.3.2.2 Port Configuration

The Port Control (PORTx.PORTCTRL) register is used to configure the slew rate limitation for all the PORTx pins.

The slew rate limitation is enabled by writing a '1' to the Slew Rate Limit Enable (SLR) bit in PORTx.PORTCTRL. Refer to the *Electrical Characteristics* section for further details.

17.3.2.3 Pin Configuration

The Pin n Control (PORTx.PINnCTRL) register is used to configure inverted I/O, pull-up, and input sensing of a pin. The control register for pin n is at the byte address PORTx + 0x10 + n.

All input and output on the respective pin n can be inverted by writing a '1' to the Inverted I/O Enable (INVEN) bit in PORTx.PINnCTRL. When INVEN is '1', the PORTx.IN/OUT/OUTSET/OUTTGL registers will have an inverted operation for this pin.

Toggling the INVEN bit causes an edge on the pin, which can be detected by all peripherals using this pin, and is seen by interrupts or events if enabled.

The input pull-up of pin *n* is enabled by writing a '1' to the Pull-up Enable (PULLUPEN) bit in PORTx.PINnCTRL. The pull-up is disconnected when the pin is configured as an output, even if PULLUPEN is '1'.

Pin interrupts can be enabled for pin *n* by writing to the Input/Sense Configuration (ISC) bit field in PORTx.PINnCTRL. Refer to [17.3.3. Interrupts](#) for further details.

The digital input buffer for pin *n* can be disabled by writing the INPUT_DISABLE setting to ISC. This can reduce power consumption and may reduce noise if the pin is used as analog input. While configured to INPUT_DISABLE, bit *n* in PORTx.IN will not change since the input synchronizer is disabled.

17.3.2.4 Virtual Ports

The Virtual PORT registers map the most frequently used regular PORT registers into the I/O Register space with single-cycle bit access. Access to the Virtual PORT registers has the same outcome as access to the regular registers but allows for memory specific instructions, such as bit manipulation instructions, which cannot be used in the extended I/O Register space where the regular PORT registers reside. The following table shows the mapping between the PORT and VPORT registers.

Table 17-1. Virtual Port Mapping

Regular PORT Register	Mapped to Virtual PORT Register
PORTx.DIR	VPORTx.DIR
PORTx.OUT	VPORTx.OUT
PORTx.IN	VPORTx.IN
PORTx.INTFLAGS	VPORTx.INTFLAGS

17.3.2.5 Peripheral Override

Peripherals such as USARTs, ADCs and timers may be connected to I/O pins. Such peripherals will usually have a primary and, optionally, one or more alternate I/O pin connections, selectable by PORTMUX or a multiplexer inside the peripheral. By configuring and enabling such peripherals, the general purpose I/O pin behavior normally controlled by PORT will be overridden in a peripheral dependent way. Some peripherals may not override all the PORT registers, leaving the PORT module to control some aspects of the I/O pin operation.

Refer to the description of each peripheral for information on the peripheral override. Any pin in a PORT that is not overridden by a peripheral will continue to operate as a general purpose I/O pin.

17.3.3 Interrupts

Table 17-2. Available Interrupt Vectors and Sources

Name	Vector Description	Conditions
PORTx	PORT interrupt	INTn in PORTx.INTFLAGS is raised as configured by the Input/Sense Configuration (ISC) bit in PORTx.PINnCTRL

Each PORT pin *n* can be configured as an interrupt source. Each interrupt can be individually enabled or disabled by writing to ISC in PORTx.PINnCTRL.

When an interrupt condition occurs, the corresponding interrupt flag is set in the Interrupt Flags register of the peripheral (*peripheral*.INTFLAGS).

An interrupt request is generated when the corresponding interrupt source is enabled, and the interrupt flag is set. The interrupt request remains active until the interrupt flag is cleared. See the peripheral's INTFLAGS register for details on how to clear interrupt flags.

When setting or changing interrupt settings, take these points into account:

- If an Inverted I/O Enable (INVEN) bit is toggled in the same cycle as ISC is changed, the edge caused by the inversion toggling may not cause an interrupt request
- If an input is disabled by writing to ISC while synchronizing an interrupt, that interrupt may be requested on re-enabling the input, even if it is re-enabled with a different interrupt setting

- If the interrupt setting is changed by writing to ISC while synchronizing an interrupt, that interrupt may not be requested

17.3.3.1 Asynchronous Sensing Pin Properties

All PORT pins support asynchronous input sensing with interrupts for selectable pin change conditions. Fully asynchronous pin change sensing can trigger an interrupt and wake the device from all sleep modes, including modes where the Peripheral Clock (CLK_PER) is stopped, while partially asynchronous pin change sensing is limited as per the table below. See the *I/O Multiplexing and Considerations* section for further details on which pins support fully asynchronous pin change sensing.

Table 17-3. Behavior Comparison of Sense Pins

Property	Partially Asynchronous Pins	Fully Asynchronous Pins
Waking the device from sleep modes with CLK_PER running	From all interrupt sense configurations	From all interrupt sense configurations
Waking the device from sleep modes with CLK_PER stopped	Only from BOTHEDGES or LEVEL interrupt sense configurations	
Minimum pulse-width to trigger an interrupt with CLK_PER running	Minimum one CLK_PER cycle	Less than one CLK_PER cycle
Minimum pulse-width to trigger an interrupt with CLK_PER stopped	The pin value must be kept until CLK_PER has restarted ⁽¹⁾	
Interrupt “dead-time”	No new interrupt for three CLK_PER cycles after the previous	

Note:

1. If a partially asynchronous input pin is used for wake-up from sleep with CLK_PER stopped, the required level must be held long enough for the MCU to complete the wake-up to trigger the interrupt. If the level disappears, the MCU can wake up without any interrupt generated.

17.3.4 Events

PORT can generate the following events:

Table 17-4. Event Generators in PORTx

Generator Name		Description	Event Type	Generating Clock Domain	Length of Event
Peripheral	Event				
PORTx	PINn	Pin level	Level	Asynchronous	Given by pin level

All PORT pins are asynchronous event system generators. PORT has as many event generators as there are PORT pins in the device. Each event system output from PORT is the value present on the corresponding pin if the digital input buffer is enabled. If a pin input buffer is disabled, the corresponding event system output is zero.

PORT has no event inputs. Refer to the *Event System (EVSYS)* section for more details regarding event types and Event System configuration.

17.3.5 Sleep Mode Operation

Except for interrupts and input synchronization, all pin configurations are independent of sleep modes. All pins can wake the device from sleep, see the PORT Interrupt section for further details.

Peripherals connected to the PORTs can be affected by sleep modes, described in the respective peripherals' data sheet section.



Important: The PORTs will always use the Peripheral Clock (CLK_PER). Input synchronization will halt when this clock stops.

17.3.6 Debug Operation

When the CPU is halted in Debug mode, the PORT continues normal operation. If the PORT is configured in a way that requires it to be periodically serviced by the CPU through interrupts or similar, improper operation or data loss may result during debugging.

17.4 Register Summary - PORTx

Offset	Name	Bit Pos.	7	6	5	4	3	2	1	0
0x00	DIR	7:0	DIR[7:0]							
0x01	DIRSET	7:0	DIRSET[7:0]							
0x02	DIRCLR	7:0	DIRCLR[7:0]							
0x03	DIRTGL	7:0	DIRTGL[7:0]							
0x04	OUT	7:0	OUT[7:0]							
0x05	OUTSET	7:0	OUTSET[7:0]							
0x06	OUTCLR	7:0	OUTCLR[7:0]							
0x07	OUTTGL	7:0	OUTTGL[7:0]							
0x08	IN	7:0	IN[7:0]							
0x09	INTFLAGS	7:0	INT[7:0]							
0x0A	PORTCTRL	7:0								SRL
0x0B	Reserved									
...										
0x0F										
0x10	PIN0CTRL	7:0	INVEN				PULLUPEN	ISC[2:0]		
0x11	PIN1CTRL	7:0	INVEN				PULLUPEN	ISC[2:0]		
0x12	PIN2CTRL	7:0	INVEN				PULLUPEN	ISC[2:0]		
0x13	PIN3CTRL	7:0	INVEN				PULLUPEN	ISC[2:0]		
0x14	PIN4CTRL	7:0	INVEN				PULLUPEN	ISC[2:0]		
0x15	PIN5CTRL	7:0	INVEN				PULLUPEN	ISC[2:0]		
0x16	PIN6CTRL	7:0	INVEN				PULLUPEN	ISC[2:0]		
0x17	PIN7CTRL	7:0	INVEN				PULLUPEN	ISC[2:0]		

17.5 Register Description - PORTx

17.5.1 Data Direction

Name: DIR
Offset: 0x00
Reset: 0x00
Property: -

	7	6	5	4	3	2	1	0
	DIR[7:0]							
Access	R/W	R/W	R/W	R/W	R/W	R/W	R/W	R/W
Reset	0	0	0	0	0	0	0	0

Bits 7:0 – DIR[7:0] Data Direction

This bit field controls the output driver for each PORTx pin.

This bit field does not control the digital input buffer. The digital input buffer for pin n (Pxn) can be configured in the Input/Sense Configuration (ISC) bit field in the Pin n Control (PORTx.PINnCTRL) register.

The available configuration for each bit n in this bit field is shown in the table below.

Value	Description
0	Pxn is configured as an input-only pin, and the output driver is disabled
1	Pxn is configured as an output pin, and the output driver is enabled

17.5.2 Data Direction Set

Name: DIRSET
Offset: 0x01
Reset: 0x00
Property: -

	7	6	5	4	3	2	1	0
	DIRSET[7:0]							
Access	R/W	R/W	R/W	R/W	R/W	R/W	R/W	R/W
Reset	0	0	0	0	0	0	0	0

Bits 7:0 – DIRSET[7:0] Data Direction Set

This bit field controls the output driver for each PORTx pin, without using a read-modify-write operation.

Writing a '0' to bit n in this bit field has no effect.

Writing a '1' to bit n in this bit field will set the corresponding bit in PORTx.DIR, which will configure pin n (Pxn) as an output pin and enable the output driver.

Reading this bit field will return the value of PORTx.DIR.

17.5.3 Data Direction Clear

Name: DIRCLR
Offset: 0x02
Reset: 0x00
Property: -

	7	6	5	4	3	2	1	0
	DIRCLR[7:0]							
Access	R/W	R/W	R/W	R/W	R/W	R/W	R/W	R/W
Reset	0	0	0	0	0	0	0	0

Bits 7:0 – DIRCLR[7:0] Data Direction Clear

This bit field controls the output driver for each PORTx pin, without using a read-modify-write operation.

Writing a '0' to bit n in this bit field has no effect.

Writing a '1' to bit n in this bit field will clear the corresponding bit in PORTx.DIR, which will configure pin n (Pxn) as an input-only pin and disable the output driver.

Reading this bit field will return the value of PORTx.DIR.

17.5.4 Data Direction Toggle

Name: DIRTGL
Offset: 0x03
Reset: 0x00
Property: -

	7	6	5	4	3	2	1	0
	DIRTGL[7:0]							
Access	R/W	R/W	R/W	R/W	R/W	R/W	R/W	R/W
Reset	0	0	0	0	0	0	0	0

Bits 7:0 – DIRTGL[7:0] Data Direction Toggle

This bit field controls the output driver for each PORTx pin, without using a read-modify-write operation.

Writing a '0' to bit n in this bit field has no effect.

Writing a '1' to bit n in this bit field will toggle the corresponding bit in PORTx.DIR.

Reading this bit field will return the value of PORTx.DIR.

17.5.5 Output Value

Name: OUT
Offset: 0x04
Reset: 0x00
Property: -

Bit	7	6	5	4	3	2	1	0
	OUT[7:0]							
Access	R/W	R/W	R/W	R/W	R/W	R/W	R/W	R/W
Reset	0	0	0	0	0	0	0	0

Bits 7:0 – OUT[7:0] Output Value

This bit field controls the output driver level for each PORTx pin.

This configuration only has an effect when the output driver (PORTx.DIR) is enabled for the corresponding pin.

The available configuration for each bit n in this bit field is shown in the table below.

Value	Description
0	The pin n (Pxn) output is driven low
1	The Pxn output is driven high

17.5.6 Output Value Set

Name: OUTSET
Offset: 0x05
Reset: 0x00
Property: -

	7	6	5	4	3	2	1	0
	OUTSET[7:0]							
Access	R/W	R/W	R/W	R/W	R/W	R/W	R/W	R/W
Reset	0	0	0	0	0	0	0	0

Bits 7:0 – OUTSET[7:0] Output Value Set

This bit field controls the output driver level for each PORTx pin, without using a read-modify-write operation.

Writing a '0' to bit n in this bit field has no effect.

Writing a '1' to bit n in this bit field will set the corresponding bit in PORTx.OUT, which will configure the output for pin n (Pxn) to be driven high.

Reading this bit field will return the value of PORTx.OUT.

17.5.7 Output Value Clear

Name: OUTCLR
Offset: 0x06
Reset: 0x00
Property: -

	7	6	5	4	3	2	1	0
	OUTCLR[7:0]							
Access	R/W	R/W	R/W	R/W	R/W	R/W	R/W	R/W
Reset	0	0	0	0	0	0	0	0

Bits 7:0 – OUTCLR[7:0] Output Value Clear

This bit field controls the output driver level for each PORTx pin, without using a read-modify-write operation.

Writing a '0' to bit n in this bit field has no effect.

Writing a '1' to bit n in this bit field will clear the corresponding bit in PORTx.OUT, which will configure the output for pin n (Pxn) to be driven low.

Reading this bit field will return the value of PORTx.OUT.

17.5.8 Output Value Toggle

Name: OUTTGL
Offset: 0x07
Reset: 0x00
Property: -

	7	6	5	4	3	2	1	0
	OUTTGL[7:0]							
Access	R/W	R/W	R/W	R/W	R/W	R/W	R/W	R/W
Reset	0	0	0	0	0	0	0	0

Bits 7:0 – OUTTGL[7:0] Output Value Toggle

This bit field controls the output driver level for each PORTx pin, without using a read-modify-write operation.

Writing a '0' to bit n in this bit field has no effect.

Writing a '1' to bit n in this bit field will toggle the corresponding bit in PORTx.OUT.

Reading this bit field will return the value of PORTx.OUT.

17.5.9 Input Value

Name: IN
Offset: 0x08
Reset: 0x00
Property: -

	Bit	7	6	5	4	3	2	1	0
		IN[7:0]							
Access		R/W	R/W	R/W	R/W	R/W	R/W	R/W	R/W
Reset		0	0	0	0	0	0	0	0

Bits 7:0 – IN[7:0] Input Value

This bit field shows the state of the PORTx pins when the digital input buffer is enabled.

Writing a '0' to bit n in this bit field has no effect.

Writing a '1' to bit n in this bit field will toggle the corresponding bit in PORTx.OUT.

If the digital input buffer is disabled, the input is not sampled, and the bit value will not change. The digital input buffer for pin n (Pxn) can be configured in the Input/Sense Configuration (ISC) bit field in the Pin n Control (PORTx.PINnCTRL) register.

The available states of each bit n in this bit field is shown in the table below.

Value	Description
0	The voltage level on Pxn is low
1	The voltage level on Pxn is high

17.5.10 Interrupt Flags

Name: INTFLAGS
Offset: 0x09
Reset: 0x00
Property: -

	7	6	5	4	3	2	1	0
	INT[7:0]							
Access	R/W	R/W	R/W	R/W	R/W	R/W	R/W	R/W
Reset	0	0	0	0	0	0	0	0

Bits 7:0 – INT[7:0] Pin Interrupt Flag

Pin interrupt flag n is cleared by writing a '1' to it.

Pin interrupt flag n is set when the change or state of pin n (Pxn) matches the pin's Input/Sense Configuration (ISC) in PORTx.PINnCTRL.

Writing a '0' to bit n in this bit field has no effect.

Writing a '1' to bit n in this bit field will clear Pin interrupt flag n.

17.5.11 Port Control

Name: PORTCTRL
Offset: 0x0A
Reset: 0x00
Property: -

This register contains the slew rate limit enable bit for this port.

	7	6	5	4	3	2	1	0
Access								SRL
Reset								R/W
								0

Bit 0 – SRL Slew Rate Limit Enable

This bit controls slew rate limitation for all pins in PORTx.

Value	Description
0	Slew rate limitation is disabled for all pins in PORTx
1	Slew rate limitation is enabled for all pins in PORTx

17.5.12 Pin n Control

Name: PINnCTRL
Offset: 0x10 + n*0x01 [n=0..7]
Reset: 0x00
Property: -

	Bit	7	6	5	4	3	2	1	0
		INVEN				PULLUPEN		ISC[2:0]	
Access		R/W				R/W		R/W	R/W
Reset		0				0		0	0

Bit 7 – INVEN Inverted I/O Enable

This bit controls whether the input and output for pin n are inverted or not.

Value	Description
0	Input and output values are not inverted
1	Input and output values are inverted

Bit 3 – PULLUPEN Pull-up Enable

This bit controls whether the internal pull-up of pin n is enabled or not when the pin is configured as input-only.

Value	Description
0	Pull-up disabled
1	Pull-up enabled

Bits 2:0 – ISC[2:0] Input/Sense Configuration

This bit field controls the input and sense configuration of pin n. The sense configuration determines how a port interrupt can be triggered.

Value	Name	Description
0x0	INTDISABLE	Interrupt disabled but input buffer enabled
0x1	BOTHEDGES	Interrupt enabled with sense on both edges
0x2	RISING	Interrupt enabled with sense on rising edge
0x3	FALLING	Interrupt enabled with sense on falling edge
0x4	INPUT_DISABLE	Interrupt and digital input buffer disabled ⁽¹⁾
0x5	LEVEL	Interrupt enabled with sense on low level
other	—	Reserved

Note:

1. If the digital input buffer for pin n is disabled, bit n in the Input Value (PORTx.IN) register will not be updated.

17.6 Register Summary - VPORtx

Offset	Name	Bit Pos.	7	6	5	4	3	2	1	0
0x00	DIR	7:0								DIR[7:0]
0x01	OUT	7:0								OUT[7:0]
0x02	IN	7:0								IN[7:0]
0x03	INTFLAGS	7:0								INT[7:0]

17.7 Register Description - VPORtx

17.7.1 Data Direction

Name: DIR
Offset: 0x00
Reset: 0x00
Property: -

Access to the Virtual PORT registers has the same outcome as access to the regular registers but allows for memory specific instructions, such as bit manipulation instructions, which cannot be used in the extended I/O Register space where the regular PORT registers reside.

Bit	7	6	5	4	3	2	1	0
	DIR[7:0]							
Access	R/W	R/W	R/W	R/W	R/W	R/W	R/W	R/W
Reset	0	0	0	0	0	0	0	0

Bits 7:0 – DIR[7:0] Data Direction

This bit field controls the output driver for each PORTx pin.

This bit field does not control the digital input buffer. The digital input buffer for pin n (Pxn) can be configured in the Input/Sense Configuration (ISC) bit field in the Pin n Control (PORTx.PINnCTRL) register.

The available configuration for each bit n in this bit field is shown in the table below.

Value	Description
0	Pxn is configured as an input-only pin, and the output driver is disabled
1	Pxn is configured as an output pin, and the output driver is enabled

17.7.2 Output Value

Name: OUT
Offset: 0x01
Reset: 0x00
Property: -

Access to the Virtual PORT registers has the same outcome as access to the regular registers but allows for memory specific instructions, such as bit manipulation instructions, which cannot be used in the extended I/O Register space where the regular PORT registers reside.

Bit	7	6	5	4	3	2	1	0
	OUT[7:0]							
Access	R/W	R/W	R/W	R/W	R/W	R/W	R/W	R/W
Reset	0	0	0	0	0	0	0	0

Bits 7:0 – OUT[7:0] Output Value

This bit field controls the output driver level for each PORTx pin. This configuration only has an effect when the output driver (PORTx.DIR) is enabled for the corresponding pin. The available configuration for each bit n in this bit field is shown in the table below.

Value	Description
0	The pin n (Pxn) output is driven low
1	The Pxn output is driven high

17.7.3 Input Value

Name: IN
Offset: 0x02
Reset: 0x00
Property: -

Access to the Virtual PORT registers has the same outcome as access to the regular registers but allows for memory specific instructions, such as bit manipulation instructions, which cannot be used in the extended I/O Register space where the regular PORT registers reside.

Bit	7	6	5	4	3	2	1	0
	IN[7:0]							
Access	R/W	R/W	R/W	R/W	R/W	R/W	R/W	R/W
Reset	0	0	0	0	0	0	0	0

Bits 7:0 – IN[7:0] Input Value

This bit field shows the state of the PORTx pins when the digital input buffer is enabled.

Writing a '0' to bit n in this bit field has no effect.

Writing a '1' to bit n in this bit field will toggle the corresponding bit in PORTx.OUT.

If the digital input buffer is disabled, the input is not sampled, and the bit value will not change. The digital input buffer for pin n (Pxn) can be configured in the Input/Sense Configuration (ISC) bit field in the Pin n Control (PORTx.PINnCTRL) register.

The available states of each bit n in this bit field is shown in the table below.

Value	Description
0	The voltage level on Pxn is low
1	The voltage level on Pxn is high

17.7.4 Interrupt Flags

Name: INTFLAGS
Offset: 0x03
Reset: 0x00
Property: -

Access to the Virtual PORT registers has the same outcome as access to the regular registers but allows for memory specific instructions, such as bit manipulation instructions, which cannot be used in the extended I/O Register space where the regular PORT registers reside.

	7	6	5	4	3	2	1	0
	INT[7:0]							
Access	R/W	R/W	R/W	R/W	R/W	R/W	R/W	R/W
Reset	0	0	0	0	0	0	0	0

Bits 7:0 – INT[7:0] Pin Interrupt Flag

Pin interrupt flag n is cleared by writing a '1' to it.

Pin interrupt flag n is set when the change or state of pin n (Pxn) matches the pin's Input/Sense Configuration (ISC) in PORTx.PINnCTRL.

Writing a '0' to bit n in this bit field has no effect.

Writing a '1' to bit n in this bit field will clear Pin interrupt flag n.

18. BOD - Brown-out Detector

18.1 Features

- Brown-out Detector Monitors the Power Supply to Avoid Operation Below a Programmable Level
- Three Available Modes:
 - Enabled mode (continuously active)
 - Sampled mode
 - Disabled
- Separate Selection of Mode for Active and Sleep Modes
- Voltage Level Monitor (VLM) with Interrupt
- Programmable VLM Level Relative to the BOD Level

18.2 Overview

The Brown-out Detector (BOD) monitors the power supply and compares the supply voltage with the programmable brown-out threshold level. The brown-out threshold level defines when to generate a System Reset. The Voltage Level Monitor (VLM) monitors the power supply and compares it to a threshold higher than the BOD threshold. The VLM can then generate an interrupt as an “early warning” when the supply voltage is approaching the BOD threshold. The VLM threshold level is expressed as a percentage above the BOD threshold level.

The BOD is controlled mainly by fuses and has to be enabled by the user. The mode used in Standby sleep mode and Power-Down sleep mode can be altered in normal program execution. The VLM is controlled by I/O registers as well.

When activated, the BOD can operate in Enabled mode, where the BOD is continuously active, or in Sampled mode, where the BOD is activated briefly at a given period to check the supply voltage level.

18.2.1 Block Diagram

Figure 18-1. BOD Block Diagram

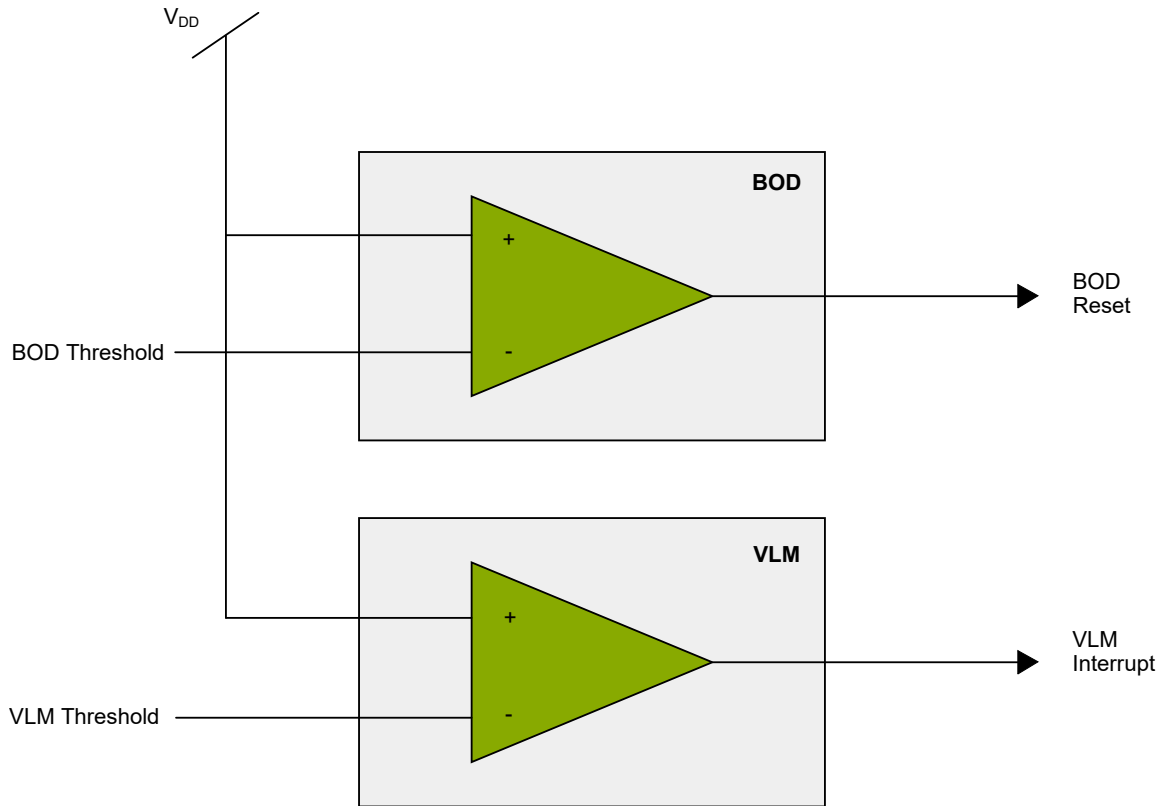

18.3 Functional Description

18.3.1 Initialization

The BOD settings are loaded from fuses during Reset. The BOD level and operating mode in Active and Idle sleep mode are set by fuses and cannot be changed by software. The operating mode in Standby and Power-Down sleep mode is loaded from fuses and can be changed by software.

The Voltage Level Monitor function can be enabled by writing a '1' to the VLM Interrupt Enable (VLMIE) bit in the Interrupt Control (BOD.INTCTRL) register. The VLM interrupt is configured by writing the VLM Configuration (VLMCFG) bits in BOD.INTCTRL. An interrupt is requested when the supply voltage crosses the VLM threshold either from above, below, or any direction.

The VLM functionality will follow the BOD mode. If the BOD is disabled, the VLM will not be enabled, even if the VLMIE is '1'. If the BOD is using Sampled mode, the VLM will also be sampled. When the VLM interrupt is enabled, the interrupt flag will be set according to VLMCFG when the voltage level is crossing the VLM level.

The VLM threshold is defined by writing the VLM Level (VLMLVL) bits in the Control A (BOD.VLMCTRLA) register.

18.3.2 Interrupts

Table 18-1. Available Interrupt Vectors and Sources

Name	Vector Description	Conditions
VLM	Voltage Level Monitor	Supply voltage crossing the VLM threshold as configured by the VLM Configuration (VLMCFG) bit field in the Interrupt Control (BOD.INTCTRL) register

The VLM interrupt will not be executed if the CPU is halted in Debug mode.

When an interrupt condition occurs, the corresponding interrupt flag is set in the peripheral's Interrupt Flags (*peripheral*.INTFLAGS) register.

An interrupt source is enabled or disabled by writing to the corresponding enable bit in the peripheral's Interrupt Control (*peripheral*.INTCTRL) register.

An interrupt request is generated when the corresponding interrupt source is enabled, and the interrupt flag is set. The interrupt request remains active until the interrupt flag is cleared. See the peripheral's INTFLAGS register for details on how to clear interrupt flags.

18.3.3 Sleep Mode Operation

The BOD configuration in the different sleep modes is defined by fuses. The mode used in Active mode and Idle sleep mode is defined by the ACTIVE fuses in FUSE.BODCFG, which is loaded into the ACTIVE bit field in the Control A (BOD.CTRLA) register. The mode used in Standby sleep mode and Power-Down sleep mode is defined by SLEEP in FUSE.BODCFG, which is loaded into the SLEEP bit field in the Control A (BOD.CTRLA) register.

The operating mode in Active mode and Idle sleep mode (i.e., ACTIVE in BOD.CTRLA) cannot be altered by software. The operating mode in Standby sleep mode and Power-Down sleep mode can be altered by writing to the SLEEP bit field in the Control A (BOD.CTRLA) register.

When the device is going into Standby or Power-Down sleep mode, the BOD will change the operation mode as defined by SLEEP in BOD.CTRLA. When the device is waking up from Standby or Power-Down sleep mode, the BOD will operate in the mode defined by the ACTIVE bit field in the Control A (BOD.CTRLA) register.

18.3.4 Configuration Change Protection

This peripheral has registers that are under Configuration Change Protection (CCP). To write to these registers, a certain key must first be written to the CPU.CCP register, followed by a write access to the protected bits within four CPU instructions.

Attempting to write to a protected register without following the appropriate CCP unlock sequence leaves the protected register unchanged.

The following registers are under CCP:

Table 18-2. Registers Under Configuration Change Protection

Register	Key
SLEEP in BOD.CTRLA	IOREG

18.4 Register Summary

Offset	Name	Bit Pos.	7	6	5	4	3	2	1	0
0x00	CTRLA	7:0				SAMPFREQ		ACTIVE[1:0]		SLEEP[1:0]
0x01	CTRLB	7:0								LVL[2:0]
0x02	Reserved									
...										
0x07										
0x08		VLMCTRLA	7:0							
0x09	INTCTRL	7:0							VLMCFG[1:0]	VLMIE
0x0A	INTFLAGS	7:0								VLMIF
0x0B	STATUS	7:0								VLMS

18.5 Register Description

18.5.1 Control A

Name: CTRLA
Offset: 0x00
Reset: Loaded from fuse
Property: Configuration Change Protection

Bit	7	6	5	4	3	2	1	0
				SAMPFREQ	ACTIVE[1:0]		SLEEP[1:0]	
Access				R	R	R	R/W	R/W
Reset				x	x	x	x	x

Bit 4 – SAMPFREQ Sample Frequency

This bit controls the BOD sample frequency.

The Reset value is loaded from the SAMPFREQ bit in FUSE.BODCFG.

This bit is not under Configuration Change Protection (CCP).

Value	Description
0x0	Sample frequency is 1 kHz
0x1	Sample frequency is 125 Hz

Bits 3:2 – ACTIVE[1:0] Active

These bits select the BOD operation mode when the device is in Active or Idle mode.

The Reset value is loaded from the ACTIVE bit field in FUSE.BODCFG.

This bit field is not under Configuration Change Protection (CCP).

Value	Name	Description
0x0	DIS	Disabled
0x1	ENABLED	Enabled in continuous mode
0x2	SAMPLED	Enabled in sampled mode
0x3	ENWAKE	Enabled in continuous mode. Execution is halted at wake-up until BOD is running

Bits 1:0 – SLEEP[1:0] Sleep

These bits select the BOD operation mode when the device is in Standby or Power-Down sleep mode. The Reset value is loaded from the SLEEP bit field in FUSE.BODCFG.

Value	Name	Description
0x0	DIS	Disabled
0x1	ENABLED	Enabled in continuous mode
0x2	SAMPLED	Enabled in sampled mode
0x3	-	Reserved

18.5.2 Control B

Name: CTRLB
Offset: 0x01
Reset: Loaded from fuse
Property: -

Bit	7	6	5	4	3	2	1	0
						LVL[2:0]		
Access	R	R	R	R	R	R	R	R
Reset	0	0	0	0	0	x	x	x

Bits 2:0 – LVL[2:0] BOD Level

This bit field controls the BOD threshold level.

The Reset value is loaded from the BOD Level (LVL) bits in the BOD Configuration Fuse (FUSE.BODCFG).

Value	Name	Description
0x0	BODLEVEL0	1.8V
0x2	BODLEVEL2	2.6V
0x7	BODLEVEL7	4.2V

Notes:

- Refer to the *BOD and POR Characteristics* in *Electrical Characteristics* for further details
- Values in the description are typical values

18.5.3 VLM Control A

Name: VLMCTRLA
Offset: 0x08
Reset: 0x00
Property: -

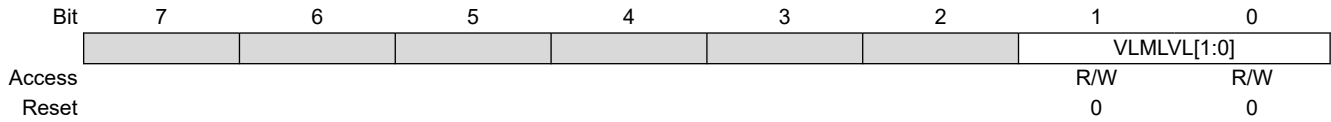

Bits 1:0 – VLMLVL[1:0] VLM Level

These bits select the VLM threshold relative to the BOD threshold (LVL in BOD.CTRLB).

Value	Description
0x0	VLM threshold 5% above BOD threshold
0x1	VLM threshold 15% above BOD threshold
0x2	VLM threshold 25% above BOD threshold
other	Reserved

18.5.4 Interrupt Control

Name: INTCTRL
Offset: 0x09
Reset: 0x00
Property: -

Bit	7	6	5	4	3	2	1	0
						VLMCFG[1:0]		VLMIE
Access						R/W	R/W	R/W
Reset						0	0	0

Bits 2:1 – VLMCFG[1:0] VLM Configuration

These bits select which incidents will trigger a VLM interrupt.

Value	Name	Description
0x0	BELOW	V _{DD} falls below VLM threshold
0x1	ABOVE	V _{DD} rises above VLM threshold
0x2	CROSS	V _{DD} crosses VLM threshold
Other	-	Reserved

Bit 0 – VLMIE VLM Interrupt Enable

Writing a '1' to this bit enables the VLM interrupt.

18.5.5 VLM Interrupt Flags

Name: INTFLAGS
Offset: 0x0A
Reset: 0x00
Property: -

Bit	7	6	5	4	3	2	1	0
Access								VLMIF
Reset								0

Bit 0 – VLMIF VLM Interrupt Flag

This flag is set when a trigger from the VLM is given, as configured by the VLMCFG bit in the BOD.INTCTRL register. The flag is only updated when the BOD is enabled.

18.5.6 VLM Status

Name: STATUS
Offset: 0x0B
Reset: 0x00
Property: -

Bit	7	6	5	4	3	2	1	0
								VLMS
Access								R
Reset								0

Bit 0 – VLMS VLM Status

This bit is only valid when the BOD is enabled.

Value	Description
0	The voltage is above the VLM threshold level
1	The voltage is below the VLM threshold level

19. VREF - Voltage Reference

19.1 Features

- Programmable Voltage Reference Source for:
 - AC
 - ADC
- Each Reference Source Supports the Following Voltages:
 - 1.024V
 - 2.048V
 - 2.500V
 - 4.096V
 - VDD

19.2 Overview

The Voltage Reference (VREF) peripheral provides voltage reference sources used by several peripherals. The user can select the reference voltages for the Analog Comparators by writing to the appropriate bit field in the Control A (VREF.CTRLA) register.

A voltage reference source is enabled automatically when requested by a peripheral. The user can enable the reference voltage sources (and thus, override the automatic disabling of unused sources) by writing to the respective ALWAYS ON bit in the Control B (VREF.CTRLB) register. This will decrease the start-up time at the cost of increased power consumption.

19.2.1 Block Diagram

Figure 19-1. VREF Block Diagram

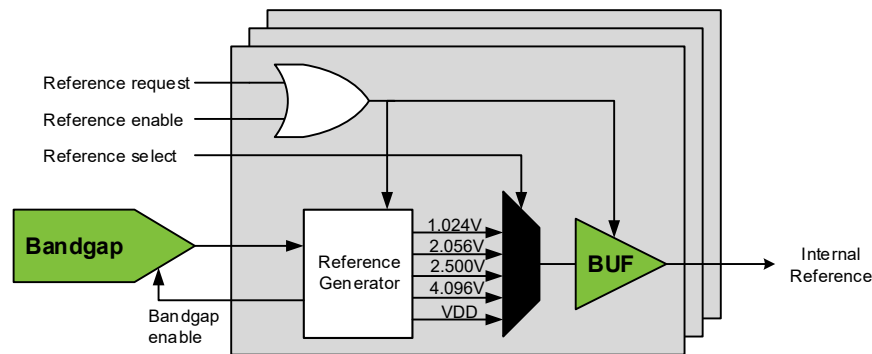

19.3 Functional Description

19.3.1 Initialization

The default configuration will enable the respective source when the ADC0 or the AC0 are requesting a reference voltage.

The voltage references for the ADC0 and AC0 can be forced ON by writing a '1' to the respective Reference Force Enable bits (ADC0REFEN and AC0REFEN) in the Control B (VREF.CTRLB) register. This serves to reduce the start-up time of the respective peripheral.

The default reference voltage for the AC0 is 1.024V but can be configured by writing to the AC0 Reference Select (AC0REFSEL) bit field in the Control A (VREF.CTRLA) register.

ATtiny3224/3226/3227

VREF - Voltage Reference

The reference voltage for the ADC0 is configured by selecting the reference source within the ADC0 registers. Refer to the ADC documentation for details.

19.4 Register Summary

Offset	Name	Bit Pos.	7	6	5	4	3	2	1	0
0x00	CTRLA	7:0						AC0REFSEL[2:0]		
0x01	CTRLB	7:0						NVMREFEN	ADC0REFEN	AC0REFEN

19.5 Register Description

19.5.1 Control A

Name: CTRLA
Offset: 0x00
Reset: 0x00
Property: -

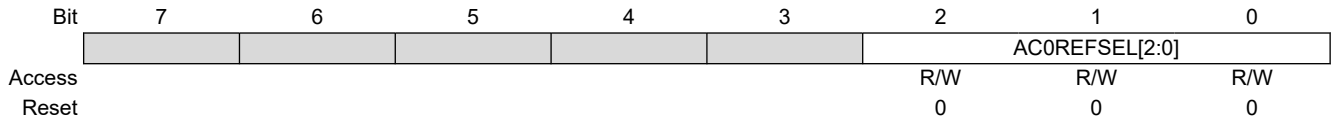

Bits 2:0 – AC0REFSEL[2:0] Analog Comparator 0 Reference Select
 This bit field controls the reference voltage for the Analog Comparator 0.

Note:

- The values given for internal references are only typical. Refer to the *Electrical Characteristics* section for further details.

Value	Name	Description
0x0	1V024	1.02V reference ⁽¹⁾
0x1	2V048	2.05V reference ⁽¹⁾
0x2	2V500	2.5V reference ⁽¹⁾
0x3	4V096	4.1V reference ⁽¹⁾
0x7	VDD	Supply voltage as reference
Other	-	Reserved

19.5.2 Control B

Name: CTRLB
Offset: 0x01
Reset: 0x00
Property: -

Bit	7	6	5	4	3	2	1	0
						NVMREFEN	ADC0REFEN	AC0REFEN
Access						R/W	R/W	R/W
Reset						0	0	0

Bit 2 – NVMREFEN NVM Reference Force Enable

This bit field controls whether the NVMREFEN reference is always on or not.

Value	Name	Description
0	AUTO	The reference is automatically enabled when needed
1	ALWAYSON	The reference is always on

Bit 1 – ADC0REFEN ADC0 Reference Force Enable

This bit field controls whether the ADC0 reference is always on or not.

Value	Name	Description
0	AUTO	The reference is automatically enabled when needed
1	ALWAYSON	The reference is always on

Bit 0 – AC0REFEN AC0 DACREF Reference Force Enable

This bit field controls whether the AC0 DACREF is always on or not.

Value	Name	Description
0	AUTO	The reference is automatically enabled when needed
1	ALWAYSON	The reference is always on

20. WDT - Watchdog Timer

20.1 Features

- Issues a System Reset if the Watchdog Timer Is Not Cleared Before Its Time-Out Period
- Operates Asynchronously from the Peripheral Clock Using an Independent Oscillator
- Uses the 1.024 kHz Output of the 32.768 kHz Ultra-Low Power Oscillator (OSCULP32K)
- 11 Selectable Time-Out Periods, from 8 ms to 8s
- Two Operation Modes:
 - Normal mode
 - Window mode
- Configuration Lock to Prevent Unwanted Changes

20.2 Overview

The Watchdog Timer (WDT) is a system function for monitoring the correct program operation. When enabled, the WDT is a constantly running timer with a configurable time-out period. If the WDT is not reset within the time-out period, it will issue a system Reset. This allows the system to recover from situations such as runaway or deadlocked code. The WDT is reset by executing the `WDR` (Watchdog Timer Reset) instruction from software.

In addition to the Normal mode as described above, the WDT has a Window mode. The Window mode defines a time slot or “window” inside the time-out period during which the WDT must be reset. If the WDT is reset outside this window, either too early or too late, a system Reset will be issued. Compared to the Normal mode, the Window mode can catch situations where a code error causes constant `WDR` execution.

When enabled, the WDT will run in Active mode and all sleep modes. Since it is asynchronous (that is running from a CPU independent clock source), it will continue to operate and be able to issue a system Reset, even if the main clock fails.

The WDT has a Configuration Change Protection (CCP) mechanism and a lock functionality, ensuring the WDT settings cannot be changed by accident.

20.2.1 Block Diagram

Figure 20-1. WDT Block Diagram

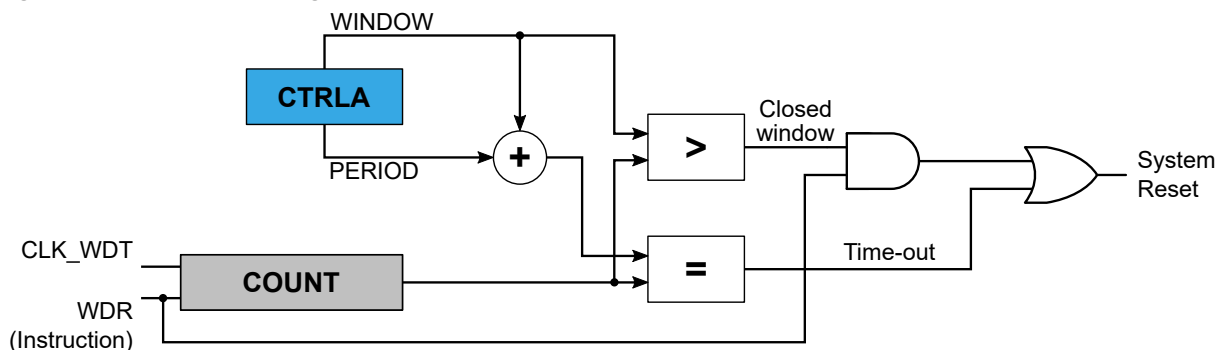

20.2.2 Signal Description

Not applicable.

20.3 Functional Description

20.3.1 Initialization

1. The WDT is enabled when a non-zero value is written to the Period (PERIOD) bit field in the Control A (WDT.CTRLA) register.
2. Optional: Write a non-zero value to the Window (WINDOW) bit field in WDT.CTRLA to enable the Window mode operation.

All bits in the Control A register and the Lock (LOCK) bit in the Status (WDT.STATUS) register are write-protected by the Configuration Change Protection (CCP) mechanism.

A fuse (FUSE.WDTCFG) defines the Reset value of the WDT.CTRLA register. If the value of the PERIOD bit field in the FUSE.WDTCFG fuse is different than zero, the WDT is enabled and the LOCK bit in the WDT.STATUS register is set at boot time.

20.3.2 Clocks

A 1.024 kHz oscillator clock (CLK_WDT_OSC) is sourced from the internal Ultra-Low Power Oscillator, OSCULP32K. Due to the ultra-low power design, the oscillator is less accurate than other oscillators featured in the device, and hence the exact time-out period may vary from device to device. This variation must be taken into consideration when designing software that uses the WDT to ensure that the time-out periods used are valid for all devices. Refer to the “*Electrical Characteristics*” section for more specific information.

The counter clock (CLK_WDT_OSC) is asynchronous to the peripheral clock. Due to this asynchronicity, writing to the WDT Control register will require synchronization between the clock domains. Refer to [20.3.6. Synchronization](#) for further details.

20.3.3 Operation

20.3.3.1 Normal Mode

In Normal mode operation, a single time-out period is set for the WDT. If the WDT is not reset from software using the `WDR` instruction during the defined time-out period, the WDT will issue a system Reset.

A new WDT time-out period will start each time the WDT resets the `WDR`.

There are 11 possible WDT time-out periods (TO_{WDT}), selectable from 8 ms to 8s by writing to the Period (PERIOD) bit field in the Control A (WDT.CTRLA) register.

The figure below shows a typical timing scheme for the WDT operating in Normal mode.

Figure 20-2. Normal Mode Operation

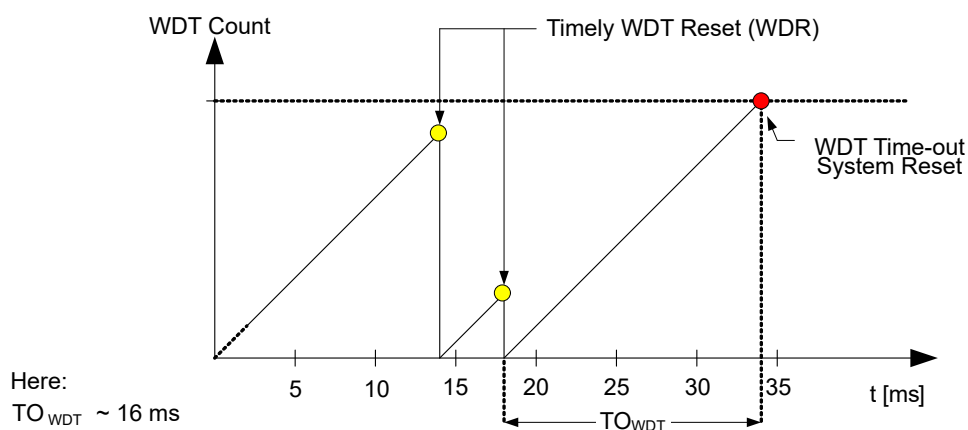

Normal mode is enabled as long as the Window (WINDOW) bit field in the WDT.CTRLA register is 0x0.

20.3.3.2 Window Mode

In the Window mode operation, the WDT uses two different time-out periods:

- The closed window time-out period (TO_{WDTW}) defines a duration, from 8 ms to 8s, where the WDT cannot be reset. If the WDT is reset during this period, the WDT will issue a system Reset.
- The open window time-out period (TO_{WDT}), which is also 8 ms to 8s, defines the duration of the open period during which the WDT can (and needs to) be reset. The open period will always follow the closed period, so the total duration of the time-out period is the sum of the closed window and the open window time-out periods.

When enabling the Window mode or when going out of the Debug mode, the window is activated after the first WDR instruction.

The figure below shows a typical timing scheme for the WDT operating in Window mode.

Figure 20-3. Window Mode Operation

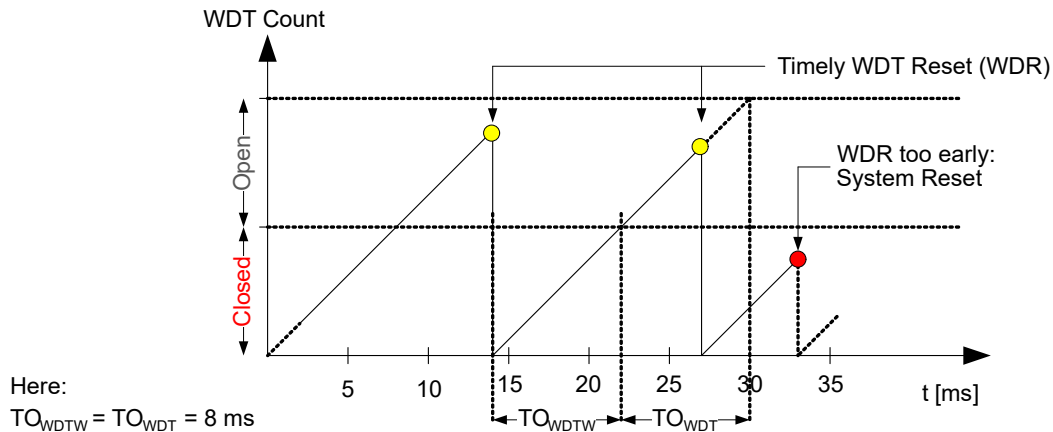

The Window mode is enabled by writing a non-zero value to the Window (WINDOW) bit field in the Control A (WDT.CTRLA) register. The Window mode is disabled by writing the WINDOW bit field to '0x0'.

20.3.3.3 Preventing Unintentional Changes

The WDT provides two security mechanisms to avoid unintentional changes to the WDT settings:

- The CCP mechanism, employing a timed write procedure for changing the WDT control registers. Refer to [20.3.7. Configuration Change Protection](#) for further details.
- Locking the configuration by writing a '1' to the Lock (LOCK) bit in the Status (WDT.STATUS) register. When this bit is '1', the Control A (WDT.CTRLA) register cannot be changed. The LOCK bit can only be written to '1' in software, while the device needs to be in Debug mode to be able to write it to '0'. Consequently, the WDT cannot be disabled from software.

Note: The WDT configuration is loaded from fuses after Reset. If the PERIOD bit field is set to a non-zero value, the LOCK bit is automatically set in WDT.STATUS.

20.3.4 Sleep Mode Operation

The WDT will continue to operate in any sleep mode where the source clock is active.

20.3.5 Debug Operation

When run-time debugging, this peripheral will continue normal operation. Halting the CPU in Debugging mode will halt the normal operation of the peripheral.

When halting the CPU in Debug mode, the WDT counter is reset.

When starting the CPU and when the WDT is operating in Window mode, the first closed window time-out period will be disabled, and a Normal mode time-out period is executed.

20.3.6 Synchronization

The Control A (WDT.CTRLA) register is synchronized when written, due to the asynchronicity between the WDT clock domain and the peripheral clock domain. The Synchronization Busy (SYNCBUSY) flag in the STATUS (WDT.STATUS) register indicates if there is an ongoing synchronization.

Writing to WDT.CTRLA while SYNCBUSY = 1 is not allowed.

The following bit fields must be synchronized when written:

- The Period (PERIOD) bit field in Control A (WDT.CTRLA) register
- The Window (WINDOW) bit field in Control A (WDT.CTRLA) register

The WDR instruction will need two to three cycles of the WDT clock to be synchronized.

20.3.7 Configuration Change Protection

This peripheral has registers that are under Configuration Change Protection (CCP). To write to these registers, a certain key must first be written to the CPU.CCP register, followed by a write access to the protected bits within four CPU instructions.

Attempting to write to a protected register without following the appropriate CCP unlock sequence leaves the protected register unchanged.

The following registers are under CCP:

Table 20-1. WDT - Registers Under Configuration Change Protection

Register	Key
WDT.CTRLA	IOREG
LOCK bit in WDT.STATUS	IOREG

20.4 Register Summary

Offset	Name	Bit Pos.	7	6	5	4	3	2	1	0
0x00	CTRLA	7:0	WINDOW[3:0]				PERIOD[3:0]			
0x01	STATUS	7:0	LOCK							SYNCBUSY

20.5 Register Description

20.5.1 Control A

Name: CTRLA
Offset: 0x00
Reset: From FUSE.WDTCFG
Property: Configuration Change Protection

Bit	7	6	5	4	3	2	1	0
	WINDOW[3:0]				PERIOD[3:0]			
Access	R/W	R/W	R/W	R/W	R/W	R/W	R/W	R/W
Reset	x	x	x	x	x	x	x	x

Bits 7:4 – WINDOW[3:0] Window

Writing a non-zero value to these bits enables the Window mode, and selects the duration of the closed period accordingly.

The bits are optionally lock-protected:

- If the LOCK bit in WDT.STATUS is '1' all bits are change-protected (Access = R)
- If the LOCK bit in WDT.STATUS is '0' all bits can be changed (Access = R/W)

Value	Name	Description
0x0	OFF	-
0x1	8CLK	0.008s
0x2	16CLK	0.016s
0x3	32CLK	0.031s
0x4	64CLK	0.063s
0x5	128CLK	0.125s
0x6	256CLK	0.25s
0x7	512CLK	0.5s
0x8	1KCLK	1s
0x9	2KCLK	2s
0xA	4KCLK	4s
0xB	8KCLK	8s
Other	-	Reserved

Note: Refer to the *Electrical Characteristics* section for specific information regarding the accuracy of the 32.768 kHz Ultra-Low Power Oscillator (OSCULP32K).

Bits 3:0 – PERIOD[3:0] Period

Writing a non-zero value to this bit enables the WDT and selects the time-out period in Normal mode accordingly. In Window mode, these bits select the duration of the open window.

The bits are optionally lock-protected:

- If the LOCK bit in WDT.STATUS is '1' all bits are change-protected (Access = R)
- If the LOCK bit in WDT.STATUS is '0' all bits can be changed (Access = R/W)

Value	Name	Description
0x0	OFF	-
0x1	8CLK	0.008s
0x2	16CLK	0.016s
0x3	32CLK	0.031s
0x4	64CLK	0.063s
0x5	128CLK	0.125s
0x6	256CLK	0.25s
0x7	512CLK	0.5s
0x8	1KCLK	1s
0x9	2KCLK	2s
0xA	4KCLK	4s

ATtiny3224/3226/3227

WDT - Watchdog Timer

Value	Name	Description
0xB	8KCLK	8s
Other	-	Reserved

Note: Refer to the *Electrical Characteristics* section for specific information regarding the accuracy of the 32.768 kHz Ultra-Low Power Oscillator (OSCULP32K).

20.5.2 Status

Name: STATUS
Offset: 0x01
Reset: 0x00
Property: Configuration Change Protection

	7	6	5	4	3	2	1	0
	LOCK							SYNCBUSY
Access	R/W							R
Reset	0							0

Bit 7 – LOCK Lock

Writing this bit to '1' write-protects the WDT.CTRLA register.

It is only possible to write this bit to '1'. This bit can be cleared in Debug mode only.

If the PERIOD bits in WDT.CTRLA are different from zero after boot code, the lock will automatically be set.

This bit is under CCP.

Bit 0 – SYNCBUSY Synchronization Busy

This bit is set after writing to the WDT.CTRLA register, while the data is being synchronized from the peripheral clock domain to the WDT clock domain.

This bit is cleared after the synchronization is finished.

This bit is not under CCP.

21. TCA - 16-bit Timer/Counter Type A

21.1 Features

- 16-Bit Timer/Counter
- Three Compare Channels
- Double-Buffered Timer Period Setting
- Double-Buffered Compare Channels
- Waveform Generation:
 - Frequency generation
 - Single-slope PWM (Pulse-Width Modulation)
 - Dual-slope PWM
- Count on Event
- Timer Overflow Interrupts/Events
- One Compare Match per Compare Channel
- Two 8-Bit Timer/Counters in Split Mode

21.2 Overview

The flexible 16-bit PWM Timer/Counter type A (TCA) provides accurate program execution timing, frequency and waveform generation, and command execution.

A TCA consists of a base counter and a set of compare channels. The base counter can be used to count clock cycles or events or let events control how it counts clock cycles. It has direction control and period setting that can be used for timing. The compare channels can be used together with the base counter to perform a compare match control, frequency generation, and pulse-width waveform modulation.

Depending on the mode of operation, the counter is cleared, reloaded, incremented, or decremented at each timer/counter clock or event input.

A timer/counter can be clocked and timed from the peripheral clock, with optional prescaling, or from the Event System. The Event System can also be used for direction control or to synchronize operations.

By default, the TCA is a 16-bit timer/counter. The timer/counter has a Split mode feature that splits it into two 8-bit timer/counters with three compare channels each.

A block diagram of the 16-bit timer/counter with closely related peripheral modules (in grey) is shown in the figure below.

Figure 21-1. 16-bit Timer/Counter and Closely Related Peripherals

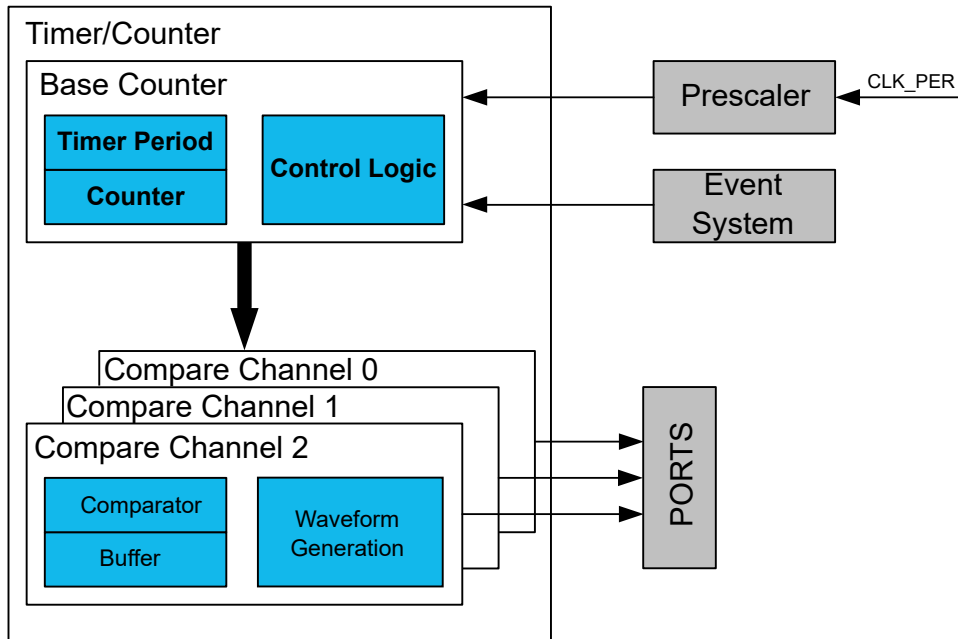

21.2.1 Block Diagram

The figure below shows a detailed block diagram of the timer/counter.

Figure 21-2. Timer/Counter Block Diagram

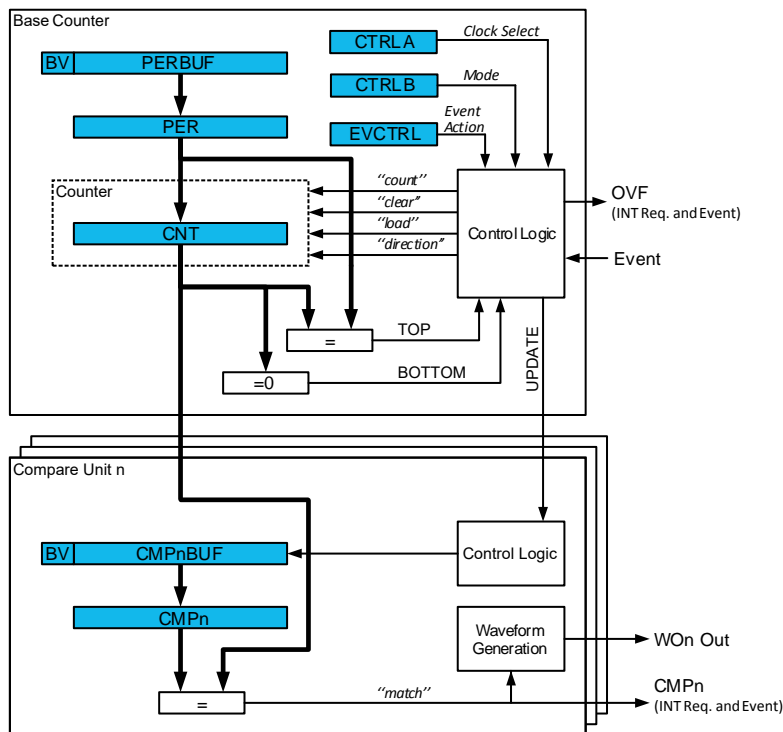

The Counter (TCA_n.CNT) register, Period and Compare (TCA_n.PER and TCA_n.CMP_n) registers, and their corresponding buffer registers (TCA_n.PERBUF and TCA_n.CMP_nBUF) are 16-bit registers. All buffer registers have a Buffer Valid (BV) flag that indicates when the buffer contains a new value.

During normal operation, the counter value is continuously compared to zero and the period (PER) value to determine whether the counter has reached TOP or BOTTOM. The counter value can also be compared to the TCA_n.CMP_n registers.

The timer/counter can generate interrupt requests, events, or change the waveform output after being triggered by the Counter (TCA_n.CNT) register reaching TOP, BOTTOM, or CMP_n. The interrupt requests, events, or waveform output changes will occur on the next CLK_TCA cycle after the triggering.

CLK_TCA is either the prescaled peripheral clock or events from the Event System, as shown in the figure below.

Figure 21-3. Timer/Counter Clock Logic

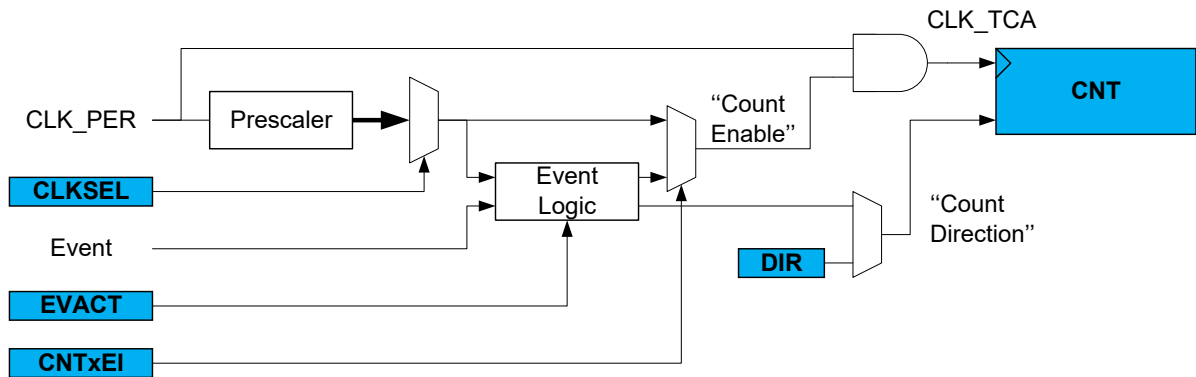

21.2.2 Signal Description

Signal	Description	Type
WOn	Digital output	Waveform output

21.3 Functional Description

21.3.1 Definitions

The following definitions are used throughout the documentation:

Table 21-1. Timer/Counter Definitions

Name	Description
BOTTOM	The counter reaches BOTTOM when it becomes 0x0000
MAX	The counter reaches MAXimum when it becomes all ones
TOP	The counter reaches TOP when it becomes equal to the highest value in the count sequence
UPDATE	The update condition is met when the timer/counter reaches BOTTOM or TOP, depending on the Waveform Generator mode. Buffered registers with valid buffer values will be updated unless the Lock Update (LUPD) bit in the TCA _n .CTRLC register has been set.
CNT	Counter register value
CMP	Compare register value
PER	Period register value

In general, the term timer is used when the timer/counter is counting periodic clock ticks. The term counter is used when the input signal has sporadic or irregular ticks. The latter can be the case when counting events.

21.3.2 Initialization

To start using the timer/counter in a basic mode, follow these steps:

1. Write a TOP value to the Period (TCA_n.PER) register.
2. Enable the peripheral by writing a '1' to the Enable (ENABLE) bit in the Control A (TCA_n.CTRLA) register. The counter will start counting clock ticks according to the prescaler setting in the Clock Select (CLKSEL) bit field in TCA_n.CTRLA.
3. Optional: By writing a '1' to the Enable Counter Event Input A (CNTAEI) bit in the Event Control (TCA_n.EVCTRL) register, events are counted instead of clock ticks.
4. The counter value can be read from the Counter (CNT) bit field in the Counter (TCA_n.CNT) register.

21.3.3 Operation

21.3.3.1 Normal Operation

In normal operation the counter is counting clock ticks in the direction selected by the Direction (DIR) bit in the Control E (TCA_n.CTRL E) register until it reaches TOP or BOTTOM. The clock ticks are given by the peripheral clock (CLK_PER), prescaled according to the Clock Select (CLKSEL) bit field in the Control A (TCA_n.CTRLA) register.

When TOP is reached while the counter is counting up, the counter will wrap to '0' at the next clock tick. When counting down, the counter is reloaded with the Period (TCA_n.PER) register value when the BOTTOM is reached.

Figure 21-4. Normal Operation

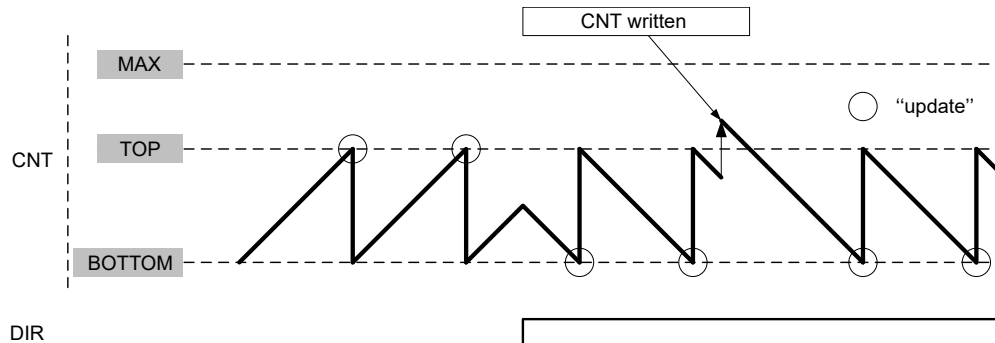

It is possible to change the counter value in the Counter (TCA_n.CNT) register when the counter is running. The write access to TCA_n.CNT register has higher priority than count, clear or reload, and will be immediate. The direction of the counter can also be changed during normal operation by writing to the Direction (DIR) bit in the Control E (TCA_n.CTRL E) register.

21.3.3.2 Double Buffering

The Period (TCA_n.PER) register value and the Compare *n* (TCA_n.CMP_n) register values are all double-buffered (TCA_n.PERBUF and TCA_n.CMP_nBUF).

Each buffer register has a Buffer Valid (BV) flag (PERBV, CMP_nBV) in the Control F (TCA_n.CTRL F) register, which indicates that the buffer register contains a valid (new) value that can be copied into the corresponding Period or Compare register. When the Period register and Compare *n* registers are used for a compare operation, the BV flag is set when data are written to the buffer register and cleared on an UPDATE condition. This is shown for a Compare (CMP_n) register in the figure below.

Figure 21-5. Period and Compare Double Buffering

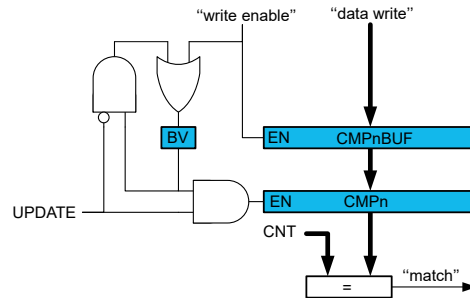

Both the TCA_n.CMP_n and TCA_n.CMP_nBUF registers are available as I/O registers. This allows the initialization and bypassing of the buffer register and the double-buffering function.

21.3.3.3 Changing the Period

The Counter period is changed by writing a new TOP value to the Period (TCA_n.PER) register.

No Buffering: If double-buffering is not used, any period update is immediate.

Figure 21-6. Changing the Period Without Buffering

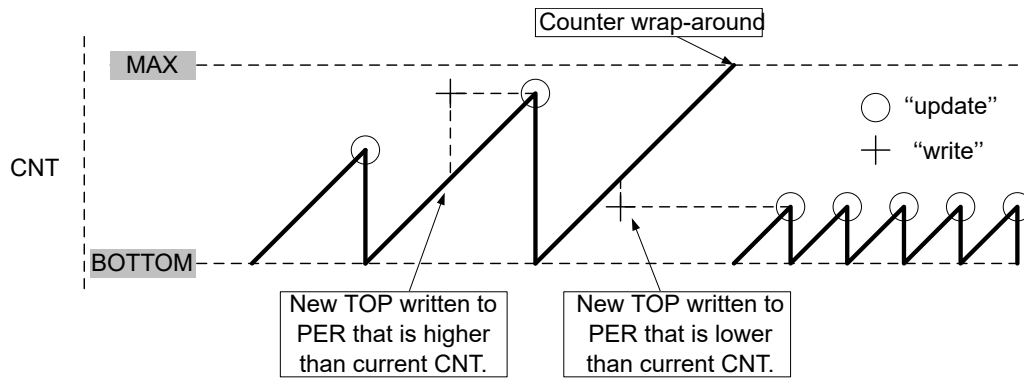

A counter wrap-around can occur in any mode of operation when counting up without buffering, as the TCA_n.CNT and TCA_n.PER registers are continuously compared. If a new TOP value is written to TCA_n.PER that is lower than the current TCA_n.CNT, the counter will wrap first, before a compare match occurs.

Figure 21-7. Unbuffered Dual-Slope Operation

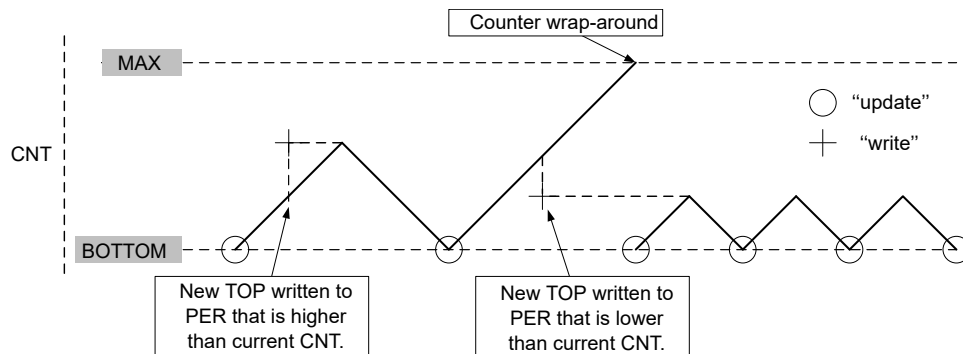

With Buffering: When double-buffering is used, the buffer can be written at any time and still maintain the correct operation. The TCA_n.PER is always updated on the UPDATE condition, as shown for dual-slope operation in the figure below. This prevents wrap-around and the generation of odd waveforms.

Figure 21-8. Changing the Period Using Buffering

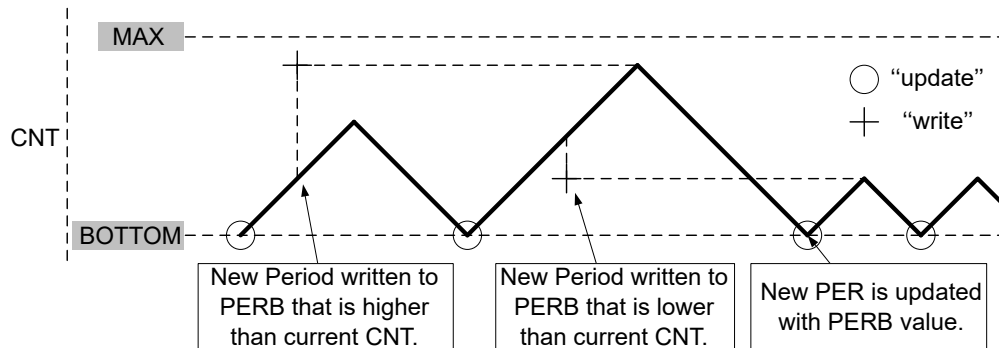

Note: Buffering is used in figures illustrating TCA operation if not otherwise specified.

21.3.3.4 Compare Channel

Each Compare Channel *n* continuously compares the counter value (TCA_n.CNT) with the Compare *n* (TCA_n.CMP_n) register. If TCA_n.CNT equals TCA_n.CMP_n the Comparator *n* signals a match. The match will set the Compare Channel's interrupt flag at the next timer clock cycle, and the optional interrupt is generated.

The Compare *n* Buffer (TCA_n.CMP_nBUF) register provides double-buffer capability equivalent to that for the period buffer. The double-buffering synchronizes the update of the TCA_n.CMP_n register with the buffer value to either the TOP or BOTTOM of the counting sequence, according to the UPDATE condition. The synchronization prevents the occurrence of odd-length, non-symmetrical pulses for glitch-free output.

The value in CMP_nBUF is moved to CMP_n at the UPDATE condition and is compared to the counter value (TCA_n.CNT) from the next count.

21.3.3.4.1 Waveform Generation

The compare channels can be used for waveform generation on the corresponding port pins. The following requirements must be met to make the waveform visible on the connected port pin:

1. A Waveform Generation mode must be selected by writing the Waveform Generation Mode (WGMODE) bit field in the TCA_n.CTRLB register.
2. The compare channels used must be enabled (CMP_nEN = 1 in TCA_n.CTRLB). This will override the output value for the corresponding pin. An alternative pin can be selected by configuring the Port Multiplexer (PORTMUX). Refer to the *PORTMUX* section for details.
3. The direction for the associated port pin *n* must be configured in the Port peripheral as an output.
4. Optional: Enable the inverted waveform output for the associated port pin *n*. Refer to the *PORT* section for details.

21.3.3.4.2 Frequency (FRQ) Waveform Generation

For frequency generation, the period time (*T*) is controlled by the TCA_n.CMP₀ register instead of the Period (TCA_n.PER) register. The corresponding waveform generator output is toggled on each compare match between the TCA_n.CNT and TCA_n.CMP_n registers.

Figure 21-9. Frequency Waveform Generation

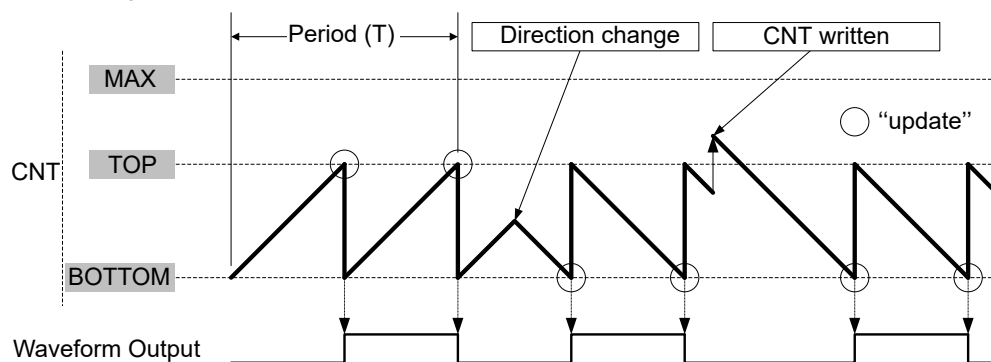

The following equation defines the waveform frequency (f_{FRQ}):

$$f_{FRQ} = \frac{f_{CLK_PER}}{2N(CMP0+1)}$$

where N represents the prescaler divider used (see the CLKSEL bit field in the TCA n .CTRLA register), and f_{CLK_PER} is the peripheral clock frequency.

The maximum frequency of the waveform generated is half of the peripheral clock frequency ($f_{CLK_PER}/2$) when TCA n .CMP0 is written to 0x0000 and no prescaling is used ($N = 1$, CLKSEL = 0x0 in TCA n .CTRLA).

Use the TCA n .CMP1 and TCA n .CMP2 registers to get additional waveform outputs WOn. The waveforms WOn can either be identical or offset to WO0. The offset can be influenced by TCA n .CMP n , TCA n .CNT and the count direction. The offset in seconds t_{Offset} can be calculated using the equations in the table below. The equations are only valid when $CMPn < CMP0$.

Table 21-2. Offset equation overview

Equation	Count Direction	CMPn vs CNT State	Offset
$t_{Offset} = \left(\frac{CMP0 - CMPn}{CMP0 + 1}\right)\left(\frac{T}{2}\right)$	UP	CMPn ≥ CNT	WOn leading WO0
	DOWN	CMP0 ≤ CNT	WOn trailing WO0
		CMP0 > CNT and CMPn > CNT	WOn trailing WO0
$t_{Offset} = \left(\frac{CMPn + 1}{CMP0 + 1}\right)\left(\frac{T}{2}\right)$	UP	CMPn < CNT	WOn trailing WO0
	DOWN	CMPn ≤ CNT	WOn leading WO0

The figure below shows leading and trailing offset for WOn, where both equations can be used. The correct equation is determined by count direction, and the state of CMPn vs CNT when the timer is enabled or CMPn is changed.

Figure 21-10. Offset When Counting Up

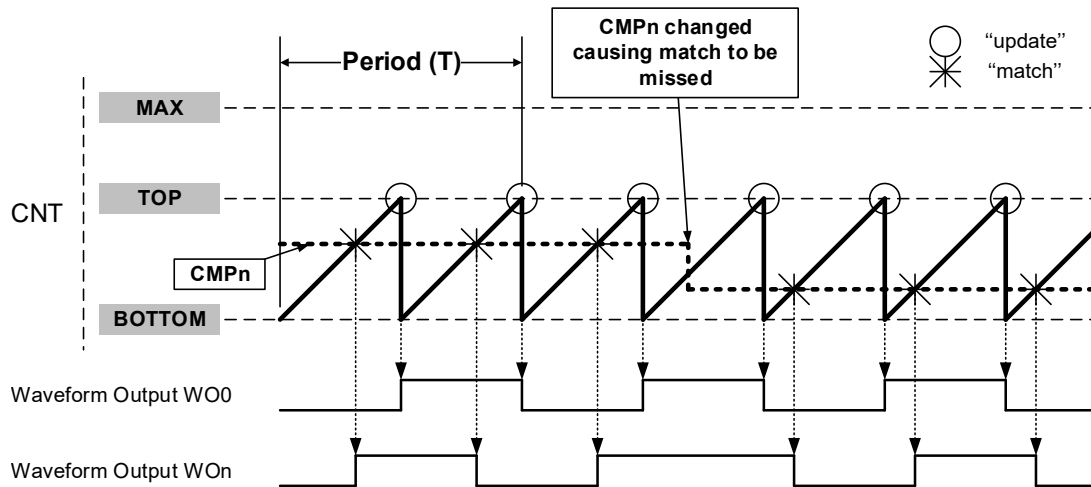

The figure below shows how the waveform can be inverted by changing CMPn during run-time.

Figure 21-11. Inverting Waveform Output

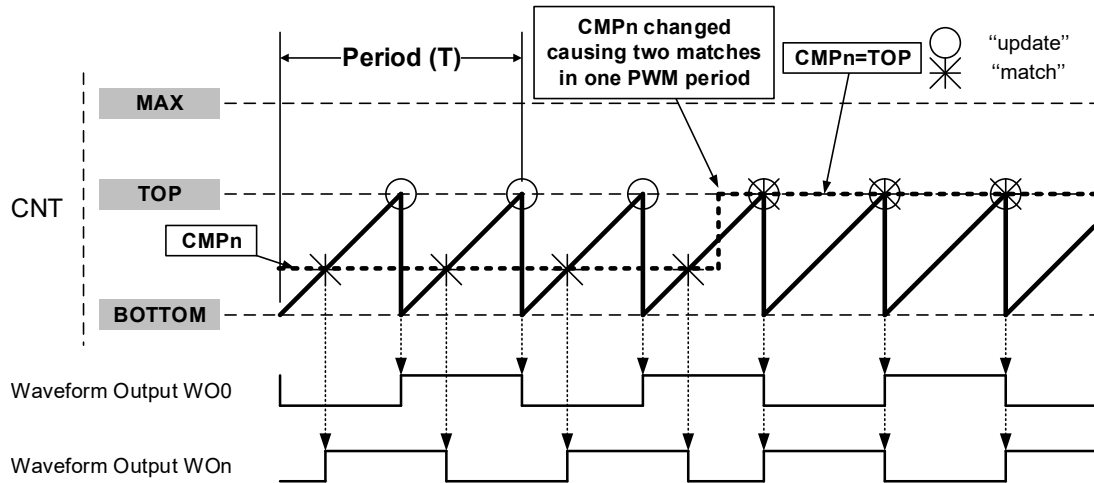

21.3.3.4.3 Single-Slope PWM Generation

For single-slope Pulse-Width Modulation (PWM) generation, the period (T) is controlled by the TCA_n.PER register, while the values of the TCA_n.CMP_n registers control the duty cycles of the generated waveforms. The figure below shows how the counter counts from BOTTOM to TOP and then restarts from BOTTOM. The waveform generator output is set at BOTTOM and cleared on the compare match between the TCA_n.CNT and TCA_n.CMP_n registers.

CMP_n = BOTTOM will produce a static low signal on WOn while CMP_n > TOP will produce a static high signal on WOn.

Figure 21-12. Single-Slope Pulse-Width Modulation

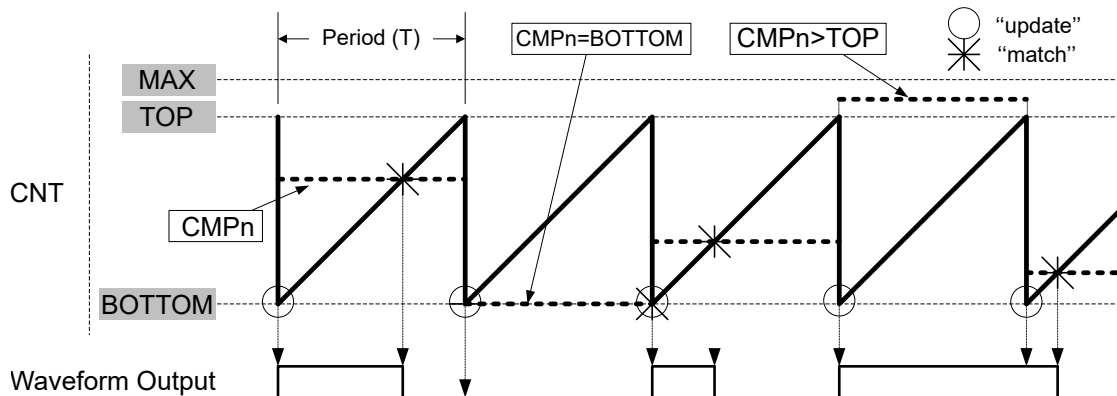

Notes:

1. The representation in the figure above is valid when CMP_n is updated using CMP_nBUF.
2. For single-slope Pulse-Width Modulation (PWM) generation, the counter counting from TOP to BOTTOM is not supported.

The TCA_n.PER register defines the PWM resolution. The minimum resolution is 2 bits (TCA_n.PER = 0x0003), and the maximum resolution is 16 bits (TCA_n.PER = MAX).

The following equation calculates the exact resolution in bits for single-slope PWM (R_{PWM_SS}):

$$R_{PWM_SS} = \frac{\log(PER+1)}{\log(2)}$$

The single-slope PWM frequency (f_{PWM_SS}) depends on the period setting (TCA_n.PER), the peripheral clock frequency f_{CLK_PER} and the TCA prescaler (the CLKSEL bit field in the TCA_n.CTRLA register). It is calculated by the following equation where N represents the prescaler divider used:

$$f_{PWM_SS} = \frac{f_{CLK_PER}}{N(PER+1)}$$

21.3.3.4.4 Dual-Slope PWM

For the dual-slope PWM generation, the period (T) is controlled by TCA_n.PER, while the values of TCA_n.CMP_n control the duty cycle of the WG output.

The figure below shows how, for dual-slope PWM, the counter repeatedly counts from BOTTOM to TOP and then from TOP to BOTTOM. The waveform generator output is set at BOTTOM, cleared on compare match when up-counting, and set on compare match when down-counting.

CMP_n = BOTTOM produces a static low signal on WOn, while CMP_n = TOP produces a static high signal on WOn.

Figure 21-13. Dual-Slope Pulse-Width Modulation

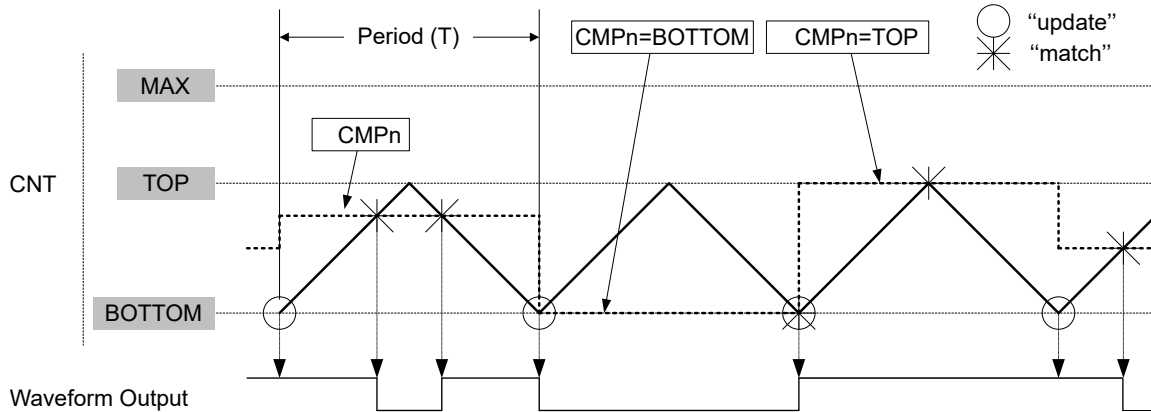

Note: The representation in the figure above is valid when CMP_n is updated using CMP_nBUF.

The Period (TCA_n.PER) register defines the PWM resolution. The minimum resolution is 2 bits (TCA_n.PER = 0x0003), and the maximum resolution is 16 bits (TCA_n.PER = MAX).

The following equation calculates the exact resolution in bits for dual-slope PWM (R_{PWM_DS}):

$$R_{PWM_DS} = \frac{\log(PER+1)}{\log(2)}$$

The PWM frequency depends on the period setting in the TCA_n.PER register, the peripheral clock frequency (f_{CLK_PER}), and the prescaler divider selected in the CLKSEL bit field in the TCA_n.CTRLA register. It is calculated by the following equation:

$$f_{PWM_DS} = \frac{f_{CLK_PER}}{2N \cdot PER}$$

N represents the prescaler divider used.

Using dual-slope PWM results in approximately half the maximum operation frequency compared to single-slope PWM operation, due to twice the number of timer increments per period.

21.3.3.4.5 Port Override for Waveform Generation

To make the waveform generation available on the port pins, the corresponding port pin direction must be set as output (PORT_x.DIR[n] = 1). The TCA will override the port pin values when the compare channel is enabled (CMP_nEN = 1 in the TCA_n.CTRLB register), and a Waveform Generation mode is selected.

The figure below shows the port override for TCA. The timer/counter compare channel will override the port pin output value (PORT_x.OUT) on the corresponding port pin. Enabling inverted I/O on the port pin (INVEN = 1 in the PORT_x.PINnCTRL register) inverts the corresponding WG output.

Figure 21-14. Port Override for Timer/Counter Type A

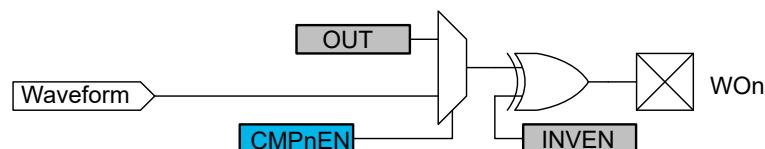

21.3.3.5 Timer/Counter Commands

A set of commands can be issued by software to immediately change the state of the peripheral. These commands give direct control of the UPDATE, RESTART and RESET signals. A command is issued by writing the respective value to the Command (CMD) bit field in the Control E (TCAn.CTRLESET) register.

An UPDATE command has the same effect as when an UPDATE condition occurs, except that the UPDATE command is not affected by the state of the Lock Update (LUPD) bit in the Control E (TCAn.CTRLE) register.

The software can force a restart of the current waveform period by issuing a RESTART command. In this case, the counter, direction, and all compare outputs are set to '0'.

A RESET command will set all timer/counter registers to their initial values. A RESET command can be issued only when the timer/counter is not running (ENABLE = 0 in the TCAn.CTRLA register).

21.3.3.6 Split Mode - Two 8-Bit Timer/Counters

Split Mode Overview

To double the number of timers and PWM channels in the TCA, a Split mode is provided. In this Split mode, the 16-bit timer/counter acts as two separate 8-bit timers, which each have three compare channels for PWM generation. The Split mode will only work with single-slope down-count. Event controlled operation is not supported in Split mode.

The figure below shows single-slope PWM generation in Split mode. The waveform generator output is cleared at BOTTOM, and set on compare match between the counter value (TCAn.CNT) and the Compare n (TCAn.CMPn) register.

Figure 21-15. Single-Slope Pulse-Width Modulation in Split mode

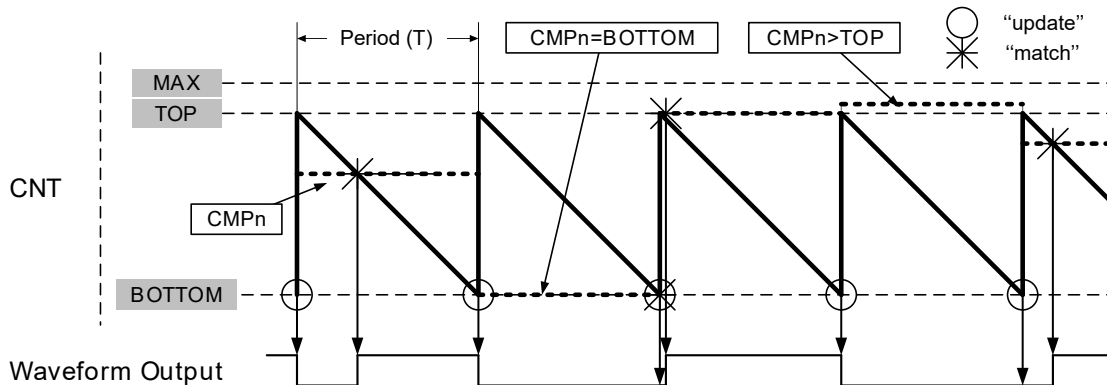

Note: The maximum duty-cycle of the waveform output is $TOP/(TOP+1)$

Activating Split mode results in changes to the functionality of some registers and register bits. The modifications are described in a separate register map (see [21.6. Register Summary - Split Mode](#)).

Split Mode Differences Compared to Normal Mode

- Count:
 - Down-count only
 - Low Byte Timer Counter (TCAn.LCNT) register and High Byte Timer Counter (TCAn.HCNT) register are independent
- Waveform generation:
 - Single-slope PWM only (WGMODE = SINGLESLOPE in the TCAn.CTRLB register)
- Interrupt:
 - No change for Low Byte Timer Counter (TCAn.LCNT) register
 - Underflow interrupt for High Byte Timer Counter (TCAn.HCNT) register
 - No compare interrupt or flag for High Byte Compare n (TCAn.HCMPn) register
- Event Actions: Not compatible
- Buffer registers and buffer valid flags: Unused

- Register Access: Byte access to all registers

Block Diagram

Figure 21-16. Timer/Counter Block Diagram Split Mode

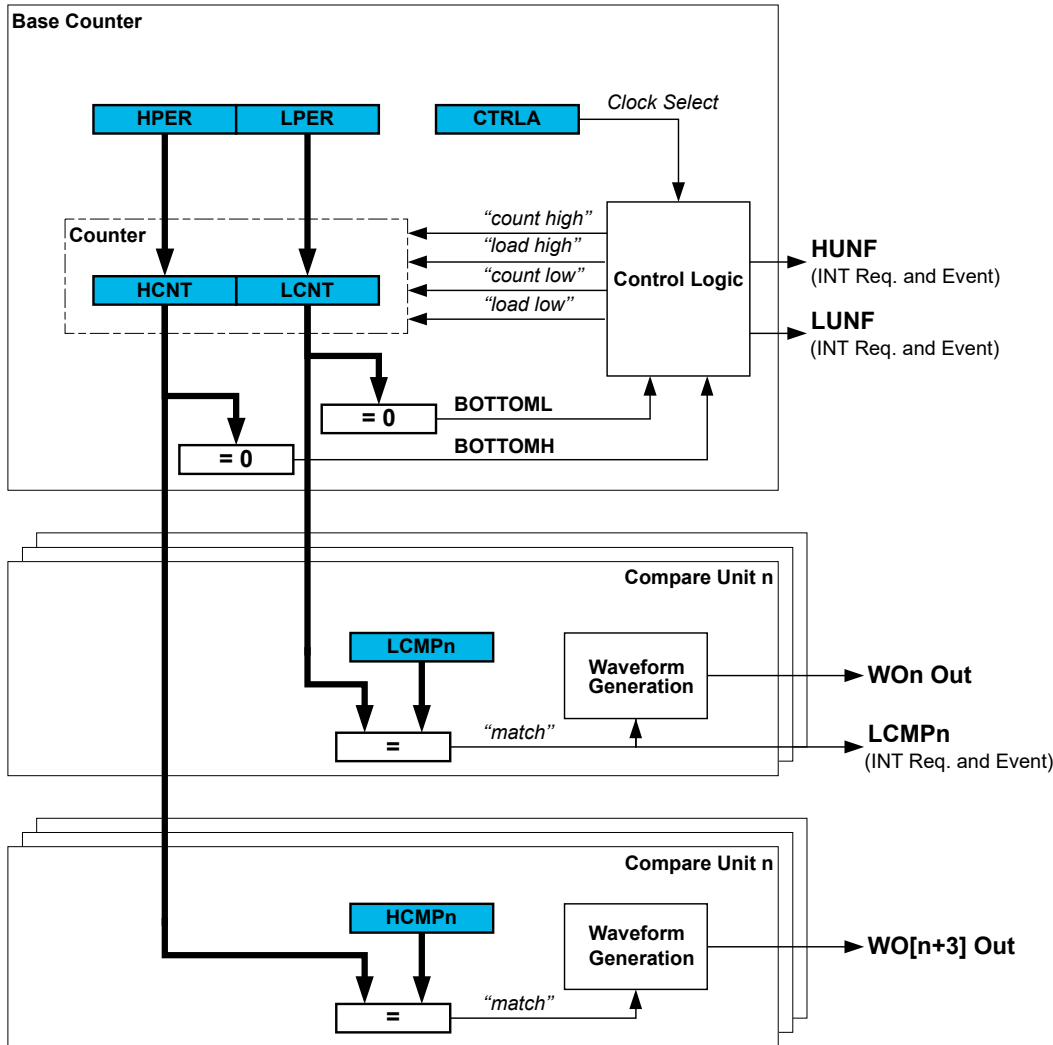

Split Mode Initialization

When shifting between Normal mode and Split mode, the functionality of some registers and bits changes, but their values do not. For this reason, disabling the peripheral (ENABLE = 0 in the TCA_n.CTRLA register) and doing a hard Reset (CMD = RESET in the TCA_n.CTRLESET register) is recommended when changing the mode to avoid unexpected behavior.

To start using the timer/counter in basic Split mode after a hard Reset, follow these steps:

1. Enable Split mode by writing a '1' to the Split mode enable (SPLITM) bit in the Control D (TCA_n.CTRLD) register.
2. Write a TOP value to the Period (TCA_n.PER) registers.
3. Enable the peripheral by writing a '1' to the Enable (ENABLE) bit in the Control A (TCA_n.CTRLA) register. The counter will start counting clock ticks according to the prescaler setting in the Clock Select (CLKSEL) bit field in the TCA_n.CTRLA register.
4. The counter values can be read from the Counter bit field in the Counter (TCA_n.CNT) registers.

21.3.4 Events

The TCA can generate the events described in the table below. All event generators except TCA_n_HUNF are shared between Normal mode and Split mode operation, and the generator name indicates what specific signal the generator represents in each mode in the following way: OVF_LUNF corresponds to overflow in Normal mode and Low byte timer underflow in Split mode. The same applies to CMP_n_LCMP_n.

Table 21-3. Event Generators in TCA

Generator Name		Description	Event Type	Generating Clock Domain	Length of Event
Peripheral	Event				
TCA _n	OVF_LUNF	Normal mode: Overflow Split mode: Low byte timer underflow	Pulse	CLK_PER	One CLK_PER period
	HUNF	Normal mode: Not available Split mode: High byte timer underflow	Pulse	CLK_PER	One CLK_PER period
	CMP0_LCMP0	Normal mode: Compare Channel 0 match Split mode: Low byte timer Compare Channel 0 match	Pulse	CLK_PER	One CLK_PER period
	CMP1_LCMP1	Normal mode: Compare Channel 1 match Split mode: Low byte timer Compare Channel 1 match	Pulse	CLK_PER	One CLK_PER period
	CMP2_LCMP2	Normal mode: Compare Channel 2 match Split mode: Low byte timer Compare Channel 2 match	Pulse	CLK_PER	One CLK_PER period

Note: The conditions for generating an event are identical to those that will raise the corresponding interrupt flag in the TCA_n.INTFLAGS register for both Normal mode and Split mode.

The TCA has two event users for detecting and acting upon input events. The table below describes the event users and their associated functionality.

Table 21-4. Event Users in TCA

User Name		Description	Input Detection	Async/Sync
Peripheral	Input			
TCA _n	CNTA	Count on a positive event edge	Edge	Sync
		Count on any event edge	Edge	Sync
		Count while the event signal is high	Level	Sync
		The event level controls the count direction, up when low and down when high	Level	Sync
	CNTB	The event level controls count direction, up when low and down when high	Level	Sync
		Restart counter on a positive event edge	Edge	Sync
		Restart counter on any event edge	Edge	Sync
		Restart counter while the event signal is high	Level	Sync

The specific actions described in the table above are selected by writing to the Event Action (EVACTA, EVACTB) bits in the Event Control (TCA_n.EVCTRL) register. Input events are enabled by writing a '1' to the Enable Counter Event Input (CNTAEI and CNTBEI) bits in the TCA_n.EVCTRL register.

If both EVACTA and EVACTB are configured to control the count direction, the event signals will be OR'ed to determine the count direction. Both event inputs must then be low for the counter to count upwards.

Notes:

1. Event inputs are not used in Split mode.
2. Event actions with level input detection only work reliably if the event frequency is less than the timer's frequency.

Refer to the *Event System (EVSYS)* section for more details regarding event types and Event System configuration.

21.3.5 Interrupts

Table 21-5. Available Interrupt Vectors and Sources in Normal Mode

Name	Vector Description	Conditions
OVF	Overflow or underflow interrupt	The counter has reached TOP or BOTTOM
CMP0	Compare Channel 0 interrupt	Match between the counter value and the Compare 0 register
CMP1	Compare Channel 1 interrupt	Match between the counter value and the Compare 1 register
CMP2	Compare Channel 2 interrupt	Match between the counter value and the Compare 2 register

Table 21-6. Available Interrupt Vectors and Sources in Split Mode

Name	Vector Description	Conditions
LUNF	Low-byte Underflow interrupt	Low byte timer reaches BOTTOM
HUNF	High-byte Underflow interrupt	High byte timer reaches BOTTOM
LCMP0	Compare Channel 0 interrupt	Match between the counter value and the low byte of the Compare 0 register
LCMP1	Compare Channel 1 interrupt	Match between the counter value and the low byte of the Compare 1 register

.....continued

Name	Vector Description	Conditions
LCMP2	Compare Channel 2 interrupt	Match between the counter value and the low byte of the Compare 2 register

When an interrupt condition occurs, the corresponding interrupt flag is set in the peripheral's Interrupt Flags (*peripheral*.INTFLAGS) register.

An interrupt source is enabled or disabled by writing to the corresponding enable bit in the peripheral's Interrupt Control (*peripheral*.INTCTRL) register.

An interrupt request is generated when the corresponding interrupt source is enabled, and the interrupt flag is set. The interrupt request remains active until the interrupt flag is cleared. See the peripheral's INTFLAGS register for details on how to clear interrupt flags.

21.3.6 Sleep Mode Operation

TCA is by default disabled in Standby sleep mode. It will be halted as soon as the sleep mode is entered.

The module can stay fully operational in Standby sleep mode if the Run Standby (RUNSTDBY) bit in the TCA_n.CTRLA register is written to '1'.

All operation is halted in Power-Down sleep mode.

21.4 Register Summary - Normal Mode

Offset	Name	Bit Pos.	7	6	5	4	3	2	1	0
0x00	CTRLA	7:0	RUNSTDBY					CLKSEL[2:0]		ENABLE
0x01	CTRLB	7:0		CMP2EN	CMP1EN	CMP0EN	ALUPD	WGMODE[2:0]		
0x02	CTRLC	7:0						CMP2OV	CMP1OV	CMP0OV
0x03	CTRLD	7:0								SPLITM
0x04	CTRLECLR	7:0					CMD[1:0]		LUPD	DIR
0x05	CTRLESET	7:0					CMD[1:0]		LUPD	DIR
0x06	CTRLFCLR	7:0					CMP2BV	CMP1BV	CMP0BV	PERBV
0x07	CTRLFSET	7:0					CMP2BV	CMP1BV	CMP0BV	PERBV
0x08	Reserved									
0x09	EVCTRL	7:0		EVACTB[2:0]		CNTBEI	EVACTA[2:0]			CNTAEI
0x0A	INTCTRL	7:0		CMP2	CMP1	CMP0				OVF
0x0B	INTFLAGS	7:0		CMP2	CMP1	CMP0				OVF
0x0C	Reserved									
...										
0x0D	Reserved									
0x0E	DBGCTRL	7:0								DBGRUN
0x0F	TEMP	7:0	TEMP[7:0]							
0x10	Reserved									
...										
0x1F	Reserved									
0x20	CNT	7:0	CNT[7:0]							
		15:8	CNT[15:8]							
0x22	Reserved									
...										
0x25	Reserved									
0x26	PER	7:0	PER[7:0]							
		15:8	PER[15:8]							
0x28	CMP0	7:0	CMP[7:0]							
		15:8	CMP[15:8]							
0x2A	CMP1	7:0	CMP[7:0]							
		15:8	CMP[15:8]							
0x2C	CMP2	7:0	CMP[7:0]							
		15:8	CMP[15:8]							
0x2E	Reserved									
...										
0x35	Reserved									
0x36	PERBUF	7:0	PERBUF[7:0]							
		15:8	PERBUF[15:8]							
0x38	CMP0BUF	7:0	CMPBUF[7:0]							
		15:8	CMPBUF[15:8]							
0x3A	CMP1BUF	7:0	CMPBUF[7:0]							
		15:8	CMPBUF[15:8]							
0x3C	CMP2BUF	7:0	CMPBUF[7:0]							
		15:8	CMPBUF[15:8]							

21.5 Register Description - Normal Mode

21.5.1 Control A - Normal Mode

Name: CTRLA
Offset: 0x00
Reset: 0x00
Property: -

	Bit	7	6	5	4	3	2	1	0
		RUNSTDBY					CLKSEL[2:0]		ENABLE
Access		R/W				R/W	R/W	R/W	R/W
Reset		0				0	0	0	0

Bit 7 – RUNSTDBY Run Standby

Writing a '1' to this bit will enable the peripheral to run in Standby sleep mode.

Bits 3:1 – CLKSEL[2:0] Clock Select

These bits select the clock frequency for the timer/counter.

Value	Name	Description
0x0	DIV1	$f_{TCA} = f_{CLK_PER}$
0x1	DIV2	$f_{TCA} = f_{CLK_PER}/2$
0x2	DIV4	$f_{TCA} = f_{CLK_PER}/4$
0x3	DIV8	$f_{TCA} = f_{CLK_PER}/8$
0x4	DIV16	$f_{TCA} = f_{CLK_PER}/16$
0x5	DIV64	$f_{TCA} = f_{CLK_PER}/64$
0x6	DIV256	$f_{TCA} = f_{CLK_PER}/256$
0x7	DIV1024	$f_{TCA} = f_{CLK_PER}/1024$

Bit 0 – ENABLE Enable

Value	Description
0	The peripheral is disabled
1	The peripheral is enabled

21.5.2 Control B - Normal Mode

Name: CTRLB
Offset: 0x01
Reset: 0x00
Property: -

	Bit	7	6	5	4	3	2	1	0
			CMP2EN	CMP1EN	CMP0EN	ALUPD	WGMODE[2:0]		
Access			R/W	R/W	R/W	R/W	R/W	R/W	R/W
Reset			0	0	0	0	0	0	0

Bits 4, 5, 6 – CMPEN Compare n Enable

In the FRQ and PWM Waveform Generation modes, the Compare n Enable (CMPnEN) bits will make the waveform output available on the pin corresponding to WOn, overriding the value in the corresponding PORT output register. The corresponding pin direction must be configured as an output in the PORT peripheral.

Value	Description
0	Waveform output WOn will not be available on the corresponding pin
1	Waveform output WOn will override the output value of the corresponding pin

Bit 3 – ALUPD Auto-Lock Update

The Auto-Lock Update bit controls the Lock Update (LUPD) bit in the TCAn.CTRLE register. When ALUPD is written to '1', the LUPD bit will be set to '1' until the Buffer Valid (CMPnBV) bits of all enabled compare channels are '1'. This condition will clear the LUPD bit.

It will remain cleared until the next UPDATE condition, where the buffer values will be transferred to the CMPn registers, and the LUPD bit will be set to '1' again. This makes sure that the CMPnBUF register values are not transferred to the CMPn registers until all enabled compare buffers are written.

Value	Description
0	LUPD bit in the TCAn.CTRLE register is not altered by the system
1	LUPD bit in the TCAn.CTRLE register is set and cleared automatically

Bits 2:0 – WGMODE[2:0] Waveform Generation Mode

This bit field selects the Waveform Generation mode and controls the counting sequence of the counter, TOP value, UPDATE condition, Interrupt condition, and the type of waveform generated.

No waveform generation is performed in the Normal mode of operation. For all other modes, the waveform generator output will only be directed to the port pins if the corresponding CMPnEN bit has been set. The port pin direction must be set as output.

Table 21-7. Timer Waveform Generation Mode

Value	Group Configuration	Mode of Operation	TOP	UPDATE	OVF
0x0	NORMAL	Normal	PER	TOP ⁽¹⁾	TOP ⁽¹⁾
0x1	FRQ	Frequency	CMP0	TOP ⁽¹⁾	TOP ⁽¹⁾
0x2	-	Reserved	-	-	-
0x3	SINGLESLOPE	Single-slope PWM	PER	BOTTOM	BOTTOM
0x4	-	Reserved	-	-	-
0x5	DSTOP	Dual-slope PWM	PER	BOTTOM	TOP
0x6	DSBOTH	Dual-slope PWM	PER	BOTTOM	TOP and BOTTOM
0x7	DSBOTTOM	Dual-slope PWM	PER	BOTTOM	BOTTOM

Note:

1. When counting up.

21.5.3 Control C - Normal Mode

Name: CTRLC
Offset: 0x02
Reset: 0x00
Property: -

	7	6	5	4	3	2	1	0
Access						CMP2OV	CMP1OV	CMP0OV
Reset						R/W	R/W	R/W
						0	0	0

Bit 2 – CMP2OV Compare Output Value 2
 See CMP0OV.

Bit 1 – CMP1OV Compare Output Value 1
 See CMP0OV.

Bit 0 – CMP0OV Compare Output Value 0
 The CMPnOV bits allow direct access to the waveform generator’s output compare value when the timer/counter is not enabled. This is used to set or clear the WG output value when the timer/counter is not running.

Note: When the output is connected to the pad, overriding these bits will not work unless the CMPnEN bits in the TCAn.CTRLB register have been set. If the output is connected to CCL, the CMPnEN bits in the TCAn.CTRLB register are bypassed.

21.5.4 Control D - Normal Mode

Name: CTRLD
Offset: 0x03
Reset: 0x00
Property: -

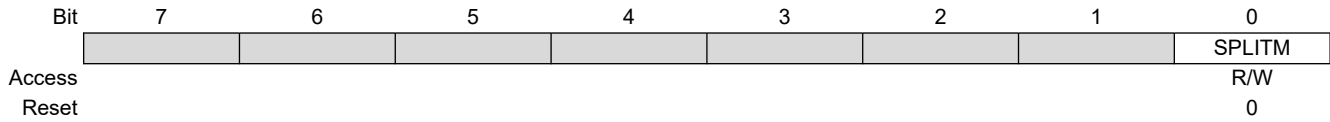

Bit 0 – SPLITM Enable Split Mode

This bit sets the timer/counter in Split mode operation and will work as two 8-bit timer/counters. The register map will change compared to the normal 16-bit mode.

21.5.5 Control Register E Clear - Normal Mode

Name: CTRLECLR
Offset: 0x04
Reset: 0x00
Property: -

Use this register instead of a Read-Modify-Write (RMW) to clear individual bits by writing a '1' to its bit location.

	7	6	5	4	3	2	1	0
					CMD[1:0]		LUPD	DIR
Access					R/W	R/W	R/W	R/W
Reset					0	0	0	0

Bits 3:2 – CMD[1:0] Command

This bit field is used for software control of update, restart, and Reset of the timer/counter. The command bit field is always read as '0'.

Value	Name	Description
0x0	NONE	No command
0x1	UPDATE	Force update
0x2	RESTART	Force restart
0x3	RESET	Force hard Reset (ignored if the timer/counter is enabled)

Bit 1 – LUPD Lock Update

Lock update can be used to ensure that all buffers are valid before an update is performed.

Value	Description
0	The buffered registers are updated as soon as an UPDATE condition has occurred
1	No update of the buffered registers is performed, even though an UPDATE condition has occurred. This setting will not prevent an update issued by the Command bit field.

Bit 0 – DIR Counter Direction

Normally this bit is controlled in hardware by the Waveform Generation mode or by event actions, but can also be changed from the software.

Value	Description
0	The counter is counting up (incrementing)
1	The counter is counting down (decrementing)

21.5.6 Control Register E Set - Normal Mode

Name: CTRLESET
Offset: 0x05
Reset: 0x00
Property: -

Use this register instead of a Read-Modify-Write (RMW) to set individual bits by writing a '1' to its bit location.

	7	6	5	4	3	2	1	0
					CMD[1:0]		LUPD	DIR
Access					R/W	R/W	R/W	R/W
Reset					0	0	0	0

Bits 3:2 – CMD[1:0] Command

This bit field is used for software control of update, restart, and Reset of the timer/counter. The command bit field is always read as '0'.

Value	Name	Description
0x0	NONE	No command
0x1	UPDATE	Force update
0x2	RESTART	Force restart
0x3	RESET	Force hard Reset (ignored if the timer/counter is enabled)

Bit 1 – LUPD Lock Update

Locking the update ensures that all buffers are valid before an update is performed.

Value	Description
0	The buffered registers are updated as soon as an UPDATE condition has occurred
1	No update of the buffered registers is performed, even though an UPDATE condition has occurred. This setting will not prevent an update issued by the Command bit field.

Bit 0 – DIR Counter Direction

Normally this bit is controlled in hardware by the Waveform Generation mode or by event actions, but can also be changed from the software.

Value	Description
0	The counter is counting up (incrementing)
1	The counter is counting down (decrementing)

21.5.7 Control Register F Clear

Name: CTRLFCLR
Offset: 0x06
Reset: 0x00
Property: -

Use this register instead of a Read-Modify-Write (RMW) to clear individual bits by writing a '1' to its bit location.

	7	6	5	4	3	2	1	0
					CMP2BV	CMP1BV	CMP0BV	PERBV
Access					R/W	R/W	R/W	R/W
Reset					0	0	0	0

Bit 3 – CMP2BV Compare 2 Buffer Valid
See CMP0BV.

Bit 2 – CMP1BV Compare 1 Buffer Valid
See CMP0BV.

Bit 1 – CMP0BV Compare 0 Buffer Valid
The CMPnBV bits are set when a new value is written to the corresponding TCAn.CMPnBUF register. These bits are automatically cleared on an UPDATE condition.

Bit 0 – PERBV Period Buffer Valid
This bit is set when a new value is written to the TCAn.PERBUF register. This bit is automatically cleared on an UPDATE condition.

21.5.8 Control Register F Set

Name: CTRLFSET
Offset: 0x07
Reset: 0x00
Property: -

Use this register instead of a Read-Modify-Write (RMW) to set individual bits by writing a '1' to its bit location.

	7	6	5	4	3	2	1	0
					CMP2BV	CMP1BV	CMP0BV	PERBV
Access					R/W	R/W	R/W	R/W
Reset					0	0	0	0

Bit 3 – CMP2BV Compare 2 Buffer Valid
See CMP0BV.

Bit 2 – CMP1BV Compare 1 Buffer Valid
See CMP0BV.

Bit 1 – CMP0BV Compare 0 Buffer Valid
The CMPnBV bits are set when a new value is written to the corresponding TCAn.CMPnBUF register. These bits are automatically cleared on an UPDATE condition.

Bit 0 – PERBV Period Buffer Valid
This bit is set when a new value is written to the TCAn.PERBUF register. This bit is automatically cleared on an UPDATE condition.

21.5.9 Event Control

Name: EVCTRL
Offset: 0x09
Reset: 0x00
Property: -

	Bit	7	6	5	4	3	2	1	0
		EVACTB[2:0]			CNTBEI	EVACTA[2:0]			CNTAEI
Access		R/W	R/W	R/W	R/W	R/W	R/W	R/W	R/W
Reset		0	0	0	0	0	0	0	0

Bits 7:5 – EVACTB[2:0] Event Action B

These bits define what action the counter will take upon certain event conditions.

Value	Name	Description
0x0	NONE	No action
0x1	-	Reserved
0x2	-	Reserved
0x3	UPDOWN	Counts the prescaled clock cycles or counts the matching events according to the setting for event input A. The event signal controls the count direction, up when low and down when high. The direction is latched when the counter counts.
0x4	RESTART_POSEDGE	Restart counter on positive event edge
0x5	RESTART_ANYEDGE	Restart counter on any event edge
0x6	RESTART_HIGHLVL	Restart counter while the event signal is high
Other	-	Reserved

Bit 4 – CNTBEI Enable Counter Event Input B

Value	Description
0	Counter Event input B is disabled
1	Counter Event input B is enabled according to EVACTB bit field

Bits 3:1 – EVACTA[2:0] Event Action A

These bits define what action the counter will take upon certain event conditions.

Value	Name	Description
0x0	CNT_POSEDGE	Count on positive event edge
0x1	CNT_ANYEDGE	Count on any event edge
0x2	CNT_HIGHLVL	Count prescaled clock cycles while the event signal is high
0x3	UPDOWN	Count prescaled clock cycles. The event signal controls the count direction, up when low and down when high. The direction is latched when the counter counts.
Other		Reserved

Bit 0 – CNTAEI Enable Counter Event Input A

Value	Description
0	Counter Event input A is disabled
1	Counter Event input A is enabled according to EVACTA bit field

21.5.10 Interrupt Control Register - Normal Mode

Name: INTCTRL
Offset: 0x0A
Reset: 0x00
Property: -

	7	6	5	4	3	2	1	0
		CMP2	CMP1	CMP0				OVF
Access		R/W	R/W	R/W				R/W
Reset		0	0	0				0

Bit 6 – CMP2 Compare Channel 2 Interrupt Enable
 See CMP0.

Bit 5 – CMP1 Compare Channel 1 Interrupt Enable
 See CMP0.

Bit 4 – CMP0 Compare Channel 0 Interrupt Enable
 Writing the CMPn bit to '1' enables the interrupt from Compare Channel n.

Bit 0 – OVF Timer Overflow/Underflow Interrupt Enable
 Writing the OVF bit to '1' enables the overflow/underflow interrupt.

21.5.11 Interrupt Flag Register - Normal Mode

Name: INTFLAGS
Offset: 0x0B
Reset: 0x00
Property: -

	7	6	5	4	3	2	1	0
Bit	CMP2		CMP1	CMP0				OVF
Access	R/W		R/W	R/W				R/W
Reset	0		0	0				0

Bit 6 – CMP2 Compare Channel 2 Interrupt Flag
 See the CMP0 flag description.

Bit 5 – CMP1 Compare Channel 1 Interrupt Flag
 See the CMP0 flag description.

Bit 4 – CMP0 Compare Channel 0 Interrupt Flag
 The Compare Interrupt (CMPn) flag is set on a compare match on the corresponding compare channel. For all modes of operation, the CMPn flag will be set when a compare match occurs between the Count (TCA_n.CNT) register and the corresponding Compare n (TCA_n.CMPn) register. The CMPn flag is not cleared automatically. It will be cleared only by writing a '1' to its bit location.

Bit 0 – OVF Overflow/Underflow Interrupt Flag
 This flag is set either on a TOP (overflow) or BOTTOM (underflow) condition, depending on the WGMODE setting. The OVF flag is not cleared automatically. It will be cleared only by writing a '1' to its bit location.

21.5.12 Debug Control Register - Normal Mode

Name: DBGCTRL
Offset: 0x0E
Reset: 0x00
Property: -

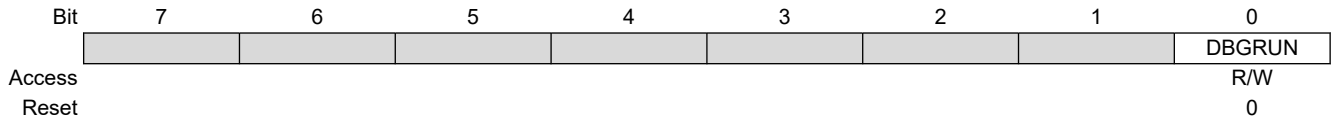

Bit 0 – DBGRUN Run in Debug

Value	Description
0	The peripheral is halted in Break Debug mode and ignores events
1	The peripheral will continue to run in Break Debug mode when the CPU is halted

21.5.13 Temporary Bits for 16-Bit Access

Name: TEMP
Offset: 0x0F
Reset: 0x00
Property: -

The Temporary register is used by the CPU for 16-bit single-cycle access to the 16-bit registers of this peripheral. The register is common for all the 16-bit registers of this peripheral and can be read and written by software. For more details on reading and writing 16-bit registers, refer to *Accessing 16-Bit Registers* in the *AVR CPU* section.

Bit	7	6	5	4	3	2	1	0
	TEMP[7:0]							
Access	R/W	R/W	R/W	R/W	R/W	R/W	R/W	R/W
Reset	0	0	0	0	0	0	0	0

Bits 7:0 – TEMP[7:0] Temporary Bits for 16-bit Access

21.5.14 Counter Register - Normal Mode

Name: CNT
Offset: 0x20
Reset: 0x00
Property: -

The TCA_n.CNTL and TCA_n.CNTH register pair represents the 16-bit value, TCA_n.CNT. The low byte [7:0] (suffix L) is accessible at the original offset. The high byte [15:8] (suffix H) can be accessed at offset + 0x01.

	Bit	15	14	13	12	11	10	9	8
		CNT[15:8]							
Access		R/W	R/W	R/W	R/W	R/W	R/W	R/W	R/W
Reset		0	0	0	0	0	0	0	0
	Bit	7	6	5	4	3	2	1	0
		CNT[7:0]							
Access		R/W	R/W	R/W	R/W	R/W	R/W	R/W	R/W
Reset		0	0	0	0	0	0	0	0

Bits 15:8 – CNT[15:8] Counter High Byte
 This bit field holds the MSB of the 16-bit Counter register.

Bits 7:0 – CNT[7:0] Counter Low Byte
 This bit field holds the LSB of the 16-bit Counter register.

21.5.15 Period Register - Normal Mode

Name: PER
Offset: 0x26
Reset: 0xFFFF
Property: -

The TCA_n.PER register contains the 16-bit TOP value in the timer/counter in all modes of operation, except Frequency Waveform Generation (FRQ).

The TCA_n.PERL and TCA_n.PERH register pair represents the 16-bit value, TCA_n.PER. The low byte [7:0] (suffix L) is accessible at the original offset. The high byte [15:8] (suffix H) can be accessed at offset + 0x01.

Bit	15	14	13	12	11	10	9	8
	PER[15:8]							
Access	R/W	R/W	R/W	R/W	R/W	R/W	R/W	R/W
Reset	1	1	1	1	1	1	1	1
Bit	7	6	5	4	3	2	1	0
	PER[7:0]							
Access	R/W	R/W	R/W	R/W	R/W	R/W	R/W	R/W
Reset	1	1	1	1	1	1	1	1

Bits 15:8 – PER[15:8] Periodic High Byte
 This bit field holds the MSB of the 16-bit Period register.

Bits 7:0 – PER[7:0] Periodic Low Byte
 This bit field holds the LSB of the 16-bit Period register.

21.5.16 Compare n Register - Normal Mode

Name: CMPn
Offset: 0x28 + n*0x02 [n=0..2]
Reset: 0x00
Property: -

This register is continuously compared to the counter value. Normally, the outputs from the comparators are used to generate waveforms.

The TCA_n.CMP_n registers are updated with the buffer value from their corresponding TCA_n.CMP_nBUF register when an UPDATE condition occurs.

The TCA_n.CMP_nL and TCA_n.CMP_nH register pair represents the 16-bit value, TCA_n.CMP_n. The low byte [7:0] (suffix L) is accessible at the original offset. The high byte [15:8] (suffix H) can be accessed at offset + 0x01.

	Bit	15	14	13	12	11	10	9	8
		CMP[15:8]							
Access		R/W	R/W	R/W	R/W	R/W	R/W	R/W	R/W
Reset		0	0	0	0	0	0	0	0
	Bit	7	6	5	4	3	2	1	0
		CMP[7:0]							
Access		R/W	R/W	R/W	R/W	R/W	R/W	R/W	R/W
Reset		0	0	0	0	0	0	0	0

Bits 15:8 – CMP[15:8] Compare High Byte
 This bit field holds the MSB of the 16-bit Compare register.

Bits 7:0 – CMP[7:0] Compare Low Byte
 This bit field holds the LSB of the 16-bit Compare register.

21.5.17 Period Buffer Register

Name: PERBUF
Offset: 0x36
Reset: 0xFFFF
Property: -

This register serves as the buffer for the Period (TCAn.PER) register. Writing to this register from the CPU or UPDI will set the Period Buffer Valid (PERBV) bit in the TCAn.CTRLF register.

The TCAn.PERBUFL and TCAn.PERBUFH register pair represents the 16-bit value, TCAn.PERBUF. The low byte [7:0] (suffix L) is accessible at the original offset. The high byte [15:8] (suffix H) can be accessed at offset + 0x01.

	Bit	15	14	13	12	11	10	9	8
		PERBUF[15:8]							
Access		R/W	R/W	R/W	R/W	R/W	R/W	R/W	R/W
Reset		1	1	1	1	1	1	1	1
	Bit	7	6	5	4	3	2	1	0
		PERBUF[7:0]							
Access		R/W	R/W	R/W	R/W	R/W	R/W	R/W	R/W
Reset		1	1	1	1	1	1	1	1

Bits 15:8 – PERBUF[15:8] Period Buffer High Byte
 This bit field holds the MSB of the 16-bit Period Buffer register.

Bits 7:0 – PERBUF[7:0] Period Buffer Low Byte
 This bit field holds the LSB of the 16-bit Period Buffer register.

21.5.18 Compare n Buffer Register

Name: CMPnBUF
Offset: 0x38 + n*0x02 [n=0..2]
Reset: 0x00
Property: -

This register serves as the buffer for the associated Compare n (TCAn.CMPn) register. Writing to this register from the CPU or UPDI will set the Compare Buffer valid (CMPnBV) bit in the TCAn.CTRLF register.

The TCAn.CMPnBUFL and TCAn.CMPnBUFH register pair represents the 16-bit value, TCAn.CMPnBUF. The low byte [7:0] (suffix L) is accessible at the original offset. The high byte [15:8] (suffix H) can be accessed at offset + 0x01.

	Bit	15	14	13	12	11	10	9	8
		CMPBUF[15:8]							
Access		R/W	R/W	R/W	R/W	R/W	R/W	R/W	R/W
Reset		0	0	0	0	0	0	0	0
	Bit	7	6	5	4	3	2	1	0
		CMPBUF[7:0]							
Access		R/W	R/W	R/W	R/W	R/W	R/W	R/W	R/W
Reset		0	0	0	0	0	0	0	0

Bits 15:8 – CMPBUF[15:8] Compare High Byte
 This bit field holds the MSB of the 16-bit Compare Buffer register.

Bits 7:0 – CMPBUF[7:0] Compare Low Byte
 This bit field holds the LSB of the 16-bit Compare Buffer register.

21.6 Register Summary - Split Mode

Offset	Name	Bit Pos.	7	6	5	4	3	2	1	0	
0x00	CTRLA	7:0	RUNSTDBY					CLKSEL[2:0]		ENABLE	
0x01	CTRLB	7:0		HCMP2EN	HCMP1EN	HCMP0EN		LCMP2EN	LCMP1EN	LCMP0EN	
0x02	CTRLC	7:0		HCMP2OV	HCMP1OV	HCMP0OV		LCMP2OV	LCMP1OV	LCMP0OV	
0x03	CTRLD	7:0								SPLITM	
0x04	CTRLECLR	7:0					CMD[1:0]		CMDEN[1:0]		
0x05	CTRLESET	7:0					CMD[1:0]		CMDEN[1:0]		
0x06	Reserved										
...											
0x09											
0x0A	INTCTRL	7:0		LCMP2	LCMP1	LCMP0			HUNF	LUNF	
0x0B	INTFLAGS	7:0		LCMP2	LCMP1	LCMP0			HUNF	LUNF	
0x0C	Reserved										
...											
0x0D											
0x0E	DBGCTRL	7:0								DBGRUN	
0x0F	Reserved										
...											
0x1F											
0x20	LCNT	7:0	LCNT[7:0]								
0x21	HCNT	7:0	HCNT[7:0]								
0x22	Reserved										
...											
0x25											
0x26	LPER	7:0	LPER[7:0]								
0x27	HPER	7:0	HPER[7:0]								
0x28	LCMP0	7:0	LCMP[7:0]								
0x29	HCMP0	7:0	HCMP[7:0]								
0x2A	LCMP1	7:0	LCMP[7:0]								
0x2B	HCMP1	7:0	HCMP[7:0]								
0x2C	LCMP2	7:0	LCMP[7:0]								
0x2D	HCMP2	7:0	HCMP[7:0]								

21.7 Register Description - Split Mode

21.7.1 Control A - Split Mode

Name: CTRLA
Offset: 0x00
Reset: 0x00
Property: -

	7	6	5	4	3	2	1	0
	RUNSTDBY					CLKSEL[2:0]		ENABLE
Access	R/W				R/W	R/W	R/W	R/W
Reset	0				0	0	0	0

Bit 7 – RUNSTDBY Run Standby

Writing a '1' to this bit will enable the peripheral to run in Standby sleep mode.

Bits 3:1 – CLKSEL[2:0] Clock Select

These bits select the clock frequency for the timer/counter.

Value	Name	Description
0x0	DIV1	$f_{TCA} = f_{CLK_PER}$
0x1	DIV2	$f_{TCA} = f_{CLK_PER}/2$
0x2	DIV4	$f_{TCA} = f_{CLK_PER}/4$
0x3	DIV8	$f_{TCA} = f_{CLK_PER}/8$
0x4	DIV16	$f_{TCA} = f_{CLK_PER}/16$
0x5	DIV64	$f_{TCA} = f_{CLK_PER}/64$
0x6	DIV256	$f_{TCA} = f_{CLK_PER}/256$
0x7	DIV1024	$f_{TCA} = f_{CLK_PER}/1024$

Bit 0 – ENABLE Enable

Value	Description
0	The peripheral is disabled
1	The peripheral is enabled

21.7.2 Control B - Split Mode

Name: CTRLB
Offset: 0x01
Reset: 0x00
Property: -

	7	6	5	4	3	2	1	0
		HCMP2EN	HCMP1EN	HCMP0EN		LCMP2EN	LCMP1EN	LCMP0EN
Access		R/W	R/W	R/W		R/W	R/W	R/W
Reset		0	0	0		0	0	0

Bit 6 – HCMP2EN High byte Compare 2 Enable
 See HCMP0EN.

Bit 5 – HCMP1EN High byte Compare 1 Enable
 See HCMP0EN.

Bit 4 – HCMP0EN High byte Compare 0 Enable
 Setting the HCMPnEN bit in the FRQ or PWM Waveform Generation mode of operation will override the port output register for the corresponding WO[n+3] pin.

Bit 2 – LCMP2EN Low byte Compare 2 Enable
 See LCMP0EN.

Bit 1 – LCMP1EN Low byte Compare 1 Enable
 See LCMP0EN.

Bit 0 – LCMP0EN Low byte Compare 0 Enable
 Setting the LCMPnEN bit in the FRQ or PWM Waveform Generation mode of operation will override the port output register for the corresponding WOn pin.

21.7.3 Control C - Split Mode

Name: CTRLC
Offset: 0x02
Reset: 0x00
Property: -

	7	6	5	4	3	2	1	0
Access		HCMP2OV	HCMP1OV	HCMP0OV		LCMP2OV	LCMP1OV	LCMP0OV
Reset		R/W	R/W	R/W		R/W	R/W	R/W
		0	0	0		0	0	0

Bit 6 – HCMP2OV High byte Compare 2 Output Value
 See HCMP0OV.

Bit 5 – HCMP1OV High byte Compare 1 Output Value
 See HCMP0OV.

Bit 4 – HCMP0OV High byte Compare 0 Output Value
 The HCMPnOV bit allows direct access to the output compare value of the waveform generator when the timer/counter is not enabled. This is used to set or clear the WO[n+3] output value when the timer/counter is not running.

Bit 2 – LCMP2OV Low byte Compare 2 Output Value
 See LCMP0OV.

Bit 1 – LCMP1OV Low byte Compare 1 Output Value
 See LCMP0OV.

Bit 0 – LCMP0OV Low byte Compare 0 Output Value
 The LCMPnOV bit allows direct access to the output compare value of the waveform generator when the timer/counter is not enabled. This is used to set or clear the WOn output value when the timer/counter is not running.

Note: When the output is connected to the pad, overriding these bits will not work unless the xCMPnEN bits in the TCA_n.CTRLB register have been set. If the output is connected to CCL, the xCMPnEN bits in the TCA_n.CTRLB register are bypassed.

21.7.4 Control D - Split Mode

Name: CTRLD
Offset: 0x03
Reset: 0x00
Property: -

Bit	7	6	5	4	3	2	1	0
								SPLITM
Access								R/W
Reset								0

Bit 0 – SPLITM Enable Split Mode

This bit sets the timer/counter in Split mode operation and will work as two 8-bit timer/counters. The register map will change compared to the normal 16-bit mode.

21.7.5 Control Register E Clear - Split Mode

Name: CTRLECLR
Offset: 0x04
Reset: 0x00
Property: -

Use this register instead of a Read-Modify-Write (RMW) to clear individual bits by writing a '1' to its bit location.

	7	6	5	4	3	2	1	0
					CMD[1:0]		CMDEN[1:0]	
Access					R/W	R/W	R/W	R/W
Reset					0	0	0	0

Bits 3:2 – CMD[1:0] Command

This bit field is used for software control of restart and reset of the timer/counter. The command bit field is always read as '0'.

Value	Name	Description
0x0	NONE	No command
0x1	-	Reserved
0x2	RESTART	Force restart
0x3	RESET	Force hard Reset (ignored if the timer/counter is enabled)

Bits 1:0 – CMDEN[1:0] Command Enable

This bit field configures what timer/counters the command given by the CMD-bits will be applied to.

Value	Name	Description
0x0	NONE	None
0x1	-	Reserved
0x2	-	Reserved
0x3	BOTH	Command (CMD) will be applied to both low byte and high byte timer/counter

21.7.6 Control Register E Set - Split Mode

Name: CTRLRESET
Offset: 0x05
Reset: 0x00
Property: -

Use this register instead of a Read-Modify-Write (RMW) to set individual bits by writing a '1' to its bit location.

	7	6	5	4	3	2	1	0
					CMD[1:0]		CMDEN[1:0]	
Access					R/W	R/W	R/W	R/W
Reset					0	0	0	0

Bits 3:2 – CMD[1:0] Command

This bit field is used for software control of restart and reset of the timer/counter. The command bit field is always read as '0'. The CMD bit field must be used together with the Command Enable (CMDEN) bits. Using the RESET command requires that both low byte and high byte timer/counter are selected with CMDEN.

Value	Name	Description
0x0	NONE	No command
0x1	-	Reserved
0x2	RESTART	Force restart
0x3	RESET	Force hard Reset (ignored if the timer/counter is enabled)

Bits 1:0 – CMDEN[1:0] Command Enable

This bit field configures what timer/counters the command given by the CMD-bits will be applied to.

Value	Name	Description
0x0	NONE	None
0x1	-	Reserved
0x2	-	Reserved
0x3	BOTH	Command (CMD) will be applied to both low byte and high byte timer/counter

21.7.7 Interrupt Control Register - Split Mode

Name: INTCTRL
Offset: 0x0A
Reset: 0x00
Property: -

	7	6	5	4	3	2	1	0
		LCMP2	LCMP1	LCMP0			HUNF	LUNF
Access		R/W	R/W	R/W			R/W	R/W
Reset		0	0	0			0	0

Bit 6 – LCMP2 Low byte Compare Channel 2 Interrupt Enable
 See LCMP0.

Bit 5 – LCMP1 Low byte Compare Channel 1 Interrupt Enable
 See LCMP0.

Bit 4 – LCMP0 Low byte Compare Channel 0 Interrupt Enable
 Writing the LCMPn bit to '1' enables the low byte Compare Channel n interrupt.

Bit 1 – HUNF High byte Underflow Interrupt Enable
 Writing the HUNF bit to '1' enables the high byte underflow interrupt.

Bit 0 – LUNF Low byte Underflow Interrupt Enable
 Writing the LUNF bit to '1' enables the low byte underflow interrupt.

21.7.8 Interrupt Flag Register - Split Mode

Name: INTFLAGS
Offset: 0x0B
Reset: 0x00
Property: -

	7	6	5	4	3	2	1	0
Bit		LCMP2	LCMP1	LCMP0			HUNF	LUNF
Access		R/W	R/W	R/W			R/W	R/W
Reset		0	0	0			0	0

Bit 6 – LCMP2 Low byte Compare Channel 2 Interrupt Flag
 See LCMP0 flag description.

Bit 5 – LCMP1 Low byte Compare Channel 1 Interrupt Flag
 See LCMP0 flag description.

Bit 4 – LCMP0 Low byte Compare Channel 0 Interrupt Flag
 The Low byte Compare Interrupt (LCMPn) flag is set on a compare match on the corresponding compare channel in the low byte timer.
 For all modes of operation, the LCMPn flag will be set when a compare match occurs between the Low Byte Timer Counter (TCA_n.LCNT) register and the corresponding Compare n (TCA_n.LCMPn) register. The LCMPn flag will not be cleared automatically and has to be cleared by software. This is done by writing a '1' to its bit location.

Bit 1 – HUNF High byte Underflow Interrupt Flag
 This flag is set on a high byte timer BOTTOM (underflow) condition. HUNF is not automatically cleared and needs to be cleared by software. This is done by writing a '1' to its bit location.

Bit 0 – LUNF Low byte Underflow Interrupt Flag
 This flag is set on a low byte timer BOTTOM (underflow) condition. LUNF is not automatically cleared and needs to be cleared by software. This is done by writing a '1' to its bit location.

21.7.9 Debug Control Register - Split Mode

Name: DBGCTRL
Offset: 0x0E
Reset: 0x00
Property: -

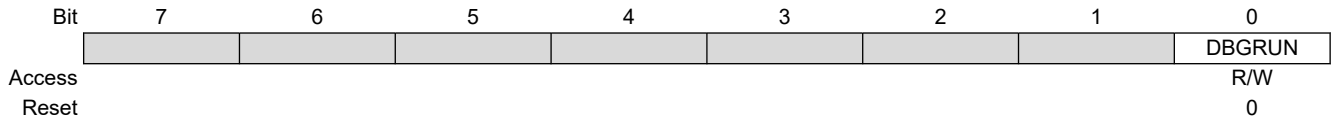

Bit 0 – DBGRUN Run in Debug

Value	Description
0	The peripheral is halted in Break Debug mode and ignores events
1	The peripheral will continue to run in Break Debug mode when the CPU is halted

21.7.10 Low Byte Timer Counter Register - Split Mode

Name: LCNT
Offset: 0x20
Reset: 0x00
Property: -

The TCA_n.LCNT register contains the counter value for the low byte timer. CPU and UPDI write access has priority over count, clear or reload of the counter.

Bit	7	6	5	4	3	2	1	0
	LCNT[7:0]							
Access	R/W	R/W	R/W	R/W	R/W	R/W	R/W	R/W
Reset	0	0	0	0	0	0	0	0

Bits 7:0 – LCNT[7:0] Counter Value for Low Byte Timer
 This bit field defines the counter value of the low byte timer.

21.7.11 High Byte Timer Counter Register - Split Mode

Name: HCNT
Offset: 0x21
Reset: 0x00
Property: -

The TCA_n.HCNT register contains the counter value for the high byte timer. CPU and UPDI write access has priority over count, clear or reload of the counter.

Bit	7	6	5	4	3	2	1	0
	HCNT[7:0]							
Access	R/W	R/W	R/W	R/W	R/W	R/W	R/W	R/W
Reset	0	0	0	0	0	0	0	0

Bits 7:0 – HCNT[7:0] Counter Value for High Byte Timer
 This bit field defines the counter value in high byte timer.

21.7.12 Low Byte Timer Period Register - Split Mode

Name: LPER
Offset: 0x26
Reset: 0xFF
Property: -

The TCAn.LPER register contains the TOP value for the low byte timer.

Bit	7	6	5	4	3	2	1	0
	LPER[7:0]							
Access	R/W	R/W	R/W	R/W	R/W	R/W	R/W	R/W
Reset	1	1	1	1	1	1	1	1

Bits 7:0 – LPER[7:0] Period Value Low Byte Timer
This bit field holds the TOP value for the low byte timer.

21.7.13 High Byte Period Register - Split Mode

Name: HPER
Offset: 0x27
Reset: 0xFF
Property: -

The TCA_n.HPER register contains the TOP value for the high byte timer.

	7	6	5	4	3	2	1	0
	HPER[7:0]							
Access	R/W	R/W	R/W	R/W	R/W	R/W	R/W	R/W
Reset	1	1	1	1	1	1	1	1

Bits 7:0 – HPER[7:0] Period Value High Byte Timer
 This bit field holds the TOP value for the high byte timer.

21.7.14 Compare Register n For Low Byte Timer - Split Mode

Name: LCMPn
Offset: 0x28 + n*0x02 [n=0..2]
Reset: 0x00
Property: -

The TCAn.LCMPn register represents the compare value of Compare Channel n for the low byte timer. This register is continuously compared to the counter value of the low byte timer, TCAn.LCNT. Normally, the outputs from the comparators are then used to generate waveforms.

Bit	7	6	5	4	3	2	1	0
	LCMP[7:0]							
Access	R/W	R/W	R/W	R/W	R/W	R/W	R/W	R/W
Reset	0	0	0	0	0	0	0	0

Bits 7:0 – LCMP[7:0] Compare Value of Channel n
 This bit field holds the compare value of channel n that is compared to TCAn.LCNT.

21.7.15 High Byte Compare Register n - Split Mode

Name: HCMPn
Offset: 0x29 + n*0x02 [n=0..2]
Reset: 0x00
Property: -

The TCA_n.HCMP_n register represents the compare value of Compare Channel n for the high byte timer. This register is continuously compared to the counter value of the high byte timer, TCA_n.HCNT. Normally, the outputs from the comparators are then used to generate waveforms.

Bit	7	6	5	4	3	2	1	0
	HCMP[7:0]							
Access	R/W	R/W	R/W	R/W	R/W	R/W	R/W	R/W
Reset	0	0	0	0	0	0	0	0

Bits 7:0 – HCMP[7:0] Compare Value of Channel n
 This bit field holds the compare value of channel n that is compared to TCA_n.HCNT.

22. TCB - 16-Bit Timer/Counter Type B

22.1 Features

- 16-bit Counter Operation Modes:
 - Periodic interrupt
 - Time-out check
 - Input capture
 - On event
 - Frequency measurement
 - Pulse-width measurement
 - Frequency and pulse-width measurement
 - 32-bit capture
 - Single-shot
 - 8-bit Pulse-Width Modulation (PWM)
- Noise Canceler on Event Input
- Synchronize Operation with TCAn

22.2 Overview

The capabilities of the 16-bit Timer/Counter type B (TCB) include frequency and waveform generation and input capture on event with time and frequency measurement of digital signals. The TCB consists of a base counter and control logic that can be set in one of eight different modes, each mode providing unique functionality. The base counter is clocked by the peripheral clock with optional prescaling.

22.2.1 Block Diagram

Figure 22-1. Timer/Counter Type B Block Diagram

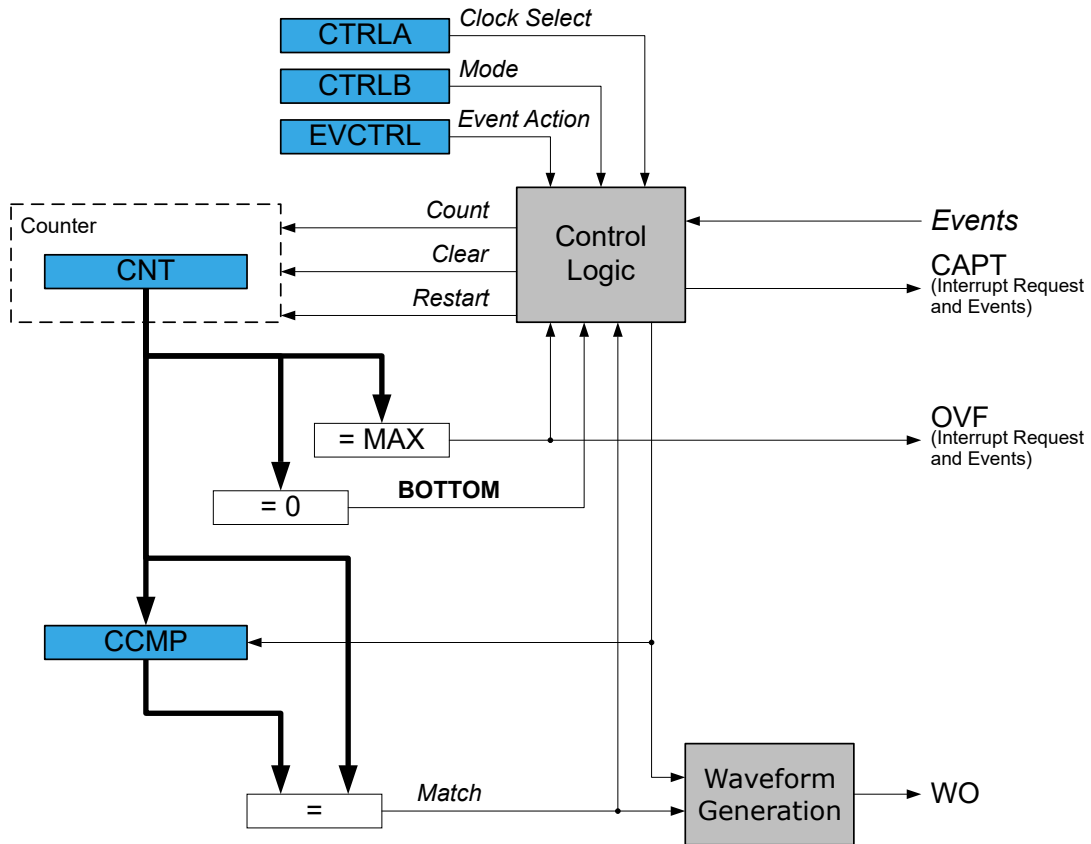

The timer/counter can be clocked from the Peripheral Clock (CLK_PER), from a 16-bit Timer/Counter type A (CLK_TCA_n) or the Event System (EVSYS).

Figure 22-2. Timer/Counter Clock Logic

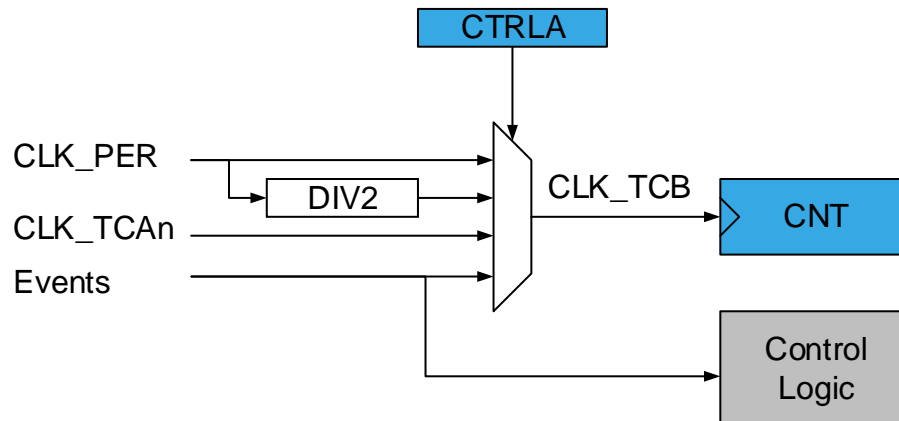

The Clock Select (CLKSEL) bit field in the Control A (TCBn.CTRLA) register selects one of the prescaler outputs directly, or an event channel as the clock (CLK_TCB) input.

Setting the timer/counter to use the clock from a TCAn allows the timer/counter to run in sync with that TCAn.

By using the EVSYS, any event source, such as an external clock signal on any I/O pin, may be used as the counter clock input or as a control logic input. When an event action controlled operation is used, the clock selection must be set to use an event channel as the counter input.

22.2.2 Signal Description

Signal	Description	Type
WO	Digital Asynchronous Output	Waveform Output

22.3 Functional Description

22.3.1 Definitions

The following definitions are used throughout the documentation:

Table 22-1. Timer/Counter Definitions

Name	Description
BOTTOM	The counter reaches BOTTOM when it becomes 0x0000
MAX	The counter reaches the maximum when it becomes 0xFFFF
TOP	The counter reaches TOP when it becomes equal to the highest value in the count sequence
CNT	Count (TCBn.CNT) register value
CCMP	Capture/Compare (TCBn.CCMP) register value

Note: In general, the term ‘timer’ is used when the timer/counter is counting periodic clock ticks. The term ‘counter’ is used when the input signal has sporadic or irregular ticks.

22.3.2 Initialization

By default, the TCB is in Periodic Interrupt mode. Follow these steps to start using it:

1. Write a TOP value to the Compare/Capture (TCBn.CCMP) register.
2. Optional: Write the Compare/Capture Output Enable (CCMPEN) bit in the Control B (TCBn.CTRLB) register to ‘1’. This will make the waveform output available on the corresponding pin, overriding the value in the corresponding PORT output register.
3. Enable the counter by writing a ‘1’ to the ENABLE bit in the Control A (TCBn.CTRLA) register. The counter will start counting clock ticks according to the prescaler setting in the Clock Select (CLKSEL) bit field in the Control A (TCBn.CTRLA) register.
4. The counter value can be read from the Count (TCBn.CNT) register. The peripheral will generate a CAPT interrupt and event when the CNT value reaches TOP.
 - a. If the Compare/Capture register is modified to a value lower than the current CNT, the peripheral will count to MAX and wrap around.
 - b. At MAX, an OVF interrupt and event will be generated.

22.3.3 Operation

22.3.3.1 Modes

The timer can be configured to run in one of the eight different modes described in the sections below. The event pulse needs to be longer than one system clock cycle to ensure edge detection.

22.3.3.1.1 Periodic Interrupt Mode

In the Periodic Interrupt mode, the counter counts to the capture value and restarts from BOTTOM. A CAPT interrupt and event is generated when the CNT is equal to TOP. If TOP is updated to a value lower than CNT, upon reaching MAX, an OVF interrupt and event is generated, and the counter restarts from BOTTOM.

Figure 22-3. Periodic Interrupt Mode

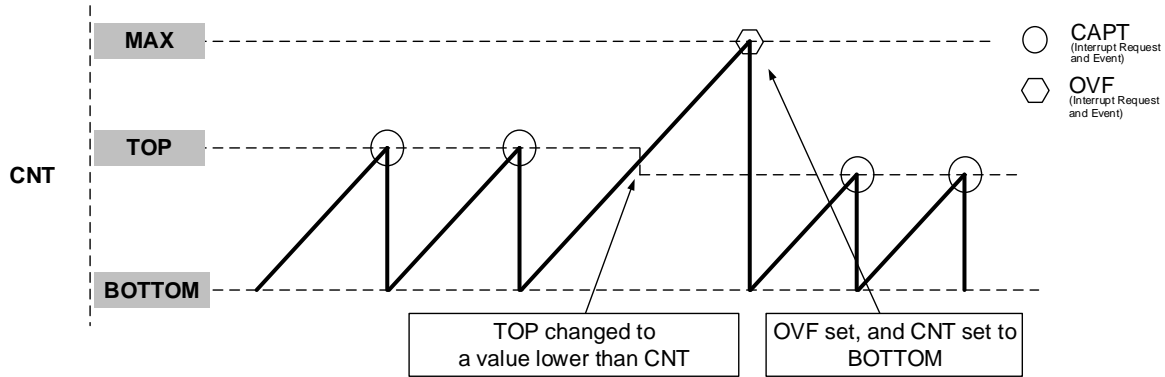

22.3.3.1.2 Time-Out Check Mode

In the Time-Out Check mode, the peripheral starts counting on the first signal edge and stops on the next signal edge detected on the event input channel. CNT remains stationary after the Stop edge (Freeze state). In Freeze state, the counter will restart on a new Start edge.

This mode requires TCB to be configured as an event user and is explained in the Events section.

Start or Stop edge is determined by the Event Edge (EDGE) bit in the Event Control (TCBn.EVCTRL) register. If CNT reaches TOP before the second edge, a CAPT interrupt and event will be generated. If TOP is updated to a value lower than the CNT upon reaching MAX, an OVF interrupt and the simultaneous event is generated, and the counter restarts from BOTTOM. In Freeze state, reading the Count (TCBn.CNT) register or Compare/Capture (TCBn.CCMP) register, or writing the Run (RUN) bit in the Status (TCBn.STATUS) register has no effect.

Figure 22-4. Time-Out Check Mode

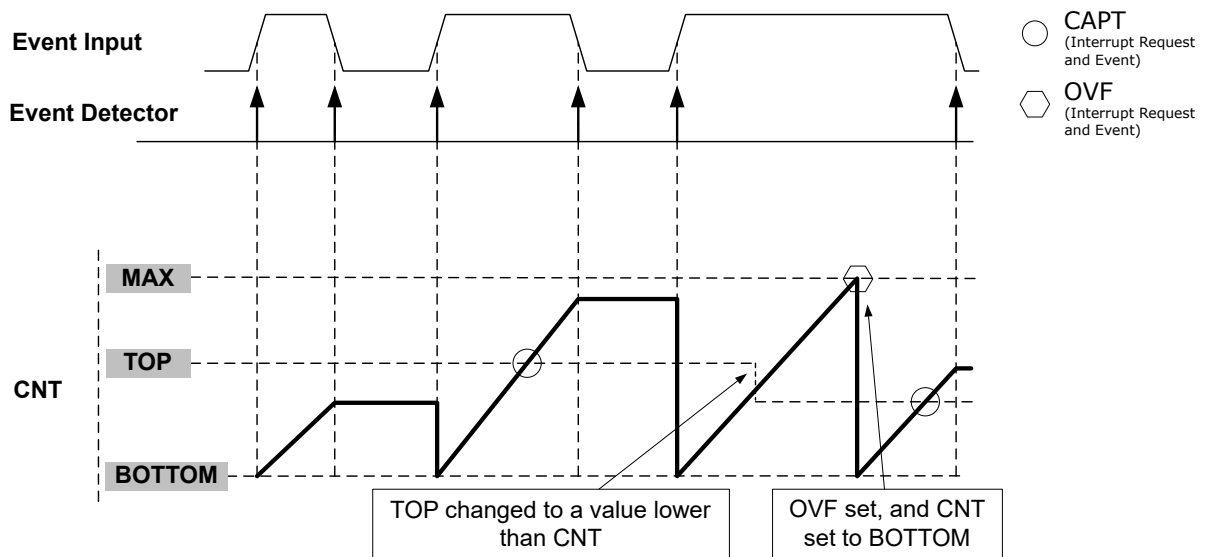

22.3.3.1.3 Input Capture on Event Mode

In the Input Capture on Event mode, the counter will count from BOTTOM to MAX continuously. When an event is detected the Count (TCBn.CNT) register value is transferred to the Compare/Capture (TCBn.CCMP) register and a CAPT interrupt and event is generated. The Event edge detector that can be configured to trigger a capture on either rising or falling edges.

This mode requires TCB to be configured as an event user and is explained in the Events section.

The figure below shows the input capture unit configured to capture on the falling edge of the event input signal. The CAPT Interrupt flag is automatically cleared after the low byte of the Compare/Capture (TCBn.CCMP) register has been read. An OVF interrupt and event is generated when the CNT is MAX.

Figure 22-5. Input Capture on Event

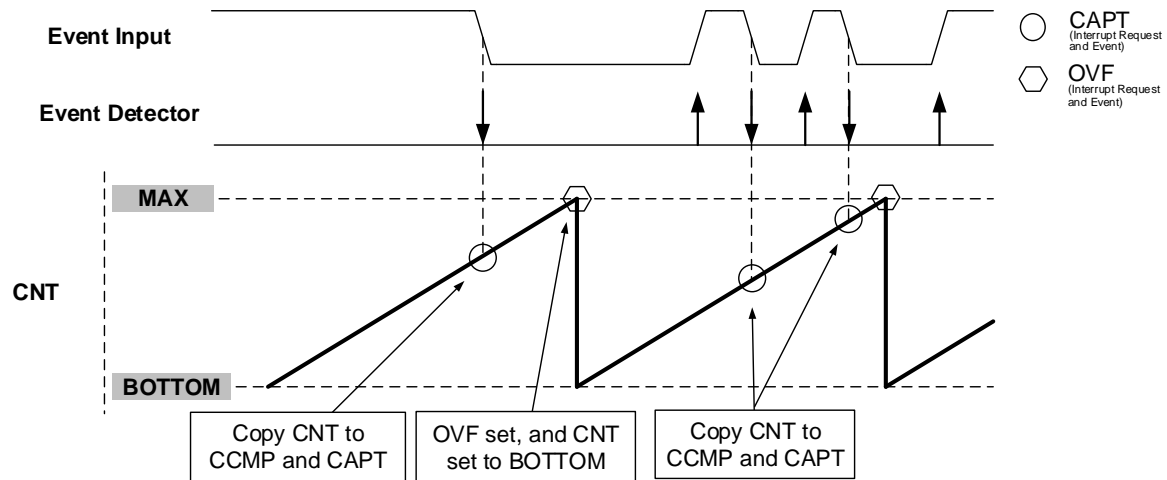

Important: It is recommended to write 0x0000 to the Count (TCBn.CNT) register when entering this mode from any other mode.

22.3.3.1.4 Input Capture Frequency Measurement Mode

In the Input Capture Frequency Measurement mode, the TCB captures the counter value and restarts on either a positive or negative edge of the event input signal.

The CAPT Interrupt flag is automatically cleared after the low byte of the Compare/Capture (TCBn.CCMP) register has been read. An OVF interrupt and event is generated when the CNT value is MAX.

This mode requires TCB to be configured as an event user and is explained in the Events section.

The figure below illustrates this mode when configured to act on a rising edge.

Figure 22-6. Input Capture Frequency Measurement

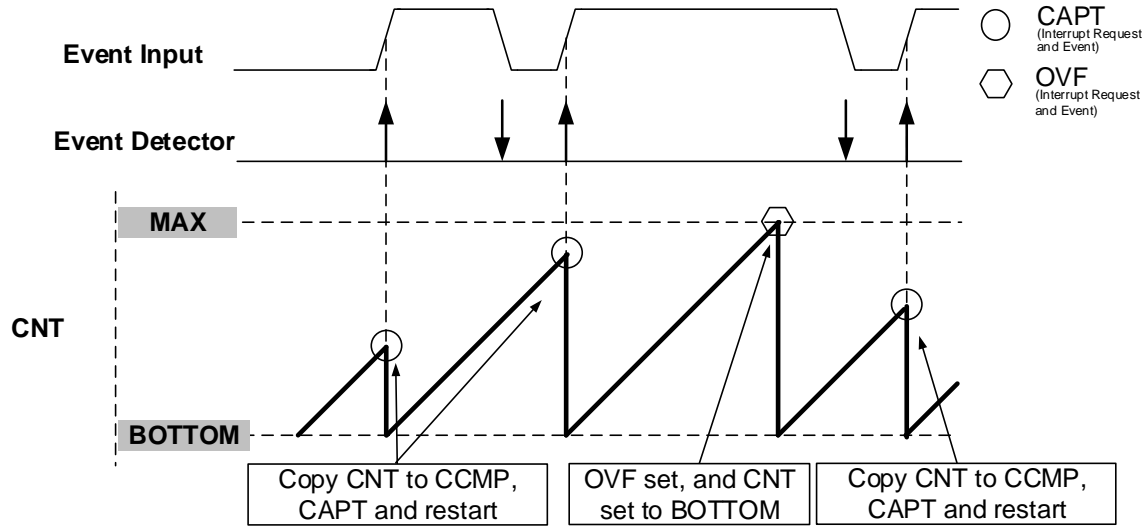

22.3.3.1.5 Input Capture Pulse-Width Measurement Mode

In the Input Capture Pulse-Width Measurement mode, the input capture pulse-width measurement will restart the counter on a positive edge, and capture on the next falling edge before an interrupt request is generated. The CAPT Interrupt flag is automatically cleared after the low byte of the Compare/Capture (TCBn.CCMP) register has been read. An OVF interrupt and event is generated when the CNT is MAX. The timer will automatically switch between rising and falling edge detection, but a minimum edge separation of two clock cycles is required for correct behavior.

This mode requires TCB to be configured as an event user and is explained in the Events section.

Figure 22-7. Input Capture Pulse-Width Measurement

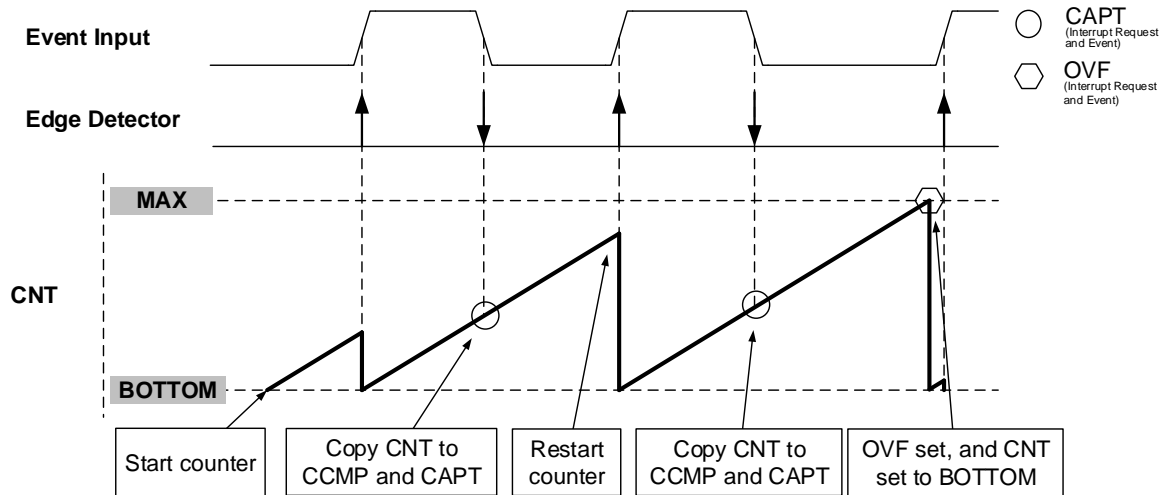

22.3.3.1.6 Input Capture Frequency and Pulse-Width Measurement Mode

In the Input Capture Frequency and Pulse-Width Measurement mode, the timer will start counting when a positive edge is detected on the event input signal. The count value is captured on the following falling edge. The counter stops when the second rising edge of the event input signal is detected. This will set the CAPT interrupt flag.

This mode requires TCB to be configured as an event user and is explained in the Events section.

The CAPT Interrupt flag is automatically cleared after the low byte of the Compare/Capture (TCBn.CCMP) register has been read, and the timer/counter is ready for a new capture sequence. Therefore, the Count (TCBn.CNT) register must be read before the Compare/Capture (TCBn.CCMP) register, since it is reset to BOTTOM at the next positive edge of the event input signal. An OVF interrupt and event is generated when the CNT value is MAX.

Figure 22-8. Input Capture Frequency and Pulse-Width Measurement

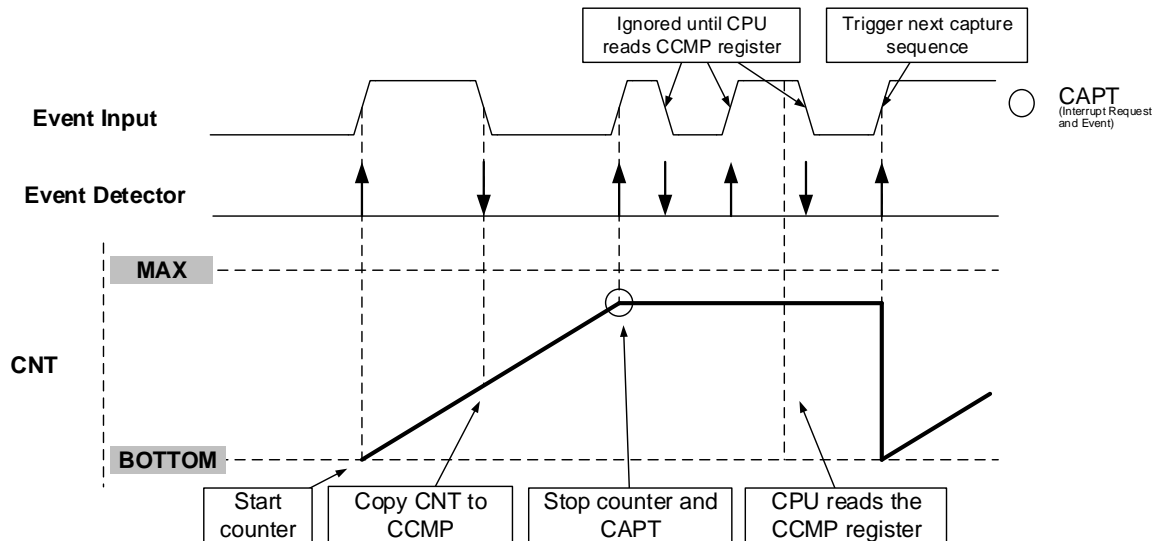

22.3.3.1.7 Single-Shot Mode

The Single-Shot mode can be used to generate a pulse with a duration defined by the Compare (TCBn.CCMP) register, every time a rising or falling edge is observed on a connected event channel.

This mode requires TCB to be configured as an event user and is explained in the Events section.

When the counter is stopped, the output pin is set low. If an event is detected on the connected event channel, the timer will reset and start counting from BOTTOM to TOP while driving its output high. The RUN bit in the Status (TCBn.STATUS) register can be read to see if the counter is counting or not. When CNT reaches the CCMP register value, the counter will stop, and the output pin will go low for at least one counter clock cycle (TCB_CLK), and a new event arriving during this time will be ignored. After this, there is a delay of two peripheral clock cycles (PER_CLK) from when a new event is received until the output is set high. When the EDGE bit of the TCB.EVCTRL register is written to '1', any edge can trigger the start of counter. If the EDGE bit is '0', only positive edges will trigger the start.

The counter will start counting as soon as the peripheral is enabled, even without triggering by an event, or if the Event Edge (EDGE) bit in the Event Control (TCBn.EVCTRL) register is modified while the peripheral is enabled. This is prevented by writing TOP to the Counter register. Similar behavior is seen if the Event Edge (EDGE) bit in the Event Control (TCBn.EVCTRL) register is '1' while the module is enabled. Writing TOP to the Counter register prevents this as well.

If the Event Asynchronous (ASYNC) bit in the Control B (TCBn.CTRLB) register is written to '1', the timer will react asynchronously to an incoming event. An edge on the event will immediately cause the output signal to be set. The counter will still start counting two clock cycles after the event is received.

Figure 22-9. Single-Shot Mode

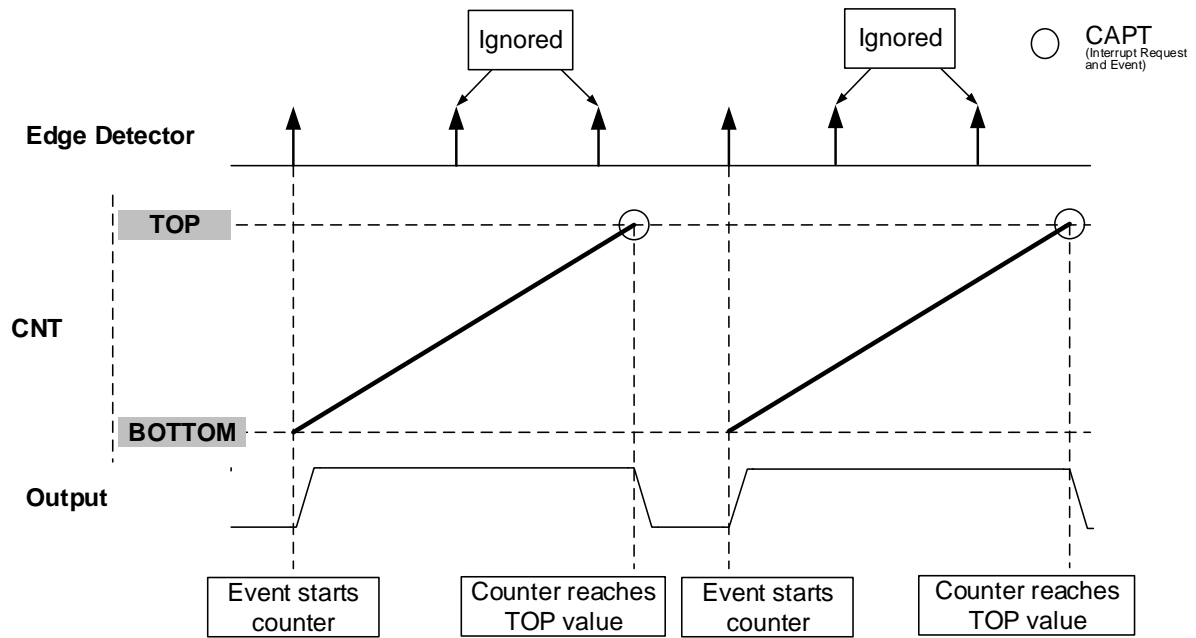

22.3.3.1.8 8-Bit PWM Mode

The TCB can be configured to run in 8-bit PWM mode, where each of the register pairs in the 16-bit Compare/Capture (TCBn.CCMPH and TCBn.CCMPL) register are used as individual Compare registers. The period (T) is controlled by CCMPL, while CCMPH controls the duty cycle of the waveform. The counter will continuously count from BOTTOM to CCMPL, and the output will be set at BOTTOM and cleared when the counter reaches CCMPH.

CCMPH is the number of cycles for which the output will be driven high. CCMPL+1 is the period of the output pulse.

Figure 22-10. 8-Bit PWM Mode

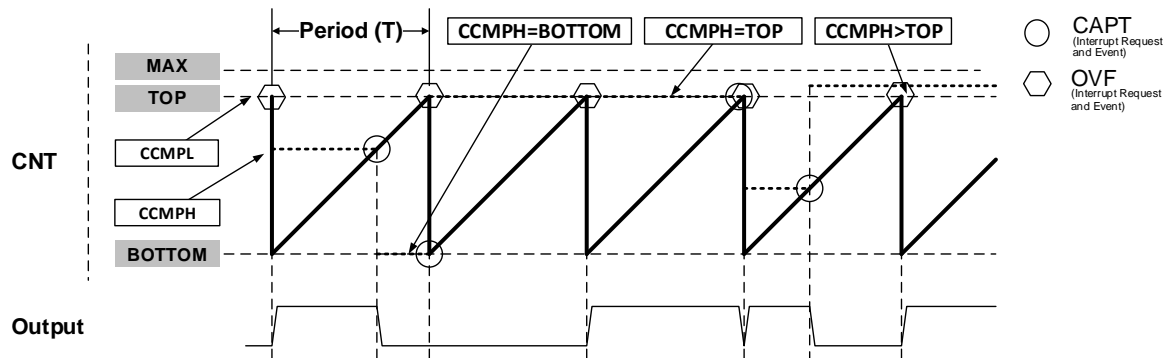

22.3.3.2 Output

Timer synchronization and output logic level are dependent on the selected Timer Mode (CNTMODE) bit field in Control B (TCBn.CTRLB) register. In Single-Shot mode, the timer/counter can be configured so that the signal generation happens asynchronously to an incoming event (ASYNC = 1 in TCBn.CTRLB). The output signal is then set immediately at the incoming event instead of being synchronized to the TCB clock. Even though the output is set immediately, it will take two to three CLK_TCB cycles before the counter starts counting.

Writing the Compare/Capture Output Enable (CCMPEN) bit in TCBn.CTRLB to '1' enables the waveform output. This will make the waveform output available on the corresponding pin, overriding the value in the corresponding PORT output register.

The different configurations and their impact on the output are listed in the table below.

Table 22-2. Output Configuration

CCMPEN	CNTMODE	ASYNC	Output
1	Single-Shot mode	0	The output is high when the <u>counter starts</u> , and the output is low when the counter stops
		1	The output is high when the <u>event arrives</u> , and the output is low when the counter stops
	8-bit PWM mode	Not applicable	8-bit PWM mode
	Other modes	Not applicable	The Compare/Capture Pin Initial Value bit (CCMPINIT) in the Control B (TCBn.CTRLB) register selects the initial output level
0	Not applicable	Not applicable	No output

It is not recommended to change modes while the peripheral is enabled, as this can produce an unpredictable output. There is a possibility that an interrupt flag is set during the timer configuration. It is recommended to clear the Timer/Counter Interrupt Flags (TCBn.INTFLAGS) register after configuring the peripheral.

22.3.3.3 32-Bit Input Capture

Two 16-bit Timer/Counter Type B (TCBn) can be combined to work as a true 32-bit input capture:

One TCB is counting the two LSBs. Once this counter reaches MAX, an overflow (OVF) event is generated, and the counter wraps around. The second TCB is configured to count these OVF events and thus provides the two MSBs. The 32-bit counter value is concatenated from the two counter values.

To function as a 32-bit counter, the two TCBs and the system have to be set up as described in the following paragraphs.

System Configuration

- Configure a source (TCA, events, CLK_PER) for the count input for the LSB TCB, according to the application requirements
- Configure the event system to route the OVF events from the LSB TCB (event generator) to the MSB TCB (event user)
- Configure the event system to route the same capture event (CAPT) generator to both TCBs

Configuration of the LSB Counter

- Select the configured count input by writing the Clock Select (CLKSEL) bit field in the Control A (CTRLA) register
- Write the Timer Mode (CNTMODE) bit field in the Control B (CTRLB) register to select one of the Input Capture modes
- The Cascade Two Timer/Counters (CASCADE) bit in CTRLA must be '0'

Configuration of the MSB Counter

- Enable the 32-bit mode by writing the Cascade Two Timer/Counters bit (CASCADE) in CTRLA to '1'
- Select events as clock input by writing to the Clock Select (CLKSEL) bit field in the Control A (CTRLA) register
- Write the Timer Mode (CNTMODE) bit field in the Control B (CTRLB) register to select the same Input Capture mode as the LSB TCB

Capturing a 32-Bit Counter Value

To acquire a 32-bit counter value, send a CAPT event to both TCBs. Both TCBs are running in the same capture mode, so each will capture the current counter value (CNT) in the respective Capture/Compare (CCMP) register. The 32-bit capture value is formed by concatenating the two CCMP registers.

Example 22-1. Using TCB0 as LSB Counter and TCB1 as MSB Counter

TCB0 is counting the count input, and TCB1 is counting the OVF signals from TCB0. Both TCBs are in Input Capture on Event mode.

A CAPT event is generated and causes both TCB0 and TCB1 to copy their current CNT values to their respective CCMP registers. The two different CASCADE bit values allow a correct timing of the CAPT event.

The captured 32-bit value is concatenated from TCB1.CCMP (MSB) and TCB0.CCMP (LSB).

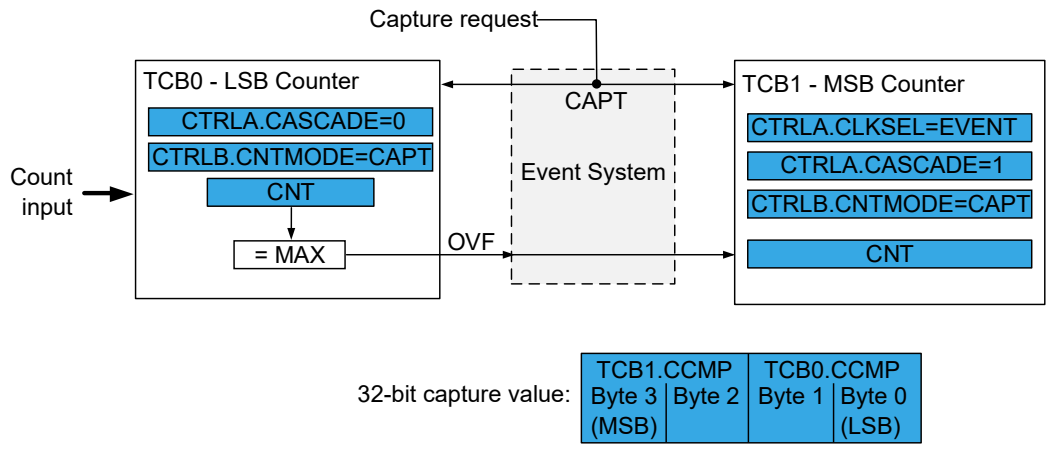

22.3.3.4 Noise Canceler

The Noise Canceler improves the noise immunity by using a simple digital filter scheme. When the Noise Filter (FILTER) bit in the Event Control (TCBn.EVCTRL) register is enabled, the peripheral monitors the event channel and keeps a record of the last four observed samples. If four consecutive samples are equal, the input is considered to be stable, and the signal is fed to the edge detector.

When enabled, the Noise Canceler introduces an additional delay of four peripheral clock cycles between a change applied to the input and the update of the Input Compare register.

The Noise Canceler uses the peripheral clock and is, therefore, not affected by the prescaler.

22.3.3.5 Synchronized with Timer/Counter Type A

The TCB can be configured to use the clock (CLK_TCA) of a Timer/Counter type A (TCAn) by writing to the Clock Select bit field (CLKSEL) in the Control A register (TCBn.CTRLA). In this setting, the TCB will count on the same clock source as selected in TCAn.

When the Synchronize Update (SYNCUPD) bit in the Control A (TCBn.CTRLA) register is written to '1', the TCB counter will restart when the TCAn counter restarts.

22.3.4 Events

The TCB can generate the events described in the following table:

Table 22-3. Event Generators in TCB

Generator Name		Description	Event Type	Generating Clock Domain	Length of Event
Peripheral	Event				
TCBn	CAPT	CAPT flag set	Pulse	CLK_PER	One CLK_PER period
	OVF	OVF flag set			

The conditions for generating the CAPT and OVF events are identical to those that will raise the corresponding interrupt flags in the Timer/Counter Interrupt Flags (TCBn.INTFLAGS) register. Refer to the *Event System* section for more details regarding event users and Event System configuration.

The TCB can receive the events described in the following table:

Table 22-4. Event Users and Available Event Actions in TCB

User Name		Description	Input Detection	Async/Sync
Peripheral	Input			
TCBn	CAPT	Time-Out Check Count mode	Edge	Sync
		Input Capture on Event Count mode		
		Input Capture Frequency Measurement Count mode		
		Input Capture Pulse-Width Measurement Count mode		
		Input Capture Frequency and Pulse-Width Measurement Count mode		
		Single-Shot Count mode		
	COUNT	Event as clock source in combination with a count mode		Sync

CAPT and COUNT are TCB event users that detect and act upon input events.

The COUNT event user is enabled on the peripheral by modifying the Clock Select (CLKSEL) bit field in the Control A (TCBn.CTRLA) register to EVENT and setting up the Event System accordingly.

If the Capture Event Input Enable (CAPTEI) bit in the Event Control (TCBn.EVCTRL) register is written to '1', incoming events will result in an event action as defined by the Event Edge (EDGE) bit in Event Control (TCBn.EVCTRL) register and the Timer Mode (CNTMODE) bit field in Control B (TCBn.CTRLB) register. The event needs to last for at least one CLK_PER cycle to be recognized.

If the Asynchronous mode is enabled for Single-Shot mode, the event is edge-triggered and will capture changes on the event input shorter than one peripheral clock cycle.

22.3.5 Interrupts

Table 22-5. Available Interrupt Vectors and Sources

Name	Vector Description	Conditions
CAPT	TCB interrupt	Depending on the operating mode. See the description of the CAPT bit in the TCBn.INTFLAG register.
OVF		The timer/counter overflows from MAX to BOTTOM.

When an interrupt condition occurs, the corresponding interrupt flag is set in the peripheral's Interrupt Flags (*peripheral*.INTFLAGS) register.

An interrupt source is enabled or disabled by writing to the corresponding enable bit in the peripheral's Interrupt Control (*peripheral*.INTCTRL) register.

An interrupt request is generated when the corresponding interrupt source is enabled, and the interrupt flag is set. The interrupt request remains active until the interrupt flag is cleared. See the peripheral's INTFLAGS register for details on how to clear interrupt flags.

22.3.6 Sleep Mode Operation

TCBn is, by default, disabled in Standby sleep mode. It will be halted as soon as the sleep mode is entered.

The module can stay fully operational in the Standby sleep mode if the Run Standby (RUNSTDBY) bit in the TCBn.CTRLA register is written to '1'.

All operations are halted in Power-Down sleep mode.

22.4 Register Summary

Offset	Name	Bit Pos.	7	6	5	4	3	2	1	0
0x00	CTRLA	7:0		RUNSTDBY	CASCADE	SYNCUPD		CLKSEL[2:0]		ENABLE
0x01	CTRLB	7:0		ASYNC	CCMPINIT	CCMPEN		CNTMODE[2:0]		
0x02	Reserved									
0x03										
0x04	EVCTRL	7:0		FILTER		EDGE				CAPTEI
0x05	INTCTRL	7:0							OVF	CAPT
0x06	INTFLAGS	7:0							OVF	CAPT
0x07	STATUS	7:0								RUN
0x08	DBGCTRL	7:0								DBGRUN
0x09	TEMP	7:0	TEMP[7:0]							
0x0A	CNT	7:0	CNT[7:0]							
		15:8	CNT[15:8]							
0x0C	CCMP	7:0	CCMP[7:0]							
		15:8	CCMP[15:8]							

22.5 Register Description

22.5.1 Control A

Name: CTRLA
Offset: 0x00
Reset: 0x00
Property: -

	7	6	5	4	3	2	1	0
		RUNSTDBY	CASCADE	SYNCUPD		CLKSEL[2:0]		ENABLE
Access		R/W	R/W	R/W	R/W	R/W	R/W	R/W
Reset		0	0	0	0	0	0	0

Bit 6 – RUNSTDBY Run Standby

Writing a '1' to this bit will enable the peripheral to run in Standby sleep mode.

Bit 5 – CASCADE Cascade Two Timer/Counters

Writing this bit to '1' enables cascading of two 16-bit Timer/Counters type B (TCBn) for 32-bit operation using the Event System. This bit must be '1' for the timer/counter used for the two Most Significant Bytes (MSB). When this bit is '1', the selected event source for capture (CAPT) is delayed by one peripheral clock cycle. This compensates the carry propagation delay when cascading two counters via the Event System.

Bit 4 – SYNCUPD Synchronize Update

When this bit is written to '1', the TCB will restart whenever TCAn is restarted or overflows. This can be used to synchronize capture with the PWM period. If TCAn is selected as the clock source, the TCB will restart when that TCAn is restarted. For other clock selections, it will restart together with TCA0.

Bits 3:1 – CLKSEL[2:0] Clock Select

Writing these bits selects the clock source for this peripheral.

Value	Name	Description
0x0	DIV1	CLK_PER
0x1	DIV2	CLK_PER / 2
0x2	TCA0	Use CLK_TCA from TCA0
0x3–0x6	-	Reserved
0x7	EVENT	Positive edge on event input

Bit 0 – ENABLE Enable

Writing this bit to '1' enables the Timer/Counter type B peripheral.

22.5.2 Control B

Name: CTRLB
Offset: 0x01
Reset: 0x00
Property: -

	7	6	5	4	3	2	1	0
		ASYNC	CCMPINIT	CCMPEN		CNTMODE[2:0]		
Access		R/W	R/W	R/W		R/W	R/W	R/W
Reset		0	0	0		0	0	0

Bit 6 – ASYNC Asynchronous Enable

Writing this bit to '1' will allow asynchronous updates of the TCB output signal in Single-Shot mode.

Value	Description
0	The output will go HIGH when the counter starts after synchronization
1	The output will go HIGH when an event arrives

Bit 5 – CCMPINIT Compare/Capture Pin Initial Value

This bit is used to set the initial output value of the pin when a pin output is used. This bit has no effect in 8-bit PWM mode and Single-Shot mode.

Value	Description
0	Initial pin state is LOW
1	Initial pin state is HIGH

Bit 4 – CCMPEN Compare/Capture Output Enable

Writing this bit to '1' enables the waveform output. This will make the waveform output available on the corresponding pin, overriding the value in the corresponding PORT output register. The corresponding pin direction must be configured as an output in the PORT peripheral.

Value	Description
0	Waveform output is not enabled on the corresponding pin
1	Waveform output will override the output value of the corresponding pin

Bits 2:0 – CNTMODE[2:0] Timer Mode

Writing to this bit field selects the Timer mode.

Value	Name	Description
0x0	INT	Periodic Interrupt mode
0x1	TIMEOUT	Time-out Check mode
0x2	CAPT	Input Capture on Event mode
0x3	FRQ	Input Capture Frequency Measurement mode
0x4	PW	Input Capture Pulse-Width Measurement mode
0x5	FRQPW	Input Capture Frequency and Pulse-Width Measurement mode
0x6	SINGLE	Single-Shot mode
0x7	PWM8	8-Bit PWM mode

22.5.3 Event Control

Name: EVCTRL
Offset: 0x04
Reset: 0x00
Property: -

	7	6	5	4	3	2	1	0
Access		FILTER		EDGE				CAPTEI
Reset		R/W		R/W				R/W
		0		0				0

Bit 6 – FILTER Input Capture Noise Cancellation Filter
 Writing this bit to '1' enables the Input Capture Noise Cancellation unit.

Bit 4 – EDGE Event Edge
 This bit is used to select the event edge. The effect of this bit is dependent on the selected Count Mode (CNTMODE) bit field in TCBn.CTRLB. “—” means that an event or edge has no effect in this mode.

Count Mode	EDGE	Positive Edge	Negative Edge
Periodic Interrupt mode	0	—	—
	1	—	—
Timeout Check mode	0	Start counter	Stop counter
	1	Stop counter	Start counter
Input Capture on Event mode	0	Input Capture, interrupt	—
	1	—	Input Capture, interrupt
Input Capture Frequency Measurement mode	0	Input Capture, clear and restart counter, interrupt	—
	1	—	Input Capture, clear and restart counter, interrupt
Input Capture Pulse-Width Measurement mode	0	Clear and restart counter	Input Capture, interrupt
	1	Input Capture, interrupt	Clear and restart counter
Input Capture Frequency and Pulse Width Measurement mode	0	<ul style="list-style-type: none"> On the 1st Positive: Clear and restart counter On the following Negative: Input Capture On the 2nd Positive: Stop counter, interrupt 	
	1	<ul style="list-style-type: none"> On the 1st Negative: Clear and restart counter On the following Positive: Input Capture On the 2nd Negative: Stop counter, interrupt 	
Single-Shot mode	0	Start counter	—
	1	Start counter	Start counter
8-Bit PWM mode	0	—	—
	1	—	—

Bit 0 – CAPTEI Capture Event Input Enable
 Writing this bit to '1' enables the input capture event.

22.5.4 Interrupt Control

Name: INTCTRL
Offset: 0x05
Reset: 0x00
Property: -

Bit	7	6	5	4	3	2	1	0
Access							OVF	CAPT
Reset							R/W	R/W
							0	0

Bit 1 – OVF Overflow Interrupt Enable
Writing this bit to '1' enables interrupt on overflow.

Bit 0 – CAPT Capture Interrupt Enable
Writing this bit to '1' enables interrupt on capture.

22.5.5 Interrupt Flags

Name: INTFLAGS
Offset: 0x06
Reset: 0x00
Property: -

	7	6	5	4	3	2	1	0
							OVF	CAPT
Access							R/W	R/W
Reset							0	0

Bit 1 – OVF Overflow Interrupt Flag

This bit is set when an overflow interrupt occurs. The flag is set whenever the timer/counter wraps from MAX to BOTTOM.

The bit is cleared by writing a ‘1’ to the bit position.

Bit 0 – CAPT Capture Interrupt Flag

This bit is set when a capture interrupt occurs. The interrupt conditions are dependent on the Counter Mode (CNTMODE) bit field in the Control B (TCBn.CTRLB) register.

This bit is cleared by writing a ‘1’ to it or when the Capture register is read in Capture mode.

Table 22-6. Interrupt Sources Set Conditions by Counter Mode

Counter Mode	Interrupt Set Condition	TOP Value	CAPT
Periodic Interrupt mode	Set when the counter reaches TOP	CCMP	CNT == TOP
Timeout Check mode	Set when the counter reaches TOP		
Single-Shot mode	Set when the counter reaches TOP		
Input Capture Frequency Measurement mode	Set on edge when the Capture register is loaded and the counter restarts; the flag clears when the capture is read	--	On Event, copy CNT to CCMP, and restart counting (CNT == BOTTOM)
Input Capture on Event mode	Set when an event occurs and the Capture register is loaded; the flag clears when the capture is read		
Input Capture Pulse-Width Measurement mode	Set on edge when the Capture register is loaded; the previous edge initialized the count; the flag clears when the capture is read		
Input Capture Frequency and Pulse-Width Measurement mode	Set on the second edge (positive or negative) when the counter is stopped; the flag clears when the capture is read		
8-Bit PWM mode	Set when the counter reaches CCMH	CCML	CNT == CCMH

22.5.6 Status

Name: STATUS
Offset: 0x07
Reset: 0x00
Property: -

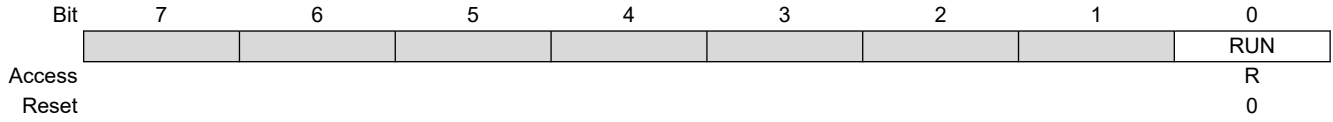

Bit 0 – RUN Run

When the counter is running, this bit is set to '1'. When the counter is stopped, this bit is cleared to '0'.
 The bit is read-only and cannot be set by UPDI.

22.5.7 Debug Control

Name: DBGCTRL
Offset: 0x08
Reset: 0x00
Property: -

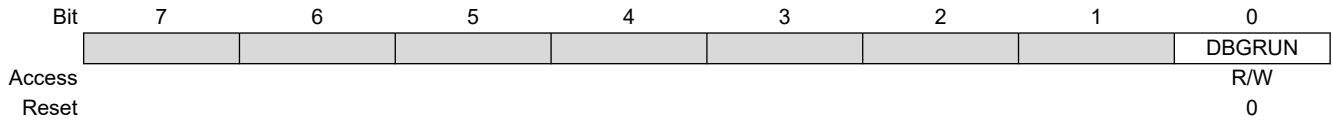

Bit 0 – DBGRUN Debug Run

Value	Description
0	The peripheral is halted in Break Debug mode and ignores events
1	The peripheral will continue to run in Break Debug mode when the CPU is halted

22.5.8 Temporary Value

Name: TEMP
Offset: 0x09
Reset: 0x00
Property: -

The Temporary register is used by the CPU for 16-bit single-cycle access to the 16-bit registers of this peripheral. The register is common for all the 16-bit registers of this peripheral and can be read and written by software. For more details on reading and writing 16-bit registers, refer to *Accessing 16-Bit Registers* in the *AVR CPU* section.

Bit	7	6	5	4	3	2	1	0
	TEMP[7:0]							
Access	R/W	R/W	R/W	R/W	R/W	R/W	R/W	R/W
Reset	0	0	0	0	0	0	0	0

Bits 7:0 – TEMP[7:0] Temporary Value

22.5.9 Count

Name: CNT
Offset: 0x0A
Reset: 0x00
Property: -

The TCBn.CNTL and TCBn.CNTH register pair represents the 16-bit value TCBn.CNT. The low byte [7:0] (suffix L) is accessible at the original offset. The high byte [15:8] (suffix H) can be accessed at offset + 0x01.

CPU and UPDI write access has priority over internal updates of the register.

	Bit	15	14	13	12	11	10	9	8
		CNT[15:8]							
Access		R/W	R/W	R/W	R/W	R/W	R/W	R/W	R/W
Reset		0	0	0	0	0	0	0	0
	Bit	7	6	5	4	3	2	1	0
		CNT[7:0]							
Access		R/W	R/W	R/W	R/W	R/W	R/W	R/W	R/W
Reset		0	0	0	0	0	0	0	0

Bits 15:8 – CNT[15:8] Count Value High
 These bits hold the MSB of the 16-bit Counter register.

Bits 7:0 – CNT[7:0] Count Value Low
 These bits hold the LSB of the 16-bit Counter register.

22.5.10 Capture/Compare

Name: CCMP
Offset: 0x0C
Reset: 0x00
Property: -

The TCBn.CCMPL and TCBn.CCMPH register pair represents the 16-bit value TCBn.CCMP. The low byte [7:0] (suffix L) is accessible at the original offset. The high byte [15:8] (suffix H) can be accessed at offset + 0x01.

This register has different functions depending on the mode of operation:

- For Capture operation, these registers contain the captured value of the counter at the time the capture occurs
- In Periodic Interrupt/Time-Out and Single-Shot mode, this register acts as the TOP value
- In 8-bit PWM mode, TCBn.CCMPL and TCBn.CCMPH act as two independent registers: The period of the waveform is controlled by CCMPH, while CCMPH controls the duty cycle.

Bit	15	14	13	12	11	10	9	8
	CCMP[15:8]							
Access	R/W	R/W	R/W	R/W	R/W	R/W	R/W	R/W
Reset	0	0	0	0	0	0	0	0
Bit	7	6	5	4	3	2	1	0
	CCMP[7:0]							
Access	R/W	R/W	R/W	R/W	R/W	R/W	R/W	R/W
Reset	0	0	0	0	0	0	0	0

Bits 15:8 – CCMP[15:8] Capture/Compare Value High Byte

These bits hold the MSB of the 16-bit compare, capture, and top value.

Bits 7:0 – CCMP[7:0] Capture/Compare Value Low Byte

These bits hold the LSB of the 16-bit compare, capture, and top value.

23. RTC - Real-Time Counter

23.1 Features

- 16-Bit Resolution
- Selectable Clock Sources
- Programmable 15-Bit Clock Prescaling
- One Compare Register
- One Period Register
- Clear Timer on Period Overflow
- Optional Interrupt/Event on Overflow and Compare Match
- Periodic Interrupt and Event
- Crystal Error Correction

23.2 Overview

The RTC peripheral offers two timing functions: The Real-Time Counter (RTC) and a Periodic Interrupt Timer (PIT).

The PIT functionality can be enabled independently of the RTC functionality.

RTC - Real-Time Counter

The RTC counts (prescaled) clock cycles in a Counter register and compares the content of the Counter register to a Period register and a Compare register.

The RTC can generate both interrupts and events on compare match or overflow. It will generate a compare interrupt and/or event at the first count after the counter value equals the Compare register value, and an overflow interrupt and/or event at the first count after the counter value equals the Period register value. The overflow will reset the counter value to zero.

The RTC peripheral typically runs continuously, including in Low-Power sleep modes, to keep track of time. It can wake up the device from sleep modes, and/or interrupt the device at regular intervals.

The reference clock is typically the 32.768 kHz output from an external crystal. The RTC can also be clocked from an external clock signal, the 32.768 kHz internal ultra-low power oscillator (OSCULP32K), or the OSCULP32K divided by 32.

The RTC peripheral includes a 15-bit programmable prescaler that can scale down the reference clock before it reaches the counter. A wide range of resolutions and time-out periods can be configured for the RTC. With a 32.768 kHz clock source, the maximum resolution is 30.5 μ s, and time-out periods can be up to two seconds. With a resolution of 1s, the maximum time-out period is more than 18 hours (65536 seconds).

The RTC also supports crystal error correction when operated using external crystal selection. An externally calibrated value will be used for correction. The software can adjust the RTC with an accuracy of ± 1 PPM, and the maximum adjustment is ± 127 PPM. The RTC correction operation will either speed up (by skipping count) or slow down (by adding extra count) the prescaler to account for the crystal error.

PIT - Periodic Interrupt Timer

The PIT uses the same clock source (CLK_RTC) as the RTC function and can generate an interrupt request or a level event on every n^{th} clock period. The n can be selected from {4, 8, 16,... 32768} for interrupts, and from {64, 128, 256,... 8192} for events.

23.2.1 RTC Block Diagram

Figure 23-1. Block Diagram

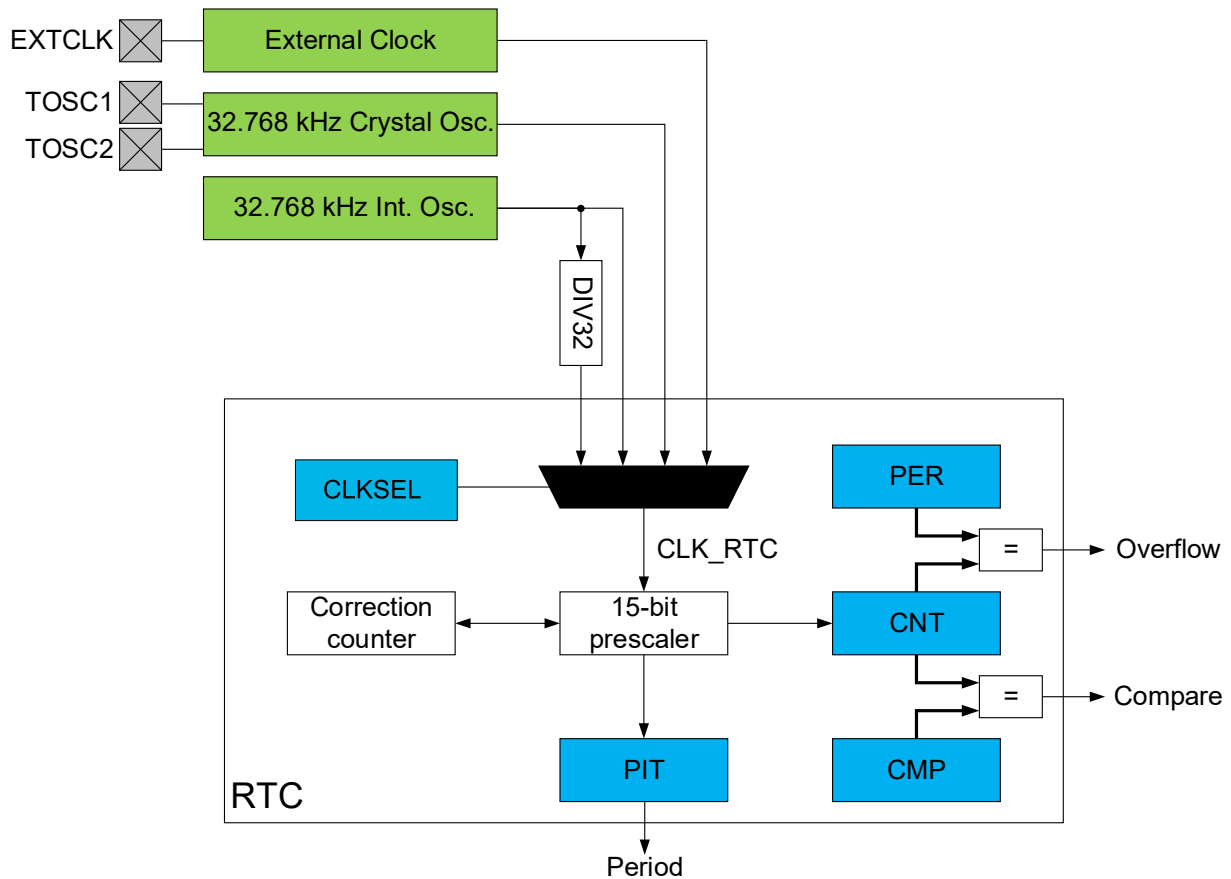

23.3 Clocks

The peripheral clock (CLK_PER) is required to be at least four times faster than the RTC clock (CLK_RTC) for reading the counter value, regardless of the prescaler setting.

A 32.768 kHz crystal can be connected to the TOSC1 or TOSC2 pins, along with any required load capacitors. Alternatively, an external digital clock can be connected to the TOSC1 pin.

23.4 RTC Functional Description

The RTC peripheral offers two timing functions: The Real-Time Counter (RTC) and a Periodic Interrupt Timer (PIT). This subsection describes the RTC.

23.4.1 Initialization

Before enabling the RTC peripheral and the desired actions (interrupt requests and output events), the source clock for the RTC counter must be configured to operate the RTC.

23.4.1.1 Configure the Clock CLK_RTC

To configure the CLK_RTC, follow these steps:

1. Configure the desired oscillator to operate as required, in the Clock Controller (CLKCTRL) peripheral.
2. Write the Clock Select (CLKSEL) bit field in the Clock Selection (RTC.CLKSEL) register accordingly.

The CLK_RTC clock configuration is used by both RTC and PIT functionalities.

23.4.1.2 Configure RTC

To operate the RTC, follow these steps:

1. Set the compare value in the Compare (RTC.CMP) register, and/or the overflow value in the Period (RTC.PER) register.
2. Enable the desired interrupts by writing to the respective interrupt enable bits (CMP, OVF) in the Interrupt Control (RTC.INTCTRL) register.
3. Configure the RTC internal prescaler by writing the desired value to the Prescaler (PRESCALER) bit field in the Control A (RTC.CTRLA) register.
4. Enable the RTC by writing a '1' to the RTC Peripheral Enable (RTCEN) bit in the RTC.CTRLA register.

23.4.2 Operation - RTC

23.4.2.1 Enabling and Disabling

The RTC is enabled by writing the RTC Peripheral Enable (RTCEN) bit in the Control A (RTC.CTRLA) register to '1'. The RTC is disabled by writing the RTC Peripheral Enable (RTCEN) bit in RTC.CTRLA to '0'.

23.5 PIT Functional Description

The RTC peripheral offers two timing functions: The Real-Time Counter (RTC) and a Periodic Interrupt Timer (PIT). This subsection describes the PIT.

23.5.1 Initialization

To operate the PIT, follow these steps:

1. Configure the RTC clock CLK_RTC as described in section [23.4.1.1. Configure the Clock CLK_RTC](#).
2. Enable the interrupt by writing a '1' to the Periodic Interrupt (PI) bit in the PIT Interrupt Control (RTC.PITINTCTRL) register.
3. Select the period for the interrupt by writing the desired value to the Period (PERIOD) bit field in the Periodic Interrupt Timer Control A (RTC.PITCTRLA) register.
4. Enable the PIT by writing a '1' to the Periodic Interrupt Timer Enable (PITEN) bit in the RTC.PITCTRLA register.

23.5.2 Operation - PIT

23.5.2.1 Enabling and Disabling

The PIT is enabled by writing the Periodic Interrupt Timer Enable (PITEN) bit in the Periodic Interrupt Timer Control A (RTC.PITCTRLA) register to '1'. The PIT is disabled by writing the Periodic Interrupt Timer Enable (PITEN) bit in RTC.PITCTRLA to '0'.

23.5.2.2 PIT Interrupt Timing

Timing of the First Interrupt

Both PIT and RTC functions are running from the same counter inside the prescaler and can be configured as described below:

- The RTC interrupt period is configured by writing the Period (RTC.PER) register
- The PIT interrupt period is configured by writing the Period (PERIOD) bit field in Periodic Interrupt Timer Control A (RTC.PITCTRLA) register

The prescaler is OFF when both functions are OFF (RTC Peripheral Enable (RTCEN) bit in RTC.CTRLA and the Periodic Interrupt Timer Enable (PITEN) bit in RTC.PITCTRLA are '0'), but it is running (that is, its internal counter is counting) when either function is enabled. For this reason, the timing of the first PIT interrupt and the first RTC count tick will be unknown (anytime between enabling and a full period).

Continuous Operation

After the first interrupt, the PIT will continue toggling every $\frac{1}{2}$ PIT period resulting in a full PIT period signal.

Example 23-1. PIT Timing Diagram for PERIOD = CYC16

For PERIOD = CYC16 in RTC.PITCTRLA, the PIT output effectively follows the state of the prescaler counter bit 3, so the resulting interrupt output has a period of 16 CLK_RTC cycles.

The time between writing PITEN to '1' and the first PIT interrupt can vary between virtually zero and a full PIT period of 16 CLK_RTC cycles. The precise delay between enabling the PIT and its first output depends on the prescaler's counting phase: The first interrupt shown below is produced by writing PITEN to '1' at any time inside the leading time window.

Figure 23-2. Timing Between PIT Enable and First Interrupt

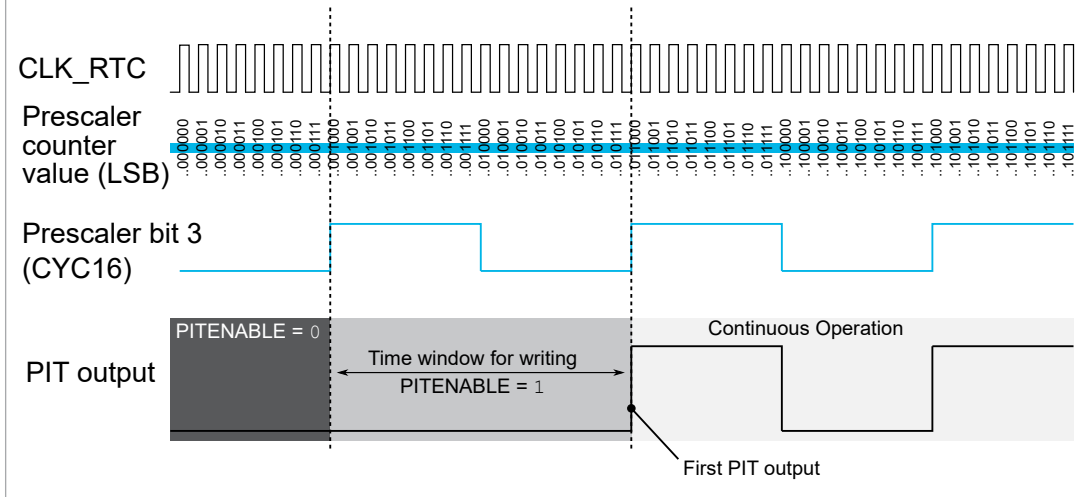

23.6 Crystal Error Correction

The prescaler for the RTC and PIT can do internal frequency correction of the crystal clock by using the PPM error value from the Crystal Frequency Calibration (CALIB) register when the Frequency Correction Enable (CORREN) bit in the RTC.CTRLA register is '1'.

The CALIB register must be written by the user, based on the information about the frequency error. Perform the correction operation by adding or removing some cycles equal to the value given in the Error Correction Value (ERROR) bit field in the CALIB register spread throughout a million-cycle interval.

The RTC count value available through the Count (RTC.CNT) registers or in the PIT intervals will reflect the clock correction.

If disabling the correction feature, an ongoing correction cycle will be completed before the function is disabled.

Note: If using this feature with a negative correction, the minimum prescaler configuration is DIV2.

23.7 Events

The RTC can generate the events described in the following table:

Generator Name		Description	Event Type	Generating Clock Domain	Length of Event
Peripheral	Event				
RTC	OVF	Overflow	Pulse	CLK_RTC	One CLK_RTC period
	CMP	Compare Match			
	PIT_DIV8192	Prescaled RTC clock divided by 8192	Level		Given by prescaled RTC clock divided by 8192
	PIT_DIV4096	Prescaled RTC clock divided by 4096			Given by prescaled RTC clock divided by 4096
	PIT_DIV2048	Prescaled RTC clock divided by 2048			Given by prescaled RTC clock divided by 2048
	PIT_DIV1024	Prescaled RTC clock divided by 1024			Given by prescaled RTC clock divided by 1024
	PIT_DIV512	Prescaled RTC clock divided by 512			Given by prescaled RTC clock divided by 512
	PIT_DIV256	Prescaled RTC clock divided by 256			Given by prescaled RTC clock divided by 256
	PIT_DIV128	Prescaled RTC clock divided by 128			Given by prescaled RTC clock divided by 128
	PIT_DIV64	Prescaled RTC clock divided by 64			Given by prescaled RTC clock divided by 64

The conditions for generating the OVF and CMP events are identical to those that will raise the corresponding interrupt flags in the RTC.INTFLAGS register.

Refer to the *EVSYS - Event System* section for more details regarding event users and Event System configuration.

23.8 Interrupts

Table 23-1. Available Interrupt Vectors and Sources

Name	Vector Description	Conditions
RTC	Real-Time Counter overflow and compare match interrupt	<ul style="list-style-type: none"> Overflow (OVF): The counter has reached the value from the RTC.PER register and wrapped to zero Compare (CMP): Match between the value from the Counter (RTC.CNT) register and the value from the Compare (RTC.CMP) register
PIT	Periodic Interrupt Timer interrupt	A time period has passed, as configured by the PERIOD bit field in RTC.PITCTRLA

When an interrupt condition occurs, the corresponding interrupt flag is set in the peripheral's Interrupt Flags (*peripheral*.INTFLAGS) register.

An interrupt source is enabled or disabled by writing to the corresponding enable bit in the peripheral's Interrupt Control (*peripheral*.INTCTRL) register.

An interrupt request is generated when the corresponding interrupt source is enabled, and the interrupt flag is set. The interrupt request remains active until the interrupt flag is cleared. See the peripheral's INTFLAGS register for details on how to clear interrupt flags.

Note that:

- The RTC has two INTFLAGS registers: RTC.INTFLAGS and RTC.PITINTFLAGS.
- The RTC has two INTCTRL registers: RTC.INTCTRL and RTC.PITINTCTRL.

23.9 Sleep Mode Operation

The RTC will continue to operate in Idle sleep mode. It will run in Standby sleep mode if the Run in Standby (RUNSTDBY) bit in RTC.CTRLA is set.

The PIT will continue to operate in any sleep mode.

23.10 Synchronization

Both the RTC and the PIT are asynchronous, operating from a different clock source (CLK_RTC) independently of the peripheral clock (CLK_PER). For Control and Count register updates, it will take some RTC and/or peripheral clock cycles before an updated register value is available in a register or until a configuration change affects the RTC or PIT, respectively. This synchronization time is described for each register in the *Register Description* section.

For some RTC registers, a Synchronization Busy (CMPBUSY, PERBUSY, CNTBUSY, CTRLABUSY) flag is available in the Status (RTC.STATUS) register.

For the RTC.PITCTRLA register, a Synchronization Busy (CTRLBUSY) flag is available in the Periodic Interrupt Timer Status (RTC.PITSTATUS) register.

Check these flags before writing to the mentioned registers.

23.11 Debug Operation

If the Debug Run (DBGRUN) bit in the Debug Control (RTC.DBGCTRL) register is '1', the RTC will continue normal operation. If DBGRUN is '0' and the CPU is halted, the RTC will halt the operation and ignore any incoming events.

If the Debug Run (DBGRUN) bit in the Periodic Interrupt Timer Debug Control (RTC.PITDBGCTRL) register is '1', the PIT will continue normal operation. If DBGRUN is '0' in the Debug mode and the CPU is halted, the PIT output will be low. When the PIT output is high at the time, a new positive edge occurs to set the interrupt flag when restarting from a break. The result is an additional PIT interrupt that does not happen during normal operation. If the PIT output is low at the break, the PIT will resume low without additional interrupt.

23.12 Register Summary

Offset	Name	Bit Pos.	7	6	5	4	3	2	1	0
0x00	CTRLA	7:0	RUNSTDBY	PRESCALER[3:0]				CORREN		RTCEN
0x01	STATUS	7:0					CMPBUSY	PERBUSY	CNTBUSY	CTRLABUSY
0x02	INTCTRL	7:0							CMP	OVF
0x03	INTFLAGS	7:0							CMP	OVF
0x04	TEMP	7:0	TEMP[7:0]							
0x05	DBGCTRL	7:0								DBGRUN
0x06	CALIB	7:0	SIGN	ERROR[6:0]						
0x07	CLKSEL	7:0							CLKSEL[1:0]	
0x08	CNT	7:0	CNT[7:0]							
		15:8	CNT[15:8]							
0x0A	PER	7:0	PER[7:0]							
		15:8	PER[15:8]							
0x0C	CMP	7:0	CMP[7:0]							
		15:8	CMP[15:8]							
0x0E ... 0x0F	Reserved									
0x10	PITCTRLA	7:0		PERIOD[3:0]						PITEN
0x11	PITSTATUS	7:0								CTRLBUSY
0x12	PITINTCTRL	7:0								PI
0x13	PITINTFLAGS	7:0								PI
0x14	Reserved									
0x15	PITDBGCTRL	7:0								DBGRUN

23.13 Register Description

23.13.1 Control A

Name: CTRLA
Offset: 0x00
Reset: 0x00
Property: -

Bit	7	6	5	4	3	2	1	0
	RUNSTDBY	PRESCALER[3:0]			CORREN			RTCEN
Access	R/W	R/W	R/W	R/W	R/W	R/W		R/W
Reset	0	0	0	0	0	0		0

Bit 7 – RUNSTDBY Run in Standby

Value	Description
0	RTC disabled in Standby sleep mode
1	RTC enabled in Standby sleep mode

Bits 6:3 – PRESCALER[3:0] Prescaler

These bits define the prescaling of the CLK_RTC clock signal. Due to synchronization between the RTC clock and the peripheral clock, there is a latency of two RTC clock cycles from updating the register until this has an effect. Application software needs to check that the CTRLABUSY flag in the RTC.STATUS register is cleared before writing to this register.

Value	Name	Description
0x0	DIV1	RTC clock/1 (no prescaling)
0x1	DIV2	RTC clock/2
0x2	DIV4	RTC clock/4
0x3	DIV8	RTC clock/8
0x4	DIV16	RTC clock/16
0x5	DIV32	RTC clock/32
0x6	DIV64	RTC clock/64
0x7	DIV128	RTC clock/128
0x8	DIV256	RTC clock/256
0x9	DIV512	RTC clock/512
0xA	DIV1024	RTC clock/1024
0xB	DIV2048	RTC clock/2048
0xC	DIV4096	RTC clock/4096
0xD	DIV8192	RTC clock/8192
0xE	DIV16384	RTC clock/16384
0xF	DIV32768	RTC clock/32768

Bit 2 – CORREN Frequency Correction Enable

Value	Description
0	Frequency correction is disabled
1	Frequency correction is enabled

Bit 0 – RTCEN RTC Peripheral Enable

Value	Description
0	RTC peripheral is disabled
1	RTC peripheral is enabled

23.13.2 Status

Name: STATUS
Offset: 0x01
Reset: 0x00
Property: -

Bit	7	6	5	4	3	2	1	0
					CMPBUSY	PERBUSY	CNTBUSY	CTRLABUSY
Access					R	R	R	R
Reset					0	0	0	0

Bit 3 – CMPBUSY Compare Synchronization Busy

This bit is '1' when the RTC is busy synchronizing the Compare (RTC.CMP) register in the RTC clock domain.

Bit 2 – PERBUSY Period Synchronization Busy

This bit is '1' when the RTC is busy synchronizing the Period (RTC.PER) register in the RTC clock domain.

Bit 1 – CNTBUSY Counter Synchronization Busy

This bit is '1' when the RTC is busy synchronizing the Count (RTC.CNT) register in the RTC clock domain.

Bit 0 – CTRLABUSY Control A Synchronization Busy

This bit is '1' when the RTC is busy synchronizing the Control A (RTC.CTRLA) register in the RTC clock domain.

23.13.3 Interrupt Control

Name: INTCTRL
Offset: 0x02
Reset: 0x00
Property: -

Bit	7	6	5	4	3	2	1	0
Access							CMP	OVF
Reset							R/W	R/W
							0	0

Bit 1 – CMP Compare Match Interrupt Enable

Enable interrupt-on-compare match (that is, when the value from the Count (RTC.CNT) register matches the value from the Compare (RTC.CMP) register).

Value	Description
0	The compare match interrupt is disabled
1	The compare match interrupt is enabled

Bit 0 – OVF Overflow Interrupt Enable

Enable interrupt-on-counter overflow (that is, when the value from the Count (RTC.CNT) register matched the value from the Period (RTC.PER) register and wraps around to zero).

Value	Description
0	The overflow interrupt is disabled
1	The overflow interrupt is enabled

23.13.4 Interrupt Flag

Name: INTFLAGS
Offset: 0x03
Reset: 0x00
Property: -

Bit	7	6	5	4	3	2	1	0
							CMP	OVF
Access							R/W	R/W
Reset							0	0

Bit 1 – CMP Compare Match Interrupt Flag

This flag is set when the value from the Count (RTC.CNT) register matches the value from the Compare (RTC.CMP) register.

Writing a '1' to this bit clears the flag.

Bit 0 – OVF Overflow Interrupt Flag

This flag is set when the value from the Count (RTC.CNT) register has reached the value from the Period (RTC.PER) register and wrapped to zero.

Writing a '1' to this bit clears the flag.

23.13.5 Temporary

Name: TEMP
Offset: 0x4
Reset: 0x00
Property: -

The Temporary register is used by the CPU for 16-bit single-cycle access to the 16-bit registers of this peripheral. The register is common for all the 16-bit registers of this peripheral and can be read and written by software. For more details on reading and writing 16-bit registers, refer to *Accessing 16-Bit Registers* in the *AVR CPU* section.

Bit	7	6	5	4	3	2	1	0
	TEMP[7:0]							
Access	R/W	R/W	R/W	R/W	R/W	R/W	R/W	R/W
Reset	0	0	0	0	0	0	0	0

Bits 7:0 – TEMP[7:0] Temporary

Temporary register for read/write operations in 16-bit registers.

23.13.6 Debug Control

Name: DBGCTRL
Offset: 0x05
Reset: 0x00
Property: -

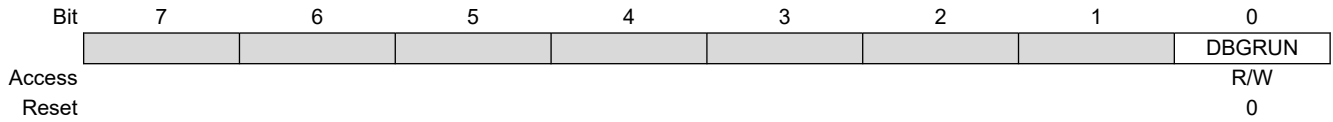

Bit 0 – DBGRUN Debug Run

Value	Description
0	The peripheral is halted in Break Debug mode and ignores events
1	The peripheral will continue to run in Break Debug mode when the CPU is halted

23.13.7 Crystal Frequency Calibration

Name: CALIB
Offset: 0x06
Reset: 0x00
Property: -

This register stores the error value and the type of correction to be done. The register is written by software with an error value based on external calibration and/or temperature correction/s.

Bit	7	6	5	4	3	2	1	0
	SIGN	ERROR[6:0]						
Access	R/W	R/W	R/W	R/W	R/W	R/W	R/W	R/W
Reset	0	0	0	0	0	0	0	0

Bit 7 – SIGN Error Correction Sign Bit

This bit shows the direction of the correction.

Value	Description
0x0	Positive correction causing the prescaler to count slower
0x1	Negative correction causing the prescaler to count faster. This requires that the minimum prescaler configuration is DIV2

Bits 6:0 – ERROR[6:0] Error Correction Value

The number of correction clocks for each million RTC clock cycles interval (PPM).

23.13.8 Clock Selection

Name: CLKSEL
Offset: 0x07
Reset: 0x00
Property: -

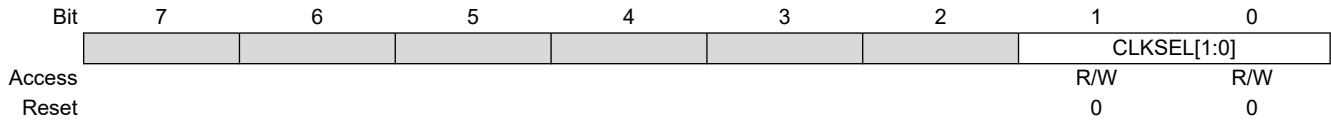

Bits 1:0 – CLKSEL[1:0] Clock Select

Writing these bits select the source for the RTC clock (CLK_RTC).

When configuring the RTC to use either XOSC32K or the external clock on TOSC1, XOSC32K needs to be enabled, and the Source Select (SEL) bit and Run Standby (RUNSTDBY) bit in the XOSC32K Control A of the Clock Controller (CLKCTRL.XOSC32KCTRLA) register must be configured accordingly.

Value	Name	Description
0x00	INT32K	Internal 32.768 kHz oscillator
0x01	INT1K	Internal 1.024 kHz oscillator
0x02	TOSC32K	32.768 kHz crystal oscillator
0x03	EXTCLK	External clock from EXTCLK pin

23.13.9 Count

Name: CNT
Offset: 0x08
Reset: 0x0000
Property: -

The RTC.CNTL and RTC.CNTH register pair represents the 16-bit value, RTC.CNT. The low byte [7:0] (suffix L) is accessible at the original offset. The high byte [15:8] (suffix H) can be accessed at offset + 0x01.

Due to the synchronization between the RTC clock and main clock domains, there is a latency of two RTC clock cycles from updating the register until this has an effect. The application software needs to check that the CNTBUSY flag in RTC.STATUS is cleared before writing to this register.

Bit	15	14	13	12	11	10	9	8
	CNT[15:8]							
Access	R/W	R/W	R/W	R/W	R/W	R/W	R/W	R/W
Reset	0	0	0	0	0	0	0	0
Bit	7	6	5	4	3	2	1	0
	CNT[7:0]							
Access	R/W	R/W	R/W	R/W	R/W	R/W	R/W	R/W
Reset	0	0	0	0	0	0	0	0

Bits 15:8 – CNT[15:8] Counter High Byte

These bits hold the MSB of the 16-bit Counter register.

Bits 7:0 – CNT[7:0] Counter Low Byte

These bits hold the LSB of the 16-bit Counter register.

23.13.10 Period

Name: PER
Offset: 0x0A
Reset: 0xFFFF
Property: -

The RTC.PERL and RTC.PERH register pair represents the 16-bit value, RTC.PER. The low byte [7:0] (suffix L) is accessible at the original offset. The high byte [15:8] (suffix H) can be accessed at offset + 0x01.

Due to the synchronization between the RTC clock and main clock domains, there is a latency of two RTC clock cycles from updating the register until this has an effect. The application software needs to check that the PERBUSY flag in RTC.STATUS is cleared before writing to this register.

Bit	15	14	13	12	11	10	9	8
	PER[15:8]							
Access	R/W	R/W	R/W	R/W	R/W	R/W	R/W	R/W
Reset	1	1	1	1	1	1	1	1
Bit	7	6	5	4	3	2	1	0
	PER[7:0]							
Access	R/W	R/W	R/W	R/W	R/W	R/W	R/W	R/W
Reset	1	1	1	1	1	1	1	1

Bits 15:8 – PER[15:8] Period High Byte

These bits hold the MSB of the 16-bit Period register.

Bits 7:0 – PER[7:0] Period Low Byte

These bits hold the LSB of the 16-bit Period register.

23.13.11 Compare

Name: CMP
Offset: 0x0C
Reset: 0x0000
Property: -

The RTC.CMPL and RTC.CMPH register pair represents the 16-bit value, RTC.CMP. The low byte [7:0] (suffix L) is accessible at the original offset. The high byte [15:8] (suffix H) can be accessed at offset + 0x01.

Bit	15	14	13	12	11	10	9	8
	CMP[15:8]							
Access	R/W	R/W	R/W	R/W	R/W	R/W	R/W	R/W
Reset	0	0	0	0	0	0	0	0
Bit	7	6	5	4	3	2	1	0
	CMP[7:0]							
Access	R/W	R/W	R/W	R/W	R/W	R/W	R/W	R/W
Reset	0	0	0	0	0	0	0	0

Bits 15:8 – CMP[15:8] Compare High Byte
 These bits hold the MSB of the 16-bit Compare register.

Bits 7:0 – CMP[7:0] Compare Low Byte
 These bits hold the LSB of the 16-bit Compare register.

23.13.12 Periodic Interrupt Timer Control A

Name: PITCTRLA
Offset: 0x10
Reset: 0x00
Property: -

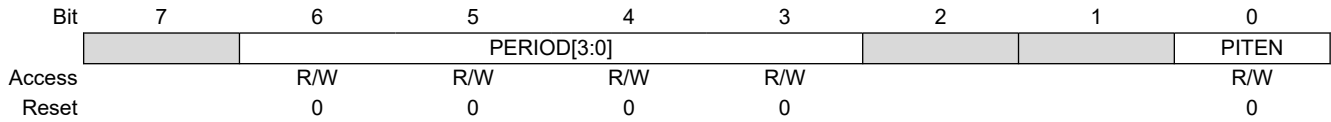

Bits 6:3 – PERIOD[3:0] Period

Writing this bit field selects the number of RTC clock cycles between each interrupt.

Value	Name	Description
0x0	OFF	No interrupt
0x1	CYC4	4 cycles
0x2	CYC8	8 cycles
0x3	CYC16	16 cycles
0x4	CYC32	32 cycles
0x5	CYC64	64 cycles
0x6	CYC128	128 cycles
0x7	CYC256	256 cycles
0x8	CYC512	512 cycles
0x9	CYC1024	1024 cycles
0xA	CYC2048	2048 cycles
0xB	CYC4096	4096 cycles
0xC	CYC8192	8192 cycles
0xD	CYC16384	16384 cycles
0xE	CYC32768	32768 cycles
0xF	-	Reserved

Bit 0 – PITEN Periodic Interrupt Timer Enable

Value	Description
0	Periodic Interrupt Timer disabled
1	Periodic Interrupt Timer enabled

23.13.13 Periodic Interrupt Timer Status

Name: PITSTATUS
Offset: 0x11
Reset: 0x00
Property: -

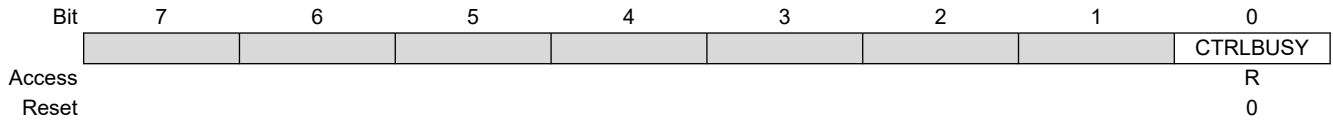

Bit 0 – CTRLBUSY PITCTRLA Synchronization Busy

This bit is '1' when the RTC is busy synchronizing the Periodic Interrupt Timer Control A (RTC.PITCTRLA) register in the RTC clock domain.

23.13.14 PIT Interrupt Control

Name: PITINTCTRL
Offset: 0x12
Reset: 0x00
Property: -

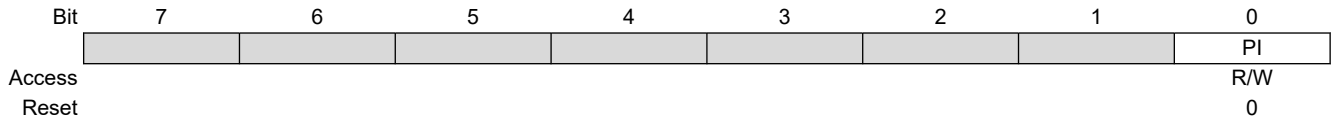

Bit 0 – PI Periodic Interrupt

Value	Description
0	The periodic interrupt is disabled
1	The periodic interrupt is enabled

23.13.15 PIT Interrupt Flag

Name: PITINTFLAGS
Offset: 0x13
Reset: 0x00
Property: -

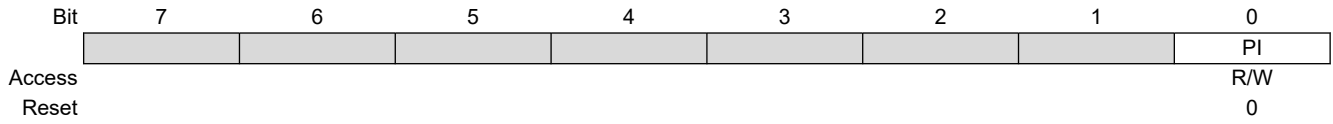

Bit 0 – PI Periodic Interrupt Flag
This flag is set when a periodic interrupt is issued.
Writing a '1' clears the flag.

23.13.16 Periodic Interrupt Timer Debug Control

Name: PITDBGCTRL
Offset: 0x15
Reset: 0x00
Property: -

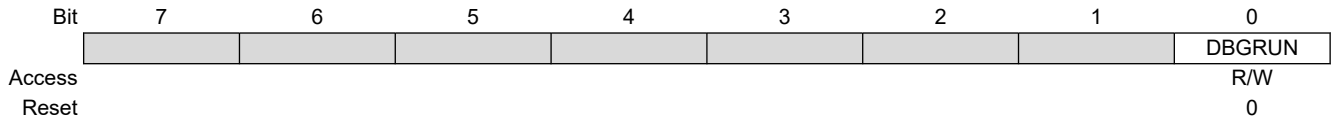

Bit 0 – DBGRUN Debug Run

Value	Description
0	The peripheral is halted in Break Debug mode and ignores events
1	The peripheral will continue to run in Break Debug mode when the CPU is halted

24. USART - Universal Synchronous and Asynchronous Receiver and Transmitter

24.1 Features

- Full-Duplex Operation
- Half-Duplex Operation:
 - One-Wire mode
 - RS-485 mode
- Asynchronous or Synchronous Operation
- Supports Serial Frames with Five, Six, Seven, Eight or Nine Data Bits and One or Two Stop Bits
- Fractional Baud Rate Generator:
 - Can generate the desired baud rate from any peripheral clock frequency
 - No need for an external oscillator
- Built-In Error Detection and Correction Schemes:
 - Odd or even parity generation and parity check
 - Buffer overflow and frame error detection
 - Noise filtering including false Start bit detection and digital low-pass filter
- Separate Interrupts for:
 - Transmit complete
 - Transmit Data register empty
 - Receive complete
- Host SPI Mode
- Multiprocessor Communication Mode
- Start-of-Frame Detection
- I²C Module for IrDA[®] Compliant Pulse Modulation/Demodulation
- LIN Client Support

24.2 Overview

The Universal Synchronous and Asynchronous serial Receiver and Transmitter (USART) is a fast and flexible serial communication peripheral. The USART supports several different modes of operation that can accommodate multiple types of applications and communication devices. For example, the One-Wire Half-Duplex mode is useful when low pin count applications are desired. The communication is frame-based, and the frame format can be customized to support a wide range of standards.

The USART is buffered in both directions, enabling continued data transmission without any delay between frames. Separate interrupts for receive and transmit completion allow fully interrupt-driven communication.

The transmitter consists of a two-level write buffer, a shift register, and control logic for different frame formats. The receiver consists of a two-level receive buffer and a shift register. The status information of the received data is available for error checking. Data and clock recovery units ensure robust synchronization and noise filtering during asynchronous data reception.

24.2.1 Block Diagram

Figure 24-1. USART Block Diagram

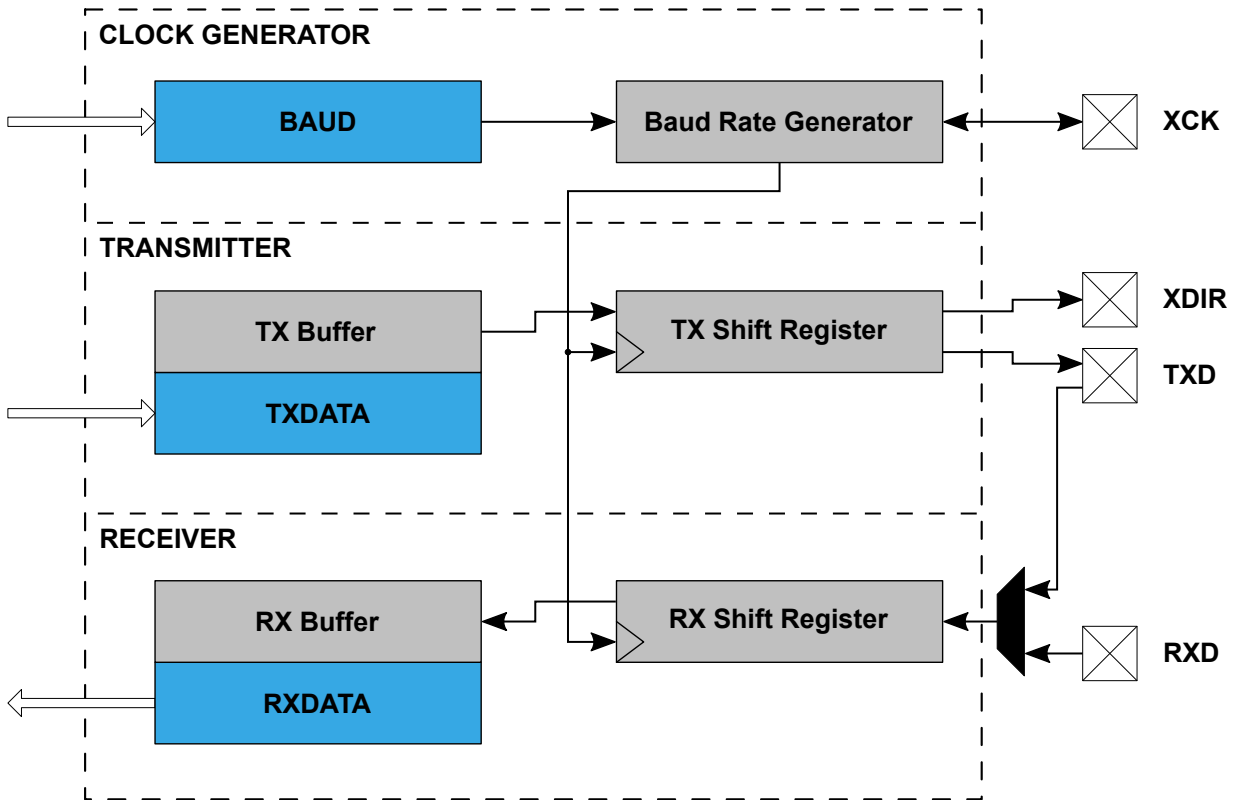

24.2.2 Signal Description

Signal	Type	Description
XCK	Output/input	Clock for synchronous operation
XDIR	Output	Transmit enable for RS-485
TxD	Output/input	Transmitting line (and receiving line in One-Wire mode)
RxD	Input	Receiving line

24.3 Functional Description

24.3.1 Initialization

Full-Duplex Mode:

1. Set the baud rate (USARTn.BAUD).
2. Set the frame format and mode of operation (USARTn.CTRLA).
3. Configure the TXD pin as an output.
4. Enable the transmitter and the receiver (USARTn.CTRLB).

Notes:

- For interrupt-driven USART operation, global interrupts must be disabled during the initialization
- Before doing a reinitialization with a changed baud rate or frame format, be sure that there are no ongoing transmissions while the registers are changed

One-Wire Half-Duplex Mode:

1. Internally connect the TXD to the USART receiver (the LBME bit in the USARTn.CTRLA register).
2. Enable internal pull-up for the RX/TX pin (the PULLUPEN bit in the PORTx.PINnCTRL register).
3. Enable Open-Drain mode (the ODME bit in the USARTn.CTRLB register).
4. Set the baud rate (USARTn.BAUD).
5. Set the frame format and mode of operation (USARTn.CTRLC).
6. Enable the transmitter and the receiver (USARTn.CTRLB).

Notes:

- When Open-Drain mode is enabled, the TXD pin is automatically set to output by hardware
- For interrupt-driven USART operation, global interrupts must be disabled during the initialization
- Before doing a reinitialization with a changed baud rate or frame format, be sure that there are no ongoing transmissions while the registers are changed

24.3.2 Operation

24.3.2.1 Frame Formats

The USART data transfer is frame-based. A frame starts with a Start bit followed by one character of data bits. If enabled, the Parity bit is inserted after the data bits and before the first Stop bit. After the Stop bit(s) of a frame, either the next frame can follow immediately, or the communication line can return to the Idle (high) state. The USART accepts all combinations of the following as valid frame formats:

- 1 Start bit
- 5, 6, 7, 8, or 9 data bits
- No, even, or odd Parity bit
- 1 or 2 Stop bits

The figure below illustrates the possible combinations of frame formats. Bits inside brackets are optional.

Figure 24-2. Frame Formats

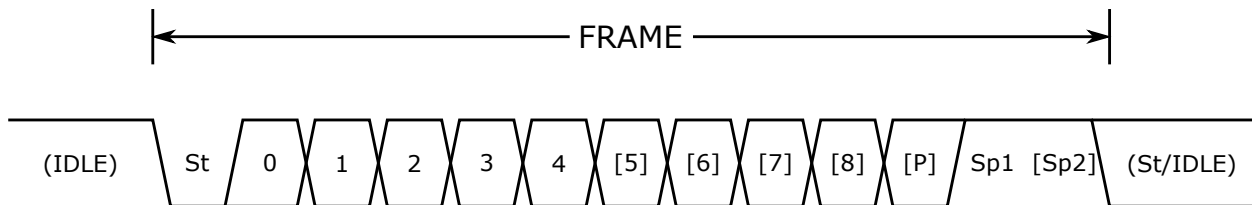

St Start bit, always low

(n) Data bits (0 to 8)

P Parity bit, may be odd or even

Sp Stop bit, always high

IDLE No transfer on the communication line (RxD or TxD). The Idle state is always high.

24.3.2.2 Clock Generation

The clock used for shifting and sampling data bits is generated internally by the fractional baud rate generator or externally from the Transfer Clock (XCK) pin.

Figure 24-3. Clock Generation Logic Block Diagram

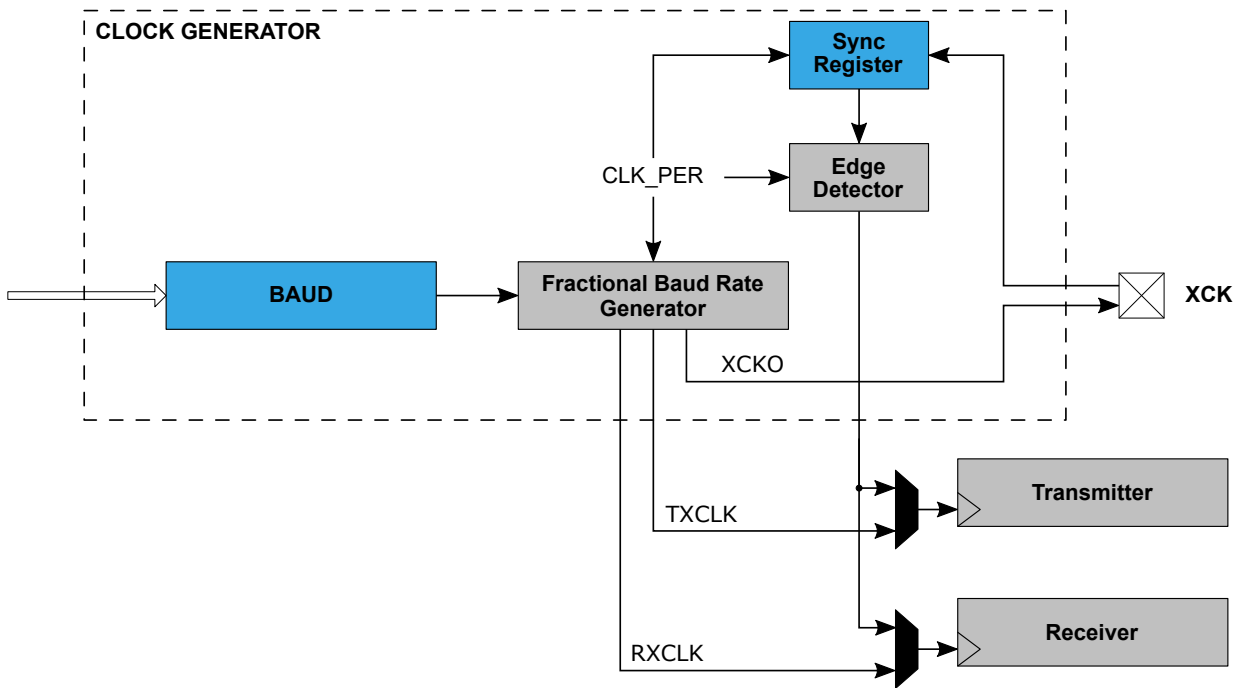

24.3.2.2.1 The Fractional Baud Rate Generator

In modes where the USART is not using the XCK input as a clock source, the fractional Baud Rate Generator is used to generate the clock. Baud rate is given in terms of bits per second (bps) and is configured by writing the USARTn.BAUD register. The baud rate (f_{BAUD}) is generated by dividing the peripheral clock (f_{CLK_PER}) by a division factor decided by the BAUD register.

The fractional Baud Rate Generator features hardware that accommodates cases where f_{CLK_PER} is not divisible by f_{BAUD} . Usually, this situation would lead to a rounding error. The fractional Baud Rate Generator expects the BAUD register to contain the desired division factor left shifted by six bits, as implemented by the equations in Table 24-1. The six Least Significant bits (LSbs) will then hold the fractional part of the desired divisor. Use the fractional part of the BAUD register to dynamically adjust f_{BAUD} to achieve a closer approximation to the desired baud rate.

Since the baud rate cannot be higher than f_{CLK_PER} , the integer part of the BAUD register needs to be at least 1. Since the result is left shifted by six bits, the corresponding minimum value of the BAUD register is 64. The valid range is, therefore, 64 to 65535.

In Synchronous mode, only the 10-bit integer part of the BAUD register (BAUD[15:6]) determines the baud rate, and the fractional part (BAUD[5:0]) must, therefore, be written to zero.

The table below lists equations for translating baud rates into input values for the BAUD register. The equations consider fractional interpretation, so the BAUD values calculated with these equations can be written directly to USARTn.BAUD without any additional scaling.

Table 24-1. Equations for Calculating Baud Rate Register Setting

Operating Mode	Conditions	Baud Rate (Bits Per Seconds)	USART.BAUD Register Value Calculation
Asynchronous	$f_{BAUD} \leq \frac{f_{CLK_PER}}{S}$ $USART.BAUD \geq 64$	$f_{BAUD} = \frac{64 \times f_{CLK_PER}}{S \times BAUD}$	$BAUD = \frac{64 \times f_{CLK_PER}}{S \times f_{BAUD}}$
Synchronous Host	$f_{BAUD} \leq \frac{f_{CLK_PER}}{S}$ $USART.BAUD \geq 64$	$f_{BAUD} = \frac{f_{CLK_PER}}{S \times BAUD[15:6]}$	$BAUD[15:6] = \frac{f_{CLK_PER}}{S \times f_{BAUD}}$

S is the number of samples per bit

- Asynchronous Normal mode: S = 16
- Asynchronous Double-Speed mode: S = 8
- Synchronous mode: S = 2

24.3.2.3 Data Transmission

The USART transmitter sends data by periodically driving the transmission line low. The data transmission is initiated by loading the Transmit Data (USARTn.TXDATAL and USARTn.TXDATAH) registers with the data to be sent. The data in the Transmit Data registers are moved to the TX Buffer once it is empty and onwards to the shift register once it is empty and ready to send a new frame. After the shift register is loaded with data, the data frame will be transmitted.

When the entire frame in the shift register has been shifted out, and there are no new data present in the Transmit Data registers or the TX Buffer, the Transmit Complete Interrupt Flag (the TXCIF bit in the USARTn.STATUS register) is set, and the interrupt is generated if it is enabled.

The Transmit Data registers can only be written when the Data Register Empty Interrupt Flag (the DREIF bit in the USARTn.STATUS register) is set, indicating that they are empty and ready for new data.

When using frames with fewer than eight bits, the Most Significant bits (MSBs) written to the Transmit Data registers are ignored. When the Character Size (CHSIZE) bit field in the Control C (USARTn.CTRLc) register is configured to 9-bit (low byte first), the Transmit Data Register Low Byte (TXDATAL) must be written before the Transmit Data Register High Byte (TXDATAH). When CHSIZE is configured to 9-bit (high byte first), TXDATAH must be written before TXDATAL.

24.3.2.3.1 Disabling the Transmitter

When disabling the transmitter, the operation will not become effective until ongoing and pending transmissions are completed. That is, when the transmit shift register, Transmit Data (USARTn.TXDATAL and USARTn.TXDATAH) registers, and TX Buffer register do not contain data to be transmitted. When the transmitter is disabled, it will no longer override the TXD pin, and the PORT module regains control of the pin. The pin is automatically configured as an input by hardware regardless of its previous setting. The pin can now be used as a normal I/O pin with no port override from the USART.

24.3.2.4 Data Reception

The USART receiver samples the reception line to detect and interpret the received data. The direction of the pin must, therefore, be configured as an input by writing a '0' to the corresponding bit in the Data Direction (PORTx.DIR) register.

The receiver accepts data when a valid Start bit is detected. Each bit that follows the Start bit will be sampled at the baud rate or XCK clock and shifted into the receive shift register until the first Stop bit of a frame is received. A second Stop bit will be ignored by the receiver. When the first Stop bit is received, and a complete serial frame is present in the receive shift register, the contents of the shift register will be moved into the receive buffer. The Receive Complete Interrupt Flag (the RXCIF bit in the USARTn.STATUS register) is set, and the interrupt is generated if enabled.

The RXDATA registers are the part of the double-buffered RX buffer that can be read by the application software when RXCIF is set. If only one frame has been received, the data and status bits for that frame are pushed to the RXDATA registers directly. If two frames are present in the RX buffer, the RXDATA registers contain the data for the oldest frame.

The buffer shifts out the data either when RXDATAL or RXDATAH is read, depending on the configuration. The register, which does not lead to data being shifted, must be read first to be able to read both bytes before shifting. When the Character Size (CHSIZE) bit field in the Control C (USARTn.CTRLc) register is configured to 9-bit (low byte first), a read of RXDATAH shifts the receive buffer. Otherwise, RXDATAL shifts the buffer.

24.3.2.4.1 Receiver Error Flags

The USART receiver features error detection mechanisms that uncover any corruption of the transmission. These mechanisms include the following:

- Frame Error detection - controls whether the received frame is valid
- Buffer Overflow detection - indicates data loss due to the receiver buffer being full and overwritten by the new data

- Parity Error detection - checks the validity of the incoming frame by calculating its parity and comparing it to the Parity bit

Each error detection mechanism controls one error flag that can be read in the RXDATAH register:

- Frame Error (FERR)
- Buffer Overflow (BUFOVF)
- Parity Error (PERR)

The error flags are located in the RX buffer together with their corresponding frame. The RXDATAH register that contains the error flags must be read before the RXDATAL register since reading the RXDATAL register will trigger the RX buffer to shift out the RXDATA bytes.

Note: If the Character Size (CHSIZE) bit field in the Control C (USARTn.CTRLA) register is set to nine bits, low byte first (9BITL), the RXDATAH register will, instead of the RXDATAL register, trigger the RX buffer to shift out the RXDATA bytes. The RXDATAL register must, in that case, be read before the RXDATAH register.

24.3.2.4.2 Disabling the Receiver

When disabling the receiver, the operation is immediate. The receiver buffer will be flushed, and data from ongoing receptions will be lost.

24.3.2.4.3 Flushing the Receive Buffer

If the RX buffer has to be flushed during normal operation, repeatedly read the DATA location (USARTn.RXDATAH and USARTn.RXDATAL registers) until the Receive Complete Interrupt Flag (the RXCIF bit in the USARTn.RXDATAH register) is cleared.

24.3.3 Communication Modes

The USART is a flexible peripheral that supports multiple different communication protocols. The available modes of operation can be split into two groups: Synchronous and asynchronous communication.

The synchronous communication relies on one device on the bus to be the host, providing the rest of the devices with a clock signal through the XCK pin. All the devices use this common clock signal for both transmission and reception, requiring no additional synchronization mechanism.

The device can be configured to run either as a host or a client on the synchronous bus.

The asynchronous communication does not use a common clock signal. Instead, it relies on the communicating devices to be configured with the same baud rate. When receiving a transmission, the hardware synchronization mechanisms are used to align the incoming transmission with the receiving device peripheral clock.

Four different modes of reception are available when communicating asynchronously. One of these modes can receive transmissions at twice the normal speed, sampling only eight times per bit instead of the normal 16. The other three operating modes use variations of synchronization logic, all receiving at normal speed.

24.3.3.1 Synchronous Operation

24.3.3.1.1 Clock Operation

The XCK pin direction controls whether the transmission clock is an input (Client mode) or an output (Host mode). The corresponding port pin direction must be set to output for Host mode or input for Client mode (PORTx.DIRn). The data input (on RXD) is sampled at the XCK clock edge, which is opposite the edge where data are transmitted (on TXD), as shown in the figure below.

Figure 24-4. Synchronous Mode XCK Timing

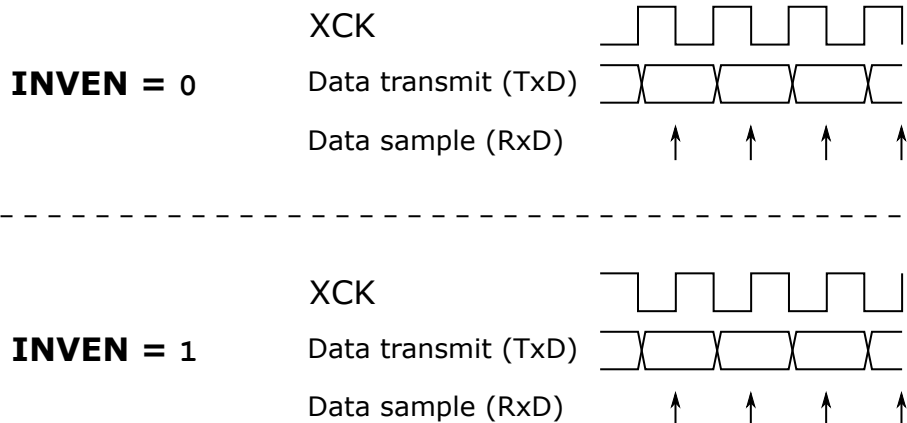

The I/O pin can be inverted by writing a '1' to the Inverted I/O Enable (INVEN) bit in the Pin n Control register of the port peripheral (PORTx.PINnCTRL). When using the inverted I/O setting for the corresponding XCK port pin, the XCK clock edges used for sampling RxD and transmitting on TxD can be selected. If the inverted I/O is disabled (INVEN = 0), the rising XCK clock edge represents the start of a new data bit, and the received data will be sampled at the falling XCK clock edge. If inverted I/O is enabled (INVEN = 1), the falling XCK clock edge represents the start of a new data bit, and the received data will be sampled at the rising XCK clock edge.

24.3.3.1.2 External Clock Limitations

When the USART is configured in Synchronous Client mode, the XCK signal must be provided externally by the host device. Since the clock is provided externally, configuring the BAUD register will have no impact on the transfer speed. Successful clock recovery requires the clock signal to be sampled at least twice for each rising and falling edge. The maximum XCK speed in Synchronous Operation mode, f_{Client_XCK} , is therefore limited by:

$$f_{Client_XCK} < \frac{f_{CLK_PER}}{4}$$

If the XCK clock has jitter, or if the high/low period duty cycle is not 50/50, the maximum XCK clock speed must be reduced accordingly to ensure that XCK is sampled a minimum of two times for each edge.

24.3.3.1.3 USART in Host SPI Mode

The USART may be configured to function with multiple different communication interfaces, and one of these is the Serial Peripheral Interface (SPI), where it can work as the host device. The SPI is a four-wire interface that enables a host device to communicate with one or multiple clients.

Frame Formats

The serial frame for the USART in Host SPI mode always contains eight Data bits. The Data bits can be configured to be transmitted with either the LSb or MSb first by writing to the Data Order (UDORD) bit in the Control C (USARTn.CTRLC) register.

SPI does not use Start, Stop, or Parity bits, so the transmission frame can only consist of the Data bits.

Clock Generation

Being a host device in a synchronous communication interface, the USART in Host SPI mode must generate the interface clock to be shared with the client devices. The interface clock is generated using the fractional Baud Rate Generator, which is described in [24.3.2.2.1. The Fractional Baud Rate Generator](#).

Each Data bit is transmitted by pulling the data line high or low for one full clock period. The receiver will sample bits in the middle of the transmitter hold period, as shown in the figure below. It also shows how the timing scheme can be configured using the Inverted I/O Enable (INVEN) bit in the PORTx.PINnCTRL register and the USART Clock Phase (UCPHA) bit in the USARTn.CTRLC register.

Figure 24-5. Data Transfer Timing Diagrams

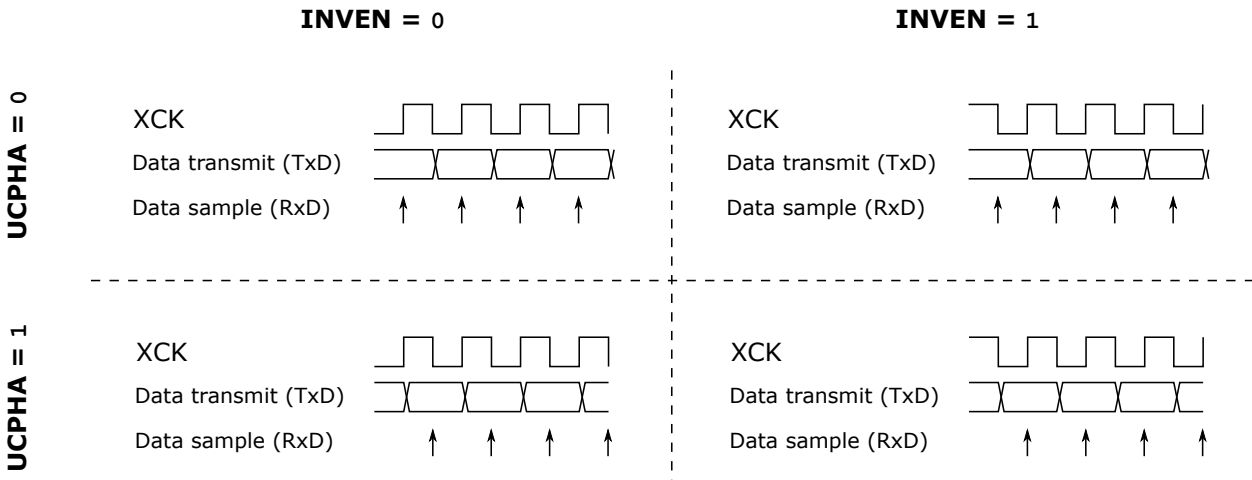

The table below further explains the figure above.

Table 24-2. Functionality of the INVEN and UCPHA Bits

INVEN	UCPHA	Leading Edge ⁽¹⁾	Trailing Edge ⁽¹⁾
0	0	Rising, sample	Falling, transmit
0	1	Rising, transmit	Falling, sample
1	0	Falling, sample	Rising, transmit
1	1	Falling, transmit	Rising, sample

Note:

1. The leading edge is the first clock edge of a clock cycle. The trailing edge is the last clock edge of a clock cycle.

Data Transmission

Data transmission in Host SPI mode is functionally identical to the general USART operation, as described in the *Operation* section. The transmitter interrupt flags and corresponding USART interrupts are also identical. See [24.3.2.3. Data Transmission](#) for further description.

Data Reception

Data reception in Host SPI mode is identical in function to general USART operation as described in the *Operation* section. The receiver interrupt flags and the corresponding USART interrupts are also identical, except for the receiver error flags that are not in use and always read as '0'. See [24.3.2.4. Data Reception](#) for further description.

USART in Host SPI Mode vs. SPI

The USART in Host SPI mode is fully compatible with a stand-alone SPI peripheral. Their data frame and timing configurations are identical. Some SPI specific special features are, however, not supported with the USART in Host SPI mode:

- Write Collision Flag Protection
- Double-Speed mode
- Multi-Host support

A comparison of the pins used with USART in Host SPI mode and with SPI is shown in the table below.

Table 24-3. Comparison of USART in Host SPI Mode and SPI Pins

USART	SPI	Comment
TXD	MOSI	Host out
RXD	MISO	Host in

.....continued		
USART	SPI	Comment
XCK	SCK	Functionally identical
-	\overline{SS}	Not supported by USART in Host SPI mode ⁽¹⁾

Note:

1. For the stand-alone SPI peripheral, this pin is used with the Multi-Host function or as a dedicated Client Select pin. The Multi-Host function is not available with the USART in Host SPI mode, and no dedicated Client Select pin is available.

24.3.3.2 Asynchronous Operation

24.3.3.2.1 Clock Recovery

Since there is no common clock signal when using Asynchronous mode, each communicating device generates separate clock signals. These clock signals must be configured to run at the same baud rate for the communication to take place. The devices, therefore, run at the same speed, but their timing is skewed in relation to each other. To accommodate this, the USART features a hardware clock recovery unit which synchronizes the incoming asynchronous serial frames with the internally generated baud rate clock.

The figure below illustrates the sampling process for the Start bit of an incoming frame. It shows the timing scheme for both Normal and Double-Speed mode (the RXMODE bit field in the USARTn.CTRLB register configured respectively to 0x00 and 0x01). The sample rate for Normal mode is 16 times the baud rate, while the sample rate for Double-Speed mode is eight times the baud rate (see 24.3.3.2.4. Double-Speed Operation for more details). The horizontal arrows show the maximum synchronization error. Note that the maximum synchronization error is larger in Double-Speed mode.

Figure 24-6. Start Bit Sampling

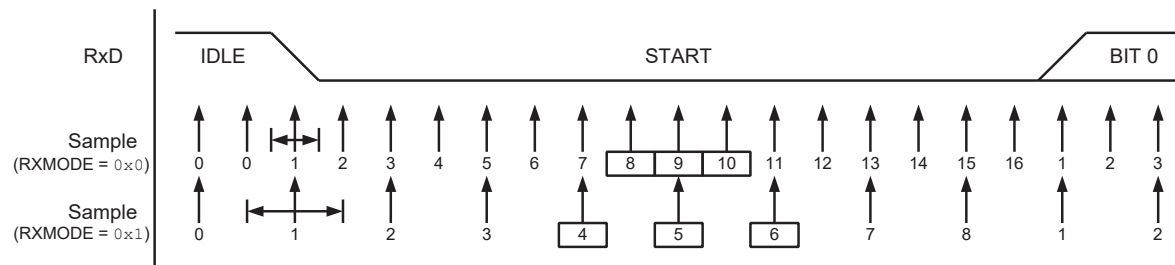

When the clock recovery logic detects a falling edge from the Idle (high) state to the Start bit (low), the Start bit detection sequence is initiated. In the figure above, sample 1 denotes the first sample reading '0'. The clock recovery logic then uses three subsequent samples (samples 8, 9, and 10 in Normal mode, and samples 4, 5, 6 in Double-Speed mode) to decide if a valid Start bit is received. If two or three samples read '0', the Start bit is accepted. The clock recovery unit is synchronized, and the data recovery can begin. If less than two samples read '0', the Start bit is rejected. This process is repeated for each Start bit.

24.3.3.2.2 Data Recovery

As with clock recovery, the data recovery unit samples at a rate 8 or 16 times faster than the baud rate depending on whether it is running in Double-Speed or Normal mode, respectively. The figure below shows the sampling process for reading a bit in a received frame.

Figure 24-7. Sampling of Data and Parity Bits

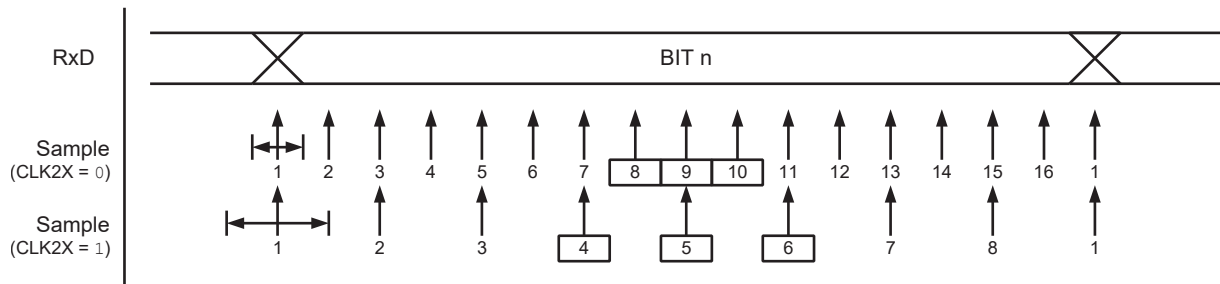

A majority voting technique is, like with clock recovery, used on the three center samples for deciding the logic level of the received bit. The process is repeated for each bit until a complete frame is received.

The data recovery unit will only receive the first Stop bit while ignoring the rest if there are more. If the sampled Stop bit is read '0', the Frame Error flag will be set. The figure below shows the sampling of a Stop bit. It also shows the earliest possible beginning of the next frame's Start bit.

Figure 24-8. Stop Bit and Next Start Bit Sampling

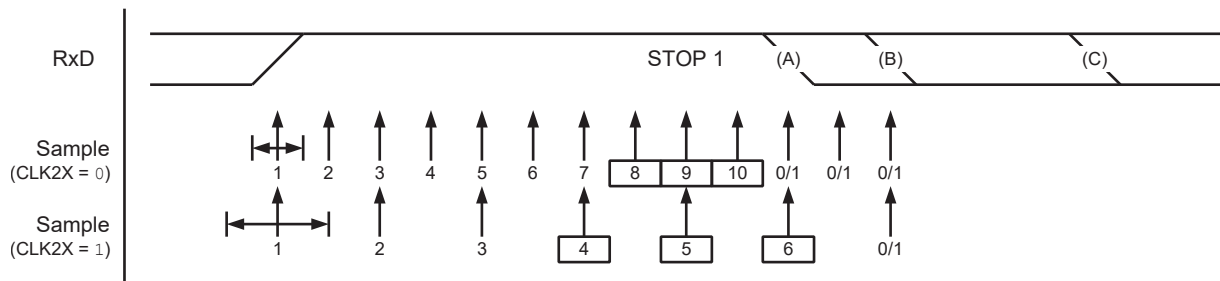

A new high-to-low transition indicating the Start bit of a new frame can come right after the last of the bits used for majority voting. For Normal-Speed mode, the first low-level sample can be at the point marked (A) in the figure above. For Double-Speed mode, the first low level must be delayed to point (B), being the first sample after the majority vote samples. Point (C) marks a Stop bit of full length at the nominal baud rate.

24.3.3.2.3 Error Tolerance

The speed of the internally generated baud rate and the externally received data rate has to be identical, but, due to natural clock source error, this is usually not the case. The USART is tolerant of such error, and the limits of this tolerance make up what is sometimes known as the Operational Range.

The following tables list the operational range of the USART, being the maximum receiver baud rate error that can be tolerated. Note that Normal-Speed mode has higher toleration of baud rate variations than Double-Speed mode.

Table 24-4. Recommended Maximum Receiver Baud Rate Error for Normal-Speed Mode

D	R _{slow} [%]	R _{fast} [%]	Maximum Total Error [%]	Recommended Max. Receiver Error [%]
5	93.20	106.67	-6.80/+6.67	±3.0
6	94.12	105.79	-5.88/+5.79	±2.5
7	94.81	105.11	-5.19/+5.11	±2.0
8	95.36	104.58	-4.54/+4.58	±2.0
9	95.81	104.14	-4.19/+4.14	±1.5
10	96.17	103.78	-3.83/+3.78	±1.5

Notes:

- D: The sum of character size and parity size (D = 5 to 10 bits)
- R_{SLOW}: The ratio of the slowest incoming data rate that can be accepted in relation to the receiver baud rate
- R_{FAST}: The ratio of the fastest incoming data rate that can be accepted in relation to the receiver baud rate

Table 24-5. Recommended Maximum Receiver Baud Rate Error for Double-Speed Mode

D	R _{slow} [%]	R _{fast} [%]	Maximum Total Error [%]	Recommended Max. Receiver Error [%]
5	94.12	105.66	-5.88/+5.66	±2.5
6	94.92	104.92	-5.08/+4.92	±2.0
7	95.52	104.35	-4.48/+4.35	±1.5
8	96.00	103.90	-4.00/+3.90	±1.5
9	96.39	103.53	-3.61/+3.53	±1.5
10	96.70	103.23	-3.30/+3.23	±1.0

Notes:

- D: The sum of character size and parity size (D = 5 to 10 bits)
- R_{SLOW}: The ratio of the slowest incoming data rate that can be accepted in relation to the receiver baud rate
- R_{FAST}: The ratio of the fastest incoming data rate that can be accepted in relation to the receiver baud rate

The recommendations of the maximum receiver baud rate error were made under the assumption that the receiver and transmitter equally divide the maximum total error.

The following equations are used to calculate the maximum ratio of the incoming data rate and the internal receiver baud rate.

$R_{SLOW} = \frac{S(D + 1)}{S(D + 1) + S_F - 1}$	$R_{FAST} = \frac{S(D + 2)}{S(D + 1) + S_M}$
--	--

- D: The sum of character size and parity size (D = 5 to 10 bits)
- S: Samples per bit. S = 16 for Normal-Speed mode and S = 8 for Double-Speed mode.
- S_F: First sample number used for majority voting. SF = 8 for Normal-Speed mode and SF = 4 for Double-Speed mode.
- S_M: Middle sample number used for majority voting. SM = 9 for Normal-Speed mode and SM = 5 for Double-Speed mode.
- R_{SLOW}: The ratio of the slowest incoming data rate that can be accepted in relation to the receiver baud rate
- R_{FAST}: The ratio of the fastest incoming data rate that can be accepted in relation to the receiver baud rate

24.3.3.2.4 Double-Speed Operation

The double-speed operation allows for higher baud rates under asynchronous operation with lower peripheral clock frequencies. This operation mode is enabled by writing the RXMODE bit field in the Control B (USARTn.CTRLB) register to 0x01.

When enabled, the baud rate for a given asynchronous baud rate setting will be doubled, as shown in the equations in 24.3.2.2.1. [The Fractional Baud Rate Generator](#). In this mode, the receiver will use half the number of samples (reduced from 16 to 8) for data sampling and clock recovery. This requires a more accurate baud rate setting and peripheral clock. See 24.3.3.2.3. [Error Tolerance](#) for more details.

24.3.3.2.5 Auto-Baud

The auto-baud feature lets the USART configure its BAUD register based on input from a communication device, which allows the device to communicate autonomously with multiple devices communicating with different baud rates. The USART peripheral features two auto-baud modes: Generic Auto-Baud mode and LIN Constrained Auto-Baud mode.

Both auto-baud modes must receive an auto-baud frame, as seen in the figure below.

Figure 24-9. Auto-Baud Timing

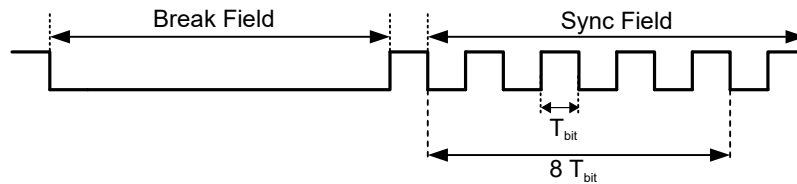

The break field is detected when 12 or more consecutive low cycles are sampled and notifies the USART that it is about to receive the synchronization field. After the break field, when the Start bit of the synchronization field is detected, a counter running at the peripheral clock speed is started. The counter is then incremented for the next eight T_{bit} of the synchronization field. When all eight bits are sampled, the counter is stopped. The resulting counter value is in effect the new BAUD register value.

When the USART Receive mode is set to GENAUTO (the RXMODE bit field in the USARTn.CTRLB register), the Generic Auto-Baud mode is enabled. In this mode, one can set the Wait For Break (WFB) bit in the USARTn.STATUS register to enable detection of a break field of any length (that is, also shorter than 12 cycles). This makes it possible to set an arbitrary new baud rate without knowing the current baud rate. If the measured sync field results in a valid BAUD value ($0x0064 - 0xFFFF$), the BAUD register is updated.

When USART Receive mode is set to LINAUTO mode (the RXMODE bit field in the USARTn.CTRLB register), it follows the LIN format. The WFB functionality of the Generic Auto-Baud mode is not compatible with the LIN Constrained Auto-Baud mode, which means that the received signal must be low for 12 peripheral clock cycles or more for a break field to be valid. When a break field has been detected, the USART expects the following synchronization field character to be $0x55$. If the received synchronization field character is not $0x55$, the Inconsistent Sync Field Error Flag (the ISFIF bit in the USARTn.STATUS register) is set, and the baud rate is unchanged.

24.3.3.2.6 Half-Duplex Operation

Half-duplex is a type of communication where two or more devices may communicate with each other, but only one at a time. The USART can be configured to operate in the following half-duplex modes:

- One-Wire mode
- RS-485 mode

One-Wire Mode

One-Wire mode is enabled by setting the Loop-Back Mode Enable (LBME) bit in the USARTn.CTRLA register. This will enable an internal connection between the TXD pin and the USART receiver, making the TXD pin a combined TxD/RxD line. The RXD pin will be disconnected from the USART receiver and may be controlled by a different peripheral.

In One-Wire mode, multiple devices can manipulate the TxD/RxD line at the same time. In the case where one device drives the pin to a logical high level (V_{CC}), and another device pulls the line low (GND), a short will occur. To accommodate this, the USART features an Open-Drain mode (the ODME bit in the USARTn.CTRLB register), which prevents the transmitter from driving a pin to a logical high level, thereby constraining it to only be able to pull it low. Combining this function with the internal pull-up feature (the PULLUPEN bit in the PORTx.PINnCTRL register) will let the line be held high through a pull-up resistor, allowing any device to pull it low. When the line is pulled low, the current from V_{CC} to GND will be limited by the pull-up resistor. The TXD pin is automatically set to output by hardware when the Open-Drain mode is enabled.

When the USART is transmitting to the TxD/RxD line, it will also receive its transmission. This can be used to detect overlapping transmissions by checking if the received data are the same as the transmitted data.

RS-485 Mode

RS-485 is a communication standard supported by the USART peripheral. It is a physical interface that defines the setup of a communication circuit. Data are transmitted using differential signaling, making communication robust against noise. RS-485 is enabled by writing the RS485 bit in the USARTn.CTRLA register to '1'.

The RS-485 mode supports external line driver devices that convert a single USART transmission into corresponding differential pair signals. It implements automatic control of the XDIR pin that can be used to enable transmission or reception for the line driver device. The USART automatically drives the XDIR pin high while the USART is transmitting and pulls it low when the transmission is complete. An example of such a circuit is shown in the figure below.

Figure 24-10. RS-485 Bus Connection

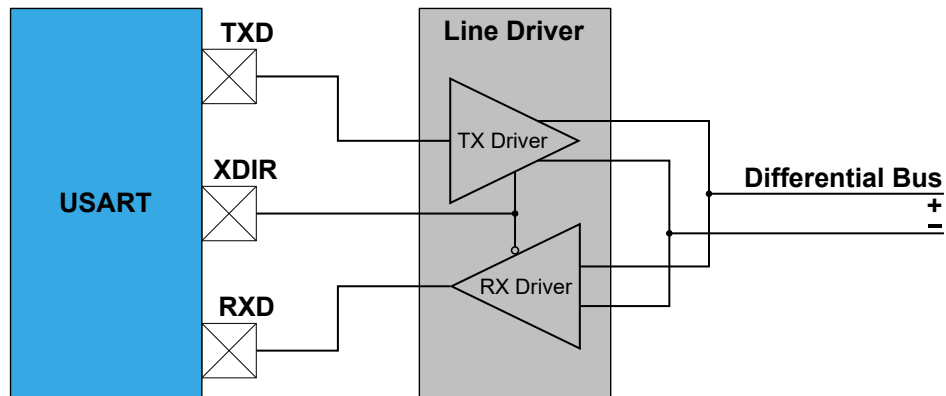

The XDIR pin goes high one baud clock cycle in advance of data being shifted out to allow some guard time to enable the external line driver. The XDIR pin will remain high for the complete frame, including Stop bit(s).

Figure 24-11. XDIR Drive Timing

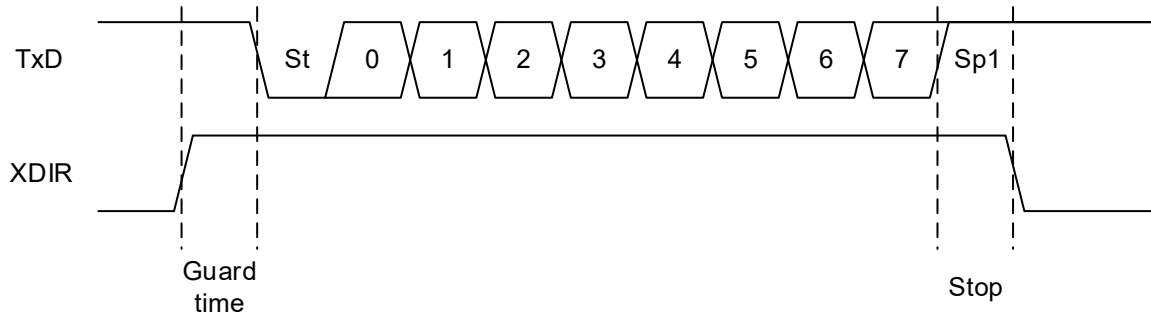

RS-485 mode is compatible with One-Wire mode. One-Wire mode enables an internal connection between the TXD pin and the USART receiver, making the TXD pin a combined TxD/RxD line. The RXD pin will be disconnected from the USART receiver and may be controlled by a different peripheral. An example of such a circuit is shown in the figure below.

Figure 24-12. RS-485 with Loop-Back Mode Connection

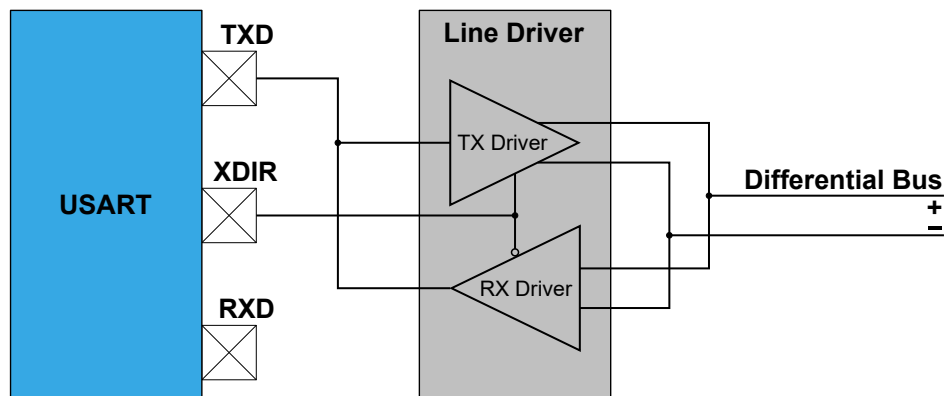

24.3.3.2.7 IRCOM Mode of Operation

The USART peripheral can be configured in Infrared Communication mode (IRCOM), which is IrDA® 1.4 compatible with baud rates up to 115.2 kbps. When enabled, the IRCOM mode enables infrared pulse encoding/decoding for the USART.

Figure 24-13. Block Diagram

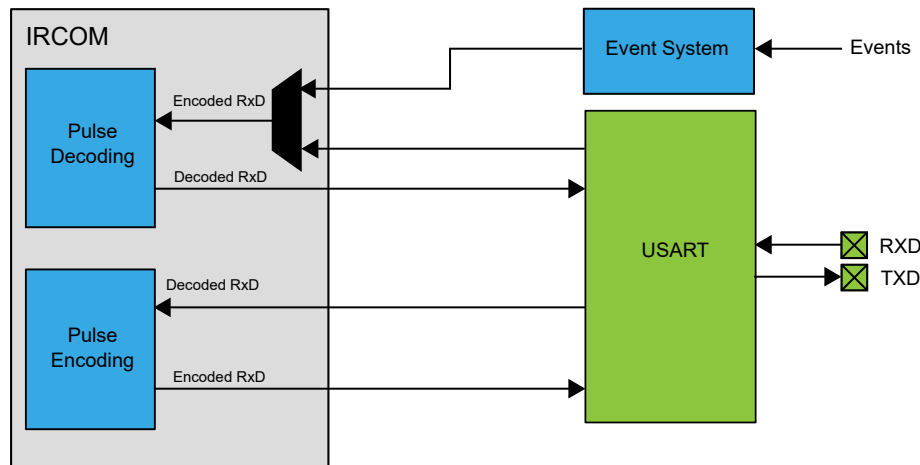

The USART is set in IRCOM mode by writing `0x02` to the CMODE bit field in the USARTn.CTRLC register. The data on the TXD/RXD pins are the inverted values of the transmitted/received infrared pulse. It is also possible to select an event channel from the Event System as an input for the IRCOM receiver. This enables the IRCOM to receive input from the I/O pins or sources other than the corresponding RXD pin, which will disable the RxD input from the USART pin.

For transmission, three pulse modulation schemes are available:

- 3/16 of the baud rate period
- Fixed programmable pulse time based on the peripheral clock frequency
- Pulse modulation disabled

For the reception, a fixed programmable minimum high-level pulse-width for the pulse to be decoded as a logical '0' is used. Shorter pulses will then be discarded, and the bit will be decoded to logical '1' as if no pulse was received.

Double-Speed mode cannot be used for the USART when IRCOM mode is enabled.

24.3.4 Additional Features

24.3.4.1 Parity

Parity bits can be used by the USART to check the validity of a data frame. The Parity bit is set by the transmitter based on the number of bits with the value of '1' in a transmission and controlled by the receiver upon reception. If the Parity bit is inconsistent with the transmission frame, the receiver may assume that the data frame has been corrupted.

Even or odd parity can be selected for error checking by writing the Parity Mode (PMODE) bit field in the USARTn.CTRLB register. If even parity is selected, the Parity bit is set to '1' if the number of Data bits with value '1' is odd (making the total number of bits with value '1' even). If odd parity is selected, the Parity bit is set to '1' if the number of data bits with value '1' is even (making the total number of bits with value '1' odd).

When enabled, the parity checker calculates the parity of the data bits in incoming frames and compares the result with the Parity bit of the corresponding frame. If a parity error is detected, the Parity Error flag (the PERR bit in the USARTn.RXDATAH register) is set.

If LIN Constrained Auto-Baud mode is enabled (`RXMODE = 0x03` in the USARTn.CTRLB register), a parity check is performed only on the protected identifier field. A parity error is detected if one of the equations below is not true, which sets the Parity Error flag.

$$P0 = ID0 \text{ XOR } ID1 \text{ XOR } ID2 \text{ XOR } ID4$$

$$P1 = \text{NOT} (ID1 \text{ XOR } ID3 \text{ XOR } ID4 \text{ XOR } ID5)$$

Figure 24-14. Protected Identifier Field and Mapping of Identifier and Parity Bits

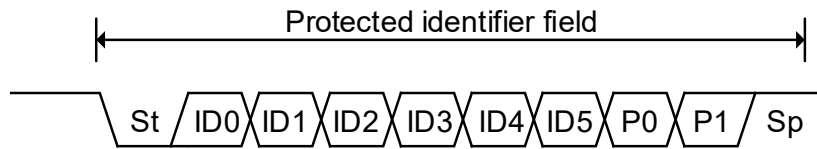

24.3.4.2 Start-of-Frame Detection

The Start-of-Frame Detection feature enables the USART to wake up from Standby sleep mode upon data reception.

When a high-to-low transition is detected on the RXD pin, the oscillator is powered up, and the USART peripheral clock is enabled. After start-up, the rest of the data frame can be received, provided that the baud rate is slow enough concerning the oscillator start-up time. The start-up time of the oscillators varies with supply voltage and temperature. For details on oscillator start-up time characteristics, refer to the *Electrical Characteristics* section.

If a false Start bit is detected, the device will, if another wake-up source has not been triggered, go back into the Standby sleep mode.

The Start-of-Frame detection works in Asynchronous mode only. It is enabled by writing the Start-of-Frame Detection Enable (SFDEN) bit in the USARTn.CTRLB register. If a Start bit is detected while the device is in Standby sleep mode, the USART Receive Start Interrupt Flag (RXSIF) bit is set.

The USART Receive Complete Interrupt Flag (RXCIF) bit and the RXSIF bit share the same interrupt line, but each has its dedicated interrupt settings. The table below shows the USART Start Frame Detection modes, depending on the interrupt setting.

Table 24-6. USART Start Frame Detection Modes

SFDEN	RXSIF Interrupt	RXCIF Interrupt	Comment
0	x	x	Standard mode
1	Disabled	Disabled	Only the oscillator is powered during the frame reception. If the interrupts are disabled and buffer overflow is ignored, all incoming frames will be lost
1	Disabled	Enabled	System/all clocks are awakened on Receive Complete interrupt
1	Enabled	x	System/all clocks are awakened when a Start bit is detected

Note: The SLEEP instruction will not shut down the oscillator if there is ongoing communication.

24.3.4.3 Multiprocessor Communication

The Multiprocessor Communication mode (MPCM) effectively reduces the number of incoming frames that have to be handled by the receiver in a system with multiple microcontrollers communicating via the same serial bus. This mode is enabled by writing a '1' to the MPCM bit in the Control B (USARTn.CTRLB) register. In this mode, a dedicated bit in the frames is used to indicate whether the frame is an address or data frame type.

If the receiver is set up to receive frames that contain five to eight data bits, the first Stop bit is used to indicate the frame type. If the receiver is set up for frames with nine data bits, the ninth bit is used to indicate frame type. When the frame type bit is '1', the frame contains an address. When the frame type bit is '0', the frame is a data frame. If 5- to 8-bit character frames are used, the transmitter must be set to use two Stop bits since the first Stop bit is used for indicating the frame type.

If a particular client MCU has been addressed, it will receive the following data frames as usual, while the other client MCUs will ignore the frames until another address frame is received.

24.3.4.3.1 Using Multiprocessor Communication

Use the following procedure to exchange data in Multiprocessor Communication mode (MPCM):

1. All client MCUs are in Multiprocessor Communication mode.
2. The host MCU sends an address frame, and all clients receive and read this frame.
3. Each client MCU determines if it has been selected.

4. The addressed MCU will disable MPCM and receive all data frames. The other client MCUs will ignore the data frames.
5. When the addressed MCU has received the last data frame, it must enable MPCM again and wait for a new address frame from the host.

The process then repeats from step 2.

24.3.5 Events

The USART can generate the events described in the table below.

Table 24-7. Event Generators in USART

Generator Name		Description	Event Type	Generating Clock Domain	Length of Event
Peripheral	Event				
USARTn	XCK	The clock signal in SPI Host mode and Synchronous USART Host mode	Pulse	CLK_PER	One XCK period

The table below describes the event user and its associated functionality.

Table 24-8. Event Users in USART

User Name		Description	Input Detection	Async/Sync
Peripheral	Input			
USARTn	IREI	USARTn IrDA event input	Pulse	Sync

24.3.6 Interrupts

Table 24-9. Available Interrupt Vectors and Sources

Name	Vector Description	Conditions
RXC	Receive Complete interrupt	<ul style="list-style-type: none"> • There is unread data in the receive buffer (RXCIE) • Receive of Start-of-Frame detected (RXSIE) • Auto-Baud Error/ISFIF flag set (ABEIE)
DRE	Data Register Empty interrupt	The transmit buffer is empty/ready to receive new data (DREIE)
TXC	Transmit Complete interrupt	The entire frame in the transmit shift register has been shifted out and there are no new data in the transmit buffer (TXCIE)

When an interrupt condition occurs, the corresponding interrupt flag is set in the STATUS (USARTn.STATUS) register.

An interrupt source is enabled or disabled by writing to the corresponding bit in the Control A (USARTn.CTRLA) register.

An interrupt request is generated when the corresponding interrupt source is enabled, and the Interrupt flag is set. The interrupt request remains active until the Interrupt flag is cleared. See the USARTn.STATUS register for details on how to clear Interrupt flags.

24.4 Register Summary

Offset	Name	Bit Pos.	7	6	5	4	3	2	1	0
0x00	RXDATA	7:0	DATA[7:0]							
0x01	RXDATAH	7:0	RXCIF	BUFOVF				FERR	PERR	DATA[8]
0x02	TXDATA	7:0	DATA[7:0]							
0x03	TXDATAH	7:0								DATA[8]
0x04	STATUS	7:0	RXCIF	TXCIF	DREIF	RXSIF	ISFIF		BDF	WFB
0x05	CTRLA	7:0	RXCIE	TXCIE	DREIE	RXSIE	LBME	ABEIE		RS485
0x06	CTRLB	7:0	RXEN	TXEN		SFDEN	ODME	RXMODE[1:0]		MPCM
0x07	CTRLC	7:0	CMODE[1:0]		PMODE[1:0]		SBMODE	CHSIZE[2:0]		
0x07	CTRLC	7:0	CMODE[1:0]					UDORD	UCPHA	
0x08	BAUD	7:0	BAUD[7:0]							
		15:8	BAUD[15:8]							
0x0A	CTRLD	7:0	ABW[1:0]							
0x0B	DBGCTRL	7:0								DBGRUN
0x0C	EVCTRL	7:0								IREI
0x0D	TXPLCTRL	7:0	TXPL[7:0]							
0x0E	RXPLCTRL	7:0								RXPL[6:0]

24.5 Register Description

24.5.1 Receiver Data Register Low Byte

Name: RXDATAL
Offset: 0x00
Reset: 0x00
Property: -

This register contains the eight LSbs of the data received by the USART receiver. The USART receiver is double-buffered, and this register always represents the data for the oldest received frame. If the data for only one frame is present in the receive buffer, this register contains that data.

The buffer shifts out the data either when RXDATAL or RXDATAH is read, depending on the configuration. The register, which does not lead to data being shifted, must be read first to be able to read both bytes before shifting.

When the Character Size (CHSIZE) bit field in the Control C (USARTn.CTRLA) register is configured to 9-bit (low byte first), a read of RXDATAH shifts the receive buffer, or else, RXDATAL shifts the buffer.

Bit	7	6	5	4	3	2	1	0
	DATA[7:0]							
Access	R	R	R	R	R	R	R	R
Reset	0	0	0	0	0	0	0	0

Bits 7:0 – DATA[7:0] Receiver Data Register

24.5.2 Receiver Data Register High Byte

Name: RXDATAH
Offset: 0x01
Reset: 0x00
Property: -

This register contains the MSb of the data received by the USART receiver, as well as status bits reflecting the status of the received data frame. The USART receiver is double-buffered, and this register always represents the data and status bits for the oldest received frame. If the data and status bits for only one frame is present in the receive buffer, this register contains that data.

The buffer shifts out the data either when RXDATAL or RXDATAH is read, depending on the configuration. The register, which does not lead to data being shifted, must be read first to be able to read both bytes before shifting.

When the Character Size (CHSIZE) bits in the Control C (USARTn.CTRLC) register is configured to 9-bit (low byte first), a read of RXDATAH shifts the receive buffer, or else, RXDATAL shifts the buffer.

Bit	7	6	5	4	3	2	1	0
	RXCIF	BUFOVF				FERR	PERR	DATA[8]
Access	R	R				R	R	R
Reset	0	0				0	0	0

Bit 7 – RXCIF USART Receive Complete Interrupt Flag

This flag is set when there are unread data in the receive buffer and cleared when the receive buffer is empty.

Bit 6 – BUFOVF Buffer Overflow

This flag is set if a buffer overflow is detected. A buffer overflow occurs when the receive buffer is full, a new frame is waiting in the receive shift register, and a new Start bit is detected. This flag is cleared when the Receiver Data (USARTn.RXDATAL and USARTn.RXDATAH) registers are read.

This flag is not used in the Host SPI mode of operation.

Bit 2 – FERR Frame Error

This flag is set if the first Stop bit is '0' and cleared when it is correctly read as '1'.

This flag is not used in the Host SPI mode of operation.

Bit 1 – PERR Parity Error

This flag is set if parity checking is enabled and the received data has a parity error, or else, this flag cleared. For details on parity calculation, refer to [24.3.4.1. Parity](#).

This flag is not used in the Host SPI mode of operation.

Bit 0 – DATA[8] Receiver Data Register

When using a 9-bit frame size, this bit holds the ninth bit (MSb) of the received data.

When the Receiver Mode (RXMODE) bit field in the Control B (USARTn.CTRLB) register is configured to LIN Constrained Auto-Baud (LINAUTO) mode, this bit indicates if the received data are within the response space of a LIN frame. This bit is cleared if the received data are in the protected identifier field and is otherwise set.

24.5.3 Transmit Data Register Low Byte

Name: TXDATAL
Offset: 0x02
Reset: 0x00
Property: -

The data written to this register is automatically loaded into the TX Buffer and through to the dedicated shift register. The shift register outputs each of the bits serially to the TXD pin.

When using a 9-bit frame size, the ninth bit (MSb) must be written to the Transmit Data Register High Byte (USARTn.TXDATAH). In that case, the buffer shifts data either when the Transmit Data Register Low Byte (USARTn.TXDATAL) or the Transmit Data Register High Byte (USARTn.TXDATAH) is written, depending on the configuration. The register, which does not lead to data being shifted, must be written first to be able to write both registers before shifting.

When the Character Size (CHSIZE) bit field in the Control C (USARTn.CTRLA) register is configured to 9-bit (low byte first), a write of the Transmit Data Register High Byte shifts the transmit buffer. Otherwise, the Transmit Data Register Low Byte shifts the buffer.

This register may only be written when the Data Register Empty Interrupt Flag (DREIF) in the Status (USARTn.STATUS) register is set.

Bit	7	6	5	4	3	2	1	0
	DATA[7:0]							
Access	R/W	R/W	R/W	R/W	R/W	R/W	R/W	R/W
Reset	0	0	0	0	0	0	0	0

Bits 7:0 – DATA[7:0] Transmit Data Register Low Byte

24.5.4 Transmit Data Register High Byte

Name: TXDATAH
Offset: 0x03
Reset: 0x00
Property: -

The data written to this register is automatically loaded into the TX Buffer and through to the dedicated shift register. The shift register outputs each of the bits serially to the TXD pin.

When using a 9-bit frame size, the ninth bit (MSb) must be written to the Transmit Data Register High Byte (USARTn.TXDATAH). In that case, the buffer shifts data either when the Transmit Data Register Low Byte (USARTn.TXDATAL) or the Transmit Data Register High Byte (USARTn.TXDATAH) is written, depending on the configuration. The register, which does not lead to data being shifted, must be written first to be able to write both registers before shifting.

When the Character Size (CHSIZE) bit field in the Control C (USARTn.CTRLA) register is configured to 9-bit (low byte first), a write of the Transmit Data Register High Byte shifts the transmit buffer. Otherwise, the Transmit Data Register Low Byte shifts the buffer.

This register may only be written when the Data Register Empty Interrupt Flag (DREIF) in the Status (USARTn.STATUS) register is set.

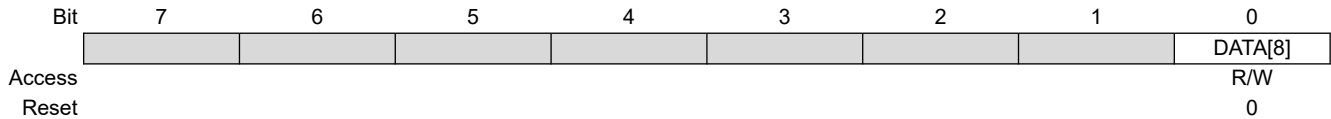

Bit 0 – DATA[8] Transmit Data Register High Byte

24.5.5 USART Status Register

Name: STATUS
Offset: 0x04
Reset: 0x00
Property: -

Bit	7	6	5	4	3	2	1	0
	RXCIF	TXCIF	DREIF	RXSIF	ISFIF		BDF	WFB
Access	R	R/W	R	R/W	R/W		R/W	W
Reset	0	0	1	0	0		0	0

Bit 7 – RXCIF USART Receive Complete Interrupt Flag

This flag is set when there are unread data in the receive buffer and cleared when the receive buffer is empty.

Bit 6 – TXCIF USART Transmit Complete Interrupt Flag

This flag is set when the entire frame in the transmit shift register has been shifted out, and there are no new data in the transmit buffer (TXDATAL and TXDATAH) registers. It is cleared by writing a '1' to it.

Bit 5 – DREIF USART Data Register Empty Interrupt Flag

This flag is set when the Transmit Data (USARTn.TXDATAL and USARTn.TXDATAH) registers are empty and cleared when they contain data that has not yet been moved into the transmit shift register.

Bit 4 – RXSIF USART Receive Start Interrupt Flag

This flag is set when Start-of-Frame detection is enabled, the device is in Standby sleep mode, and a valid start bit is detected. It is cleared by writing a '1' to it.

This flag is not used in the Host SPI mode operation.

Bit 3 – ISFIF Inconsistent Synchronization Field Interrupt Flag

This flag is set if an auto-baud mode is enabled, and the synchronization field is too short or too long to give a valid baud setting. It will also be set when USART is set to LIN AUTO mode, and the SYNC character differs from data value 0x55. This flag is cleared by writing a '1' to it. See the *Auto-Baud* section for more information.

Bit 1 – BDF Break Detected Flag

This flag is set if an auto-baud mode is enabled and a valid break and synchronization character is detected, and is cleared when the next data are received. It can also be cleared by writing a '1' to it. See the *Auto-Baud* section for more information.

Bit 0 – WFB Wait For Break

This bit controls whether the Wait For Break feature is enabled or not. Refer to the *Auto-Baud* section for more information.

Value	Description
0	Wait For Break is disabled
1	Wait For Break is enabled

24.5.6 Control A

Name: CTRLA
Offset: 0x05
Reset: 0x00
Property: -

Bit	7	6	5	4	3	2	1	0
	RXCIE	TXCIE	DREIE	RXSIE	LBME	ABEIE		RS485
Access	R/W	R/W	R/W	R/W	R/W	R/W		R/W
Reset	0	0	0	0	0	0		0

Bit 7 – RXCIE Receive Complete Interrupt Enable

This bit controls whether the Receive Complete Interrupt is enabled or not. When enabled, the interrupt will be triggered when the RXCIF bit in the USARTn.STATUS register is set.

Value	Description
0	The Receive Complete Interrupt is disabled
1	The Receive Complete Interrupt is enabled

Bit 6 – TXCIE Transmit Complete Interrupt Enable

This bit controls whether the Transmit Complete Interrupt is enabled or not. When enabled, the interrupt will be triggered when the TXCIF bit in the USARTn.STATUS register is set.

Value	Description
0	The Transmit Complete Interrupt is disabled
1	The Transmit Complete Interrupt is enabled

Bit 5 – DREIE Data Register Empty Interrupt Enable

This bit controls whether the Data Register Empty Interrupt is enabled or not. When enabled, the interrupt will be triggered when the DREIF bit in the USARTn.STATUS register is set.

Value	Description
0	The Data Register Empty Interrupt is disabled
1	The Data Register Empty Interrupt is enabled

Bit 4 – RXSIE Receiver Start Frame Interrupt Enable

This bit controls whether the Receiver Start Frame Interrupt is enabled or not. When enabled, the interrupt will be triggered when the RXSIF bit in the USARTn.STATUS register is set.

Value	Description
0	The Receiver Start Frame Interrupt is disabled
1	The Receiver Start Frame Interrupt is enabled

Bit 3 – LBME Loop-Back Mode Enable

This bit controls whether the Loop-back mode is enabled or not. When enabled, an internal connection between the TXD pin and the USART receiver is created, and the input from the RXD pin to the USART receiver is disconnected.

Value	Description
0	Loop-back mode is disabled
1	Loop-back mode is enabled

Bit 2 – ABEIE Auto-Baud Error Interrupt Enable

This bit controls whether the Auto-baud Error Interrupt is enabled or not. When enabled, the interrupt will be triggered when the ISFIF bit in the USARTn.STATUS register is set.

Value	Description
0	The Auto-Baud Error Interrupt is disabled
1	The Auto-Baud Error Interrupt is enabled

Bit 0 – RS485 RS-485 Mode

This bit controls whether the RS-485 mode is enabled or not. Refer to section [RS-485 Mode](#) for more information.

Value	Description
0	RS-485 mode is disabled
1	RS-485 mode is enabled

24.5.7 Control B

Name: CTRLB
Offset: 0x06
Reset: 0x00
Property: -

Bit	7	6	5	4	3	2	1	0
	RXEN	TXEN		SFDEN	ODME	RXMODE[1:0]		MPCM
Access	R/W	R/W		R/W	R/W	R/W	R/W	R/W
Reset	0	0		0	0	0	0	0

Bit 7 – RXEN Receiver Enable

This bit controls whether the USART receiver is enabled or not. Refer to [24.3.2.4.2. Disabling the Receiver](#) for more information.

Value	Description
0	The USART receiver is disabled
1	The USART receiver is enabled

Bit 6 – TXEN Transmitter Enable

This bit controls whether the USART transmitter is enabled or not. Refer to [24.3.2.3.1. Disabling the Transmitter](#) for more information.

Value	Description
0	The USART transmitter is disabled
1	The USART transmitter is enabled

Bit 4 – SFDEN Start-of-Frame Detection Enable

This bit controls whether the USART Start-of-Frame Detection mode is enabled or not. Refer to [24.3.4.2. Start-of-Frame Detection](#) for more information.

Value	Description
0	The USART Start-of-Frame Detection mode is disabled
1	The USART Start-of-Frame Detection mode is enabled

Bit 3 – ODME Open Drain Mode Enable

This bit controls whether Open Drain mode is enabled or not. See the [One-Wire Mode](#) section for more information.

Value	Description
0	Open Drain mode is disabled
1	Open Drain mode is enabled

Bits 2:1 – RXMODE[1:0] Receiver Mode

Writing this bit field selects the receiver mode of the USART.

- Writing the bits to 0x00 enables Normal-Speed (NORMAL) mode. When the USART Communication Mode (CMODE) bit field in the Control C (USARTn.CTRLC) register is configured to Asynchronous USART (ASYNCHRONOUS) or Infrared Communication (IRCOM), always write the RXMODE bit field to 0x00.
- Writing the bits to 0x01 enables Double-Speed (CLK2X) mode. Refer to [24.3.3.2.4. Double-Speed Operation](#) for more information.
- Writing the bits to 0x02 enables Generic Auto-Baud (GENAUTO) mode. Refer to the *Auto-Baud* section for more information.
- Writing the bits to 0x03 enables Lin Constrained Auto-Baud (LINAUTO) mode. Refer to the *Auto-Baud* section for more information.

Value	Name	Description
0x00	NORMAL	Normal-Speed mode
0x01	CLK2X	Double-Speed mode
0x02	GENAUTO	Generic Auto-Baud mode
0x03	LINAUTO	LIN Constrained Auto-Baud mode

Bit 0 – MPCM Multi-Processor Communication Mode

This bit controls whether the Multi-Processor Communication mode is enabled or not. Refer to [24.3.4.3. Multiprocessor Communication](#) for more information.

Value	Description
0	Multi-Processor Communication mode is disabled
1	Multi-Processor Communication mode is enabled

24.5.8 Control C - Normal Mode

Name: CTRLC
Offset: 0x07
Reset: 0x03
Property: -

This register description is valid for all modes except the Host SPI mode. When the USART Communication Mode (CMODE) bit field in this register is written to 'MSPI', see [CTRLC - Host SPI mode](#) for the correct description.

Bit	7	6	5	4	3	2	1	0
	CMODE[1:0]		PMODE[1:0]		SBMODE	CHSIZE[2:0]		
Access	R/W	R/W	R/W	R/W	R/W	R/W	R/W	R/W
Reset	0	0	0	0	0	0	1	1

Bits 7:6 – CMODE[1:0] USART Communication Mode

This bit field selects the communication mode of the USART.

Writing a 0x03 to these bits alters the available bit fields in this register. See [CTRLC - Host SPI mode](#).

Value	Name	Description
0x00	ASYNCHRONOUS	Asynchronous USART
0x01	SYNCHRONOUS	Synchronous USART
0x02	IRCOM	Infrared Communication
0x03	MSPI	Host SPI

Bits 5:4 – PMODE[1:0] Parity Mode

This bit field enables and selects the type of parity generation. See [24.3.4.1. Parity](#) for more information.

Value	Name	Description
0x0	DISABLED	Disabled
0x1	-	Reserved
0x2	EVEN	Enabled, even parity
0x3	ODD	Enabled, odd parity

Bit 3 – SBMODE Stop Bit Mode

This bit selects the number of Stop bits to be inserted by the transmitter.

The receiver ignores this setting.

Value	Description
0	1 Stop bit
1	2 Stop bits

Bits 2:0 – CHSIZE[2:0] Character Size

This bit field selects the number of data bits in a frame. The receiver and transmitter use the same setting. For 9BIT character size, the order of which byte to read or write first, low or high byte of RXDATA or TXDATA, can be configured.

Value	Name	Description
0x00	5BIT	5-bit
0x01	6BIT	6-bit
0x02	7BIT	7-bit
0x03	8BIT	8-bit
0x04	-	Reserved
0x05	-	Reserved
0x06	9BITL	9-bit (Low byte first)
0x07	9BITH	9-bit (High byte first)

24.5.9 Control C - Host SPI Mode

Name: CTRLC
Offset: 0x07
Reset: 0x00
Property: -

This register description is valid only when the USART is in Host SPI mode (CMODE written to MSPI). For other CMODE values, see [CTRLC - Normal Mode](#).

See [24.3.3.1.3. USART in Host SPI Mode](#) for a full description of the Host SPI mode operation.

Bit	7	6	5	4	3	2	1	0
	CMODE[1:0]					UDORD	UCPHA	
Access	R/W	R/W				R/W	R/W	
Reset	0	0				0	0	

Bits 7:6 – CMODE[1:0] USART Communication Mode

This bit field selects the communication mode of the USART.

Writing a value different than 0x03 to these bits alters the available bit fields in this register. See [CTRLC - Normal Mode](#).

Value	Name	Description
0x00	ASYNCHRONOUS	Asynchronous USART
0x01	SYNCHRONOUS	Synchronous USART
0x02	IRCOM	Infrared Communication
0x03	MSPI	Host SPI

Bit 2 – UDORD USART Data Order

This bit controls the frame format. The receiver and transmitter use the same setting. Changing the setting of the UDORD bit will corrupt all ongoing communication for both the receiver and the transmitter.

Value	Description
0	MSb of the data word is transmitted first
1	LSb of the data word is transmitted first

Bit 1 – UCPHA USART Clock Phase

This bit controls the phase of the interface clock. Refer to the [Clock Generation](#) section for more information.

Value	Description
0	Data are sampled on the leading (first) edge
1	Data are sampled on the trailing (last) edge

24.5.10 Baud Register

Name: BAUD
Offset: 0x08
Reset: 0x00
Property: -

The USARTn.BAUDL and USARTn.BAUDH register pair represents the 16-bit value, USARTn.BAUD. The low byte [7:0] (suffix L) is accessible at the original offset. The high byte [15:8] (suffix H) can be accessed at offset + 0x01.

Ongoing transmissions of the transmitter and receiver will be corrupted if the baud rate is changed. Writing to this register will trigger an immediate update of the baud rate prescaler. For more information on how to set the baud rate, see [Table 24-1](#).

Bit	15	14	13	12	11	10	9	8
	BAUD[15:8]							
Access	R/W	R/W	R/W	R/W	R/W	R/W	R/W	R/W
Reset	0	0	0	0	0	0	0	0
Bit	7	6	5	4	3	2	1	0
	BAUD[7:0]							
Access	R/W	R/W	R/W	R/W	R/W	R/W	R/W	R/W
Reset	0	0	0	0	0	0	0	0

Bits 15:8 – BAUD[15:8] USART Baud Rate High Byte
 This bit field holds the MSB of the 16-bit Baud register.

Bits 7:0 – BAUD[7:0] USART Baud Rate Low Byte
 This bit field holds the LSB of the 16-bit Baud register.

24.5.11 Control D

Name: CTRLD
Offset: 0x0A
Reset: 0x00
Property: -

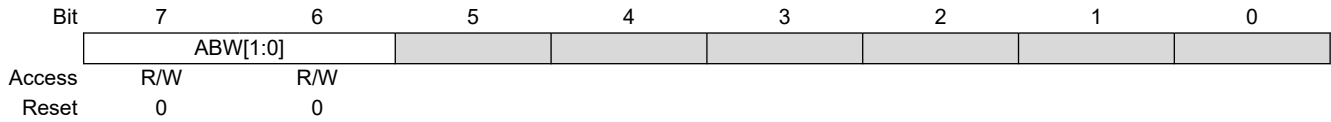

Bits 7:6 – ABW[1:0] Auto-Baud Window Size

These bits control the tolerance for the difference between the baud rates between the two synchronizing devices when using Lin Constrained Auto-baud mode. The tolerance is based on the number of baud samples between every two bits. When baud rates are identical, there must be 32 baud samples between each bit pair since each bit is sampled 16 times.

Value	Name	Description
0x00	WDW0	32±6 (18% tolerance)
0x01	WDW1	32±5 (15% tolerance)
0x02	WDW2	32±7 (21% tolerance)
0x03	WDW3	32±8 (25% tolerance)

24.5.12 Debug Control Register

Name: DBGCTRL
Offset: 0x0B
Reset: 0x00
Property: -

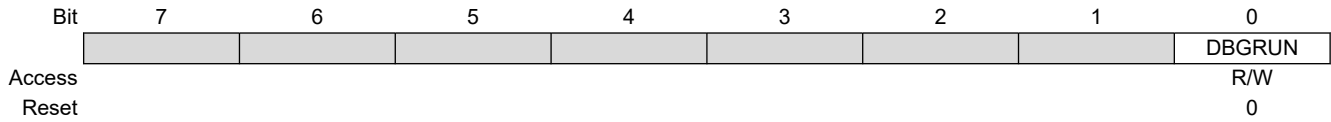

Bit 0 – DBGRUN Debug Run

Value	Description
0	The peripheral is halted in Break Debug mode and ignores events
1	The peripheral will continue to run in Break Debug mode when the CPU is halted

24.5.13 IrDA Control Register

Name: EVCTRL
Offset: 0x0C
Reset: 0x00
Property: -

Bit	7	6	5	4	3	2	1	0
								IREI
Access								R/W
Reset								0

Bit 0 – IREI IrDA Event Input Enable

This bit controls whether the IrDA event input is enabled or not. See [24.3.3.2.7. IRCOM Mode of Operation](#) for more information.

Value	Description
0	IrDA Event input is disabled
1	IrDA Event input is enabled

24.5.14 IRCOM Transmitter Pulse Length Control Register

Name: TXPLCTRL
Offset: 0x0D
Reset: 0x00
Property: -

Bit	7	6	5	4	3	2	1	0
	TXPL[7:0]							
Access	R/W	R/W	R/W	R/W	R/W	R/W	R/W	R/W
Reset	0	0	0	0	0	0	0	0

Bits 7:0 – TXPL[7:0] Transmitter Pulse Length

This 8-bit value sets the pulse modulation scheme for the transmitter. Setting this register will only have an effect if IRCOM mode is selected by the USART, and it must be configured before the USART transmitter is enabled (TXEN).

Value	Description
0x00	3/16 of the baud rate period pulse modulation is used
0x01– 0xFE	Fixed pulse length coding is used. The 8-bit value sets the number of peripheral clock periods for the pulse. The start of the pulse will be synchronized with the rising edge of the baud rate clock.
0xFF	Pulse coding disabled. RX and TX signals pass through the IRCOM module unaltered. This enables other features through the IRCOM module, such as half-duplex USART, loop-back testing, and USART RX input from an event channel.

24.5.15 IRCOM Receiver Pulse Length Control Register

Name: RXPLCTRL
Offset: 0x0E
Reset: 0x00
Property: -

Bit	7	6	5	4	3	2	1	0
		RXPL[6:0]						
Access		R/W	R/W	R/W	R/W	R/W	R/W	R/W
Reset		0	0	0	0	0	0	0

Bits 6:0 – RXPL[6:0] Receiver Pulse Length

This 7-bit value sets the filter coefficient for the IRCOM transceiver. Setting this register will only have an effect if IRCOM mode is selected by a USART, and it must be configured before the USART receiver is enabled (RXEN).

Value	Description
0x00	Filtering disabled
0x01– 0x7F	Filtering enabled. The value of RXPL+1 represents the number of samples required for a received pulse to be accepted.

25. SPI - Serial Peripheral Interface

25.1 Features

- Full Duplex, Three-Wire Synchronous Data Transfer
- Host or Client Operation
- LSb First or MSb First Data Transfer
- Seven Programmable Bit Rates
- End of Transmission Interrupt Flag
- Write Collision Flag Protection
- Wake-up from Idle Mode
- Double-Speed (CK/2) Host SPI Mode

25.2 Overview

The Serial Peripheral Interface (SPI) is a high-speed synchronous data transfer interface using three or four pins. It allows full-duplex communication between an AVR® device and peripheral devices or between several microcontrollers. The SPI peripheral can be configured as either host or client. The host initiates and controls all data transactions.

The interconnection between host and client devices with SPI is shown in the block diagram. The system consists of two shift registers and a server clock generator. The SPI host initiates the communication cycle by pulling the desired client's Client Select (\overline{SS}) signal low. The host and client prepare the data to be sent to their respective shift registers, and the host generates the required clock pulses on the SCK line to exchange data. Data are always shifted from host to client on the host output, client input (MOSI) line, and from client to host on the host input, client output (MISO) line.

25.2.1 Block Diagram

Figure 25-1. SPI Block Diagram

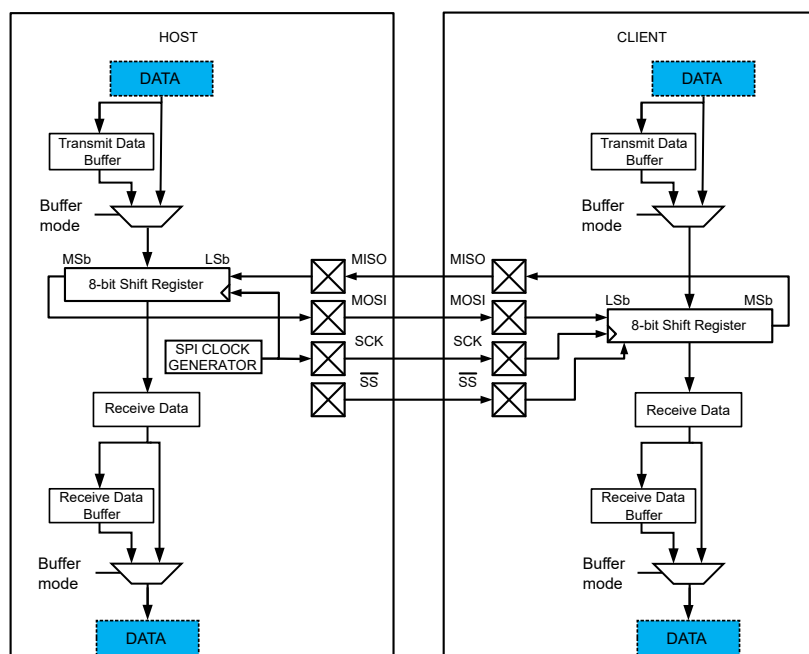

The SPI is built around an 8-bit shift register that will shift data out and in at the same time. The Transmit Data register and the Receive Data register are not physical registers but are mapped to other registers when written or

read: Writing the Transmit Data (SPIn.DATA) register will write the shift register in Normal mode and the Transmit Buffer register in Buffer mode. Reading the Receive Data (SPIn.DATA) register will read the Receive Data register in Normal mode and the Receive Data Buffer in Buffer mode.

In Host mode, the SPI has a clock generator to generate the SCK clock. In Client mode, the received SCK clock is synchronized and sampled to trigger the shifting of data in the shift register.

25.2.2 Signal Description

Table 25-1. Signals in Host and Client Mode

Signal	Description	Pin Configuration	
		Host Mode	Client Mode
MOSI	Host Out Client In	User defined ⁽¹⁾	Input
MISO	Host In Client Out	Input	User defined ^(1,2)
SCK	Serial Clock	User defined ⁽¹⁾	Input
\overline{SS}	Client Select	User defined ⁽¹⁾	Input

Notes:

1. If the pin data direction is configured as output, the pin level is controlled by the SPI.
2. If the SPI is in Client mode and the MISO pin data direction is configured as output, the \overline{SS} pin controls the MISO pin output in the following way:
 - If the \overline{SS} pin is driven low, the MISO pin is controlled by the SPI
 - If the \overline{SS} pin is driven high, the MISO pin is tri-stated

When the SPI module is enabled, the pin data direction for the signals marked with “Input” in [Table 25-1](#) is overridden.

25.3 Functional Description

25.3.1 Initialization

Initialize the SPI to a basic functional state by following these steps:

1. Configure the \overline{SS} pin in the port peripheral.
2. Select the SPI host/client operation by writing the Host/Client Select (MASTER) bit in the Control A (SPIn.CTRLA) register.
3. In Host mode, select the clock speed by writing the Prescaler (PRESC) bits and the Clock Double (CLK2X) bit in SPIn.CTRLA.
4. Optional: Select the Data Transfer mode by writing to the MODE bits in the Control B (SPIn.CTRLB) register.
5. Optional: Write the Data Order (DORD) bit in SPIn.CTRLA.
6. Optional: Set up the Buffer mode by writing the BUFEN and BUFWR bits in the Control B (SPIn.CTRLB) register.
7. Optional: To disable the multi-host support in Host mode, write ‘1’ to the Client Select Disable (SSD) bit in SPIn.CTRLB.
8. Enable the SPI by writing a ‘1’ to the ENABLE bit in SPIn.CTRLA.

25.3.2 Operation

25.3.2.1 Host Mode Operation

When the SPI is configured in Host mode, a write to the SPIn.DATA register will start a new transfer. The SPI host can operate in two modes, Normal and Buffer, as explained below.

25.3.2.1.1 Normal Mode

In Normal mode, the system is single-buffered in the transmit direction and double-buffered in the receive direction. This influences the data handling in the following ways:

1. New bytes to be sent cannot be written to the DATA (SPIn.DATA) register before the entire transfer has been completed. A premature write will cause corruption of the transmitted data, and the Write Collision (WRCOL) flag in SPIn.INTFLAGS will be set.
2. Received bytes are written to the Receive Data Buffer register immediately after the transmission is completed.
3. The Receive Data Buffer register has to be read before the next transmission is completed, or the data will be lost. This register is read by reading SPIn.DATA.
4. The Transmit Data Buffer and Receive Data Buffer registers are not used in Normal mode.

After a transfer has been completed, the Interrupt Flag (IF) will be set in the Interrupt Flags (SPIn.INTFLAGS) register. This will cause the corresponding interrupt to be executed if this interrupt and the global interrupts are enabled. Setting the Interrupt Enable (IE) bit in the Interrupt Control (SPIn.INTCTRL) register will enable the interrupt.

25.3.2.1.2 Buffer Mode

The Buffer mode is enabled by writing the BUFEN bit in the SPIn.CTRLB register to '1'. The BUFWR bit in SPIn.CTRLB does not affect Host mode. In Buffer mode, the system is double-buffered in the transmit direction and triple-buffered in the receive direction. This influences the data handling in the following ways:

1. New bytes can be written to the DATA (SPIn.DATA) register as long as the Data Register Empty Interrupt Flag (DREIF) in the Interrupt Flag (SPIn.INTFLAGS) register is set. The first write will be transmitted right away, and the following write will go to the Transmit Data Buffer register.
2. A received byte is placed in a two-entry Receive First-In, First-Out (RX FIFO) queue comprised of the Receive Data register and Receive Data Buffer immediately after the transmission is completed.
3. The DATA register is used to read from the RX FIFO. The RX FIFO must be read at least every second transfer to avoid any loss of data.

When both the shift register and the Transmit Data Buffer register become empty, the Transfer Complete Interrupt Flag (TXCIF) in the Interrupt Flags (SPIn.INTFLAGS) register will be set. This will cause the corresponding interrupt to be executed if this interrupt and the global interrupts are enabled. Setting the Transfer Complete Interrupt Enable (TXCIE) in the Interrupt Control (SPIn.INTCTRL) register enables the Transfer Complete Interrupt.

25.3.2.1.3 \overline{SS} Pin Functionality in Host Mode - Multi-Host Support

In Host mode, the Client Select Disable (SSD) bit in the Control B (SPIn.CTRLB) register controls how the SPI uses the \overline{SS} pin.

- If SSD in SPIn.CTRLB is '0', the SPI can use the \overline{SS} pin to transition from Host to Client mode. This allows multiple SPI hosts on the same SPI bus.
- If SSD in SPIn.CTRLB is '0', and the \overline{SS} pin is configured as an output pin, it can be used as a regular I/O pin or by other peripheral modules and will not affect the SPI system
- If SSD in SPIn.CTRLB is '1', the SPI does not use the \overline{SS} pin. It can be used as a regular I/O pin or by other peripheral modules.

If the SSD bit in SPIn.CTRLB is '0', and the \overline{SS} is configured as an input pin, the \overline{SS} pin must be held high to ensure Host SPI operation. A low level will be interpreted as another Host is trying to take control of the bus. This will switch the SPI into Client mode, and the hardware of the SPI will perform the following actions:

1. The Host (MASTER) bit in the SPI Control A (SPIn.CTRLA) register is cleared, and the SPI system becomes a client. The direction of the SPI pins will be switched when the conditions in [Table 25-2](#) are met.
2. The Interrupt Flag (IF) bit in the Interrupt Flags (SPIn.INTFLAGS) register will be set. If the interrupt is enabled and the global interrupts are enabled, the interrupt routine will be executed.

Table 25-2. Overview of the \overline{SS} Pin Functionality when the SSD Bit in SPIn.CTRLB is '0'

\overline{SS} Configuration	\overline{SS} Pin-Level	Description
Input	High	Host activated (selected)
	Low	Host deactivated, switched to Client mode
Output	High	Host activated (selected)
	Low	

Note: If the device is in Host mode and it cannot be ensured that the \overline{SS} pin will stay high between two transmissions, the status of the Host (MASTER) bit in SPIn.CTRLA has to be checked before a new byte is written. After the Host bit has been cleared by a low level on the \overline{SS} line, it must be set by the application to re-enable the SPI Host mode.

25.3.2.2 Client Mode

In Client mode, the SPI peripheral receives SPI clock and Client Select from a Host. Client mode supports three operational modes: One Normal mode and two configurations for the Buffered mode. In Client mode, the control logic will sample the incoming signal on the SCK pin. To ensure correct sampling of this clock signal, the minimum low and high periods must each be longer than two peripheral clock cycles.

25.3.2.2.1 Normal Mode

In Normal mode, the SPI peripheral will remain Idle as long as the \overline{SS} pin is driven high. In this state, the software may update the contents of the DATA register, but the data will not be shifted out by incoming clock pulses on the SCK pin until the \overline{SS} pin is driven low. If the \overline{SS} pin is driven low, the client will start to shift out data on the first SCK clock pulse. When one byte has been completely shifted, the SPI Interrupt Flag (IF) in SPIn.INTFLAGS is set.

The user application may continue placing new data to be sent into the DATA register before reading the incoming data. New bytes to be sent cannot be written to the DATA register before the entire transfer has been completed. A premature write will be ignored, and the hardware will set the Write Collision (WRCOL) flag in SPIn.INTFLAGS.

When the \overline{SS} pin is driven high, the SPI logic is halted, and the SPI client will not receive any new data. Any partially received packet in the shift register will be lost.

Figure 25-2 shows a transmission sequence in Normal mode. Notice how the value 0x45 is written to the DATA register but never transmitted.

Figure 25-2. SPI Timing Diagram in Normal Mode (Buffer Mode Not Enabled)

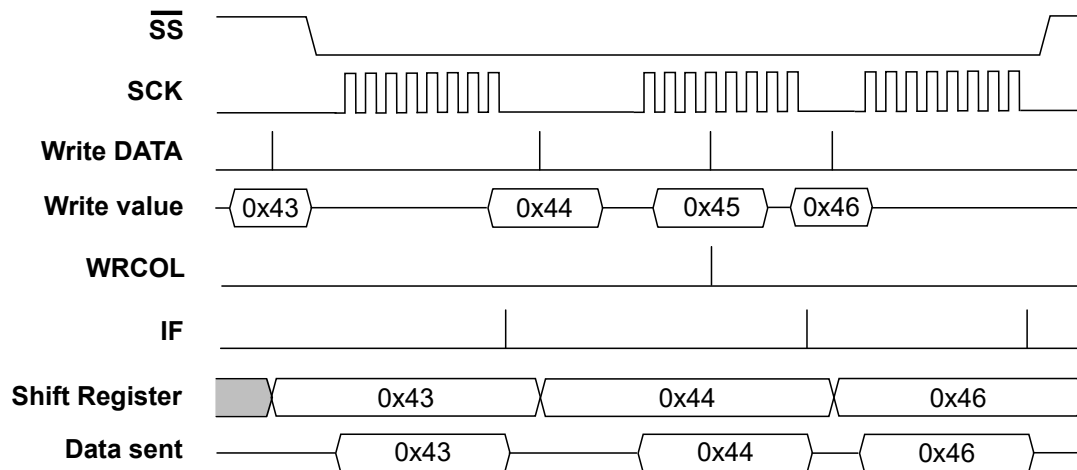

The figure above shows three transfers and one write to the DATA register while the SPI is busy with a transfer. This write will be ignored, and the Write Collision (WRCOL) flag in SPIn.INTFLAGS is set.

25.3.2.2.2 Buffer Mode

To avoid data collisions, the SPI peripheral can be configured in Buffered mode by writing a '1' to the Buffer Mode Enable (BUFEN) bit in the Control B (SPIn.CTRLB) register. In this mode, the SPI has additional interrupt flags and extra buffers. The extra buffers are shown in Figure 25-1. There are two different modes for the Buffer mode, selected with the Buffer mode Wait for Receive (BUFWR) bit. The two different modes are described below with timing diagrams.

Client Buffer Mode with Wait for Receive Bit Written to '0'

In Client mode, if the Buffer mode Wait for Receive (BUFWR) bit in SPIn.CTRLB is written to '0', a dummy byte will be sent before the transmission of user data starts. Figure 25-3 shows a transmission sequence with this configuration. Notice how the value 0x45 is written to the Data (SPIn.DATA) register but never transmitted.

Figure 25-3. SPI Timing Diagram in Buffer Mode with BUFWR in SPIn.CTRLB Written to '0'

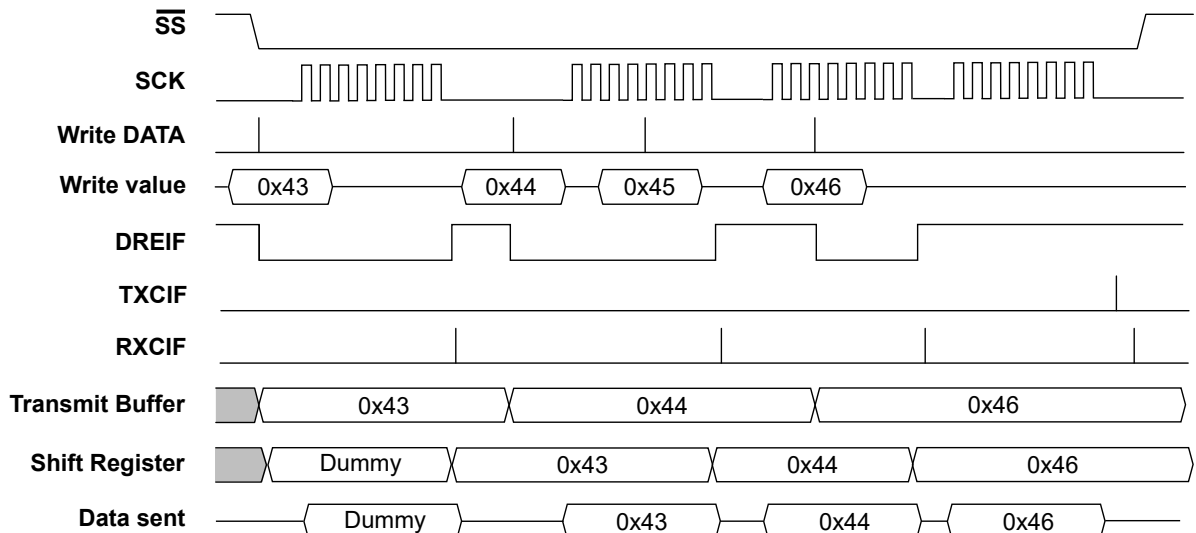

When the Wait for Receive (BUFWR) bit in SPIn.CTRLB is written to '0', all writes to the Data (SPIn.DATA) register go to the Transmit Data Buffer register. The figure above shows that the value 0x43 is written to the Data (SPIn.DATA) register but not immediately transferred to the shift register, so the first byte sent will be a dummy byte. The value of the dummy byte equals the values that were in the shift register at the same time. After the first dummy transfer is completed, the value 0x43 is transferred to the shift register. Then 0x44 is written to the Data (SPIn.DATA) register and goes to the Transmit Data Buffer register. A new transfer is started, and 0x43 will be sent. The value 0x45 is written to the Data (SPIn.DATA) register, but the Transmit Data Buffer register is not updated since it is already full containing 0x44 and the Data Register Empty Interrupt Flag (DREIF) in SPIn.INTFLAGS is low. The value 0x45 will be lost. After the transfer, the value 0x44 is moved to the shift register. During the next transfer, 0x46 is written to the Data (SPIn.DATA) register, and 0x44 is sent out. After the transfer is complete, 0x46 is copied into the shift register and sent out in the next transfer.

The DREIF goes low every time the Transmit Data Buffer register is written and goes high after a transfer when the previous value in the Transmit Data Buffer register is copied into the shift register. The Receive Complete Interrupt Flag (RXCIF) in SPIn.INTFLAGS is set one cycle after the DREIF goes high. The Transfer Complete Interrupt Flag is set one cycle after the Receive Complete Interrupt Flag is set when both the value in the shift register and in the Transmit Data Buffer register has been sent.

Client Buffer Mode with Wait for Receive Bit Written to '1'

In Client mode, if the Buffer mode Wait for Receive (BUFWR) bit in SPIn.CTRLB is written to '1', the transmission of user data starts as soon as the SS pin is driven low. [Figure 25-4](#) shows a transmission sequence with this configuration. Notice how the value 0x45 is written to the Data (SPIn.DATA) register but never transmitted.

Figure 25-4. SPI Timing Diagram in Buffer Mode with CTRLB.BUFWR Written to '1'

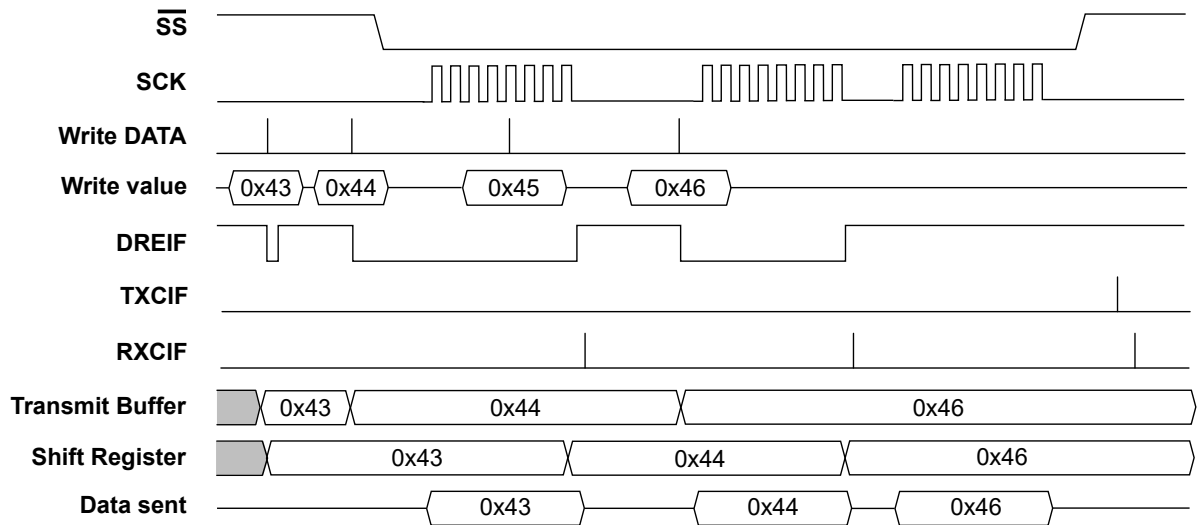

All writes to the Data (SPIn.DATA) register go to the Transmit Data Buffer register. The figure above shows that the value 0x43 is written to the Data (SPIn.DATA) register, and since the \overline{SS} pin is high, it is copied to the shift register in the next cycle. The next write (0x44) will go to the Transmit Data Buffer register. During the first transfer, the value 0x43 will be shifted out. In the figure above, the value 0x45 is written to the Data (SPIn.DATA) register, but the Transmit Data Buffer register is not updated since the DREIF is low. After the transfer is completed, the value 0x44 from the Transmit Data Buffer register is copied to the shift register. The value 0x46 is written to the Transmit Data Buffer register. During the next two transfers, 0x44 and 0x46 are shifted out. The flags behave identically to the Buffer Mode Wait for Receive (BUFWR) bit in SPIn.CTRLB set to '0'.

25.3.2.2.3 \overline{SS} Pin Functionality in Client Mode

The Client Select (\overline{SS}) pin plays a central role in the operation of the SPI. Depending on the SPI mode and the configuration of this pin, it can be used to activate or deactivate devices. The \overline{SS} pin is used as a Chip Select pin.

In Client mode, the \overline{SS} , MOSI, and SCK are always inputs. The behavior of the MISO pin depends on the configured data direction of the pin in the port peripheral and the value of \overline{SS} . When the \overline{SS} pin is driven low, the SPI is activated and will respond to received SCK pulses by clocking data out on MISO if the user has configured the data direction of the MISO pin as an output. When the \overline{SS} pin is driven high, the SPI is deactivated, meaning that it will not receive incoming data. If the MISO pin data direction is configured as an output, the MISO pin will be tri-stated. [Table 25-3](#) shows an overview of the \overline{SS} pin functionality.

Table 25-3. Overview of the \overline{SS} Pin Functionality

\overline{SS} Configuration	\overline{SS} Pin-Level	Description	MISO Pin Mode	
			Port Direction = Output	Port Direction = Input
Always Input	High	Client deactivated (deselected)	Tri-stated	Input
	Low	Client activated (selected)	Output	Input

Note: In Client mode, the SPI state machine will be reset when the \overline{SS} pin is driven high. If the \overline{SS} pin is driven high during a transmission, the SPI will stop sending and receiving data immediately and both data received and data sent must be considered lost. As the \overline{SS} pin is used to signal the start and end of a transfer, it is useful for achieving packet/byte synchronization and keeping the Client bit counter synchronized with the host clock generator.

25.3.2.3 Data Modes

There are four combinations of SCK phase and polarity concerning the serial data. The desired combination is selected by writing to the MODE bits in the Control B (SPIn.CTRLB) register.

The SPI data transfer formats are shown below. Data bits are shifted out and latched in on opposite edges of the SCK signal, ensuring sufficient time for data signals to stabilize.

The leading edge is the first clock edge of a clock cycle. The trailing edge is the last clock edge of a clock cycle.

Figure 25-5. SPI Data Transfer Modes

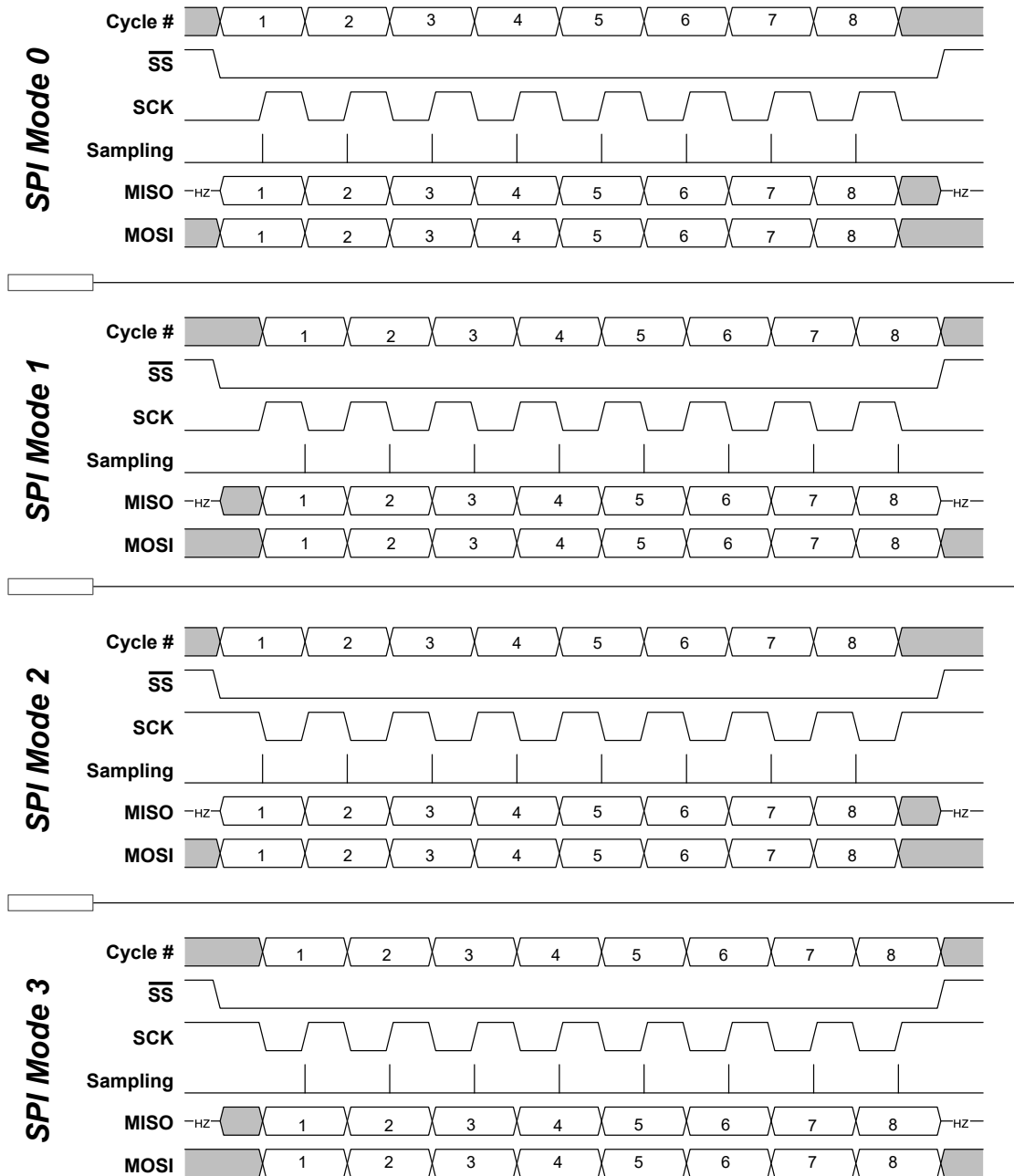

25.3.2.4 Events

The SPI can generate the following events:

Table 25-4. Event Generators in SPI

Generator Name		Description	Event Type	Generating Clock Domain	Length of Event
Module	Event				
SPIIn	SCK	SPI Host clock	Level	CLK_PER	Minimum two CLK_PER periods

The SPI has no event users.

Refer to the *Event System* section for more details regarding event types and Event System configuration.

25.3.2.5 Interrupts

Table 25-5. Available Interrupt Vectors and Sources

Name	Vector Description	Conditions	
		Normal Mode	Buffer Mode
SPIIn	SPI interrupt	<ul style="list-style-type: none"> • IF: Interrupt Flag interrupt • WRCOL: Write Collision interrupt 	<ul style="list-style-type: none"> • SSI: Client Select Trigger Interrupt • DRE: Data Register Empty interrupt • TXC: Transfer Complete interrupt • RXC: Receive Complete interrupt

When an interrupt condition occurs, the corresponding interrupt flag is set in the peripheral's Interrupt Flags (*peripheral.INTFLAGS*) register.

An interrupt source is enabled or disabled by writing to the corresponding enable bit in the peripheral's Interrupt Control (*peripheral.INTCTRL*) register.

An interrupt request is generated when the corresponding interrupt source is enabled, and the interrupt flag is set. The interrupt request remains active until the interrupt flag is cleared. See the peripheral's INTFLAGS register for details on how to clear interrupt flags.

25.4 Register Summary

Offset	Name	Bit Pos.	7	6	5	4	3	2	1	0
0x00	CTRLA	7:0		DORD	MASTER	CLK2X		PRESC[1:0]		ENABLE
0x01	CTRLB	7:0	BUFEN	BUFWR				SSD	MODE[1:0]	
0x02	INTCTRL	7:0	RXCIE	TXCIE	DREIE	SSIE				IE
0x03	INTFLAGS	7:0	IF	WRCOL						
0x03	INTFLAGS	7:0	RXCIF	TXCIF	DREIF	SSIF				BUFOVF
0x04	DATA	7:0	DATA[7:0]							

25.5 Register Description

25.5.1 Control A

Name: CTRLA
Offset: 0x00
Reset: 0x00
Property: -

	7	6	5	4	3	2	1	0
		DORD	MASTER	CLK2X		PRESC[1:0]		ENABLE
Access		R/W	R/W	R/W		R/W	R/W	R/W
Reset		0	0	0		0	0	0

Bit 6 – DORD Data Order

Value	Description
0	The MSb of the data word is transmitted first
1	The LSb of the data word is transmitted first

Bit 5 – MASTER Host/Client Select

This bit selects the desired SPI mode.

If \overline{SS} is configured as input and driven low while this bit is '1', then this bit is cleared, and the IF in SPIn.INTFLAGS is set. The user has to write MASTER = 1 again to re-enable SPI Host mode.

This behavior is controlled by the Client Select Disable (SSD) bit in SPIn.CTRLB.

Value	Description
0	SPI Client mode selected
1	SPI Host mode selected

Bit 4 – CLK2X Clock Double

When this bit is written to '1', the SPI speed (SCK frequency, after internal prescaler) is doubled in Host mode.

Value	Description
0	SPI speed (SCK frequency) is not doubled
1	SPI speed (SCK frequency) is doubled in Host mode

Bits 2:1 – PRESC[1:0] Prescaler

This bit field controls the SPI clock rate configured in Host mode. These bits have no effect in Client mode. The relationship between SCK and the peripheral clock frequency (f_{CLK_PER}) is shown below.

The output of the SPI prescaler can be doubled by writing the CLK2X bit to '1'.

Value	Name	Description
0x0	DIV4	CLK_PER/4
0x1	DIV16	CLK_PER/16
0x2	DIV64	CLK_PER/64
0x3	DIV128	CLK_PER/128

Bit 0 – ENABLE SPI Enable

Value	Description
0	SPI is disabled
1	SPI is enabled

25.5.2 Control B

Name: CTRLB
Offset: 0x01
Reset: 0x00
Property: -

	7	6	5	4	3	2	1	0
	BUFEN	BUFWR				SSD	MODE[1:0]	
Access	R/W	R/W				R/W	R/W	R/W
Reset	0	0				0	0	0

Bit 7 – BUFEN Buffer Mode Enable

Writing this bit to '1' enables Buffer mode. This will enable two receive buffers and one transmit buffer. Both will have separate interrupt flags, transmit complete and receive complete.

Bit 6 – BUFWR Buffer Mode Wait for Receive

When writing this bit to '0', the first data transferred will be a dummy sample.

Value	Description
0	One SPI transfer must be completed before the data are copied into the shift register
1	If writing to the Data register when the SPI is enabled and \overline{SS} is high, the first write will go directly to the shift register

Bit 2 – SSD Client Select Disable

If this bit is set when operating as SPI Host (MASTER = 1 in SPIn.CTRLA), \overline{SS} does not disable Host mode.

Value	Description
0	Enable the Client Select line when operating as SPI host
1	Disable the Client Select line when operating as SPI host

Bits 1:0 – MODE[1:0] Mode

These bits select the Transfer mode. The four combinations of SCK phase and polarity concerning the serial data are shown below. These bits decide whether the first edge of a clock cycle (leading edge) is rising or falling and whether data setup and sample occur on the leading or trailing edge. When the leading edge is rising, the SCK signal is low when idle, and when the leading edge is falling, the SCK signal is high when idle.

Value	Name	Description
0x0	0	Leading edge: Rising, sample Trailing edge: Falling, setup
0x1	1	Leading edge: Rising, setup Trailing edge: Falling, sample
0x2	2	Leading edge: Falling, sample Trailing edge: Rising, setup
0x3	3	Leading edge: Falling, setup Trailing edge: Rising, sample

25.5.3 Interrupt Control

Name: INTCTRL
Offset: 0x02
Reset: 0x00
Property: -

	7	6	5	4	3	2	1	0
	RXCIE	TXCIE	DREIE	SSIE				IE
Access	R/W	R/W	R/W	R/W				R/W
Reset	0	0	0	0				0

Bit 7 – RXCIE Receive Complete Interrupt Enable

In Buffer mode, this bit enables the Receive Complete interrupt. The enabled interrupt will be triggered when the RXCIF in the SPIn.INTFLAGS register is set. In the Non-Buffer mode, this bit is '0'.

Bit 6 – TXCIE Transfer Complete Interrupt Enable

In Buffer mode, this bit enables the Transfer Complete interrupt. The enabled interrupt will be triggered when the TXCIF in the SPIn.INTFLAGS register is set. In the Non-Buffer mode, this bit is '0'.

Bit 5 – DREIE Data Register Empty Interrupt Enable

In Buffer mode, this bit enables the Data Register Empty interrupt. The enabled interrupt will be triggered when the DREIF in the SPIn.INTFLAGS register is set. In the Non-Buffer mode, this bit is '0'.

Bit 4 – SSIE Client Select Trigger Interrupt Enable

In Buffer mode, this bit enables the Client Select interrupt. The enabled interrupt will be triggered when the SSIF in the SPIn.INTFLAGS register is set. In the Non-Buffer mode, this bit is '0'.

Bit 0 – IE Interrupt Enable

This bit enables the SPI interrupt when the SPI is not in Buffer mode. The enabled interrupt will be triggered when RXCIF/IF is set in the SPIn.INTFLAGS register.

25.5.4 Interrupt Flags - Normal Mode

Name: INTFLAGS
Offset: 0x03
Reset: 0x00
Property: -

	7	6	5	4	3	2	1	0
	IF	WRCOL						
Access	R/W	R/W						
Reset	0	0						

Bit 7 – IF Interrupt Flag

This flag is set when a serial transfer is complete, and one byte is completely shifted in/out of the SPIn.DATA register. If \overline{SS} is configured as input and is driven low when the SPI is in Host mode, this will also set this flag. The IF is cleared by hardware when executing the corresponding interrupt vector. Alternatively, the IF can be cleared by first reading the SPIn.INTFLAGS register when IF is set and then accessing the SPIn.DATA register.

Bit 6 – WRCOL Write Collision

The WRCOL flag is set if the SPIn.DATA register is written before a complete byte has been shifted out. This flag is cleared by first reading the SPIn.INTFLAGS register when WRCOL is set and then accessing the SPIn.DATA register.

25.5.5 Interrupt Flags - Buffer Mode

Name: INTFLAGS
Offset: 0x03
Reset: 0x00
Property: -

	7	6	5	4	3	2	1	0
Bit	RXCIF	TXCIF	DREIF	SSIF				BUFOVF
Access	R/W	R/W	R/W	R/W				R/W
Reset	0	0	0	0				0

Bit 7 – RXCIF Receive Complete Interrupt Flag

This flag is set when there are unread data in the Receive Data Buffer register and cleared when the Receive Data Buffer register is empty (that is, it does not contain any unread data).
 When interrupt-driven data reception is used, the Receive Complete Interrupt routine must read the received data from the DATA register to clear RXCIF. If not, a new interrupt will occur directly after the return from the current interrupt. This flag can also be cleared by writing a '1' to its bit location.

Bit 6 – TXCIF Transfer Complete Interrupt Flag

This flag is set when all the data in the Transmit shift register has been shifted out, and there is no new data in the transmit buffer (SPIn.DATA). The flag is cleared by writing a '1' to its bit location.

Bit 5 – DREIF Data Register Empty Interrupt Flag

This flag indicates whether the Transmit Data Buffer register is ready to receive new data. The flag is '1' when the transmit buffer is empty and '0' when the transmit buffer contains data to be transmitted that has not yet been moved into the shift register. The DREIF is cleared after a Reset to indicate that the transmitter is ready.
 The DREIF is cleared by writing to DATA. When interrupt-driven data transmission is used, the Data Register Empty Interrupt routine must either write new data to DATA to clear DREIF or disable the Data Register Empty interrupt. If not, a new interrupt will occur directly after the return from the current interrupt.

Bit 4 – SSIF Client Select Trigger Interrupt Flag

This flag indicates that the SPI has been in Host mode, and the \overline{SS} pin has been pulled low externally, so the SPI is now working in Client mode. The flag will only be set if the Client Select Disable (SSD) bit is not '1'. The flag is cleared by writing a '1' to its bit location.

Bit 0 – BUFOVF Buffer Overflow

This flag indicates data loss due to a Receive Data Buffer full condition. This flag is set if a Buffer Overflow condition is detected. A Buffer Overflow occurs when the receive buffer is full (two bytes), and a third byte has been received in the shift register. If there is no transmit data, the Buffer Overflow will not be set before the start of a new serial transfer. This flag is cleared when the DATA register is read or by writing a '1' to its bit location.

25.5.6 Data

Name: DATA
Offset: 0x04
Reset: 0x00
Property: -

	7	6	5	4	3	2	1	0
	DATA[7:0]							
Access	R/W	R/W	R/W	R/W	R/W	R/W	R/W	R/W
Reset	0	0	0	0	0	0	0	0

Bits 7:0 – DATA[7:0] SPI Data

The DATA register is used for sending and receiving data. Writing to the register initiates the data transmission when in Host mode while preparing data for sending in Client mode. The byte written to the register shifts out on the SPI output line when a transaction is initiated.

The SPIn.DATA register is not a physical register. Depending on what mode is configured, it is mapped to other registers, as described below.

- Normal mode:
 - Writing the DATA register will write the shift register
 - Reading from DATA will read from the Receive Data register
- Buffer mode:
 - Writing the DATA register will write to the Transmit Data Buffer register
 - Reading from DATA will read from the Receive Data Buffer register. The contents of the Receive Data register will then be moved to the Receive Data Buffer register.

26. TWI - Two-Wire Interface

26.1 Features

- Bidirectional, Two-Wire Communication Interface
- Philips I²C Compatible¹
 - Standard mode
 - Fast mode
 - Fast mode plus
- System Management Bus (SMBus) 2.0 Compatible
 - Support arbitration between Start/repeated Start and data bit
 - Client arbitration allows support for the Address Resolution Protocol (ARP)
 - Configurable SMBus Layer 1 time-outs in hardware
- Independent Host and Client Operation
 - Single or multi-host bus operation with full arbitration support
- Flexible Client Address Match Hardware Operating in All Sleep Modes, Including Power-Down
 - 7-bit and general call address recognition
 - 10-bit addressing support in collaboration with software
 - Support for address range masking or secondary address match
 - Optional software address recognition (permissive mode) for an unlimited number of addresses
- Input Filter for Bus Noise Suppression
- Smart Mode Support

26.2 Overview

The Two-Wire Interface (TWI) is a bidirectional, two-wire communication interface (bus) with a Serial Data Line (SDA) and a Serial Clock Line (SCL).

The TWI bus connects one or several client devices to one or several host devices. Any device connected to the bus can act as a host, a client, or both. The host generates the SCL by using a Baud Rate Generator (BRG) and initiates data transactions by addressing one client and telling whether it wants to transmit or receive data. The BRG is capable of generating the Standard mode (Sm) and Fast mode (Fm, Fm+) bus frequencies from 100 kHz up to 1 MHz.

The TWI will detect Start and Stop conditions, bus collisions, and bus errors. Arbitration lost, errors, collision, and clock hold are also detected and indicated in separate status flags available in both Host and Client modes.

The TWI supports multi-host bus operation and arbitration. An arbitration scheme handles the case where more than one host tries to transmit data at the same time. The TWI also supports Smart mode, which can auto-trigger operations and thus reduce software complexity. The TWI supports Quick Command mode, where the host can address a client without exchanging data.

¹ The I²C standard uses the terminology "host" and "client". The equivalent Microchip terminology used in this document is "host" and "client" respectively.

26.2.1 Block Diagram

Figure 26-1. TWI Block Diagram

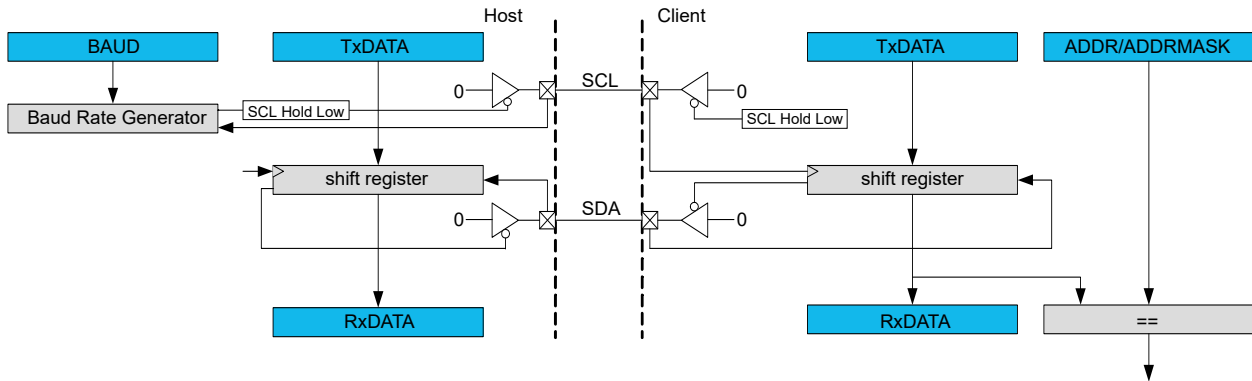

26.2.2 Signal Description

Signal	Description	Type
SCL	Serial Clock Line	Digital I/O
SDA	Serial Data Line	Digital I/O

26.3 Functional Description

26.3.1 General TWI Bus Concepts

The TWI provides a simple, bidirectional, two-wire communication bus consisting of:

- Serial Data Line (SDA) for packet transfer
- Serial Clock Line (SCL) for the bus clock

The two lines are open-collector lines (wired-AND).

The TWI bus topology is a simple and efficient method of interconnecting multiple devices on a serial bus. A device connected to the bus can be a host or a client. Only host devices can control the bus and the bus communication.

A unique address is assigned to each client device connected to the bus, and the host will use it to control the client and initiate a transaction. Several hosts can be connected to the same bus. This is called a multi-host environment. An arbitration mechanism is provided for resolving bus ownership among hosts since only one host device may own the bus at any given time.

A host indicates the start of a transaction by issuing a Start condition (S) on the bus. The host provides the clock signal for the transaction. An address packet with a 7-bit client address (ADDRESS) and a direction bit, representing whether the host wishes to read or write data (R/\bar{W}), are then sent.

The addressed I²C client will then acknowledge (ACK) the address, and data packet transactions can begin. Every 9-bit data packet consists of eight data bits followed by a 1-bit reply indicating whether the data was acknowledged or not by the receiver.

After all the data packets (DATA) are transferred, the host issues a Stop condition (P) on the bus to end the transaction.

Figure 26-2. Basic TWI Transaction Diagram Topology for a 7-Bit Address Bus

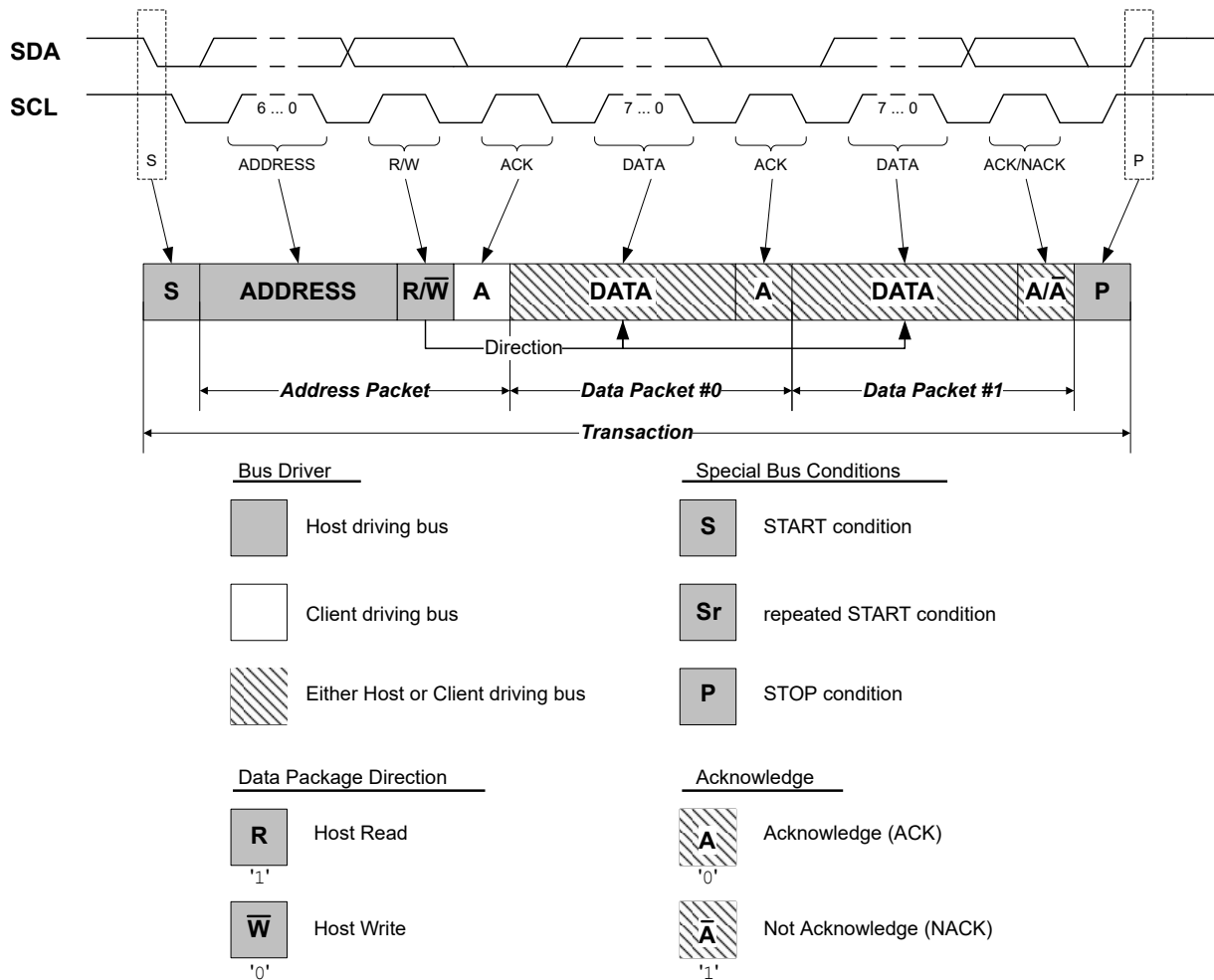

26.3.2 TWI Basic Operation

26.3.2.1 Initialization

If used, the following bits must be configured before enabling the TWI device:

- The SDA Hold Time (SDAHOLD) bit field from the Control A (TWIn.CTRLA) register
- The FM Plus Enable (FMPEN) bit from the Control A (TWIn.CTRLA) register

26.3.2.1.1 Host Initialization

Write the Host Baud Rate (TWIn.MBAUD) register to a value that will result in a valid TWI bus clock frequency.

Writing a '1' to the Enable TWI Host (ENABLE) bit in the Host Control A (TWIn.MCTRLA) register will enable the TWI host. The Bus State (BUSSTATE) bit field from the Host Status (TWIn.MSTATUS) register must be set to 0x1 to force the bus state to Idle.

26.3.2.1.2 Client Initialization

Follow these steps to initialize the client:

1. Before enabling the TWI device, configure the SDA Setup Time (SDASETUP) bit from the Control A (TWIn.CTRLA) register.
2. Write the address of the client to the Client Address (TWIn.SADDR) register.
3. Write a '1' to the Enable TWI Client (ENABLE) bit in the Client Control A (TWIn.SCTRLA) register to enable the TWI client.

The client device will now wait for a host device to issue a Start condition and the matching client address.

26.3.2.2 TWI Host Operation

The TWI host is byte-oriented, with an optional interrupt after each byte. There are separate interrupt flags for the host write and read operation. Interrupt flags can also be used for polled operation. There are dedicated status flags for indicating ACK/NACK received, bus error, arbitration lost, clock hold, and bus state.

When an interrupt flag is set to '1', the SCL is forced low. This will give the host time to respond or handle any data and will, in most cases, require software interaction. Clearing the interrupt flags releases the SCL. The number of interrupts generated is kept to a minimum by automatic handling of most conditions.

26.3.2.2.1 Clock Generation

The TWI supports several transmission modes with different frequency limitations:

- Standard mode (Sm) up to 100 kHz
- Fast mode (Fm) up to 400 kHz
- Fast mode Plus (Fm+) up to 1 MHz

Write the Host Baud Rate (TWIn.MBAUD) register to a value that will result in a TWI bus clock frequency equal to, or less than, those frequency limits, depending on the transmission mode.

The low (t_{LOW}) and high (t_{HIGH}) times are determined by the Host Baud Rate (TWIn.MBAUD) register, while the rise (t_R) and fall (t_{OF}) times are determined by the bus topology.

Figure 26-3. SCL Timing

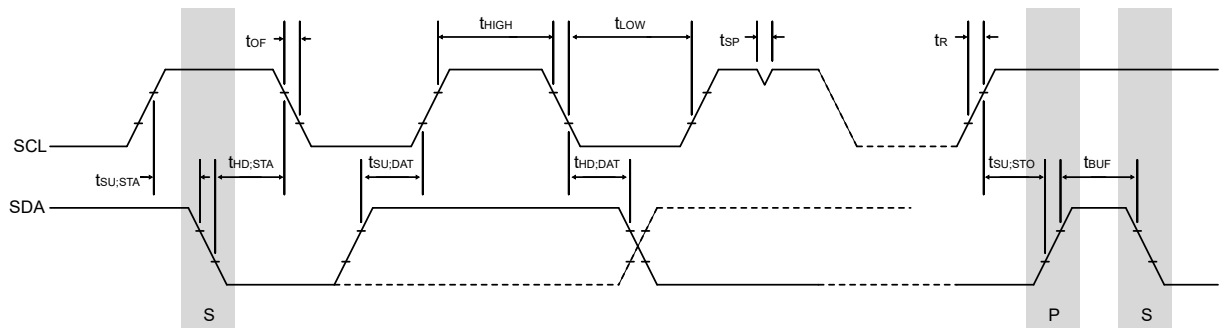

- t_{LOW} is the low period of SCL clock
- t_{HIGH} is the high period of SCL clock
- t_R is determined by the bus impedance; for internal pull-ups. Refer to the *Electrical Characteristics* section for details.
- t_{OF} is the output fall time and is determined by the open-drain current limit and bus impedance. Refer to the *Electrical Characteristics* section for details.

Properties of the SCL Clock

The SCL frequency is given by:

Equation 26-1. SCL Frequency

$$f_{SCL} = \frac{1}{t_{LOW} + t_{HIGH} + t_{OF} + t_R} [\text{Hz}]$$

The SCL clock is designed to have a 50/50 duty cycle, where the low period of the duty cycle comprises of t_{OF} and t_{LOW} . t_{HIGH} will not start until a high state of SCL has been detected. The BAUD bit field in the TWIn.MBAUD register and the SCL frequency are related by the following formula:

Equation 26-2. SCL Frequency

$$f_{SCL} = \frac{f_{CLK_PER}}{10 + 2 \times BAUD + f_{CLK_PER} \times t_R}$$

Equation 26-2 can be transformed to express BAUD:

Equation 26-3. BAUD

$$BAUD = \frac{f_{CLK_PER}}{2 \times f_{SCL}} - \left(5 + \frac{f_{CLK_PER} \times t_R}{2} \right)$$

Calculation of the BAUD Value

To ensure operation within the specifications of the desired speed mode (Sm, Fm, Fm+), follow these steps:

1. Calculate a value for the BAUD bit field using [Equation 26-3](#).
2. Calculate t_{LOW} using the BAUD value from step 1:

Equation 26-4. t_{LOW}

$$t_{LOW} = \frac{BAUD + 5}{f_{CLK_PER}} - t_{OF}$$

3. Check if t_{LOW} from [Equation 26-4](#) is above the specified minimum of the desired mode ($t_{LOW_Sm} = 4700$ ns, $t_{LOW_Fm} = 1300$ ns, $t_{LOW_Fm+} = 500$ ns).
 - If the calculated t_{LOW} is above the limit, use the BAUD value from [Equation 26-3](#)
 - If the limit is not met, calculate a new BAUD value using [Equation 26-5](#) below, where t_{LOW_mode} is either t_{LOW_Sm} , t_{LOW_Fm} , or t_{LOW_Fm+} from the mode specifications:

Equation 26-5. BAUD

$$BAUD = f_{CLK_PER} \times (t_{LOW_mode} + t_{OF}) - 5$$

26.3.2.2.2 TWI Bus State Logic

The bus state logic continuously monitors the activity on the TWI bus when the host is enabled. It continues to operate in all sleep modes, including Power-Down.

The bus state logic includes Start and Stop condition detectors, collision detection, inactive bus time-out detection, and a bit counter. These are used to determine the bus state. The software can get the current bus state by reading the Bus State (BUSSTATE) bit field in the Host Status (TWIn.MSTATUS) register.

The bus state can be Unknown, Idle, Busy or Owner, and it is determined according to the state diagram shown below.

Figure 26-4. Bus State Diagram

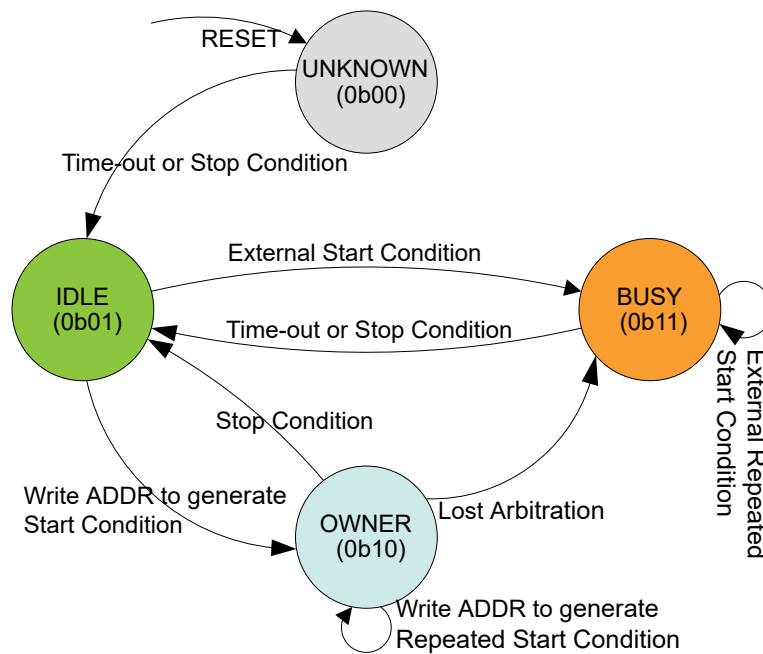

1. **Unknown:** The bus state machine is active when the TWI host is enabled. After the TWI host has been enabled, the bus state is Unknown. The bus state will also be set to Unknown after a system Reset is performed or after the TWI host is disabled.
2. **Idle:** The bus state machine can be forced to enter the Idle state by writing 0x1 to the Bus State (BUSSTATE) bit field. The bus state logic cannot be forced into any other state. If no state is set by the application software, the bus state will become Idle when the first Stop condition is detected. If the Inactive Bus Time-Out (TIMEOUT) bit field from the Host Control A (TWIn.MCTRLA) register is configured to a nonzero value, the bus state will change to Idle on the occurrence of a time-out. When the bus is Idle, it is ready for a new transaction.
3. **Busy:** If a Start condition, generated externally, is detected when the bus is Idle, the bus state becomes Busy. The bus state changes back to Idle when a Stop condition is detected or when a time-out, if configured, is set.
4. **Owner:** If a Start condition is generated internally when the bus is Idle, the bus state becomes Owner. If the complete transaction is performed without interference, the host issues a Stop condition, and the bus state changes back to Idle. If a collision is detected, the arbitration is lost, and the bus state becomes Busy until a Stop condition is detected.

26.3.2.2.3 Transmitting Address Packets

The host starts performing a bus transaction when the Host Address (TWIn.MADDR) register is written with the client address and the R/W direction bit. The value of the MADDR register is then copied into the Host Data (TWIn.MDATA) register. If the bus state is Busy, the TWI host will wait until the bus state becomes Idle before issuing the Start condition. The TWI will issue a Start condition, and the shift register performs a byte transmit operation on the bus.

Depending on the arbitration and the R/W direction bit, one of four cases (M1 to M4) arises after the transmission of the address packet.

Figure 26-5. TWI Host Operation

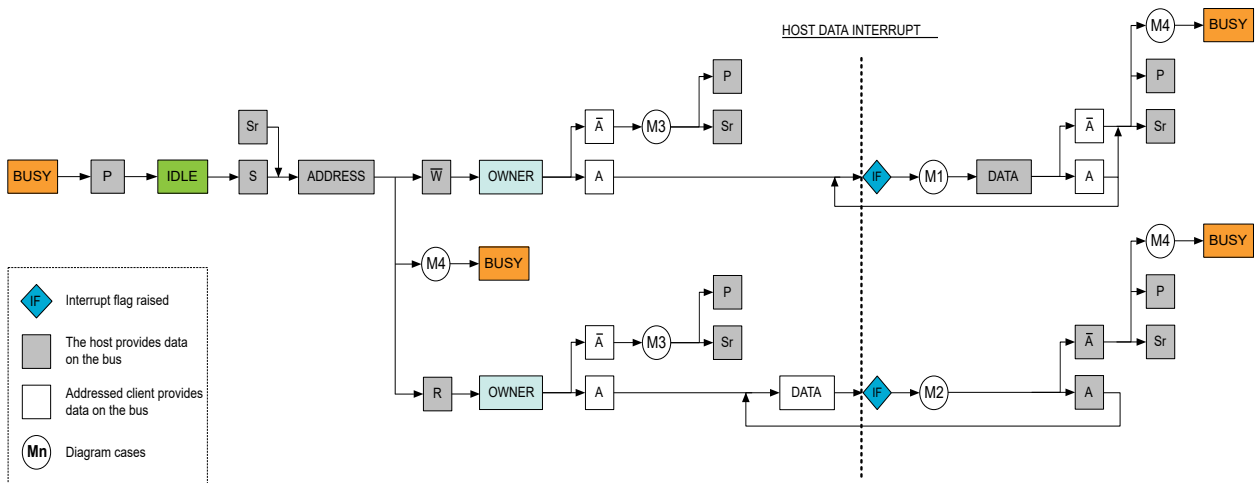

Case M1: Address Packet Transmit Complete - Direction Bit Set to '0'

If a client device responds to the address packet with an ACK, the Write Interrupt Flag (WIF) is set to '1', the Received Acknowledge (RXACK) flag is set to '0', and the Clock Hold (CLKHOLD) flag is set to '1'. The WIF, RXACK and CLKHOLD flags are located in the Host Status (TWIn.MSTATUS) register.

The clock hold is active at this point, forcing the SCL low. This will stretch the low period of the clock to slow down the overall clock frequency, forcing delays required to process the data and preventing further activity on the bus.

The software can prepare to:

- Transmit data packets to the client

Case M2: Address Packet Transmit Complete - Direction Bit Set to '1'

If a client device responds to the address packet with an ACK, the RXACK flag is set to '0', and the client can start sending data to the host without any delays because the client owns the bus at this moment. The clock hold is active at this point, forcing the SCL low.

The software can prepare to:

- Read the received data packet from the client

Case M3: Address Packet Transmit Complete - Address not Acknowledged by Client

If no client device responds to the address packet, the WIF and the RXACK flags will be set to '1'. The clock hold is active at this point, forcing the SCL low.

The missing ACK response can indicate that the I²C client is busy with other tasks, or it is in a sleep mode, and it is not able to respond.

The software can prepare to take one of the following actions:

- Retransmit the address packet
- Complete the transaction by issuing a Stop condition in the Command (MCMD) bit field from the Host Control B (TWIn.MCTRLB) register, which is the recommended action

Case M4: Arbitration Lost or Bus Error

If the arbitration is lost, both the WIF and the Arbitration Lost (ARBLOST) flags in the Host Status (TWIn.MSTATUS) register are set to '1'. The SDA is disabled, and the SCL is released. The bus state changes to Busy, and the host is no longer allowed to perform any operation on the bus until the bus state is changed back to Idle.

A bus error will behave similarly to the arbitration lost condition. In this case, the Bus Error (BUSERR) flag in the Host Status (TWIn.MSTATUS) register is set to '1', in addition to the WIF and ARBLOST flags.

The software can prepare to:

- Abort the operation and wait until the bus state changes to Idle by reading the Bus State (BUSSTATE) bit field in the Host Status (TWIn.MSTATUS) register

26.3.2.2.4 Transmitting Data Packets

Assuming the above M1 case, the TWI host can start transmitting data by writing to the Host Data (TWIn.MDATA) register, which will also clear the Write Interrupt Flag (WIF). During the data transfer, the host is continuously monitoring the bus for collisions and errors. The WIF flag will be set to '1' after the data packet transfer has been completed.

If the transmission is successful and the host receives an ACK bit from the client, the Received Acknowledge (RXACK) flag will be set to '0', meaning that the client is ready to receive new data packets.

The software can prepare to take one of the following actions:

- Transmit a new data packet
- Transmit a new address packet
- Complete the transaction by issuing a Stop condition in the Command (MCMD) bit field from the Host Control B (TWIn.MCTRLB) register

If the transmission is successful and the host receives a NACK bit from the client, the RXACK flag will be set to '1', meaning that the client is not able to or does not need to receive more data.

The software can prepare to take one of the following actions:

- Transmit a new address packet
- Complete the transaction by issuing a Stop condition in the Command (MCMD) bit field from the Host Control B (TWIn.MCTRLB) register

The RXACK status is valid only if the WIF flag is set to '1' and the Arbitration Lost (ARBLOST) and Bus Error (BUSERR) flags are set to '0'.

The transmission can be unsuccessful if a collision is detected. Then, the host will lose the arbitration, the Arbitration Lost (ARBLOST) flag will be set to '1', and the bus state changes to Busy. An arbitration lost during the sending of the data packet is treated the same way as the above M4 case.

The WIF, ARBLOST, BUSERR and RXACK flags are all located in the Host Status (TWIn.MSTATUS) register.

26.3.2.2.5 Receiving Data Packets

Assuming the M2 case above, the clock is released for one byte, allowing the client to put one byte of data on the bus. The host will receive one byte of data from the client, and the Read Interrupt Flag (RIF) will be set to '1' together with the Clock Hold (CLKHOLD) flag. The action selected by the Acknowledge Action (ACKACT) bit in the Host Control B (TWIn.MCTRLB) register is automatically sent on the bus when a command is written to the Command (MCMD) bit field in the TWIn.MCTRLB register.

The software can prepare to take one of the following actions:

- Respond with an ACK by writing '0' to the ACKACT bit in the TWIn.MCTRLB register and prepare to receive a new data packet
- Respond with a NACK by writing '1' to the ACKACT bit and then transmit a new address packet
- Respond with a NACK by writing '1' to the ACKACT bit and then complete the transaction by issuing a Stop condition in the MCMD bit field from the TWIn.MCTRLB register

A NACK response might not be successfully executed, as the arbitration can be lost during the transmission. If a collision is detected, the host loses the arbitration, the Arbitration Lost (ARBLOST) flag is set to '1', and the bus state changes to Busy. The Host Write Interrupt Flag (WIF) is set if the arbitration was lost when sending a NACK or a bus error occurred during the procedure. An arbitration lost during the sending of the data packet is treated in the same way as the above M4 case.

The RIF, CLKHOLD, ARBLOST and WIF flags are all located in the Host Status (TWIn.MSTATUS) register.

Note: The RIF and WIF flags are mutually exclusive and cannot be set simultaneously.

26.3.2.3 TWI Client Operation

The TWI client is byte-oriented with optional interrupts after each byte. There are separate interrupt flags for the client data and address/Stop recognition. Interrupt flags can also be used for polled operation. There are dedicated status flags for indicating ACK/NACK received, clock hold, collision, bus error, and R/W direction bit.

When an interrupt flag is set to '1', the SCL is forced low. This will give the client time to respond or handle any data and will, in most cases, require software interaction. The number of interrupts generated is kept to a minimum by automatic handling of most conditions.

The Permissive Mode Enable (PMEN) bit in the Client Control A (TWIn.SCTRLA) register can be configured to allow the client to respond to all received addresses.

26.3.2.3.1 Receiving Address Packets

When the TWI is configured as a client, it will wait for a Start condition to be detected. When this happens, the successive address packet will be received and checked by the address match logic. The client will ACK a correct address and store the address in the Client Data (TWIn.SDATA) register. If the received address is not a match, the client will not acknowledge or store the address but wait for a new Start condition.

The Address or Stop Interrupt Flag (APIF) in the Client Status (TWIn.SSTATUS) register is set to '1' when a Start condition is succeeded by one of the following:

- A valid address match with the address stored in the Address (ADDR[7:1]) bit field in the Client Address (TWIn.SADDR) register
- The General Call Address 0x00 and the Address (ADDR[0]) bit in the Client Address (TWIn.SADDR) register are set to '1'
- A valid address match with the secondary address stored in the Address Mask (ADDRMASK) bit field and the Address Mask Enable (ADDREN) bit is set to '1' in the Client Address Mask (TWIn.SADDRMASK) register
- Any address if the Permissive Mode Enable (PMEN) bit in the Client Control A (TWIn.SCTRLA) register is set to '1'

Depending on the Read/Write Direction (DIR) bit in the Client Status (TWIn.SSTATUS) register and the bus condition, one of four distinct cases (S1 to S4) arises after the reception of the address packet.

Figure 26-6. TWI Client Operation

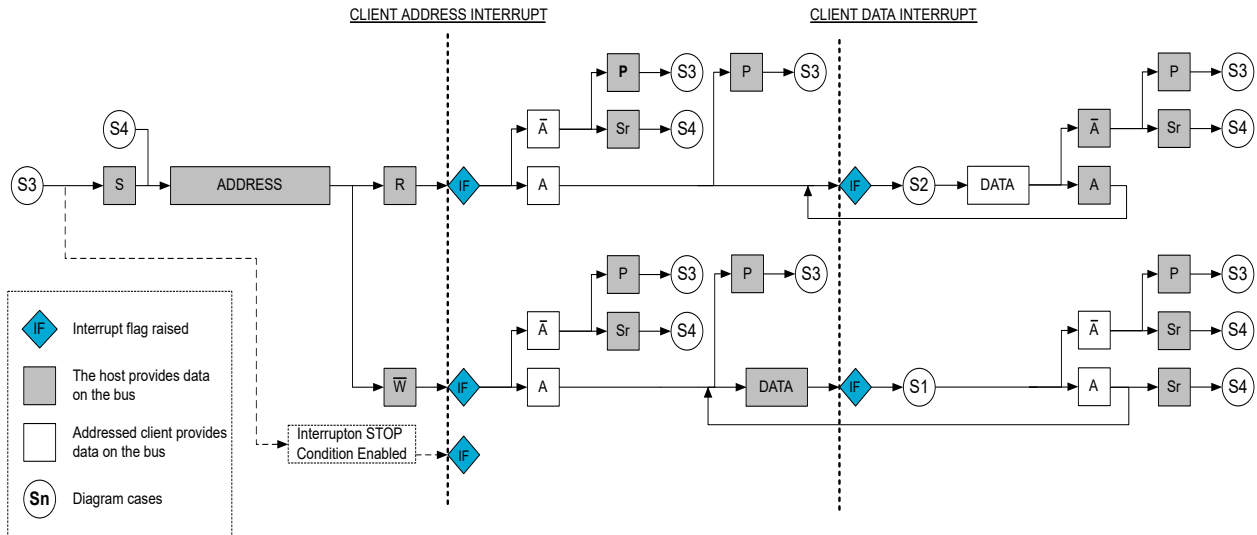

Case S1: Address Packet Accepted - Direction Bit Set to '0'

If an ACK is sent by the client after the address packet is received, and the Read/Write Direction (DIR) bit in the Client Status (TWIn.SSTATUS) register is set to '0', the host indicates a write operation.

The clock hold is active at this point, forcing the SCL low. This will stretch the low period of the clock to slow down the overall clock frequency, forcing delays required to process the data and preventing further activity on the bus.

The software can prepare to:

- Read the received data packet from the host

Case S2: Address Packet Accepted - Direction Bit Set to '1'

If an ACK is sent by the client after the address packet is received, and the DIR bit is set to '1', the host indicates a read operation, and the Data Interrupt Flag (DIF) in the Client Status (TWIn.SSTATUS) register will be set to '1'.

The clock hold is active at this point, forcing the SCL low.

The software can prepare to:

- Transmit data packets to the host

Case S3: Stop Condition Received

When the Stop condition is received, the Address or Stop (AP) flag will be set to '0', indicating that a Stop condition, and not an address match, activated the Address or Stop Interrupt Flag (APIF).

The AP and APIF flags are located in the Client Status (TWIn.SSTATUS) register.

The software can prepare to:

- Wait until a new address packet has been addressed to it

Case S4: Collision

If the client is not able to send a high-level data bit or a NACK, the Collision (COLL) bit in the Client Status (TWIn.SSTATUS) register is set to '1'. The client will commence its operation as normal, except no low values will be shifted out on the SDA. The data and acknowledge output from the client logic will be disabled. The clock hold is released. A Start or repeated Start condition will be accepted.

The COLL bit is intended for systems where the Address Resolution Protocol (ARP) is employed. A detected collision in non-ARP situations indicates that there has been a protocol violation and must be treated as a bus error.

26.3.2.3.2 Receiving Data Packets

Assuming the above S1 case, the client must be ready to receive data. When a data packet is received, the Data Interrupt Flag (DIF) in the Client Status (TWIn.SSTATUS) register is set to '1'. The action selected by the Acknowledge Action (ACKACT) bit in the Client Control B (TWIn.SCTRLB) register is automatically sent on the bus when a command is written to the Command (SCMD) bit field in the TWIn.SCTRLB register.

The software can prepare to take one of the following actions:

- Respond with an ACK by writing '0' to the ACKACT bit in the TWIn.SCTRLB register, indicating that the client is ready to receive more data
- Respond with a NACK by writing '1' to the ACKACT bit, indicating that the client cannot receive any more data and the host must issue a Stop or repeated Start condition

26.3.2.3.3 Transmitting Data Packets

Assuming the above S2 case, the client can start transmitting data by writing to the Client Data (TWIn.SDATA) register. When a data packet transmission is completed, the Data Interrupt Flag (DIF) in the Client Status (TWIn.SSTATUS) register is set to '1'.

The software can prepare to take one of the following actions:

- Check if the host responded with an ACK by reading the Received Acknowledge (RXACK) bit from the Client Status (TWIn.SSTATUS) register, and start transmitting new data packets
- Check if the host responded with a NACK by reading the RXACK bit, and stop transmitting data packets. The host must send a Stop or repeated Start condition after the NACK.

26.3.3 Additional Features

26.3.3.1 SMBus

If the TWI is used in an SMBus environment, the Inactive Bus Time-Out (TIMEOUT) bit field from the Host Control A (TWIn.MCTRLA) register must be configured. It is recommended to write to the Host Baud Rate (TWIn.MBAUD) register before setting the time-out because it is dependent on the baud rate setting.

A frequency of 100 kHz can be used for the SMBus environment. For the Standard mode (Sm) and Fast mode (Fm), the operating frequency has slew rate limited output, while for the Fast mode Plus (Fm+), it has x10 output drive strength.

The TWI also allows for an SMBus compatible SDA hold time configured in the SDA Hold Time (SDAHOLD) bit field from the Control A (TWIn.CTRLA) register.

26.3.3.2 Multi-Host

A host can start a bus transaction only if it has detected that the bus is in the Idle state. As the TWI bus is a multi-host bus, more devices may try to initiate a transaction at the same time. This results in multiple hosts owning the bus simultaneously. The TWI solves this problem by using an arbitration scheme where the host loses control of the bus if it is not able to transmit a high-level data bit on the SDA and the Bus State (BUSSTATE) bit field from the Host Status (TWIn.MSTATUS) register will be changed to Busy. The hosts that lose the arbitration must wait until the bus becomes Idle before attempting to reacquire the bus ownership.

Both devices can issue a Start condition, but DEVICE1 loses arbitration when attempting to transmit a high-level (bit 5) while DEVICE2 is transmitting a low-level.

Figure 26-7. TWI Arbitration

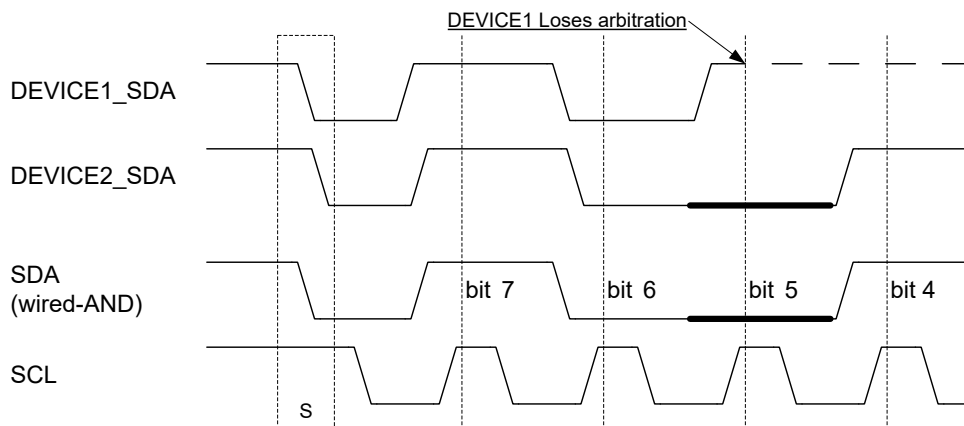

26.3.3.3 Smart Mode

The TWI interface has a Smart mode that simplifies the application code and minimizes the user interaction needed to adhere to the I²C protocol.

For the TWI host, the Smart mode will automatically send the ACK action as soon as the Host Data (TWIn.MDATA) register is read. This feature is only active when the Acknowledge Action (ACKACT) bit in the Host Control B (TWIn.MCTRLB) register is set to ACK. If the ACKACT bit is set to NACK, the TWI host will not generate a NACK after the MDATA register is read. This feature is enabled when the Smart Mode Enable (SMEN) bit in the Host Control A (TWIn.MCTRLA) register is set to '1'.

For the TWI client, the Smart mode will automatically send the ACK action as soon as the Client Data (TWIn.SDATA) register is read. The Smart mode will automatically set the Data Interrupt Flag (DIF) to '0' in the Client Status (TWIn.SSTATUS) register if the TWIn.SDATA register is read or written. This feature is enabled when the Smart Mode Enable (SMEN) bit in the Client Control A (TWIn.SCTRLA) register is set to '1'.

26.3.3.4 Quick Command Mode

With Quick Command mode, the R/W bit from the address packet denotes the command. This mode is enabled by writing '1' to the Quick Command Enable (QCEN) bit in the Host Control A (TWIn.MCTRLA) register. There are no data sent or received.

The Quick Command mode is SMBus specific, where the R/W bit can be used to turn a device function on/off or to enable/disable a low-power Standby mode. This mode can be enabled to auto-trigger operations and reduce software complexity.

After the host receives an ACK from the client, either the Read Interrupt Flag (RIF) or Write Interrupt Flag (WIF) will be set, depending on the value of the R/W bit. When either the RIF or WIF flag is set after issuing a Quick Command, the TWI will accept a Stop command by writing the Command (MCMD) bit field in the Host Control B (TWIn.MCTRLB) register.

The RIF and WIF flags, together with the value of the last Received Acknowledge (RXACK) flag, are all located in the Host Status (TWIn.MSTATUS) register.

Figure 26-8. Quick Command Frame Format

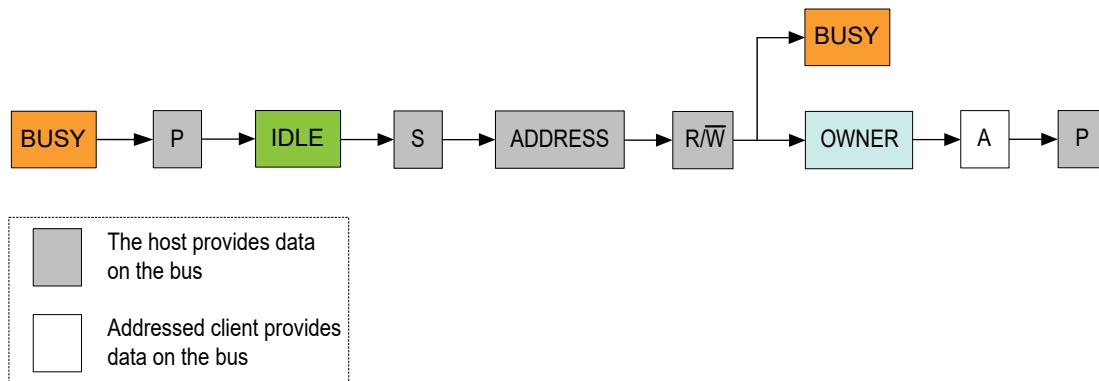

26.3.3.5 10-Bit Address

Regardless of whether the transaction is a read or write, the host must start by sending the 10-bit address with the R/W direction bit set to '0'.

The client address match logic supports recognition of 7-bit addresses and General Call Address. The Client Address (TWIn.SADDR) register is used by the client address match logic to determine if a host device has addressed the TWI client.

The TWI client address match logic only supports recognition of the first byte of a 10-bit address, and the second byte must be handled in software. The first byte of the 10-bit address will be recognized if the upper five bits of the Client Address (TWIn.SADDR) register are 0b11110. Thus, the first byte will consist of five indication bits, the two Most Significant bits (MSBs) of the 10-bits address, and the R/W direction bit. The Least Significant Byte (LSB) of the address that follows from the host will come in the form of a data packet.

Figure 26-9. 10-Bit Address Transmission

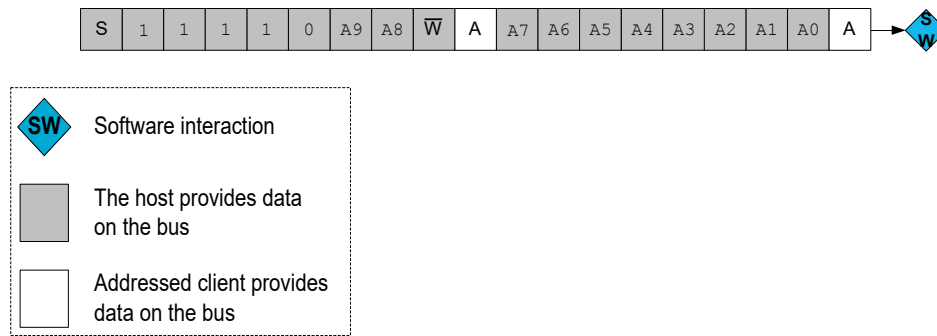

26.3.4 Interrupts

Table 26-1. Available Interrupt Vectors and Sources

Name	Vector Description	Conditions
Client	TWI Client interrupt	<ul style="list-style-type: none"> DIF: Data Interrupt Flag in TWIn.SSTATUS is set to '1' APIF: Address or Stop Interrupt Flag in TWIn.SSTATUS is set to '1'
Host	TWI Host interrupt	<ul style="list-style-type: none"> RIF: Read Interrupt Flag in TWIn.MSTATUS is set to '1' WIF: Write Interrupt Flag in TWIn.MSTATUS is set to '1'

When an interrupt condition occurs, the corresponding interrupt flag is set in the Host Status (TWIn.MSTATUS) register or the Client Status (TWIn.SSTATUS) register.

When several interrupt request conditions are supported by an interrupt vector, the interrupt requests are ORed together into one combined interrupt request to the interrupt controller. The user must read the interrupt flags from the TWIn.MSTATUS register or the TWIn.SSTATUS register to determine which of the interrupt conditions are present.

26.3.5 Sleep Mode Operation

The bus state logic and the address recognition hardware continue to operate in all sleep modes. If a client device is in a sleep mode and a Start condition followed by the address of the client is detected, clock stretching is active during the wake-up period until the main clock is available. The host will stop operation in all sleep modes.

26.3.6 Debug Operation

During run-time debugging, the TWI will continue normal operation. Halting the CPU in Debugging mode will halt the normal operation of the TWI. The TWI can be forced to operate with a halted CPU by writing a '1' to the Debug Run (DBGRUN) bit in the Debug Control (TWIn.DBGCTRL) register. When the CPU is halted in Debug mode, and the DBGRUN bit is '1', reading or writing the Host Data (TWIn.MDATA) register or the Client Data (TWIn.SDATA) register will neither trigger a bus operation nor cause transmit and clear flags. If the TWI is configured to require periodical service by the CPU through interrupts or similar, improper operation or data loss may result during halted debugging.

26.4 Register Summary

Offset	Name	Bit Pos.	7	6	5	4	3	2	1	0	
0x00	CTRLA	7:0				SDASETUP	SDAHOLD[1:0]		FMPEN		
0x01	Reserved										
0x02	DBGCTRL	7:0								DBGRUN	
0x03	MCTRLA	7:0	RIEN	WIEN		QCEN	TIMEOUT[1:0]		SMEN	ENABLE	
0x04	MCTRLB	7:0					FLUSH	ACKACT	MCMD[1:0]		
0x05	MSTATUS	7:0	RIF	WIF	CLKHOLD	RXACK	ARBLOST	BUSERR	BUSSTATE[1:0]		
0x06	MBAUD	7:0	BAUD[7:0]								
0x07	MADDR	7:0	ADDR[7:0]								
0x08	MDATA	7:0	DATA[7:0]								
0x09	SCTRLA	7:0	DIEN	APIEN	PIEN			PMEN	SMEN	ENABLE	
0x0A	SCTRLB	7:0						ACKACT	SCMD[1:0]		
0x0B	SSTATUS	7:0	DIF	APIF	CLKHOLD	RXACK	COLL	BUSERR	DIR	AP	
0x0C	SADDR	7:0	ADDR[7:0]								
0x0D	SDATA	7:0	DATA[7:0]								
0x0E	SADDRMASK	7:0	ADDRMASK[6:0]								ADDREN

26.5 Register Description

26.5.1 Control A

Name: CTRLA
Offset: 0x00
Reset: 0x00
Property: -

Bit	7	6	5	4	3	2	1	0
				SDASETUP	SDAHOLD[1:0]		FMPEN	
Access				R/W	R/W	R/W	R/W	
Reset				0	0	0	0	

Bit 4 – SDASETUP SDA Setup Time

This bit controls the number of cycles the SCL is stretched to ensure sufficient setup time on the SDA out signal. This bit is used when operating in client mode.

Value	Name	Description
0	4CYC	SDA setup time is four clock cycles
1	8CYC	SDA setup time is eight clock cycles

Bits 3:2 – SDAHOLD[1:0] SDA Hold Time

Writing this bit field selects the SDA hold time for the TWI. See the *Electrical Characteristics* section for details.

Value	Name	Description
0x0	OFF	Hold time OFF
0x1	50NS	Short hold time
0x2	300NS	Meets the SMBus 2.0 specifications under typical conditions
0x3	500NS	Meets the SMBus 2.0 specifications across all corners

Bit 1 – FMPEN FM Plus Enable

Writing a '1' to this bit selects the 1 MHz bus speed (Fast mode plus, Fm+) for the TWI in default configuration.

Value	Description
0	Operating in Standard mode or Fast mode
1	Operating in Fast mode plus

26.5.2 Debug Control

Name: DBGCTRL
Offset: 0x02
Reset: 0x00
Property: -

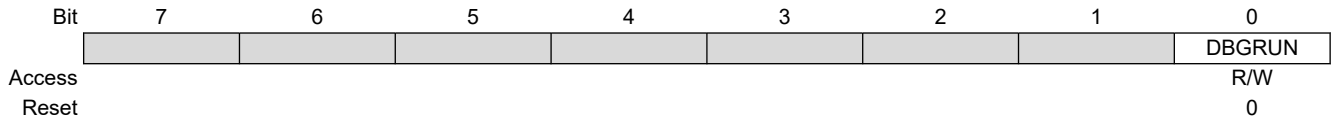

Bit 0 – DBGRUN Debug Run

Refer to the *Debug Operation* section for details.

Value	Description
0	The TWI is halted in Break Debug mode and ignores events
1	The TWI will continue to run in Break Debug mode when the CPU is halted

26.5.3 Host Control A

Name: MCTRLA
Offset: 0x03
Reset: 0x00
Property: -

Bit	7	6	5	4	3	2	1	0
	RIEN	WIEN		QCEN	TIMEOUT[1:0]		SMEN	ENABLE
Access	R/W	R/W		R/W	R/W	R/W	R/W	R/W
Reset	0	0		0	0	0	0	0

Bit 7 – RIEN Read Interrupt Enable

A TWI host read interrupt will be generated only if this bit and the Global Interrupt Enable (I) bit in the Status (CPU.SREG) register are set to '1'.

Writing a '1' to this bit enables the interrupt on the Read Interrupt Flag (RIF) in the Host Status (TWIn.MSTATUS) register. When the host read interrupt occurs, the RIF flag is set to '1'.

Bit 6 – WIEN Write Interrupt Enable

A TWI host write interrupt will be generated only if this bit and the Global Interrupt Enable (I) bit in the Status (CPU.SREG) register are set to '1'.

Writing a '1' to this bit enables the interrupt on the Write Interrupt Flag (WIF) in the Host Status (TWIn.MSTATUS) register. When the host write interrupt occurs, the WIF flag is set to '1'.

Bit 4 – QCEN Quick Command Enable

Writing a '1' to this bit enables the Quick Command mode. If the Quick Command mode is enabled and a client acknowledges the address, the corresponding Read Interrupt Flag (RIF) or Write Interrupt Flag (WIF) will be set depending on the value of the R/W bit.

The software must issue a Stop command by writing to the Command (MCMD) bit field in the Host Control B (TWIn.MCTRLB) register.

Bits 3:2 – TIMEOUT[1:0] Inactive Bus Time-Out

Setting this bit field to a nonzero value will enable the inactive bus time-out supervisor. If the bus is inactive for longer than the TIMEOUT setting, the bus state logic will enter the Idle state.

Value	Name	Description
0x0	DISABLED	Bus time-out disabled - I ² C
0x1	50US	50 μs - SMBus
0x2	100US	100 μs
0x3	200US	200 μs

Bit 1 – SMEN Smart Mode Enable

Writing a '1' to this bit enables the Host Smart mode. When the Smart mode is enabled, the existing value in the Acknowledge Action (ACKACT) bit from the Host Control B (TWIn.MCTRLB) register is sent immediately after reading the Host Data (TWIn.MDATA) register.

Bit 0 – ENABLE Enable TWI Host

Writing a '1' to this bit enables the TWI as host.

26.5.4 Host Control B

Name: MCTRLB
Offset: 0x04
Reset: 0x00
Property: -

Bit	7	6	5	4	3	2	1	0
Access					FLUSH	ACKACT	MCMD[1:0]	
Reset					R/W	R/W	R/W	R/W
					0	0	0	0

Bit 3 – FLUSH Flush

This bit clears the internal state of the host and the bus states changes to Idle. The TWI will transmit invalid data if the Host Data (TWIn.MDATA) register is written before the Host Address (TWIn.MADDR) register. Writing to Host Address (TWIn.MADDR) and Host Data (TWIn.MDATA) after a Flush will cause a transaction to start as soon as hardware detects SCL bus free.

Writing a '1' to this bit generates a strobe for one clock cycle, disabling the host and then re-enabling the host. Writing a '0' to this bit has no effect.

Bit 2 – ACKACT Acknowledge Action

The ACKACT⁽¹⁾ bit represents the behavior in the Host mode under certain conditions defined by the bus state and the software interaction. If the Smart Mode Enable (SMEN) bit in the Host Control A (TWIn.MCTRLA) register is set to '1', the acknowledge action is performed when the Host Data (TWIn.MDATA) register is read, else a command must be written to the Command (MCDM) bit field in the Host Control B (TWIn.MCTRLB) register.

The acknowledge action is not performed when the Host Data (TWIn.MDATA) register is written since the host is sending data.

Value	Name	Description
0	ACK	Send ACK
1	NACK	Send NACK

Bits 1:0 – MCMD[1:0] Command

The MCMD⁽¹⁾ bit field is a strobe. This bit field is always read as '0'.

Writing to this bit field triggers a host operation, as defined by the table below.

Table 26-2. Command Settings

MCMD[1:0]	Group Configuration	DIR	Description
0x0	NOACT	X	Reserved
0x1	REPSTART	X	Execute Acknowledge Action followed by repeated Start condition
0x2	RECVTRANS	\bar{W}	Execute Acknowledge Action (no action) followed by a byte write operation ⁽²⁾
		R	Execute Acknowledge Action followed by a byte read operation
0x3	STOP	X	Execute Acknowledge Action followed by issuing a Stop condition

Notes:

1. The ACKACT bit and the MCMD bit field can be written at the same time.
2. For a host write operation, the TWI will wait for new data to be written to the Host Data (TWIn.MDATA) register.

26.5.5 Host Status

Name: MSTATUS
Offset: 0x05
Reset: 0x00
Property: -

Bit	7	6	5	4	3	2	1	0
	RIF	WIF	CLKHOLD	RXACK	ARBLOST	BUSERR	BUSSTATE[1:0]	
Access	R/W	R/W	R/W	R	R/W	R/W	R/W	R/W
Reset	0	0	0	0	0	0	0	0

Bit 7 – RIF Read Interrupt Flag

This flag is set to '1' when the host byte read operation is completed.

The RIF flag can be used for a host read interrupt. More information can be found in the Read Interrupt Enable (RIEN) bit from the Host Control A (TWIn.MCTRLA) register.

This flag is automatically cleared when accessing several other TWI registers. The RIF flag can be cleared by choosing one of the following methods:

1. Writing a '1' to it.
2. Writing to the Host Address (TWIn.MADDR) register.
3. Writing/Reading the Host Data (TWIn.MDATA) register.
4. Writing to the Command (MCMD) bit field from the Host Control B (TWIn.MCTRLB) register.

Bit 6 – WIF Write Interrupt Flag

This flag is set to '1' when a host transmit address or byte write operation is completed, regardless of the occurrence of a bus error or arbitration lost condition.

The WIF flag can be used for a host write interrupt. More information can be found from the Write Interrupt Enable (WIEN) bit in the Host Control A (TWIn.MCTRLA) register.

This flag can be cleared by choosing one of the methods described for the RIF flag.

Bit 5 – CLKHOLD Clock Hold

When this bit is read as '1', it indicates that the host is currently holding the SCL low, stretching the TWI clock period.

This bit can be cleared by choosing one of the methods described for the RIF flag.

Bit 4 – RXACK Received Acknowledge

When this flag is read as '0', it indicates that the most recent Acknowledge bit from the client was ACK, and the client is ready for more data.

When this flag is read as '1', it indicates that the most recent Acknowledge bit from the client was NACK, and the client is not able to or does not need to receive more data.

Bit 3 – ARBLOST Arbitration Lost

When this bit is read as '1', it indicates that the host has lost arbitration. This can happen in one of the following cases:

1. While transmitting a high data bit.
2. While transmitting a NACK bit.
3. While issuing a Start condition (S).
4. While issuing a repeated Start (Sr).

This flag can be cleared by choosing one of the methods described for the RIF flag.

Bit 2 – BUSERR Bus Error

The BUSERR flag indicates that an illegal bus operation has occurred. An illegal bus operation is detected if a protocol violating the Start (S), repeated Start (Sr), or Stop (P) conditions is detected on the TWI bus lines. A Start condition directly followed by a Stop condition is one example of a protocol violation.

The BUSERR flag can be cleared by choosing one of the following methods:

1. Writing a '1' to it.
2. Writing to the Host Address (TWIn.MADDR) register.

The TWI bus error detector is part of the TWI host circuitry. For the bus errors to be detected, the TWI host must be enabled (ENABLE bit in TWIn.MCTRLA is '1'), and the main clock frequency must be at least four times the SCL frequency.

Bits 1:0 – BUSSTATE[1:0] Bus State

This bit field indicates the current TWI bus state. Writing 0x1 to this bit field will force the bus state to IDLE. All other values will be ignored.

Value	Name	Description
0x0	UNKNOWN	Unknown bus state
0x1	IDLE	Idle bus state
0x2	OWNER	This TWI controls the bus
0x3	BUSY	Busy bus state

26.5.6 Host Baud Rate

Name: MBAUD
Offset: 0x06
Reset: 0x00
Property: -

Bit	7	6	5	4	3	2	1	0
	BAUD[7:0]							
Access	R/W	R/W	R/W	R/W	R/W	R/W	R/W	R/W
Reset	0	0	0	0	0	0	0	0

Bits 7:0 – BAUD[7:0] Baud Rate

This bit field is used to derive the SCL high and low time. It must be written while the host is disabled. The host can be disabled by writing '0' to the Enable TWI Host (ENABLE) bit from the Host Control A (TWIn.MCTRLA) register. Refer to the *Clock Generation* section for more information on how to calculate the frequency of the SCL.

26.5.7 Host Address

Name: MADDR
Offset: 0x07
Reset: 0x00
Property: -

Bit	7	6	5	4	3	2	1	0
	ADDR[7:0]							
Access	R/W	R/W	R/W	R/W	R/W	R/W	R/W	R/W
Reset	0	0	0	0	0	0	0	0

Bits 7:0 – ADDR[7:0] Address

This register contains the address of the external client device. When this bit field is written, the TWI will issue a Start condition, and the shift register performs a byte transmit operation on the bus depending on the bus state.

This register can be read at any time without interfering with the ongoing bus activity since a read access does not trigger the host logic to perform any bus protocol related operations.

The host control logic uses the bit 0 of this register as the R/W direction bit.

26.5.8 Host Data

Name: MDATA
Offset: 0x08
Reset: 0x00
Property: -

Bit	7	6	5	4	3	2	1	0
	DATA[7:0]							
Access	R/W	R/W	R/W	R/W	R/W	R/W	R/W	R/W
Reset	0	0	0	0	0	0	0	0

Bits 7:0 – DATA[7:0] Data

This bit field provides direct access to the host's physical shift register, which is used to shift out data on the bus (transmit) and to shift in data received from the bus (receive). The direct access implies that the MDATA register cannot be accessed during byte transmissions.

Reading valid data or writing data to be transmitted can only be successful when the CLKHOLD bit is read as '1' or when an interrupt occurs.

A write access to the MDATA register will command the host to perform a byte transmit operation on the bus, directly followed by receiving the Acknowledge bit from the client. This is independent of the Acknowledge Action (ACKACT) bit from the Host Control B (TWIn.MCTRLB) register. The write operation is performed regardless of winning or losing arbitration before the Write Interrupt Flag (WIF) is set to '1'.

If the Smart Mode Enable (SMEN) bit in the Host Control A (TWIn.MCTRLA) register is set to '1', a read access to the MDATA register will command the host to perform an acknowledge action. This is dependent on the setting of the Acknowledge Action (ACKACT) bit from the Host Control B (TWIn.MCTRLB) register.

Notes:

1. The WIF and RIF flags are cleared automatically if the MDATA register is read while ACKACT is set to '1'.
2. The ARBLOST and BUSEER flags are left unchanged.
3. The WIF, RIF, ARBLOST, and BUSERR flags together with the Clock Hold (CLKHOLD) bit are all located in the Host Status (TWIn.MSTATUS) register.

26.5.9 Client Control A

Name: SCTRLA
Offset: 0x09
Reset: 0x00
Property: -

Bit	7	6	5	4	3	2	1	0
	DIEN	APIEN	PIEN			PMEN	SMEN	ENABLE
Access	R/W	R/W	R/W			R/W	R/W	R/W
Reset	0	0	0			0	0	0

Bit 7 – DIEN Data Interrupt Enable

Writing this bit to '1' enables an interrupt on the Data Interrupt Flag (DIF) from the Client Status (TWIn.SSTATUS) register.

A TWI client data interrupt will be generated only if this bit, the DIF flag, and the Global Interrupt Enable (I) bit in the Status (CPU.SREG) register are all '1'.

Bit 6 – APIEN Address or Stop Interrupt Enable

Writing this bit to '1' enables an interrupt on the Address or Stop Interrupt Flag (APIF) from the Client Status (TWIn.SSTATUS) register.

A TWI client address or stop interrupt will be generated only if this bit, the APIF flag, and the Global Interrupt Enable (I) bit in the Status (CPU.SREG) register are all '1'.

Notes:

1. The client stop interrupt shares the interrupt flag and vector with the client address interrupt.
2. The Stop Interrupt Enable (PIEN) bit in the Client Control A (TWIn.SCTRLA) register must be written to '1' for the APIF to be set on a Stop condition.
3. When the interrupt occurs, the Address or Stop (AP) bit in the Client Status (TWIn.SSTATUS) register will determine whether an address match or a Stop condition caused the interrupt.

Bit 5 – PIEN Stop Interrupt Enable

Writing this bit to '1' allows the Address or Stop Interrupt Flag (APIF) in the Client Status (TWIn.SSTATUS) register to be set when a Stop condition occurs. The main clock frequency must be at least four times the SCL frequency to use this feature.

Bit 2 – PMEN Permissive Mode Enable

If this bit is written to '1', the client address match logic responds to all received addresses.

If this bit is written to '0', the address match logic uses the Client Address (TWIn.SADDR) register to determine which address to recognize as the client's address.

Bit 1 – SMEN Smart Mode Enable

Writing this bit to '1' enables the client Smart mode. When the Smart mode is enabled, issuing a command by writing to the Command (SCMD) bit field in the Client Control B (TWIn.SCTRLB) register or accessing the Client Data (TWIn.SDATA) register resets the interrupt, and the operation continues. If the Smart mode is disabled, the client always waits for a new client command before continuing.

Bit 0 – ENABLE Enable TWI Client

Writing this bit to '1' enables the TWI client.

26.5.10 Client Control B

Name: SCTRLB
Offset: 0x0A
Reset: 0x00
Property: -

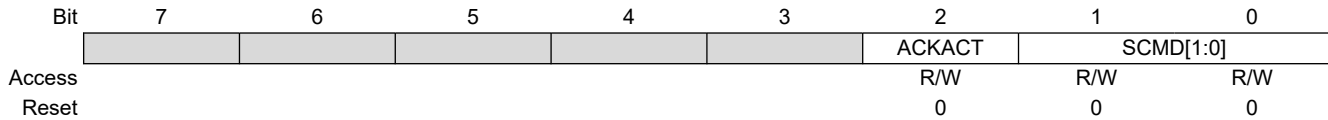

Bit 2 – ACKACT Acknowledge Action

The ACKACT⁽¹⁾ bit represents the behavior of the client device under certain conditions defined by the bus protocol state and the software interaction. If the Smart Mode Enable (SMEN) bit in the Client Control A (TWIn.SCTRLA) register is set to '1', the acknowledge action is performed when the Client Data (TWIn.SDATA) register is read, else a command must be written to the Command (SCMD) bit field in the Client Control B (TWIn.SCTRLB) register. The acknowledge action is not performed when the Client Data (TWIn.SDATA) register is written since the client is sending data.

Value	Name	Description
0	ACK	Send ACK
1	NACK	Send NACK

Bits 1:0 – SCMD[1:0] Command

The SCMD⁽¹⁾ bit field is a strobe. This bit field is always read as '0'.

Writing to this bit field triggers a client operation as defined by the table below.

Table 26-3. Command Settings

Value	Name	DIR	Description
0x0	NOACT	X	No action
0x1	—	X	Reserved
0x2	COMPTRANS	\bar{W}	Execute Acknowledge Action succeeded by waiting for any Start (S/Sr) condition
		R	Wait for any Start (S/Sr) condition
0x3	RESPONSE	\bar{W}	Execute Acknowledge Action succeeded by reception of next byte
		R	Used in response to an address interrupt (APIF): Execute Acknowledge Action succeeded by client data interrupt.
			Used in response to a data interrupt (DIF): Execute a byte read operation followed by Acknowledge Action.

Note: 1. The ACKACT bit and the SCMD bit field can be written at the same time. The ACKACT will be updated before the command is triggered.

26.5.11 Client Status

Name: SSTATUS
Offset: 0x0B
Reset: 0x00
Property: -

Bit	7	6	5	4	3	2	1	0
	DIF	APIF	CLKHOLD	RXACK	COLL	BUSERR	DIR	AP
Access	R/W	R/W	R	R	R/W	R/W	R	R
Reset	0	0	0	0	0	0	0	0

Bit 7 – DIF Data Interrupt Flag

This flag is set to '1' when the client byte transmit or receive operation is completed without any bus errors. This flag can be set to '1' with an unsuccessful transaction in case of collision detection. More information can be found in the Collision (COLL) bit description.

The DIF flag can generate a client data interrupt. More information can be found in Data Interrupt Enable (DIEN) bit from the Client Control A (TWIn.SCTRLA) register.

This flag is automatically cleared when accessing several other TWI registers. The DIF flag can be cleared by choosing one of the following methods:

1. Writing/Reading the Client Data (TWIn.SDATA) register.
2. Writing to the Command (SCMD) bit field from the Client Control B (TWIn.SCTRLB) register.

Bit 6 – APIF Address or Stop Interrupt Flag

This flag is set to '1' when the client address has been received or by a Stop condition.

The APIF flag can generate a client address or stop interrupt. More information can be found in the Address or Stop Interrupt Enable (APIEN) bit from the Client Control A (TWIn.SCTRLA) register.

This flag can be cleared by choosing one of the methods described for the DIF flag.

Bit 5 – CLKHOLD Clock Hold

When this bit is read as '1', it indicates that the client is currently holding the SCL low, stretching the TWI clock period.

This bit is set to '1' when an address or data interrupt occurs. Resetting the corresponding interrupt will indirectly set this bit to '0'.

Bit 4 – RXACK Received Acknowledge

When this flag is read as '0', it indicates that the most recent Acknowledge bit from the host was ACK.

When this flag is read as '1', it indicates that the most recent Acknowledge bit from the host was NACK.

Bit 3 – COLL Collision

When this bit is read as '1', it indicates that the client has not been able to do one of the following:

1. Transmit high bits on the SDA. The Data Interrupt Flag (DIF) will be set to '1' at the end as a result of the internal completion of an unsuccessful transaction.
2. Transmit the NACK bit. The collision occurs because the client address match already took place, and the APIF flag is set to '1' as a result.

Writing a '1' to this bit will clear the COLL flag. The flag is automatically cleared if any Start condition (S/Sr) is detected.

Note: The APIF and DIF flags can only generate interrupts whose handlers can be used to check for the collision.

Bit 2 – BUSERR Bus Error

The BUSERR flag indicates that an illegal bus operation has occurred. An illegal bus operation is detected if a protocol violating the Start (S), repeated Start (Sr), or Stop (P) conditions is detected on the TWI bus lines. A Start condition directly followed by a Stop condition is one example of a protocol violation.

Writing a '1' to this bit will clear the BUSERR flag.

The TWI bus error detector is part of the TWI Host circuitry. For the bus errors to be detected by the client, the TWI Host must be enabled, and the main clock frequency must be at least four times the SCL frequency. The TWI Host can be enabled by writing '1' to the ENABLE bit in the TWIn.MCTRLA register.

Bit 1 – DIR Read/Write Direction

This bit indicates the current TWI bus direction. The DIR bit reflects the direction bit value from the last address packet received from a host TWI device.

When this bit is read as '1', it indicates that a host read operation is in progress.

When this bit is read as '0', it indicates that a host write operation is in progress.

Bit 0 – AP Address or Stop

When the TWI client Address or Stop Interrupt Flag (APIF) is set '1', this bit determines whether the interrupt is due to an address detection or a Stop condition.

Value	Name	Description
0	STOP	A Stop condition generated the interrupt on the APIF flag
1	ADR	Address detection generated the interrupt on the APIF flag

26.5.12 Client Address

Name: SADDR
Offset: 0x0C
Reset: 0x00
Property: -

Bit	7	6	5	4	3	2	1	0
	ADDR[7:0]							
Access	R/W	R/W	R/W	R/W	R/W	R/W	R/W	R/W
Reset	0	0	0	0	0	0	0	0

Bits 7:0 – ADDR[7:0] Address

The Client Address (TWIn.SADDR) register is used by the client address match logic to determine if a host device has addressed the TWI client. The Address or Stop Interrupt Flag (APIF) and the Address or Stop (AP) bit in the Client Status (TWIn.SSTATUS) register are set to '1' if an address packet is received.

The upper seven bits (ADDR[7:1]) of the TWIn.SADDR register represent the main client address.

The Least Significant bit (ADDR[0]) of the TWIn.SADDR register is used for the recognition of the General Call Address (0x00) of the I²C protocol. This feature is enabled when this bit is set to '1'.

26.5.13 Client Data

Name: SDATA
Offset: 0x0D
Reset: 0x00
Property: -

Bit	7	6	5	4	3	2	1	0
	DATA[7:0]							
Access	R/W	R/W	R/W	R/W	R/W	R/W	R/W	R/W
Reset	0	0	0	0	0	0	0	0

Bits 7:0 – DATA[7:0] Data

This bit field provides access to the client data register.

Reading valid data or writing data to be transmitted can only be achieved when the SCL is held low by the client (i.e., when the client CLKHOLD bit is set to '1'). It is not necessary to check the Clock Hold (CLKHOLD) bit from the Client Status (TWIn.SSTATUS) register in software before accessing the SDATA register if the software keeps track of the present protocol state by using interrupts or observing the interrupt flags.

If the Smart Mode Enable (SMEN) bit in the Client Control A (TWIn.SCTRLA) register is set to '1', a read access to the SDATA register, when the clock hold is active, auto-triggers bus operations and will command the client to perform an acknowledge action. This is dependent on the setting of the Acknowledge Action (ACKACT) bit from the Client Control B (TWIn.SCTRLB) register.

26.5.14 Client Address Mask

Name: SADDRMASK
Offset: 0x0E
Reset: 0x00
Property: -

Bit	7	6	5	4	3	2	1	0
	ADDRMASK[6:0]							ADDREN
Access	R/W	R/W	R/W	R/W	R/W	R/W	R/W	R/W
Reset	0	0	0	0	0	0	0	0

Bits 7:1 – ADDRMASK[6:0] Address Mask

The ADDRMASK bit field acts as a second address match or an address mask register depending on the ADDREN bit.

If the ADDREN bit is written to '0', the ADDRMASK bit field can be loaded with a 7-bit Client Address mask. Each of the bits in the Client Address Mask (TWIn.SADDRMASK) register can mask (disable) the corresponding address bits in the TWI Client Address (TWIn.SADDR) register. When a bit from the mask is written to '1', the address match logic ignores the comparison between the incoming address bit and the corresponding bit in the Client Address (TWIn.SADDR) register. In other words, masked bits will always match, making it possible to recognize the ranges of addresses.

If the ADDREN bit is written to '1', the Client Address Mask (TWIn.SADDRMASK) register can be loaded with a second client address in addition to the Client Address (TWIn.SADDR) register. In this mode, the client will have two unique addresses, one in the Client Address (TWIn.SADDR) register and the other one in the Client Address Mask (TWIn.SADDRMASK) register.

Bit 0 – ADDREN Address Mask Enable

If this bit is written to '0', the TWIn.SADDRMASK register acts as a mask to the TWIn.SADDR register.

If this bit is written to '1', the client address match logic responds to the two unique addresses in the client TWIn.SADDR and TWIn.SADDRMASK registers.

27. CRCSCAN - Cyclic Redundancy Check Memory Scan

27.1 Features

- CRC-16-CCITT
- Check of the Entire Flash Section, Application Code, and/or Boot Section
- Selectable NMI Trigger on Failure
- User-Configurable Check During Internal Reset Initialization

27.2 Overview

A Cyclic Redundancy Check (CRC) takes a data stream of bytes from the NVM (either the entire Flash, only the Boot section, or both the Boot section and the application code section) and generates a checksum. The CRC peripheral (CRCSCAN) can be used to detect errors in the program memory.

The last location in the section to check has to contain the correct pre-calculated 16-bit checksum for comparison. If the checksum calculated by the CRCSCAN and the pre-calculated checksums match, a status bit is set. If they do not match, the Status register (CRCSCAN.STATUS) will indicate that it failed. The user can choose to let the CRCSCAN generate a Non-Maskable Interrupt (NMI) if the checksums do not match.

An n -bit CRC applied to a data block of arbitrary length will detect any single alteration (error burst) up to n bits in length. For longer error bursts a fraction $1-2^{-n}$ will be detected.

The CRC generator supports CRC-16-CCITT.

Polynomial:

- CRC-16-CCITT: $x^{16} + x^{12} + x^5 + 1$

The CRC reads byte-by-byte the content of the section(s) it is set up to check, starting with byte 0, and generates a new checksum per byte. The byte is sent through a shift register as depicted below, starting with the Most Significant bit. If the last bytes in the section contain the correct checksum, the CRC will pass. See [27.3.2.1. Checksum](#) for how to place the checksum. The initial value of the Checksum register is 0xFFFF.

Figure 27-1. CRC Implementation Description

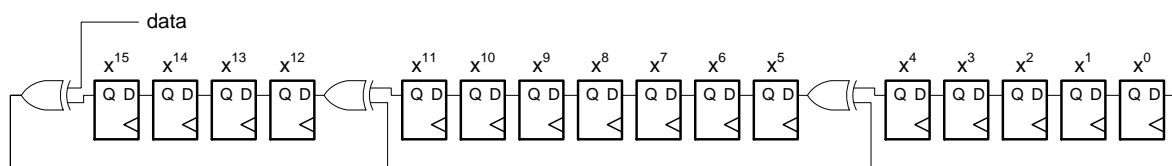

27.2.1 Block Diagram

Figure 27-2. Cyclic Redundancy Check Block Diagram

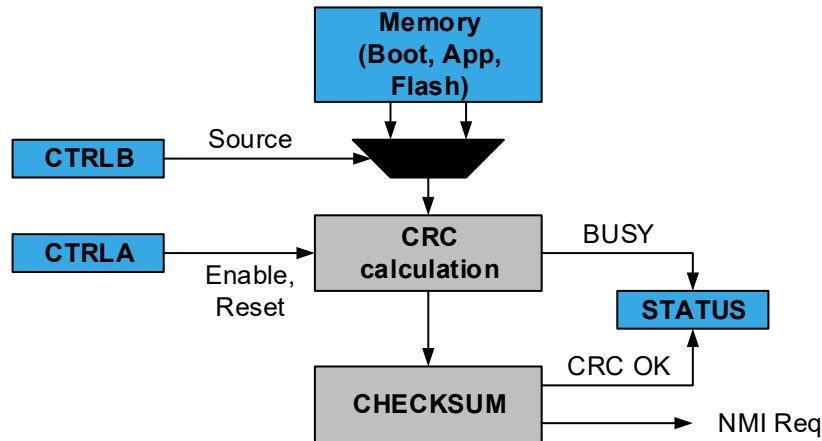

27.3 Functional Description

27.3.1 Initialization

To enable a CRC in software (or via the debugger):

1. Write the Source (SRC) bit field of the Control B register (CRCSCAN.CTRLB) to select the desired mode and source settings.
2. Enable the CRCSCAN by writing a '1' to the ENABLE bit in the Control A register (CRCSCAN.CTRLA).
3. The CRC will start after three cycles. The CPU will continue executing during these three cycles.

The CRCSCAN can be configured to perform a code memory scan before the device leaves Reset. If this check fails, the CPU is not allowed to start normal code execution. This feature is enabled and controlled by the CRCSRC field in FUSE.SYSCFG0, see the *Fuses* chapter for more information.

If this feature is enabled, a successful CRC check will have the following outcome:

- Normal code execution starts
- The ENABLE bit in CRCSCAN.CTRLA will be '1'
- The SRC bit field in CRCSCAN.CTRLB will reflect the checked section(s)
- The OK flag in CRCSCAN.STATUS will be '1'

If this feature is enabled, a non-successful CRC check will have the following outcome:

- Normal code execution does not start, the CPU will hang executing no code
- The ENABLE bit in CRCSCAN.CTRLA will be '1'
- The SRC bit field in CRCSCAN.CTRLB will reflect the checked section(s)
- The OK flag in CRCSCAN.STATUS will be '0'
- This condition may be observed using the debug interface

27.3.2 Operation

When the CRC is operating in Priority mode, the CRC peripheral has priority access to the Flash and will stall the CPU until completed.

In Priority mode the CRC fetches a new word (16-bit) on every third main clock cycle, or when the CRC peripheral is configured to do a scan from start-up.

27.3.2.1 Checksum

The pre-calculated checksum must be present in the last location of the section to be checked. If the BOOT section is to be checked, the checksum must be saved in the last bytes of the BOOT section, and similarly for APPLICATION and the entire Flash. [Table 27-1](#) shows explicitly how the checksum must be stored for the different sections. Also,

see the CRCSCAN.CTRLB register description for how to configure which section to check and the device fuse description for how to configure the BOOTEND and APPEND fuses.

Table 27-1. Placement of the Pre-Calculated Checksum in Flash

Section to Check	CHECKSUM[15:8]	CHECKSUM[7:0]
BOOT	FUSE_BOOTEND*256-2	FUSE_BOOTEND*256-1
BOOT and APPLICATION	FUSE_APPEND*256-2	FUSE_APPEND*256-1
Full Flash	FLASHEND-1	FLASHEND

27.3.3 Interrupts

Table 27-2. Available Interrupt Vectors and Sources

Name	Vector Description	Conditions
NMI	Non-Maskable Interrupt	CRC failure

When the interrupt condition occurs the OK flag in the Status (CRCSCAN.STATUS) register is cleared to '0'.

A Non-Maskable Interrupt (NMI) is enabled by writing a '1' to the respective Enable (NMIEN) bit in the Control A (CRCSCAN.CTRLA) register, but can only be disabled with a System Reset. An NMI is generated when the OK flag in the CRCSCAN.STATUS register is cleared, and the NMIEN bit is '1'. The NMI request remains active until a System Reset and cannot be disabled.

An NMI can be triggered even if interrupts are not globally enabled.

27.3.4 Sleep Mode Operation

CRCSCAN is halted in all Sleep modes. In all CPU Sleep modes, the CRCSCAN peripheral is halted and will resume operation when the CPU wakes up.

The CRCSCAN starts operation three cycles after writing the EN bit in CRCSCAN.CTRLA. During these three cycles, it is possible to enter Sleep mode. In this case:

1. The CRCSCAN will not start until the CPU is woken up.
2. Any interrupt handler will execute after CRCSCAN has finished.

27.3.5 Debug Operation

Whenever the debugger reads or writes a peripheral or memory location, the CRCSCAN will be disabled.

If the CRCSCAN is busy when the debugger accesses the device, the CRCSCAN will restart the ongoing operation when the debugger accesses an internal register or when the debugger disconnects.

The BUSY bit in the Status (CRCSCAN.STATUS) register will read '1' if the CRCSCAN was busy when the debugger caused it to disable, but it will not actively check any section as long as the debugger keeps it disabled. There are synchronized CRC status bits in the debugger's internal register space, which can be read by the debugger without disabling the CRCSCAN. Reading the debugger's internal CRC status bits will make sure that the CRCSCAN is enabled.

It is possible to write the CRCSCAN.STATUS register directly from the debugger:

- BUSY bit in CRCSCAN.STATUS:
 - Writing the BUSY bit to '0' will stop the ongoing CRC operation (so that the CRCSCAN does not restart its operation when the debugger allows it).
 - Writing the BUSY bit to '1' will make the CRC start a single check with the settings in the Control B (CRCSCAN.CTRLB) register, but not until the debugger allows it.

As long as the BUSY bit in CRCSCAN.STATUS is '1', CRCSCAN.CTRLB and the Non-Maskable Interrupt Enable (NMIEN) bit in the Control A (CRCSCAN.CTRLA) register cannot be altered.

- OK bit in CRCSCAN.STATUS:

- Writing the OK bit to '0' can trigger a Non-Maskable Interrupt (NMI) if the NMIEN bit in CRCSCAN.CTRLA is '1'. If an NMI has been triggered, no writes to the CRCSCAN are allowed.
- Writing the OK bit to '1' will make the OK bit read as '1' when the BUSY bit in CRCSCAN.STATUS is '0'.

Writes to CRCSCAN.CTRLA and CRCSCAN.CTRLB from the debugger are treated in the same way as writes from the CPU.

27.4 Register Summary

Offset	Name	Bit Pos.	7	6	5	4	3	2	1	0
0x00	CTRLA	7:0	RESET						NMIEN	ENABLE
0x01	CTRLB	7:0			MODE[1:0]				SRC[1:0]	
0x02	STATUS	7:0							OK	BUSY

27.5 Register Description

27.5.1 Control A

Name: CTRLA
Offset: 0x00
Reset: 0x00
Property: -

If an NMI has been triggered this register is not writable.

Bit	7	6	5	4	3	2	1	0
	RESET						NMIEN	ENABLE
Access	R/W						R/W	R/W
Reset	0						0	0

Bit 7 – RESET Reset CRCSCAN

Writing this bit to '1' resets the CRCSCAN peripheral. The CRCSCAN Control registers and Status register (CRCSCAN.CTRLA, CRCSCAN.CTRLB, CRCSCAN.STATUS) will be cleared one clock cycle after the RESET bit is written to '1'.

If NMIEN is '0', this bit is writable both when the CRCSCAN is busy (the BUSY bit in CRCSCAN.STATUS is '1') and not busy (the BUSY bit is '0'), and will take effect immediately.

If NMIEN is '1', this bit is only writable when the CRCSCAN is not busy (the BUSY bit in CRCSCAN.STATUS is '0'). The RESET bit is a strobe bit.

Bit 1 – NMIEN Enable NMI Trigger

When this bit is written to '1', any CRC failure will trigger an NMI.

This bit can only be cleared by a system Reset - it is not cleared by a write to the RESET bit.

This bit can only be written to '1' when the CRCSCAN is not busy (the BUSY bit in CRCSCAN.STATUS is '0').

Bit 0 – ENABLE Enable CRCSCAN

Writing this bit to '1' enables the CRCSCAN peripheral with the current settings. It will stay '1' even after a CRC check has completed, but writing it to '1' again will start a new check.

Writing the bit to '0' has no effect

The CRCSCAN can be configured to run a scan during the MCU start-up sequence to verify the Flash sections before letting the CPU start normal code execution (see the [27.3.1. Initialization](#) section). If this feature is enabled, the ENABLE bit will read as '1' when normal code execution starts.

To see whether the CRCSCAN peripheral is busy with an ongoing check, poll the BUSY bit in the Status register (CRCSCAN.STATUS).

27.5.2 Control B

Name: CTRLB
Offset: 0x01
Reset: 0x00
Property: -

The CRCSCAN.CTRLB register contains the mode and source settings for the CRC. It is not writable when the CRC is busy, or when an NMI has been triggered.

	7	6	5	4	3	2	1	0
			MODE[1:0]				SRC[1:0]	
Access			R/W	R/W			R/W	R/W
Reset			0	0			0	0

Bits 5:4 – MODE[1:0] CRC Flash Access Mode

The CRC can be enabled during internal Reset initialization to verify Flash sections before letting the CPU start (see the device data sheet fuse description). If the CRC is enabled during internal Reset initialization, the MODE bit field will read out non-zero when normal code execution starts. To ensure proper operation of the CRC under code execution, write the MODE bit to 0x0 again.

Value	Name	Description
0x0	PRIORITY	The CRC module runs a single check with priority to Flash. The CPU is halted until the CRC completes.
other	-	Reserved

Bits 1:0 – SRC[1:0] CRC Source

The SRC bit field selects which section of the Flash the CRC module will check. To set up section sizes, refer to the fuse description.

The CRC can be enabled during internal Reset initialization to verify Flash sections before letting the CPU start (see the *Fuses* chapter). If the CRC is enabled during internal Reset initialization, the SRC bit field will read out as FLASH, BOOTAPP, or BOOT when normal code execution starts (depending on the configuration).

Value	Name	Description
0x0	FLASH	The CRC is performed on the entire Flash (boot, application code, and application data sections).
0x1	BOOTAPP	The CRC is performed on the boot and application code sections of Flash.
0x2	BOOT	The CRC is performed on the boot section of Flash.
0x3	-	Reserved.

ATtiny3224/3226/3227

CRCSCAN - Cyclic Redundancy Check Memory Sca...

27.5.3 Status

Name: STATUS
Offset: 0x02
Reset: 0x02
Property: -

Bit	7	6	5	4	3	2	1	0
Access							R	R
Reset							1	0

Bit 1 – OK CRC OK

When this bit is read as '1', the previous CRC completed successfully. The bit is set to '1' by default before a CRC scan is run. The bit is not valid unless BUSY is '0'.

Bit 0 – BUSY CRC Busy

When this bit is read as '1', the CRCSCAN is busy. As long as the module is busy, the access to the control registers is limited.

28. CCL - Configurable Custom Logic

28.1 Features

- Glue Logic for General Purpose PCB Design
- Four Programmable Look-Up Tables (LUTs)
- Combinatorial Logic Functions: Any Logic Expression Which Is a Function of up to Three Inputs.
- Sequencer Logic Functions:
 - Gated D flip-flop
 - JK flip-flop
 - Gated D latch
 - RS latch
- Flexible LUT Input Selection:
 - I/Os
 - Events
 - Subsequent LUT output
 - Internal peripherals such as:
 - Analog comparator
 - Timers/Counters
 - USART
 - SPI
- Clocked by a System Clock or Other Peripherals
- Output Can Be Connected to I/O Pins or an Event System
- Optional Synchronizer, Filter, or Edge Detector Available on Each LUT Output
- Optional Interrupt Generation from Each LUT Output:
 - Rising edge
 - Falling edge
 - Both edges

28.2 Overview

The Configurable Custom Logic (CCL) is a programmable logic peripheral which can be connected to the device pins, to events, or to other internal peripherals. The CCL can serve as 'glue logic' between the device peripherals and external devices. The CCL can eliminate the need for external logic components, and can also help the designer to overcome real-time constraints by combining Core Independent Peripherals (CIPs) to handle the most time-critical parts of the application independent of the CPU.

The CCL peripheral provides a number of Look-up Tables (LUTs). Each LUT consists of three inputs, a truth table, a synchronizer/filter, and an edge detector. Each LUT can generate an output as a user programmable logic expression with three inputs. The output is generated from the inputs using the combinatorial logic and can be filtered to remove spikes. The CCL can be configured to generate an interrupt request on changes in the LUT outputs.

Neighboring LUTs can be combined to perform specific operations. A sequencer can be used for generating complex waveforms.

28.2.1 Block Diagram

Figure 28-1. CCL Block Diagram

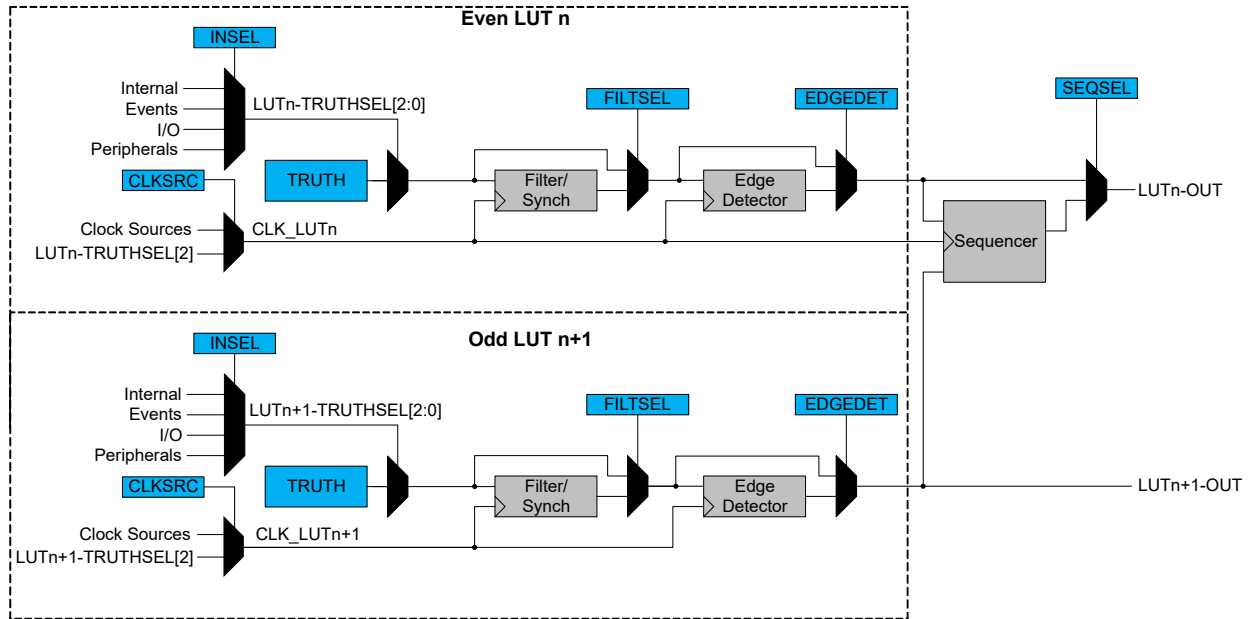

Table 28-2. Sequencer and LUT Connection

Sequencer	Even and Odd LUT
SEQ0	LUT0 and LUT1
SEQ1	LUT2 and LUT3

28.2.2 Signal Description

Name	Type	Description
LUTn-OUT	Digital output	Output from the Look-up Table
LUTn-IN[2:0]	Digital input	Input to the Look-up Table. LUTn-IN[2] can serve as CLK_LUTn.

Refer to the *I/O Multiplexing and Considerations* section for details on the pin mapping for this peripheral. One signal can be mapped to several pins.

28.2.2.1 CCL Input Selection MUX

The following peripherals outputs are available as inputs into the CCL LUT.

Value	Input Source	INSEL0[3:0]	INSEL1[3:0]	INSEL2[3:0]
0x00	MASK		None	
0x01	FEEDBACK		LUTn	
0x02	LINK		LUT(n+1)	
0x03	EVENTA		EVENTA	
0x04	EVENTB		EVENTB	
0x05	IO	IN0	IN1	IN2
0x06	AC0		AC0 OUT	
0x07	-		-	

.....continued

Value	Input Source	INSEL0[3:0]	INSEL1[3:0]	INSEL2[3:0]
0x08 ⁽¹⁾	USARTn	USART0 TXD	USART1 TXD	-
0x09 ⁽²⁾	SPI	SPI0 MOSI	SPI0 MOSI	SPI0 SCK
0x0A	TCA0	WO0	WO1	WO2
0x0B	-	-		
0x0C	TCB	TCB0 WO	TCB1 WO	-

Notes:

1. USART connections to the CCL work only in asynchronous/synchronous USART host mode.
2. SPI connections to the CCL work only in host SPI mode.

28.3 Functional Description

28.3.1 Operation

28.3.1.1 Enable-Protected Configuration

The configuration of the LUTs and sequencers is enable-protected, meaning that they can only be configured when the corresponding even LUT is disabled (ENABLE = '0' in the LUT n Control A (CCL.LUTnCTRLA) register). This is a mechanism to suppress the undesired output from the CCL under (re-)configuration.

The following bits and registers are enable-protected:

- Sequencer Selection (SEQSEL) in the Sequencer Control n (CCL.SEQCTRLn) registers
- LUT n Control x (CCL.LUTnCTRLx) registers, except the ENABLE bit in the CCL.LUTnCTRLA register
- TRUTHn (CCL.TRUTHn) registers

The enable-protected bits in the CCL.LUTnCTRLx registers can be written at the same time as ENABLE in CCL.LUTnCTRLA is written to '1', but not at the same time as ENABLE is written to '0'.

The enable protection is denoted by the enable-protected property in the register description.

28.3.1.2 Enabling, Disabling, and Resetting

The CCL is enabled by writing a '1' to the ENABLE bit in the Control A (CCL.CTRLA) register. The CCL is disabled by writing a '0' to that ENABLE bit.

Each LUT is enabled by writing a '1' to the LUT Enable (ENABLE) bit in the CCL.LUTnCTRLA register. Each LUT is disabled by writing a '0' to the ENABLE bit in the CCL.LUTnCTRLA register.

28.3.1.3 Truth Table Logic

The truth table in each LUT unit can generate a combinational logic output as a function of up to three inputs (LUTn-TRUTHSEL[2:0]). It is possible to realize any 3-input Boolean logic function using one LUT.

Figure 28-2. Truth Table Output Value Selection of an LUT

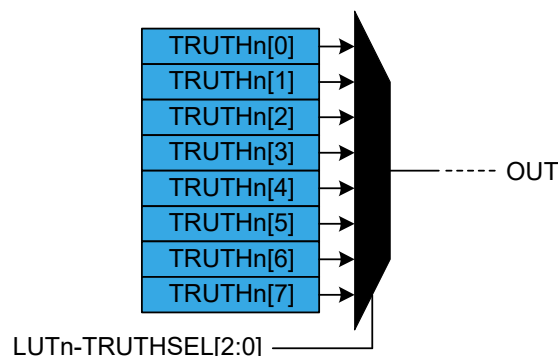

Configure the truth table inputs (LUTn-TRUTHSEL[2:0]) by writing the Input Source Selection bit fields in the LUT Control registers:

- INSEL0 in CCL.LUTnCTRLB
- INSEL1 in CCL.LUTnCTRLB
- INSEL2 in CCL.LUTnCTRLC

Each combination of the input bits (LUTn-TRUTHSEL[2:0]) corresponds to one bit in the CCL.TRUTHn register, as shown in the table below:

Table 28-3. Truth Table of an LUT

LUTn-TRUTHSEL[2]	LUTn-TRUTHSEL[1]	LUTn-TRUTHSEL[0]	OUT
0	0	0	TRUTHn[0]
0	0	1	TRUTHn[1]
0	1	0	TRUTHn[2]
0	1	1	TRUTHn[3]
1	0	0	TRUTHn[4]
1	0	1	TRUTHn[5]
1	1	0	TRUTHn[6]
1	1	1	TRUTHn[7]



Important: Consider the unused inputs turned off (tied low) when logic functions are created.

Example 28-1. LUT Output for CCL.TRUTHn = 0x42

If CCL.TRUTHn is configured to 0x42, the LUT output will be 1 when the inputs are 'b001 or 'b110 and 0 for any other combination of inputs.

28.3.1.4 Truth Table Inputs Selection

Input Overview

The inputs can be individually:

- OFF
- Driven by peripherals
- Driven by internal events from the Event System
- Driven by I/O pin inputs
- Driven by other LUTs

Internal Feedback Inputs (FEEDBACK)

The output from a sequencer can be used as an input source for the two LUTs it is connected to.

Figure 28-3. Feedback Input Selection

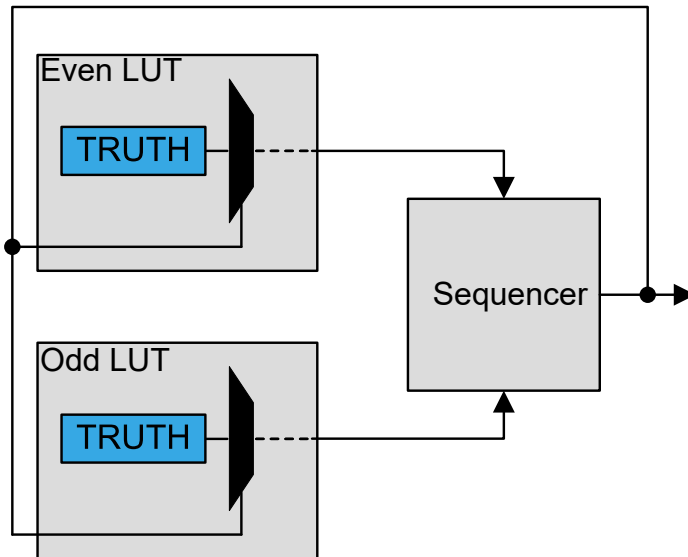

When selected (INSELY = FEEDBACK in LUTnCTRLx), the sequencer (SEQ) output is used as input for the corresponding LUTs.

Linked LUT (LINK)

When selecting the LINK input option, the next LUT's direct output is used as LUT input. In general, LUT[n+1] is linked to the input of LUT[n]. LUT0 is linked to the input of the last LUT.

Example 28-2. Linking all LUTs on a Device with Four LUTs

- LUT1 is the input for LUT0
- LUT2 is the input for LUT1
- LUT3 is the input for LUT2
- LUT0 is the input for LUT3 (wrap-around)

Figure 28-4. Linked LUT Input Selection

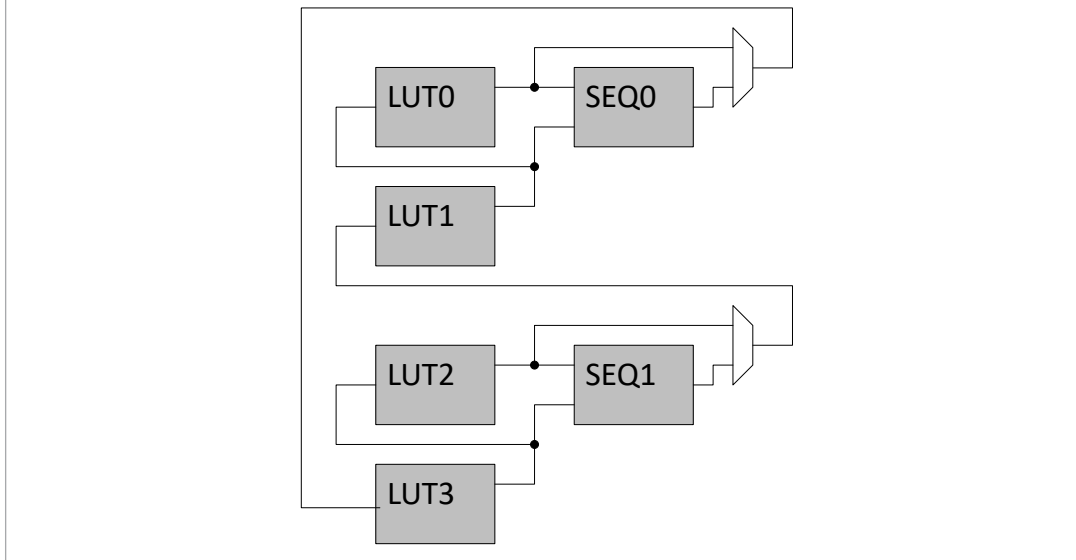

Event Input Selection (EVENTx)

Events from the Event System can be used as inputs to the LUTs by writing to the INSELn bit groups in the LUT n Control B and C registers.

I/O Pin Inputs (IO)

When selecting the IO option, the LUT input will be connected to its corresponding I/O pin. Refer to the *I/O Multiplexing and Considerations* section in the data sheet for more details about where the LUTn-INy pins are located.

Peripherals

The different peripherals on the three input lines of each LUT are selected by writing to the Input Select (INSEL) bits in the LUT Control (LUTnCTRLB and LUTnCTRLC) registers.

28.3.1.5 Filter

By default, the LUT output is a combinational function of the LUT inputs. This may cause some short glitches when the inputs change the value. These glitches can be removed by clocking through filters if demanded by application needs.

The Filter Selection (FILTSEL) bits in the LUT n Control A (CCL.LUTnCTRLA) registers define the digital filter options.

When `FILTSEL = SYNCH`, the output is synchronized with `CLK_LUTn`. The output will be delayed by two positive `CLK_LUTn` edges.

When `FILTSEL = FILTER`, only the input that is persistent for more than two positive `CLK_LUTn` edges will pass through the gated flip-flop to the output. The output will be delayed by four positive `CLK_LUTn` edges.

One clock cycle later, after the corresponding LUT is disabled, all internal filter logic is cleared.

Figure 28-5. Filter

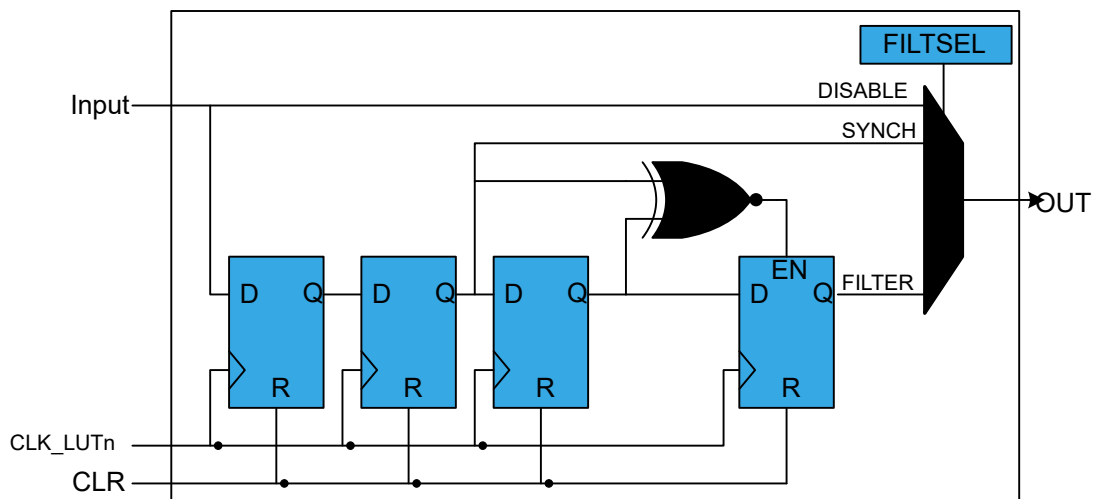

28.3.1.6 Edge Detector

The edge detector can be used to generate a pulse when detecting a rising edge on its input. To detect a falling edge, the TRUTH table can be programmed to provide an inverted output.

The edge detector is enabled by writing '1' to the Edge Detection (EDGEDET) bit in the LUTn Control A (CCL.LUTnCTRLA) register. To avoid unpredictable behavior, a valid filter option must be enabled.

The edge detection is disabled by writing a '0' to EDGEDET in CCL.LUTnCTRLA. After disabling an LUT, the corresponding internal edge detector logic is cleared one clock cycle later.

Figure 28-6. Edge Detector

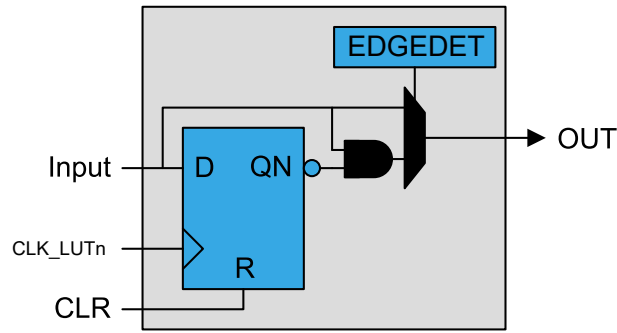

28.3.1.7 Sequencer Logic

Each LUT pair can be connected to a sequencer. The sequencer can function as either D flip-flop, JK flip-flop, gated D latch, or RS latch. The function is selected by writing the Sequencer Selection (SEQSEL) bit group in the Sequencer Control (CCL.SEQCTRLn) register.

The sequencer receives its input from either the LUT, filter or edge detector, depending on the configuration.

A sequencer is clocked by the same clock as the corresponding even LUT. The clock source is selected by the Clock Source (CLKSRC) bit group in the LUT n Control A (CCL.LUTnCTRLA) register.

The flip-flop output (OUT) is refreshed on the rising edge of the clock. When the even LUT is disabled, the latch is cleared asynchronously. The flip-flop Reset signal (R) is kept enabled for one clock cycle.

Gated D Flip-Flop (DFF)

The D input is driven by the even LUT output, and the G input is driven by the odd LUT output.

Figure 28-7. D Flip-Flop

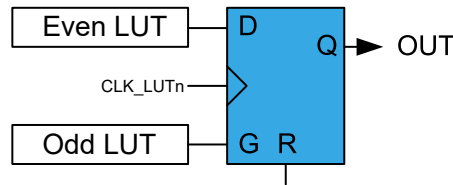

Table 28-4. DFF Characteristics

R	G	D	OUT
1	X	X	Clear
0	1	1	Set
0	1	0	Clear
0	0	X	Hold state (no change)

JK Flip-Flop (JK)

The J input is driven by the even LUT output, and the K input is driven by the odd LUT output.

Figure 28-8. JK Flip-Flop

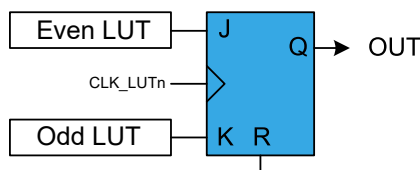

Table 28-5. JK Characteristics

R	J	K	OUT
1	X	X	Clear
0	0	0	Hold state (no change)
0	0	1	Clear
0	1	0	Set
0	1	1	Toggle

Gated D Latch (DLATCH)

The D input is driven by the even LUT output, and the G input is driven by the odd LUT output.

Figure 28-9. D Latch

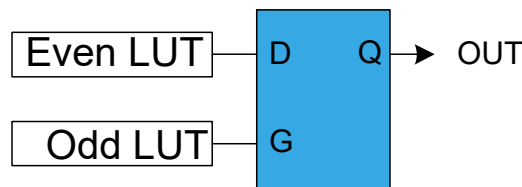

Table 28-6. D Latch Characteristics

G	D	OUT
0	X	Hold state (no change)
1	0	Clear
1	1	Set

RS Latch (RS)

The S input is driven by the even LUT output, and the R input is driven by the odd LUT output.

Figure 28-10. RS Latch

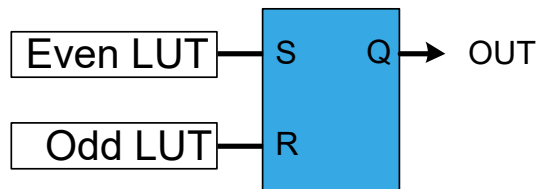

Table 28-7. RS Latch Characteristics

S	R	OUT
0	0	Hold state (no change)
0	1	Clear
1	0	Set
1	1	Forbidden state

28.3.1.8 Clock Source Settings

The filter, edge detector, and sequencer are, by default, clocked by the peripheral clock (CLK_PER). It is also possible to use other clock inputs (CLK_LUTn) to clock these blocks. This is configured by writing the Clock Source (CLKSRC) bits in the LUT Control A register.

Figure 28-11. CCL Clock Sources

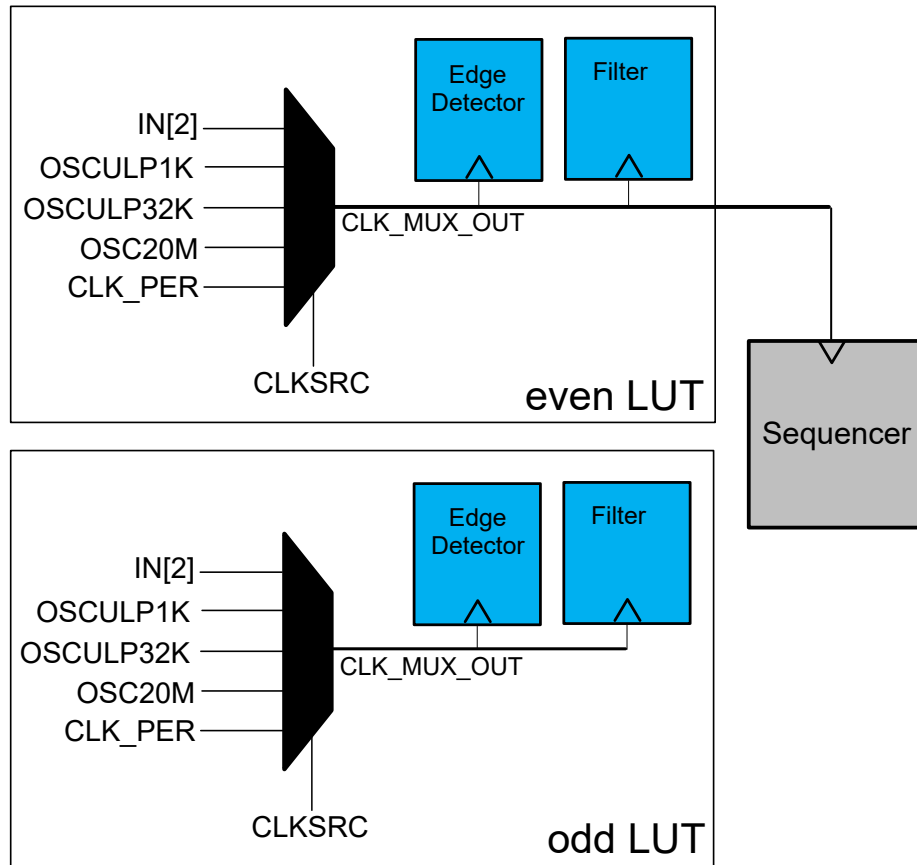

When the Clock Source (CLKSRC) bit is written to 0×1 , LUTn-TRUTHSEL[2] is used to clock the corresponding filter and edge detector (CLK_LUTn). The sequencer is clocked by the CLK_LUTn of the even LUT in the pair. When CLKSRC is written to 0×1 , LUTn-TRUTHSEL[2] is treated as OFF (low) in the TRUTH table.

The CCL peripheral must be disabled while changing the clock source to avoid undefined outputs from the peripheral.

28.3.2 Interrupts

Table 28-8. Available Interrupt Vectors and Sources

Name	Vector Description	Conditions
CCL	CCL interrupt	INTn in INTFLAG is raised as configured by the INTMODEn bits in the CCL.INTCTRLn register

When an interrupt condition occurs, the corresponding interrupt flag is set in the peripheral's Interrupt Flags (*peripheral*.INTFLAGS) register.

An interrupt source is enabled or disabled by writing to the corresponding enable bit in the peripheral's Interrupt Control (*peripheral*.INTCTRL) register.

An interrupt request is generated when the corresponding interrupt source is enabled, and the interrupt flag is set. The interrupt request remains active until the interrupt flag is cleared. See the peripheral's INTFLAGS register for details on how to clear interrupt flags.

When several interrupt request conditions are supported by an interrupt vector, the interrupt requests are ORed together into one combined interrupt request to the interrupt controller. The user must read the peripheral's INTFLAGS register to determine which of the interrupt conditions are present.

28.3.3 Events

The CCL can generate the events shown in the table below.

Table 28-9. Event Generators in the CCL

Generator Name		Description	Event Type	Generating Clock Domain	Length of Event
Peripheral	Event				
CCL	LUTn	LUT output level	Level	Asynchronous	Depends on the CCL configuration

The CCL has the event users below for detecting and acting upon input events.

Table 28-10. Event Users in the CCL

User Name		Description	Input Detection	Async/Sync
Peripheral	Input			
CCL	LUTnx	LUTn input x or clock signal	No detection	Async

The event signals are passed directly to the LUTs without synchronization or input detection logic.

Two event users are available for each LUT. They can be selected as LUTn inputs by writing to the INSELn bit groups in the LUT n Control B and Control C (CCL.LUTnCTRLB or LUTnCTRLC) registers.

Refer to the *EVSYS - Event System* section for more details regarding the event types and the EVSYS configuration.

28.3.4 Sleep Mode Operation

Writing the Run In Standby (RUNSTDBY) bit in the Control A (CCL.CTRLA) register to '1' will allow the selected clock source to be enabled in Standby sleep mode.

If RUNSTDBY is '0', the peripheral clock will be disabled in Standby sleep mode. If the filter, edge detector, and/or sequencer are enabled, the LUT output will be forced to '0' in Standby sleep mode. In Idle sleep mode, the TRUTH table decoder will continue the operation, and the LUT output will be refreshed accordingly, regardless of the RUNSTDBY bit.

If the Clock Source (CLKSRC) bit in the LUT n Control A (CCL.LUTnCTRLA) register is written to '1', the LUTn-TRUTHSEL[2] will always clock the filter, edge detector, and sequencer. The availability of the LUTn-TRUTHSEL[2] clock in sleep modes will depend on the sleep settings of the peripheral used.

28.4 Register Summary

Offset	Name	Bit Pos.	7	6	5	4	3	2	1	0	
0x00	CTRLA	7:0		RUNSTDBY						ENABLE	
0x01	SEQCTRL0	7:0						SEQSEL0[3:0]			
0x02	SEQCTRL1	7:0						SEQSEL1[3:0]			
0x03	Reserved										
0x04											
0x05	INTCTRL0	7:0	INTMODE3[1:0]		INTMODE2[1:0]		INTMODE1[1:0]		INTMODE0[1:0]		
0x06	Reserved										
0x07	INTFLAGS	7:0					INT3	INT2	INT1	INT0	
0x08	LUT0CTRLA	7:0	EDGEDET	OUTEN	FILTSEL[1:0]		CLKSRC[2:0]		ENABLE		
0x09	LUT0CTRLB	7:0	INSEL1[3:0]				INSEL0[3:0]				
0x0A	LUT0CTRLC	7:0					INSEL2[3:0]				
0x0B	TRUTH0	7:0	TRUTH0[7:0]								
0x0C	LUT1CTRLA	7:0	EDGEDET	OUTEN	FILTSEL[1:0]		CLKSRC[2:0]		ENABLE		
0x0D	LUT1CTRLB	7:0	INSEL1[3:0]				INSEL0[3:0]				
0x0E	LUT1CTRLC	7:0					INSEL2[3:0]				
0x0F	TRUTH1	7:0	TRUTH1[7:0]								
0x10	LUT2CTRLA	7:0	EDGEDET	OUTEN	FILTSEL[1:0]		CLKSRC[2:0]		ENABLE		
0x11	LUT2CTRLB	7:0	INSEL1[3:0]				INSEL0[3:0]				
0x12	LUT2CTRLC	7:0					INSEL2[3:0]				
0x13	TRUTH2	7:0	TRUTH2[7:0]								
0x14	LUT3CTRLA	7:0	EDGEDET	OUTEN	FILTSEL[1:0]		CLKSRC[2:0]		ENABLE		
0x15	LUT3CTRLB	7:0	INSEL1[3:0]				INSEL0[3:0]				
0x16	LUT3CTRLC	7:0					INSEL2[3:0]				
0x17	TRUTH3	7:0	TRUTH3[7:0]								

28.5 Register Description

28.5.1 Control A

Name: CTRLA
Offset: 0x00
Reset: 0x00
Property: -

	Bit	7	6	5	4	3	2	1	0
			RUNSTDBY						ENABLE
Access			R/W						R/W
Reset			0						0

Bit 6 – RUNSTDBY Run in Standby

Writing this bit to '1' will enable the peripheral to run in Standby sleep mode.

Value	Description
0	The CCL will not run in Standby sleep mode
1	The CCL will run in Standby sleep mode

Bit 0 – ENABLE Enable

Value	Description
0	The peripheral is disabled
1	The peripheral is enabled

28.5.2 Sequencer Control 0

Name: SEQCTRL0
Offset: 0x01
Reset: 0x00
Property: Enable-Protected

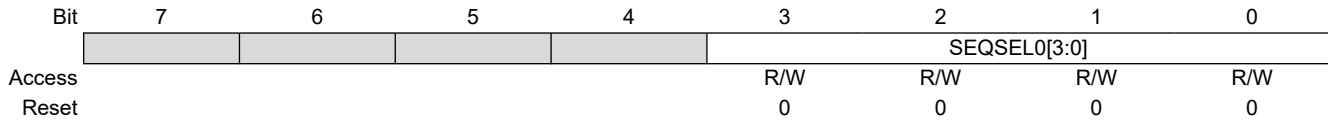

Bits 3:0 – SEQSEL0[3:0] Sequencer Selection

This bit group selects the sequencer configuration for LUT0 and LUT1.

Value	Name	Description
0x0	DISABLE	The sequencer is disabled
0x1	DFF	D flip-flop
0x2	JK	JK flip-flop
0x3	LATCH	D latch
0x4	RS	RS latch
Other	-	Reserved

28.5.3 Sequencer Control 1

Name: SEQCTRL1
Offset: 0x02
Reset: 0x00
Property: Enable-Protected

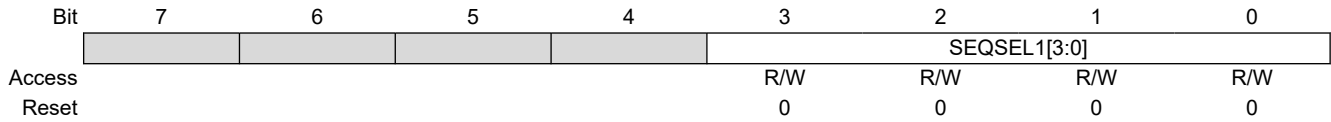

Bits 3:0 – SEQSEL1[3:0] Sequencer Selection

This bit group selects the sequencer configuration for LUT2 and LUT3.

Value	Name	Description
0x0	DISABLE	The sequencer is disabled
0x1	DFF	D flip-flop
0x2	JK	JK flip-flop
0x3	LATCH	D latch
0x4	RS	RS latch
Other	-	Reserved

28.5.4 Interrupt Control 0

Name: INTCTRL0
Offset: 0x05
Reset: 0x00
Property: -

Bit	7	6	5	4	3	2	1	0
	INTMODE3[1:0]		INTMODE2[1:0]		INTMODE1[1:0]		INTMODE0[1:0]	
Access	R/W	R/W	R/W	R/W	R/W	R/W	R/W	R/W
Reset	0	0	0	0	0	0	0	0

Bits 0:1, 2:3, 4:5, 6:7 – INTMODE

The bits in INTMODEn select the interrupt sense configuration for LUTn-OUT.

Value	Name	Description
0x0	INTDISABLE	Interrupt disabled
0x1	RISING	Sense rising edge
0x2	FALLING	Sense falling edge
0x3	BOTH	Sense both edges

28.5.5 Interrupt Flag

Name: INTFLAGS
Offset: 0x07
Reset: 0x00
Property: -

	7	6	5	4	3	2	1	0
Bit					INT3	INT2	INT1	INT0
Access					R/W	R/W	R/W	R/W
Reset					0	0	0	0

Bits 0, 1, 2, 3 – INT Interrupt Flag

The INTn flag is set when the LUTn output change matches the Interrupt Sense mode as defined in CCL.INTCTRLn. Writing a '1' to this flag's bit location will clear the flag.

28.5.6 LUT n Control A

Name: LUTnCTRLA
Offset: 0x08 + n*0x04 [n=0..3]
Reset: 0x00
Property: Enable-Protected

Bit	7	6	5	4	3	2	1	0
	EDGEDET	OUTEN	FILTSEL[1:0]			CLKSRC[2:0]		ENABLE
Access	R/W	R/W	R/W	R/W	R/W	R/W	R/W	R/W
Reset	0	0	0	0	0	0	0	0

Bit 7 – EDGEDET Edge Detection

Value	Description
0	Edge detector is disabled
1	Edge detector is enabled

Bit 6 – OUTEN Output Enable

This bit enables the LUT output to the LUTn OUT pin. When written to '1', the pin configuration of the PORT I/O-Controller is overridden.

Value	Description
0	Output to pin disabled
1	Output to pin enabled

Bits 5:4 – FILTSEL[1:0] Filter Selection

These bits select the LUT output filter options.

Value	Name	Description
0x0	DISABLE	Filter disabled
0x1	SYNCH	Synchronizer enabled
0x2	FILTER	Filter enabled
0x3	-	Reserved

Bits 3:1 – CLKSRC[2:0] Clock Source Selection

This bit selects between various clock sources to be used as the clock (CLK_LUTn) for an LUT. The CLK_LUTn of the even LUT is used for clocking the sequencer of an LUT pair.

Value	Name	Description
0x0	CLKPER	CLK_PER is clocking the LUT
0x1	IN2	LUTn-TRUTHSEL[2] is clocking the LUT
0x2	-	Reserved
0x3	-	Reserved
0x4	OSC20M	20 MHz oscillator before prescaler is clocking the LUT
0x5	OSKULP32K	32.768 kHz internal oscillator is clocking the LUT
0x6	OSKULP1K	1.024 kHz (OSKULP32K after DIV32) is clocking the LUT
0x7	-	Reserved

Bit 0 – ENABLE LUT Enable

Value	Description
0	The LUT is disabled
1	The LUT is enabled

28.5.7 LUT n Control B

Name: LUTnCTRLB
Offset: 0x09 + n*0x04 [n=0..3]
Reset: 0x00
Property: Enable-Protected

Notes:

1. SPI connections to the CCL work in Host SPI mode only.
2. USART connections to the CCL work only when the USART is in one of the following modes:
 - Asynchronous USART
 - Synchronous USART host

	7	6	5	4	3	2	1	0
	INSEL1[3:0]				INSEL0[3:0]			
Access	R/W	R/W	R/W	R/W	R/W	R/W	R/W	R/W
Reset	0	0	0	0	0	0	0	0

Bits 7:4 – INSEL1[3:0] LUT n Input 1 Source Selection

These bits select the source for input 1 of LUT n.

Value	Name	Description
0x0	MASK	Masked input
0x1	FEEDBACK	Feedback input
0x2	LINK	Output from LUT(n+1) as input source
0x3	EVENTA	Event A as input source
0x4	EVENTB	Event B as input source
0x5	IO	IN1 input source
0x6	AC0	AC0 OUT input source
0x7	-	Reserved
0x8	USART1	USART1 TXD input source
0x9	SPI0	SPI0 MOSI input source
0xA	TCA0	TCA0 WO1 input source
0xB	-	Reserved
0xC	TCB1	TCB1 WO input source
Other	-	Reserved

Bits 3:0 – INSEL0[3:0] LUT n Input 0 Source Selection

These bits select the source for input 0 of LUT n.

Value	Name	Description
0x0	MASK	Masked input
0x1	FEEDBACK	Feedback input
0x2	LINK	Output from LUT(n+1) as input source
0x3	EVENTA	Event A as input source
0x4	EVENTB	Event B as input source
0x5	IO	IN0 input source
0x6	AC0	AC0 OUT input source
0x7	-	Reserved
0x8	USART0	USART0 TXD input source
0x9	SPI0	SPI0 MOSI input source
0xA	TCA0	TCA0 WO0 input source
0xB	-	Reserved
0xC	TCB0	TCB0 WO input source
Other	-	Reserved

28.5.8 LUT n Control C

Name: LUTnCTRLC
Offset: 0x0A + n*0x04 [n=0..3]
Reset: 0x00
Property: Enable-Protected

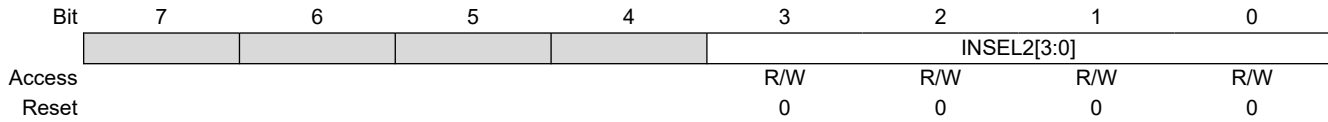

Bits 3:0 – INSEL2[3:0] LUT n Input 2 Source Selection
 These bits select the source for input 2 of LUT n.

Value	Name	Description
0x0	MASK	Masked input
0x1	FEEDBACK	Feedback input
0x2	LINK	Output from LUT(n+1) as input source
0x3	EVENTA	Event A as input source
0x4	EVENTB	Event B as input source
0x5	IO	IN2 input source
0x6	AC0	AC0 OUT input source
0x7	-	Reserved
0x8	-	Reserved
0x9	SPI0	SPI0 SCK input source
0xA	TCA0	TCA0 WO2 input source
Other	-	Reserved

28.5.9 TRUTHn

Name: TRUTHn
Offset: 0x0B + n*0x04 [n=0..3]
Reset: 0x00
Property: Enable-Protected

	7	6	5	4	3	2	1	0
	TRUTHn[7:0]							
Access	R/W	R/W	R/W	R/W	R/W	R/W	R/W	R/W
Reset	0	0	0	0	0	0	0	0

Bits 7:0 – TRUTHn[7:0] Truth Table

These bits determine the output of LUTn according to the LUTn-TRUTHSEL[2:0] inputs.

Bit Name	Value	Description
TRUTHn[0]	0	The output of LUTn is 0 when the inputs are 'b000
	1	The output of LUTn is 1 when the inputs are 'b000
TRUTHn[1]	0	The output of LUTn is 0 when the inputs are 'b001
	1	The output of LUTn is 1 when the inputs are 'b001
TRUTHn[2]	0	The output of LUTn is 0 when the inputs are 'b010
	1	The output of LUTn is 1 when the inputs are 'b010
TRUTHn[3]	0	The output of LUTn is 0 when the inputs are 'b011
	1	The output of LUTn is 1 when the inputs are 'b011
TRUTHn[4]	0	The output of LUTn is 0 when the inputs are 'b100
	1	The output of LUTn is 1 when the inputs are 'b100
TRUTHn[5]	0	The output of LUTn is 0 when the inputs are 'b101
	1	The output of LUTn is 1 when the inputs are 'b101
TRUTHn[6]	0	The output of LUTn is 0 when the inputs are 'b110
	1	The output of LUTn is 1 when the inputs are 'b110
TRUTHn[7]	0	The output of LUTn is 0 when the inputs are 'b111
	1	The output of LUTn is 1 when the inputs are 'b111

29. AC - Analog Comparator

29.1 Features

- Selectable Response Time
- Selectable Hysteresis
- Analog Comparator Output Available on Pin
- Comparator Output Inversion Available
- Flexible Input Selection:
 - Up to four Positive pins
 - Up to three Negative pins
 - Internal reference voltage generator (DACREF)
- Interrupt Generation on:
 - Rising edge
 - Falling edge
 - Both edges
- Event Generation:
 - Comparator output

29.2 Overview

The analog comparator (AC) compares the voltage levels on two inputs and gives a digital output based on this comparison. The AC can be configured to generate interrupt requests and/or events upon several different combinations of input change.

The dynamic behavior of the AC can be adjusted by a hysteresis feature. The hysteresis can be customized to optimize the operation for each application.

The input selection includes analog port pins and internally generated inputs. The analog comparator output state can also be the output on a pin for use by external devices.

An AC has one positive input and one negative input. The digital output from the comparator is '1' when the difference between the positive and the negative input voltage is positive, and '0' otherwise.

29.2.1 Block Diagram

Figure 29-1. Analog Comparator

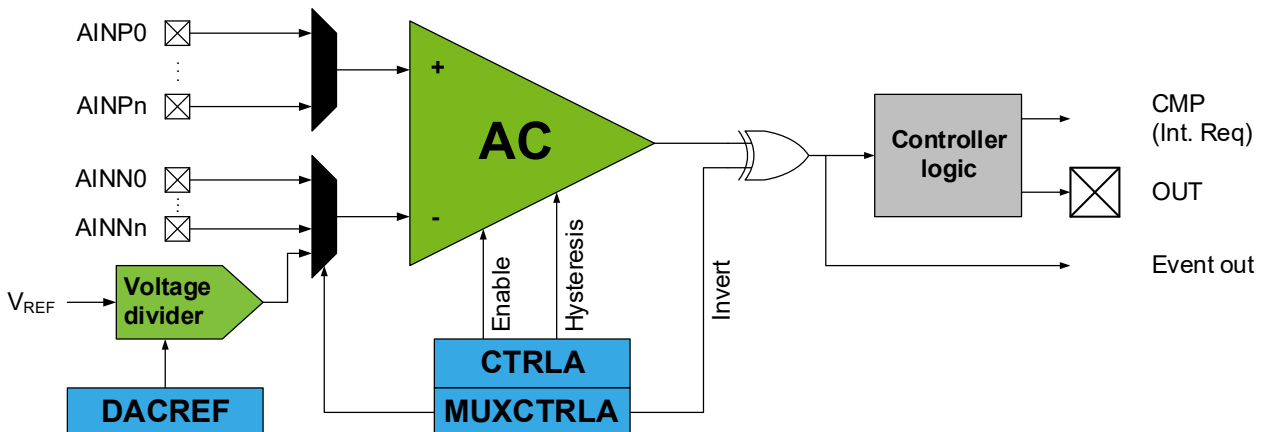

29.2.2 Signal Description

Signal	Description	Type
AINNn	Negative Input n	Analog
AINPn	Positive Input n	Analog
OUT	Comparator Output for AC	Digital

29.3 Functional Description

29.3.1 Initialization

For a basic operation, follow these steps:

- Configure the desired input pins in the port peripheral.
- Select the positive and negative input sources by writing the Positive and Negative Input MUX Selection bit fields (MUXPOS and MUXNEG) in the MUX Control A register (ACn.MUXCTRLA).
- Optional: Enable the output to pin by writing a '1' to the Output Pad Enable bit (OUTEN) in the Control A register (ACn.CTRLA).
- Enable the AC by writing a '1' to the ENABLE bit in ACn.CTRLA.

During the start-up time after enabling the AC, the output of the AC may be invalid.

The start-up time of the AC by itself is at most 2.5 μ s. If an internal reference is used, the reference start-up time is normally longer than the AC start-up time.

To avoid the pin being tri-stated when the AC is disabled, the OUT pin must be configured as output in PORTx.DIR.

29.3.2 Operation

29.3.2.1 Input Hysteresis

Applying an input hysteresis helps to prevent constant toggling of the output when the noise-afflicted input signals are close to each other.

The input hysteresis can either be disabled or have one of three levels. The hysteresis is configured by writing to the Hysteresis Mode Select bit field (HYSMODE) in the Control A register (ACn.CTRLA).

29.3.2.2 Input Sources

An AC has one positive and one negative input. The inputs can be pins and internal sources, such as a voltage reference.

Each input is selected by writing to the Positive and Negative Input MUX Selection bit field (MUXPOS and MUXNEG) in the MUX Control A register (ACn.MUXCTRLA).

29.3.2.2.1 Pin Inputs

The following analog input pins on the port can be selected as input to the analog comparator:

- AINN0
- AINN1
- AINN2
- AINP0
- AINP1
- AINP2
- AINP3

29.3.2.2.2 Internal Inputs

The AC has the following internal inputs:

- Internal reference voltage generator (DACREF)

29.3.2.3 Power Modes

For power sensitive applications, the AC provides a low-power mode with lower power consumption and increased propagation delay. The low-power mode is selected by writing the Low Power Mode (LPMODE) bit in the Control A (ACn.CTRLA) register to '1'.

29.3.2.4 Signal Compare and Interrupt

After the successful initialization of the AC and after configuring the desired properties, the result of the comparison is continuously updated and is available for the application software, for the Event System, or on a pin.

The AC can generate a comparator interrupt, COMP, and can request this interrupt on either rising, falling, or both edges of the toggling comparator output. This is configured by writing to the Interrupt Modes bit field in the Control A register (INTMODE bits in ACn.CTRLA).

The interrupt is enabled by writing a '1' to the Analog Comparator Interrupt Enable bit in the Interrupt Control register (COMP bit in ACn.INTCTRL).

29.3.3 Events

The AC can generate the events described in the table below.

Table 29-1. Event Generators in AC

Generator Name		Description	Event Type	Generating Clock Domain	Length of Event
Peripheral	Event				
ACn	OUT	Comparator output level.	Level	Asynchronous	Given by AC output level

The AC has no event inputs.

29.3.4 Interrupts

Table 29-2. Available Interrupt Vectors and Sources

Name	Vector Description	Conditions
COMP	Analog comparator interrupt	AC output is toggling as configured by INTMODE in ACn.CTRLA

When an interrupt condition occurs, the corresponding Interrupt flag is set in the Status register (ACn.STATUS).

An interrupt source is enabled or disabled by writing to the corresponding bit in the peripheral's Interrupt Control register (ACn.INTCTRL).

An interrupt request is generated when the corresponding interrupt source is enabled and the Interrupt flag is set. The interrupt request remains active until the Interrupt flag is cleared. See the ACn.STATUS register description for details on how to clear the Interrupt flags.

29.3.5 Sleep Mode Operation

In Idle Sleep mode the AC will continue to operate as normal.

In Standby Sleep mode the AC is disabled by default. If the Run in Standby Sleep Mode bit (RUNSTDBY) in the Control A register (ACn.CTRLA) is written to '1', the AC will continue to operate as normal with event, interrupt and AC output on pad even if the CLK_PER is not running in Standby Sleep mode.

In Power-Down Sleep mode the AC and the output to the pad are disabled.

29.4 Register Summary

Offset	Name	Bit Pos.	7	6	5	4	3	2	1	0
0x00	CTRLA	7:0	RUNSTDBY	OUTEN	INTMODE[1:0]		LPMODE	HYSMODE[1:0]		ENABLE
0x01	Reserved									
0x02	MUXCTRLA	7:0	INVERT			MUXPOS[1:0]			MUXNEG[1:0]	
0x03	Reserved									
0x04	DACREF	7:0	DACREF[7:0]							
0x05	Reserved									
0x06	INTCTRL	7:0								CMP
0x07	STATUS	7:0				STATE				CMP

29.5 Register Description

29.5.1 Control A

Name: CTRLA
Offset: 0x00
Reset: 0x00
Property: -

	7	6	5	4	3	2	1	0
	RUNSTDBY	OUTEN	INTMODE[1:0]		LPMODE	HYSMODE[1:0]		ENABLE
Access	R/W	R/W	R/W	R/W	R/W	R/W	R/W	R/W
Reset	0	0	0	0	0	0	0	0

Bit 7 – RUNSTDBY Run in Standby Mode

Writing a '1' to this bit allows the AC to continue operation in Standby Sleep mode. Since the clock is stopped, interrupts and Status flags are not updated.

Value	Description
0	In Standby Sleep mode, the peripheral is halted
1	In Standby Sleep mode, the peripheral continues operation

Bit 6 – OUTEN Analog Comparator Output Pad Enable

Writing this bit to '1' makes the OUT signal available on the pin.

Bits 5:4 – INTMODE[1:0] Interrupt Modes

Writing to these bits selects which edges of the AC output triggers an interrupt request.

Table 29-3. Interrupts in Regular Mode

Value	Name	Description
0x0	BOTHEDGE	Both negative and positive edge
0x1	-	Reserved
0x2	NEGEDGE	Negative edge
0x3	POSEDGE	Positive edge

Bit 3 – LPMODE Low-Power Mode

Writing a '1' to this bit reduces the current through the comparator. This reduces the power consumption, but increases the reaction time of the AC.

Value	Description
0	Low-Power mode disabled
1	Low-Power mode enabled

Bits 2:1 – HYSMODE[1:0] Hysteresis Mode Select

Writing these bits selects the Hysteresis mode for the AC input.

Value	Name	Description
0x0	NONE	No hysteresis
0x1	SMALL	Small hysteresis
0x2	MEDIUM	Medium hysteresis
0x3	LARGE	Large hysteresis

Bit 0 – ENABLE Enable AC

Writing this bit to '1' enables the AC.

29.5.2 MUX Control A

Name: MUXCTRLA
Offset: 0x02
Reset: 0x00
Property: -

	7	6	5	4	3	2	1	0
	INVERT			MUXPOS[1:0]			MUXNEG[1:0]	
Access	R/W			R/W	R/W		R/W	R/W
Reset	0			0	0		0	0

Bit 7 – INVERT Invert AC Output

Writing this bit to '1' enables inversion of the output of the AC. This inversion has to be taken into account when using the AC output signal as an input signal to other peripherals or parts of the system.

Bits 4:3 – MUXPOS[1:0] Positive Input MUX Selection

Writing to this bit field selects the input signal to the positive input of the AC.

Value	Name	Description
0x0	AINP0	Positive pin 0
0x1	AINP1	Positive pin 1
0x2	AINP2	Positive pin 2
0x3	AINP3	Positive pin 3

Bits 1:0 – MUXNEG[1:0] Negative Input MUX Selection

Writing to this bit field selects the input signal to the negative input of the AC.

Value	Name	Description
0x0	AINN0	Negative pin 0
0x1	AINN1	Negative pin 1
0x2	AINN2	Negative pin 2
0x3	DACREF	Voltage reference

29.5.3 DAC Voltage Reference

Name: DACREF
Offset: 0x04
Reset: 0xFF
Property: R/W

Bit	7	6	5	4	3	2	1	0
	DACREF[7:0]							
Access	R/W	R/W	R/W	R/W	R/W	R/W	R/W	R/W
Reset	1	1	1	1	1	1	1	1

Bits 7:0 – DACREF[7:0] DACREF Data Value

These bits define the output voltage from the internal voltage divider. The DAC voltage reference depends on the DACREF value and the reference voltage selected in the V_{REF} module, and is calculated as:

$$V_{DACREF} = \frac{DACREF}{256} \times V_{REF}$$

29.5.4 Interrupt Control

Name: INTCTRL
Offset: 0x06
Reset: 0x00
Property: -

Bit	7	6	5	4	3	2	1	0
Access								CMP
Reset								0

Bit 0 – CMP Analog Comparator Interrupt Enable
Writing this bit to '1' enables the Analog Comparator Interrupt.

29.5.5 Status

Name: STATUS
Offset: 0x07
Reset: 0x00
Property: -

Bit	7	6	5	4	3	2	1	0
				STATE				CMP
Access				R				R/W
Reset				0				0

Bit 4 – STATE Analog Comparator State

This bit shows the current status of the OUT signal from the AC. It will have a synchronizer delay to get updated in the I/O register (three cycles).

Bit 0 – CMP Analog Comparator Interrupt Flag

This is the interrupt flag for the AC. Writing a '1' to this bit will clear the interrupt flag.

30. ADC - Analog-to-Digital Converter

30.1 Features

- 12-Bit Resolution
 - Up to 17 bits with oversampling
- Conversion Rate Up to 375 ksps at 12-bit Resolution
- Up to 15 Inputs
- Differential and Single-Ended Conversion
- Programmable Gain Amplifier (PGA) from 1x to 16x
- Input Voltage Range from -100 mV to VDD+100 mV
- Multiple Internal ADC Reference Voltages
 - V_{DD}
 - 1.024V
 - 2.048V
 - 2.500V
 - 4.096V
- External Reference Input
- Single and Free-Running Conversions
- Series and Burst Accumulation Modes
- Accumulation of Up to 1024 Conversions
- Left or Right Adjusted Result
- Interrupts on Conversion Complete
- Optional Event Triggered Conversion
- Configurable Window Comparator

30.2 Overview

The Analog-to-Digital Converter (ADC) peripheral is a 12-bit differential and single-ended ADC, with a Programmable Gain Amplifier (PGA), and a conversion rate up to 375 ksps at 12-bit resolution. The ADC is connected to an analog input multiplexer for selection between multiple single-ended or differential inputs. In single-ended conversions, the ADC measures the voltage between the selected input and 0V (GND). In differential conversions, the ADC measures the voltage between two selected inputs. The ADC inputs can be either internal (for example, a voltage reference) or external analog input pins.

An ADC conversion can be started by software, or by using the Event System (EVSYS) to route an event from other peripherals. This makes it possible to sample input signals periodically, trigger an ADC conversion on a special condition, and also trigger ADC conversions in Standby sleep mode. A digital window compare feature is available for monitoring the input signal and can be configured to trigger an interrupt if the sample is under or over a user-defined threshold, or inside or outside a user-defined window, with minimum software intervention required.

The ADC input signal is fed through a sample-and-hold circuit that ensures the input voltage to the ADC is held at a constant level during the conversion.

The ADC supports sampling in bursts where a configurable number of samples are accumulated into a single ADC result (Sample Accumulation).

The ADC reference voltage can be either internal or supplied from the external analog reference pin (VREFA).

30.2.1 Block Diagram

Figure 30-1. Block Diagram

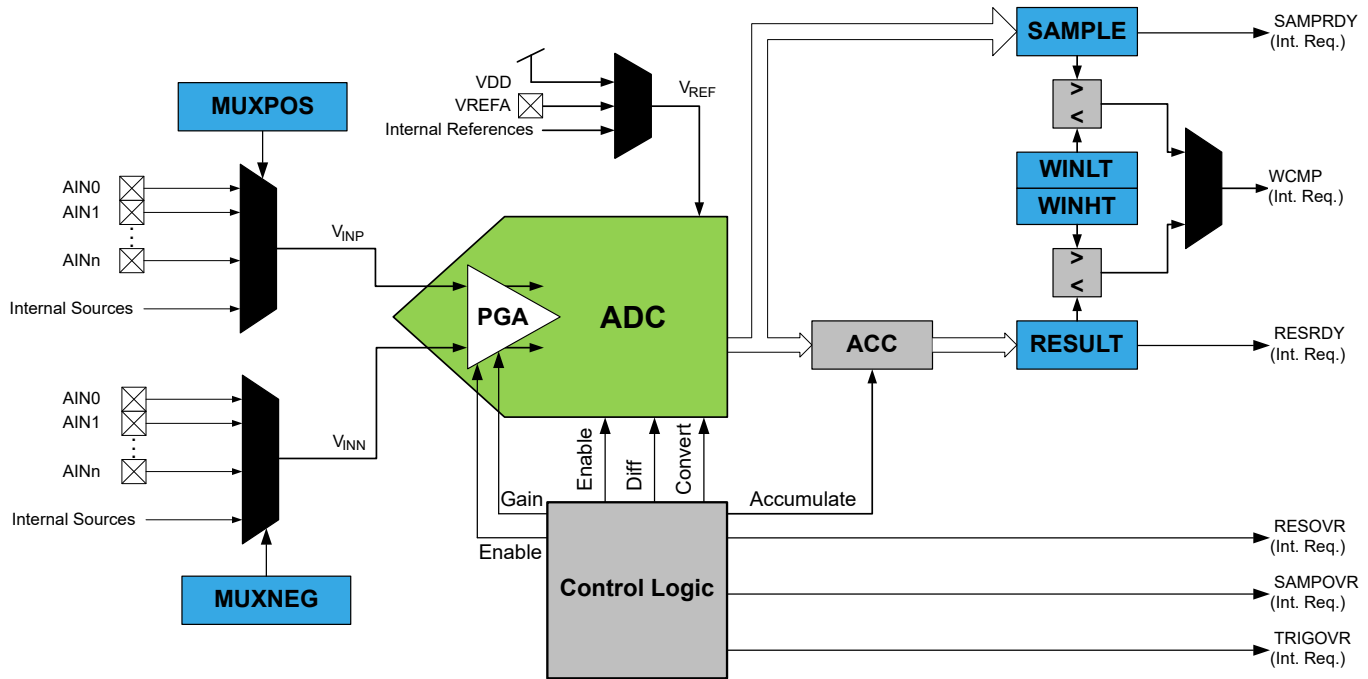

30.2.2 Signal Description

Pin Name	Type	Description
AIN[n:0]	Analog input	Analog input pin
VREFA	Analog input	External voltage reference pin

30.3 Functional Description

30.3.1 Definitions

- **Conversion:** The operation where analog values on the selected ADC inputs are transformed into a digital representation.
- **Sample:** The value placed in the Sample (ADCn.SAMPLE) register, that is, the outcome of a conversion operation.
- **Result:** The value placed in the Result (ADCn.RESULT) register. Depending on the ADC configuration, this value is a single sample or the sum of multiple accumulated samples.

30.3.2 Basic Operation

The following steps are recommended to initialize and run the ADC in basic operation:

1. Enable the ADC by writing a '1' to the ENABLE bit in the Control A (ADCn.CTRLA) register.
2. Configure the Prescaler (PRESC) bit field in the Control B (ADCn.CTRLB) register.
3. Configure the Timebase (TIMEBASE) and Reference Select (REFSEL) bit fields in the Control C (ADCn.CTRLC) register.
4. Configure the Sample Duration (SAMPDUR) bit field in the Control E (ADCn.CTRLE) register.

5. Optional: Configure the number of samples to be accumulated by writing the Sample Accumulation Number Select (SAMPNUM) bit field in the Control F (ADCn.CTRLF) register.
6. Optional: Enable the Free-Running mode by writing a '1' to the Free-Running (FREERUN) bit in the Control F register.
7. Configure a positive input by writing to the MUXPOS bit field in the Positive Input Multiplexer (ADCn.MUXPOS) register.
8. Optional: Configure a negative input by writing to the MUXNEG bit field in the Negative Input Multiplexer (ADCn.MUXNEG) register.
9. Optional: Select Differential ADC conversion by writing a '1' to the Differential (DIFF) bit in the Command (ADCn.COMMAND) register.
10. Configure the mode of operation for the ADC by writing to the MODE bit field in the Command register.
11. Configure how an ADC conversion will start by writing to the START bit field in the Command register. If the IMMEDIATE command is written, a conversion will start immediately.
12. Wait until the Result Ready (RESRDY) bit in the Interrupt Flags (ADCn.INTFLAGS) register is '1' before reading the updated Result (ADCn.RESULT) register.

30.3.3 Operation

30.3.3.1 Operation Modes

The ADC supports six different operation modes, with differential and single-ended conversions possible for each mode. This is configured in the Command (ADCn.COMMAND) register.

The operation modes can be split into three groups:

- Single mode - Single conversion per trigger, with 8- or 12-bit conversion output
- Series Accumulation mode - One conversion per trigger, with an accumulation of n samples
- Burst Accumulation mode - A burst with n samples accumulated as fast as possible after a single trigger

Series and Burst modes utilize 12-bit conversions and can be configured with or without scaling of the accumulated result. The number of samples to accumulate is controlled by the SAMPNUM bit in the Control F (ADCn.CTRLF) register. The accumulator is always reset to zero when a new Series or Burst accumulation is started.

The table below shows an overview of the available operation modes.

Table 30-1. Operation Modes

Operation Mode	COMMAND Mode	Conversions Per Trigger	Accumulation Type	RESULT Update
Single 8-bit	0	1	N/A	Every conversion
Single 12-bit	1			
Series Accumulation	2	1	Full	After SAMPNUM conversions
Series Accumulation with Scaling	3		Scaled	
Burst Accumulation	4	SAMPNUM	Full	After SAMPNUM conversions
Burst Accumulation with Scaling	5		Scaled	

30.3.3.2 Conversion Triggers

A conversion is started by one of the following triggers, depending on the configuration of the START bit field in the Command (ADCn.COMMAND) register:

- Writing the IMMEDIATE value to the START bit field in the Command register
- Receiving an event input
- Writing to one of the input multiplexer (ADCn.MUXPOS or ADCn.MUXNEG) registers

Continuously repeating Single conversions or Burst accumulations can be enabled by writing a '1' to the FREERUN bit in the Control F (ADCn.CTRLF) register before starting the first conversion. This bit has no effect for Series accumulations.

An ongoing conversion can be aborted by writing the STOP value to the START bit field in the Command register, and a new conversion can be started immediately. Triggering a new conversion before the ongoing conversion has finished will set the Trigger Overrun Interrupt (TRIGOVRR) flag in the Interrupt Flags (ADCn.INTFLAGS) register, and the trigger will be ignored.

The Result Ready and Sample Ready (RESRDY and SAMPRDY) interrupt flags in the Interrupt Flags register show if a conversion or accumulation has finished. These flags also trigger the corresponding interrupts if enabled in the Interrupt Control (ADCn.INTCTRL) register.

30.3.3.3 Output Formats

The output from an ADC conversion is given by the following equations:

$$\text{Single-Ended 12-bit conversion} = \frac{V_{\text{INP}} \times \text{Gain}}{V_{\text{REF}}} \times 4096 \in [0, 4095]$$

$$\text{Single-Ended 8-bit conversion} = \frac{V_{\text{INP}} \times \text{Gain}}{V_{\text{REF}}} \times 256 \in [0, 255]$$

$$\text{Differential 12-bit conversion} = \frac{(V_{\text{INP}} - V_{\text{INN}}) \times \text{Gain}}{V_{\text{REF}}} \times 2048 \in [-2048, 2047]$$

$$\text{Differential 8-bit conversion} = \frac{(V_{\text{INP}} - V_{\text{INN}}) \times \text{Gain}}{V_{\text{REF}}} \times 128 \in [-128, 127]$$

Where V_{INP} and V_{INN} are the positive and negative inputs to the ADC, and V_{REF} is the selected voltage reference. The gain is between 1x and 16x as configured in the PGA, and 1x if the PGA is not in use.

The ADC has two output registers, the Sample (ADCn.SAMPLE) and Result (ADCn.RESULT) registers. The 16-bit Sample register will always be updated with the latest ADC conversion output (one sample). All accumulation modes will accumulate samples in an internal sample accumulator, configured by the Sample Accumulation Number Select (SAMPNUM) bit field in the Control F (ADCn.CTRLF) register. The sample accumulator is sufficiently wide to avoid overflow for all supported accumulation configurations, and the accumulated result is automatically transferred to the 32-bit Result register at the end of a Burst or Series mode accumulation. In single conversion modes, the Result register will be updated with the latest sample, identical to the Sample register.

Operating modes with scaling can be selected to limit the accumulated result to 16 bits of resolution if more than 16 samples are accumulated. Scaling is always applied after accumulating the last sample in Burst or Series modes and is carried out by right shifting the accumulated result by SAMPNUM-4 bits.

The Left Adjust (LEFTADJ) bit in the Control F register enables left shift of the output data in the modes where this is supported. If enabled, this will left shift the output from both the Result and the Sample registers.

The data format for a sample in Single-Ended mode is an unsigned number, where 0x0000 represents zero, and 0x0FFF represents the largest number (full scale). If the analog input is higher than the reference level of the ADC, the 12-bit ADC output will be equal the maximum value of 0x0FFF. Likewise, if the input is below 0V, the ADC output will be 0x0000. For Differential mode, the data format is two's complement, with sign extension.

The following tables show the Result register output formats for single-ended and differential conversions, by mode of operation and left adjustment.

Table 30-2. RESULT Register - Single-Ended Mode

MODE	LEFTADJ	RES[31:24]	RES[23:16]	RES[15:12]	RES[11:8]	RES[7:0]	
0	X ⁽¹⁾	0x00				Conversion[7:0]	
1	0	0x00			Conversion[11:0]		
	1	0x00			Conversion[11:0] << 4		
2, 4	X ⁽¹⁾	0x00	Accumulation[23:0]				
3, 5	0	0x00			Scaled accumulation[15:0]		
	1	0x00			Scaled accumulation[15:0] ⁽²⁾		

Notes:

1. Left adjust is not available in 8-bit mode or accumulation modes without scaling.
2. If SAMPNUM < 4, the result is left-shifted 4-SAMPNUM bits such that bit 15 is the MSb.

Table 30-3. RESULT Register - Differential Mode

MODE	LEFTADJ	RES[31:24]	RES[23:16]	RES[15:12]	RES[11:8]	RES[7:0]	
0	X ⁽¹⁾	Sign extension				Signed conversion[7:0]	
1	0	Sign extension			Signed conversion[11:0]		
	1	Sign extension		Signed conversion[11:0] << 4			
2, 4	X ⁽¹⁾	Sign extension	Signed accumulation[23:0]				
3, 5	0	Sign extension		Signed scaled accumulation[15:0]			
	1	Sign extension		Signed scaled accumulation[15:0] ⁽²⁾			

Notes:

1. Left adjust is not available in 8-bit mode or accumulation modes without scaling.
2. If SAMPNUM < 4, the result is left-shifted 4-SAMPNUM bits such that bit 15 is the MSb.

The following table shows the Sample register output formats by mode of operation, left adjustment, and Differential or Single-Ended conversions.

Table 30-4. SAMPLE Register

MODE	LEFTADJ	DIFF	SAMPLE[15:12]	SAMPLE[11:8]	SAMPLE[7:0]
0	X	0	0x00		Conversion[7:0]
		1	Sign extension		Signed conversion[7:0]
Other	0	0	0x00	Conversion[11:0]	
		1	Sign extension	Signed conversion[11:0]	
	1	0	Conversion[11:0] << 4		
		1	Signed conversion[11:0] << 4		

30.3.3.4 ADC Clock

The ADC clock (CLK_ADC) is scaled down from the peripheral clock (CLK_PER). This can be configured by the Prescaler (PRESC) bit field in the Control B (ADCn.CTRLB) register. The PGA Bias Select (PGABIASEL) bit field in the PGA Control (ADCn.PGACTRL) register can be configured to reduce PGA power consumption depending on the ADC clock frequency.

Some of the internal timings in the ADC and the PGA are independent of CLK_ADC. To ensure correct internal timing regardless of the ADC clock frequency, a 1 μs timebase, given in CLK_PER cycles, must be written to the TIMEBASE bit field in the Control C (ADCn.CTRLA) register.

The timebase must be rounded up to the closest integer. The following code snippet shows how this can be done using the `ceil` function.

```
#include <math.h>
#define CLK_PER 3333333ul // 20 MHz/6 = 3.333333 MHz
#define TIMEBASE_VALUE ((uint8_t) ceil(CLK_PER*0.000001))
```

30.3.3.5 Input and Reference Selection

The input selection to the ADC is controlled by the Positive and Negative Input Multiplexer (ADCn.MUXPOS and ADCn.MUXNEG) registers. If the ADC is running single-ended conversions, only MUXPOS is used, while both are used in differential conversions.

The reference voltage for the ADC (V_{REF}) controls the conversion range of the ADC. V_{REF} can be selected by writing the Reference Selection (REFSEL) bit field in the Control C (ADCn.CTRLC) register. Except for V_{DD} , the internal reference voltages are generated from an internal band gap reference. V_{DD} must be at least 0.5V higher than the selected internal reference voltage.

The input and reference selections are not buffered. Changing any of these while a conversion is ongoing will corrupt the output. To safely change input or reference when using Free-Running mode, disable Free-Running mode, and wait for the conversion to complete before making any changes. Enable Free-Running mode again before starting the next conversion.

After switching input or reference, the ADC requires time to settle. Refer to the *Electrical Characteristics* section for further details.

30.3.3.5.1 Programmable Gain Amplifier

The Programmable Gain Amplifier (PGA) can be used to amplify the input signal to the ADC. The available range is from 1x to 16x gain. The PGA can be used in all operation modes.

In the default configuration, the PGA is disabled, and the input signals are sampled directly into the conversion stage, i.e., without internal amplification. It can be desirable to add the internal PGA stage to amplify the signal depending on the input signal properties.

The internal PGA has several desirable properties, especially in comparison to external amplifiers:

- Small BoM
- Low number of pins required
- Firmware selectable gain with input multiplexing allows for flexible and feature-rich applications
- Non-inverting amplification maintains signs/logic structure in firmware when the application requires to operate with PGA turned on and off

Using the PGA instead of direct inputs to the conversion stage has the following effects to consider:

- The input signal is amplified, with the natural side effects of an additional amplification stage (input noise, offset and gain error) and possible saturation
- The maximum conversion rate is slower because the ADC needs to sample the PGA
- Power consumption is slightly increased
- Depending on the sampling mode, the relative timing of the conversions is altered

The PGA is enabled by writing a '1' to the PGA Enable (PGAEN) bit and configuring the GAIN bit field in the PGA Control (ADCn.PGACTRL) register.

The VIA bit fields in the Positive and Negative Input Multiplexer (ADCn.MUXPOS and ADCn.MUXNEG) registers select if the input signal is connected via the PGA or not. The VIA bits are shared, so a value written to the VIA bit field in MUXPOS or MUXNEG is updated in both registers. It is, therefore, not possible to have one input using the PGA and the other not using the PGA.

30.3.3.5.2 Analog Input Circuit

The analog input circuit is illustrated in the figure below. An analog source connected to an analog input (AINn) is subject to the pin capacitance and input leakage of that pin (represented by I_H and I_L). When the input is selected, the source must also drive the Sample-Hold capacitor (C_{IN}) through the combined resistance of the input path (represented by R_{IN}). Refer to the *Electrical Characteristics* section for details on the input characteristics of the ADC.

Figure 30-2. Analog Input Schematic

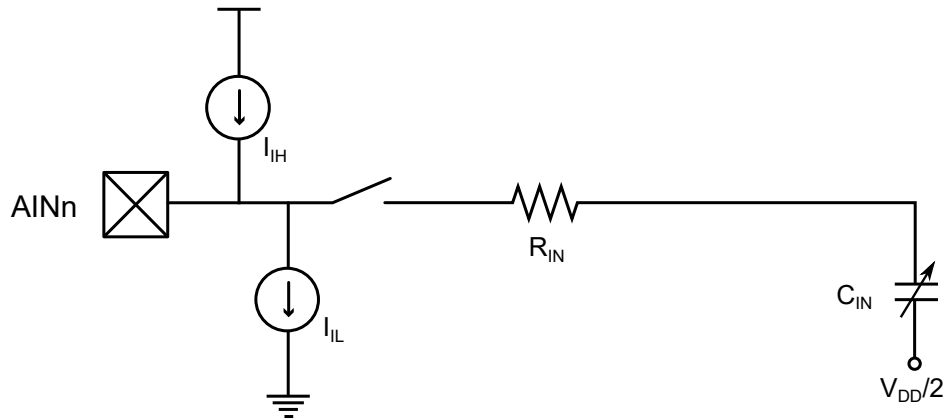

If a source with high impedance is used, the sampling time can be increased. The required sample time will depend on how long the source needs to charge the C_{IN} capacitor and can be configured using the Sample Duration (SAMPDUR) bit field in the Control E (ADCn.CTRL E) register.

30.3.3.6 Conversion Timing

Some of the analog modules in the ADC are disabled between conversions and require time to initialize before a conversion starts. Only the modules used by the current ADC configuration are enabled, and as the initializations run in parallel, the limiting factor is the module with the slowest initialization time. The following table shows the different initialization times needed by the analog modules.

Table 30-5. ADC Initialization Timing

Analog Module	Initialization Time
ADC	10 μs ⁽¹⁾
PGA	20 μs
Settling of internal references	60 μs
Internal Tempense input	35 μs
Internal DAC input	35 μs

Note:

- If CLK_PER < 2 MHz, the ADC initialization time is 20 CLK_PER cycles.

Example: Selecting Tempense as input and using V_{DD} as the reference will give a 35 μs initialization time. Using the Tempense with the 1.024V internal reference will result in a 60 μs initialization time.

The ADC can be put in Low-Latency mode by writing a '1' to the LOWLAT bit in the Control A (ADCn.CTRLA) register. This will keep the configured modules continuously enabled, effectively removing all initialization time at the start of a conversion. The initialization time is still needed when enabling the ADC for the first time, and if reconfiguring the ADC to use an input or reference that requires initialization, as shown in the table above. The ADC Busy (ADCBUSY) bit in the Status (ADCn.STATUS) register can be used to check if initialization is ongoing.

The sampling period of the input to the ADC is configured through the Sample Duration (SAMPDUR) bit field in the Control E (ADCn.CTRL E) register as (SAMPDUR + ½) CLK_ADC cycles. The input signal characteristics affect how long the sampling period has to be.

When the PGA is used, it is sampling continuously and will only be in the Hold state when the ADC is sampling the PGA. This ADC PGA Sample Duration (ADCPGASAMPDUR) depends on f_{CLK_ADC} and is configured in the PGA Control (ADCn.PGACTRL) register. SAMPDUR will still configure the minimum sampling period of the input to the PGA as (SAMPDUR + 1) CLK_ADC cycles. In Burst mode, SAMPDUR must be ≥12, limited by the length of the Conversion state.

ATtiny3224/3226/3227

ADC - Analog-to-Digital Converter

The Series and Burst Accumulation modes can be used for oversampling to achieve up to 5 bit higher resolution, given suitable input signal and sampling frequency. Increasing the resolution by n bits can be achieved by accumulating 4^n samples and dividing the accumulated result by 2^n . The Sample Accumulation Number (SAMPNUM) bit field in the Control F (ADCn.CTRLF) register can be configured for up to $4^5 = 1024$ samples, resulting in up to 17-bit resolution.

The two tables below show the calculated conversion rates (f_{conv}) for a subset of the possible combinations of f_{CLK_ADC} and sample durations. For more details, see the relevant timing diagrams on the following pages.

Table 30-6. Example Conversion Rates (f_{conv}) for $f_{CLK_ADC} = 5$ MHz and ADCPGASAMPDUR = 20

SAMPDUR	PGA	$f_{conv}^{(1)}$ Single 8-bit [sps]	$f_{conv}^{(1)}$ Single 12-bit [sps]	f_{conv} Burst Accumulation [sps]
2	OFF	384615	294118	312500
12	OFF	217391	185185	192308
48	OFF	84746	79365	80645
255	OFF	18797	18519	18587
2	ON	149254	133333	N/A
12	ON	114943	105263	147059
48	ON	62893	59880	71429
255	ON	17452	17212	18051

Table 30-7. Example Conversion Rates (f_{conv}) for $f_{CLK_ADC} = 333$ kHz and ADCPGASAMPDUR = 6

SAMPDUR	PGA	$f_{conv}^{(1)}$ Single 8-bit [sps]	$f_{conv}^{(1)}$ Single 12-bit [sps]	f_{conv} Burst Accumulation [sps]
2	OFF	25641	19608	20833
12	OFF	14493	12346	12821
48	OFF	5650	5291	5376
255	OFF	1253	1235	1239
2	ON	17094	14184	N/A
12	ON	11299	9950	16667
48	ON	5089	4796	5952
255	ON	1223	1206	1267

Note:

- Conversion rates with the Free-Running (FREERUN) bit set to '1' in the Control F (ADCn.CTRLF) register; a new conversion will be started immediately after the results are available in the ADC.

30.3.3.6.1 Single Conversion

The figure below shows the timing diagram for the ADC when running in Single 8- or 12-bit mode without using the PGA.

Figure 30-3. Timing Diagram - Single Conversion

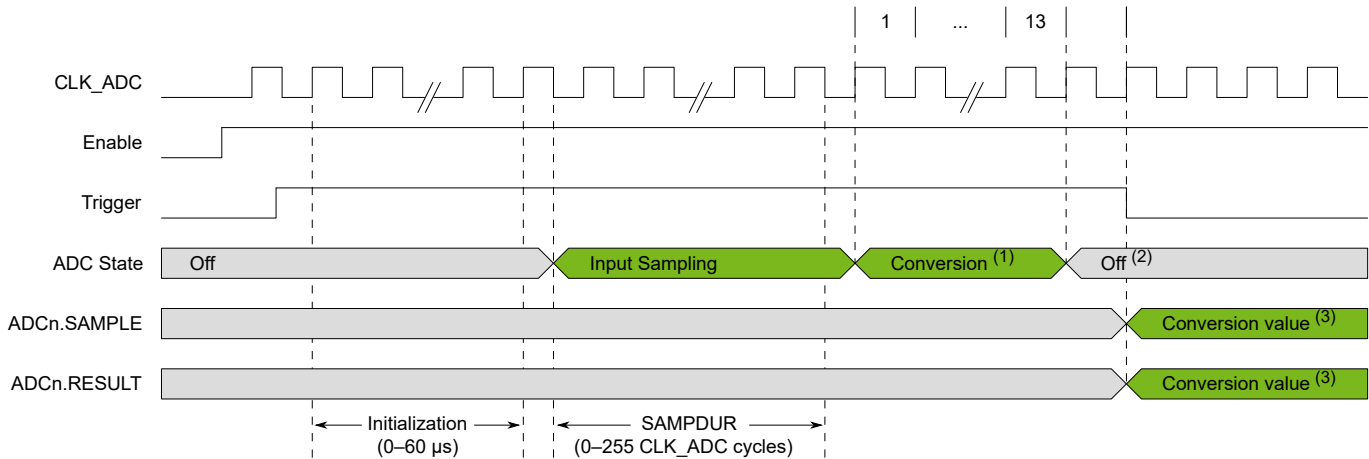

Notes:

1. In Single 8-bit mode, the length of the Conversion state is nine CLK_ADC cycles. In all other modes, it is thirteen cycles.
2. If the Low Latency (LOWLAT) bit is set to '1' in the Control A (ADCn.CTRLA) register, the analog modules in the ADC will not turn OFF at the end of the conversion, eliminating the initialization time when triggering the following conversion.
3. The time from the conversion has finished to the outputs are available in the registers is 0.5 CLK_ADC cycles followed by 1 CLK_MAIN cycle. With minimum prescaling, this sums up to 1 CLK_ADC cycle.

The total conversion time (t_{conv}) for a single result, in μs , is calculated by:

$$t_{conv} (12\text{-bit}) = t_{initialization} + \frac{SAMPDUR+15}{f_{CLK_ADC}}$$

$$t_{conv} (8\text{-bit}) = t_{initialization} + \frac{SAMPDUR+11}{f_{CLK_ADC}}$$

A new conversion starts immediately after a result is available in the Result (ADCn.RESULT) register if the Free-Running (FREERUN) bit is set to '1' in the Control F (ADCn.CTRLF) register. The Free-Running conversion rate (f_{conv}) is calculated by:

$$f_{conv} (12\text{-bit}) = \frac{f_{CLK_ADC}}{SAMPDUR+15}$$

$$f_{conv} (8\text{-bit}) = \frac{f_{CLK_ADC}}{SAMPDUR+11}$$

30.3.3.6.2 Series Accumulation

The figure below shows the timing diagram for the ADC when running in Series Accumulation mode without using the PGA.

Figure 30-4. Timing Diagram - Series Accumulation

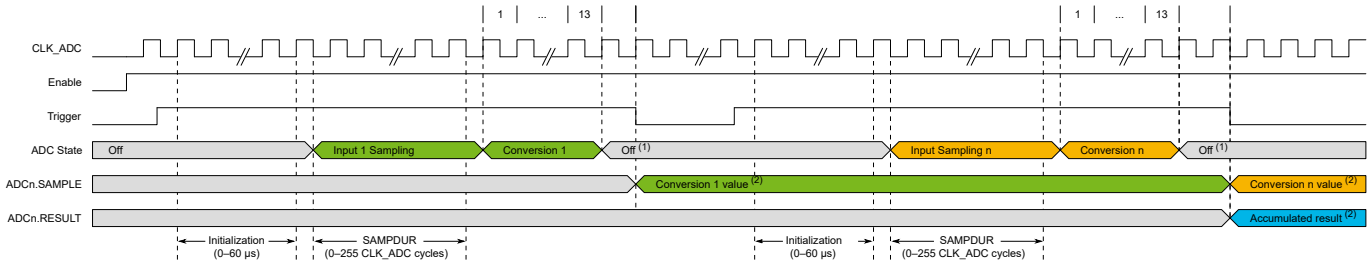

Notes:

1. If the Low Latency (LOWLAT) bit is set to '1' in the Control A (ADCn.CTRLA) register, the analog modules in the ADC will not turn OFF at the end of the conversion, eliminating the initialization time when triggering the following conversion.
2. The time from the conversion has finished to the outputs are available in the registers is 0.5 CLK_ADC cycles followed by 1 CLK_MAIN cycle. The last conversion and accumulation require an additional CLK_MAIN cycle. With minimum prescaling, this sums up to 1.5 CLK_ADC cycles before the final outputs are available.

The number of samples to accumulate is set by the Sample Number (SAMPNUM) bit field in the Control F (ADCn.CTRLF) register.

The total conversion (t_{samp}) time for each separate sample, in μs , is calculated by:

$$t_{samp} = t_{initialization} + \frac{SAMPDUR + 15}{f_{CLK_ADC}}$$

30.3.3.6.3 Burst Accumulation

The figure below shows the timing diagram for the ADC when running in Burst Accumulation mode without using the PGA.

Figure 30-5. Timing Diagram - Burst Accumulation

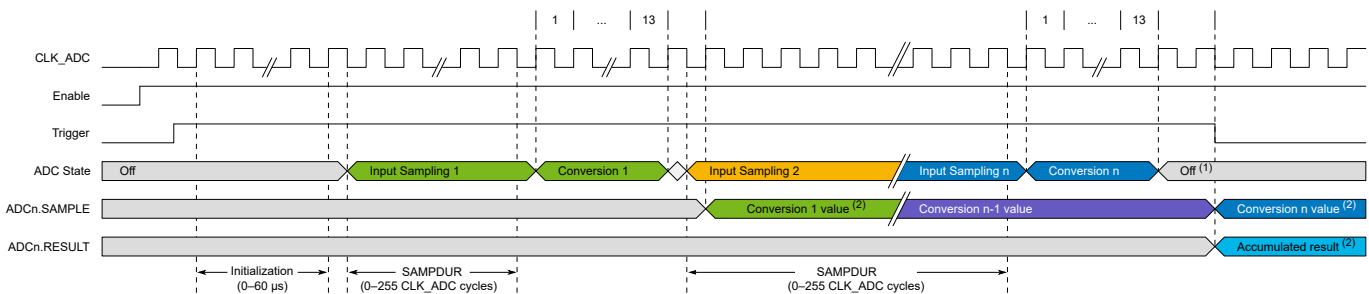

Notes:

1. If the Low Latency (LOWLAT) bit is set to '1' in the Control A (ADCn.CTRLA) register, the analog modules in the ADC will not turn OFF at the end of the conversion, eliminating the initialization time when triggering the following conversion.
2. The time from the conversion has finished to the outputs are available in the registers is 0.5 CLK_ADC cycles followed by 1 CLK_MAIN cycle. The last conversion and accumulation require an additional CLK_MAIN cycle. With minimum prescaling, this sums up to 1.5 CLK_ADC cycles before the final outputs are available.

The number of samples to accumulate is set by the Sample Number (SAMPNUM) bit field in the Control F (ADCn.CTRLF) register.

The total conversion time (t_{conv}) for a Burst Accumulation, in μs , is calculated by:

$$t_{conv} = t_{initialization} + \frac{(SAMPDUR + 14) \times SAMPNUM + 1.5}{f_{CLK_ADC}}$$

The Burst Accumulation conversion rate (f_{conv}) is calculated by:

$$f_{conv} = \frac{f_{CLK_ADC}}{SAMPDUR + 14}$$

30.3.3.6.4 Single Conversion Mode with PGA

The figure below shows the timing diagram for the ADC when running in Single 8- or 12-bit mode with the PGA.

Figure 30-6. Timing Diagram - Single Conversion with PGA

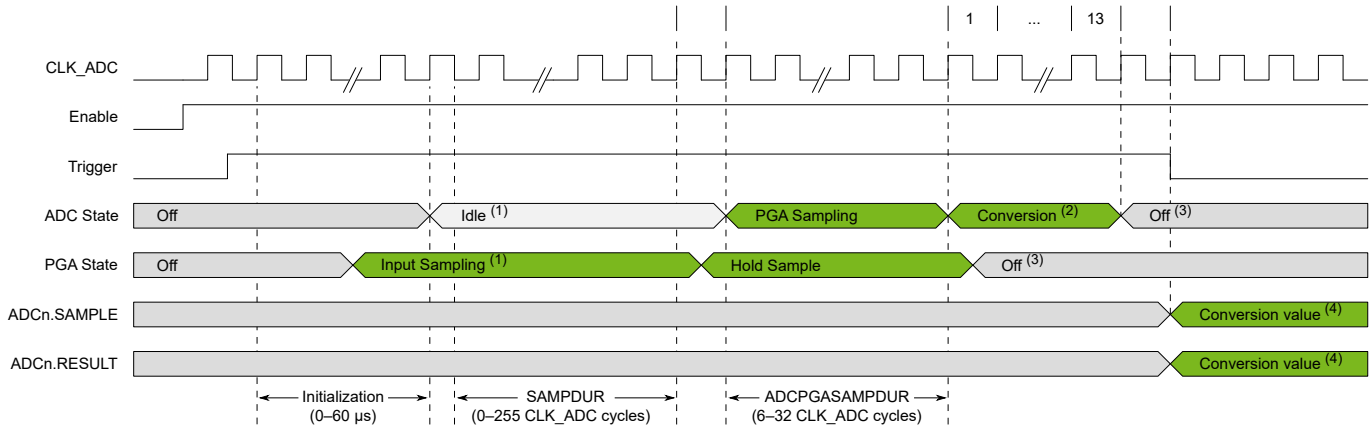

Notes:

1. The PGA will start sampling the input once the PGA initialization is done, even if the ADC initialization is still ongoing. In this case, the first sampling period will be longer than configured by SAMPDUR.
2. In Single 8-bit mode, the length of the Conversion state is nine CLK_ADC cycles. In all other modes, it is thirteen cycles.
3. If the Low Latency (LOWLAT) bit is set to '1' in the Control A (ADCn.CTRLA) register, the PGA and the analog modules in the ADC will not turn OFF at the end of the conversion, eliminating the initialization time when triggering the following conversion. The PGA will stay in the Input Sampling state until a new PGA sampling occurs.
4. The time from the conversion has finished to the outputs are available in the registers is 0.5 CLK_ADC cycles followed by 1 CLK_MAIN cycle. With minimum prescaling, this sums up to 1 CLK_ADC cycle.

The total conversion time (t_{conv}) for a single result, in µs, is calculated by:

$$t_{conv} (12\text{-bit}) = t_{initialization} + \frac{SAMPDUR + ADCPGASAMPDUR + 15.5}{f_{CLK_ADC}}$$

$$t_{conv} (8\text{-bit}) = t_{initialization} + \frac{SAMPDUR + ADCPGASAMPDUR + 11.5}{f_{CLK_ADC}}$$

A new conversion starts immediately after a result is available in the Result (ADCn.RESULT) register if the Free-Running (FREERUN) bit is set to '1' in the Control F (ADCn.CTRLF) register. The Free-Running conversion rate (f_{conv}) is calculated by:

$$f_{conv} (12\text{-bit}) = \frac{f_{CLK_ADC}}{SAMPDUR + ADCPGASAMPDUR + 15.5}$$

$$f_{conv} (8\text{-bit}) = \frac{f_{CLK_ADC}}{SAMPDUR + ADCPGASAMPDUR + 11.5}$$

30.3.3.6.5 Series Accumulation with PGA

The figure below shows the timing diagram for the ADC when running in Series Accumulation mode with the PGA.

Figure 30-7. Timing Diagram - Series Accumulation with PGA

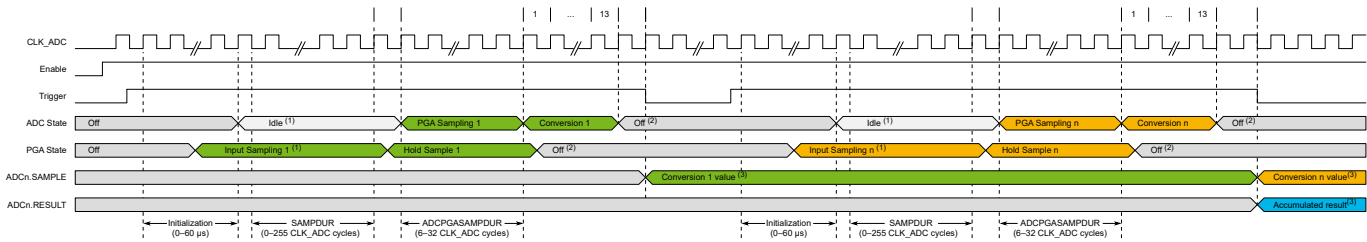

Notes:

1. The PGA will start sampling the input once the PGA initialization is done, even if the ADC initialization is still ongoing. In this case, the first sampling period will be longer than configured by SAMPDUR.
2. If the Low Latency (LOWLAT) bit is set to '1' in the Control A (ADCn.CTRLA) register, the PGA and the analog modules in the ADC will not turn OFF at the end of the conversion, eliminating the initialization time when triggering the following conversion. The PGA will stay in the Input Sampling state until a new PGA sampling occurs.
3. The time from the conversion has finished to the outputs are available in the registers is 0.5 CLK_ADC cycles followed by 1 CLK_MAIN cycle. The last conversion and accumulation require an additional CLK_MAIN cycle. With minimum prescaling, this sums up to 1.5 CLK_ADC cycles before the final outputs are available.

The number of samples to accumulate is set by the Sample Number (SAMPNUM) bit field in the Control F (ADCn.CTRLF) register.

The total conversion time (t_{samp}) for each separate sample, in μs , is calculated by:

$$t_{samp} = t_{initialization} + \frac{SAMPDUR + ADCPGASAMPDUR + 15.5}{f_{CLK_ADC}}$$

30.3.3.6.6 Burst Accumulation with PGA

The figure below shows the timing diagram for the ADC when running in Burst Accumulation mode with the PGA.

Figure 30-8. Timing Diagram - Burst Accumulation with PGA

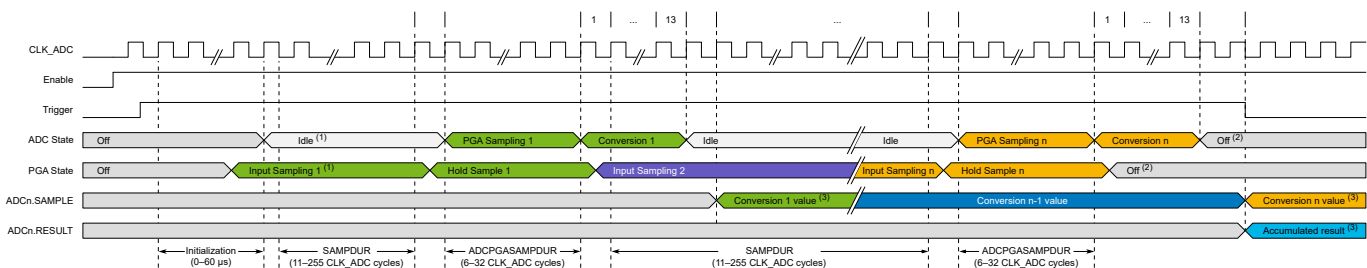

Notes:

1. The PGA will start sampling the input once the PGA initialization is done, even if the ADC initialization is still ongoing. In this case, the first sampling period will be longer than configured by SAMPDUR.
2. If the Low Latency (LOWLAT) bit is set to '1' in the Control A (ADCn.CTRLA) register, the PGA and the analog modules in the ADC will not turn OFF at the end of the conversion, eliminating the initialization time when triggering the following conversion. The PGA will stay in the Input Sampling state until a new PGA sampling occurs.
3. The time from the conversion has finished to the outputs are available in the registers is 0.5 CLK_ADC cycles followed by 1 CLK_MAIN cycle. The last conversion and accumulation require an additional CLK_MAIN cycle. With minimum prescaling, this sums up to 1.5 CLK_ADC cycles before the final outputs are available.

The number of samples to accumulate is set by the Sample Number (SAMPNUM) bit field in the Control F (ADCn.CTRLF) register.

For a Burst Accumulation with the PGA, SAMPDUR must be ≥ 11 . The total conversion time (t_{conv}), in μs , is calculated by:

$$t_{conv} = t_{initialization} + \frac{(SAMPDUR + ADCPGASAMPDUR + 2) \times SAMPNUM + 14}{f_{CLK_ADC}}$$

The burst conversion rate (f_{conv}) is calculated by:

$$f_{conv} = \frac{f_{CLK_ADC}}{SAMPDUR + ADCPGASAMPDUR + 2}$$

30.3.3.7 Temperature Measurement

An on-chip temperature sensor is available. To do a temperature measurement, follow these steps:

1. Configure the voltage reference to internal 1.024V by writing to the Reference Selection (REFSEL) bit field the ADCn.CTRLC register.
2. Select the temperature sensor as input in the Positive Input Multiplexer (ADCn.MUXPOS) register.
3. Configure the ADC Sample Duration by writing a value $\geq 32 \mu\text{s} \times f_{CLK_ADC}$ to the Sample Duration (SAMPDUR) bit field in the Control E (ADCn.CTRLE) register.
4. Acquire the temperature sensor output voltage by running a 12-bit Single-Ended conversion.
5. Process the measurement result, as described below.

The measured voltage has a linear relationship to the temperature. Due to process variations, the temperature sensor output voltage varies between the individual devices at the same temperature. The individual compensation factors determined during the production test are stored in the Signature Row:

- SIGROW.TEMPSENSE0 is a gain/slope correction
- SIGROW.TEMPSENSE1 is an offset correction

The result of the temperature sensor measurement must be processed in the application software using compensation values from device production or user calibration to achieve more accurate results. Refer to the *Electrical Characteristics* section for further details.

The following equation gives the temperature (in Kelvin):

$$T = \frac{(\text{ADC Result} - \text{Offset Correction}) \times \text{Gain Correction}}{256}$$

It is recommended to follow these steps in the user code when using the compensation values from the Signature Row:

```
int8_t sigrow_offset = SIGROW.TEMPSENSE1; // Read signed offset from signature row
uint8_t sigrow_gain = SIGROW.TEMPSENSE0; // Read unsigned gain/slope from signature row
uint16_t adc_reading = ADC0.RESULT >> 2; // 10-bit MSb of ADC result with 1.024V internal
reference

uint32_t temp = adc_reading - sigrow_offset;
temp *= sigrow_gain; // Result might overflow 16-bit variable (10-bit + 8-bit)
temp += 0x80; // Add 256/2 to get correct integer rounding on division below
temp >>= 8; // Divide result by 256 to get processed temperature in Kelvin
uint16_t temperature_in_K = temp;
```

30.3.3.8 Window Comparator

The ADC can raise the Window Comparator Interrupt (WCMP) flag in the Interrupt Flags (ADCn.INTFLAGS) register and request an interrupt (WCMP) when the output of a conversion or accumulation is above and/or below certain thresholds. The available modes are:

- The value is above a threshold
- The value is below a threshold
- The value is inside a window (above the lower threshold and below the upper threshold)
- The value is outside a window (either below the lower threshold or above the upper threshold)

The thresholds are set by writing to the Window Comparator Low and High Threshold (ADCn.WINLT and ADCn.WINHT) registers. The Window mode to use is selected by the Window Comparator mode (WINCM) bit field in the Control D (ADCn.CTRLD) register.

The Window Mode Source (WINSRC) bit in the Control D (ADCn.CTRLD) register selects if the comparison is done on the 16 LSb of the Result (ADCn.RESULT) register or the Sample (ADCn.SAMPLE) register. If an interrupt request is enabled for the WCMP flag, WINSRC selects which interrupt vector to request, RESRDY or SAMPRDY.

When accumulating multiple samples, if the Window Comparator source is the Result register, the comparison between the result and the threshold(s) will happen after the last conversion is complete. If the source is the Sample register, the comparison will happen after every conversion.

Assuming the ADC is already configured to run, follow these steps to use the Window Comparator mode:

1. Set the required threshold(s) by writing to the Window Comparator Low and High Threshold (ADCn.WINLT and ADCn.WINHT) registers.
2. Optional: Enable the interrupt request by writing a '1' to the Window Comparator Interrupt Enable (WCMP) bit in the Interrupt Control (ADCn.INTCTRL) register.
3. Enable the Window Comparator by writing the WINSRC bit field and a non-zero value to the WINCM bit field in the Control D (ADCn.CTRLD) register.

30.3.4 Events

The ADC can generate the following events:

Table 30-8. ADC Event Generators

Generator Name		Description	Event Type	Generating Clock Domain	Length of Event
Module	Event				
ADCn	RES	Result ready	Pulse	CLK_PER	One CLK_PER period
	SAMP	Sample ready			
	WCMP	Window compare match			

The conditions for generating an event are identical to those that will raise the corresponding flag in the Interrupt Flags (ADCn.INTFLAGS) register.

The ADC has one event user for detecting and acting upon input events. The table below describes the event user and the associated functionality.

Table 30-9. ADC Event Users and Available Event Actions

User Name		Description	Input Detection	Async/Sync
Peripheral	Event			
ADCn	START	ADC start on event	Edge	Async

The START event action can be triggered if the EVENT_TRIGGER setting is written to the START bit field in the Command (ADCn.COMMAND) register.

30.3.5 Interrupts

Table 30-10. Available Interrupt Vectors and Sources

Name	Vector Description	Interrupt Flag	Conditions
ERROR	Error interrupt	TRIGOVR	A new conversion is triggered while one is ongoing
		SAMPOVR	A new conversion overwrites an unread sample in ADCn.SAMPLE
		RESOVR	A new conversion or accumulation overwrites an unread result in ADCn.RESULT

.....continued			
Name	Vector Description	Interrupt Flag	Conditions
SAMPRDY	Sample Ready interrupt	SAMPRDY	The sample is available in ADCn.SAMPLE
		WCMP	As defined by WINSRC and WINCM in ADCn.CTRLD
RESRDY	Result Ready interrupt	RESRDY	The result is available in ADCn.RESULT
		WCMP	As defined by WINSRC and WINCM in ADCn.CTRLD

When an interrupt condition occurs, the corresponding interrupt flag is set in the peripheral's Interrupt Flags (*peripheral.INTFLAGS*) register.

An interrupt source is enabled or disabled by writing to the corresponding enable bit in the peripheral's Interrupt Control (*peripheral.INTCTRL*) register.

An interrupt request is generated when the corresponding interrupt source is enabled, and the interrupt flag is set. The interrupt request remains active until the interrupt flag is cleared. See the peripheral's INTFLAGS register for details on how to clear interrupt flags.

30.3.6 Sleep Mode Operation

The ADC will finish a conversion before going to Idle/Standby sleep mode. The ADC can start conversions in Idle sleep mode if the START bit field in the Command (ADCn.COMMAND) register is configured to start a conversion on an event trigger. This is also possible in Standby sleep mode if the RUNSTDBY bit is set in the Control A (ADCn.CTRLA) register.

If both the LOWLAT and RUNSTDBY bits in the Control A register are set, the ADC will keep all required modules ON during Standby sleep mode to start a conversion faster, at the expense of increased power consumption during sleep.

When the system enters POWERDOWN, the ADC will abort an ongoing conversion and enter sleep mode immediately. It is recommended to make sure conversions have completed before entering Power-Down mode.

30.3.7 Debug Operation

If the Run in Debug mode (DBGRUN) bit in the Debug Control (ADCn.DBGCTRL) register is written to '1', the ADC will continue operating when the CPU is halted in Debug mode.

If DBGRUN is '0' when the CPU is halted, an ongoing conversion will finish before the ADC halts.

30.4 Register Summary

Offset	Name	Bit Pos.	7	6	5	4	3	2	1	0
0x00	CTRLA	7:0	RUNSTDBY		LOWLAT					ENABLE
0x01	CTRLB	7:0						PRESC[3:0]		
0x02	CTRLC	7:0			TIMEBASE[4:0]				REFSEL[2:0]	
0x03	CTRLD	7:0					WINSRC	WINCM[2:0]		
0x04	INTCTRL	7:0			TRIGOVR	SAMPOVR	RESOVR	WCMP	SAMPRDY	RESRDY
0x05	INTFLAGS	7:0			TRIGOVR	SAMPOVR	RESOVR	WCMP	SAMPRDY	RESRDY
0x06	STATUS	7:0								ADCBUSY
0x07	DBGCTRL	7:0								DBGRUN
0x08	CTRLF	7:0			SAMPDUR[7:0]					
0x09	CTRLF	7:0			FREERUN	LEFTADJ		SAMPNUM[3:0]		
0x0A	COMMAND	7:0	DIFF		MODE[2:0]			START[2:0]		
0x0B	PGACTRL	7:0		GAIN[2:0]			PGABIASEL[1:0]	ADCPGASAMPDUR[1:0]	PGAEN	
0x0C	MUXPOS	7:0	VIA[1:0]				MUXPOS[5:0]			
0x0D	MUXNEG	7:0	VIA[1:0]				MUXNEG[5:0]			
0x0E ... 0x0F	Reserved									
0x10	RESULT	7:0	RESULT[7:0]							
		15:8	RESULT[15:8]							
		23:16	RESULT[23:16]							
		31:24	RESULT[31:24]							
0x14	SAMPLE	7:0	SAMPLE[7:0]							
		15:8	SAMPLE[15:8]							
0x16 ... 0x17	Reserved									
0x18	TEMP0	7:0	TEMP[7:0]							
0x19	TEMP1	7:0	TEMP[7:0]							
0x1A	TEMP2	7:0	TEMP[7:0]							
0x1B	Reserved									
0x1C	WINLT	7:0	WINLT[7:0]							
		15:8	WINLT[15:8]							
0x1E	WINHT	7:0	WINHT[7:0]							
		15:8	WINHT[15:8]							

30.5 Register Description

30.5.1 Control A

Name: CTRLA
Offset: 0x00
Reset: 0x00
Property: -

	7	6	5	4	3	2	1	0
	RUNSTDBY		LOWLAT					ENABLE
Access	R/W		R/W					R/W
Reset	0		0					0

Bit 7 – RUNSTDBY Run in Standby

This bit controls whether the ADC will run in Standby sleep mode or not.

Value	Description
0	The ADC will not run in Standby sleep mode. An ongoing conversion will finish before the ADC enters sleep mode.
1	The ADC will run in Standby sleep mode. The main clock will be requested when the ADC is triggered to perform a conversion.

Bit 5 – LOWLAT Low Latency

This bit controls whether the analog modules required by the ADC are enabled continuously or only when needed.

Value	Description
0	The ADC enables the required analog modules only when starting a conversion. This reduces the overall power consumption of the ADC and increases the initialization time when starting an ADC conversion.
1	The analog modules stay enabled when selected as input to the ADC. Using this setting will minimize the initialization time of the ADC. Note: LOWLAT does not keep the clock source enabled when the ADC is not converting, so a clock startup delay may be experienced even though LOWLAT is set. To avoid such a delay, make sure that the clock source is always enabled.

Bit 0 – ENABLE ADC Enable

This bit controls whether the ADC is enabled or not.

Value	Description
0	The ADC is disabled
1	The ADC is enabled

30.5.2 Control B

Name: CTRLB
Offset: 0x01
Reset: 0x00
Property: -

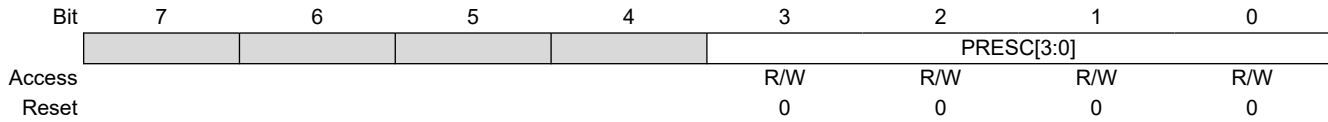

Bits 3:0 – PRESC[3:0] Prescaler

This bit field controls the division factor from the peripheral clock (CLK_PER) to the ADC clock (CLK_ADC).

Value	Name	Description
0x0	DIV2	CLK_PER divided by 2
0x1	DIV4	CLK_PER divided by 4
0x2	DIV6	CLK_PER divided by 6
0x3	DIV8	CLK_PER divided by 8
0x4	DIV10	CLK_PER divided by 10
0x5	DIV12	CLK_PER divided by 12
0x6	DIV14	CLK_PER divided by 14
0x7	DIV16	CLK_PER divided by 16
0x8	DIV20	CLK_PER divided by 20
0x9	DIV24	CLK_PER divided by 24
0xA	DIV28	CLK_PER divided by 28
0xB	DIV32	CLK_PER divided by 32
0xC	DIV40	CLK_PER divided by 40
0xD	DIV48	CLK_PER divided by 48
0xE	DIV56	CLK_PER divided by 56
0xF	DIV64	CLK_PER divided by 64

30.5.3 Control C

Name: CTRLC
Offset: 0x02
Reset: 0x00
Property: -

	Bit	7	6	5	4	3	2	1	0
		TIMEBASE[4:0]					REFSEL[2:0]		
Access		R/W	R/W	R/W	R/W	R/W	R/W	R/W	R/W
Reset		0	0	0	0	0	0	0	0

Bits 7:3 – TIMEBASE[4:0] Timebase

This bit field controls the CLK_PER cycles to get a period equal to or larger than 1 μ s. This is used for timing internal delays in the ADC before starting a conversion, such as a guard time between changing input reference or PGA gain settings.

Bits 2:0 – REFSEL[2:0] Reference Selection

This bit field controls the voltage reference for the ADC. Changing to one of the internal references will require a 60 μ s initialization time.

Value	Name	Description
0x0	VDD	V _{DD}
0x1	-	Reserved
0x2	VREFA	External reference V _{REFA}
0x3	-	Reserved
0x4	1024MV	Internal reference 1.024V
0x5	2048MV	Internal reference 2.048V
0x6	2500MV	Internal reference 2.500V
0x7	4096MV	Internal reference 4.096V

Note: The internal references can only be used if lower than V_{DD} - 0.5V.

30.5.4 Control D

Name: CTRLD
Offset: 0x03
Reset: 0x00
Property: -

	7	6	5	4	3	2	1	0
					WINSRC	WINCM[2:0]		
Access					R/W	R/W	R/W	R/W
Reset					0	0	0	0

Bit 3 – WINSRC Window Mode Source

This bit controls which source is used by the Window Comparator.

Value	Name	Description
0	RESULT	ADCn.RESULT[15:0] is used as the Window Comparator source
1	SAMPLE	ADCn.SAMPLE[15:0] is used as the Window Comparator source

Bits 2:0 – WINCM[2:0] Window Comparator Mode

This bit field controls whether the Window Comparator is enabled or not, and which thresholds will set the Window Comparator (WCMP) interrupt flag.

In the table below, OUTPUT is the 16-bit result or sample selected by WINSRC. WINLT and WINHT are the 16-bit low threshold value and the 16-bit high threshold value, respectively.

Value	Name	Description
0x0	NONE	Window Comparator disabled
0x1	BELOW	$OUTPUT < WINLT$
0x2	ABOVE	$OUTPUT > WINHT$
0x3	INSIDE	$WINLT < OUTPUT < WINHT$
0x4	OUTSIDE	$OUTPUT < WINLT$ or $OUTPUT > WINHT$
Other	-	Reserved

30.5.5 Interrupt Control

Name: INTCTRL
Offset: 0x04
Reset: 0x00
Property: -

	7	6	5	4	3	2	1	0
			TRIGOVR	SAMPOVR	RESOVR	WCMP	SAMPRDY	RESRDY
Access			R/W	R/W	R/W	R/W	R/W	R/W
Reset			0	0	0	0	0	0

Bit 5 – TRIGOVR Trigger Overrun Interrupt Enable

This bit controls whether the interrupt for a trigger overrun is enabled or not.

Value	Description
0	The Trigger Overrun interrupt is disabled
1	The Trigger Overrun interrupt is enabled

Bit 4 – SAMPOVR Sample Overwrite Interrupt Enable

This bit controls whether the interrupt for a sample overwrite is enabled or not.

Value	Description
0	The Sample Overwrite interrupt is disabled
1	The Sample Overwrite interrupt is enabled

Bit 3 – RESOVR Result Overwrite Interrupt Enable

This bit controls whether the interrupt for a result overwrite is enabled or not.

Value	Description
0	The Result Overwrite interrupt is disabled
1	The Result Overwrite interrupt is enabled

Bit 2 – WCMP Window Comparator Interrupt Enable

This bit controls whether the interrupt for the Window Comparator is enabled or not.

Value	Description
0	The Window Comparator interrupt is disabled
1	The Window Comparator interrupt is enabled

Bit 1 – SAMPRDY Sample Ready Interrupt Enable

This bit controls whether the Sample Ready interrupt is enabled or not.

Value	Description
0	The Sample Ready interrupt is disabled
1	The Sample Ready interrupt is enabled

Bit 0 – RESRDY Result Ready Interrupt Enable

This bit controls whether the Result Ready interrupt is enabled or not.

Value	Description
0	The Result Ready interrupt is disabled
1	The Result Ready interrupt is enabled

30.5.6 Interrupt Flags

Name: INTFLAGS
Offset: 0x05
Reset: 0x00
Property: -

	7	6	5	4	3	2	1	0
Access			R/W	R/W	R/W	R/W	R/W	R/W
Reset			0	0	0	0	0	0

Bit 5 – TRIGOVR Trigger Overrun Interrupt Flag

This flag is cleared by writing a '1' to it.

This flag is set when a start trigger is received while a conversion is ongoing.

Writing a '0' to this bit has no effect.

Writing a '1' to this bit will clear the Trigger Overrun interrupt flag.

Bit 4 – SAMPOVR Sample Overwrite Interrupt Flag

This flag is cleared by writing a '1' to it.

This flag is set when an unread sample is overwritten in the Sample (ADCn.SAMPLE) register.

Writing a '0' to this bit has no effect.

Writing a '1' to this bit will clear the Sample Overwrite interrupt flag.

Bit 3 – RESOVR Result Overwrite Interrupt Flag

This flag is cleared by writing a '1' to it.

This flag is set when an unread result is overwritten in the Result (ADCn.RESULT) register.

Writing a '0' to this bit has no effect.

Writing a '1' to this bit will clear the Result Overwrite interrupt flag.

Bit 2 – WCMP Window Comparator Interrupt Flag

This flag is cleared by writing a '1' to it.

This flag is set when the conversion or accumulation is complete, and the thresholds match the selected window comparator source and mode, as set by WINSRC and WINCM in the Control D (ADCn.CTRLD) register.

Writing a '0' to this bit has no effect.

Writing a '1' to this bit will clear the Window Comparator interrupt flag.

Bit 1 – SAMPRDY Sample Ready Interrupt Flag

This flag is cleared by writing a '1' to it or by reading the Sample (ADCn.SAMPLE) register.

This flag is set when a conversion is complete, and a new sample is ready.

Writing a '0' to this bit has no effect.

Writing a '1' to this bit will clear the Sample Ready interrupt flag.

Bit 0 – RESRDY Result Ready Interrupt Flag

This flag is cleared by writing a '1' to it or by reading the Result (ADCn.RESULT) register.

This flag is set when a conversion or accumulation is complete, and a new result is ready.

Writing a '0' to this bit has no effect.

Writing a '1' to this bit will clear the Result Ready interrupt flag.

ATtiny3224/3226/3227

ADC - Analog-to-Digital Converter

30.5.7 Status

Name: STATUS
Offset: 0x06
Reset: 0x00
Property: -

Bit	7	6	5	4	3	2	1	0
Access								R
Reset								0

Bit 0 – ADCBUSY ADC Busy

This bit is cleared when an ADC conversion is complete, and settling times related to configuration changes are finished.

This bit is set when the ADC is doing a conversion or waiting for settling times related to configuration changes.

30.5.8 Debug Control

Name: DBGCTRL
Offset: 0x07
Reset: 0x00
Property: -

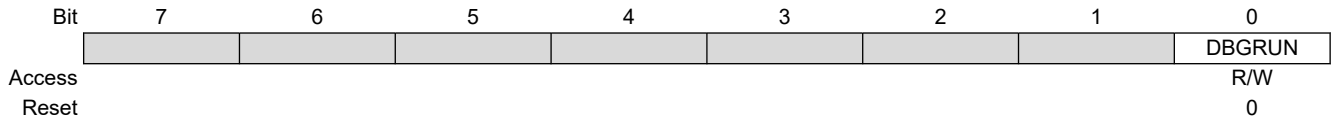

Bit 0 – DBGRUN Run in Debug Mode

This bit controls whether the ADC will continue operation or not when in Debug mode and the CPU is halted.

Value	Description
0	The ADC will not continue operating in Debug mode when the CPU is halted. An ongoing conversion or burst accumulation will finish before the ADC stops.
1	The ADC will continue operating in Debug mode when the CPU is halted

30.5.9 Control E

Name: CTRL E
Offset: 0x08
Reset: 0x00
Property: -

Bit	7	6	5	4	3	2	1	0
	SAMPDUR[7:0]							
Access	R/W	R/W	R/W	R/W	R/W	R/W	R/W	R/W
Reset	0	0	0	0	0	0	0	0

Bits 7:0 – SAMPDUR[7:0] Sample Duration

This bit field controls the input sample duration in ADC clock (CLK_ADC) cycles. The sample duration without the PGA is (SAMPDUR + ½) CLK_ADC cycles.

If the PGA is used, the input sample duration is (SAMPDUR + 1) CLK_ADC cycles, while the ADC PGA Sample Duration (ADCPGASAMPDUR) bit field in the PGA Control (ADCn.PGACTRL) register controls how long the ADC will sample the PGA.

30.5.10 Control F

Name: CTRLF
Offset: 0x09
Reset: 0x00
Property: -

	7	6	5	4	3	2	1	0
			FREERUN	LEFTADJ		SAMPNUM[3:0]		
Access			R/W	R/W	R/W	R/W	R/W	R/W
Reset			0	0	0	0	0	0

Bit 5 – FREERUN Free-Running

This bit controls whether the ADC Free-Running mode is enabled or not.

Value	Description
0	The ADC Free-Running mode is disabled
1	The ADC Free-Running mode is enabled. A new conversion is started as soon as the previous conversion or accumulation has completed.

Note: Free-Running mode is not supported in Series mode.

Bit 4 – LEFTADJ Left Adjust

This bit controls whether the ADC output is left adjusted or not.

Value	Description
0	The ADC output left adjustment is disabled
1	The ADC output left adjustment is enabled

Bits 3:0 – SAMPNUM[3:0] Sample Accumulation Number Select

This bit field controls the number of consecutive ADC samples that are accumulated automatically into the ADC Result (ADCn.RESULT) register. The most recent sample will be available in the ADC Sample (ADCn.SAMPLE) register.

Value	Name	Description
0x0	NONE	No accumulation, single sample per conversion result
0x1	ACC2	2 samples accumulated
0x2	ACC4	4 samples accumulated
0x3	ACC8	8 samples accumulated
0x4	ACC16	16 samples accumulated
0x5	ACC32	32 samples accumulated
0x6	ACC64	64 samples accumulated
0x7	ACC128	128 samples accumulated
0x8	ACC256	256 samples accumulated
0x9	ACC512	512 samples accumulated
0xA	ACC1024	1024 samples accumulated
Other	-	Reserved

30.5.11 Command

Name: COMMAND
Offset: 0x0A
Reset: 0x00
Property: -

	Bit	7	6	5	4	3	2	1	0
		DIFF		MODE[2:0]				START[2:0]	
Access		R/W	R/W	R/W	R/W		R/W	R/W	R/W
Reset		0	0	0	0		0	0	0

Bit 7 – DIFF Differential

This bit controls whether the ADC conversion is Single-Ended or Differential.

Value	Description
0x0	Unsigned Single-Ended conversion. Only the ADCn.MUXPOS register is used.
0x1	Signed Differential conversion. Both the ADCn.MUXPOS and ADCn.MUXNEG registers are used.

Bits 6:4 – MODE[2:0] Mode

This bit field controls the conversion mode for the ADC. Switching from one of the accumulation modes to a Single mode will reset the accumulator.

Value	Name	Description
0x0	SINGLE_8BIT	Single conversion with 8-bit resolution
0x1	SINGLE_12BIT	Single conversion with 12-bit resolution
0x2	SERIES	Series with accumulation, separate trigger for every 12-bit conversion
0x3	SERIES_SCALING	Series with accumulation and scaling, separate trigger for every 12-bit conversion
0x4	BURST	Burst with accumulation, one trigger will run SAMPNUM 12-bit conversions in one sequence
0x5	BURST_SCALING	Burst with accumulation and scaling, one trigger will run SAMPNUM 12-bit conversions in one sequence
Other	-	Reserved

Bits 2:0 – START[2:0] Start Conversion

This bit field starts or stops an ADC conversion, or controls how an ADC conversion will start.

Value	Name	Description
0x0	STOP	Stop an ongoing conversion
0x1	IMMEDIATE	Start a conversion immediately. This will be set back to STOP when the conversion is done, unless Free-Running mode is enabled.
0x2	MUXPOS_WRITE	Start when a write to the MUXPOS register is done
0x3	MUXNEG_WRITE	Start when a write to the MUXNEG register is done
0x4	EVENT_TRIGGER	Start when an event is received by the ADC
Other	-	Reserved

Note: If the ENABLE bit in ADCn.CTRLA is '0' when writing the START bit field to IMMEDIATE, it will automatically be set to STOP.

30.5.12 PGA Control

Name: PGACTRL
Offset: 0x0B
Reset: 0x04
Property: -

	7	6	5	4	3	2	1	0
	GAIN[2:0]			PGABIASSEL[1:0]		ADCPGASAMPDUR[1:0]		PGAEN
Access	R/W	R/W	R/W	R/W	R/W	R/W	R/W	R/W
Reset	0	0	0	0	0	1	0	0

Bits 7:5 – GAIN[2:0] GAIN

This bit field controls the gain setting for the PGA.

Value	Name	Description
0x0	1X	1x gain
0x1	2X	2x gain
0x2	4X	4x gain
0x3	8X	8x gain
0x4	16X	16x gain
Other	-	Reserved

Bits 4:3 – PGABIASSEL[1:0] PGA Bias Select

This bit field controls the bias current supplied to the PGA.

Value	Name	Description
0x0	1X	100% BIAS current. Usable for $f_{CLK_ADC} \leq 6$ MHz.
0x1	3_4X	75% BIAS current. Usable for $f_{CLK_ADC} \leq 4$ MHz.
0x2	1_2X	50% BIAS current. Usable for $f_{CLK_ADC} \leq 2.5$ MHz.
0x3	1_4X	25% BIAS current. Usable for $f_{CLK_ADC} \leq 1.25$ MHz.

Bits 2:1 – ADCPGASAMPDUR[1:0] ADC PGA Sample Duration

This bit field controls the sampling duration for the ADC to sample the PGA output.

Value	Name	Description
0x0	6CLK	6 CLK_ADC cycles. Usable for $f_{CLK_ADC} \leq 1.25$ MHz.
0x1	15CLK	15 CLK_ADC cycles. Usable for $f_{CLK_ADC} \leq 5$ MHz.
0x2	20CLK	20 CLK_ADC cycles. Usable for $f_{CLK_ADC} \leq 6$ MHz.
0x3	-	Reserved

Bit 0 – PGAEN PGA Enable

This bit controls whether the PGA is enabled or not when selected by the VIA bit field in the Input Multiplexer (ADCn.MUXPOS or ADCn.MUXNEG) registers.

Value	Description
0	The PGA is disabled
1	The PGA is enabled

Note: If both PGAEN and the Low Latency (LOWLAT) bit in the Control A (ADCn.CTRLA) register are '1', the PGA will be ON continuously, even when not selected by the VIA bit field. This eliminates the initialization time if reconfiguring the ADC to use the PGA.

30.5.13 Positive Input Multiplexer

Name: MUXPOS
Offset: 0x0C
Reset: 0x00
Property: -

	7	6	5	4	3	2	1	0
	VIA[1:0]		MUXPOS[5:0]					
Access	R/W	R/W	R/W	R/W	R/W	R/W	R/W	R/W
Reset	0	0	0	0	0	0	0	0

Bits 7:6 – VIA[1:0]

This bit field controls how the analog input is connected to the ADC input.

Value	Name	Description
0x0	DIRECT	Input connected directly to the ADC
0x1	PGA	Input connected to the ADC via the PGA
Other	-	Reserved

Note: The VIA bits in MUXPOS and MUXNEG are shared, so a value written to the VIA bit field in one of the two registers is updated in both. It is, therefore, not possible to have one input using the PGA and the other not using the PGA.

Bits 5:0 – MUXPOS[5:0] Positive Input Multiplexer

This bit field controls which analog input is connected to the positive input of the ADC/PGA. Changing this setting may require some settling time. Refer to the *Electrical Characteristics* section for further details.

Value	Name	Description
0x00	DEFAULT	Internal ground
0x01–0x0F	AIN1-AIN15	ADC input pin 1-15
0x30	GND	Internal ground
0x31	VDDDIV10	VDD divided by 10
0x32	TEMPSENSE	Temperature sensor
0x33	DACREF0	DACREF from AC0
Other	-	Reserved

30.5.14 Negative Input Multiplexer

Name: MUXNEG
Offset: 0x0D
Reset: 0x00
Property: -

	7	6	5	4	3	2	1	0
	VIA[1:0]		MUXNEG[5:0]					
Access	R/W	R/W	R/W	R/W	R/W	R/W	R/W	R/W
Reset	0	0	0	0	0	0	0	0

Bits 7:6 – VIA[1:0]

This bit field controls how the analog input is connected to the ADC input.

Value	Name	Description
0x0	DIRECT	Input connected directly to the ADC
0x1	PGA	Input connected to the ADC via the PGA
Other	-	Reserved

Note: The VIA bits in MUXPOS and MUXNEG are shared, so a value written to the VIA bit field in one of the two registers is updated in both. It is, therefore, not possible to have one input using the PGA and the other not using the PGA.

Bits 5:0 – MUXNEG[5:0] Negative Input Multiplexer

This bit field controls which analog input is connected to the negative input of the ADC/PGA. Changing this setting may require some settling time. Refer to the *Electrical Characteristics* section for further details.

Value	Name	Description
0x00	DEFAULT	Internal ground
0x01–0x07	AIN1-AIN7	ADC input pin 1-7
0x30	GND	Internal ground
0x31	VDDDIV10	Divided VDD
0x33	DACREF0	DACREF from AC0
Other	-	Reserved

30.5.15 Result

Name: RESULT
Offset: 0x10
Reset: 0x00
Property: -

The ADCn.RESULT0 to ADCn.RESULT3 registers represent the 32-bit value, ADCn.RESULT. The low byte [7:0] (suffix 0) is accessible at the original offset. The n higher bytes [31:8] can be accessed at offset + n.

Refer to the *Output Formats* section for details on the output from this register.

Bit	31	30	29	28	27	26	25	24
	RESULT[31:24]							
Access	R	R	R	R	R	R	R	R
Reset	0	0	0	0	0	0	0	0
Bit	23	22	21	20	19	18	17	16
	RESULT[23:16]							
Access	R	R	R	R	R	R	R	R
Reset	0	0	0	0	0	0	0	0
Bit	15	14	13	12	11	10	9	8
	RESULT[15:8]							
Access	R	R	R	R	R	R	R	R
Reset	0	0	0	0	0	0	0	0
Bit	7	6	5	4	3	2	1	0
	RESULT[7:0]							
Access	R	R	R	R	R	R	R	R
Reset	0	0	0	0	0	0	0	0

Bits 31:24 – RESULT[31:24] Result byte 3
This bit field constitutes the MSB of the ADCn.RESULT register.

Bits 23:16 – RESULT[23:16] Result byte 2
This bit field constitutes the third byte of the ADCn.RESULT register.

Bits 15:8 – RESULT[15:8] Result byte 1
This bit field constitutes the second byte of the ADCn.RESULT register.

Bits 7:0 – RESULT[7:0] Result byte 0
This bit field constitutes the LSB of the ADCn.RESULT register.

30.5.16 Sample

Name: SAMPLE
Offset: 0x14
Reset: 0x00
Property: -

The ADCn.SAMPLEL and ADCn.SAMPLEH register pair represents the 16-bit value, ADCn.SAMPLE. The low byte [7:0] (suffix L) is accessible at the original offset. The high byte [15:8] (suffix H) can be accessed at offset + 0x01.

Refer to the *Output Formats* section for details on the output from this register.

	Bit	15	14	13	12	11	10	9	8
		SAMPLE[15:8]							
Access		R	R	R	R	R	R	R	R
Reset		0	0	0	0	0	0	0	0
	Bit	7	6	5	4	3	2	1	0
		SAMPLE[7:0]							
Access		R	R	R	R	R	R	R	R
Reset		0	0	0	0	0	0	0	0

Bits 15:8 – SAMPLE[15:8] Sample high byte
 This bit field constitutes the MSB of the 16-bit register.

Bits 7:0 – SAMPLE[7:0] Sample low byte
 This bit field constitutes the LSB of the 16-bit register.

30.5.17 Temporary n

Name: TEMPn
Offset: 0x18 + n*0x01 [n=0..2]
Reset: 0x00
Property: -

The Temporary registers are used by the CPU for single-cycle access to the 16- and 32-bit registers of this peripheral. The registers are common for all the 16- and 32-bit registers of this peripheral and can be read and written by software. For more details on reading and writing 16- and 32-bit registers, refer to *Accessing 16-Bit Registers* and *Accessing 32-Bit Registers* in the *AVR CPU* section.

Bit	7	6	5	4	3	2	1	0
	TEMP[7:0]							
Access	R/W	R/W	R/W	R/W	R/W	R/W	R/W	R/W
Reset	0	0	0	0	0	0	0	0

Bits 7:0 – TEMP[7:0] Temporary
 Temporary bit field for read/write operations in 16- and 32-bit registers.

30.5.18 Window Comparator Low Threshold

Name: WINLT
Offset: 0x1C
Reset: 0x00
Property: -

This register is the 16-bit Low Threshold for the digital comparator monitoring the ADC Result or Sample (ADCn.RESULT or ADCn.SAMPLE) registers. The data format must be according to Conversion mode and left adjustment setting.

The ADCn.WINLTH and ADCn.WINLTL register pair represents the 16-bit value, ADCn.WINLT. The low byte [7:0] (suffix L) is accessible at the original offset. The high byte [15:8] (suffix H) can be accessed at offset + 0x01.

When monitoring the ADC Result register, in an accumulation mode, the window comparator thresholds are applied to the result after all accumulation and, optionally, scaling is done.

	Bit	15	14	13	12	11	10	9	8
		WINLT[15:8]							
Access		R/W	R/W	R/W	R/W	R/W	R/W	R/W	R/W
Reset		0	0	0	0	0	0	0	0
	Bit	7	6	5	4	3	2	1	0
		WINLT[7:0]							
Access		R/W	R/W	R/W	R/W	R/W	R/W	R/W	R/W
Reset		0	0	0	0	0	0	0	0

Bits 15:8 – WINLT[15:8] Window Comparator Low Threshold high byte
 This bit field holds the MSB of the 16-bit register.

Bits 7:0 – WINLT[7:0] Window Comparator Low Threshold low byte
 This bit field holds the LSB of the 16-bit register.

30.5.19 Window Comparator High Threshold

Name: WINHT
Offset: 0x1E
Reset: 0x00
Property: -

This register is the 16-bit High Threshold for the digital comparator monitoring the ADC Result or Sample (ADCn.RESULT or ADCn.SAMPLE) registers. The data format must be according to Conversion mode and left adjustment setting.

The ADCn.WINHTH and ADCn.WINHTL register pair represents the 16-bit value, ADCn.WINHT. The low byte [7:0] (suffix L) is accessible at the original offset. The high byte [15:8] (suffix H) can be accessed at offset + 0x01.

When monitoring the ADC Result register, in an accumulation mode, the window comparator thresholds are applied to the result after all accumulation and, optionally, scaling is done.

	Bit	15	14	13	12	11	10	9	8
		WINHT[15:8]							
Access		R/W	R/W	R/W	R/W	R/W	R/W	R/W	R/W
Reset		0	0	0	0	0	0	0	0
	Bit	7	6	5	4	3	2	1	0
		WINHT[7:0]							
Access		R/W	R/W	R/W	R/W	R/W	R/W	R/W	R/W
Reset		0	0	0	0	0	0	0	0

Bits 15:8 – WINHT[15:8] Window Comparator High Threshold high byte
 This bit field holds the MSB of the 16-bit register.

Bits 7:0 – WINHT[7:0] Window Comparator High Threshold low byte
 This bit field holds the LSB of the 16-bit register.

31. UPDI - Unified Program and Debug Interface

31.1 Features

- UPDI One-Wire Interface for External Programming and On-Chip-Debugging (OCD)
 - Enable programming by high-voltage or fuse
 - Uses the `RESET` pin of the device for programming
 - No GPIO pins occupied during the operation
 - Asynchronous half-duplex UART protocol towards the programmer
- Programming:
 - Built-in error detection and error signature generation
 - Override of response generation for faster programming
- Debugging:
 - Memory-mapped access to device address space (NVM, RAM, I/O)
 - No limitation on the device clock frequency
 - Unlimited number of user program breakpoints
 - Two hardware breakpoints
 - Support for advanced OCD features
 - Run-time readout of the CPU Program Counter (PC), Stack Pointer (SP) and Status Register (SREG) for code profiling
 - Detection and signalization of the Break/Stop condition in the CPU
 - Program flow control for Run, Stop and Reset debug instructions
 - Nonintrusive run-time chip monitoring without accessing the system registers
 - Interface for reading the result of the CRC check of the Flash on a locked device

31.2 Overview

The Unified Program and Debug Interface (UPDI) is a proprietary interface for external programming and OCD of a device.

The UPDI supports programming of Nonvolatile Memory (NVM) space, Flash, EEPROM, fuses, lock bits, and the user row. Some memory-mapped registers are accessible only with the correct access privilege enabled (key, lock bits) and only in the OCD Stopped mode or certain Programming modes. These modes are unlocked by sending the correct key to the UPDI. See the *NVMCTRL - Nonvolatile Memory Controller* section for programming via the NVM controller and executing NVM controller commands.

The UPDI is partitioned into three separate protocol layers: the UPDI Physical (PHY) Layer, the UPDI Data Link (DL) Layer and the UPDI Access (ACC) Layer. The default PHY layer handles bidirectional UART communication over the UPDI pin line towards a connected programmer/debugger and provides data recovery and clock recovery on an incoming data frame in the One-Wire Communication mode. Received instructions and corresponding data are handled by the DL layer, which sets up the communication with the ACC layer based on the decoded instruction. Access to the system bus and memory-mapped registers is granted through the ACC layer.

Programming and debugging are done through the PHY layer, which is a one-wire UART based on a half-duplex interface using the `RESET` pin for data reception and transmission. The clocking of the PHY layer is done by a dedicated internal oscillator.

The ACC layer is the interface between the UPDI and the connected bus matrix. This layer grants access via the UPDI interface to the bus matrix with memory-mapped access to system blocks such as memories, NVM, and peripherals.

The Asynchronous System Interface (ASI) provides direct interface access to select features in the OCD, NVM, and System Management systems. This gives the debugger direct access to system information without requesting bus access.

31.2.1 Block Diagram

Figure 31-1. UPDI Block Diagram

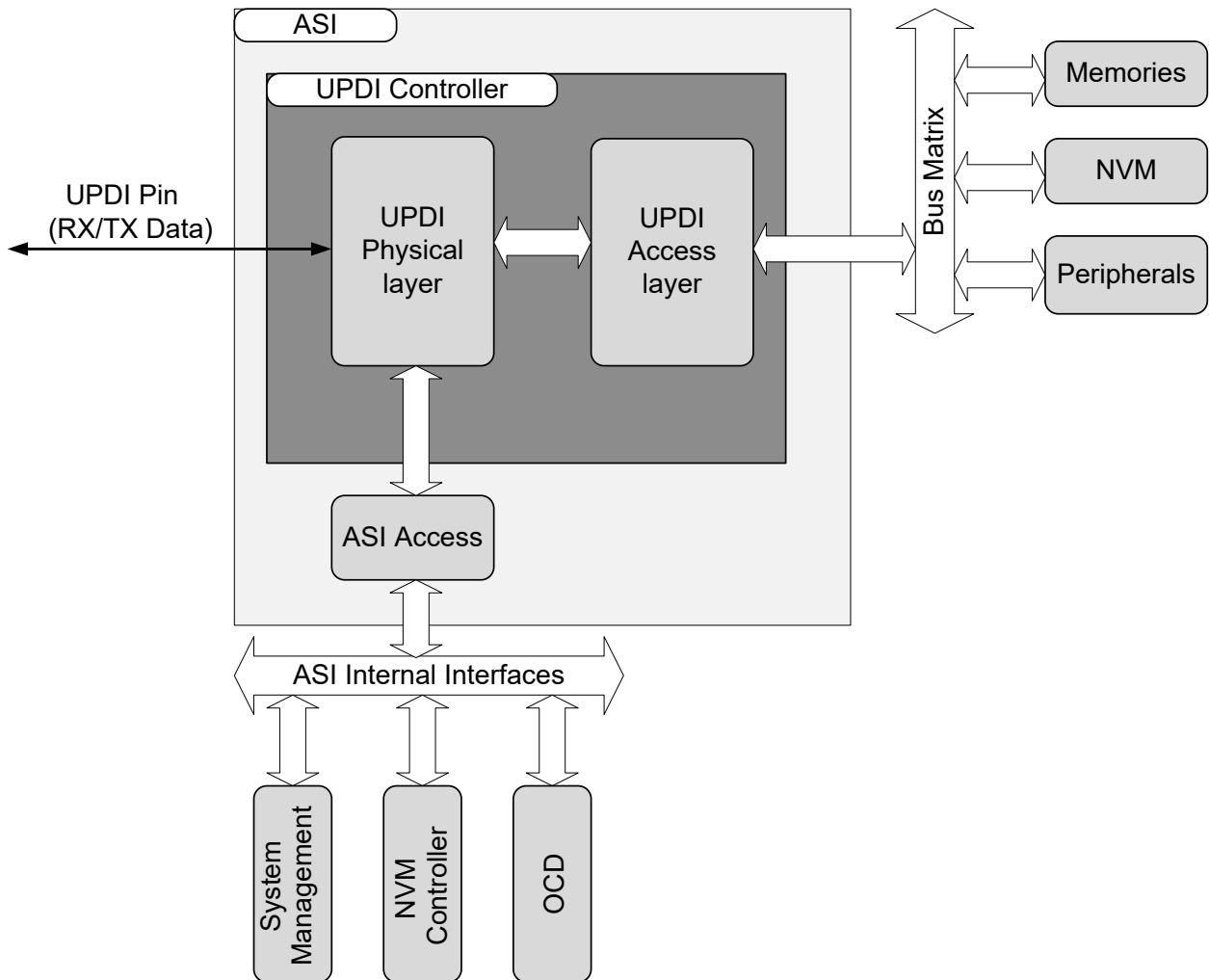

31.2.2 Clocks

The PHY layer and the ACC layer can operate on different clock domains. The PHY layer clock is derived from the dedicated internal oscillator, and the ACC layer clock is the same as the peripheral clock. There is a synchronization boundary between the PHY and the ACC layer, which ensures correct operation between the clock domains. The UPDI clock output frequency is selected through the ASI, and the default UPDI clock start-up frequency is 4 MHz after enabling or resetting the UPDI. The UPDI clock frequency can be changed by writing to the UPDI Clock Divider Select (UPDICKSEL) bit field in the ASI Control A (UPDI.ASI_CTRLA) register.

Figure 31-2. UPDI Clock Domains

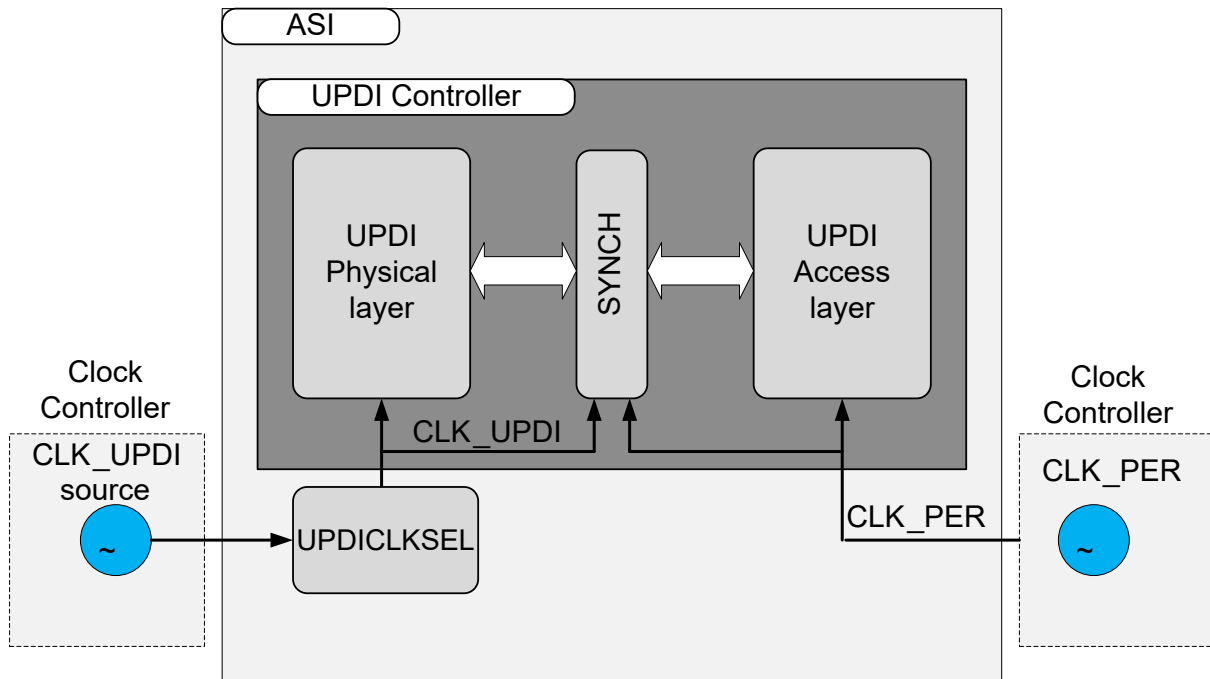

31.2.3 Physical Layer

The PHY layer is the communication interface between a connected programmer/debugger and the device. The main features of the PHY layer can be summarized as follows:

- Support for UPDI One-Wire mode, using asynchronous, half-duplex UART communication on the UPDI pin
- Internal baud detection, clock and data recovery on the UART frame
- Error detection (parity, clock recovery, frame, system errors)
- Transmission response generation (ACK)
- Generation of error signatures during operation
- Guard time control

31.2.4 I/O Lines and Connections

To operate the UPDI, the $\overline{\text{RESET}}$ pin must be set to UPDI mode. This is not done through the port I/O pin configuration as regular I/O pins but through setting the $\overline{\text{RESET}}$ Pin Configuration (RSTPINCFG) bits in FUSE.SYSCFG0, as described in [UPDI Enable with Fuse Override of RESET Pin](#), or by following the UPDI high-voltage enable sequence from [UPDI Enable with High-Voltage Override of RESET Pin](#). Pull enable, input enable, and output enable settings are automatically controlled by the UPDI when active.

31.3 Functional Description

31.3.1 Principle of Operation

The communication through the UPDI is based on standard UART communication, using a fixed frame format, and automatic baud rate detection for clock and data recovery. In addition to the data frame, several control frames are important to the communication: DATA, IDLE, BREAK, SYNCH, ACK.

Figure 31-3. Supported UPDI Frame Formats

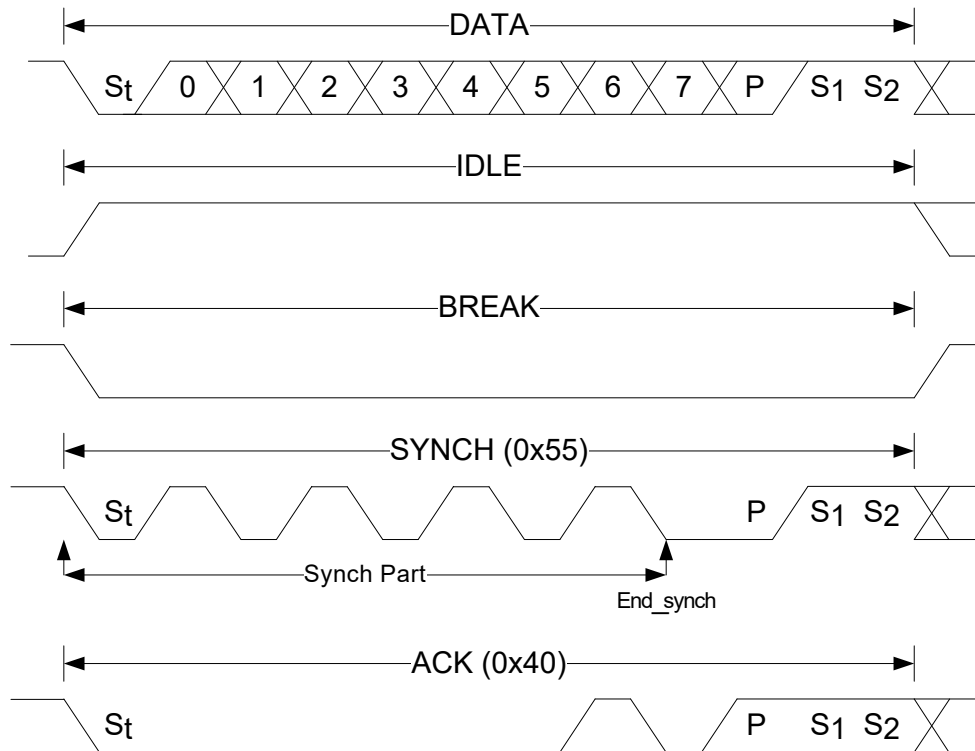

Frame	Description
DATA	A DATA frame consists of one Start (St) bit, which is always low, eight Data bits, one Parity (P) bit for even parity, and two Stop (S1 and S2) bits, which are always high. If the Parity bit or Stop bits have an incorrect value, an error will be detected and signaled by the UPDI. The parity bit-check in the UPDI can be disabled by writing to the Parity Disable (PARD) bit in the Control A (UPDI.CTRLA) register, in which case the parity generation from the debugger is ignored.
IDLE	This is a special frame that consists of at least 12 high bits. This is the same as keeping the transmission line in an Idle state.
BREAK	This is a special frame that consists of at least 12 low bits. It is used to reset the UPDI back to its default state and is typically used for error recovery.
SYNCH	The SYNCH frame is used by the Baud Rate Generator to set the baud rate for the coming transmission. A SYNCH character is always expected by the UPDI in front of every new instruction, and after a successful BREAK has been transmitted.
ACK	The ACK frame is transmitted from the UPDI whenever an ST or an STS instruction has successfully crossed the synchronization boundary and gained bus access. When an ACK is received by the debugger, the next transmission can start.

31.3.1.1 UPDI UART

The communication is initiated from the debugger/programmer side. Every transmission must start with a SYNCH character, which the UPDI can use to recover the transmission baud rate and store this setting for the incoming data. The baud rate set by the SYNCH character will be used for both reception and transmission of the subsequent instruction and data bytes. See the *UPDI Instruction Set* section for details on when the next SYNCH character is expected in the instruction stream.

There is no writable Baud Rate register in the UPDI, so the baud rate sampled from the SYNCH character is used for data recovery when sampling the data byte.

The transmission baud rate of the PHY layer is related to the selected UPDI clock, which can be adjusted by writing to the UPDI Clock Divider Select (UPDICKSEL) bit field in the ASI Control A (UPDI.ASI_CTRLA) register. The receive and transmit baud rates are always the same within the accuracy of the auto-baud.

Table 31-1. Recommended UART Baud Rate Based on UPDICKSEL Setting

UPDICKSEL[1:0]	Max. Recommended Baud Rate	Min. Recommended Baud Rate
0x1 (16 MHz)	0.9 Mbps	0.300 kbps
0x2 (8 MHz)	450 kbps	0.150 kbps
0x3 (4 MHz) - Default	225 kbps	0.075 kbps

The UPDI Baud Rate Generator utilizes fractional baud counting to minimize the transmission error. With the fixed frame format used by the UPDI, the maximum and recommended receiver transmission error limits can be seen in [Table 31-2](#).

Table 31-2. Receiver Baud Rate Error

Data + Parity Bits	R _{slow}	R _{fast}	Max. Total Error [%]	Recommended Max. RX Error [%]
9	96.39	104.76	+4.76/-3.61	+1.5/-1.5

31.3.1.2 BREAK Character

The BREAK character is used to reset the internal state of the UPDI to the default setting. This is useful if the UPDI enters an Error state due to a communication error or when the synchronization between the debugger and the UPDI is lost.

To ensure that a BREAK is successfully received by the UPDI in all cases, the debugger must send two consecutive BREAK characters. The first BREAK will be detected if the UPDI is in Idle state and will not be detected if it is sent while the UPDI is receiving or transmitting (at a very low baud rate). However, this will cause a frame error for the reception (RX) or a contention error for the transmission (TX), and abort the ongoing operation. The UPDI will then detect the next BREAK successfully.

Upon receiving a BREAK, the UPDI oscillator setting in the ASI Control A (UPDI.ASI_CTRLA) register is reset to the 4 MHz default UPDI clock selection. This changes the baud rate range of the UPDI, according to [Table 31-1](#).

31.3.1.2.1 BREAK in One-Wire Mode

In One-Wire mode, the programmer/debugger and UPDI can be totally out of synch, requiring a worst-case length for the BREAK character to be sure that the UPDI can detect it. Assuming the slowest UPDI clock speed of 4 MHz (250 ns), the maximum length of the 8-bit SYNCH pattern value that can be contained in 16 bits is $65535 \times 250 \text{ ns} = 16.4 \text{ ms/byte} = 16.4 \text{ ms}/8 \text{ bits} = 2.05 \text{ ms/bit}$.

This gives a worst-case BREAK frame duration of $2.05 \text{ ms} \times 12 \text{ bits} \approx 24.6 \text{ ms}$

for the slowest prescaler setting. When the prescaler setting is known, the time of the BREAK frame can be relaxed according to the values from [Table 31-3](#).

Table 31-3. Recommended BREAK Character Duration

UPDICKSEL[1:0]	Recommended BREAK Character Duration
0x1 (16 MHz)	6.15 ms
0x2 (8 MHz)	12.30 ms
0x3 (4 MHz)	24.60 ms

31.3.1.3 SYNCH Character

The SYNCH character has eight bits and follows the regular UPDI frame format. It has a fixed value of 0x55. The SYNCH character has two main purposes:

1. It acts as the enabling character for the UPDI after a disable.

2. It is used by the Baud Rate Generator to set the baud rate for the subsequent transmission. If an invalid SYNCH character is sent, the next transmission will not be sampled correctly.

31.3.1.3.1 SYNCH in One-Wire Mode

The SYNCH character is used before each new instruction. When using the REPEAT instruction, the SYNCH character is expected only before the first instruction after REPEAT.

The SYNCH is a known character which, through its property of toggling for each bit, allows the UPDI to measure how many UPDI clock cycles are needed to sample the 8-bit SYNCH pattern. The information obtained through the sampling is used to provide Asynchronous Clock Recovery and Asynchronous Data Recovery on reception, and to keep the baud rate of the connected programmer when doing transmit operations.

31.3.2 Operation

The UPDI must be enabled before the UART communication can start.

31.3.2.1 UPDI Enabling

The enable sequence for the UPDI is device independent and is described in the following paragraphs.

31.3.2.1.1 One-Wire Enable

The UPDI pin has an internal pull-up resistor, and by driving the UPDI pin low for more than 200 ns, a connected programmer will initiate the start-up sequence.

The negative edge transition will cause an edge detector (located in the high-voltage domain if it is in a Multi-Voltage System) to start driving the UPDI pin low, so when the programmer releases the line, it will stay low until the requested UPDI oscillator is ready. The expected arrival time for the clock will depend on the oscillator implementation regarding the accuracy, overshoot, and readout of the oscillator calibration. For a Multi-Voltage System, the line will be driven low until the regulator is at the correct level, and the system is powered up with the selected oscillator ready and stable. The programmer must poll the UPDI pin after releasing it the first time to detect when the pin transitions to high again. This transition means that the edge detector has released the pin (pull-up), and the UPDI can receive a SYNCH character. Upon successful detection of the SYNCH character, the UPDI is enabled and will prepare for the reception of the first instruction.

The enable transmission sequence is shown in the next figure, where the active driving periods for the programmer and edge detector are included. The “UPDI pin” waveform shows the pin value at any given time.

The delay given for the edge detector active drive period is a typical start-up time waiting for 256 cycles on a 32 MHz oscillator + the calibration readout. Refer to the *Electrical Characteristics* section for details on the expected start-up times.

Note: The first instruction issued after the initial enable SYNCH does not need an extra SYNCH to be sent because the enable sequence SYNCH sets up the Baud Rate Generator for the first instruction.

To avoid the UPDI from staying enabled if an accidental trigger of the edge detector happens, the UPDI will automatically disable itself and lower its clock request. See [31.3.2.2.1. Disable During Start-up](#) for more details.

UPDI Enable with Fuse Override of RESET Pin

When the $\overline{\text{RESET}}$ Pin Configuration (RSTPINCFG) bit in FUSE.SYSCFG0 is 0x1, the $\overline{\text{RESET}}$ pin will be overridden, and the UPDI will take control of the pin and configure it as an input with pull-up.

When the pull-up is detected, the debugger initiates the enable sequence by driving the line low for a duration of t_{Deb0} , as depicted in [Figure 31-4](#):

Figure 31-4. UPDI Enable Sequence with UPDI PAD Enabled By Fuse

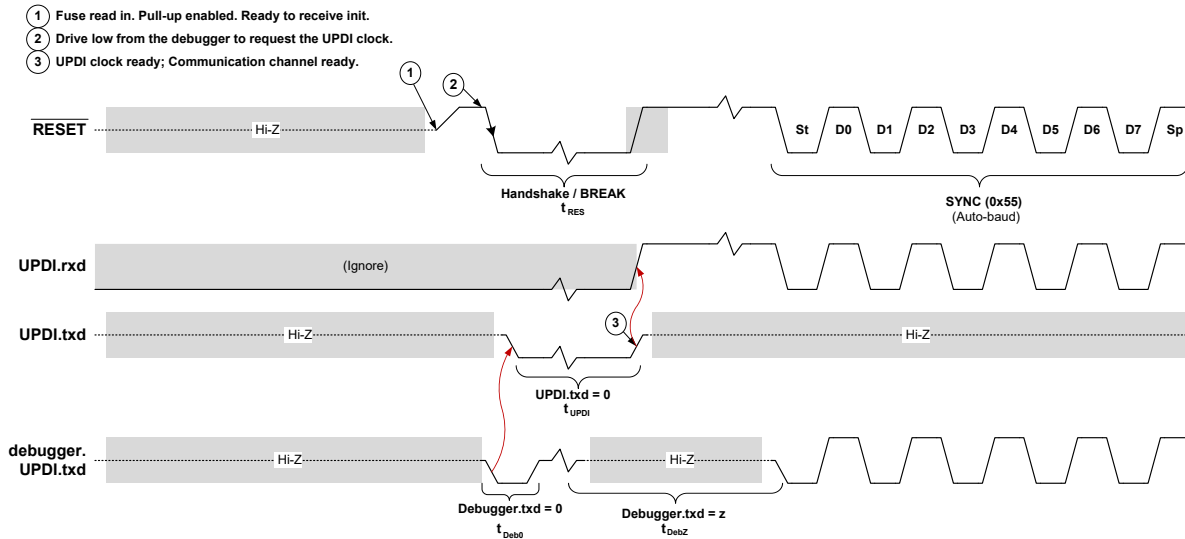

When the negative edge is detected, the UPDI clock starts. The UPDI will continue to drive the line low until the clock is stable and ready for the UPDI to use. The duration of t_{UPDI} will vary, depending on the status of the oscillator when the UPDI is enabled. After this duration, the data line will be released by the UPDI and pulled high.

When the debugger detects that the line is high, the initial SYNCH character 0×55 must be transmitted to synchronize the UPDI communication data rate. If the Start bit of the SYNCH character is not sent within maximum t_{DebZ} , the UPDI will disable itself, and the UPDI enabling sequence must be reinitiated. If the timing is violated, the UPDI is disabled to avoid unintentional enabling of the UPDI.

After a successful SYNCH character transmission, the first instruction frame can be transmitted.

UPDI Enable with High-Voltage Override of \overline{RESET} Pin

GPIO or Reset functionality on the \overline{RESET} pin can be overridden by the UPDI by using high-voltage (HV) programming. Applying an HV pulse to the \overline{RESET} pin will switch the pin functionality to UPDI. This is independent of the \overline{RESET} Pin Configuration (RSTPINCFG) in FUSE.SYSCFG0. Follow these steps to override the pin functionality:

1. **Recommended:** Reset the device before starting the HV enable sequence.
2. Apply the HV signal, as described in [Figure 31-5](#).
3. Send the NVMPROG key using the `key` instruction after the first SYNC character to start programming. Locked devices will only accept the CHIPERASE key. See also section *Chip Erase*.
4. After the programming is finished, reset the UPDI by writing the UPDI Disable (UPDIDIS) bit in the Control B (UPDI.CTRLB) register to '1' using the `STCS` instruction.

During power-up, the \overline{RESET} signal must be released before the HV pulse can be applied. The duration of the pulse is recommended in the range from 100 μ s to 1 ms before tri-stating.

When applying the rising edge of the HV pulse, the UPDI will be reset. After tri-stating, the UPDI will remain in Reset until the \overline{RESET} pin is driven low by the debugger. This will release the UPDI Reset and initiate the same enable sequence, as explained in [UPDI Enable with Fuse Override of \$\overline{RESET}\$ Pin](#).

Figure 31-5. UPDI Enable Sequence by High-Voltage (HV) Programming

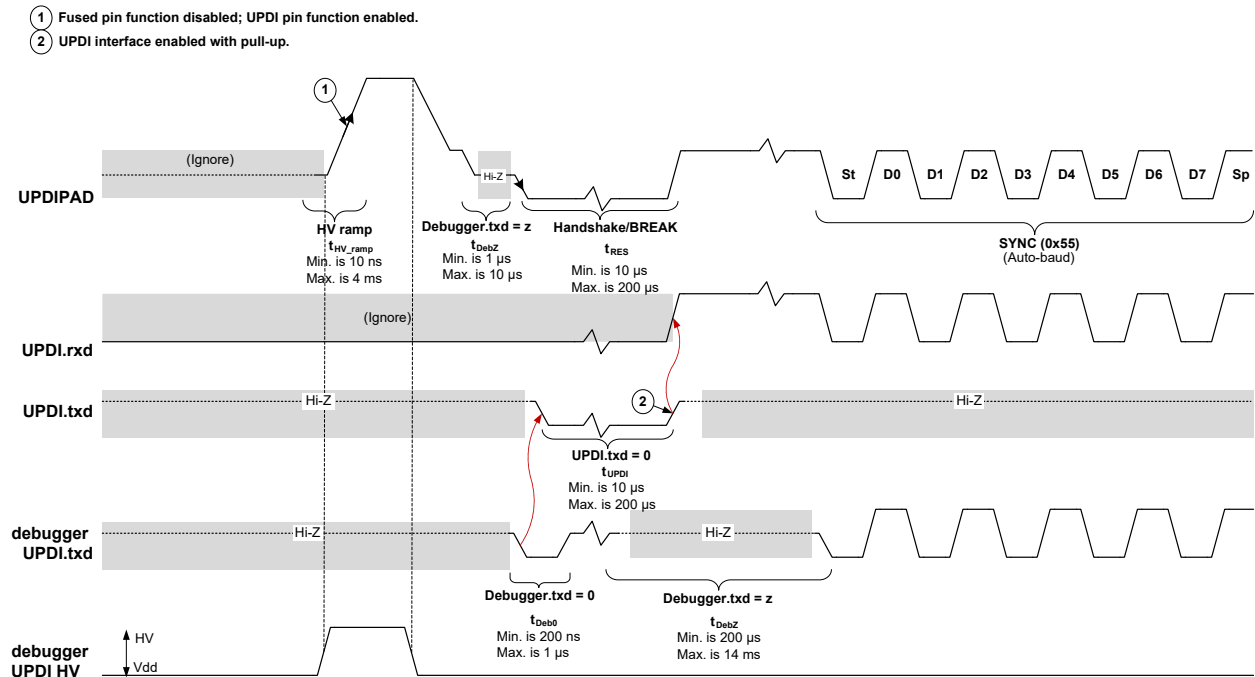

When enabled by an HV pulse, only a POR will disable the UPDI configuration on the $\overline{\text{RESET}}$ pin and restore the default setting. If issuing a UPDI Disable command through the UPDIDIS bit in UPDI.CTRLB, the UPDI will be reset, and the clock request will be canceled, but the $\overline{\text{RESET}}$ pin will remain in UPDI configuration.

Notes:

1. If insufficient external protection is added to the UPDI pin, an ESD pulse can be interpreted by the device as a high-voltage override and enable the UPDI.
2. The actual threshold voltage for the UPDI HV activation depends on V_{DD} . See the *Electrical Characteristics* section for more details.

Output Enable Timer Protection for GPIO Configuration

When the RESET Pin Configuration (RSTPINCFG) bit in FUSE.SYSCFG0 is '0x0', the $\overline{\text{RESET}}$ pin is configured as GPIO. To avoid a potential conflict between the GPIO actively driving the output and a UPDI high-voltage (HV) enable sequence initiation, the GPIO output driver is disabled for a minimum of 8.8 ms after a System Reset.

It is always recommended to issue a Power-On Reset (POR) before entering the HV programming sequence.

31.3.2.2 UPDI Disabling

31.3.2.2.1 Disable During Start-up

During the enable sequence, the UPDI can disable itself in case of an invalid enable sequence. There are two mechanisms implemented to reset any requests the UPDI has given to the Power Management and set the UPDI to the disabled state. A new enable sequence must then be initiated to enable the UPDI.

Time-Out Disable

When the start-up negative edge detector releases the pin after the UPDI has received its clock, or when the regulator is stable and the system has power in a Multi-Voltage system, the default pull-up drives the UPDI pin high. If the programmer does not detect that the pin is high, and does not initiate a transmission of the SYNCH character within 16.4 ms at 4 MHz UPDI clock after the UPDI has released the pin, the UPDI will disable itself.

Note: Start-up oscillator frequency is device-dependent. The UPDI will count for 65536 cycles on the UPDI clock before issuing the time-out.

Incorrect SYNCH pattern

An incorrect SYNCH pattern is detected if the length of the SYNCH character is longer than the number of samples that can be contained in the UPDI Baud Rate register (overflow), or shorter than the minimum fractional count that can be handled for the sampling length of each bit. If any of these errors are detected, the UPDI will disable itself.

31.3.2.2.2 UPDI Regular Disable

Any programming or debugging session that does not require any specific operation from the UPDI after disconnecting the programmer has to be terminated by writing the UPDI Disable (UPDIDIS) bit in the Control B (UPDI.CTRLB) register, upon which the UPDI will issue a System Reset and disable itself. The Reset will restore the CPU to the Run state, independent of the previous state. It will also lower the UPDI clock request to the system and reset any UPDI KEYS and settings.

If the disable operation is not performed, the UPDI and the oscillator's request will remain enabled. This causes increased power consumption for the application.

31.3.2.3 UPDI Communication Error Handling

The UPDI contains a comprehensive error detection system that provides information to the debugger when recovering from an error scenario. The error detection consists of detecting physical transmission errors like parity error, contention error, and frame error, to more high-level errors like access time-out error. See the UPDI Error Signature (PESIG) bit field in the Status B (UPDI.STATUSB) register for an overview of the available error signatures.

Whenever the UPDI detects an error, it will immediately enter an internal Error state to avoid unwanted system communication. In the Error state, the UPDI will ignore all incoming data requests, except when a BREAK character is received. The following procedure must always be applied when recovering from an Error condition.

1. Send a BREAK character. See section *BREAK Character* for recommended BREAK character handling.
2. Send a SYNCH character at the desired baud rate for the next data transfer.
3. Execute a Load Control Status (LDCS) instruction to read the UPDI Error Signature (PESIG) bit field in the Status B (UPDI.STATUSB) register and get the information about the occurred error.
4. The UPDI has now recovered from the Error state and is ready to receive the next SYNCH character and instruction.

31.3.2.4 Direction Change

To ensure correct timing for a half-duplex UART operation, the UPDI has a built-in guard time mechanism to relax the timing when changing direction from RX to TX mode. The guard time is represented by Idle bits inserted before the next Start bit of the first response byte is transmitted. The number of Idle bits can be configured through the Guard Time Value (GTVAL) bit field in the Control A (UPDI.CTRLA) register. The duration of each Idle bit is given by the baud rate used by the current transmission.

Figure 31-6. UPDI Direction Change by Inserting Idle Bits

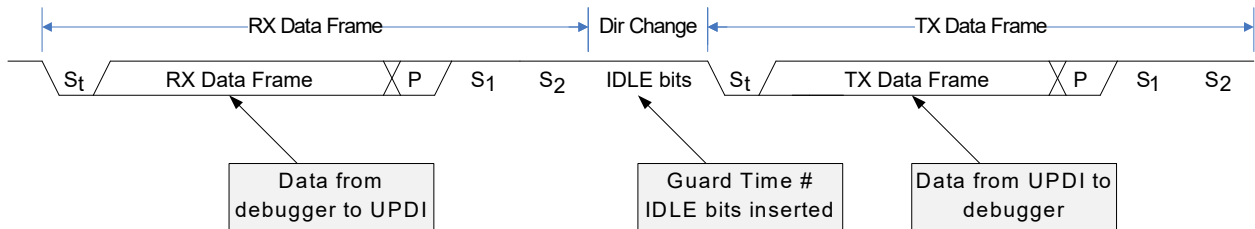

The UPDI guard time is the minimum Idle time that the connected debugger will experience when waiting for data from the UPDI. The maximum Idle time is the same as time-out. The Idle time before a transmission will be more than the expected guard time when the synchronization time plus the data bus accessing time is longer than the guard time.

It is recommended to always use the insertion of minimum two Guard Time bits on the UPDI side, and one guard time cycle insertion from the debugger side.

31.3.3 UPDI Instruction Set

The communication through the UPDI is based on a small instruction set. These instructions are part of the UPDI Data Link (DL) layer. The instructions are used to access the UPDI registers, since they are mapped into an internal memory space called "ASI Control and Status (CS) space", as well as the memory-mapped system space. All instructions are byte instructions and must be preceded by a SYNCH character to determine the baud rate for the communication. See section *UPDI UART* for information about setting the baud rate for the transmission. The following figure gives an overview of the UPDI instruction set.

Figure 31-7. UPDI Instruction Set Overview

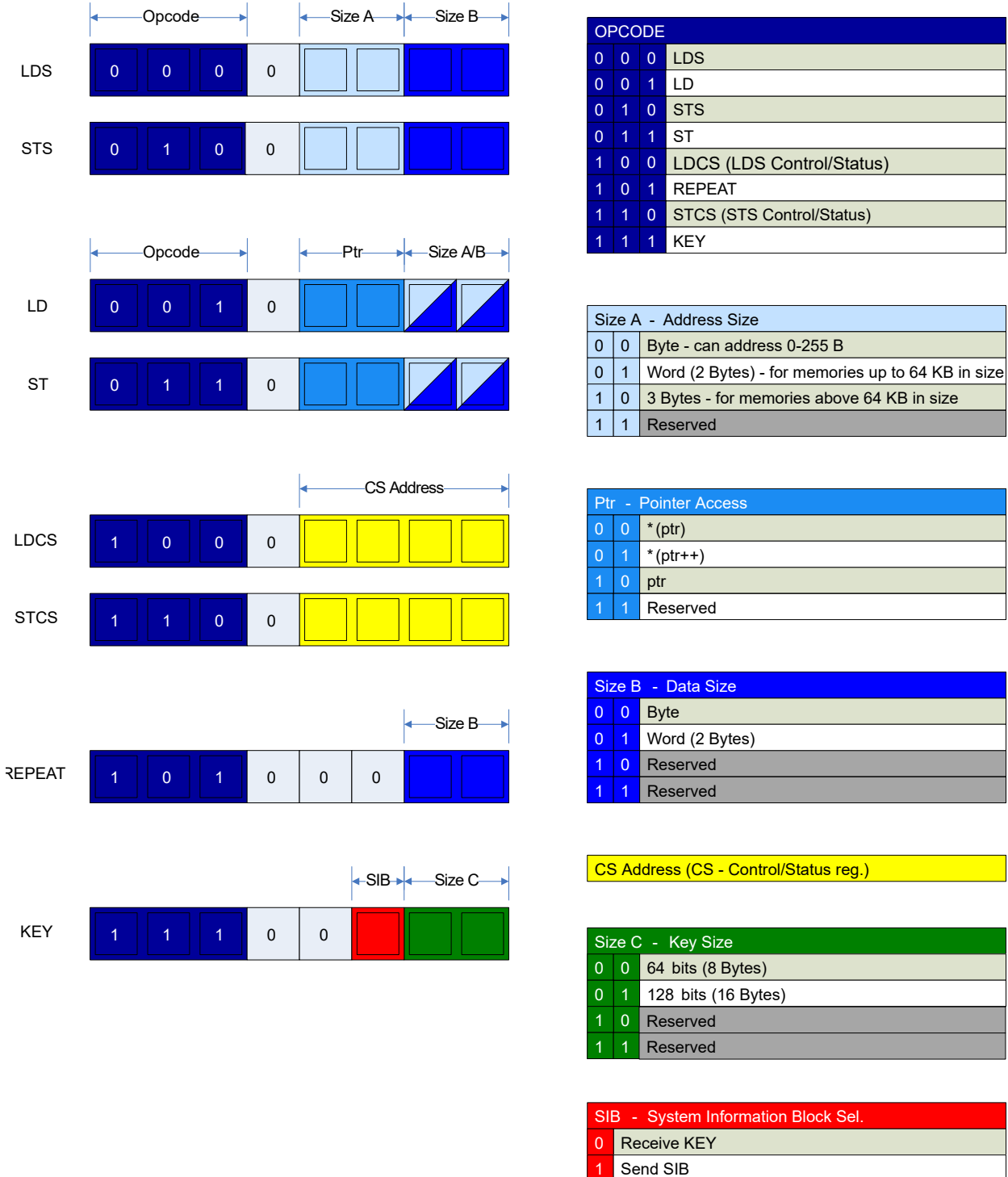

31.3.3.1 LDS - Load Data from Data Space Using Direct Addressing

The **LDS** instruction is used to load data from the system bus into the PHY layer shift register for serial readout. The **LDS** instruction is based on direct addressing, and the address must be given as an operand to the instruction for the

data transfer to start. The maximum supported size for the address and data is 32 bits. The `LDS` instruction supports repeated memory access when combined with the `REPEAT` instruction.

After issuing the `LDS` instruction, the number of desired address bytes, as indicated by the Size A field followed by the output data size, which is selected by the Size B field, must be transmitted. The output data is issued after the specified Guard Time (GT). When combined with the `REPEAT` instruction, the address must be sent in for each iteration of the repeat, meaning after each time the output data sampling is done. There is no automatic address increment when using `REPEAT` with `LDS`, as it uses a direct addressing protocol.

Figure 31-8. LDS Instruction Operation

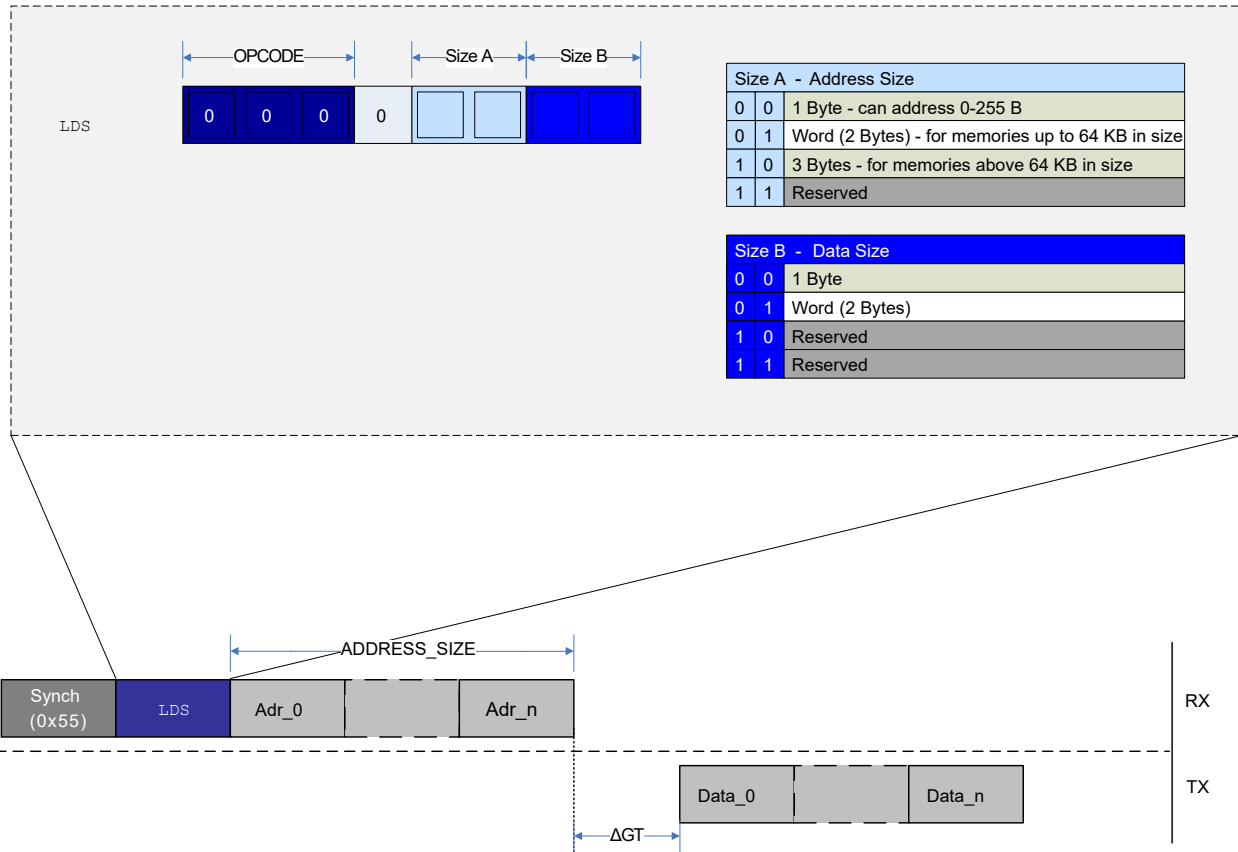

When the instruction is decoded, and the address byte(s) are received as dictated by the decoded instruction, the DL layer will synchronize all required information to the ACC layer, which will handle the bus request and synchronize data buffered from the bus back again to the DL layer. This will create a synchronization delay that must be taken into consideration upon receiving the data from the UPDI.

31.3.3.2 STS - Store Data to Data Space Using Direct Addressing

The `STS` instruction is used to store data that are shifted serially into the PHY layer shift register to the system bus address space. The `STS` instruction is based on direct addressing, and the address must be given as an operand to the instruction for the data transfer to start. The address is the first set of operands, and data are the second set. The size of the address and data operands are given by the size fields presented in [Figure 31-9](#). The maximum size for both address and data is 32 bits.

The `STS` supports repeated memory access when combined with the `REPEAT` instruction.

Figure 31-9. STS Instruction Operation

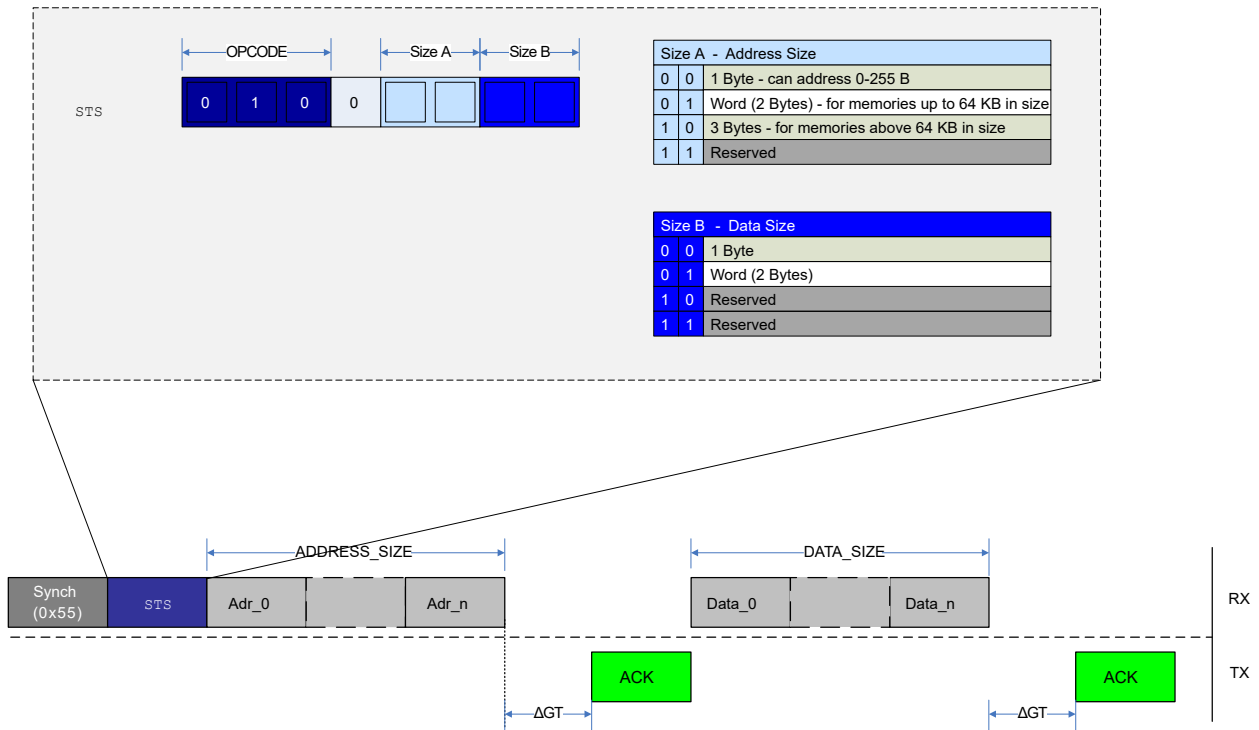

The transfer protocol for an *STS* instruction is depicted in Figure 31-9, following this sequence:

1. The address is sent.
2. An Acknowledge (ACK) is sent back from the UPDI if the transfer was successful.
3. The number of bytes, as specified in the *STS* instruction, is sent.
4. A new ACK is received after the data have been successfully transferred.

31.3.3.3 LD - Load Data from Data Space Using Indirect Addressing

The *LD* instruction is used to load data from the data space and into the PHY layer shift register for serial readout. The *LD* instruction is based on indirect addressing, which means that the Address Pointer in the UPDI needs to be written before the data space read access. Automatic pointer post-increment operation is supported and is useful when the *LD* instruction is utilized with the *REPEAT* instruction. It is also possible to do an *LD* from the UPDI Pointer register. The maximum supported size for address and data load is 32 bits.

Figure 31-10. LD Instruction Operation

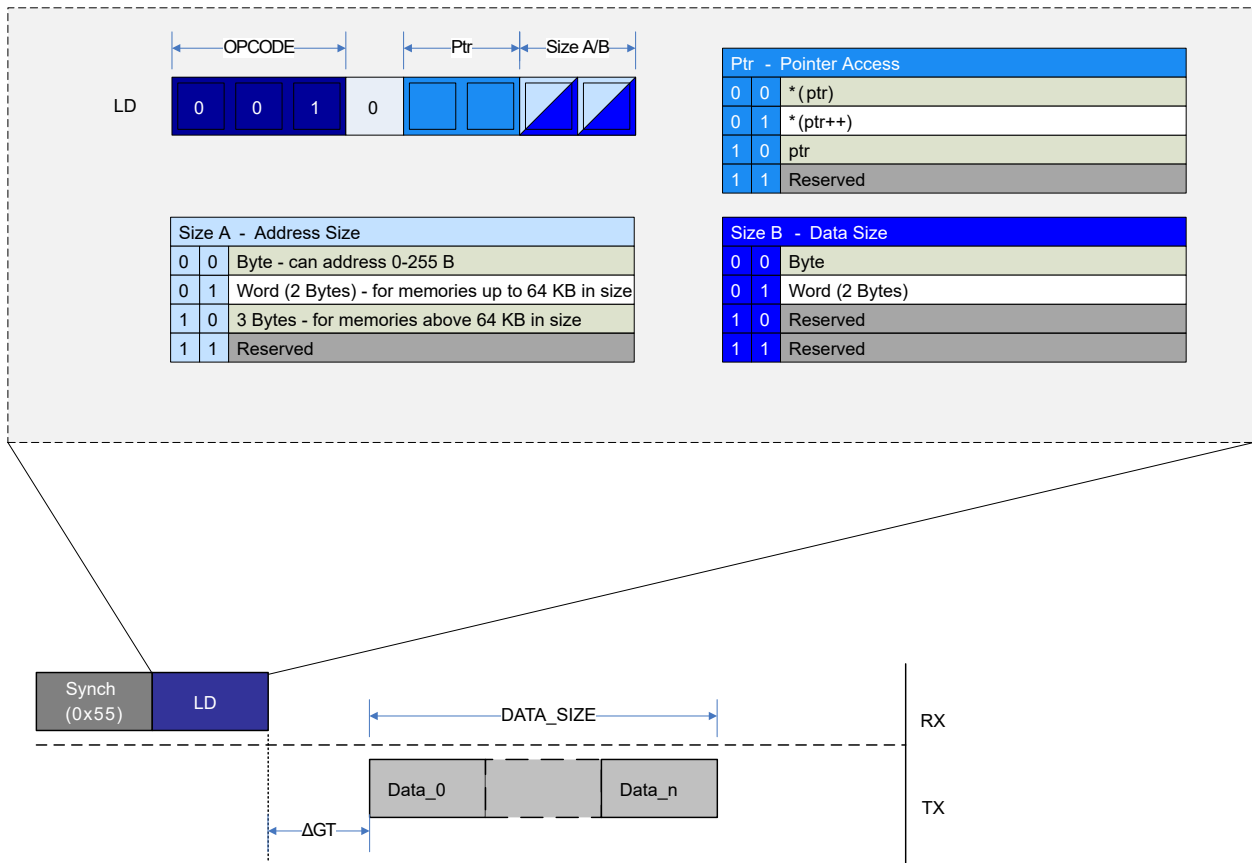

The figure above shows an example of a typical LD sequence, where the data are received after the Guard Time (GT) period. Loading data from the UPDI Pointer register follows the same transmission protocol.

For the LD instruction from the data space, the pointer register must be set up by using an ST instruction to the UPDI Pointer register. After the ACK has been received on a successful Pointer register write, the LD instruction must be set up with the desired DATA SIZE operands. An LD to the UPDI Pointer register is done directly with the LD instruction.

31.3.3.4 ST - Store Data from UPDI to Data Space Using Indirect Addressing

The ST instruction is used to store data from the UPDI PHY shift register to the data space. The ST instruction is used to store data that are shifted serially into the PHY layer. The ST instruction is based on indirect addressing, which means that the Address Pointer in the UPDI needs to be written before the data space. The automatic pointer post-increment operation is supported and is useful when the ST instruction is utilized with the REPEAT instruction. The ST instruction is also used to store the UPDI Address Pointer into the Pointer register. The maximum supported size for storing address and data is 32 bits.

Figure 31-11. ST Instruction Operation

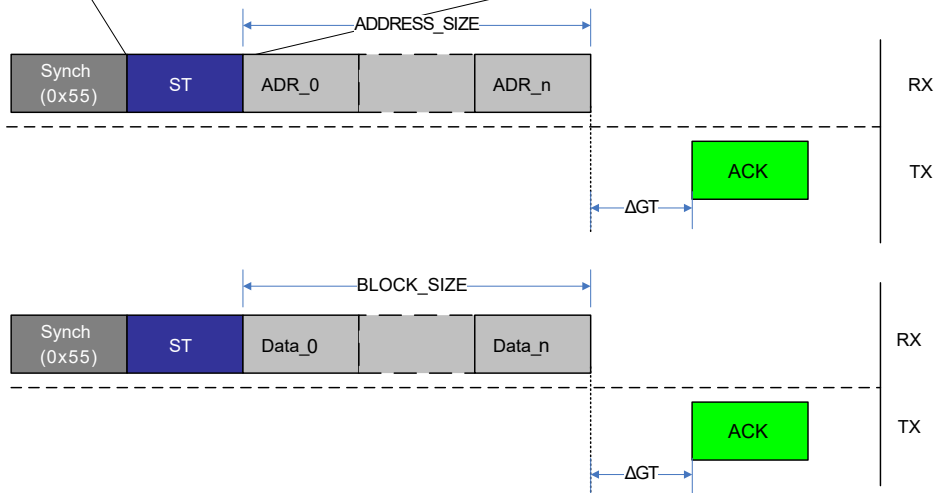
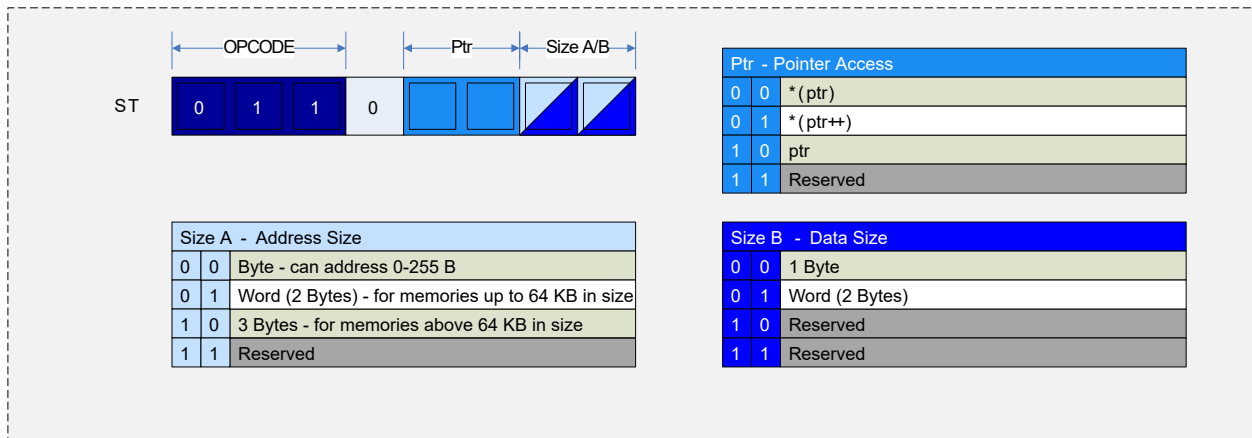

The figure above gives an example of an *ST* instruction to the UPDI Pointer register and the storage of regular data. A SYNCH character is sent before each instruction. In both cases, an Acknowledge (ACK) is sent back by the UPDI if the *ST* instruction was successful.

To write the UPDI Pointer register, the following procedure has to be followed:

1. Set the PTR field in the *ST* instruction to signature 0x2.
2. Set the address size (Size A) field to the desired address size.
3. After issuing the *ST* instruction, send Size A bytes of address data.
4. Wait for the ACK character, which signifies a successful write to the Address register.

After the Address register is written, sending data is done in a similarly:

1. Set the PTR field in the *ST* instruction to signature 0x0 to write to the address specified by the UPDI Pointer register. If the PTR field is set to 0x1, the UPDI pointer is automatically updated to the next address according to the data size Size B field of the instruction after the write is executed.
2. Set the Size B field in the instruction to the desired data size.
3. After sending the *ST* instruction, send Size B bytes of data.
4. Wait for the ACK character, which signifies a successful write to the bus matrix.

When used with the `REPEAT` instruction, it is recommended to set up the Address register with the start address for the block to be written and use the Pointer Post Increment register to automatically increase the address for each repeat cycle. When using the `REPEAT` instruction, the data frame of Size B data bytes can be sent after each received ACK.

31.3.3.5 LDCS - Load Data from Control and Status Register Space

The `LDCS` instruction is used to load serial readout data from the UPDI Control and the Status register space located in the DL layer into the PHY layer shift register. The `LDCS` instruction is based on direct addressing, where the address is part of the instruction operands. The `LDCS` instruction can access only the UPDI CS register space. This instruction supports only byte access, and the data size is not configurable.

Figure 31-12. LDCS Instruction Operation

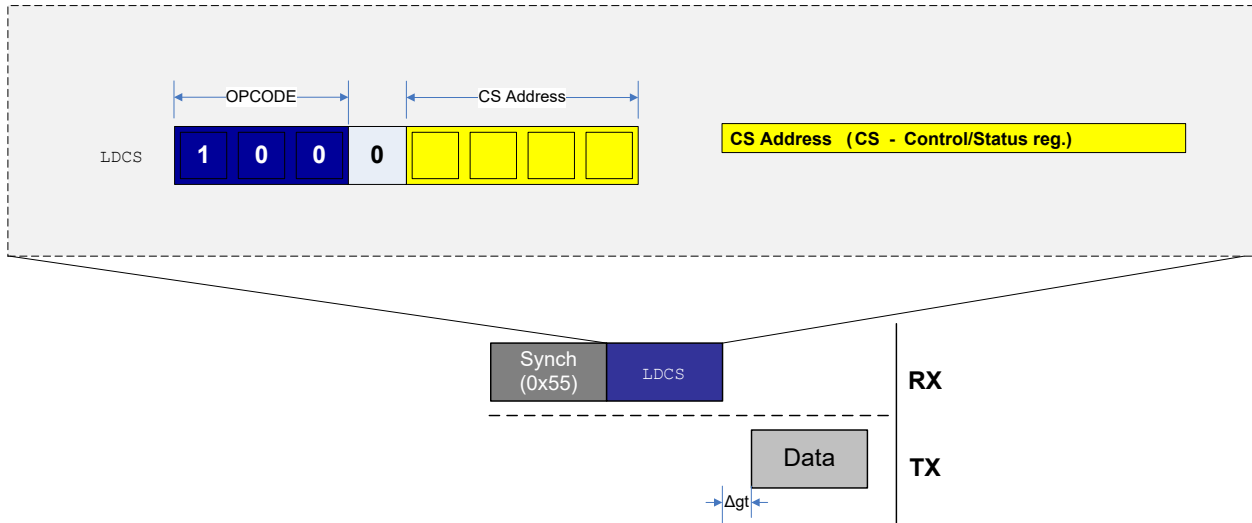

Figure 31-12 shows a typical example of `LDCS` data transmission. A data byte from the `LDCS` is transmitted from the UPDI after the guard time is completed.

31.3.3.6 STCS - Store Data to Control and Status Register Space

The `STCS` instruction is used to store data to the UPDI Control and Status register space. Data are shifted in serially into the PHY layer shift register and written as a whole byte to a selected CS register. The `STCS` instruction is based on direct addressing, where the address is part of the instruction operand. The `STCS` instruction can access only the internal UPDI register space. This instruction supports only byte access, and the data size is not configurable.

Figure 31-13. STCS Instruction Operation

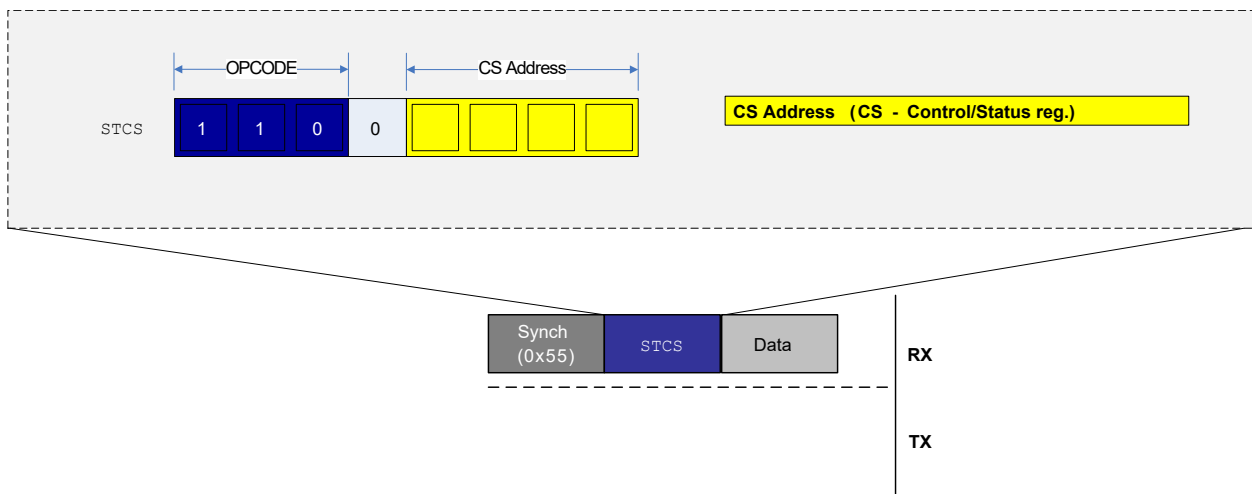

Figure 31-13 shows the data frame transmitted after the SYNCH character and the instruction frames. The STCS instruction byte can be immediately followed by the data byte. There is no response generated from the STCS instruction, as is the case for the ST and STS instructions.

31.3.3.7 REPEAT - Set Instruction Repeat Counter

The REPEAT instruction is used to store the repeat count value into the UPDI Repeat Counter register on the DL layer. When instructions are used with REPEAT, the protocol overhead for SYNCH and instruction frame can be omitted on all instructions except the first instruction after the REPEAT is issued. REPEAT is most useful for memory instructions (LD, ST, LDS, STS), but all instructions can be repeated, except for the REPEAT instruction itself.

The DATA_SIZE operand field refers to the size of the repeat value. Only up to 255 repeats are supported. The instruction loaded directly after the REPEAT instruction will be issued for $RPT_0 + 1$ times. If the Repeat Counter register is '0', the instruction will run just once. An ongoing repeat can be aborted only by sending a BREAK character.

Figure 31-14. REPEAT Instruction Operation used with ST Instruction

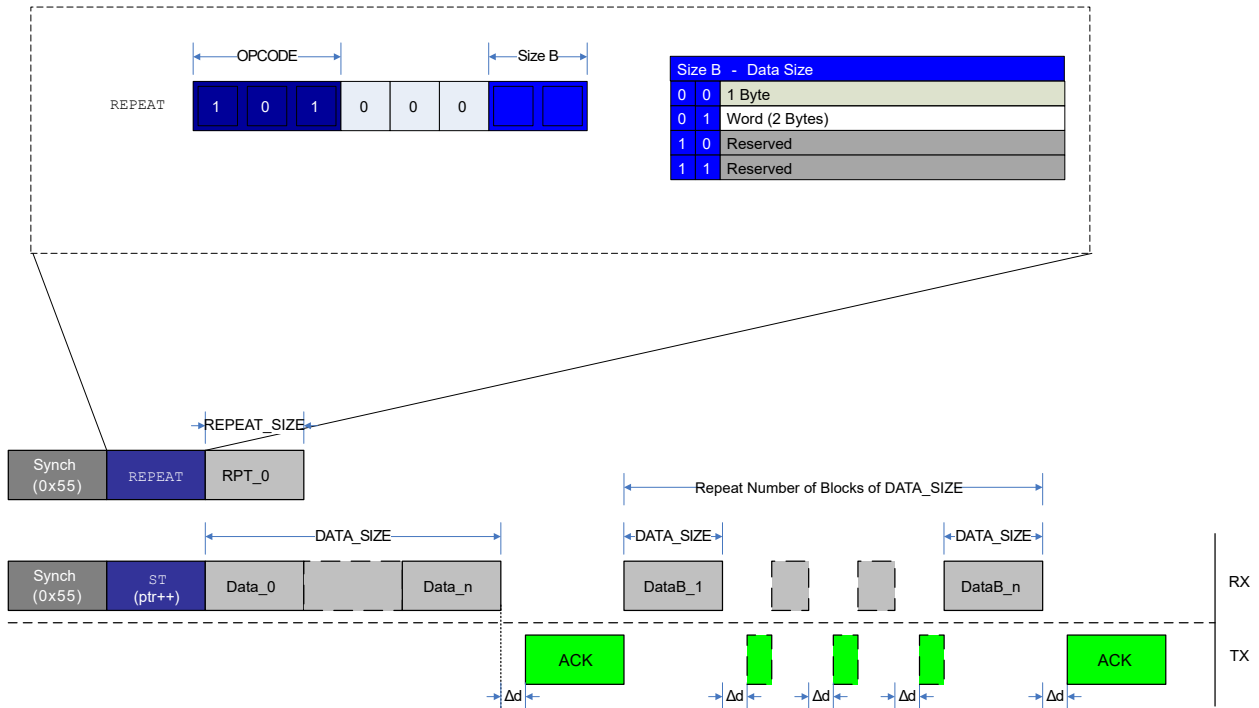
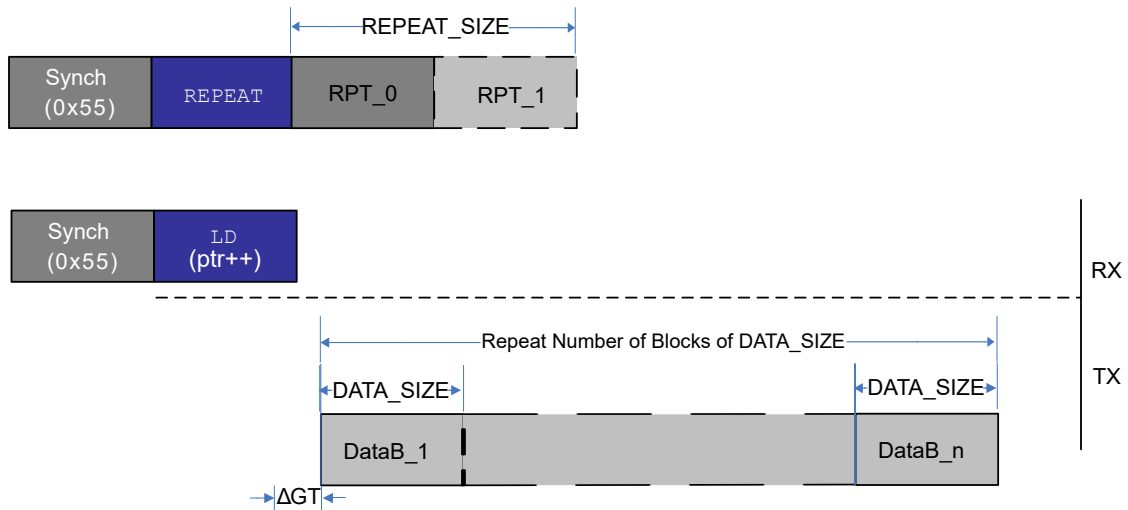

Figure 31-14 gives an example of a repeat operation with an ST instruction using pointer post-increment operation. After the REPEAT instruction is sent with $RPT_0 = n$, the first ST instruction is issued with SYNCH and instruction frame, while the next n ST instructions are executed by only sending data bytes according to the ST operand DATA_SIZE, and maintaining the Acknowledge (ACK) handshake protocol.

Figure 31-15. REPEAT used with LD Instruction



For LD, data will come out continuously after the LD instruction. Note the guard time on the first data block.

If using indirect addressing instructions (LD/ST), it is recommended to always use the pointer post-increment option when combined with REPEAT. The ST/LD instruction is necessary only before the first data block (number of data bytes determined by DATA_SIZE). Otherwise, the same address will be accessed in all repeated access operations. For direct addressing instructions (LDS/STS), the address must always be transmitted as specified in the instruction protocol, before data can be received (LDS) or sent (STS).

31.3.3.8 KEY - Set Activation Key or Send System Information Block

The KEY instruction is used for communicating key bytes to the UPDI or for providing the programmer with a System Information Block (SIB), opening up for executing protected features on the device. See *Key Activation Overview* for an overview of functions that are activated by keys. For the KEY instruction, only a 64-bit key size is supported. The maximum supported size for SIB is 128 bits.

Figure 31-16. KEY Instruction Operation

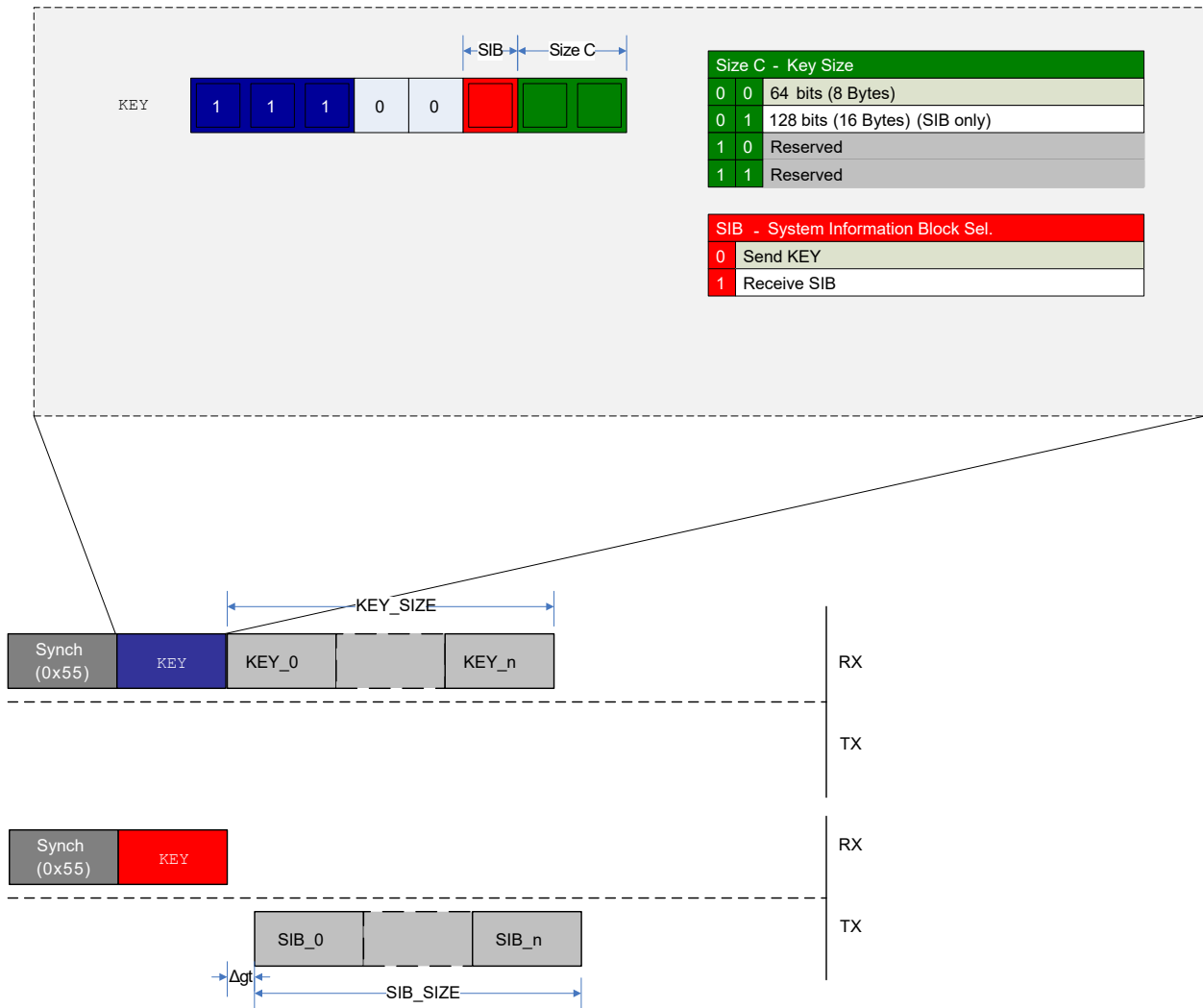

Figure 31-16 shows the transmission of a key and the reception of a SIB. In both cases, the Size C (`SIZE_C`) field in the operand determines the number of frames being sent or received. There is no response after sending a `KEY` to the UPDI. When requesting the SIB, data will be transmitted from the UPDI according to the current guard time setting.

31.3.4 CRC Checking of Flash During Boot

Some devices support running a CRC check of the Flash contents as part of the boot process. This check can be performed even when the device is locked. The result of this CRC check can be read from the `ASI_CRC_STATUS` register. Refer to the *CRCSCAN* section in the device data sheet for more information on this feature.

31.3.5 System Clock Measurement with UPDI

It is possible to use the UPDI to get an accurate measurement of the system clock frequency by utilizing the UPDI event connected to TCB with Input Capture capabilities. A recommended setup flow for this feature is given by the following steps:

- Set up `TCBn.CTRLB` with setting `CNTMODE = 0x3`, Input Capture Frequency Measurement mode
- Write `CAPTEI = 1` in `TCBn.EVCTRL` to enable Event Interrupt. Keep `EDGE = 0` in `TCBn.EVCTRL`
- Configure the Event System to route the UPDI SYNCH event (generator) to the TCB (user)
- For the SYNCH character used to generate the UPDI events, it is recommended to use a slow baud rate in the range of 10-50 kbps to get a more accurate measurement of the value captured by the timer between each UPDI event. One particular thing is that if the capture is set up to trigger an interrupt, the first captured value

must be ignored. The second captured value based on the input event must be used for the measurement. See [Figure 31-17](#) for an example using 10 kbps UPDI SYNCH character pulses, giving a capture window of 200 μ s for the timer.

- It is possible to read out the captured value directly after the SYNCH character by reading the TCBn.CCMP register, or the value can be written to memory by the CPU once the capture is done. For more details, refer to the *TCB - 16-bit Timer/Counter Type B* section.

Figure 31-17. UPDI System Clock Measurement Events

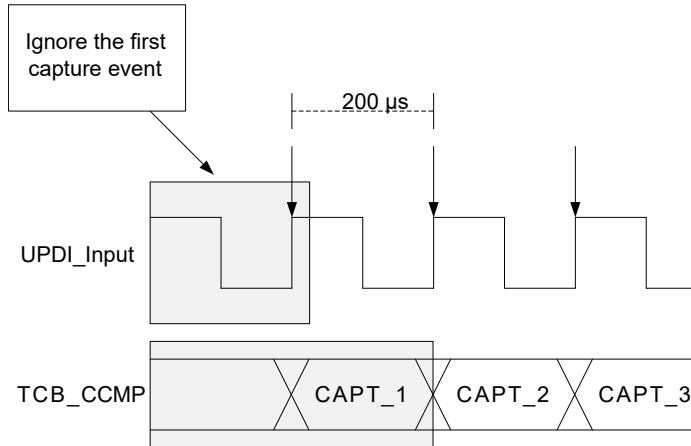

31.3.6 Inter-Byte Delay

When performing a multibyte transfer (`LD` combined with `REPEAT`), or reading out the System Information Block (SIB), the output data will come out in a continuous stream. Depending on the application, on the receiver side, the data might come out too fast, and there might not be enough time for the data to be processed before the next Start bit arrives.

The inter-byte delay works by inserting a fixed number of Idle bits for multibyte transfers. The reason for adding an inter-byte delay is that there is no guard time inserted when all data is going in the same direction.

The inter-byte delay feature can be enabled by writing a '1' to the Inter-Byte Delay Enable (IBDLY) bit in the Control A (UPDI.CTRLA) register. As a result, two extra Idle bits will be inserted between each byte to relax the sampling time for the debugger.

Figure 31-18. Inter-Byte Delay Example with `LD` and `RPT`

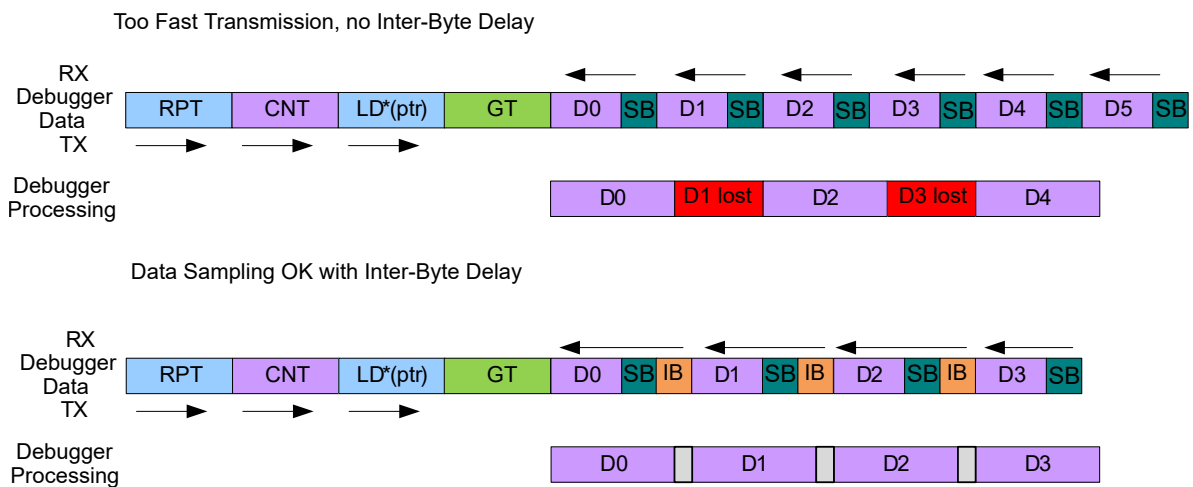

Notes:

1. GT denotes the guard time insertion.
2. SB is for Stop bit.
3. IB is the inserted inter-byte delay.
4. The rest of the frames are data and instructions.

31.3.7 System Information Block

The System Information Block (SIB) can be read out at any time by setting the SIB bit according to the `KEY` instruction from 31.3.3.8. `KEY - Set Activation Key or Send System Information Block`. The SIB is always accessible to the debugger, regardless of lock bit settings, and provides a compact form of supplying information about the device and system parameters for the debugger. The information is vital in identifying and setting up the proper communication channel with the device. The output of the SIB is interpreted as ASCII symbols. The key size field must be set to 16 bytes when reading out the complete SIB, and an 8-byte size can be used to read out only the Family_ID. See Figure 31-19 for SIB format description and which data are available at different readout sizes.

Figure 31-19. System Information Block Format

16	8	[Byte][Bits]	Field Name
16	8	[6:0] [55:0]	Family_ID
		[7][7:0]	Reserved
	8	[10:8][23:0]	NVM_VERSION
	8	[13:11][23:0]	OCD_VERSION
	8	[14][7:0]	RESERVED
	8	[15][7:0]	DBG_OSC_FREQ

31.3.8 Enabling of Key Protected Interfaces

The access to some internal interfaces and features is protected by the UPDI key mechanism. To activate a key, the correct key data must be transmitted by using the `KEY` instruction, as described in 31.3.3.8. `KEY - Set Activation Key or Send System Information Block`. Table 31-4 describes the available keys and the condition required when doing the operation with the key active.

Table 31-4. Key Activation Overview

Key Name	Description	Requirements for Operation	Conditions for Key Invalidation
Chip Erase	Start NVM chip erase. Clear lock bits	-	UPDI Disable/UPDI Reset
NVMPROG	Activate NVM Programming	Lock bits cleared. ASI_SYS_STATUS.NVMPROG set	Programming done/UPDI Reset
USERROW-Write	Program the user row on the locked device	Lock bits set. ASI_SYS_STATUS.UROWPROG set	Write to key Status bit/ UPDI Reset

Table 31-5 gives an overview of the available key signatures that must be shifted in to activate the interfaces.

Table 31-5. Key Activation Signatures

Key Name	Key Signature (LSB Written First)	Size
Chip Erase	0x4E564D4572617365	64 bits
NVMPROG	0x4E564D50726F6720	64 bits
USERROW-Write	0x4E564D5573267465	64 bits

31.3.8.1 Chip Erase

The following steps should be followed to issue a chip erase:

1. Enter the Chip Erase key by using the `KEY` instruction. See Table 31-5 for the CHIPERASE signature.

2. **Optional:** Read the Chip Erase (CHIPERASE) bit in the ASI Key Status (UPDI.ASI_KEY_STATUS) register to see that the key is successfully activated.
3. Write the signature to the Reset Request (RSTREQ) bit in the ASI Reset Request (UPDI.ASI_RESET_REQ) register. This will issue a System Reset.
4. Write 0x00 to the ASI Reset Request (UPDI.ASI_RESET_REQ) register to clear the System Reset.
5. Read the NVM Lock Status (LOCKSTATUS) bit from the ASI System Status (UPDI.ASI_SYS_STATUS) register.
6. The chip erase is done when LOCKSTATUS bit is '0'. If the LOCKSTATUS bit is '1', return to step 5.

After a successful Chip Erase, the Lockbits will be cleared, and the UPDI will have full access to the system. Until Lockbits are cleared, the UPDI cannot access the system bus, and only CS-space operations can be performed.



During chip erase, the BOD is forced in ON state by writing to the Active (ACTIVE) bit field from the Control A (BOD.CTRLA) register and uses the BOD Level (LVL) bit field from the BOD Configuration (FUSE.BODCFG) fuse and the BOD Level (LVL) bit field from the Control B (BOD.CTRLB) register. If the supply voltage V_{DD} is below that threshold level, the device is unavailable until V_{DD} is increased adequately. See the *BOD* section for more details.

31.3.8.2 NVM Programming

If the device is unlocked, it is possible to write directly to the NVM Controller or to the Flash memory using the UPDI. This will lead to unpredictable code execution if the CPU is active during the NVM programming. To avoid this, the following NVM Programming sequence has to be executed.

1. Follow the chip erase procedure, as described in *Chip Erase*. If the part is already unlocked, this point can be skipped.
2. Enter the NVMPROG key by using the `KEY` instruction. See [Table 31-5](#) for the NVMPROG signature.
3. **Optional:** Read the NVM Programming Key Status (NVMPROG) bit from the ASI Key Status (UPDI.KEY_STATUS) register to see if the key has been activated.
4. Write the signature to the Reset Request (RSTREQ) bit in the ASI Reset Request (UPDI.ASI_RESET_REQ) register. This will issue a System Reset.
5. Write 0x00 to the ASI Reset Request (UPDI.ASI_RESET_REQ) register to clear the System Reset.
6. Read the NVM Programming Key Status (NVMPROG) bit from the ASI System Status (UPDI.ASI_SYS_STATUS) register.
7. NVM Programming can start when the NVMPROG bit is '1'. If the NVMPROG bit is '0', return to step 6.
8. Write data to NVM through the UPDI.
9. Write the signature to the Reset Request (RSTREQ) bit in the ASI Reset Request (UPDI.ASI_RESET_REQ) register. This will issue a System Reset.
10. Write 0x00 to the ASI Reset Request (UPDI.ASI_RESET_REQ) register to clear the System Reset.
11. Programming is complete.

31.3.8.3 User Row Programming

The User Row Programming feature allows programming new values to the user row (USERROW) on a locked device. To program with this functionality enabled, the following sequence must be followed:

1. Enter the USERROW-Write key located in [Table 31-5](#) by using the `KEY` instruction. See [Table 31-5](#) for the USERROW-Write signature.
2. **Optional:** Read the User Row Write Key Status (UROWWRITE) bit from the ASI Key Status (UPDI.ASI_KEY_STATUS) register to see if the key has been activated.
3. Write the signature to the Reset Request (RSTREQ) bit in the ASI Reset Request (UPDI.ASI_RESET_REQ) register. This will issue a System Reset.
4. Write 0x00 to the ASI Reset Request (UPDI.ASI_RESET_REQ) register to clear the System Reset.
5. Read the Start User Row Programming (UROWPROG) bit from the ASI System Status (UPDI.ASI_SYS_STATUS) register.
6. User Row Programming can start when the UROWPROG bit is '1'. If UROWPROG is '0', return to step 5.

ATtiny3224/3226/3227

UPDI - Unified Program and Debug Interface

7. The data to be written to the User Row must first be written to a buffer in the RAM. The writable area in the RAM has a size of 32 bytes, and it is only possible to write user row data to the first 32 byte addresses of the RAM. Addressing outside this memory range will result in a nonexecuted write. The data will map 1:1 with the user row space when the data is copied into the user row upon completion of the Programming sequence.
8. When all user row data has been written to the RAM, write the User Row Programming Done (UROWDONE) bit in the ASI System Control A (UPDI.ASI_SYS_CTRLA) register.
9. Read the Start User Row Programming (UROWPROG) bit from the ASI System Status (UPDI.ASI_SYS_STATUS) register.
10. The User Row Programming is completed when UROWPROG bit is '0'. If UROWPROG bit is '1', return to step 9.
11. Write to the User Row Write Key Status (UROWWRITE) bit in the ASI Key Status (UPDI.ASI_KEY_STATUS) register.
12. Write the signature to the Reset Request (RSTREQ) bit in the ASI Reset Request (UPDI.ASI_RESET_REQ) register. This will issue a System Reset.
13. Write 0x00 to the ASI Reset Request (UPDI.ASI_RESET_REQ) register to clear the System Reset.
14. The User Row Programming is complete.

It is not possible to read back data from the RAM in this mode. Only writes to the first 32 bytes of the RAM are allowed.

31.3.9 Events

The UPDI can generate the following events:

Table 31-6. Event Generators in UPDI

Generator Name		Description	Event Type	Generating Clock Domain	Length of Event
Module	Event				
UPDI	SYNCH	SYNCH character	Level	CLK_UPDI	SYNCH char on UPDI pin synchronized to CLK_UPDI

This event is set on the UPDI clock for each detected positive edge in the SYNCH character, and it is not possible to disable this event from the UPDI.

The UPDI has no event users.

Refer to the *Event System* section for more details regarding event types and Event System configuration.

31.3.10 Sleep Mode Operation

The UPDI PHY layer runs independently of all sleep modes, and the UPDI is always accessible for a connected debugger independent of the device's sleep state. If the system enters a sleep mode that turns the system clock off, the UPDI will not be able to access the system bus and read memories and peripherals. When enabled, the UPDI will request the system clock so that the UPDI always has contact with the rest of the device. Thus, the UPDI PHY layer clock is unaffected by the sleep mode's settings. By reading the System Domain in Sleep (INSLEEP) bit in the ASI System Status (UPDI.ASI_SYS_STATUS) register, it is possible to monitor if the system domain is in a sleep mode.

It is possible to prevent the system clock from stopping when going into a sleep mode, by writing to the Request System Clock (CLKREQ) bit in the ASI System Control A (UPDI.ASI_SYS_CTRLA) register. If this bit is set, the system sleep mode state is emulated, and the UPDI can access the system bus and read the peripheral registers even in the deepest sleep modes.

The CLKREQ bit is by default '1' when the UPDI is enabled, which means that the default operation is keeping the system clock in ON state during the sleep modes.

31.4 Register Summary

Offset	Name	Bit Pos.	7	6	5	4	3	2	1	0
0x00	STATUSA	7:0	UPDIREV[3:0]							
0x01	STATUSB	7:0							PESIG[2:0]	
0x02	CTRLA	7:0	IBDLY		PARD	DTD	RSD		GTVAL[2:0]	
0x03	CTRLB	7:0				NACKDIS	CCDETDIS	UPDIDIS		
0x04	Reserved									
0x06										
0x07	ASI_KEY_STATUS	7:0			UROWWRITE	NVMPROG	CHIPERASE			
0x08	ASI_RESET_REQ	7:0	RSTREQ[7:0]							
0x09	ASI_CTRLA	7:0							UPDICKSEL[1:0]	
0x0A	ASI_SYS_CTRLA	7:0							UROWWRITE_FINAL	CLKREQ
0x0B	ASI_SYS_STATUS	7:0			RSTSYS	INSLEEP	NVMPROG	UROWPROG		LOCKSTATUS
0x0C	ASI_CRC_STATUS	7:0							CRC_STATUS[2:0]	

31.5 Register Description

These registers are readable only through the UPDI with special instructions and are not readable through the CPU.

31.5.1 Status A

Name: STATUSA
Offset: 0x00
Reset: 0x40
Property: -

Bit	7	6	5	4	3	2	1	0
	UPDIREV[3:0]							
Access	R	R	R	R				
Reset	0	1	0	0				

Bits 7:4 – UPDIREV[3:0] UPDI Revision
 This bit field contains the revision of the current UPDI implementation.

31.5.2 Status B

Name: STATUSB
Offset: 0x01
Reset: 0x00
Property: -

	7	6	5	4	3	2	1	0	
							PESIG[2:0]		
Access						R	R	R	
Reset						0	0	0	

Bits 2:0 – PESIG[2:0] UPDI Error Signature

This bit field describes the UPDI error signature and is set when an internal UPDI Error condition occurs. The PESIG bit field is cleared on a read from the debugger.

Table 31-7. Valid Error Signatures

PESIG[2:0]	Error Type	Error Description
0x0	No error	No error detected (Default)
0x1	Parity error	Wrong sampling of the Parity bit
0x2	Frame error	Wrong sampling of the Stop bits
0x3	Access Layer Time-Out Error	UPDI can get no data or response from the Access layer
0x4	Clock Recovery error	Wrong sampling of the Start bit
0x5	-	Reserved
0x6	Bus error	Address error or access privilege error
0x7	Contention error	Signalize Driving Contention on the UPDI pin

31.5.3 Control A

Name: CTRLA
Offset: 0x02
Reset: 0x00
Property: -

Bit	7	6	5	4	3	2	1	0
	IBDLY		PARD	DTD	RSD	GTVAL[2:0]		
Access	R/W		R/W	R/W	R/W	R/W	R/W	R/W
Reset	0		0	0	0	0	0	0

Bit 7 – IBDLY Inter-Byte Delay Enable

Writing a '1' to this bit enables a fixed-length inter-byte delay between each data byte transmitted from the UPDI when doing multibyte LD(S). The fixed length is two IDLE bits.

Bit 5 – PARD Parity Disable

Writing a '1' to this bit will disable the parity detection in the UPDI by ignoring the Parity bit. This feature is recommended to be used only during testing.

Bit 4 – DTD Disable Time-Out Detection

Writing a '1' to this bit will disable the time-out detection on the PHY layer, which requests a response from the ACC layer within a specified time (65536 UPDI clock cycles).

Bit 3 – RSD Response Signature Disable

Writing a '1' to this bit will disable any response signatures generated by the UPDI. This reduces the protocol overhead to a minimum when writing large blocks of data to the NVM space. When accessing the system bus, the UPDI may experience delays. If the delay is predictable, the response signature may be disabled. Otherwise, a loss of data may occur.

Bits 2:0 – GTVAL[2:0] Guard Time Value

This bit field selects the guard time value that will be used by the UPDI when the transmission direction switches from RX to TX.

Value	Description
0x0	UPDI guard time: 128 cycles (default)
0x1	UPDI guard time: 64 cycles
0x2	UPDI guard time: 32 cycles
0x3	UPDI guard time: 16 cycles
0x4	UPDI guard time: 8 cycles
0x5	UPDI guard time: 4 cycles
0x6	UPDI guard time: 2 cycles
0x7	Reserved

31.5.4 Control B

Name: CTRLB
Offset: 0x03
Reset: 0x00
Property: -

	7	6	5	4	3	2	1	0
				NACKDIS	CCDETDIS	UPDIDIS		
Access				R/W	R/W	R/W		
Reset				0	0	0		

Bit 4 – NACKDIS Disable NACK Response

Writing a '1' to this bit disables the NACK signature sent by the UPDI when a System Reset is issued during ongoing LD(S) and ST(S) operations.

Bit 3 – CCDETDIS Collision and Contention Detection Disable

Writing a '1' to this bit disables the contention detection. Writing a '0' to this bit enables the contention detection.

Bit 2 – UPDIDIS UPDI Disable

Writing a '1' to this bit disables the UPDI PHY interface. The clock request from the UPDI is lowered, and the UPDI is reset. All the UPDI PHY configurations and keys will be reset when the UPDI is disabled.

31.5.5 ASI Key Status

Name: ASI_KEY_STATUS
Offset: 0x07
Reset: 0x00
Property: -

	7	6	5	4	3	2	1	0
			UROWWRITE	NVMPROG	CHIPERASE			
Access			R/W	R	R			
Reset			0	0	0			

Bit 5 – UROWWRITE User Row Write Key Status

This bit is set to '1' if the UROWWRITE key is successfully decoded. This bit must be written as the final part of the user row write procedure to correctly reset the programming session.

Bit 4 – NVMPROG NVM Programming Key Status

This bit is set to '1' if the NVMPROG key is successfully decoded. The bit is cleared when the NVM Programming sequence is initiated, and the NVMPROG bit in ASI_SYS_STATUS is set.

Bit 3 – CHIPERASE Chip Erase Key Status

This bit is set to '1' if the Chip Erase key is successfully decoded. The bit is cleared by the Reset Request issued as part of the Chip Erase sequence described in the *Chip Erase* section.

31.5.6 ASI Reset Request

Name: ASI_RESET_REQ
Offset: 0x08
Reset: 0x00
Property: -

A Reset is signaled to the System when writing the Reset signature to this register.

	7	6	5	4	3	2	1	0
	RSTREQ[7:0]							
Access	R/W	R/W	R/W	R/W	R/W	R/W	R/W	R/W
Reset	0	0	0	0	0	0	0	0

Bits 7:0 – RSTREQ[7:0] Reset Request

The UPDI will not be reset when issuing a System Reset from this register.

Value	Name	Description
0x00	RUN	Clear Reset condition
0x59	RESET	Normal Reset
Other	-	Reserved

31.5.7 ASI Control A

Name: ASI_CTRLA
Offset: 0x09
Reset: 0x03
Property: -

Bit	7	6	5	4	3	2	1	0
							UPDICKSEL[1:0]	
Access							R/W	R/W
Reset							1	1

Bits 1:0 – UPDICKSEL[1:0] UPDI Clock Divider Select

Writing these bits selects the UPDI clock output frequency. The default setting after Reset and enable is 4 MHz. Any other clock output selection is only recommended when the BOD is at the highest level. For all other BOD settings, the default 4 MHz selection is recommended.

Value	Description
0x0	Reserved
0x1	16 MHz UPDI clock
0x2	8 MHz UPDI clock
0x3	4 MHz UPDI clock (Default Setting)

31.5.8 ASI System Control A

Name: ASI_SYS_CTRLA
Offset: 0x0A
Reset: 0x00
Property: -

	7	6	5	4	3	2	1	0
							UROWWRITE_ FINAL	CLKREQ
Access	R	R	R	R	R	R	R/W	R/W
Reset	0	0	0	0	0	0	0	0

Bit 1 – UROWWRITE_FINAL User Row Programming Done

This bit must be written when the user row data have been written to the RAM. Writing a '1' to this bit will start the process of programming the user row data to the Flash.

If this bit is written before the user row data is written to the RAM by the UPDI, the CPU will proceed without the written data.

This bit is writable only if the USERROW-Write key is successfully decoded.

Bit 0 – CLKREQ Request System Clock

If this bit is written to '1', the ASI is requesting the system clock, independent of the system sleep modes. This makes it possible for the UPDI to access the ACC layer, also if the system is in a sleep mode.

Writing a '0' to this bit will lower the clock request.

This bit will be reset when the UPDI is disabled.

This bit is set by default when the UPDI is enabled in any programming mode (Fuse, high-voltage).

31.5.9 ASI System Status

Name: ASI_SYS_STATUS
Offset: 0x0B
Reset: 0x01
Property: -

Bit	7	6	5	4	3	2	1	0
			RSTSYS	INSLEEP	NVMPROG	UROWPROG		LOCKSTATUS
Access			R	R	R	R		R
Reset			0	0	0	0		1

Bit 5 – RSTSYS System Reset Active

When this bit is set to '1', there is an active Reset on the system domain. When this bit is set to '0', the system is not in the Reset state.

This bit is set to '0' on read.

A Reset held from the ASI_RESET_REQ register will also affect this bit.

Bit 4 – INSLEEP System Domain in Sleep

When this bit is set to '1', the system domain is in Idle or deeper Sleep mode. When this bit is set to '0', the system is not in any sleep mode.

Bit 3 – NVMPROG Start NVM Programming

When this bit is set to '1', NVM Programming can start from the UPDI.

When the programming is complete, reset the system through the UPDI Reset register.

Bit 2 – UROWPROG Start User Row Programming

When this bit is set to '1', User Row Programming can start from the UPDI.

When the User Row data have been written to the RAM, the UROWDONE bit in the ASI_SYS_CTRLA register must be written.

Bit 0 – LOCKSTATUS NVM Lock Status

When this bit is set to '1', the device is locked. If a chip erase is done, and the lock bits are set to '0', this bit will be read as '0'.

31.5.10 ASI CRC Status

Name: ASI_CRC_STATUS
Offset: 0x0C
Reset: 0x00
Property: -

	7	6	5	4	3	2	1	0	
							CRC_STATUS[2:0]		
Access							R	R	R
Reset							0	0	0

Bits 2:0 – CRC_STATUS[2:0] CRC Execution Status

This bit field signalizes the status of the CRC conversion. This bit field is one-hot encoded.

Value	Description
0x0	Not enabled
0x1	CRC enabled, busy
0x2	CRC enabled, done with OK signature
0x4	CRC enabled, done with FAILED signature
Other	Reserved

32. Instruction Set Summary

The instruction set summary is part of the *AVR Instruction Set Manual*, located at www.microchip.com/DS40002198. Refer to the CPU version called AVRxt, for details regarding the devices documented in this data sheet.

33. Electrical Characteristics

33.1 Disclaimer

All typical values are measured at $T = 25^{\circ}\text{C}$ and $V_{\text{DD}} = 3\text{V}$ unless otherwise specified. All minimum and maximum values are valid across operating temperature and voltage unless otherwise specified.

Typical values given should be considered for design guidance only, and actual part variation around these values is expected.

33.2 Absolute Maximum Ratings

Stresses beyond those listed in this section may cause permanent damage to the device. This is a stress rating only and functional operation of the device at these or other conditions beyond those indicated in the operational sections of this specification is not implied. Exposure to absolute maximum rating conditions for extended periods may affect device reliability.

Table 33-1. Absolute Maximum Ratings

Symbol	Description	Conditions	Min.	Max.	Unit
V_{DD}	Power supply voltage		-0.5	6	V
I_{VDD}	Current into a VDD pin	$T = [-40, 85]^{\circ}\text{C}$	-	200	mA
		$T = [85, 125]^{\circ}\text{C}$	-	100	mA
I_{GND}	Current out of a GND pin	$T = [-40, 85]^{\circ}\text{C}$	-	200	mA
		$T = [85, 125]^{\circ}\text{C}$	-	100	mA
V_{RST}	$\overline{\text{RESET}}$ pin voltage with respect to GND		-0.5	13	V
V_{PIN}	Pin voltage with respect to GND		-0.5	$V_{\text{DD}}+0.5$	V
I_{PIN}	I/O pin sink/source current		-40	40	mA
$I_{\text{c1}}^{(1)}$	I/O pin injection current except $\overline{\text{RESET}}$ pin	$V_{\text{PIN}} < \text{GND} - 0.6\text{V}$ or $5.5\text{V} < V_{\text{PIN}} \leq 6.1\text{V}$ $4.9\text{V} < V_{\text{DD}} \leq 5.5\text{V}$	-1	1	mA
$I_{\text{c2}}^{(1)}$	I/O pin injection current except $\overline{\text{RESET}}$ pin	$V_{\text{PIN}} < \text{GND} - 0.6\text{V}$ or $V_{\text{PIN}} \leq 5.5\text{V}$ $V_{\text{DD}} \leq 4.9\text{V}$	-15	15	mA
I_{ctot}	Sum of I/O pin injection current except $\overline{\text{RESET}}$ pin		-45	45	mA
T_{storage}	Storage temperature		-65	150	$^{\circ}\text{C}$

Note:

1. If the V_{PIN} is lower than $\text{GND} - 0.6\text{V}$, then a current limiting resistor is required. The negative DC injection current limiting resistor is calculated as $R = (\text{GND} - 0.6\text{V} - V_{\text{PIN}})/I_{\text{Cn}}$.
If the V_{PIN} is greater than $V_{\text{DD}}+0.6\text{V}$, then a current limiting resistor is required. The positive DC injection current limiting resistor is calculated as $R = (V_{\text{PIN}} - (V_{\text{DD}} + 0.6))/I_{\text{Cn}}$.



$V_{RSTMAX} = 13V$

Care should be taken to avoid overshoot (overvoltage) when connecting the RESET pin to a 12V source. Exposing the pin to a voltage above the rated absolute maximum can activate the pin's ESD protection circuitry, which will remain activated until the voltage has been brought below approximately 10V. A 12V driver can keep the ESD protection in an activated state (if activated by an overvoltage condition) while driving currents through it, potentially causing permanent damage to the part.

33.3 General Operating Ratings

The device must operate within the ratings listed in this section for all other electrical characteristics and typical characteristics of the device to be valid.

Table 33-2. General Operating Conditions

Symbol	Description	Condition	Min.	Max.	Unit
V_{DD}	Operating supply voltage	Industrial	1.8 ^(1,2)	5.5	V
		VAO - Auto Grade and Extended Operating temperature range	2.7 ^(2,3)	5.5	V
T_A	Operating temperature range	Extended	-40	125	°C
		Industrial	-40	85	

Notes:

1. Operation is ensured down to 1.8V or BOD triggering level V_{BOD} when BOD is active.
2. During Chip Erase, the BOD is forced ON. If the supply voltage V_{DD} is below the configured V_{BOD} , the erase attempt will fail.
3. Operation is ensured down to 2.7V or BOD triggering level V_{BOD} when BOD is active.

Table 33-3. Operating Voltage and Frequency

Symbol	Description	Condition	Min.	Max.	Unit	
f_{CLK_CPU}	Nominal operating system clock frequency	$T_A = [-40, 85]^\circ C$	$V_{DD} = [1.8, 2.7]V^{(1,4)}$	0	5	MHz
			$V_{DD} = [2.7, 4.5]V^{(2)}$	0	10	
			$V_{DD} = [4.5, 5.5]V^{(3)}$	0	20	
		$T_A = [85, 125]^\circ C$	$V_{DD} = [2.7, 4.5]V^{(2)}$	0	8	
			$V_{DD} = [4.5, 5.5]V^{(3)}$	0	16	

Notes:

1. Operation is ensured down to BOD triggering level, V_{BOD} with BODLEVEL0.
2. Operation is ensured down to BOD triggering level, V_{BOD} with BODLEVEL2.
3. Operation is ensured down to BOD triggering level, V_{BOD} with BODLEVEL7.
4. These specifications do not apply to automotive range parts (-VAO).

The maximum CPU clock frequency depends on V_{DD} . As shown in the figure below, the Maximum Frequency vs. V_{DD} is linear between $1.8V < V_{DD} < 2.7V$ and $2.7V < V_{DD} < 4.5V$.

Figure 33-1. Maximum Frequency vs. V_{DD} for [-40, 85]°C

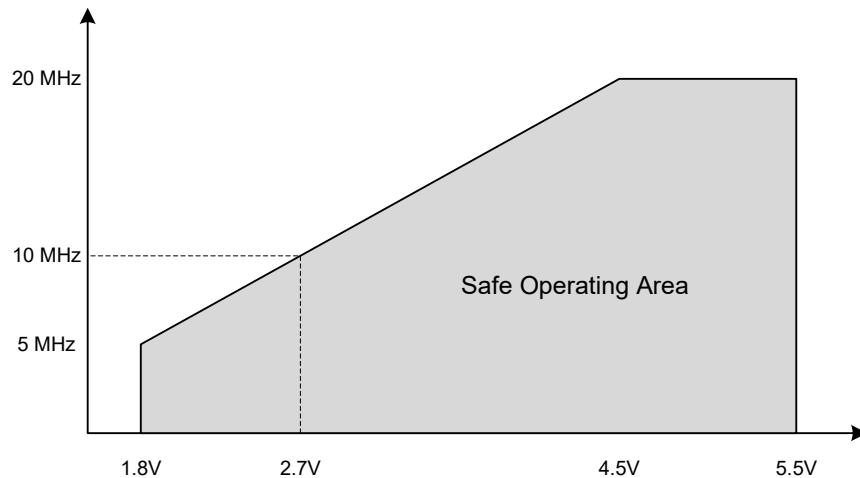
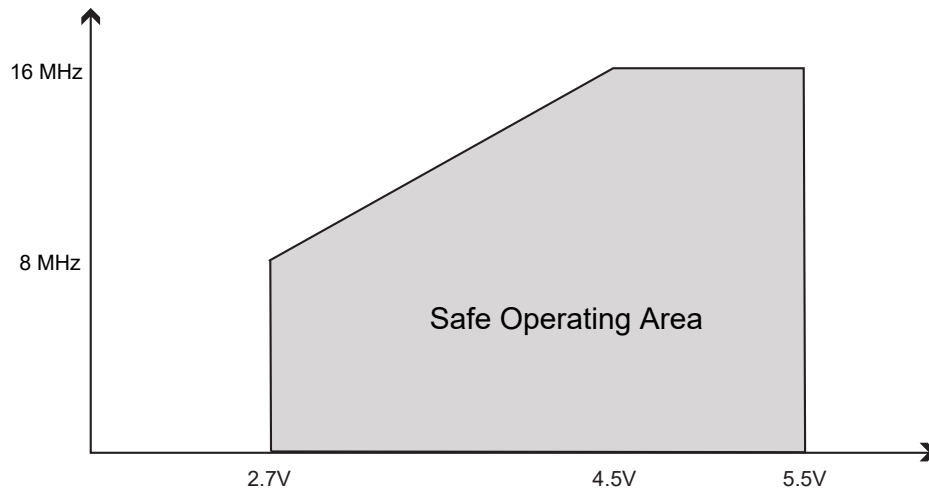

Figure 33-2. Maximum Frequency vs. V_{DD} for [85, 125]°C



33.4 Power Considerations

The average chip-junction temperature, T_J , in °C, can be obtained from the following equations:

- **Equation 1:** $T_J = T_A + (P_D \times \theta_{JA})$
- **Equation 2:** $T_J = T_A + (P_D \times (\theta_{HEATSINK} + \theta_{JC}))$

where:

- θ_{JA} = Package thermal resistance, Junction-to-ambient (°C/W), see table below
- θ_{JC} = Package thermal resistance, Junction-to-case thermal resistance (°C/W), see table below
- $\theta_{HEATSINK}$ = Thermal resistance (°C/W) specification of the external cooling device
- P_D = Device power consumption (W)
- T_A = Ambient temperature (°C)

From the first equation, the user can derive the estimated lifetime of the chip and decide whether a cooling device is necessary or not. If a cooling device has to be fitted on the chip, the second equation must be used to compute the resulting average chip-junction temperature T_J in °C.

Power usage can be calculated by adding together the system power consumption and the I/O module power consumption. The current drawn from pins with a capacitive load may be estimated (for one pin) as follows:

$$I_{cp} \approx V_{DD} \times C_{load} \times f_{sw}$$

Where C_{load} = pin load capacitance and f_{sw} = average switching frequency of I/O pin.

Table 33-4. Power Dissipation and Junction Temperature vs. Temperature

Pin Count	Package Type	θ_{JA} (°C/W)	θ_{JC} (°C/W)
14	SOIC	58	26
14	TSSOP	95	20
20	SOIC	44	21
20	SSOP	60.6	25
20	VQFN	79.7	36
24	VQFN	60.6	25

33.5 Power Consumption

Operating conditions:

- $V_{DD} = 3V$
- $T = 25^{\circ}C$
- OSC20M used as the system clock source, unless otherwise specified
- System power consumption measured with peripherals disabled and without I/O drive

Table 33-5. Power Consumption in Active, Idle, Power-Down, Standby and Reset Mode

Mode	Description	Condition	Min.	Typ.	Max.	Unit	
Active	Active power consumption	CLK_CPU = 20 MHz (OSC20M)	$V_{DD} = 5V$	-	9.1	-	mA
		CLK_CPU = 10 MHz (OSC20M div2)	$V_{DD} = 5V$	-	4.9	-	mA
			$V_{DD} = 3V$	-	2.8	-	mA
		CLK_CPU = 5 MHz (OSC20M div4)	$V_{DD} = 5V$	-	2.8	-	mA
			$V_{DD} = 3V$	-	1.6	-	mA
			$V_{DD} = 2V$	-	1.1	-	mA
		CLK_CPU = 32.768 kHz (OSCULP32K)	$V_{DD} = 5V$	-	18	-	μA
			$V_{DD} = 3V$	-	10	-	μA
			$V_{DD} = 2V$	-	7.2	-	μA
Idle	Idle power consumption	CLK_CPU = 20 MHz (OSC20M)	$V_{DD} = 5V$	-	2.4	3.6 ⁽¹⁾	mA
		CLK_CPU = 10 MHz (OSC20M div2)	$V_{DD} = 5V$	-	1.4	2.1 ⁽¹⁾	mA
			$V_{DD} = 3V$	-	0.8	1.2 ⁽¹⁾	mA
		CLK_CPU = 5 MHz (OSC20M div4)	$V_{DD} = 5V$	-	1.0	1.5 ⁽¹⁾	mA
			$V_{DD} = 3V$	-	0.6	0.9	mA
			$V_{DD} = 2V$	-	0.4	-	mA
		CLK_CPU = 32.768 kHz (OSCULP32K)	$V_{DD} = 5V$	-	4.8	15 ⁽¹⁾	μA
			$V_{DD} = 3V$	-	2.4	10 ⁽¹⁾	μA
			$V_{DD} = 2V$	-	1.5	-	μA

.....continued

Mode	Description	Condition	Min.	Typ.	Max.	Unit	
Standby	Standby power consumption	RTC running at 1.024 kHz from external XOSC32K (C _L = 7.5 pF)	-	0.7	-	μA	
			T = 25°C	0.7	2.0	μA	
		RTC running at 1.024 kHz from internal OSCULP32K	T = 85°C	-	-	6.0 ⁽¹⁾	μA
			T = 125°C	-	-	8.0	μA
Power Down/ Standby	Power-down/ Standby power consumption are the same when all peripherals are stopped	All peripherals stopped	T = 25°C	0.1	1.5	μA	
			T = 85°C	-	-	4.0 ⁽¹⁾	μA
			T = 125°C	-	-	7.0	μA
Reset	Reset power consumption	Reset line pulled low	-	100	-	μA	

Note:

1. These values are based on characterization and not covered by production test limits.

33.6 Wake-Up Time

The following table shows wake-up time from various sleep modes with various system clock sources. It also shows the start-up time from reset with no Unified Programming Interface (UPDI) connection active and with 0 ms start-up time (SUT) setting.

Table 33-6. Start-Up and Wake-Up Time

Symbol	Description	Clock Source	PDIV Division	f _{CLK_CPU}	V _{DD}	Min.	Typ.	Max.	Unit
t _{startup}	The start-up time from the release of any Reset source. Execution of first instruction. (Excluding CRCSCAN)	Any	Any	Any	Any	-	200	-	μs
t _{wakeup} ⁽¹⁾	Wake-up from Idle	OSC20M FREQSEL = 0x2	1	20 MHz	5V	-	1	-	
			2	10 MHz	3V	-	2		
			4	5 MHz	2V	-	4		
		OSC20M FREQSEL = 0x1	1	16 MHz	5V	-	1.2	-	
			2	8 MHz	3V	-	2.4	-	
		OSCULP32K	1	32.768 kHz	3V	-	700	-	
	Wake-up time from Standby or Power-down when clock source is stopped	OSC20M FREQSEL = 0x2	1	20 MHz	5V	-	12	-	
			2	10 MHz	3V	-	13	-	
			4	5 MHz	2V	-	15	-	
		OSC20M FREQSEL = 0x1	1	16 MHz	5V	-	16	-	
			2	8 MHz	3V	-	15	-	
		OSCULP32K	1	32.768 kHz	3V	-	750	-	

Note:

- The wake-up time is the time from the wake-up request is given until the peripheral clock is available on the clock output (CLKOUT) pin. All peripherals and modules start execution from the first clock cycle, except the CPU that is halted for four clock cycles before program execution starts.

Figure 33-3. Wake-Up Time Definition

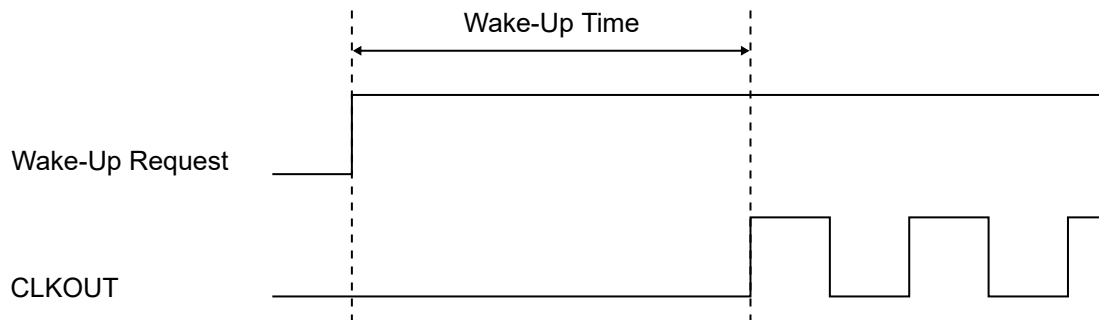

33.7 Peripherals Power Consumption

The table below can be used to calculate the additional current consumption for the different I/O peripherals in the various operating modes.

Some peripherals will request the clock to be enabled when operating in STANDBY. See the peripheral section for further information.

Operating conditions:

- V_{DD} = 3V
- T = 25°C

- OSC20M at 1 MHz used as the system clock source, unless otherwise specified
- In Idle sleep mode, unless otherwise specified

Table 33-7. Peripherals Power Consumption

Peripheral	Conditions	Typ. ⁽¹⁾	Unit
BOD	Continuous	19	μA
	Sampling @ 1 kHz	1.2	
TCA	16-bit count @ 1 MHz	13	μA
TCB	16-bit count @ 1 MHz	7.4	μA
RTC	16-bit count @ OSCULP32K	1.2	μA
WDT (including OSCULP32K)		0.7	μA
OSC20M		130	μA
AC	Low-Power mode disabled ⁽²⁾	92	μA
	Low-Power mode enabled ⁽²⁾	45	
ADC ⁽³⁾	CLK_ADC = 1MHz, VREF = Internal 2.048V	380	μA
XOSC32K	C _L = 7.5 pF	0.5	μA
OSCULP32K		0.4	μA
USART	Enable @ 9600 Baud	13	μA
SPI (Host)	Enable @ 100 kHz	2.1	μA
TWI (Host)	Enable @ 100 kHz	24	μA
TWI (Client)	Enable @ 100 kHz	17	μA
Flash programming	Erase Operation	1.5	mA
	Write Operation	3.0	

Notes:

1. Current consumption of the module only. To calculate the total internal power consumption of the microcontroller, power consumption values of all the peripherals and the clock sources used must be added to the base power consumption given in the *Power Consumption* section in electrical characteristics.
2. CPU in Standby mode.
3. Average power consumption with ADC active in Free-Running mode.

33.8 BOD and POR Characteristics

Table 33-8. Power Supply Characteristics

Symbol	Description	Condition	Min.	Typ.	Max.	Unit
SRON	Power-on Slope		-	-	100 ^(1,2)	V/ms

Notes:

1. For design guidance only and not tested in production.
2. A slope faster than the maximum rating can trigger a Reset of the device if changing the voltage level after an initial power-up.

Table 33-9. Power-on Reset (POR) Characteristics

Symbol	Description	Condition	Min.	Typ.	Max.	Unit
V _{POR}	POR threshold voltage on V _{DD} falling	V _{DD} falls/rises at 0.5 V/ms or slower	0.8 ⁽¹⁾	-	1.6 ⁽¹⁾	V
	POR threshold voltage on V _{DD} rising		1.4 ⁽¹⁾	-	1.8	

Note:

1. For design guidance only. Not tested in production.

Table 33-10. Brown-out Detector (BOD) Characteristics

Symbol	Description	Condition	Min.	Typ.	Max.	Unit
V _{BOD}	BOD detection level (falling/rising)	BODLEVEL0	1.7	1.8	2.0	V
		BODLEVEL2	2.4	2.6	2.9	
		BODLEVEL7	3.9	4.3	4.5	
V _{HYS}	Hysteresis	BODLEVEL0	-	25	-	mV
		BODLEVEL2	-	40	-	
		BODLEVEL7	-	80	-	
t _{BOD}	Detection time	Continuous	-	7	-	μs
		Sampled, 1 kHz	-	1	-	ms
		Sampled, 125 Hz	-	8	-	
t _{startup}	Start-up time	Time from enable to ready	-	40	-	μs
V _{INT}	Interrupt level 0	Percentage above the selected BOD level	-	4	-	%
	Interrupt level 1		-	13	-	
	Interrupt level 2		-	25	-	

33.9 External Reset Characteristics

Table 33-11. External Reset Characteristics

Mode	Description	Condition	Min.	Typ.	Max.	Unit
V _{VIH_RST}	Input Voltage for $\overline{\text{RESET}}$		$0.7 \times V_{DD}$	-	$V_{DD} + 0.2$	V
V _{VIL_RST}	Input Low Voltage for $\overline{\text{RESET}}$		-0.2	-	$0.3 \times V_{DD}$	
t _{MIN_RST}	Minimum pulse width on $\overline{\text{RESET}}$ pin		-	-	2.5 ⁽¹⁾	μs
R _{p_RST}	$\overline{\text{RESET}}$ pull-up resistor	V _{Reset} = 0V	20	35	50	kΩ

Note:

1. These parameters are for design guidance only and are not production tested.

33.10 Oscillators and Clocks

Operating conditions:

- V_{DD} = 3V, unless otherwise specified
- Oscillator frequencies above speed specification must be divided, so the CPU clock is always within specification

Table 33-12. 20 MHz Internal Oscillator (OSC20M) Characteristics

Symbol	Description	Condition	Min.	Typ.	Max.	Unit	
f _{OSC20M}	Factory calibration frequency	FREQSEL = 0x01	T _A = 25°C, 3.0V	-	16	-	MHz
		FREQSEL = 0x02		-	20	-	
f _{CAL}	Frequency calibration range	OSC20M FREQSEL = 0x01		14.5	-	17.5	MHz
		OSC20M FREQSEL = 0x02		18.5	-	21.5	MHz
E _{TOTAL}	Total error with 16 MHz and 20 MHz frequency selection	From target frequency	T _A = 25°C, 3.0V	-1.5	-	1.5	%
			T _A = [0, 70]°C, V _{DD} = [1.8, 3.6]V	-2.0 ⁽¹⁾	-	2.0 ⁽¹⁾	%
			Full operation range	-3.5	-	3.5	
Δf _{OSC20M}	Calibration step size		-	0.75	-	%	
D _{OSC20M}	Duty cycle		-	50	-	%	
t _{startup}	Start-up time	Within 2% accuracy	-	12	-	μs	

Note:

1. These values are based on characterization and are not covered by production test limits.

Table 33-13. 32.768 kHz Internal Oscillator (OSCULP32K) Characteristics

Symbol	Description	Condition	Min.	Typ.	Max.	Unit
f _{OSCULP32K}	Factory calibration frequency		-	32.768	-	kHz
	Factory calibration accuracy	T _A = 25°C, 3.0V	-3	-	3	%
E _{TOTAL}	Total error from target frequency	T _A = [0, 70]°C, V _{DD} = [1.8, 3.6]V	-10 ⁽¹⁾	-	+10 ⁽¹⁾	%
		Full operation range	-20	-	+20	
D _{OSCULP32K}	Duty cycle		-	50	-	%
t _{startup}	Start-up time		-	250	-	μs

Note:

1. These values are based on characterization and are not covered by production test limits.

Table 33-14. 32.768 kHz External Crystal Oscillator (XOSC32K) Characteristics

Symbol	Description	Condition	Min.	Typ.	Max.	Unit
f _{out}	Frequency		-	32.768	-	kHz
t _{startup}	Start-up time	C _L = 7.5 pF	-	300	-	ms
C _L	Crystal load capacitance		7.5 ⁽¹⁾	-	12.5 ⁽¹⁾	pF
ESR	Equivalent Series Resistance - Safety Factor=3	C _L = 7.5 pF	-	-	80 ⁽¹⁾	kΩ
		C _L = 12.5 pF	-	-	40 ⁽¹⁾	

Note:

1. This parameter is for design guidance only. Not production tested.

Figure 33-4. External Clock Waveform Characteristics

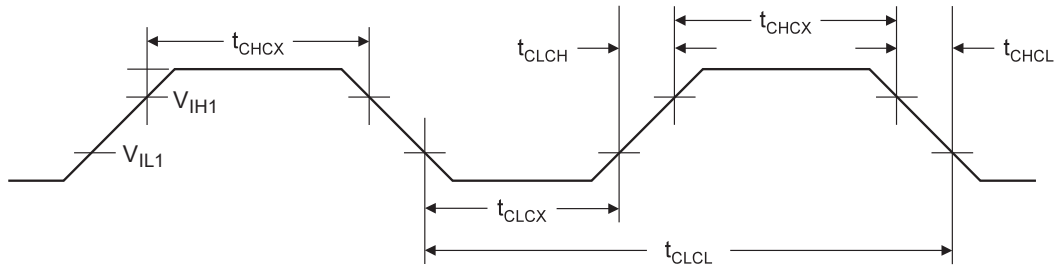

Table 33-15. External Clock Characteristics

Symbol	Description	Condition	V _{DD} =[1.8, 5.5]V		V _{DD} =[2.7, 5.5]V		V _{DD} =[4.5, 5.5]V		Unit
			Min.	Max.	Min.	Max.	Min.	Max.	
f _{CLCL}	Frequency		0	5.0	0.0	10.0	0.0	20.0	MHz
t _{CLCL}	Clock Period		200	-	100	-	50	-	ns
t _{CHCX} ⁽¹⁾	High Time		80	-	40	-	20	-	ns
t _{CLCX} ⁽¹⁾	Low Time		80	-	40	-	20	-	ns
t _{CLCH} ⁽¹⁾	Rise Time (for maximum frequency)		-	40	-	20	-	10	ns
t _{CHCL} ⁽¹⁾	Fall Time (for maximum frequency)		-	40	-	20	-	10	ns
Δt _{CLCL} ⁽¹⁾	Change in period from one clock cycle to the next		-	20	-	20	-	20	%

Note:

1. This parameter is for design guidance only. Not production tested.

33.11 I/O Pin Characteristics

Operating conditions:

- T_A = [-40, 125]°C
- V_{DD} = [1.8, 5.5]V, unless otherwise specified

Table 33-16. I/O Pin Characteristics

Symbol	Description	Condition	Min.	Typ.	Max.	Unit
V _{IL}	Input low-voltage, except RESET pin as I/O		-0.2	-	0.3 × V _{DD}	V
V _{IH}	Input high-voltage, except RESET pin as I/O		0.7 × V _{DD}	-	V _{DD} + 0.2V	V
I _{IH} / I _{IL}	I/O pin Input leakage current, except RESET pin as I/O	V _{DD} = 5.5V, Pin high	-	< 0.05	-	μA
		V _{DD} = 5.5V, Pin low	-	< 0.05	-	
V _{OL}	I/O pin drive strength	V _{DD} = 1.8V, I _{OL} = 1.5 mA	-	-	0.36	V
		V _{DD} = 3.0V, I _{OL} = 7.5 mA	-	-	0.6	
		V _{DD} = 5.0V, I _{OL} = 15 mA	-	-	1	
V _{OH}	I/O pin drive strength	V _{DD} = 1.8V, I _{OH} = 1.5 mA	1.44	-	-	V
		V _{DD} = 3.0V, I _{OH} = 7.5 mA	2.4	-	-	
		V _{DD} = 5.0V, I _{OH} = 15 mA	4	-	-	

ATtiny3224/3226/3227

Electrical Characteristics

.....continued

Symbol	Description	Condition	Min.	Typ.	Max.	Unit
I _{total}	Maximum combined I/O sink current per pin group ⁽¹⁾		-	-	100	mA
	Maximum combined I/O source current per pin group ⁽¹⁾		-	-	100	
V _{IL2}	Input low-voltage on $\overline{\text{RESET}}$ pin as I/O		-0.2	-	$0.3 \times V_{DD}$	V
V _{IH2}	Input high-voltage on $\overline{\text{RESET}}$ pin as I/O		$0.7 \times V_{DD}$	-	$V_{DD} + 0.2V$	V
V _{OL2}	I/O pin drive strength on $\overline{\text{RESET}}$ pin as I/O	V _{DD} = 1.8V, I _{OL} = 0.1 mA	-	-	0.36	V
		V _{DD} = 3.0V, I _{OL} = 0.25 mA	-	-	0.6	
		V _{DD} = 5.0V, I _{OL} = 0.5 mA	-	-	1	
V _{OH2}	I/O pin drive strength on $\overline{\text{RESET}}$ pin as I/O	V _{DD} = 1.8V, I _{OH} = 0.1 mA	1.44	-	-	V
		V _{DD} = 3.0V, I _{OH} = 0.25 mA	2.4	-	-	
		V _{DD} = 5.0V, I _{OH} = 0.5 mA	4	-	-	
t _{RISE}	Rise time	V _{DD} = 3.0V, load = 20 pF	-	2.5	-	ns
		V _{DD} = 5.0V, load = 20 pF	-	1.5	-	
t _{FALL}	Fall time	V _{DD} = 3.0V, load = 20 pF	-	2.0	-	ns
		V _{DD} = 5.0V, load = 20 pF	-	1.3	-	
CPIN	I/O pin capacitance, unless otherwise specified		-	4	-	pF
CPIN_TOSC	I/O pin capacitance on TOSC pins ⁽²⁾		-	5	-	pF
CPIN_TWI	I/O pin capacitance on TWI pins ⁽²⁾		-	12	-	pF
CPIN_AC	I/O pin capacitance on AC pins ⁽²⁾	PB0 and PB1	-	12	-	pF
		other AC pins	-	4	-	
CPIN_VREFA	I/O pin capacitance on ADC VREFA pin		-	14	-	pF
R _P	Pull-up resistor		20	35	50	kΩ

Notes:

1. Pin group x (Px[7:0]). The combined continuous sink/source current for all I/O ports should not exceed the limits.
2. This capacitance is valid for pins with this functionality, even when that functionality is not used.

33.12 USART

Figure 33-5. USART in SPI Mode - Timing Requirements in Host Mode

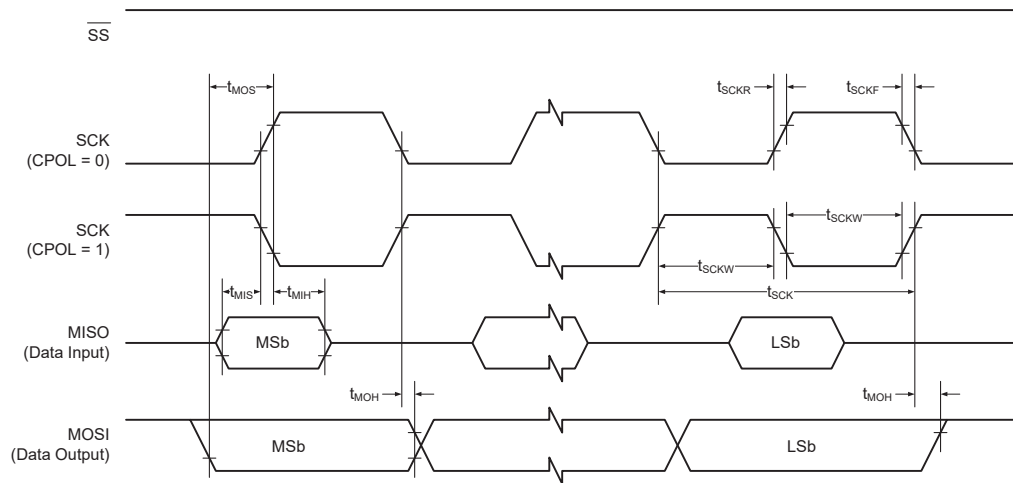

Table 33-17. USART in SPI Host Mode - Timing Characteristics⁽¹⁾

Symbol	Description	Condition	Min.	Typ.	Max.	Unit
f_{SCK}	SCK clock frequency	Host	-	-	10	MHz
t_{SCK}	SCK period	Host	100	-	-	ns
t_{SCKW}	SCK high/low width	Host	-	$0.5 \times t_{SCK}$	-	ns
t_{SCKR}	SCK rise time	Host	-	2.7	-	ns
t_{SCKF}	SCK fall time	Host	-	2.7	-	ns
t_{MIS}	MISO setup to SCK	Host	-	10	-	ns
t_{MIH}	MISO hold after SCK	Host	-	10	-	ns
t_{MOS}	MOSI setup to SCK	Host	-	$0.5 \times t_{SCK}$	-	ns
t_{MOH}	MOSI hold after SCK	Host	-	1.0	-	ns

Note:

1. These parameters are for design guidance only and are not production tested.

33.13 SPI

Figure 33-6. SPI - Timing Requirements in Host Mode

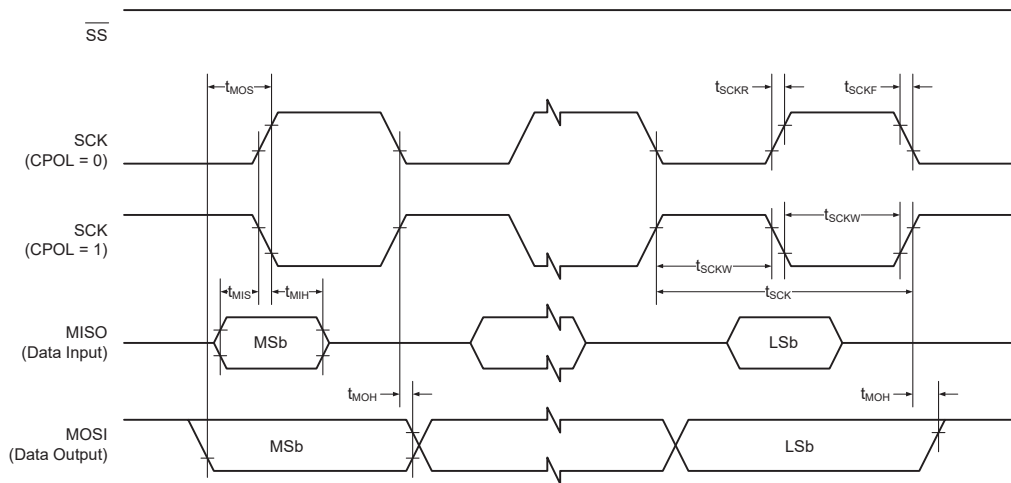

Figure 33-7. SPI - Timing Requirements in Client Mode

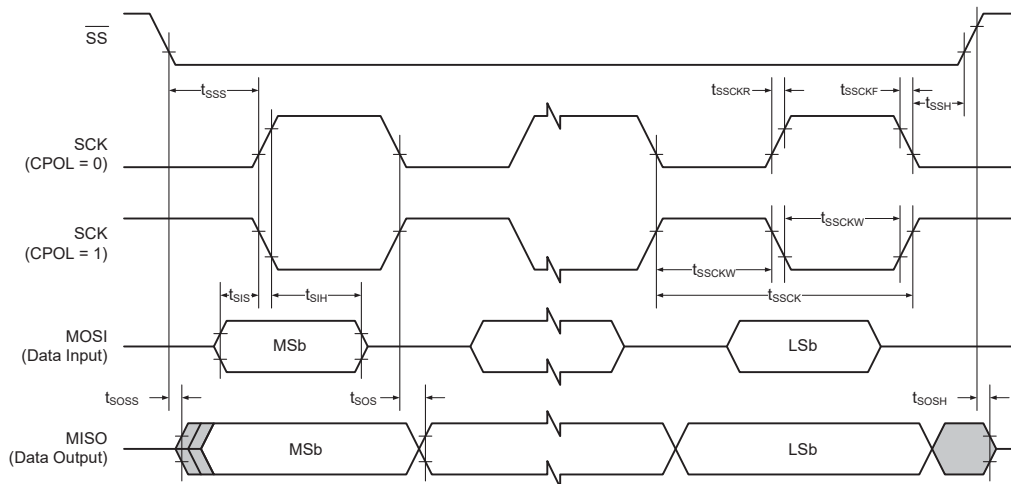

Table 33-18. SPI - Timing Characteristics⁽¹⁾

Symbol	Description	Condition	Min.	Typ.	Max.	Unit
f_{SCK}	SCK clock frequency	Host	-	-	10	MHz
t_{SCK}	SCK period	Host	100	-	-	ns
t_{SCKW}	SCK high/low width	Host	-	$0.5 \times SCK$	-	ns
t_{SCKR}	SCK rise time	Host	-	2.7	-	ns
t_{SCKF}	SCK fall time	Host	-	2.7	-	ns
t_{MIS}	MISO setup to SCK	Host	-	10	-	ns
t_{MIH}	MISO hold after SCK	Host	-	10	-	ns
t_{MOS}	MOSI setup to SCK	Host	-	$0.5 \times SCK$	-	ns
t_{MOH}	MOSI hold after SCK	Host	-	1.0	-	ns
f_{SSCK}	Client SCK clock frequency	Client	-	-	5	MHz

.....continued

Symbol	Description	Condition	Min.	Typ.	Max.	Unit
t_{SSCK}	Client SCK period	Client	$4 \times t_{CLK_PER}$	-	-	ns
t_{SSCKW}	SCK high/low width	Client	$2 \times t_{CLK_PER}$	-	-	ns
t_{SSCKR}	SCK rise time	Client	-	-	1600	ns
t_{SSCKF}	SCK fall time	Client	-	-	1600	ns
t_{SIS}	MOSI setup to SCK	Client	3.0	-	-	ns
t_{SIH}	MOSI hold after SCK	Client	t_{CLK_PER}	-	-	ns
t_{SSS}	SS setup to SCK	Client	21	-	-	ns
t_{SSH}	SS hold after SCK	Client	20	-	-	ns
t_{SOS}	MISO setup to SCK	Client	-	8.0	-	ns
t_{SOH}	MISO hold after SCK	Client	-	13	-	ns
t_{SOSS}	MISO setup after SS low	Client	-	11	-	ns
t_{SOSH}	MISO hold after SS low	Client	-	8.0	-	ns

Note:

1. These parameters are for design guidance only and are not production tested.

33.14 TWI

Figure 33-8. TWI - Timing Requirements

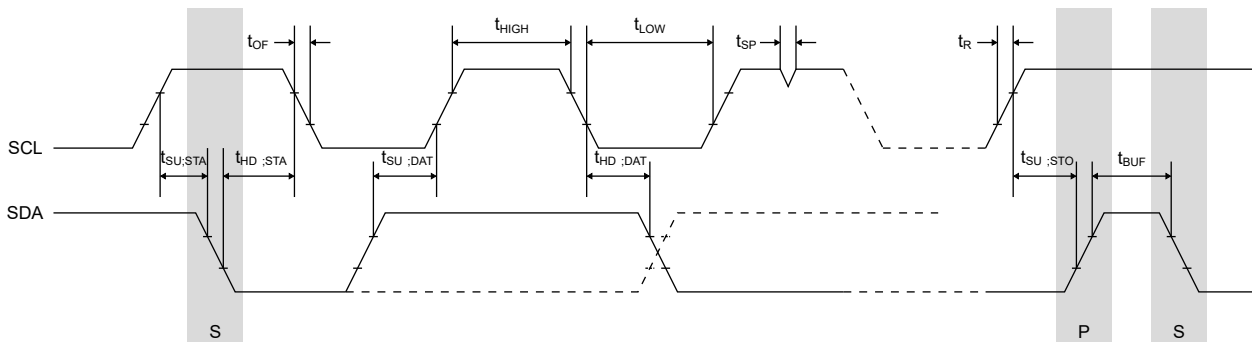

Table 33-19. TWI - Specifications⁽¹⁾

Symbol	Description	Condition	Min.	Typ.	Max.	Unit
f_{SCL}	SCL clock frequency	Max. frequency requires system clock at 10 MHz	0	-	1000	kHz
V_{IH}	Input high voltage		$0.7 \times V_{DD}$	-	-	V
V_{IL}	Input low voltage		-	-	$0.3 \times V_{DD}$	V
V_{HYS}	Hysteresis of Schmitt Trigger inputs		$0.1 \times V_{DD}$		$0.4 \times V_{DD}$	V

ATtiny3224/3226/3227

Electrical Characteristics

.....continued							
Symbol	Description	Condition		Min.	Typ.	Max.	Unit
V _{OL}	Output low voltage	I _{load} = 20 mA, Fast mode+		-	-	0.2 × V _{DD}	V
		I _{load} = 3 mA, Normal mode, V _{DD} > 2V		-	-	0.4V	
		I _{load} = 3 mA, Normal mode, V _{DD} ≤ 2V		-	-	0.2 × V _{DD}	
I _{OL}	Low-level output current	f _{SCL} ≤ 400 kHz, V _{OL} = 0.4V		3	-	-	mA
		f _{SCL} ≤ 1 MHz, V _{OL} = 0.4V		20	-	-	
C _B	Capacitive load for each bus line	f _{SCL} ≤ 100 kHz		-	-	400	pF
		f _{SCL} ≤ 400 kHz		-	-	400	
		f _{SCL} ≤ 1 MHz		-	-	550	
t _R	Rise time for both SDA and SCL	f _{SCL} ≤ 100 kHz		-	-	1000	ns
		f _{SCL} ≤ 400 kHz		20	-	300	
		f _{SCL} ≤ 1 MHz		-	-	120	
t _{OF}	Output fall time from V _{IHmin} to V _{ILmax}	10 pF < capacitance of bus line < 400 pF	f _{SCL} ≤ 100 kHz	-	-	250	ns
			f _{SCL} ≤ 400 kHz	20 × (V _{DD} /5.5V)	-	250	
			f _{SCL} ≤ 1 MHz	20 × (V _{DD} /5.5V)	-	120	
t _{SP}	Spikes suppressed by the input filter			0	-	50	ns
I _L	Input current for each I/O pin	0.1×V _{DD} < V _I < 0.9×V _{DD}		-	-	1	μA
C _I	Capacitance for each I/O pin			-	-	10	pF
R _{P_TWI}	Value of external pull-up resistor	f _{SCL} ≤ 100 kHz		(V _{DD} - V _{OL(max)}) / I _{OL}	-	1000 ns / (0.8473 × C _B)	Ω
		f _{SCL} ≤ 400 kHz		-	-	300 ns / (0.8473 × C _B)	
		f _{SCL} ≤ 1 MHz		-	-	120 ns / (0.8473 × C _B)	
t _{HD;STA}	Hold time (repeated) Start condition	f _{SCL} ≤ 100 kHz		4.0	-	-	μs
		f _{SCL} ≤ 400 kHz		0.6	-	-	
		f _{SCL} ≤ 1 MHz		0.26	-	-	
		Start		-	2.1	-	
		Repeated start		-	3.1	-	T _{SCL}

.....continued

Symbol	Description	Condition	Min.	Typ.	Max.	Unit
t _{LOW}	Low period of SCL Clock	f _{SCL} ≤ 100 kHz	4.7	-	-	μs
		f _{SCL} ≤ 400 kHz	1.3	-	-	
		f _{SCL} ≤ 1 MHz	0.5	-	-	
t _{HIGH}	High period of SCL Clock	f _{SCL} ≤ 100 kHz	4.0	-	-	μs
		f _{SCL} ≤ 400 kHz	0.6	-	-	
		f _{SCL} ≤ 1 MHz	0.26	-	-	
t _{SU;STA}	Setup time for a repeated Start condition	f _{SCL} ≤ 100 kHz	4.7	-	-	μs
		f _{SCL} ≤ 400 kHz	0.6	-	-	
		f _{SCL} ≤ 1 MHz	0.26	-	-	
			-	3	-	T _{SCL}
t _{HD;DAT}	Data hold time	f _{SCL} ≤ 100 kHz	0	-	3.45	μs
		f _{SCL} ≤ 400 kHz	0	-	0.9	
		f _{SCL} ≤ 1 MHz	0	-	0.45	
t _{SU;DAT}	Data setup time	f _{SCL} ≤ 100 kHz	250	-	-	ns
		f _{SCL} ≤ 400 kHz	100	-	-	
		f _{SCL} ≤ 1 MHz	50	-	-	
t _{SU;STO}	Setup time for Stop condition	f _{SCL} ≤ 100 kHz	4	-	-	μs
		f _{SCL} ≤ 400 kHz	0.6	-	-	
		f _{SCL} ≤ 1 MHz	0.26	-	-	
			-	2	-	T _{SCL}
t _{BUF}	Bus free time between a Stop and Start condition	f _{SCL} ≤ 100 kHz	4.7	-	-	μs
		f _{SCL} ≤ 400 kHz	1.3	-	-	
		f _{SCL} ≤ 1 MHz	0.5	-	-	
			-	2	-	T _{SCL}

Note:

1. These parameters are for design guidance only and are not production tested.

Table 33-20. SDA Hold Time^(1,2)

Symbol	Description	Condition	Min.	Typ.	Max.	Unit		
t _{HD;DAT}	Data hold time	Host ⁽³⁾	f _{CLK_PER} = 5 MHz	SDAHOLD = 0x00	-	800	-	ns
				SDAHOLD = 0x01	830	850	950	
				SDAHOLD = 0x02	830	850	950	
				SDAHOLD = 0x03	830	850	1270	
			f _{CLK_PER} = 10 MHz	SDAHOLD = 0x00	-	400	-	
				SDAHOLD = 0x01	430	450	550	
				SDAHOLD = 0x02	430	450	580	
				SDAHOLD = 0x03	430	550	1270	
			f _{CLK_PER} = 20 MHz	SDAHOLD = 0x00	-	200	220	
				SDAHOLD = 0x01	230	250	350	
				SDAHOLD = 0x02	260	450	580	
				SDAHOLD = 0x03	380	600	1270	
t _{HD;DAT}	Data hold time	Client ⁽⁴⁾	All Frequencies	SDAHOLD = 0x00	90	150	220	ns
				SDAHOLD = 0x01	130	200	350	
				SDAHOLD = 0x02	260	400	580	
				SDAHOLD = 0x03	390	550	1270	

Notes:

1. These parameters are for design guidance only and are not covered by production test limits.
2. SDAHOLD is the data hold time after the SCL signal is detected as being low. The actual hold time is, therefore, higher than the configured hold time.
3. For Host mode, the data hold time is whatever is largest of the following:
 - 4 × t_{CLK_PER} + 50 ns (typical)
 - SDAHOLD configuration + SCL filter delay
4. For Client mode, the hold time is given by:
 - SDAHOLD configuration + SCL filter delay

33.15 VREF

Table 33-21. Internal Voltage Reference Characteristics⁽¹⁾

Symbol	Description	Min.	Typ.	Max.	Unit
t _{start}	Start-up time	-	25	-	μs
V _{DD}	Power supply voltage range for 1V024	1.8	-	5.5	V
	Power supply voltage range for 2V048	2.6	-	5.5	
	Power supply voltage range for 2V500	3.0	-	5.5	
	Power supply voltage range for 4V096	4.6	-	5.5	

Note:

1. These parameters are for design guidance only and are not production tested.

Table 33-22. ADC Internal Voltage Reference Characteristics⁽¹⁾

Symbol ⁽²⁾	Description	Condition	Min.	Typ.	Max.	Unit
2V048	Internal reference voltage	$V_{DD} = [1.8, 5.5]V$ $T = [0, 85]^{\circ}C$	-2.0		2.0	%
1V024 2V500 4V096	Internal reference voltage	$V_{DD} = [1.8, 5.5]V$ $T = [0, 85]^{\circ}C$	-3.0		3.0	
1V024 2V048 2V500 4V096	Internal reference voltage	$V_{DD} = [1.8, 5.5]V$ $T = [-40, 125]^{\circ}C$	-5.0		5.0	

Notes:

1. These values are based on characterization and not covered by production test limits.
2. The symbols xVxxx refer to the respective values of the REFSEL bit field in the ADC0.CTRLC register.

Table 33-23. AC Internal Voltage Reference Characteristics⁽¹⁾

Symbol ⁽²⁾	Description	Condition	Min.	Typ.	Max.	Unit
1V024 2V048 2V500 4V096	Internal reference voltage	$V_{DD} = [1.8, 5.5]V$ $T = [-40, 125]^{\circ}C$	-4.5		4.5	%

Notes:

1. These values are based on characterization and not covered by production test limits.
2. The symbols xVxxx refer to the respective values of the AC0REFSEL bit field in the VREF.CTRLA register.

33.16 ADC

Operating conditions:

- $T_A = [-40, 125]^{\circ}C$
- Sample rate defined for SAMPDUR = 0x02 with ADC in Free-Running mode
- Applies for all allowed combinations of VREF selections and sample rates, unless otherwise specified
- Characteristics are identical with and without PGA enabled, unless otherwise specified

Table 33-24. Power Supply, Reference and Input Range

Symbol	Description	Conditions	Min.	Typ.	Max.	Unit
V_{DD}	Supply Voltage		1.8	-	5.5	V
V_{REF}	Reference voltage	REFSEL = Internal Reference	1.024	-	$V_{DD} - 0.5$	
		REFSEL = External Reference	1	-	5.5	
		REFSEL = V_{DD}	1.8	-	5.5	
C_{IN}	Input capacitance	PGA disabled	-	8	-	pF
		PGA enabled	-	7	-	
R_{IN}	Input resistance		-	10	-	k Ω
V_{IN}	Input voltage range	Single-ended mode	0	-	V_{REF}	V
		Differential mode	-0.1	-	$V_{DD} + 0.1$	

Table 33-25. Clock and Timing Characteristics

Symbol	Description	Conditions	Min.	Typ.	Max.	Unit	
f _{CLK_ADC}	Conversion rate	PGA disabled	REFSEL = Internal Reference	-	-	187	ksp/s
			REFSEL = External Reference	-	-	375	
			REFSEL = V _{DD}	-	-	-	
		PGA enabled	REFSEL = Internal Reference	-	-	107	
			REFSEL = External Reference	-	-	181	
			REFSEL = V _{DD}	-	-	-	
CLK_ADC	ADC clock frequency	REFSEL = Internal Reference	300	-	3000	kHz	
		REFSEL = External Reference	300	-	6000		
		REFSEL = V _{DD}	-	-	-		
T _S	Sampling time	PGA disabled	0.5	-	255.5	CLK_ADC cycles	
		PGA enabled	1	-	256		

Table 33-26. Accuracy Characteristics External Reference⁽¹⁾

Symbol	Description	Conditions	Min.	Typ.	Max.	Unit
Res	Resolution		-	-	12	bit
E _{INL}	Integral nonlinearity	V _{DD} = 3.0V V _{REF} = 2.048V CLK_ADC = 2.5 MHz Differential mode	-2.0	0.8	2.0	LSb
E _{DNL}	Differential nonlinearity		-0.9	0.8	1.4	
E _{OFF}	Offset error		-28	1.5	28	
E _{GAIN}	Gain error		-2.1	0.6	2.1	
E _T	Total unadjusted error		-	5	21	

Note:

1. These values are based on characterization and are not covered by production test limits.

Table 33-27. Accuracy Characteristics Internal Reference⁽¹⁾

Symbol	Description	Conditions	Min.	Typ.	Max.	Unit
Res	Resolution		-	-	12	bit
E _{INL}	Integral nonlinearity	V _{DD} = 3.0V V _{REF} = 2.048V CLK_ADC = 2.5 MHz Differential mode	-2.3	1	2.3	LSb
E _{DNL}	Differential nonlinearity		-0.9	1	1.6	
E _{OFF}	Offset error		-28	1.5	28	
E _{GAIN}	Gain error		-81	7	81	
E _T	Total unadjusted error		-	10	42	

Note:

1. These values are based on characterization and are not covered by production test limits.

Table 33-28. Accuracy Characteristics with PGA Enabled⁽¹⁾

Symbol	Description	Conditions	Min.	Typ.	Max.	Unit
N _{RMS}	Input Noise	PGA Gain = 1V/V	-	32	-	μV _{RMS}
		PGA Gain = 2V/V	-	63	-	
		PGA Gain = 4V/V	-	125	-	
		PGA Gain = 8V/V	-	250	-	
		PGA Gain = 16V/V	-	500	-	
E _{GAIN}	Gain error V _{DD} = 3.0V	PGA Gain = 1V/V	-0.4	-0.2	0.4	%
		PGA Gain = 2V/V	-0.5	-0.2	0.5	
		PGA Gain = 4V/V	-0.7	-0.3	0.7	
		PGA Gain = 8V/V	-1.2	-0.6	1.2	
		PGA Gain = 16V/V	-1.7	-0.8	1.7	

Note:

1. These values are based on characterization and are not covered by production test limits.

33.17 TEMPSENSE

Operating Conditions:

- V_{DD} = 3V
- T_A = 25°C, unless otherwise specified

Table 33-29. Temperature Sensor, Accuracy Characteristics

Symbol	Description	Condition	Min.	Typ.	Max.	Unit
V _{DD}	Supply voltage		1.8	-	5.5	V
T _{ACC}	Sensor accuracy ^(1,2)	T _A = 25°C	-	+4.5	-	°C
T _{RES}	Conversion resolution	10 bits	-	0.55	-	°C
t _{CONV}	Conversion time	1 MHz ADC clock	-	13	-	μs

Notes:

1. These values are based on characterization and not covered by production test limits.
2. Characteristics over temperature can be found in the *Typical Characteristics* section.

33.18 AC

Table 33-30. Analog Comparator Characteristics, Low-Power Mode Disabled

Symbol	Description	Condition	Min.	Typ.	Max.	Unit
V _{IN}	Input voltage		-0.2	-	V _{DD}	V
V _{OFF}	Input offset voltage	0.7V < V _{IN} < (V _{DD} - 0.7V)	-20	2.0	+20	mV
		V _{IN} = [-0.2V, V _{DD}]	-40	5.0	+40	
I _L	Input leakage current		-	5	-	nA
T _{START}	Start-up time		-	1.3	-	μs

.....continued

Symbol	Description	Condition	Min.	Typ.	Max.	Unit
V _{HYS}	Hysteresis	HYSMODE = 0x0	-	0	-	mV
		HYSMODE = 0x1	-	10	-	
		HYSMODE = 0x2	-	30	-	
		HYSMODE = 0x3	-	55	-	
t _{PD}	Propagation delay	25 mV Overdrive, V _{DD} ≥ 2.7V	-	50	-	ns

Table 33-31. Analog Comparator Characteristics, Low-Power Mode Enabled

Symbol	Description	Condition	Min.	Typ.	Max.	Unit
V _{IN}	Input voltage		-0.2	-	V _{DD}	V
V _{OFF}	Input offset voltage	0.7V < V _{IN} < (V _{DD} - 0.7V)	-30	2.5	+30	mV
		V _{IN} = [0V, V _{DD}]	-50	8.0	+50	
I _L	Input leakage current		-	5	-	nA
T _{START}	Start-up time		-	1.3	-	μs
V _{HYS}	Hysteresis	HYSMODE = 0x0	-	0	-	mV
		HYSMODE = 0x1	-	10	-	
		HYSMODE = 0x2	-	40	-	
		HYSMODE = 0x3	-	80	-	
t _{PD}	Propagation delay	25 mV overdrive, V _{DD} ≥ 2.7V	-	150	-	ns

33.19 UPDI

Figure 33-9. UPDI Enable Sequence (1)

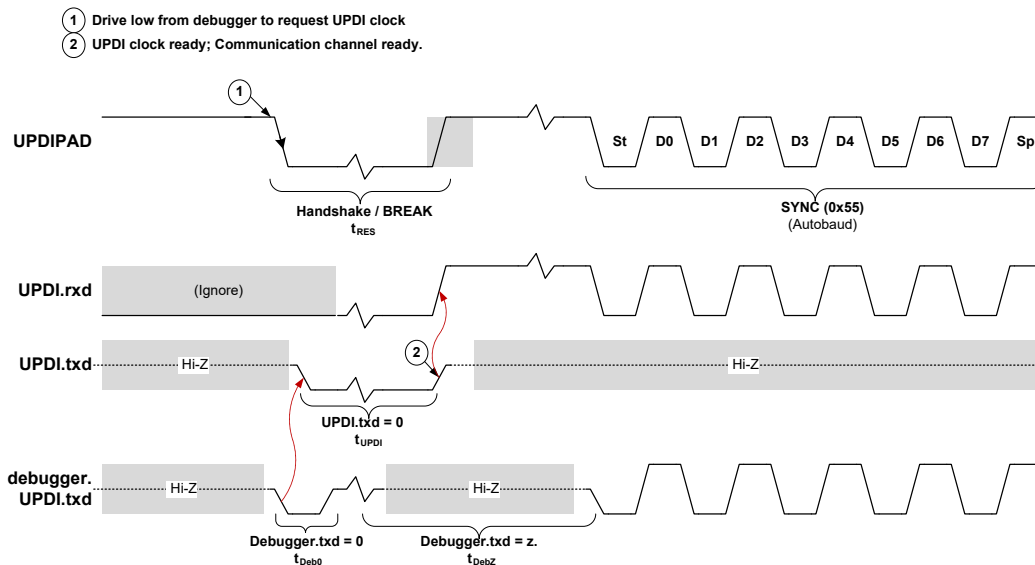

Table 33-32. UPDI Timing⁽¹⁾

Symbol	Description	Min.	Max.	Unit
T _{RES}	Duration of Handshake/Break on RESET	10	200	μs
T _{UPDI}	Duration of UPDI.txd = 0	10	200	μs
T _{Deb0}	Duration of Debugger.txd = 0	0.2	1	μs
T _{DebZ}	Duration of Debugger.txd = z	200	14000	μs

Note:

1. These parameters are for design guidance only and are not covered by production test limits.

Table 33-33. UPDI Max. Bit Rates vs. VDD⁽¹⁾

Symbol	Description	Condition	Max	Unit
f _{UPDI}	UPDI baud rate	V _{DD} = [1.8, 5.5]V T _A = [0, 50]°C	225	kbps
		V _{DD} = [2.2, 5.5]V T _A = [0, 50]°C	450	kbps
		V _{DD} = [2.7, 5.5]V T _A = [0, 50]°C	0.9	Mbps

Note:

1. These parameters are for design guidance only and are not covered by production test limits.

33.20 Programming Time

See the table below for typical programming times for Flash and EEPROM.

Table 33-34. Programming Times

Symbol	Typical Programming Time
Page Buffer Clear (PBC)	Seven CLK_CPU cycles
Page Write (WP)	2 ms
Page Erase (ER)	2 ms
Page Erase-Write (ERWP)	4 ms
Chip Erase with UDPI	40 ms
EEPROM Erase	4 ms

34. Typical Characteristics

34.1 Power Consumption

34.1.1 Active Supply Current

Figure 34-1. Active Supply Current vs. Frequency (1-20 MHz) at T = 25°C (EXTCLK)

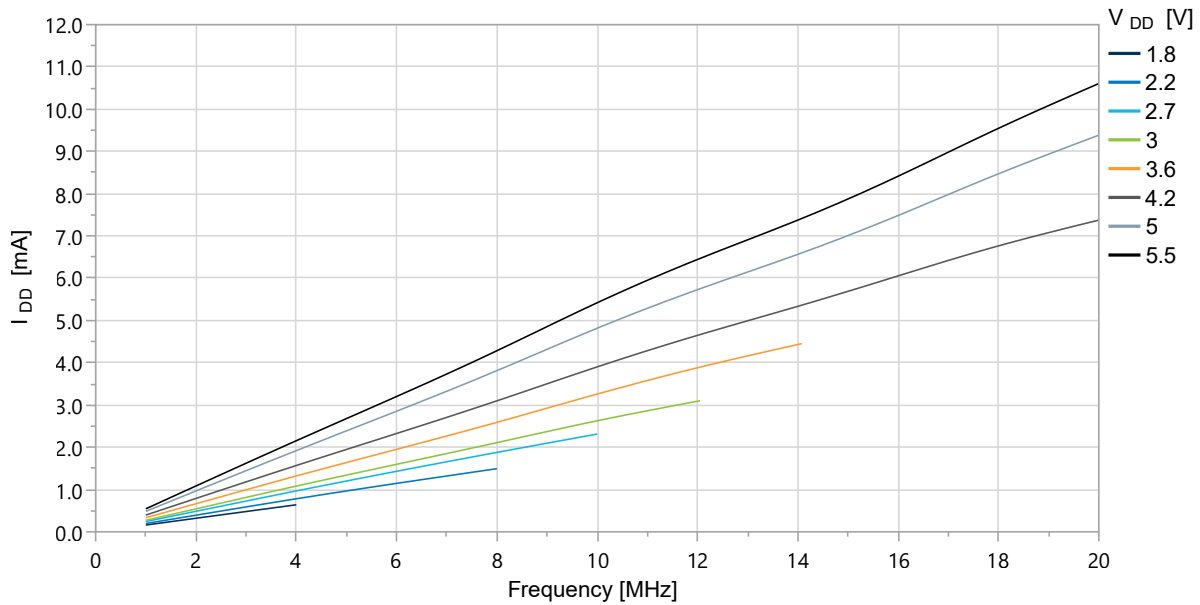

Figure 34-2. Active Supply Current vs. Frequency (0.1-1.0 MHz) at T = 25°C (EXTCLK)

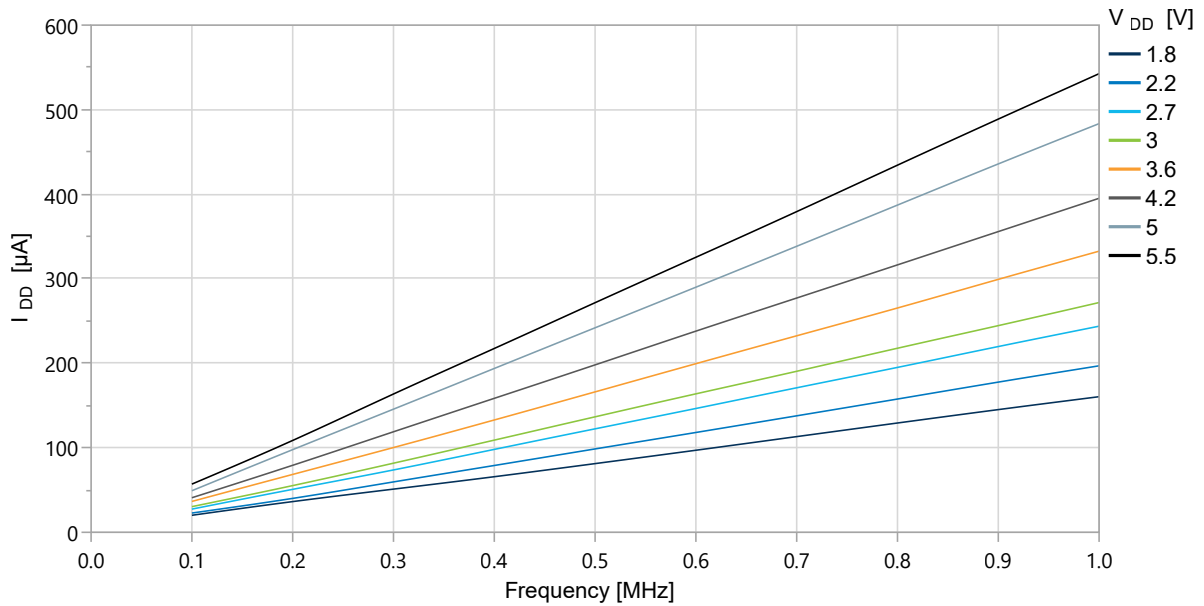

Figure 34-3. Active Supply Current vs. Temperature (f = 20 MHz OSC20M)

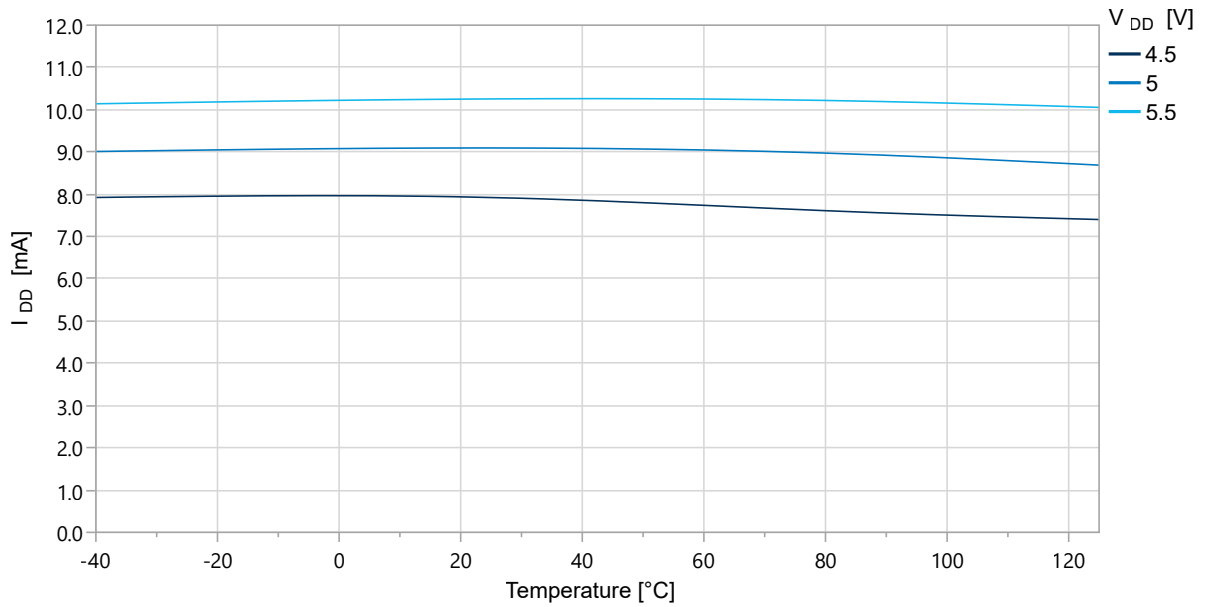
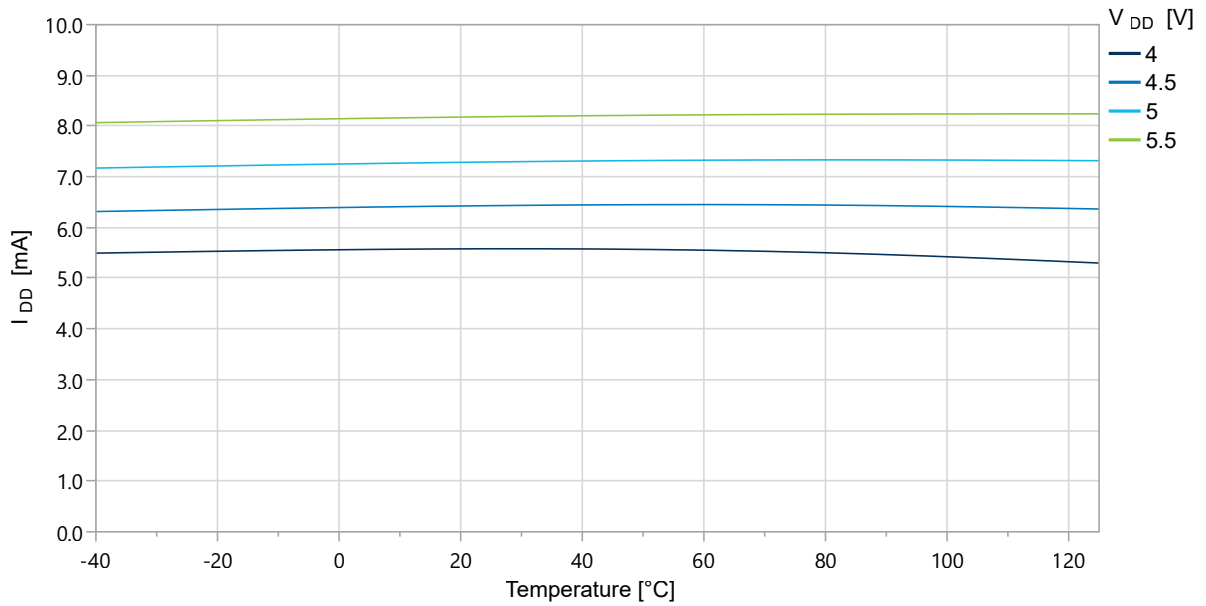

Figure 34-4. Active Supply Current vs. Temperature (f = 16 MHz OSC20M)



ATtiny3224/3226/3227

Typical Characteristics

Figure 34-5. Active Supply Current vs. V_{DD} ($f = [1.25, 20]$ MHz OSC20M) at $T = 25^\circ\text{C}$

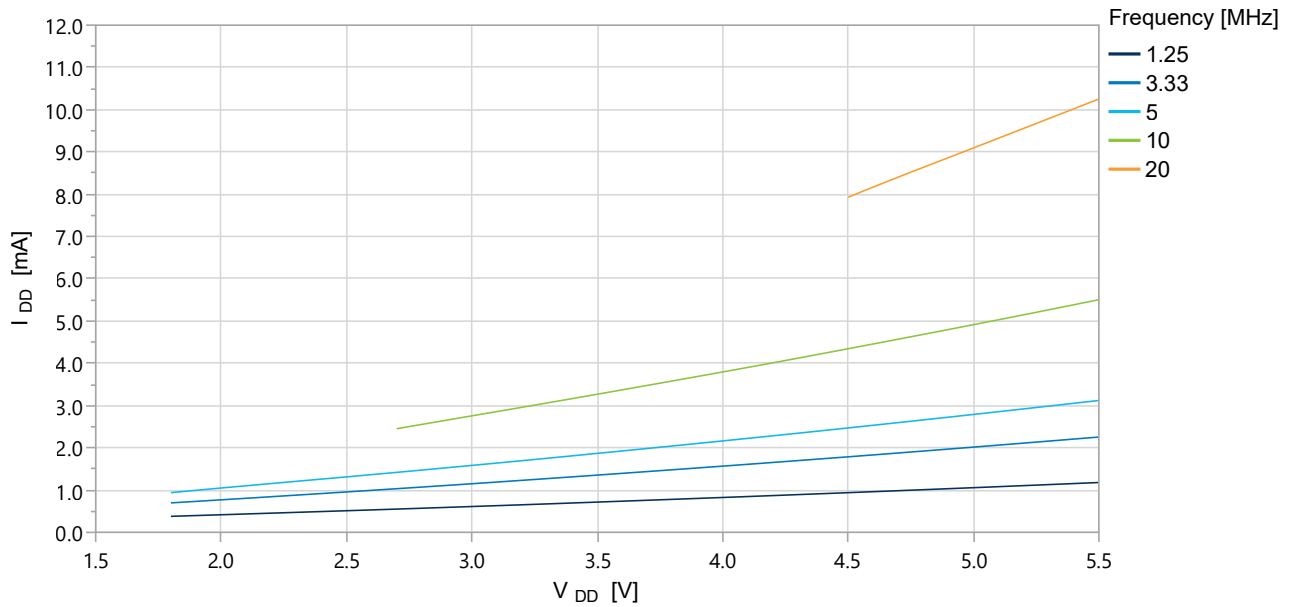

Figure 34-6. Active Supply Current vs. V_{DD} ($f = [1, 16]$ MHz OSC20M) at $T = 25^\circ\text{C}$

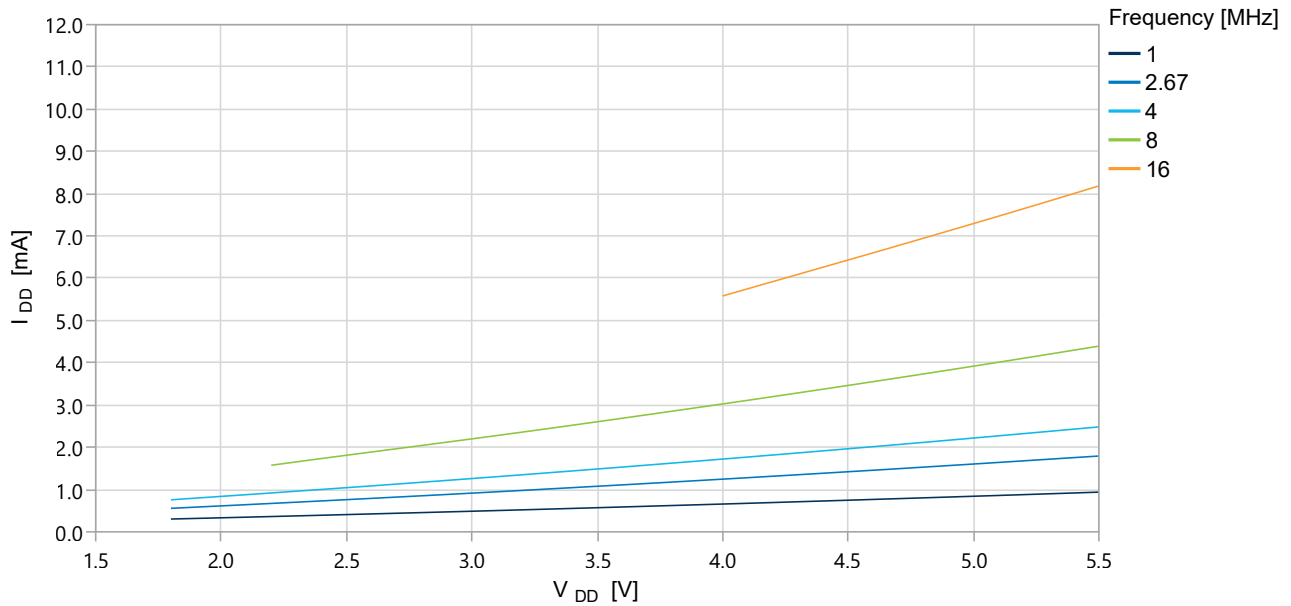
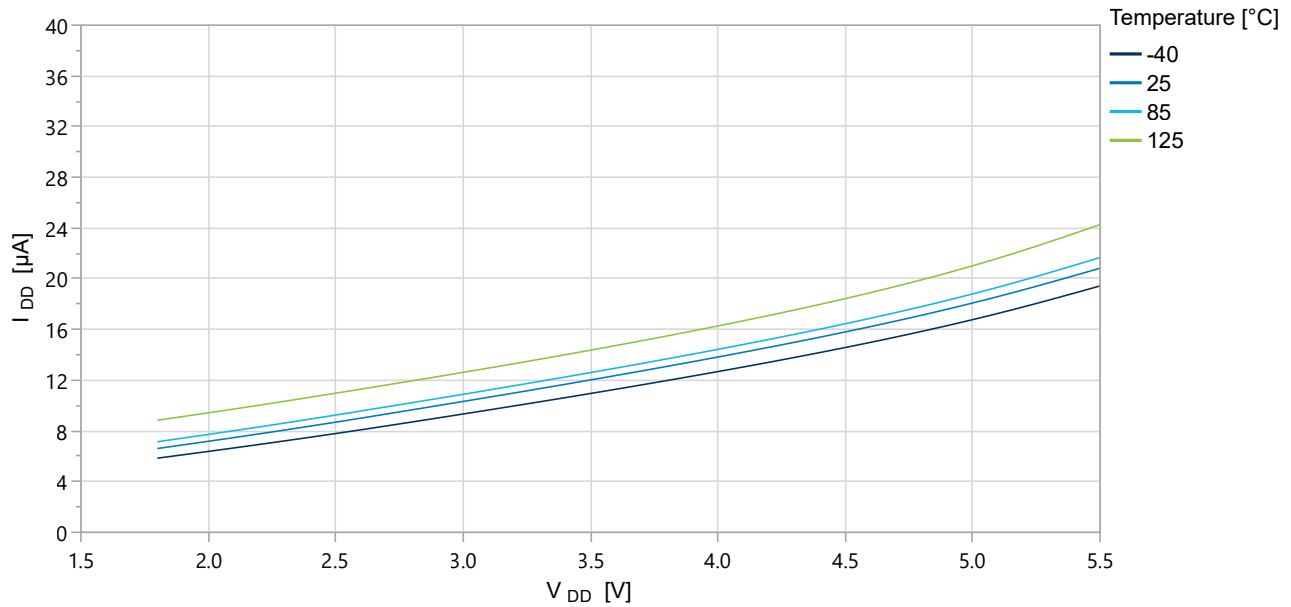

Figure 34-7. Active Supply Current vs. V_{DD} ($f = 32 \text{ kHz OSCULP32K}$)



34.1.2 Idle Supply Current

Figure 34-8. Idle Supply Current vs. Frequency (1-20 MHz) at $T = 25^\circ\text{C}$ (EXTCLK)

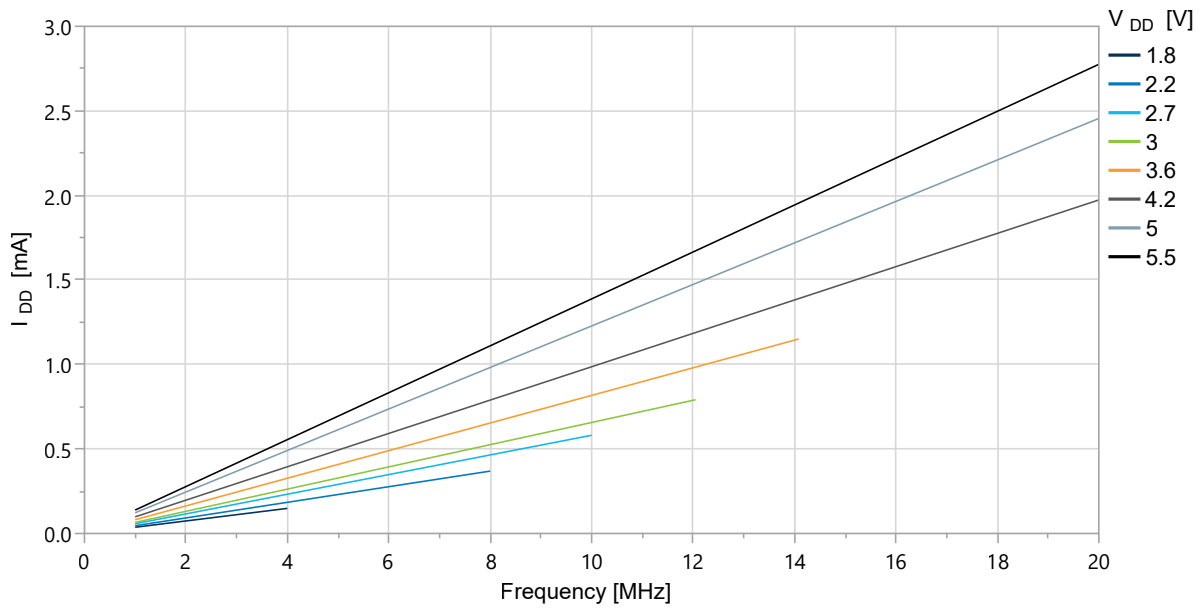

Figure 34-9. Idle Supply Current vs. Frequency [0.1, 1.0] MHz at T = 25°C (EXTCLK)

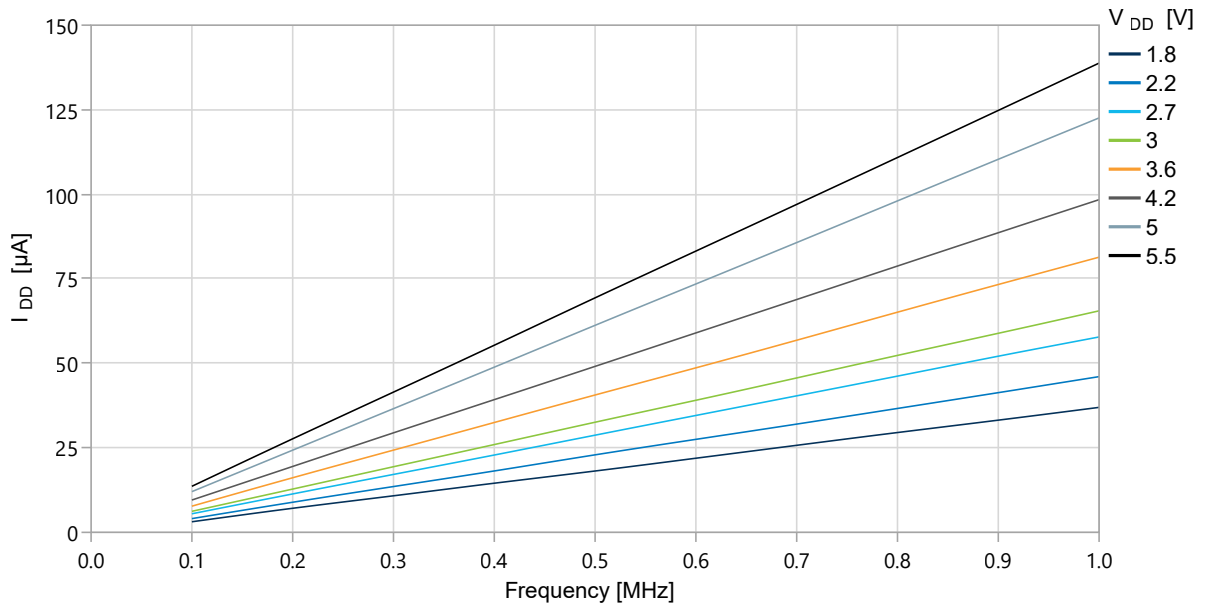

Figure 34-10. Idle Supply Current vs. Temperature (f = 20 MHz OSC20M)

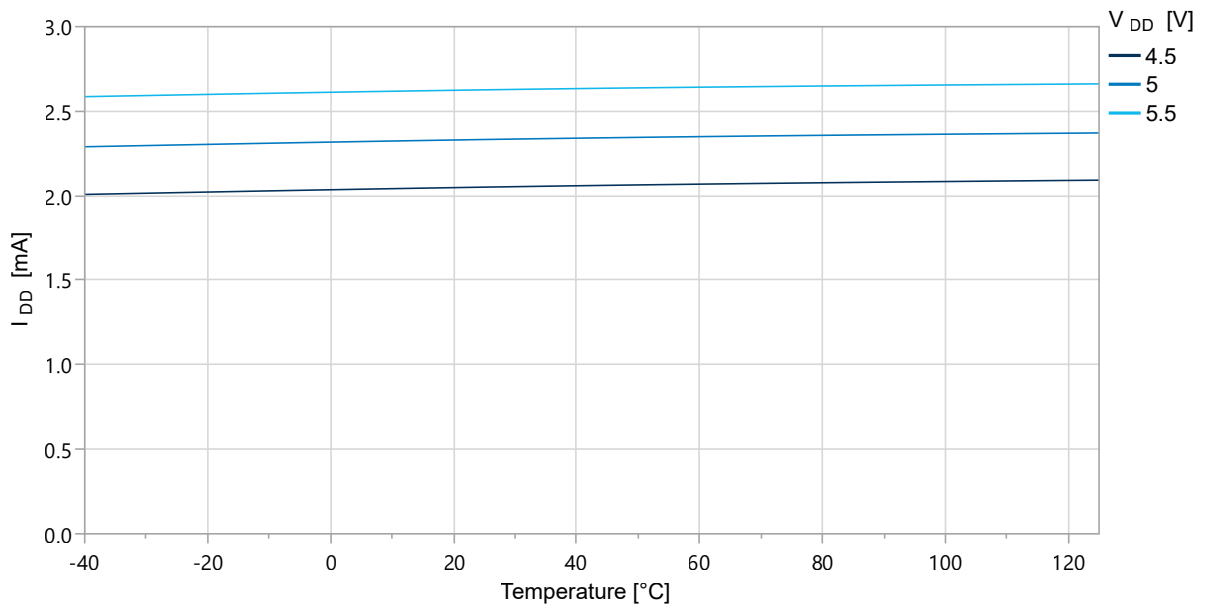

Figure 34-11. Idle Supply Current vs. Temperature (f = 16 MHz OSC20M)

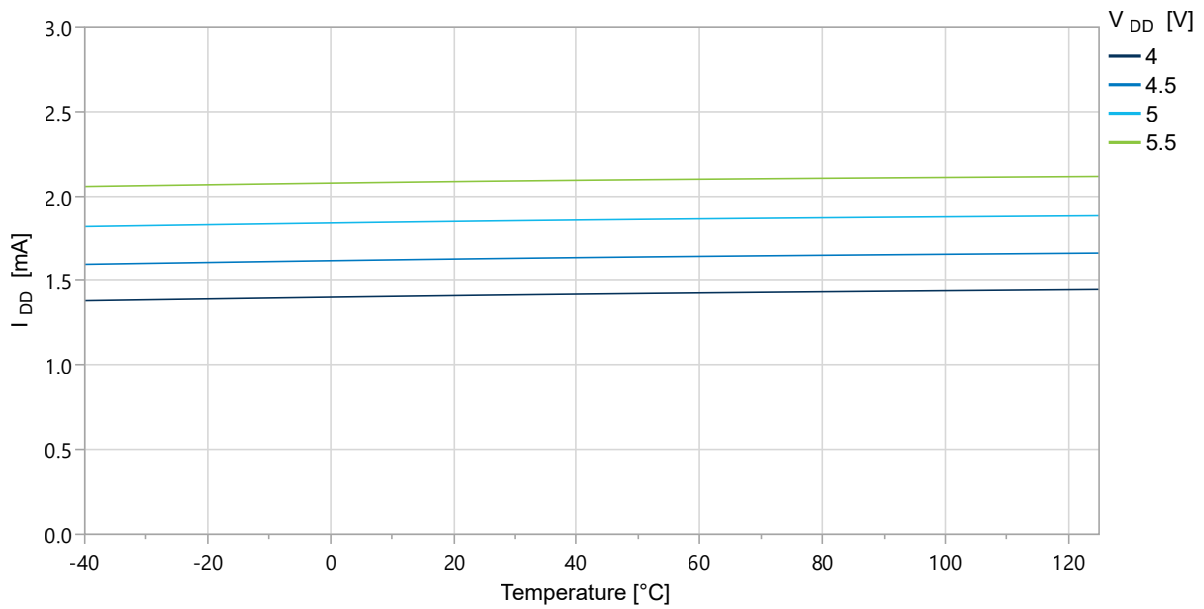
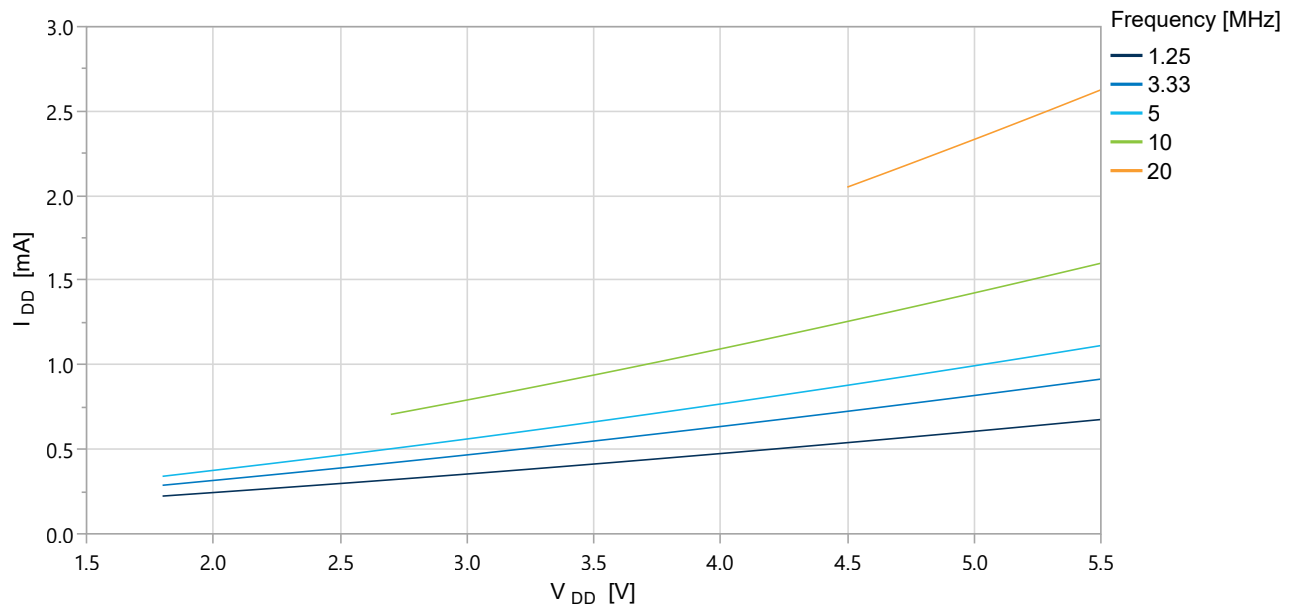

Figure 34-12. Idle Supply Current vs. V_{DD} (f = [1.25, 20] MHz OSC20M) at T = 25 $^{\circ}C$



ATtiny3224/3226/3227

Typical Characteristics

Figure 34-13. Idle Supply Current vs. V_{DD} (f = [1, 16] MHz OSC20M) at T = 25 °C

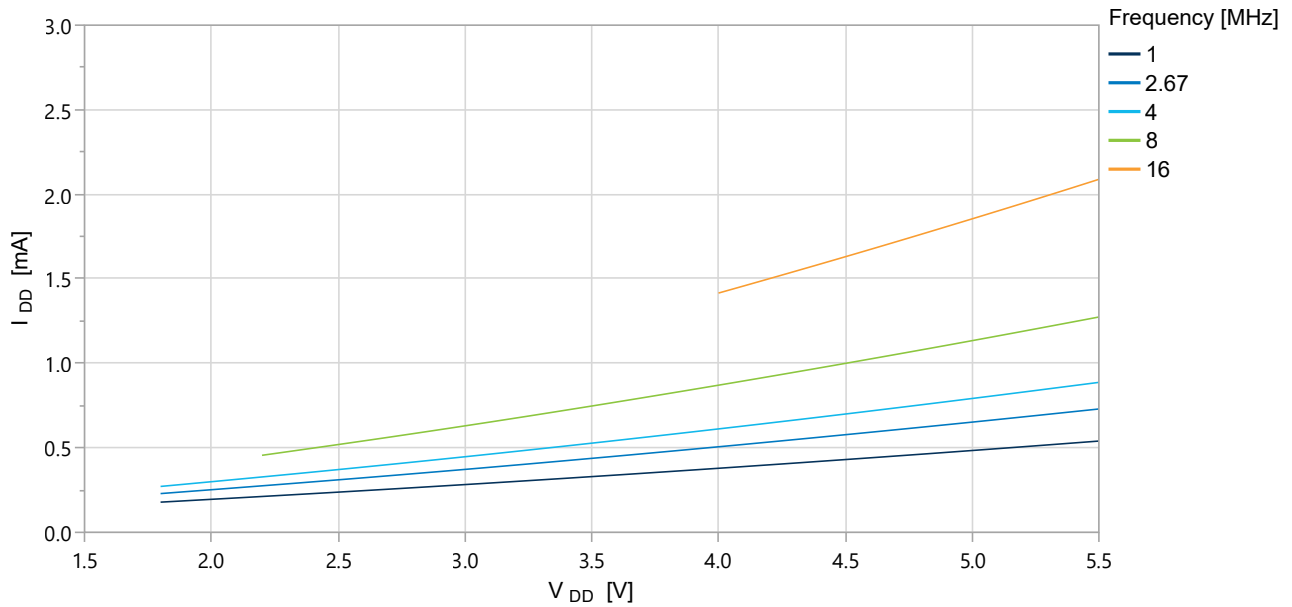
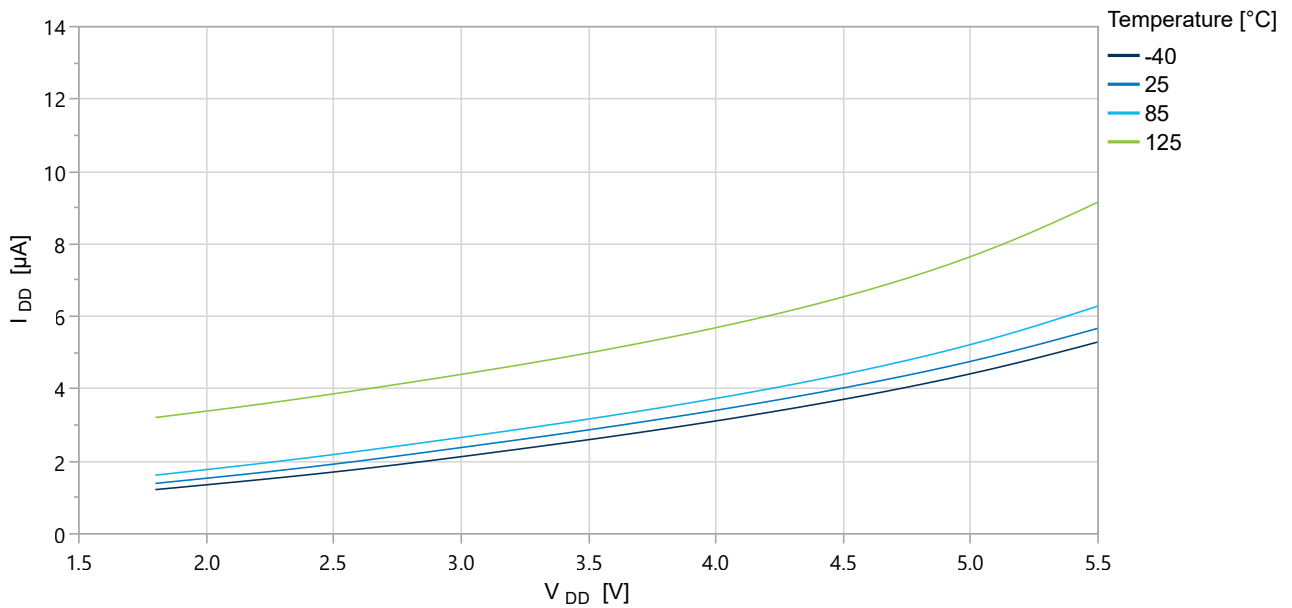

Figure 34-14. Idle Supply Current vs. V_{DD} (f = 32 kHz OSCULP32K)



34.1.3 Standby Supply Current

Figure 34-15. Idle Supply Current vs. V_{DD} (RTC Running with External 32.768 kHz Oscillator)

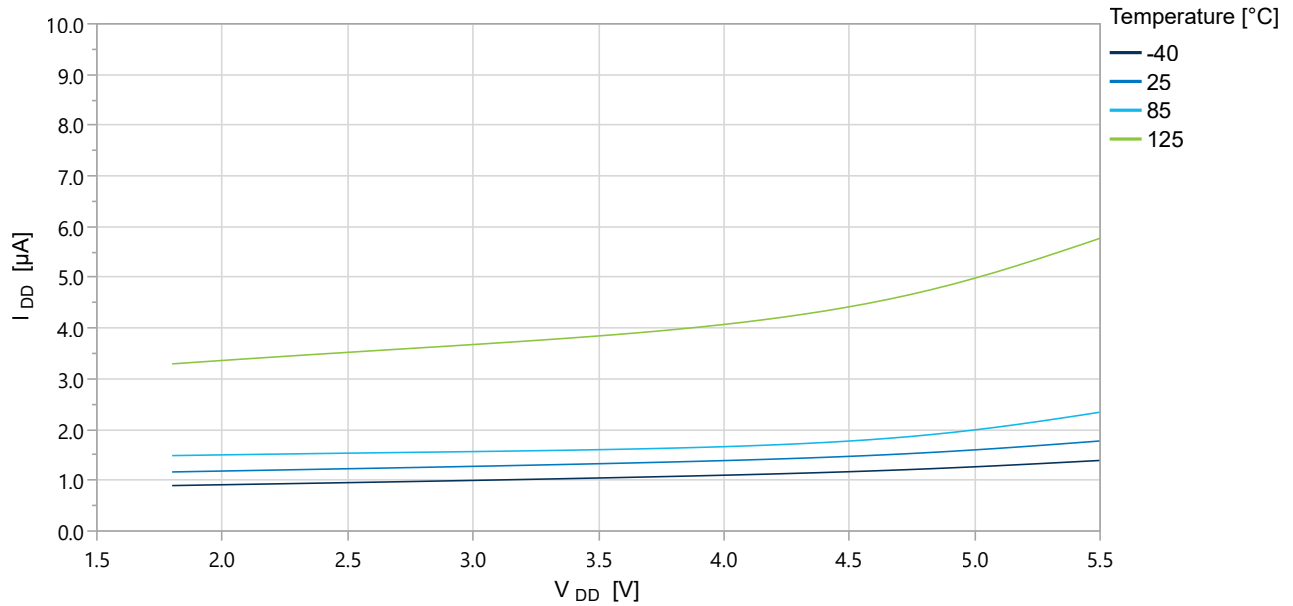

Figure 34-16. Standby Supply Current vs. V_{DD} (RTC Running with Internal OSCULP32K)

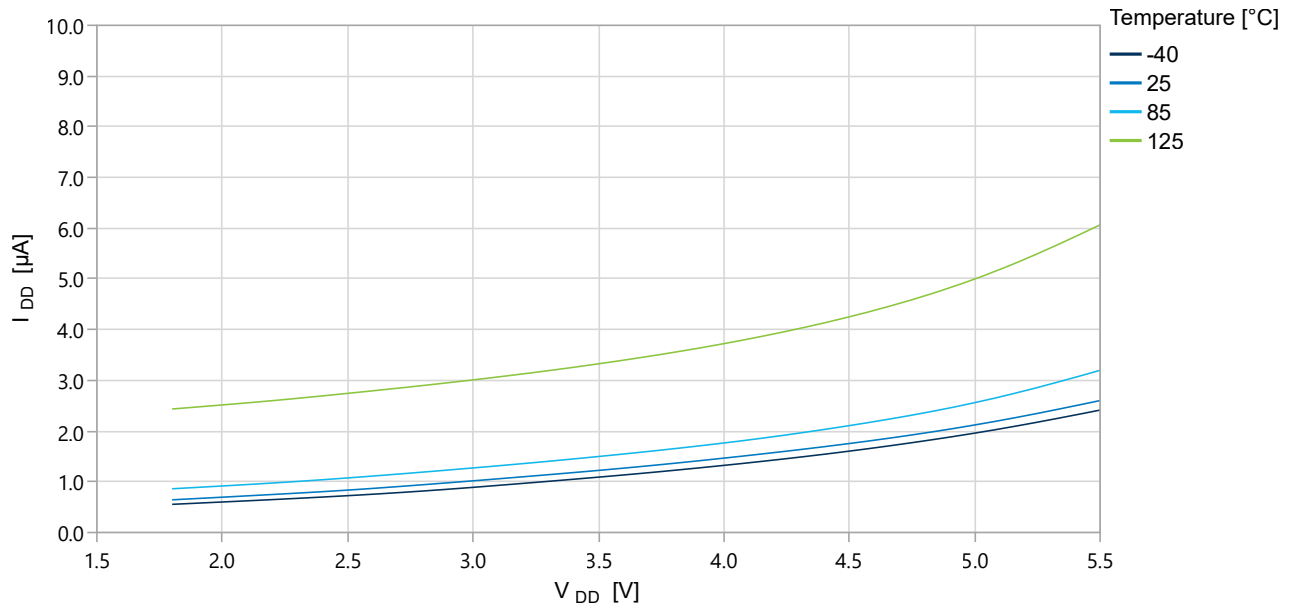

Figure 34-17. Standby Supply Current vs. V_{DD} (Sampled BOD Running at 1 kHz)

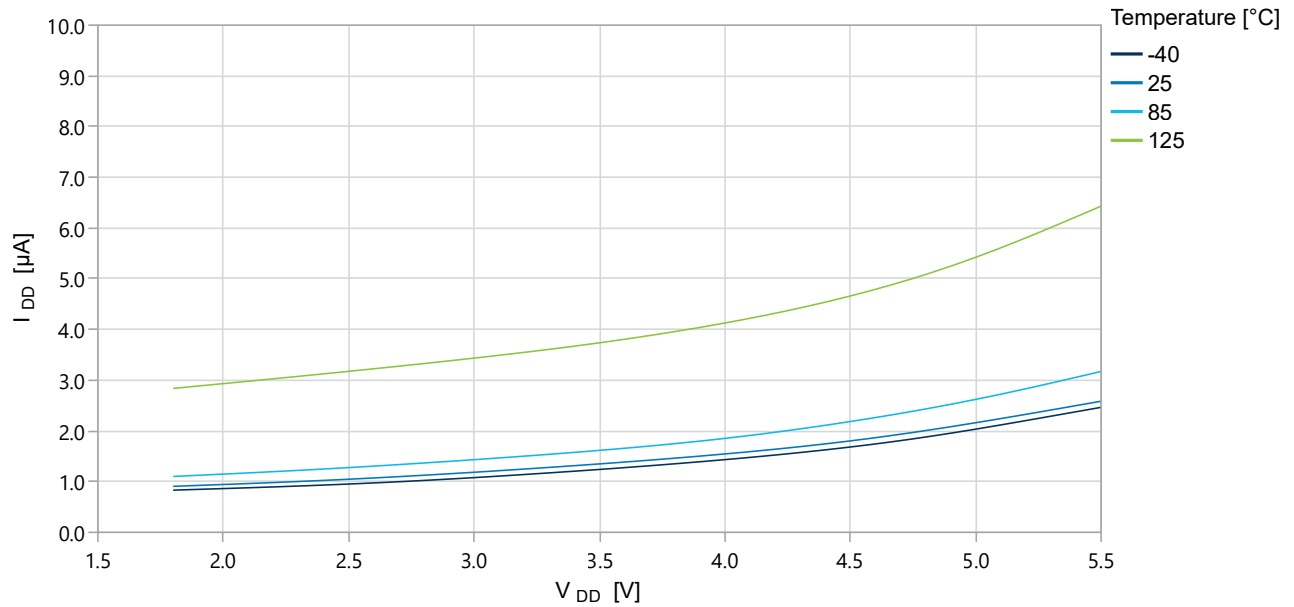
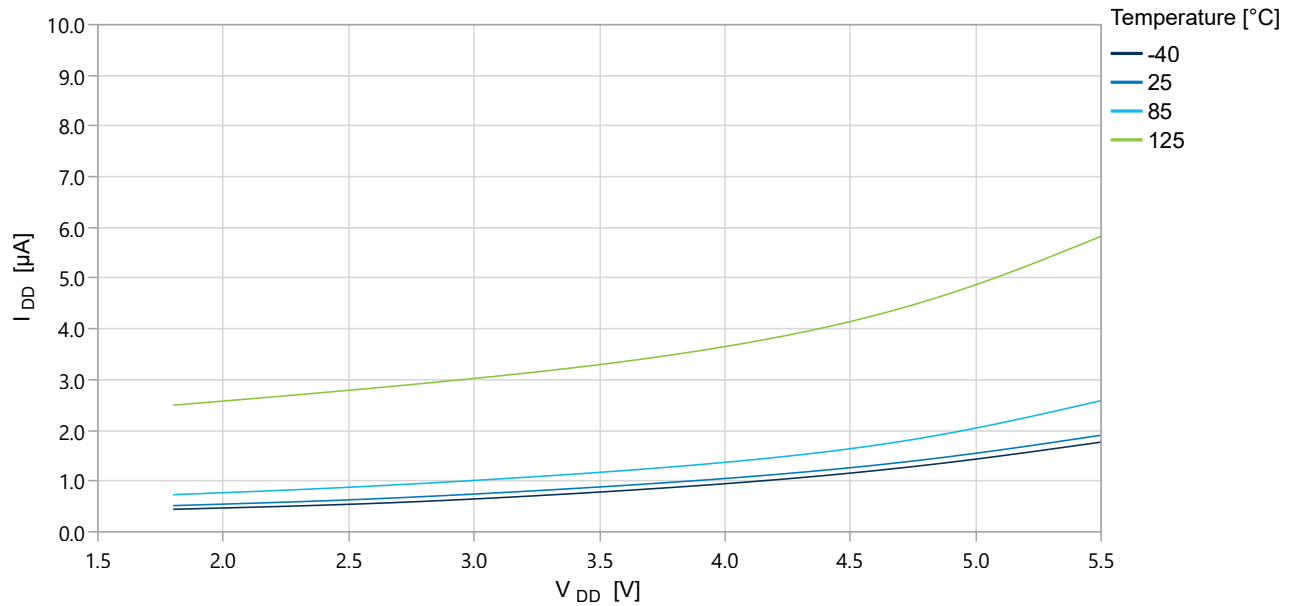

Figure 34-18. Standby Supply Current vs. V_{DD} (Sampled BOD Running at 125 Hz)



34.1.4 Power Down Supply Current

Figure 34-19. Power Down Supply Current vs. Temperature (All Functions Disabled)

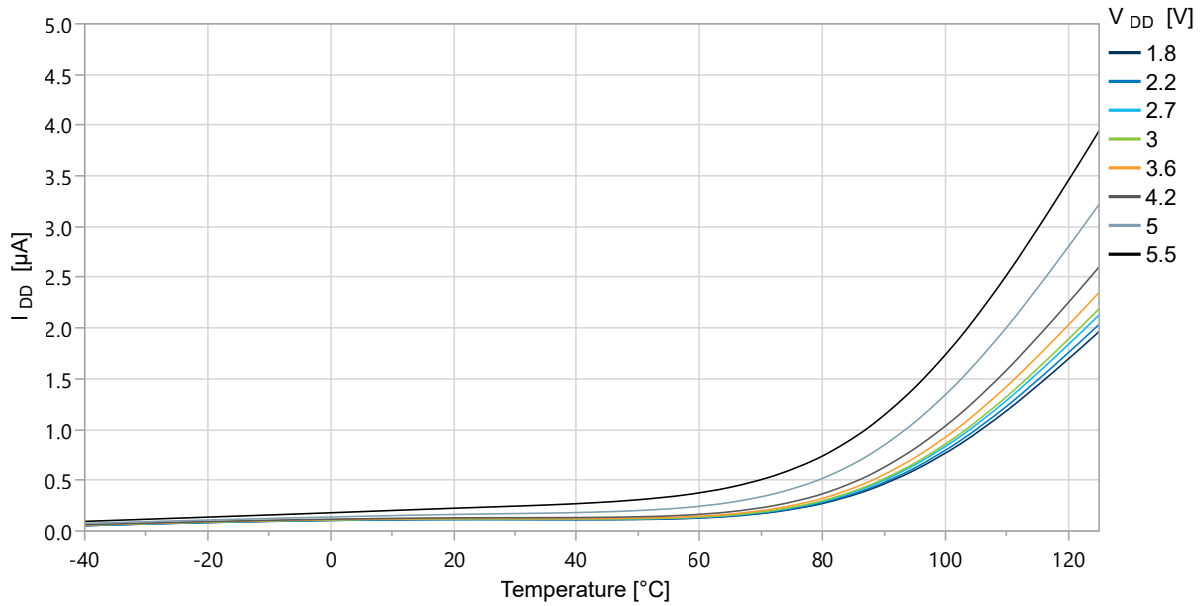
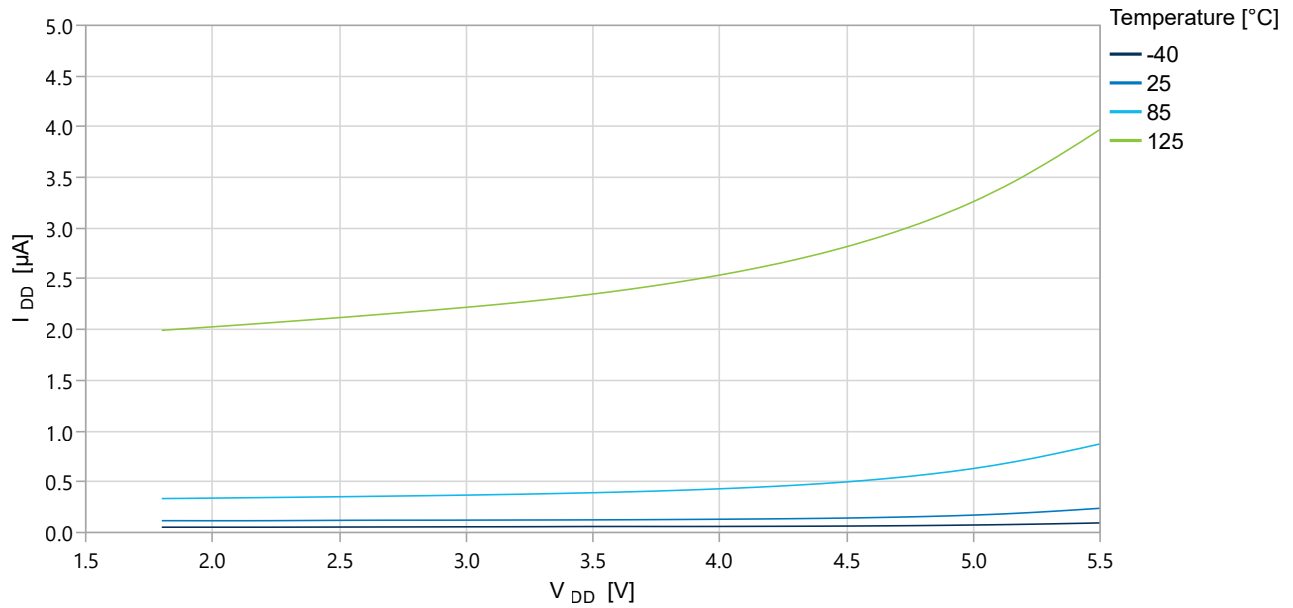
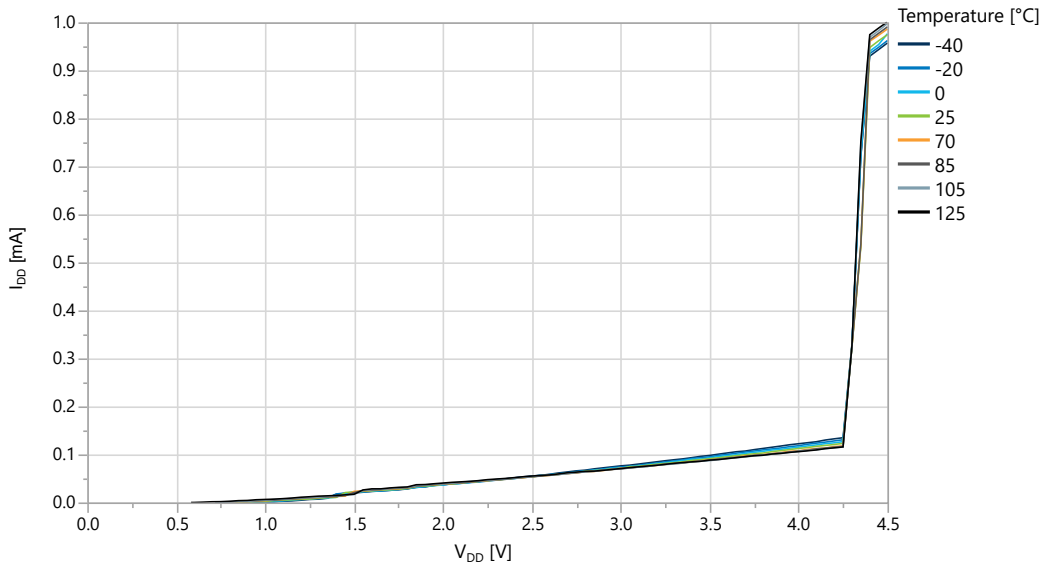

Figure 34-20. Power Down Supply Current vs. V_{DD} (All Functions Disabled)



34.1.5 Power on Supply Currents

Figure 34-21. Power-on Supply Current vs. V_{DD} (BOD Enabled at 4.3V Level)



34.2 GPIO

34.2.1 GPIO Input Characteristics

Figure 34-22. I/O Pin Input Hysteresis vs. V_{DD}

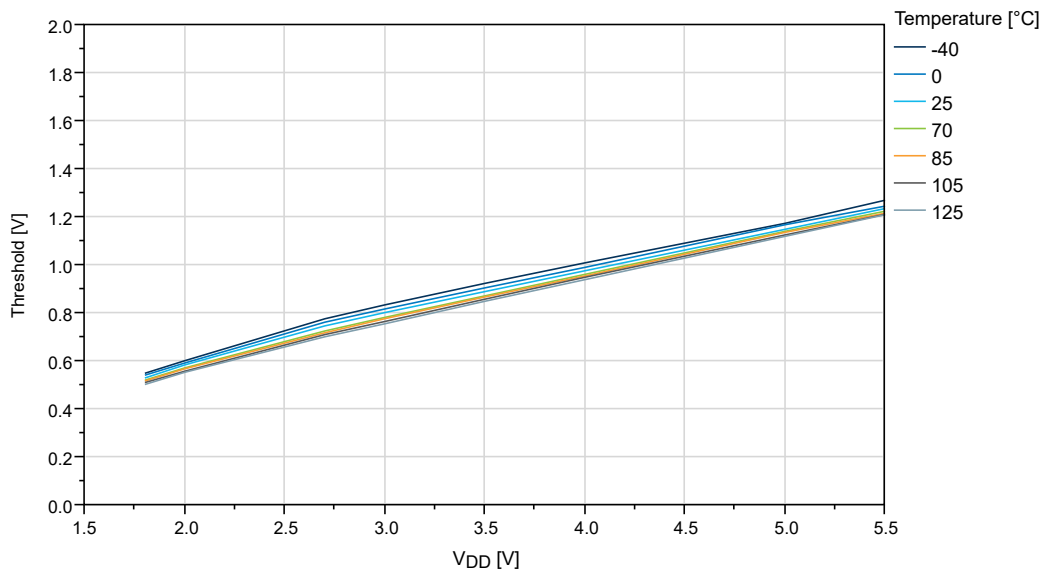

Figure 34-23. I/O Pin Input Threshold Voltage vs. V_{DD} ($T = 25^{\circ}\text{C}$)

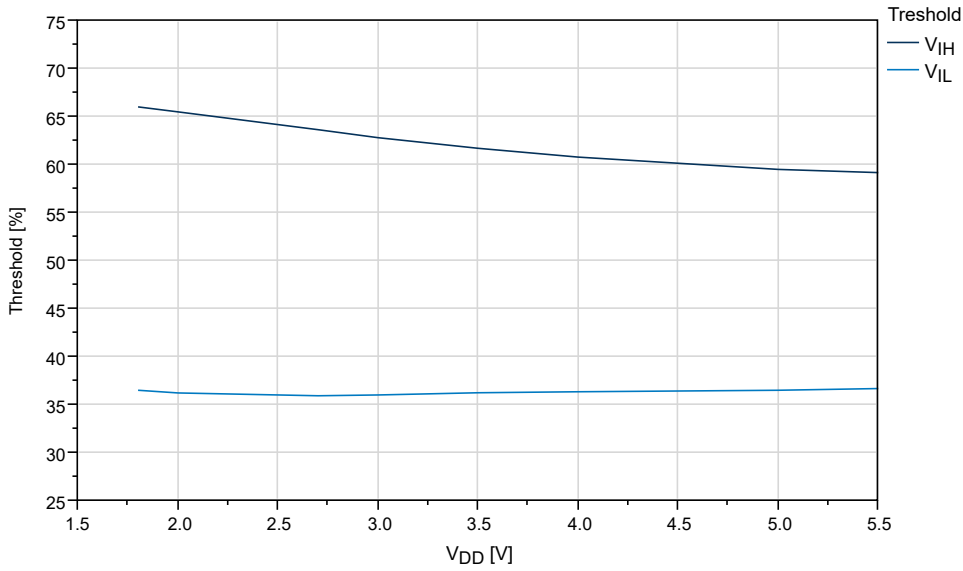

Figure 34-24. I/O Pin Input Threshold Voltage vs. V_{DD} (V_{IH})

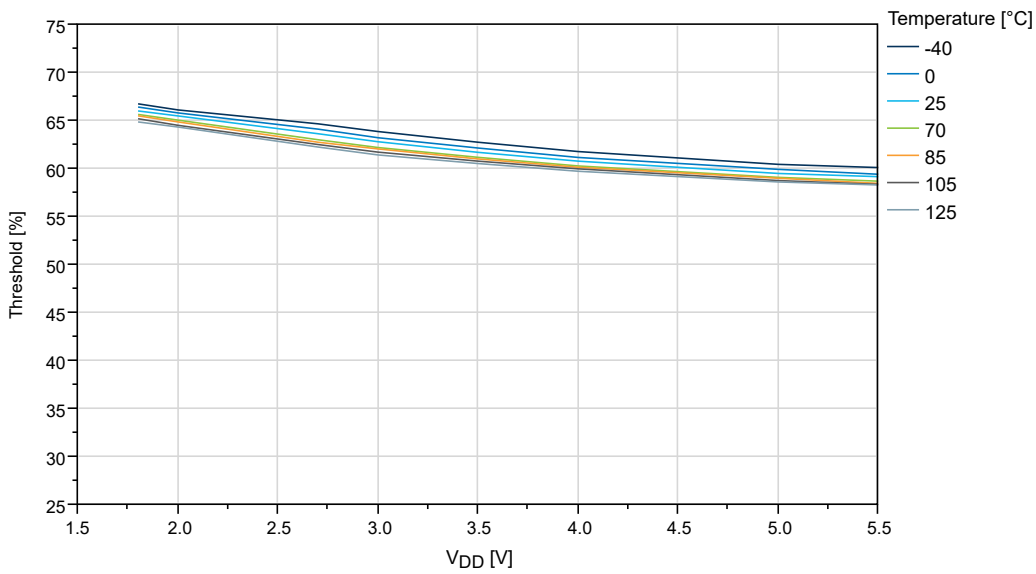
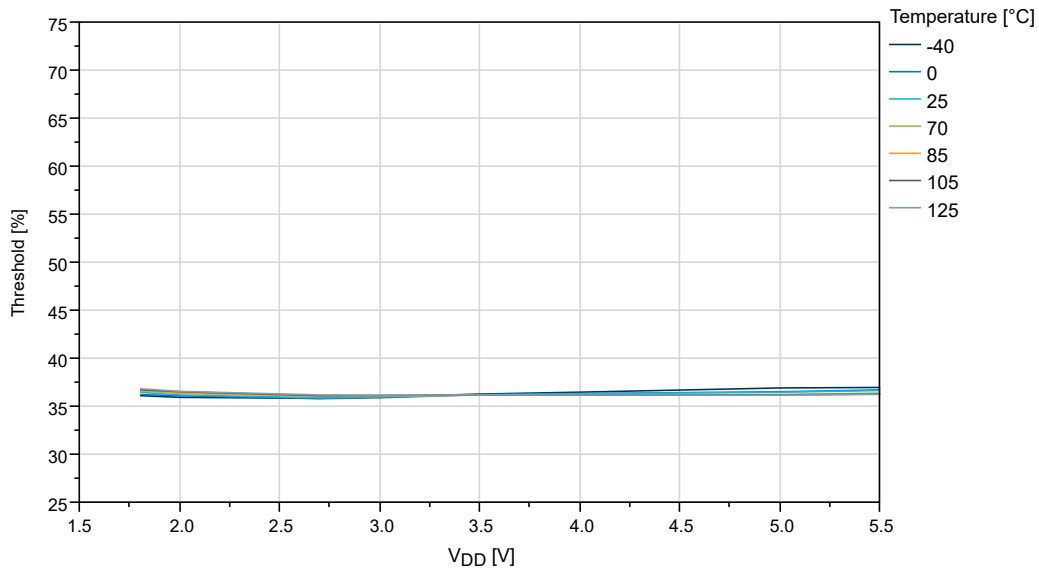

Figure 34-25. I/O Pin Input Threshold Voltage vs. V_{DD} (V_{IL})



34.2.2 GPIO Output Characteristics

Figure 34-26. I/O Pin Output Voltage vs. Sink Current ($V_{DD} = 1.8V$)

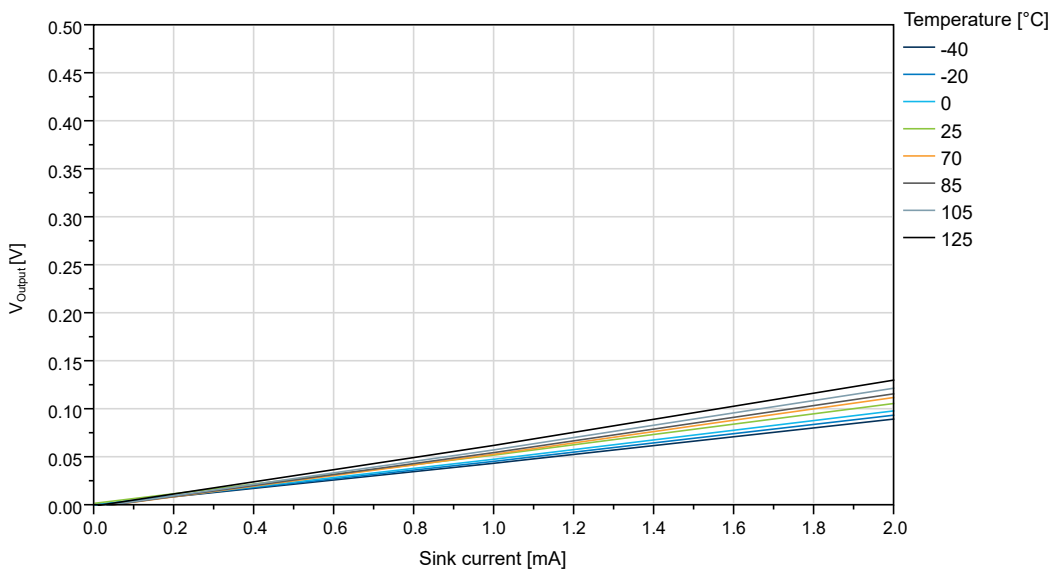

Figure 34-27. I/O Pin Output Voltage vs. Sink Current ($V_{DD} = 3.0V$)

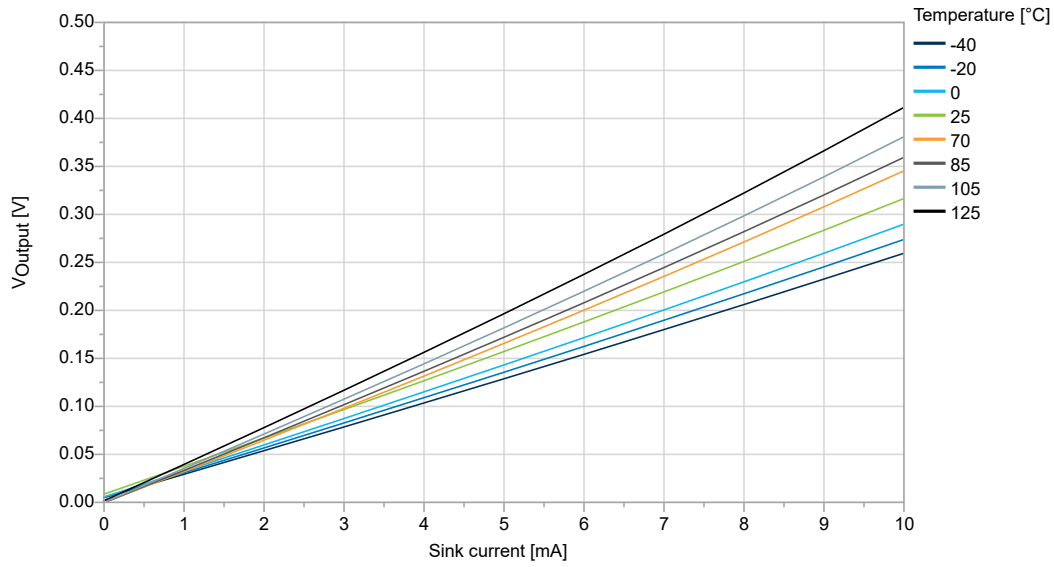

Figure 34-28. I/O Pin Output Voltage vs. Sink Current ($V_{DD} = 5.0V$)

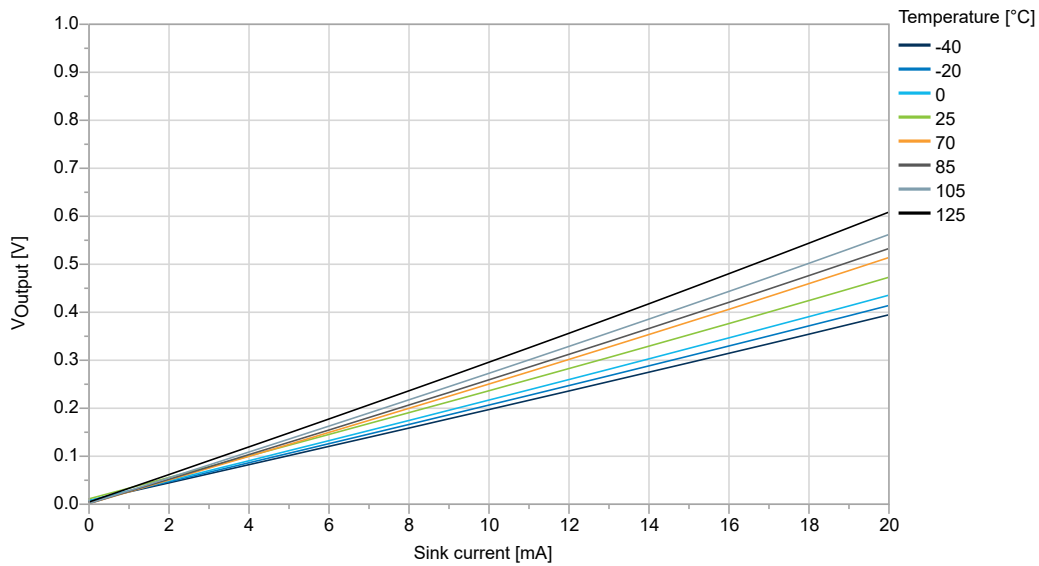

Figure 34-29. I/O Pin Output Voltage vs. Sink Current (T = 25°C)

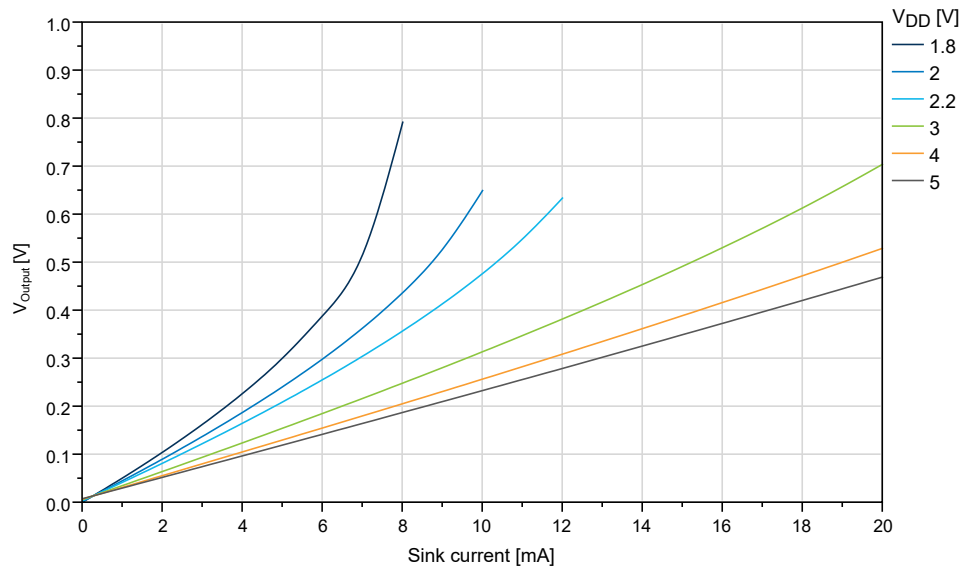

Figure 34-30. I/O Pin Output Voltage vs. Source Current ($V_{DD} = 1.8V$)

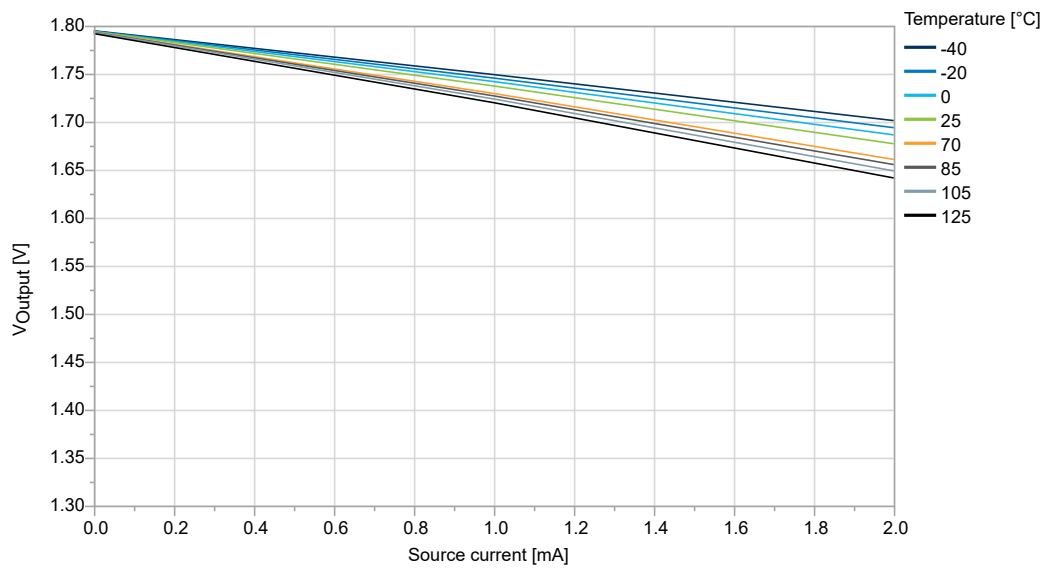

Figure 34-31. I/O Pin Output Voltage vs. Source Current ($V_{DD} = 3.0V$)

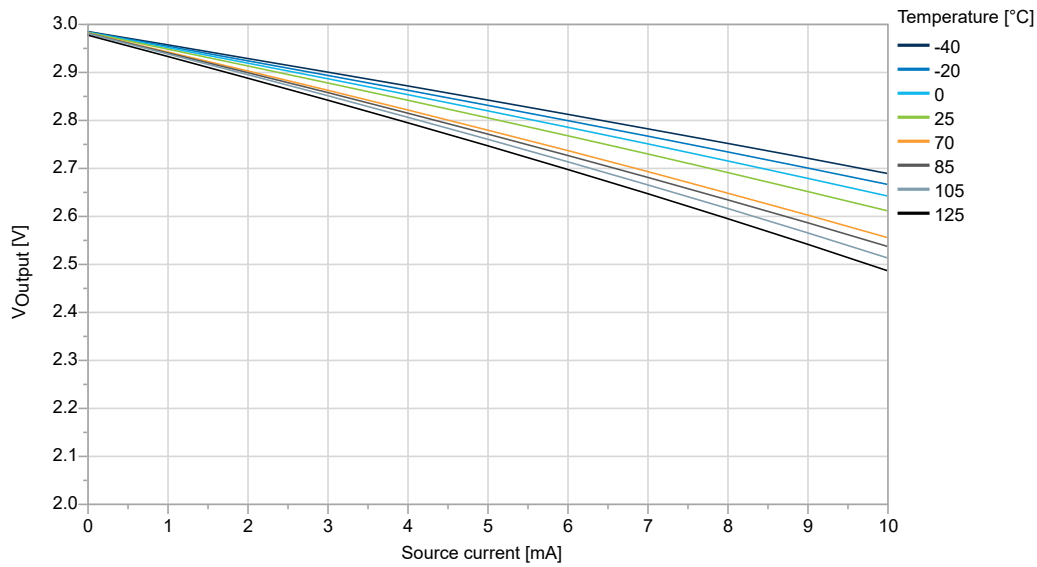

Figure 34-32. I/O Pin Output Voltage vs. Source Current ($V_{DD} = 5.0V$)

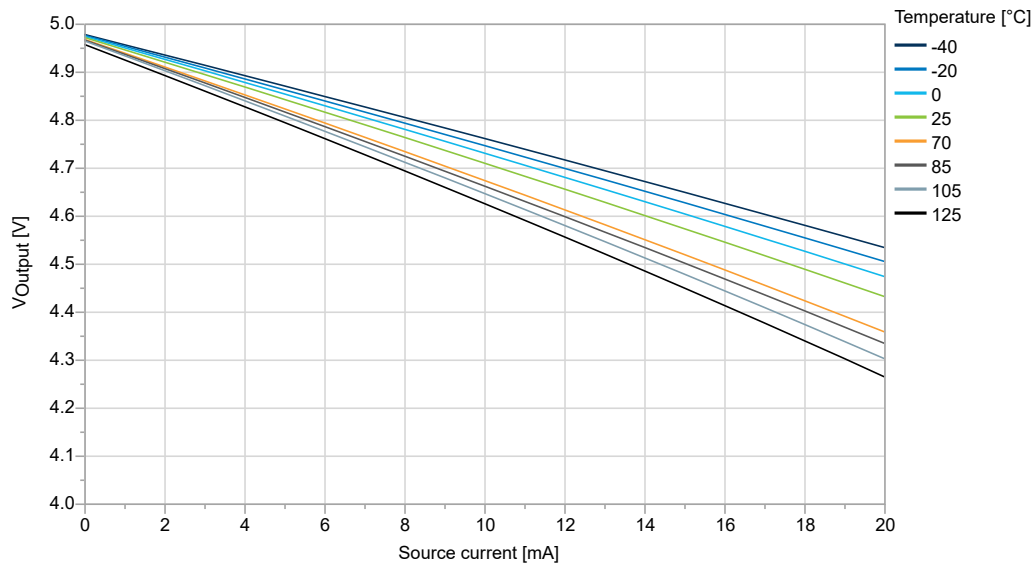
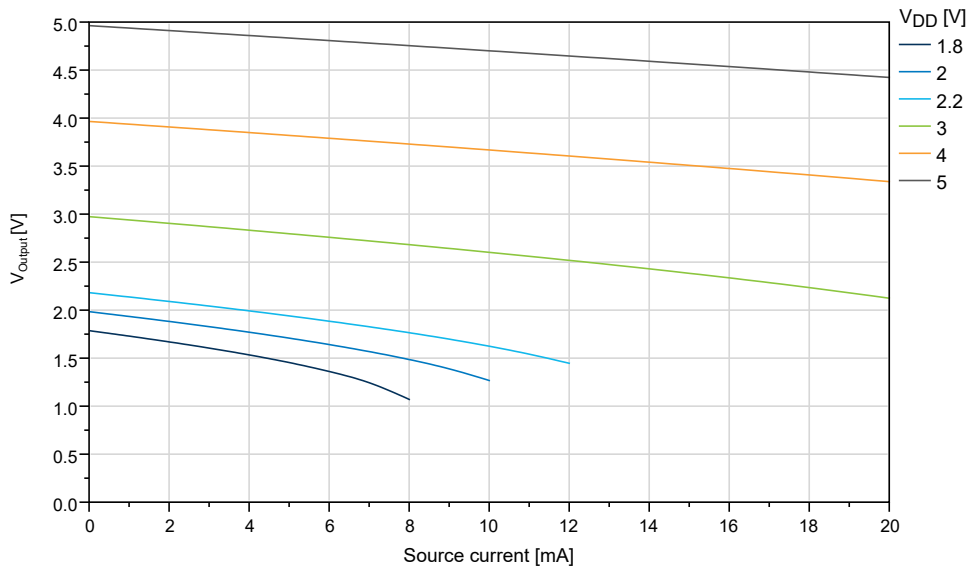

Figure 34-33. I/O Pin Output Voltage vs. Source Current (T = 25°C)



34.2.3 GPIO Pull-Up Characteristics

Figure 34-34. I/O Pin Pull-Up Resistor Current vs. Input Voltage ($V_{\text{DD}} = 1.8\text{V}$)

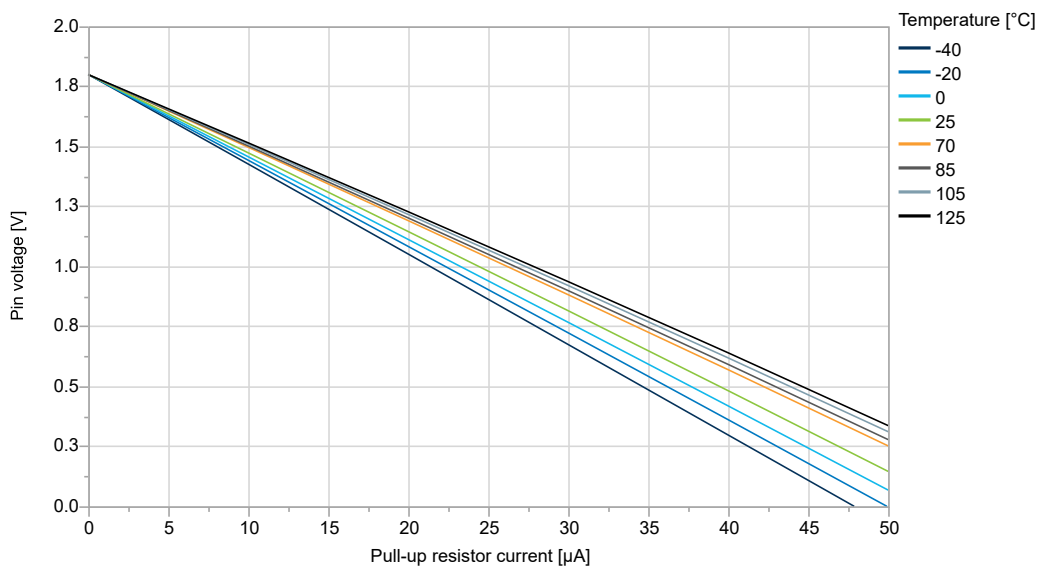

Figure 34-35. I/O Pin Pull-Up Resistor Current vs. Input Voltage ($V_{DD} = 3.0V$)

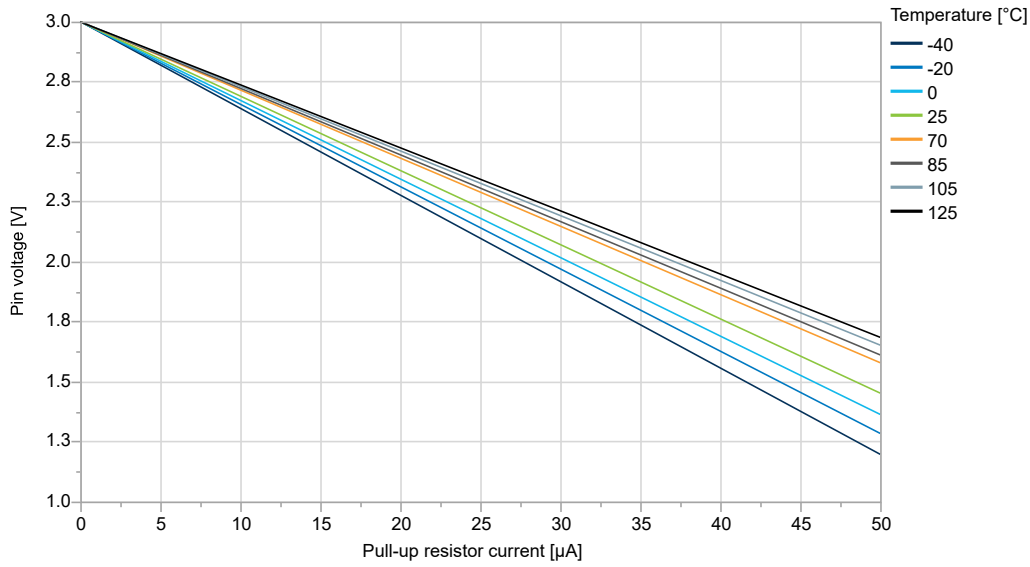
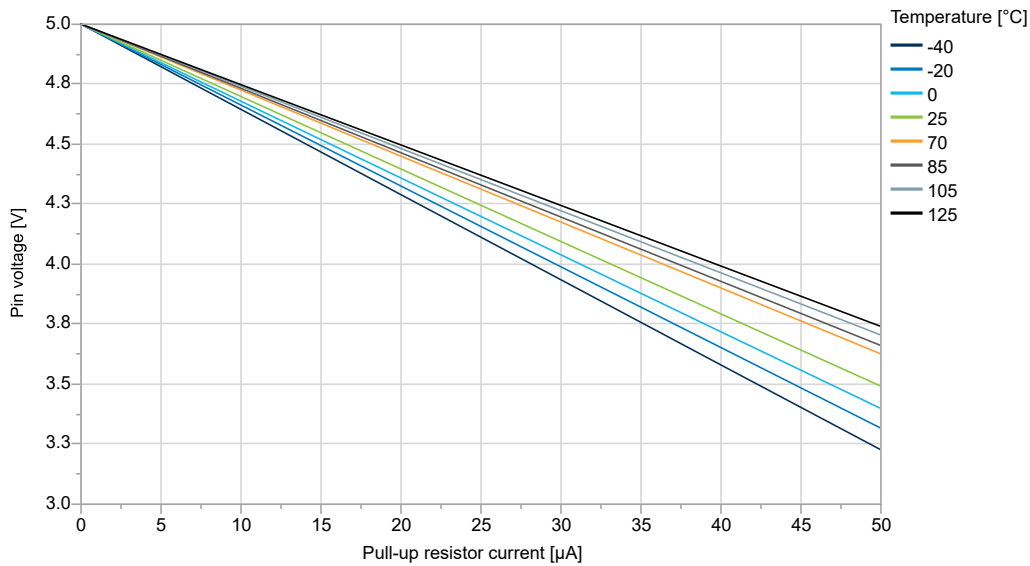

Figure 34-36. I/O Pin Pull-Up Resistor Current vs. Input Voltage ($V_{DD} = 5.0V$)



34.3 VREF Characteristics

Figure 34-37. VREF Accuracy vs. Temperature at $V_{DD} = 5.0V$, Internal References

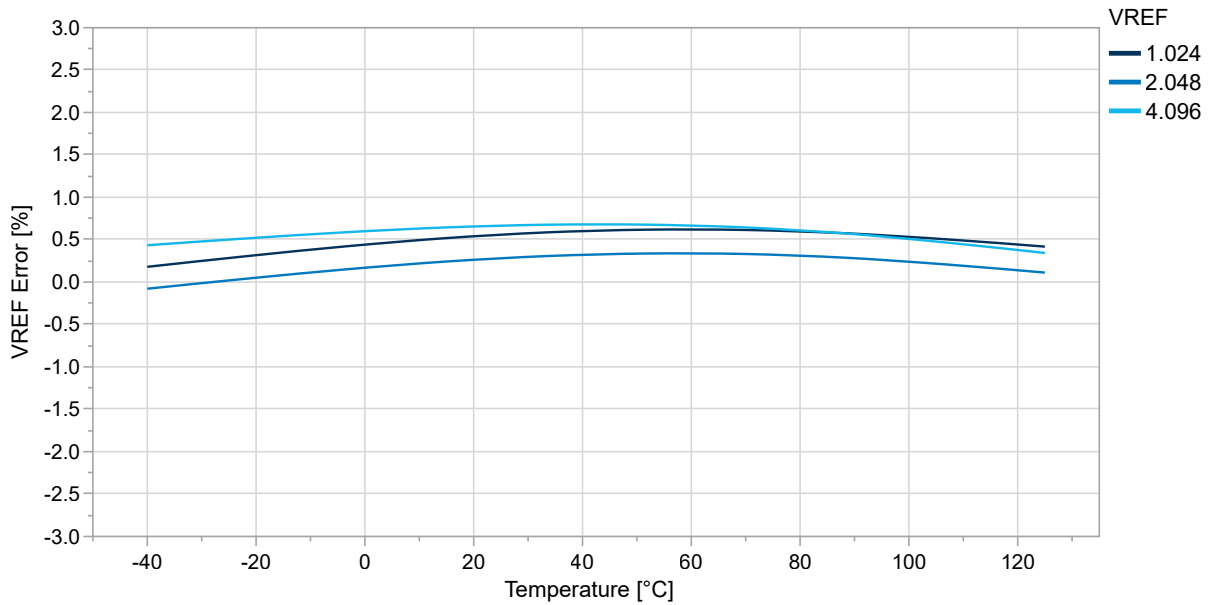
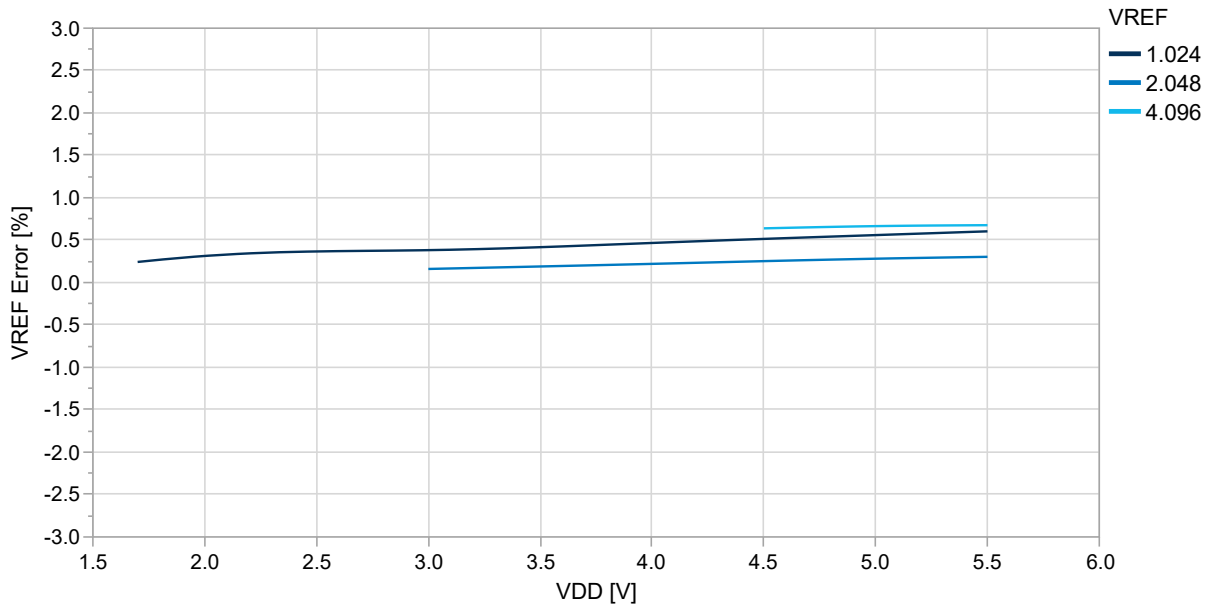

Figure 34-38. VREF Accuracy vs. V_{DD} at $T = 25^{\circ}C$, Internal References



34.4 BOD Characteristics

34.4.1 BOD Current vs. V_{DD}

Figure 34-39. BOD Current vs. V_{DD} (Continuous Mode enabled)

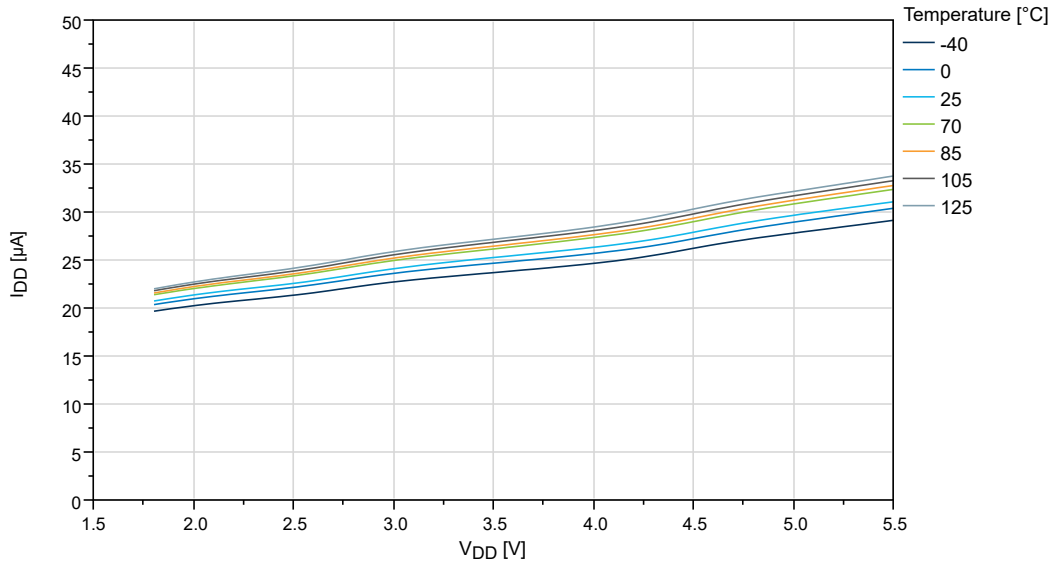

Figure 34-40. BOD Current vs. V_{DD} (Sampled BOD at 125 Hz)

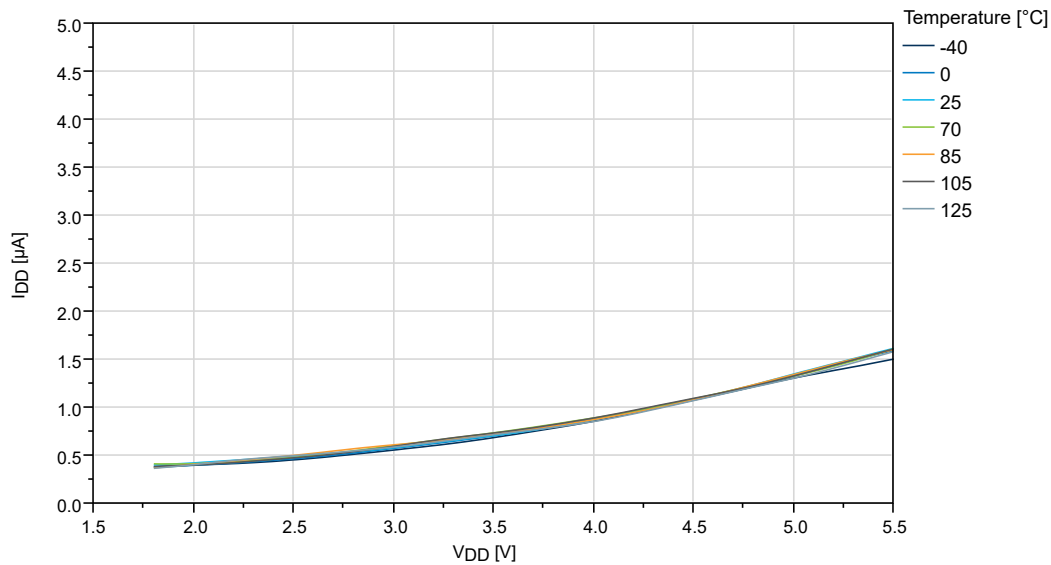
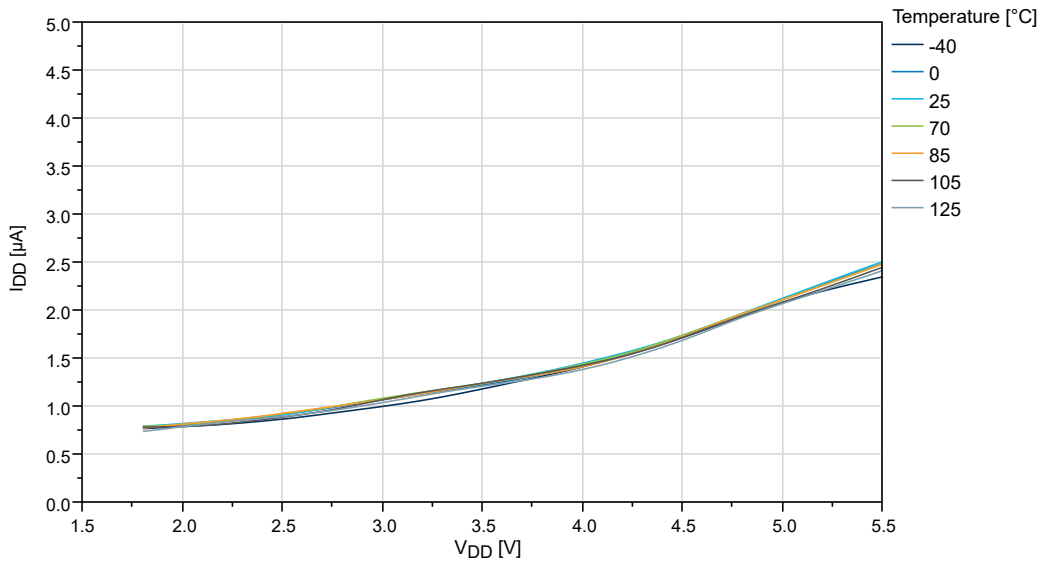

Figure 34-41. BOD Current vs. V_{DD} (Sampled BOD at 1 kHz)



34.4.2 BOD Threshold vs. Temperature

Figure 34-42. BOD Threshold vs. Temperature (BODLEVEL0)

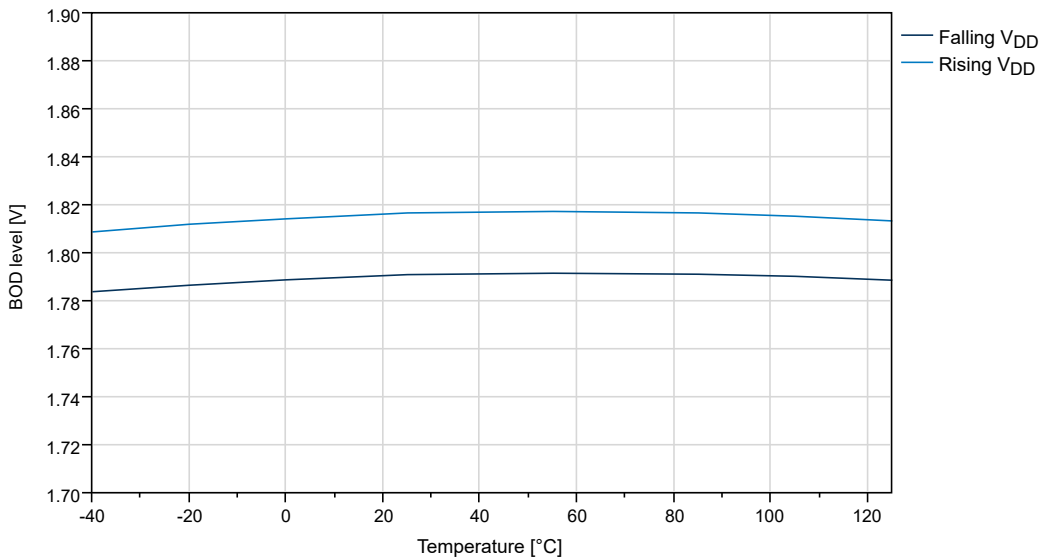

Figure 34-43. BOD Threshold vs. Temperature (BODLEVEL2)

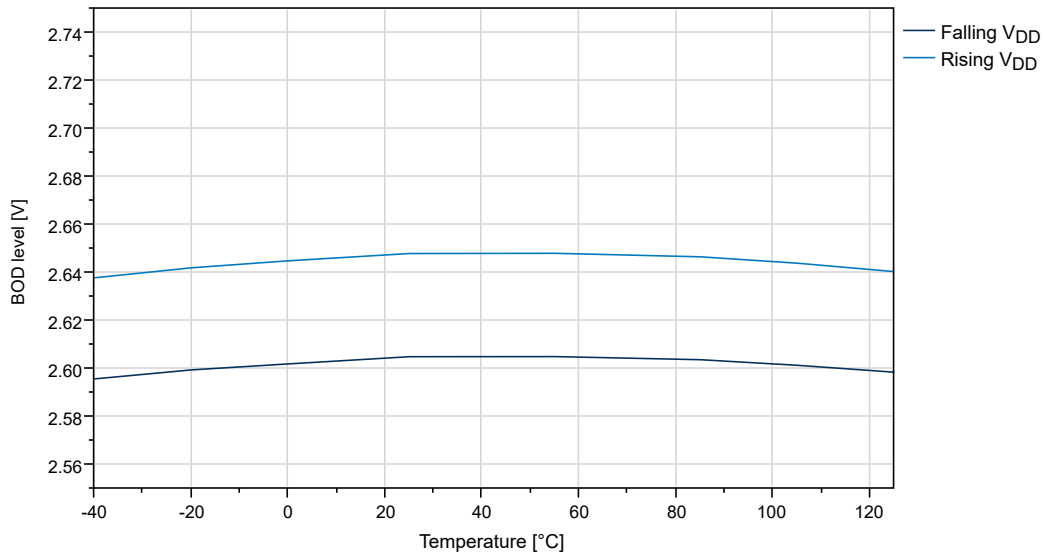
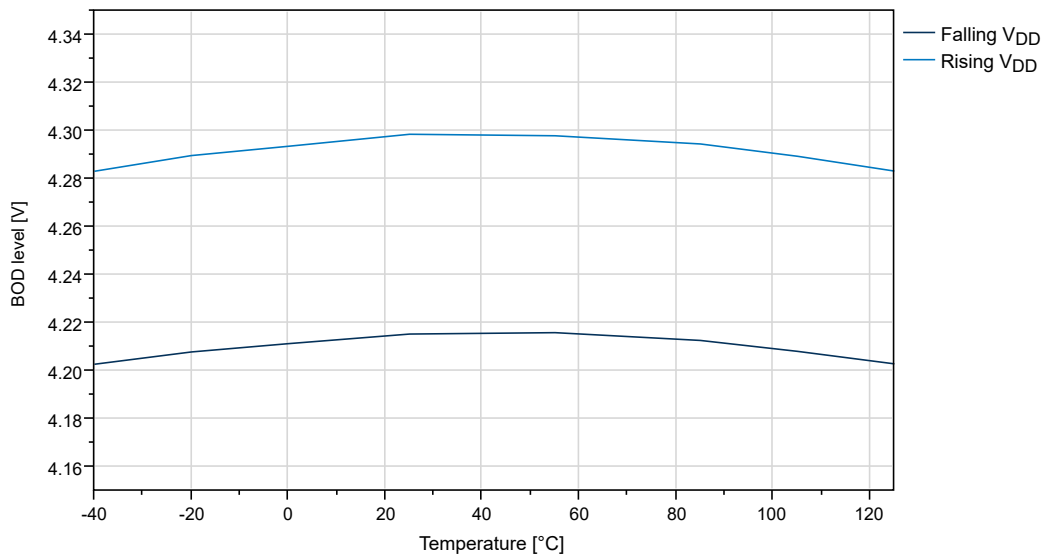

Figure 34-44. BOD Threshold vs. Temperature (BODLEVEL7)



34.5 ADC Characteristics

34.5.1 Absolute Accuracy

Figure 34-45. Absolute Accuracy vs. Temperature ($V_{DD} = 5.0V$, $f_{ADC} = 145$ kps), Differential, REFSEL = External Reference

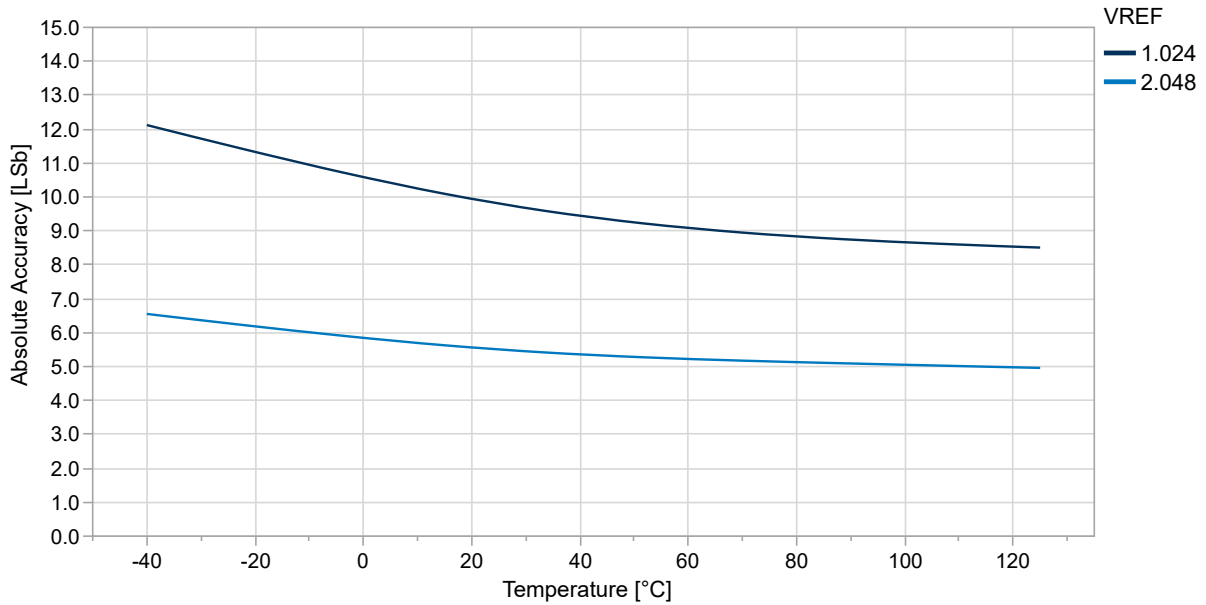

Figure 34-46. Absolute Accuracy vs. Temperature ($V_{DD} = 5.0V$, $f_{ADC} = 145$ kps), Differential, REFSEL = Internal Reference

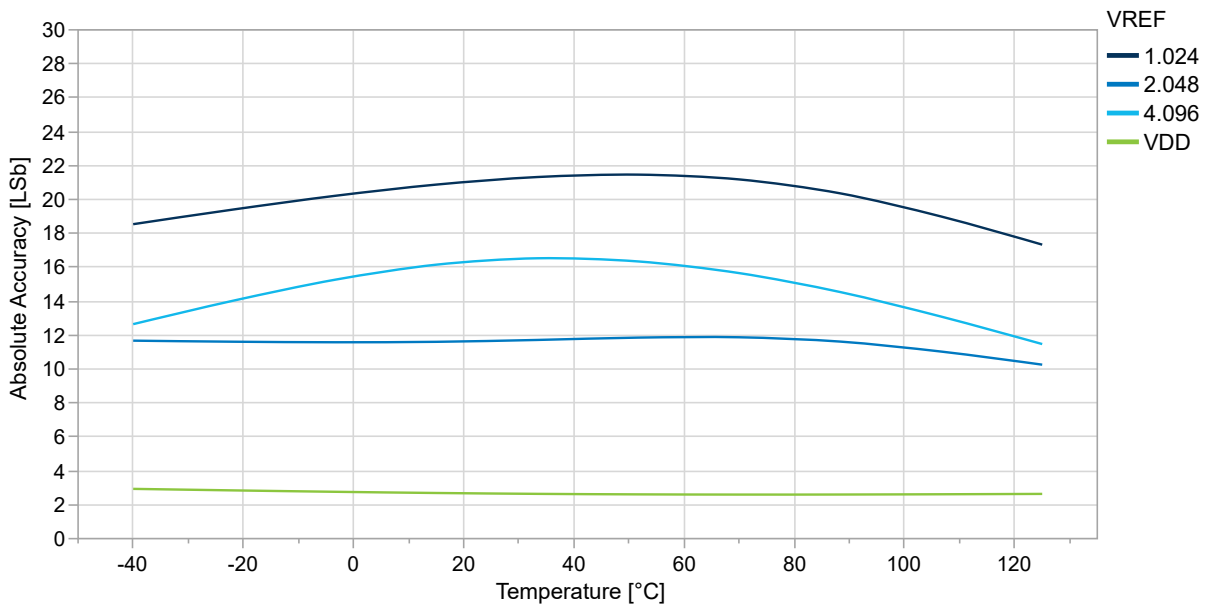

Figure 34-47. Absolute Accuracy vs. V_{DD} ($f_{ADC} = 145$ ksps) at $T = 25^{\circ}\text{C}$, Differential, REFSEL = External Reference

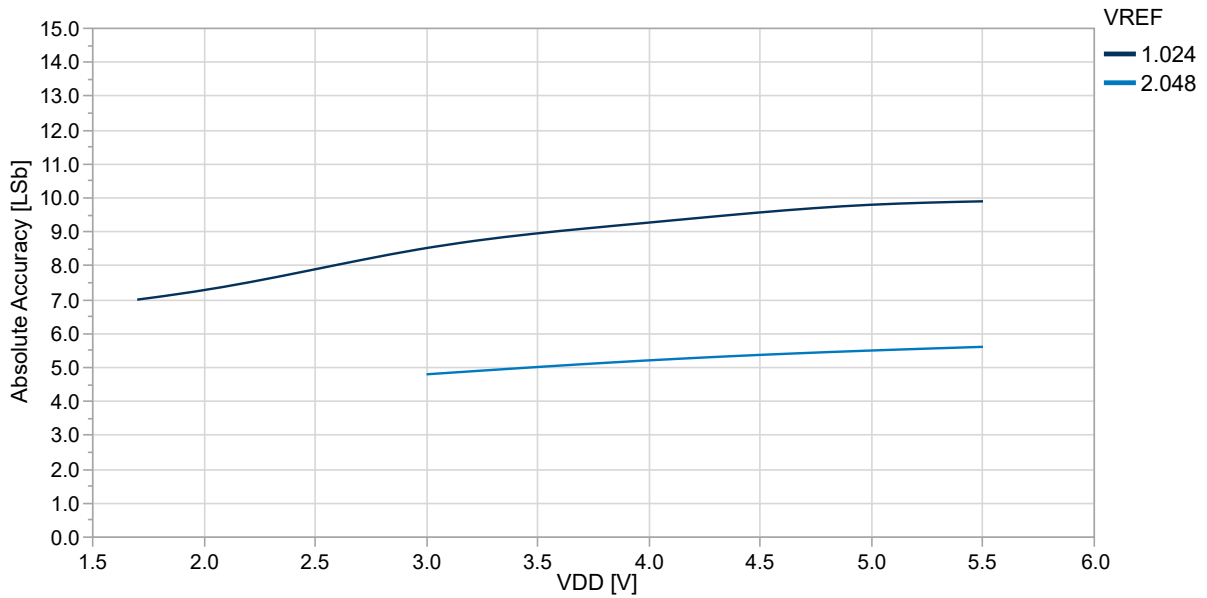
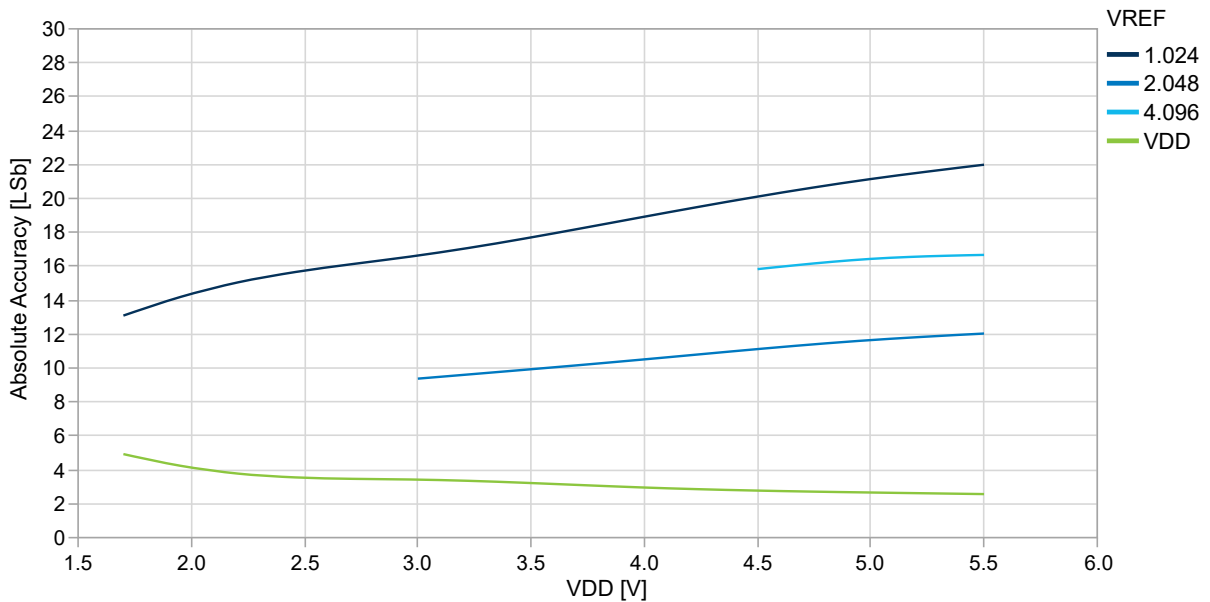

Figure 34-48. Absolute Accuracy vs. V_{DD} ($f_{ADC} = 145$ ksps) at $T = 25^{\circ}\text{C}$, Differential, REFSEL = Internal Reference



34.5.2 DNL

Figure 34-49. DNL vs. Code ($V_{DD} = 5.0V$, $T = 25^{\circ}C$, $f_{ADC} = 145$ kps), Differential, External 2.048V Reference

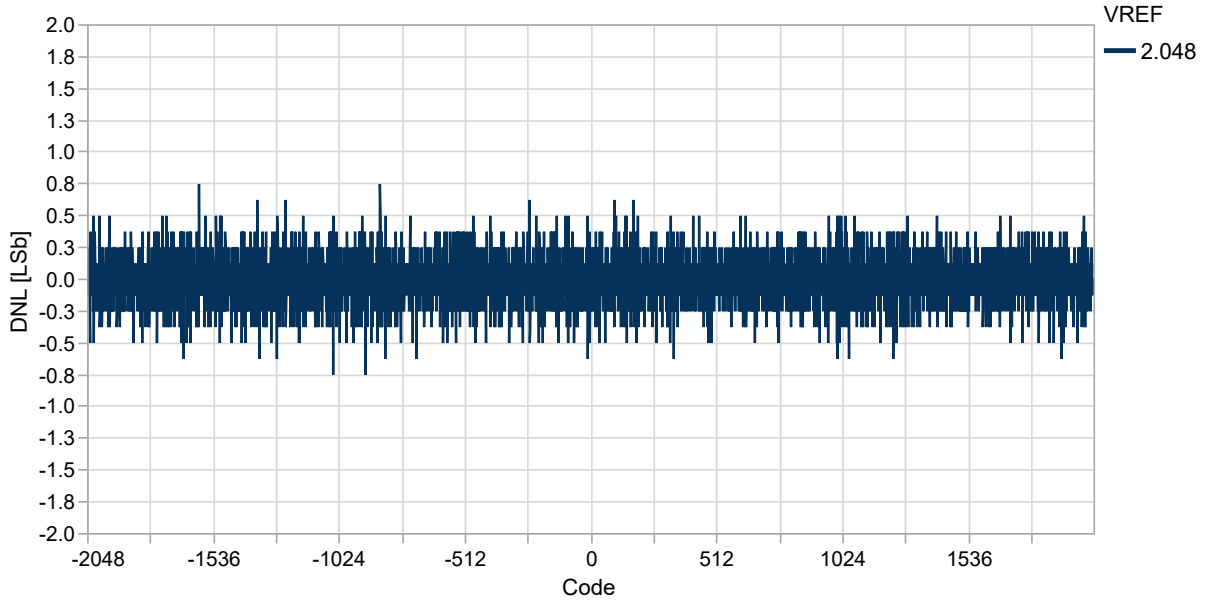

Figure 34-50. DNL vs. Temperature ($V_{DD} = 5.0V$, $f_{ADC} = 145$ kps), Differential, REFSEL = External Reference

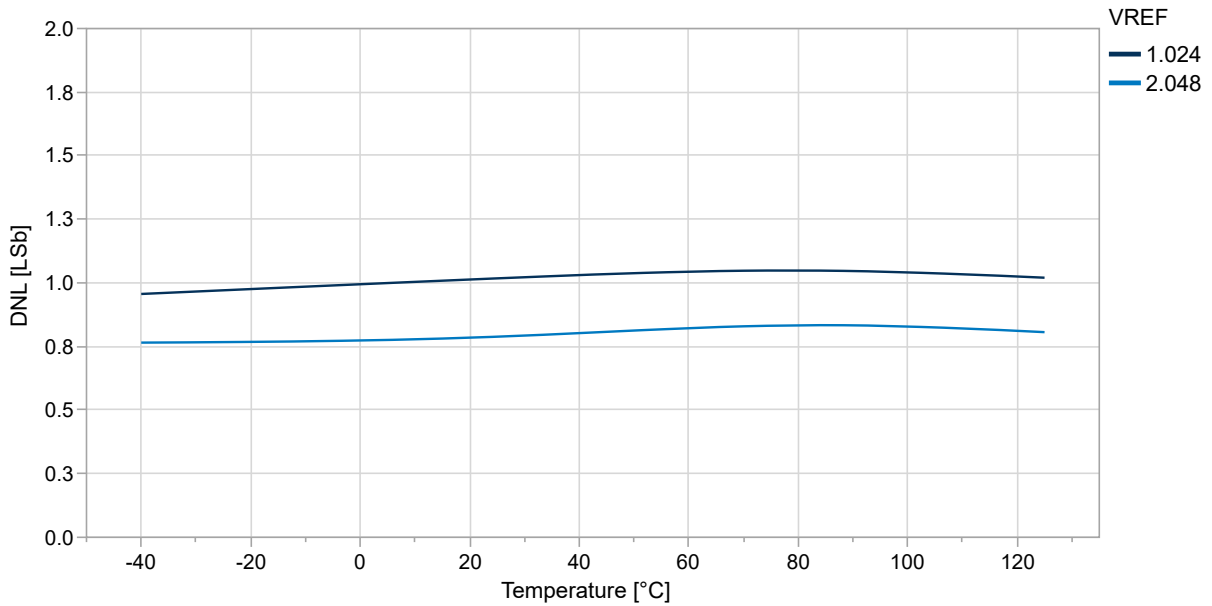

Figure 34-51. DNL vs. Temperature ($V_{DD} = 5.0V$, $f_{ADC} = 145$ kps), Differential, REFSEL = Internal Reference

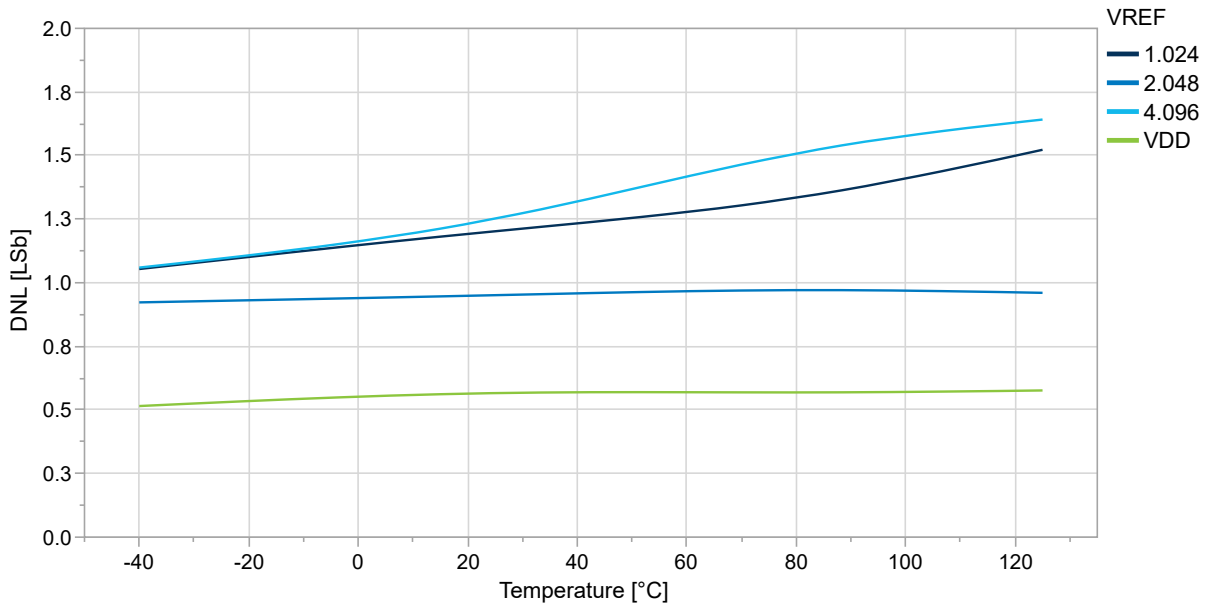

Figure 34-52. DNL vs. V_{DD} ($f_{ADC} = 145$ kps) at $T = 25^{\circ}C$, Differential, REFSEL = External Reference

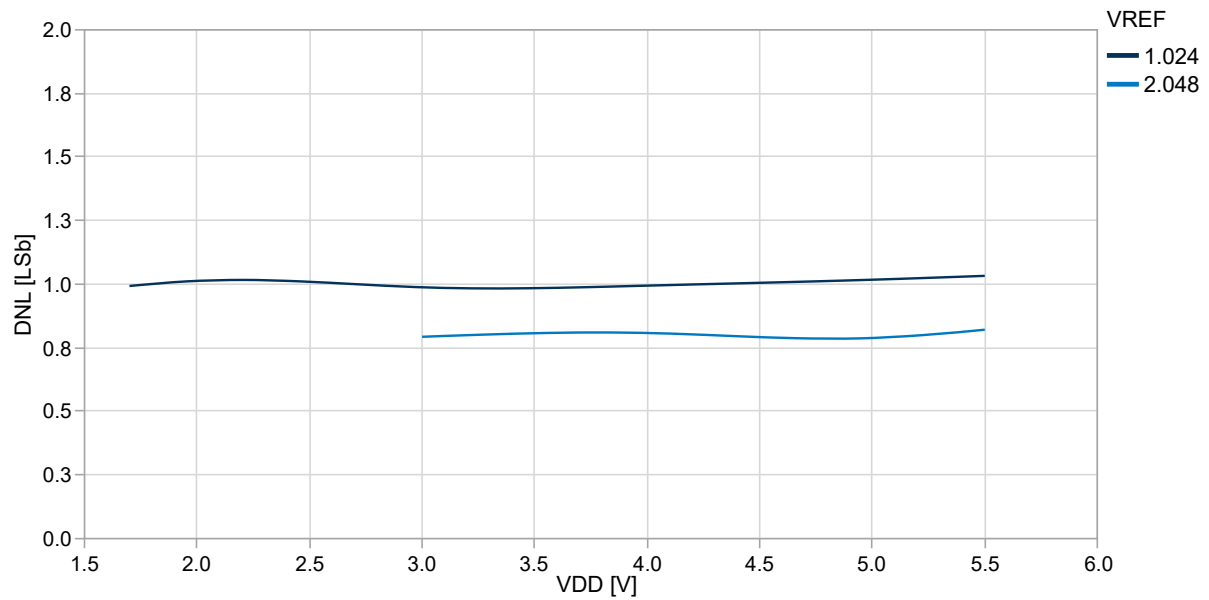
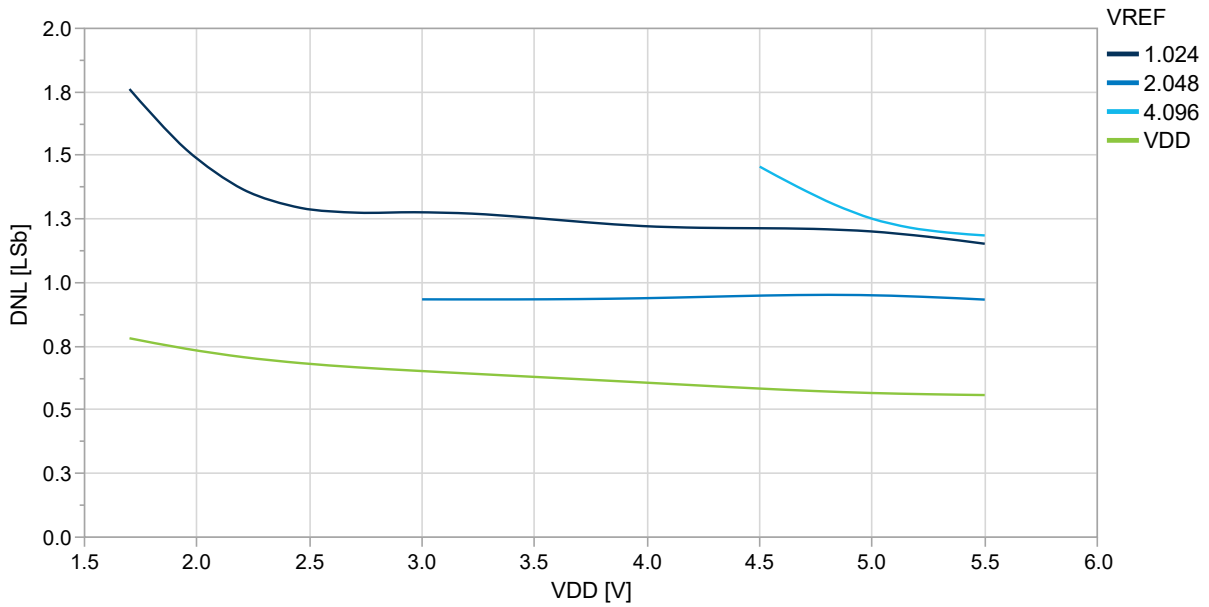

Figure 34-53. DNL vs. V_{DD} ($f_{ADC} = 145$ kps) at $T = 25^{\circ}\text{C}$, Differential, REFSEL = Internal Reference



34.5.3 Gain Error

Figure 34-54. Gain Error vs. Temperature ($V_{DD} = 5.0\text{V}$, $f_{ADC} = 145$ kps), Differential, REFSEL = External Reference

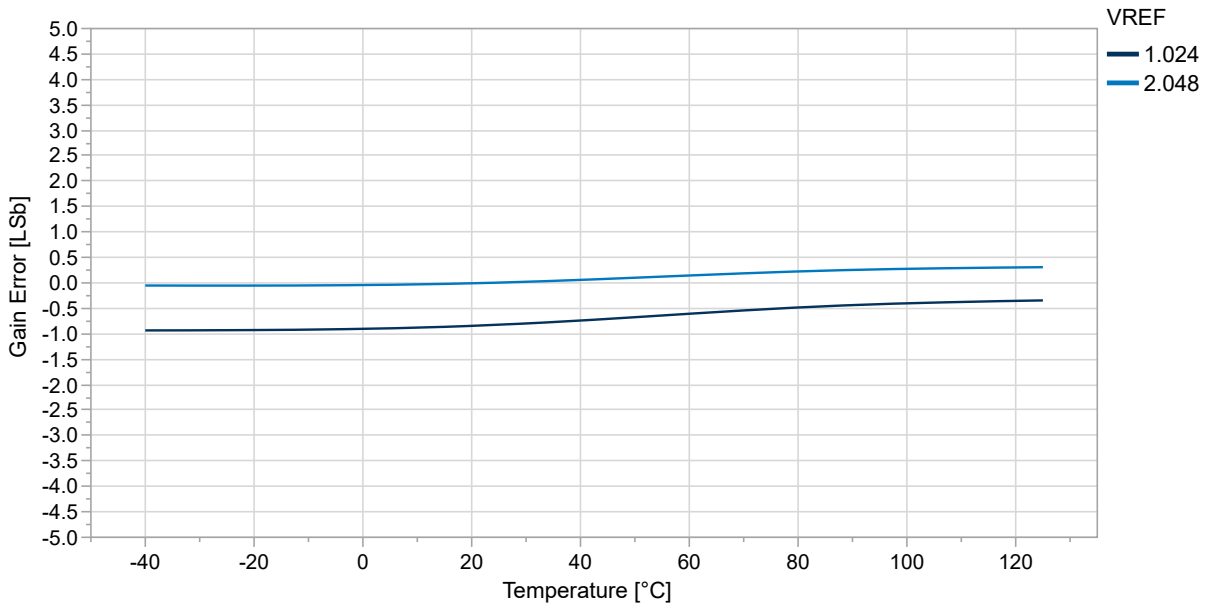

Figure 34-55. Gain Error vs. Temperature ($V_{DD} = 5.0V$, $f_{ADC} = 145$ ksp/s), Differential, REFSEL = Internal Reference

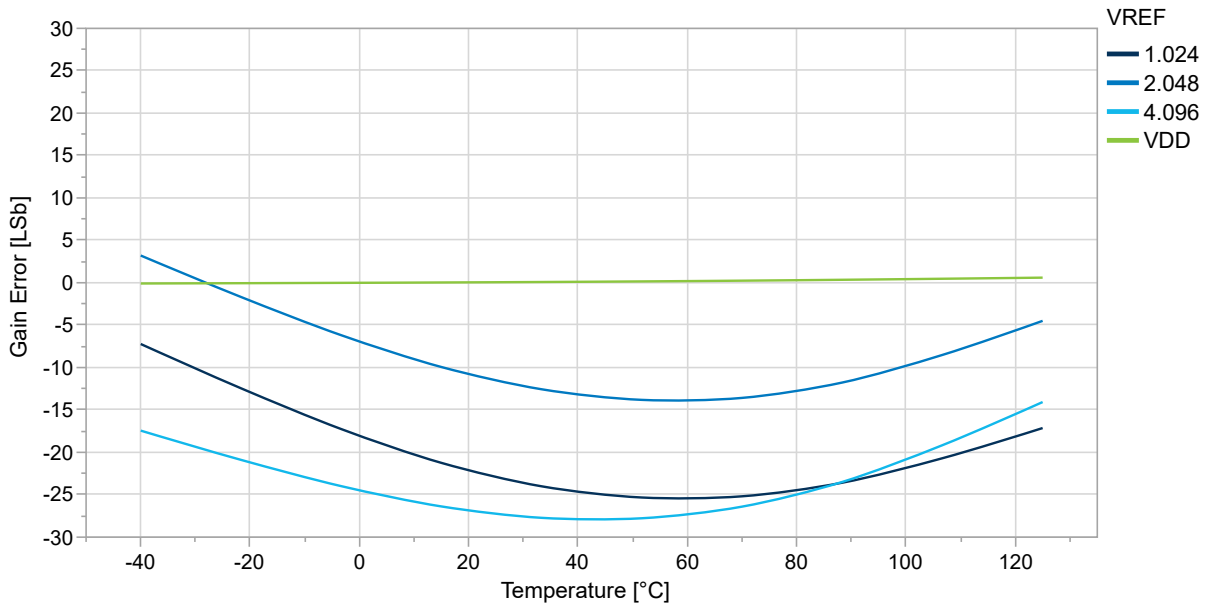

Figure 34-56. Gain Error vs. V_{DD} ($f_{ADC} = 145$ ksp/s) at $T = 25^{\circ}C$, Differential, REFSEL = External Reference

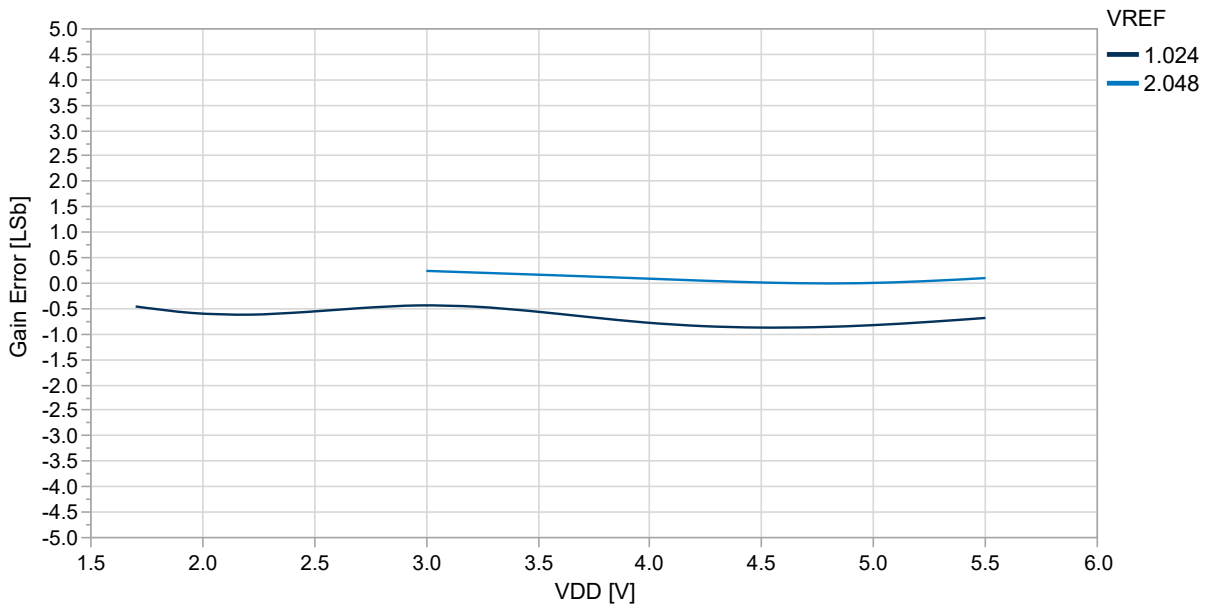
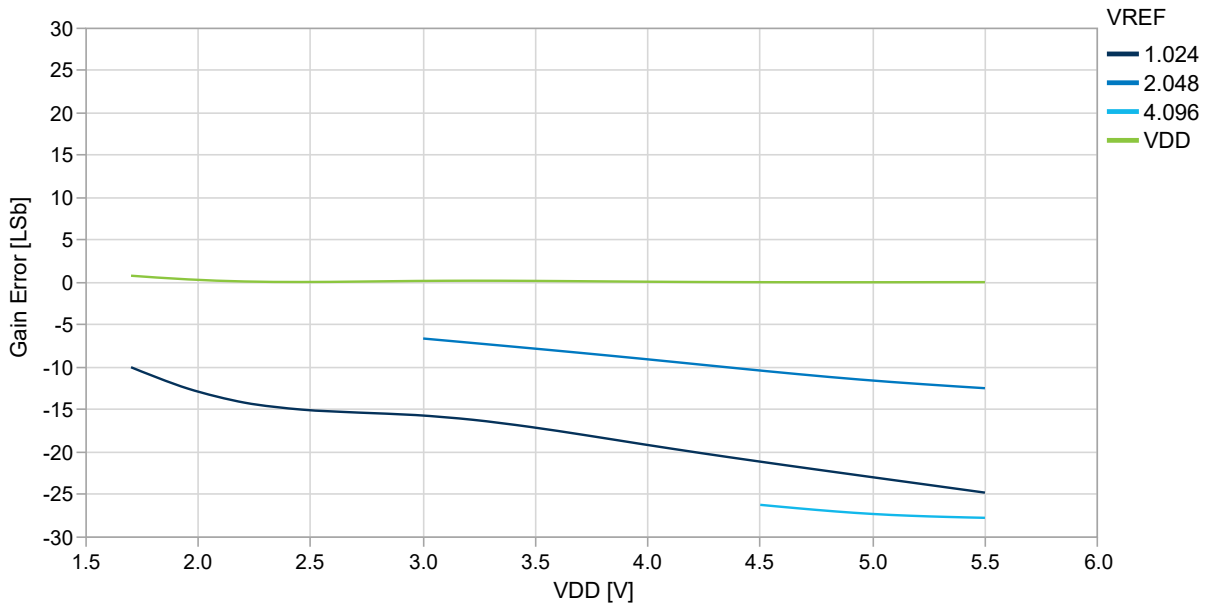
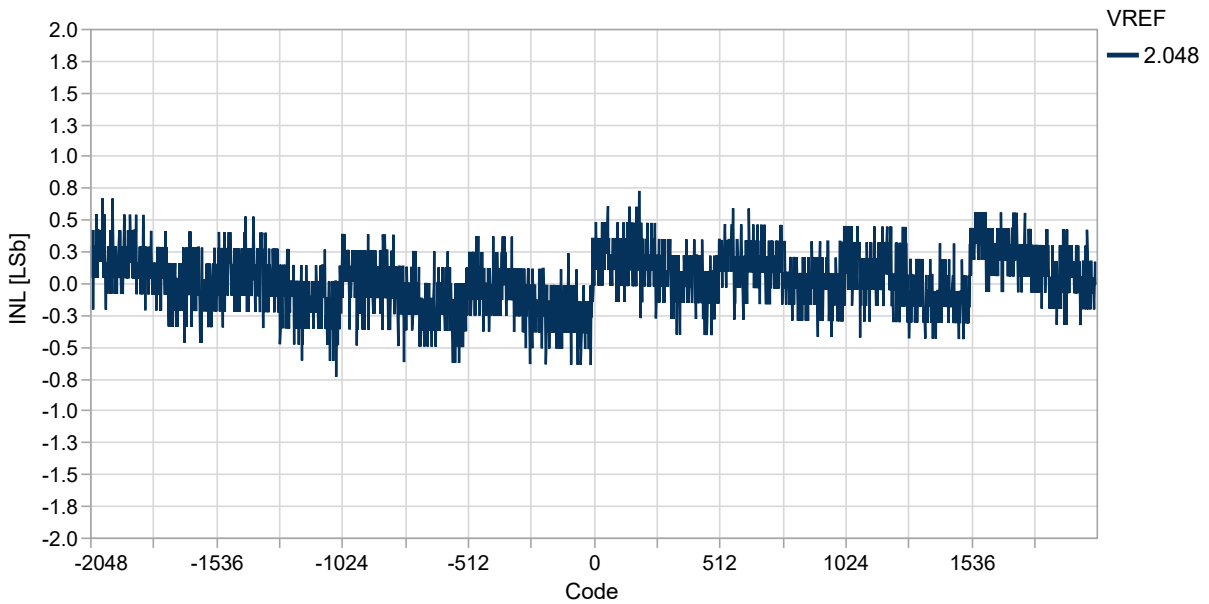

Figure 34-57. Gain Error vs. V_{DD} ($f_{ADC} = 145$ kps) at $T = 25^{\circ}\text{C}$, Differential, REFSEL = Internal Reference



34.5.4 INL

Figure 34-58. INL vs. Code ($V_{DD} = 5.0\text{V}$, $T = 25^{\circ}\text{C}$, $f_{ADC} = 145$ kps), Differential, External 2.048V Reference



ATtiny3224/3226/3227

Typical Characteristics

Figure 34-59. INL vs. Temperature ($V_{DD} = 5.0V$, $f_{ADC} = 145$ kps), Differential, REFSEL = External Reference

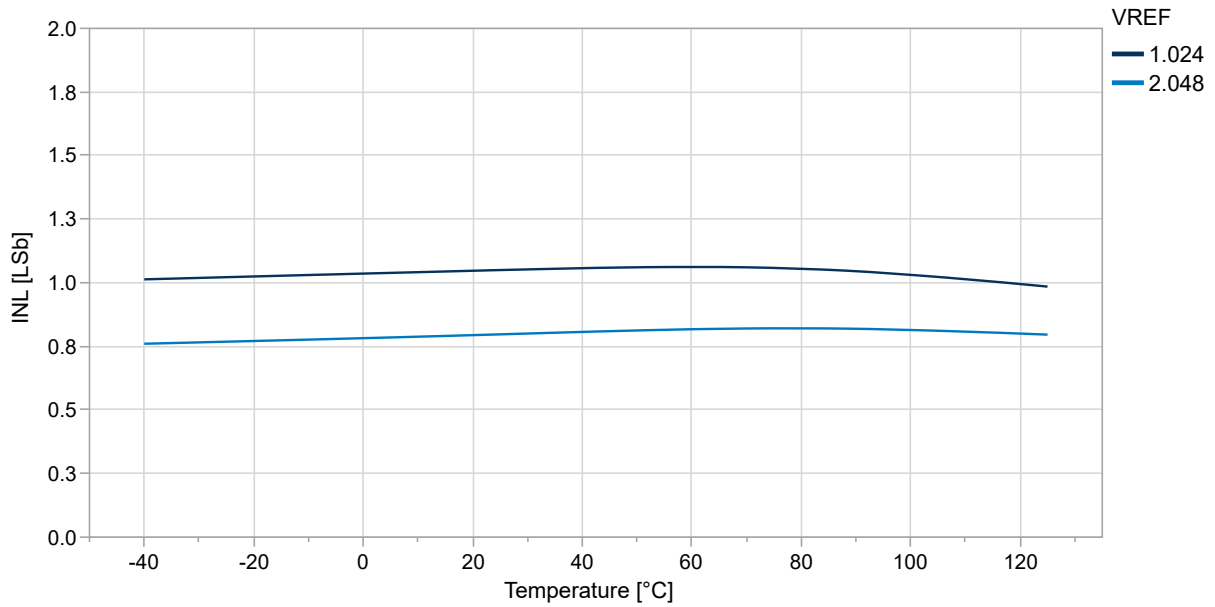

Figure 34-60. INL vs. Temperature ($V_{DD} = 5.0V$, $f_{ADC} = 145$ kps), Differential, REFSEL = Internal Reference

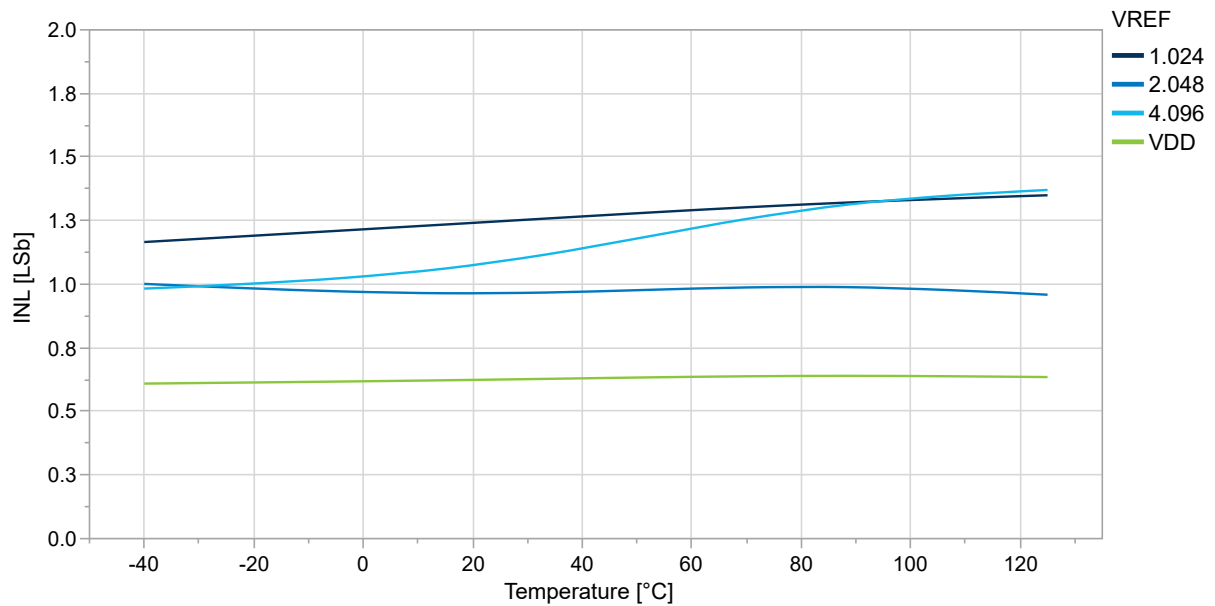

Figure 34-61. INL vs. V_{DD} ($f_{ADC} = 145$ kps) at $T = 25^{\circ}\text{C}$, Differential, REFSEL = External Reference

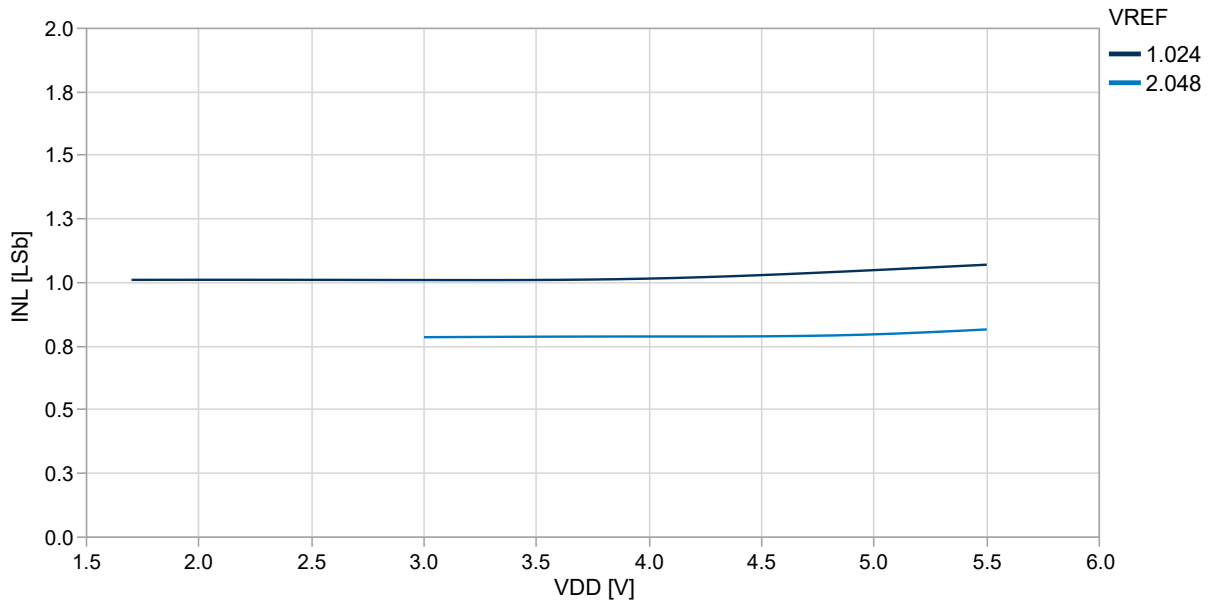
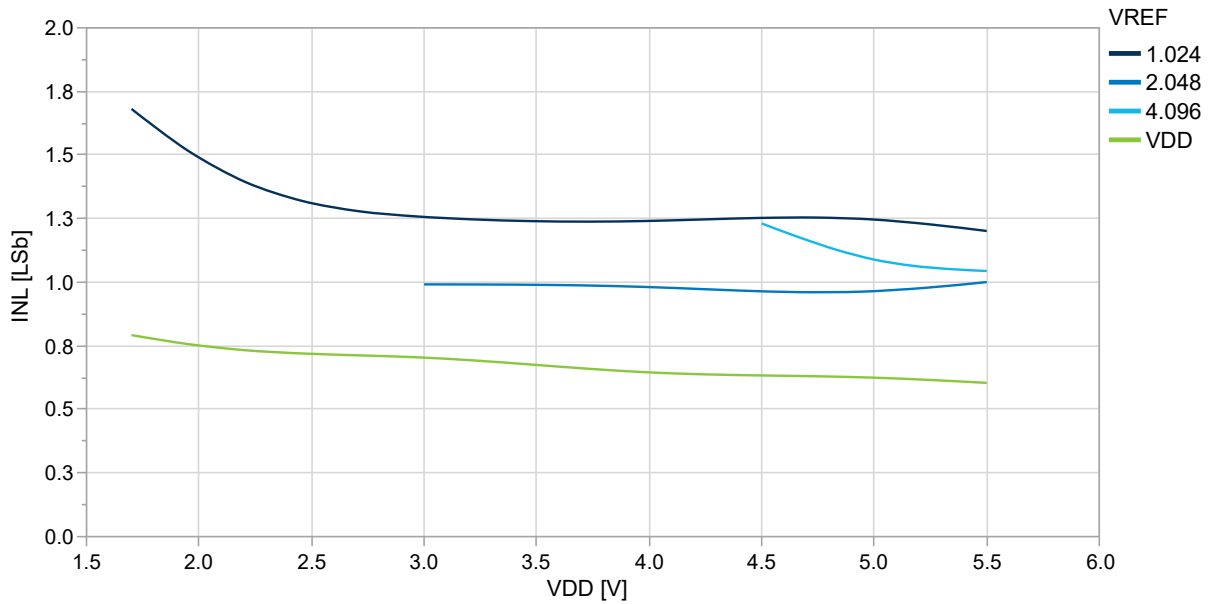

Figure 34-62. INL vs. V_{DD} ($f_{ADC} = 145$ kps) at $T = 25^{\circ}\text{C}$, Differential, REFSEL = Internal Reference



34.5.5 Offset Error

Figure 34-63. Offset Error vs. Temperature ($V_{DD} = 5.0V$, $f_{ADC} = 145$ kps), Differential, REFSEL = External Reference

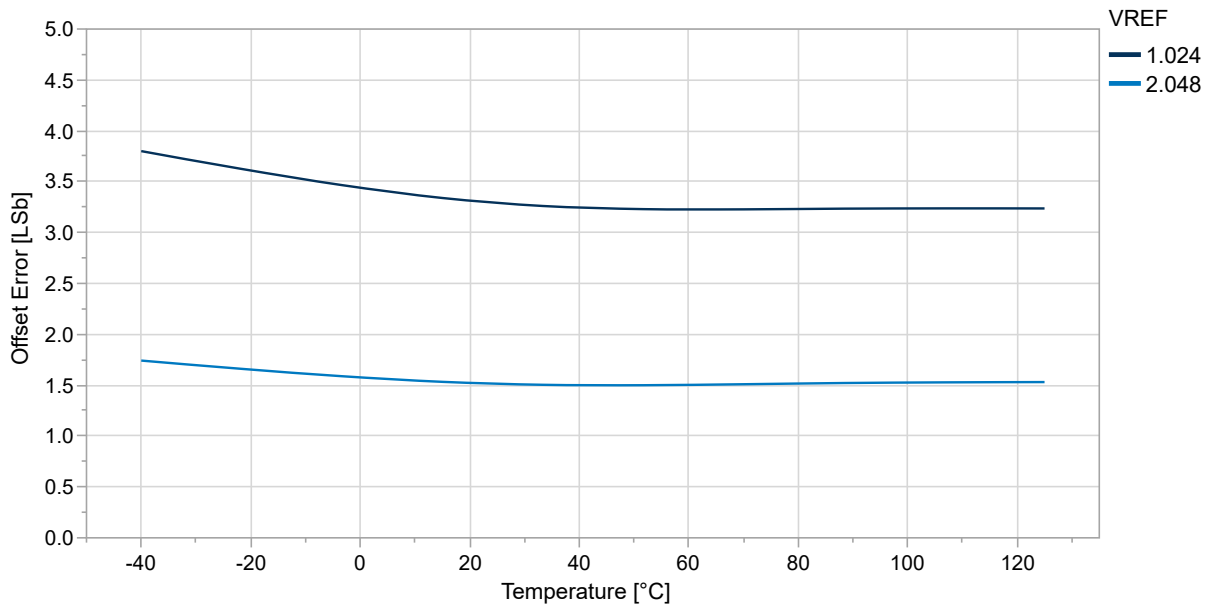
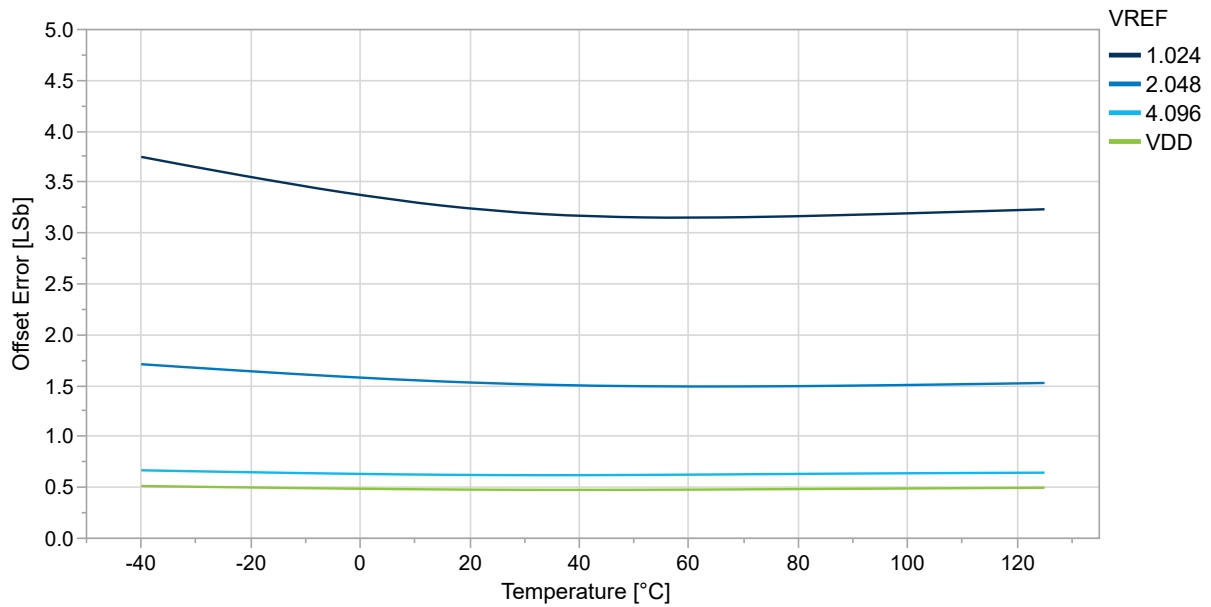

Figure 34-64. Offset Error vs. Temperature ($V_{DD} = 5.0V$, $f_{ADC} = 145$ kps), Differential, REFSEL = Internal Reference



ATtiny3224/3226/3227

Typical Characteristics

Figure 34-65. Offset Error vs. V_{DD} ($f_{ADC} = 145$ kps) at $T = 25^{\circ}\text{C}$, Differential, REFSEL = External Reference

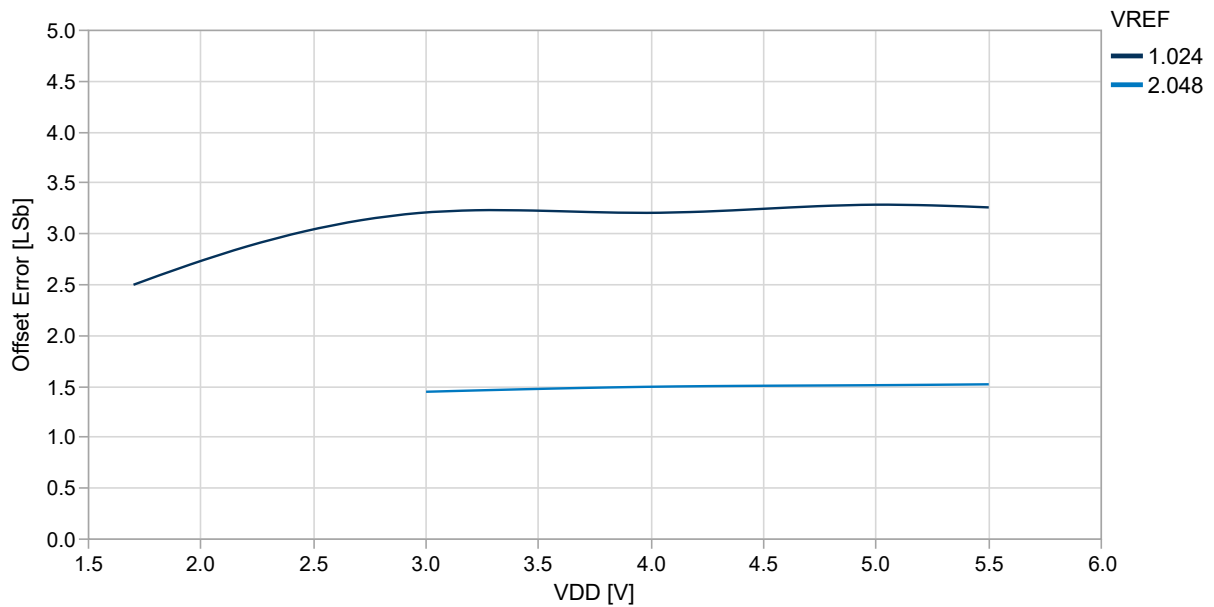
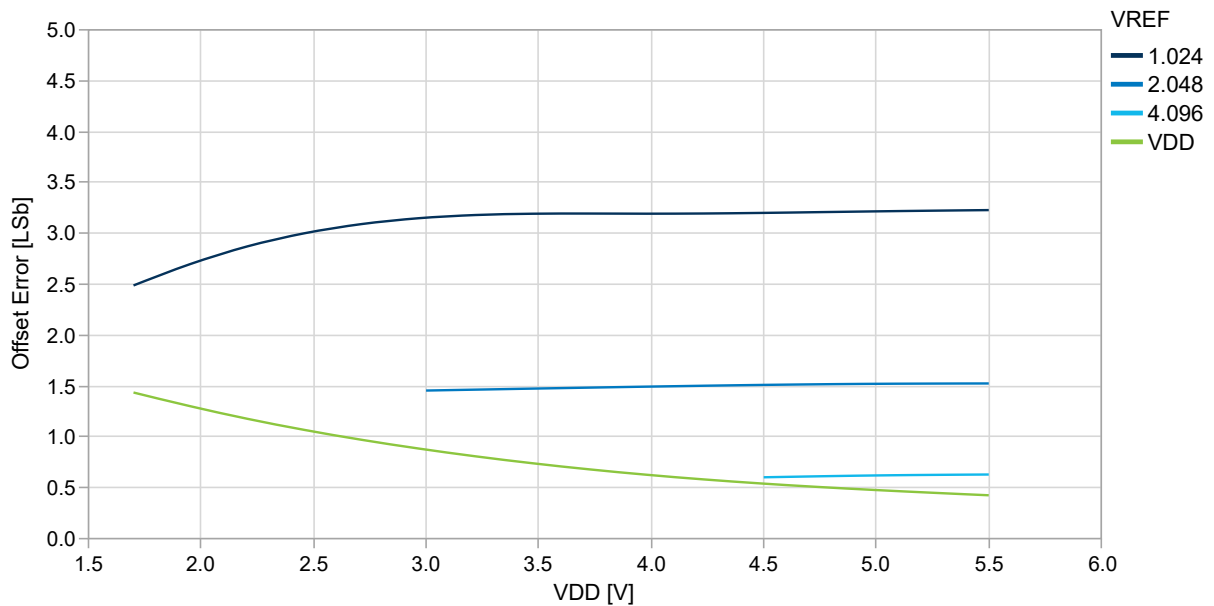

Figure 34-66. Offset Error vs. V_{DD} ($f_{ADC} = 145$ kps) at $T = 25^{\circ}\text{C}$, Differential, REFSEL = Internal Reference



34.5.6 PGA Characteristics

Figure 34-67. Gain Error vs. Temperature at $V_{DD} = 3V$, $V_{CM} = \min$

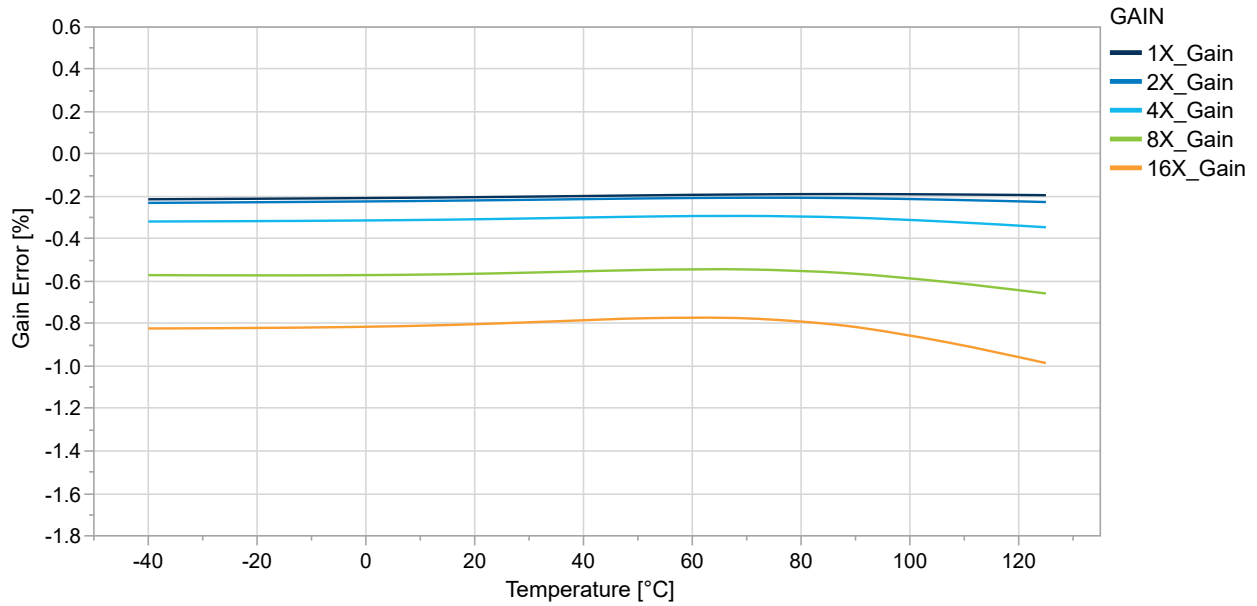

Figure 34-68. Gain Error vs. V_{DD} at $T = 25^\circ\text{C}$, $V_{CM} = \min$

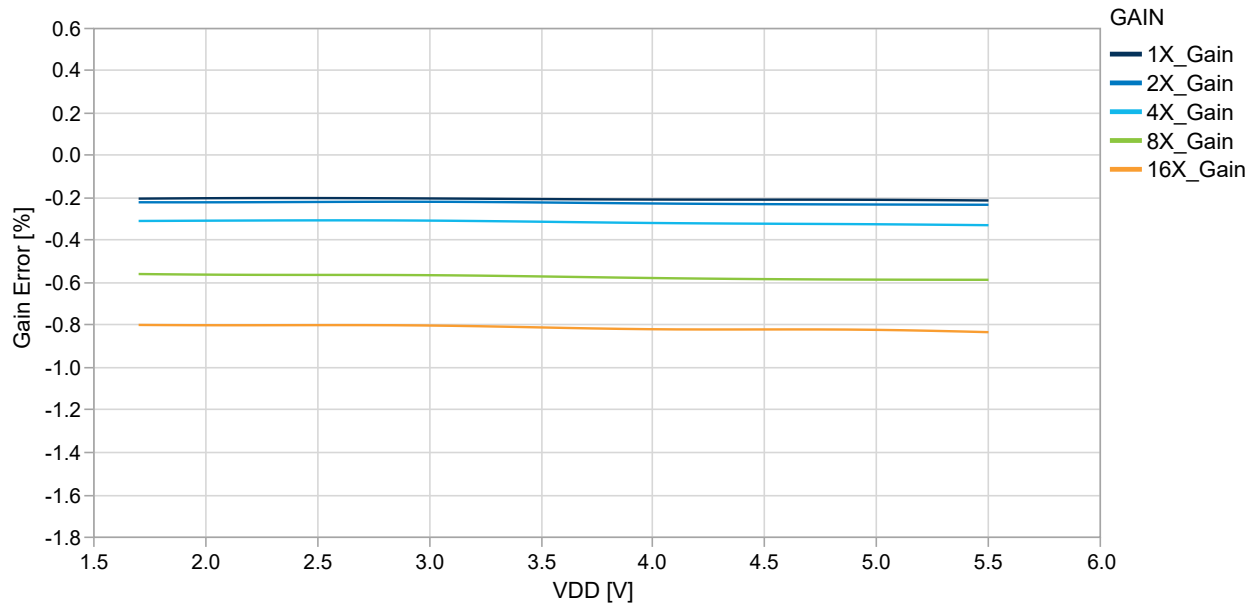

Figure 34-69. Offset Error vs. Temperature at $V_{DD} = 3V$, $V_{CM} = \min$

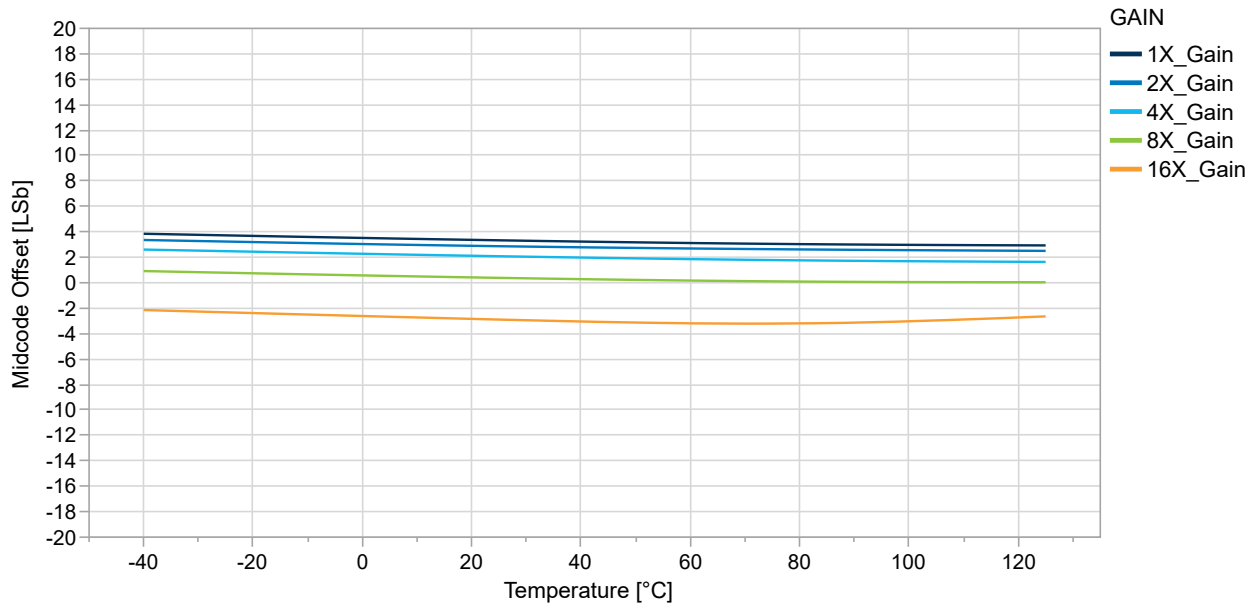
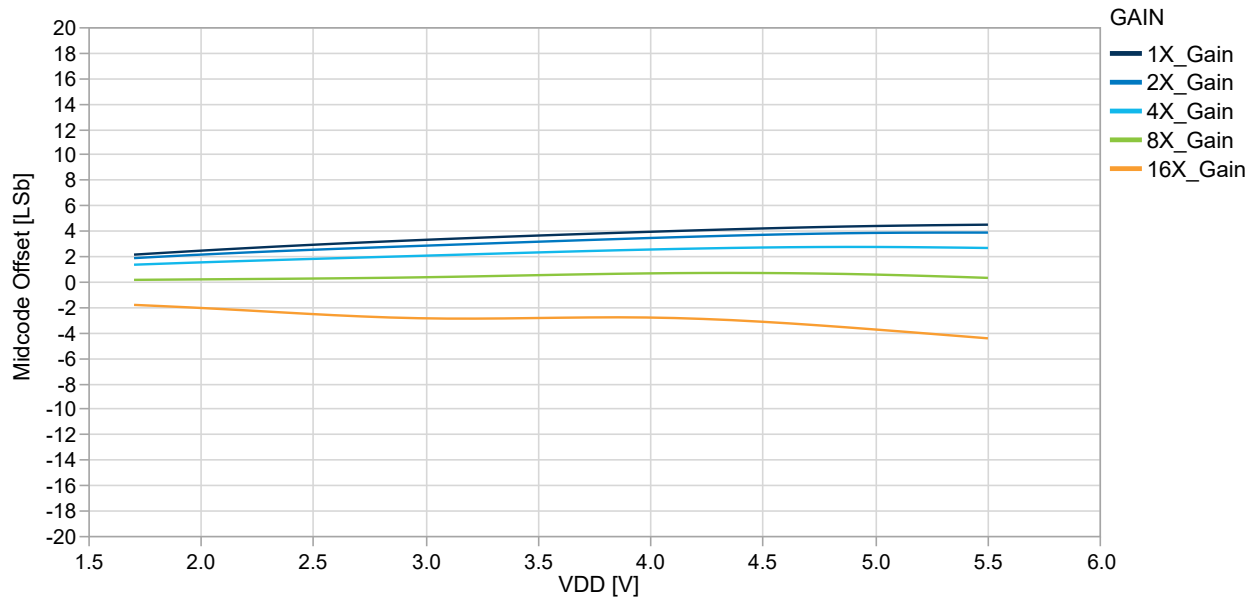
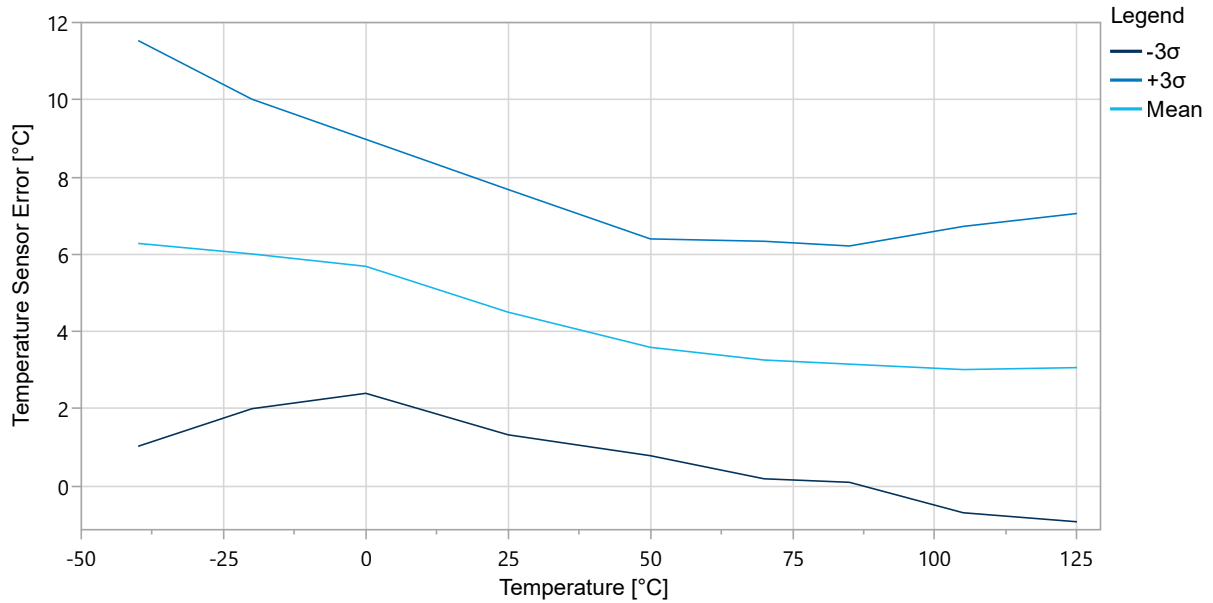

Figure 34-70. Offset Error vs. V_{DD} at $T = 25^\circ\text{C}$, $V_{CM} = \min$



34.6 TEMPESENSE Characteristics

Figure 34-71. Temperature Sensor Error vs. Temperature $\pm 3\sigma$



34.7 AC Characteristics

Hysteresis vs. V_{CM} and HYSMODE

Figure 34-72. Hysteresis over CM Voltage and HYSMODE at $V_{DD} = 5V$ and Temperature 25°C in Low Power Mode Disabled

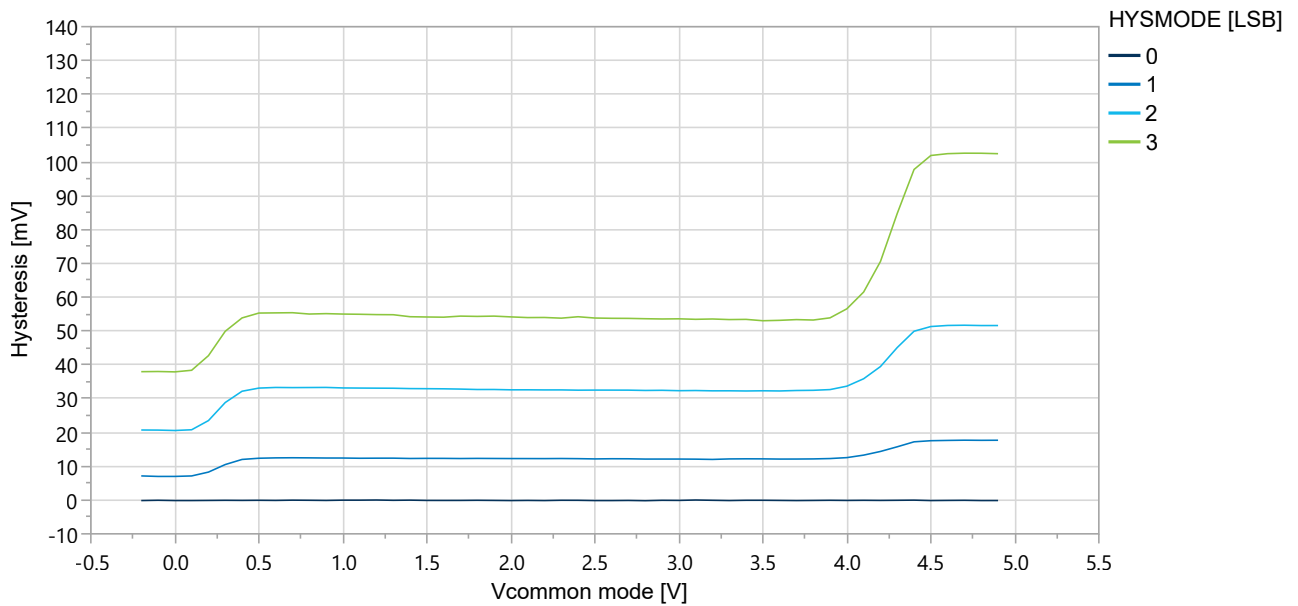
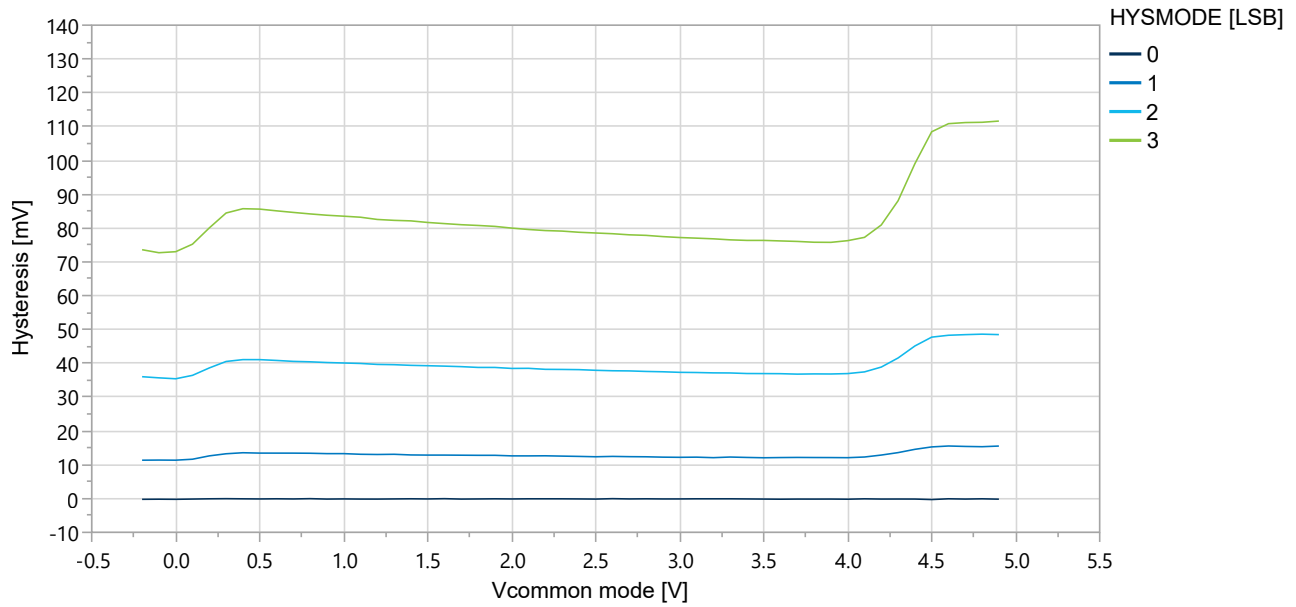

Figure 34-73. Hysteresis over CM voltage and HYSMODE at $V_{DD} = 5V$ and Temperature 25C in Low Power Mode Enabled



Hysteresis vs. V_{CM} and Temperature

Figure 34-74. Hysteresis over CM Voltage and Temperature at $V_{DD} = 5V$ and HYSMODE = 0x1 in Low Power Mode Disabled

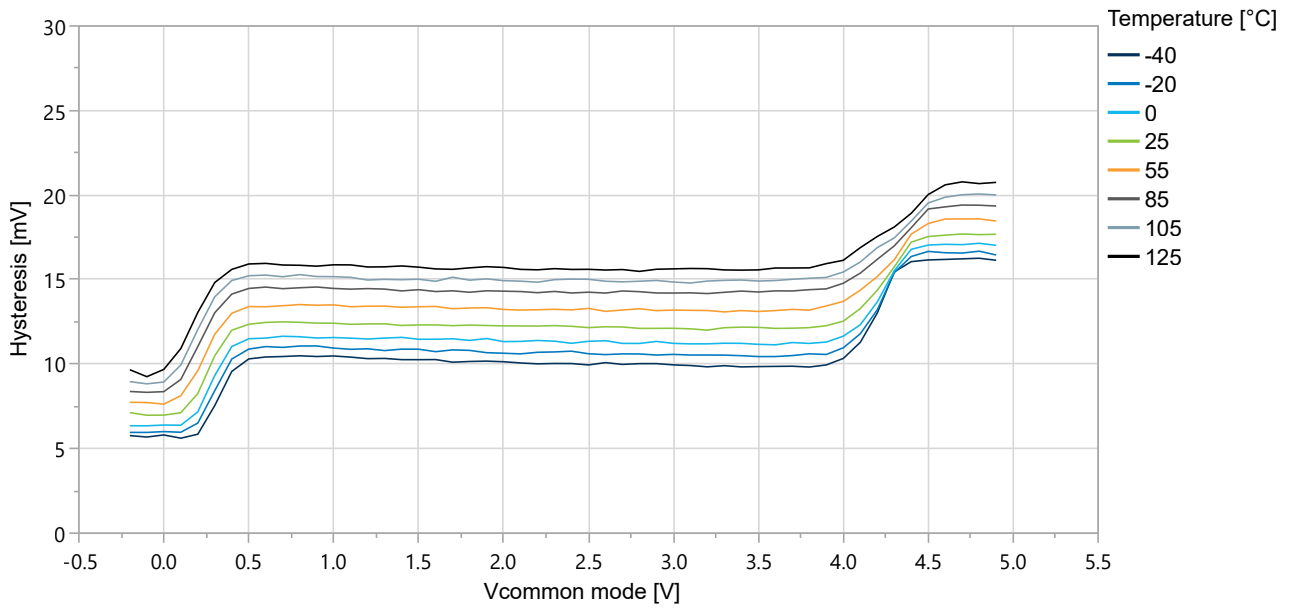

Figure 34-75. Hysteresis over CM Voltage and Temperature at $V_{DD} = 5V$ and HYSMODE = 0x1 in Low Power Mode Enabled

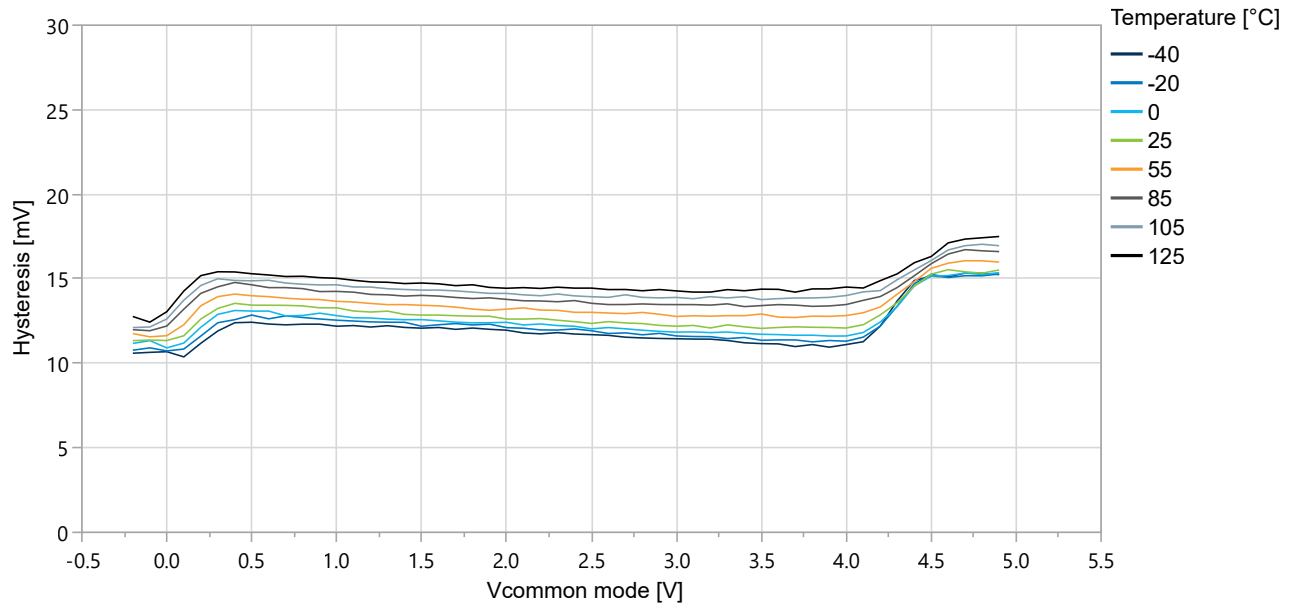

Figure 34-76. Hysteresis over CM Voltage and Temperature at $V_{DD} = 5V$ and HYSMODE = 0x2 in Low Power Mode Disabled

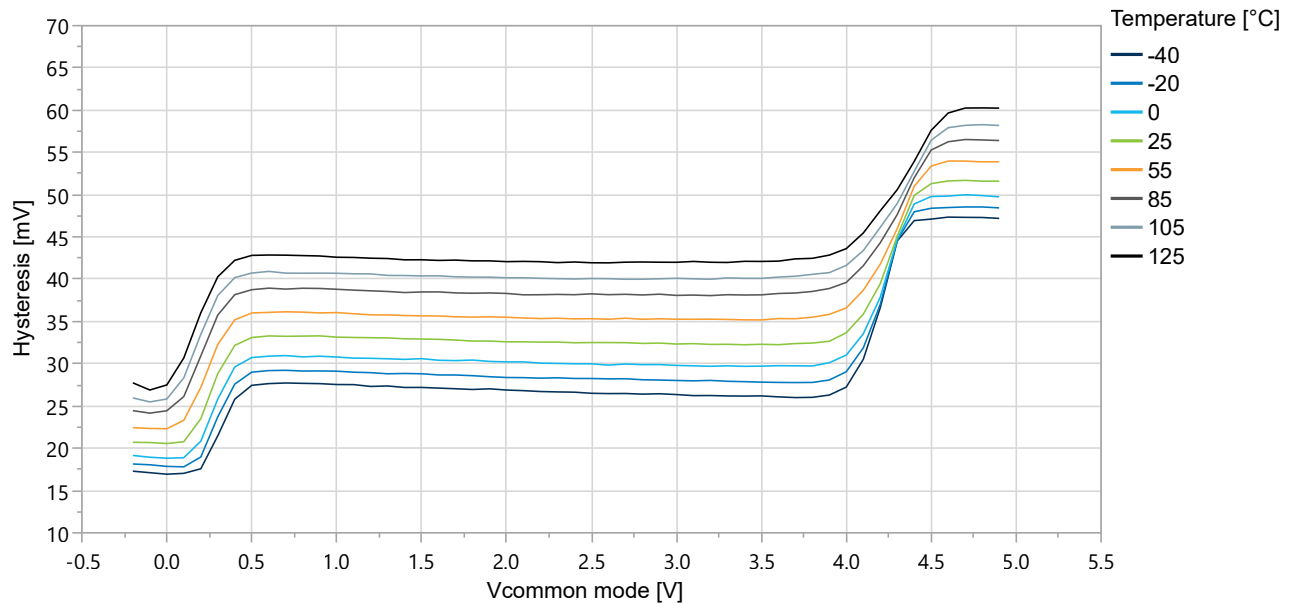

Figure 34-77. Hysteresis over CM Voltage and Temperature at $V_{DD} = 5V$ and $HYSMODE = 0x2$ in Low Power Mode Enabled

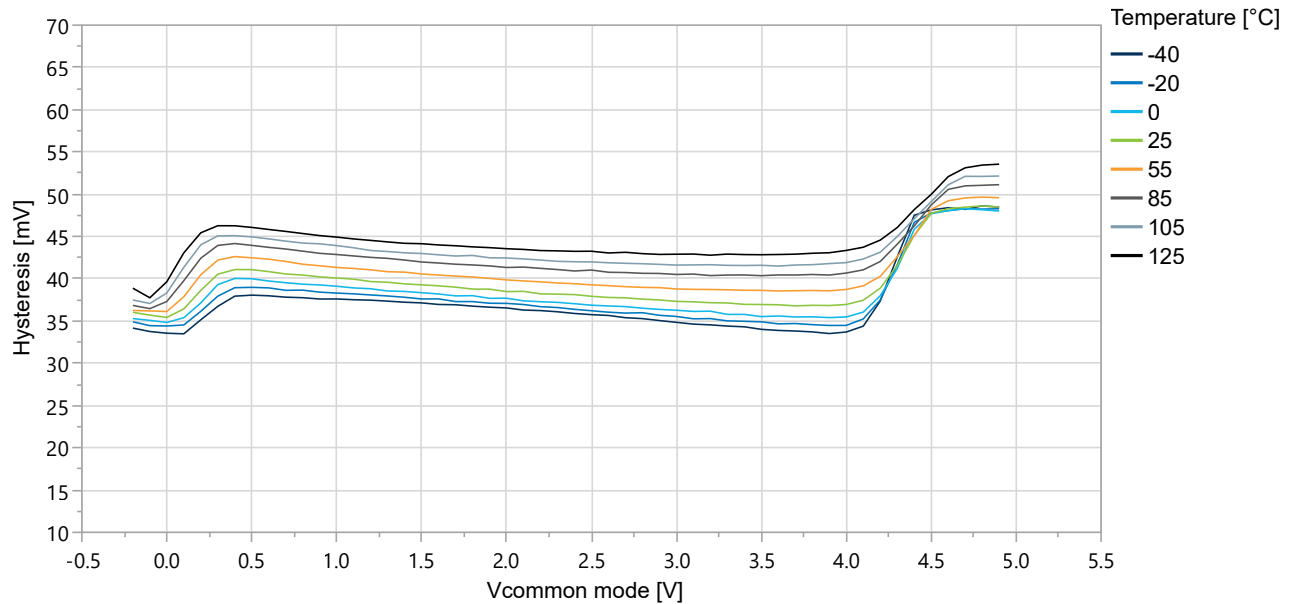

Figure 34-78. Hysteresis over CM Voltage and Temperature at $V_{DD} = 5V$ and $HYSMODE = 0x3$ in Low Power Mode Disabled

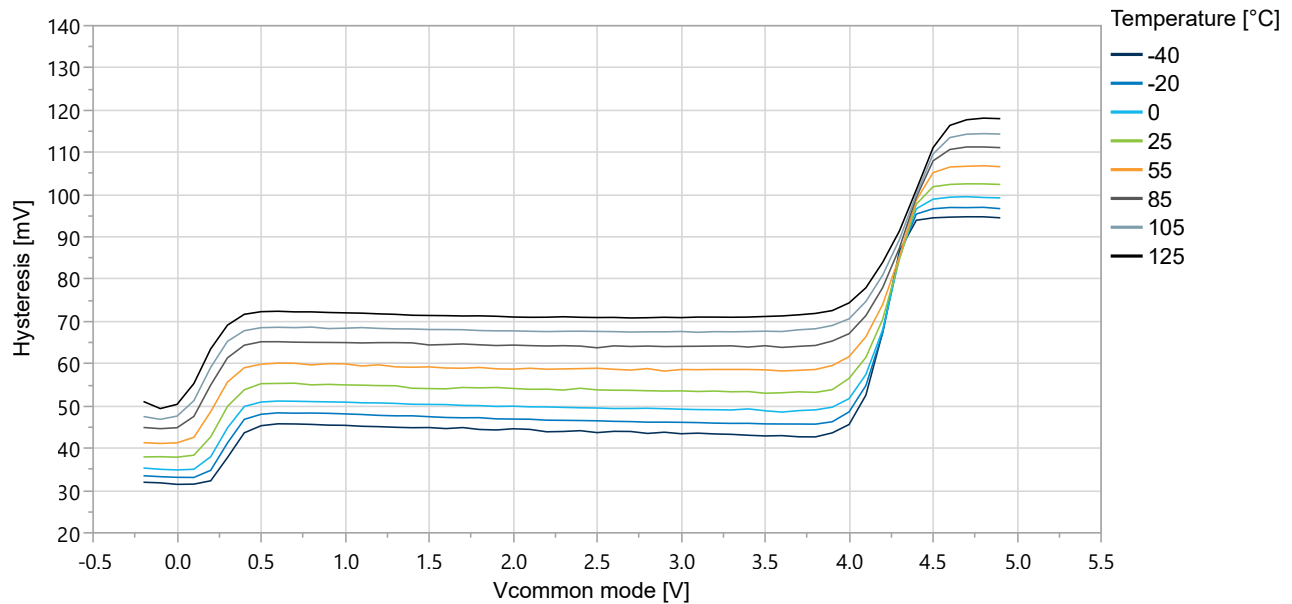
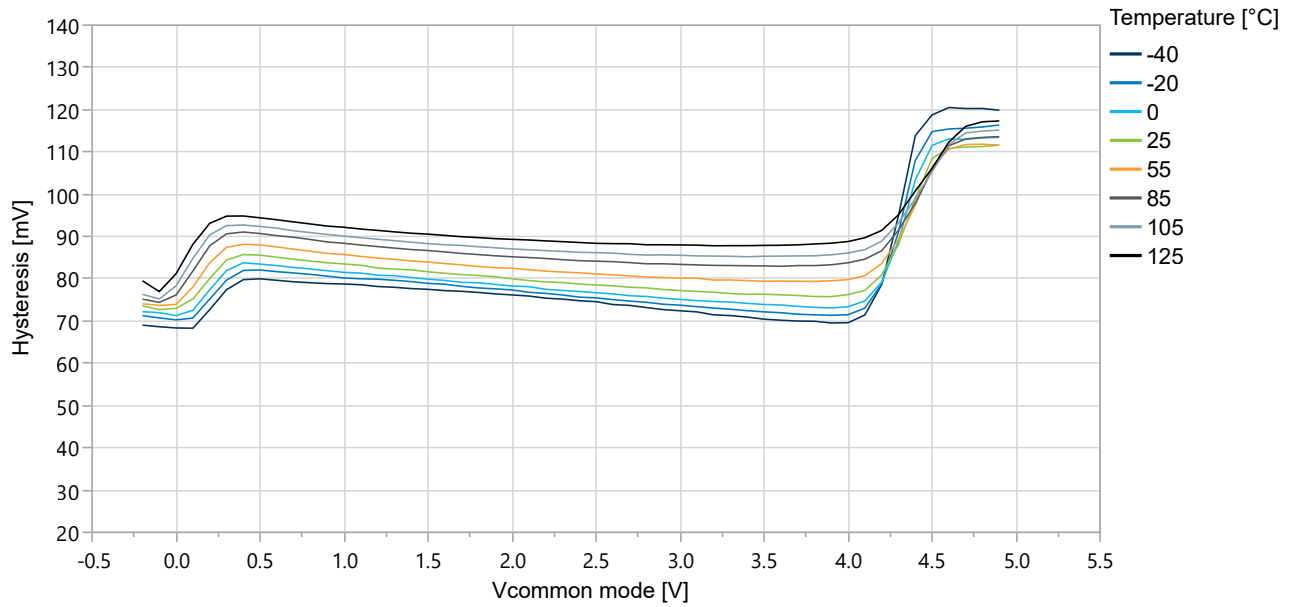

Figure 34-79. Hysteresis over CM Voltage and Temperature at $V_{DD} = 5V$ and HYSMODE = 0x3 in Low Power Mode Enabled



Offset over CM Voltage

Figure 34-80. Offset over CM Voltage and HYSMODE at $V_{DD} = 5V$ and Temperature 25°C in Low Power Mode Disabled

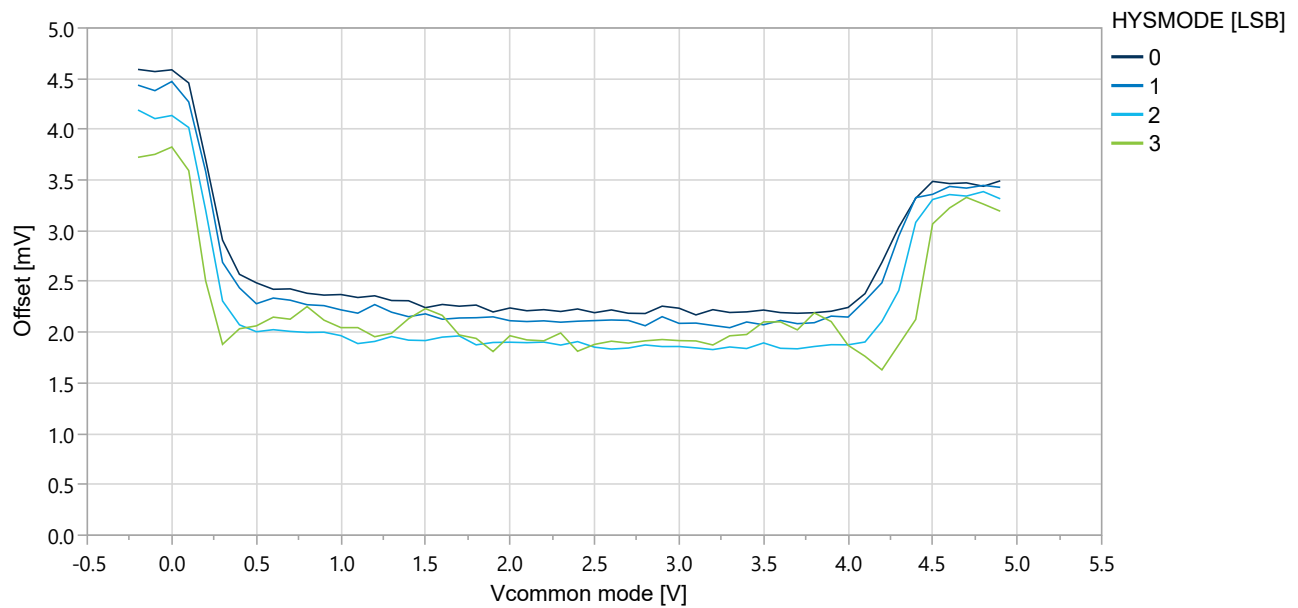

Figure 34-81. Offset over CM Voltage and HYSMODE at $V_{DD} = 5V$ and Temperature $25^{\circ}C$ in Low Power Mode Enabled

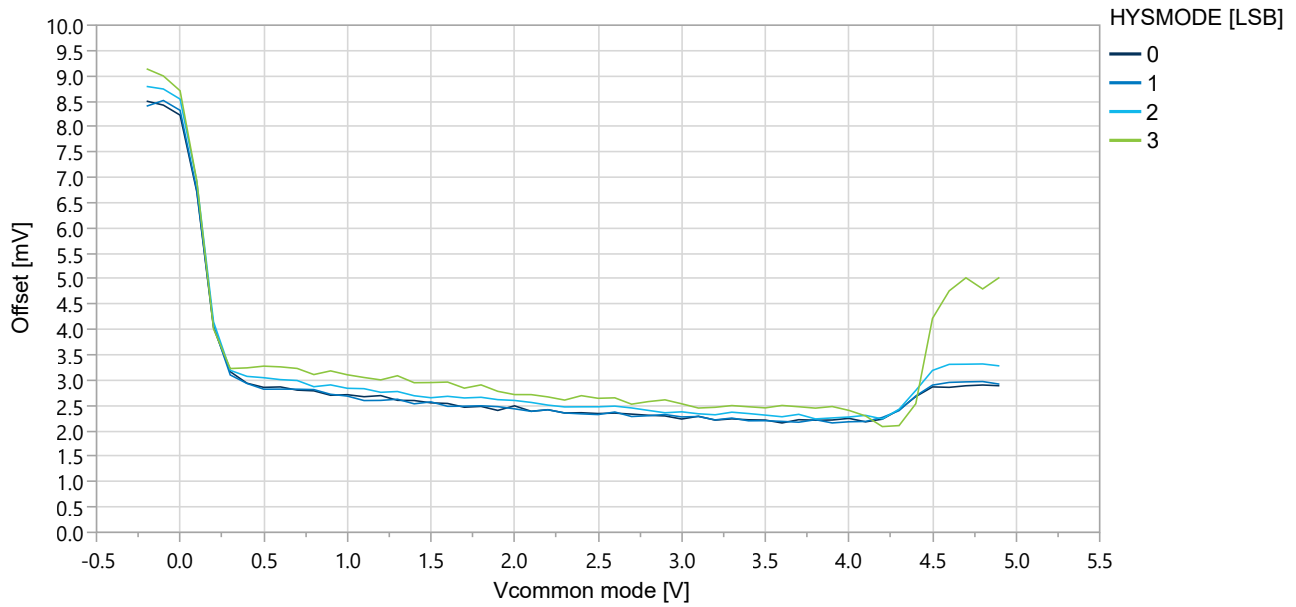

Figure 34-82. Offset over CM Voltage and Temperature at $V_{DD} = 5V$ and HYSMODE = 0x1 in Low Power Mode Disabled

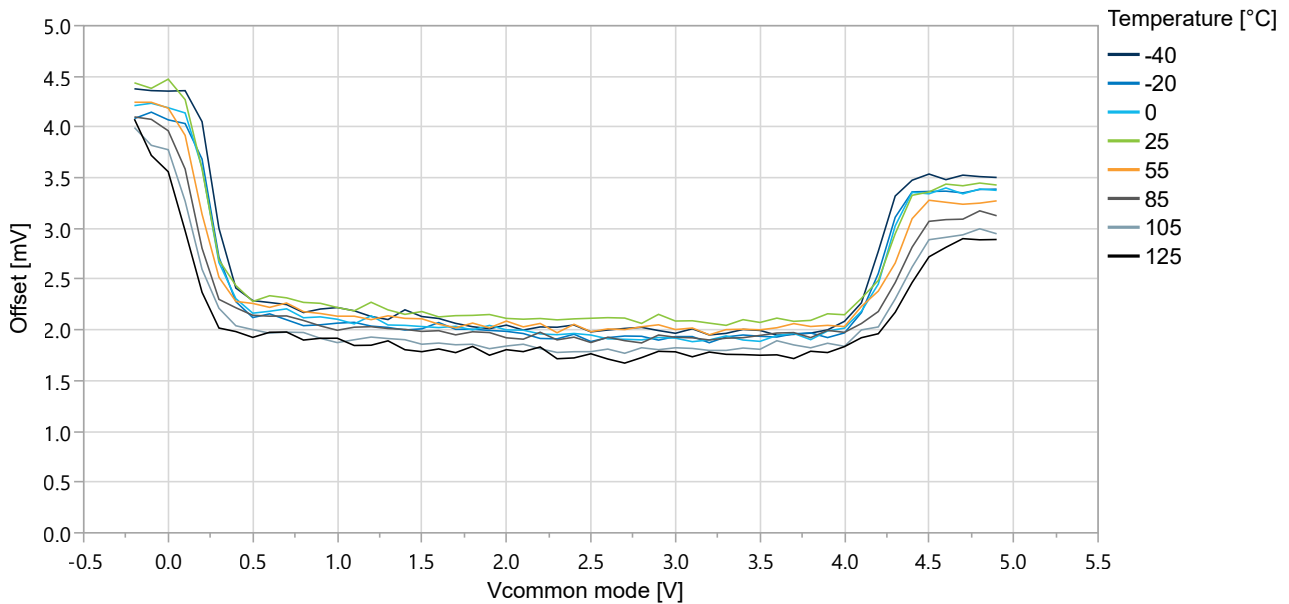
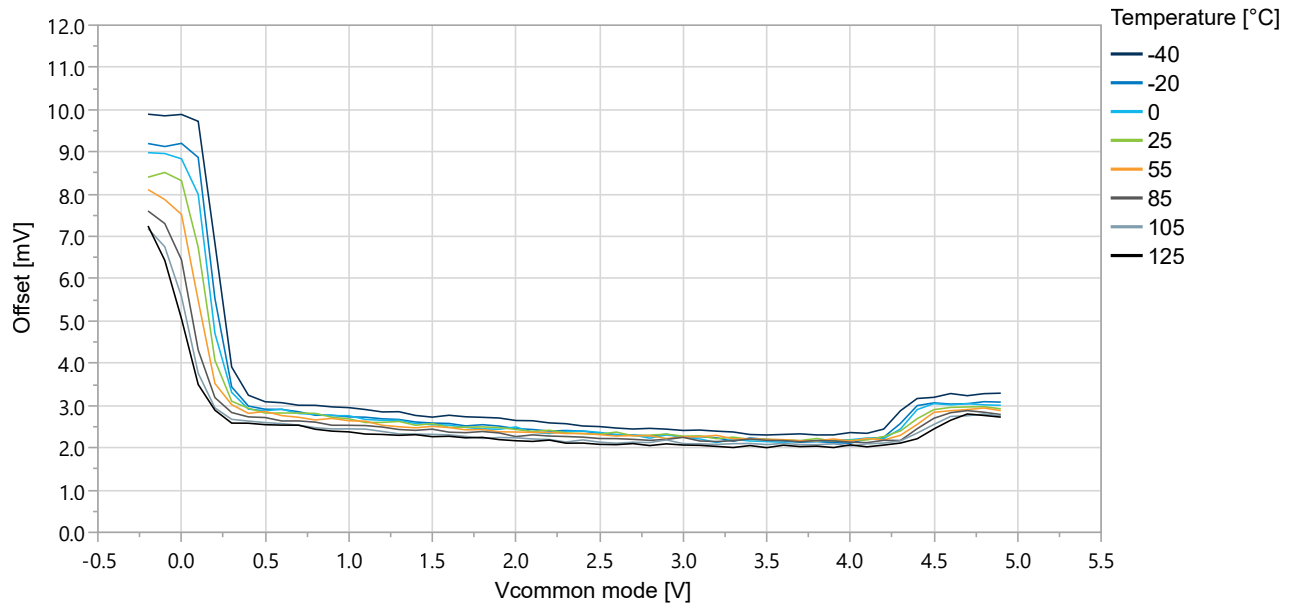

Figure 34-83. Offset over CM Voltage and Temperature at $V_{DD} = 5V$ and HYSMODE = 0x1 in Low Power Mode Enabled



34.8 OSC20M Characteristics

Figure 34-84. OSC20M Internal Oscillator: Calibration Stepsize vs. Calibration Value ($V_{DD} = 3V$)

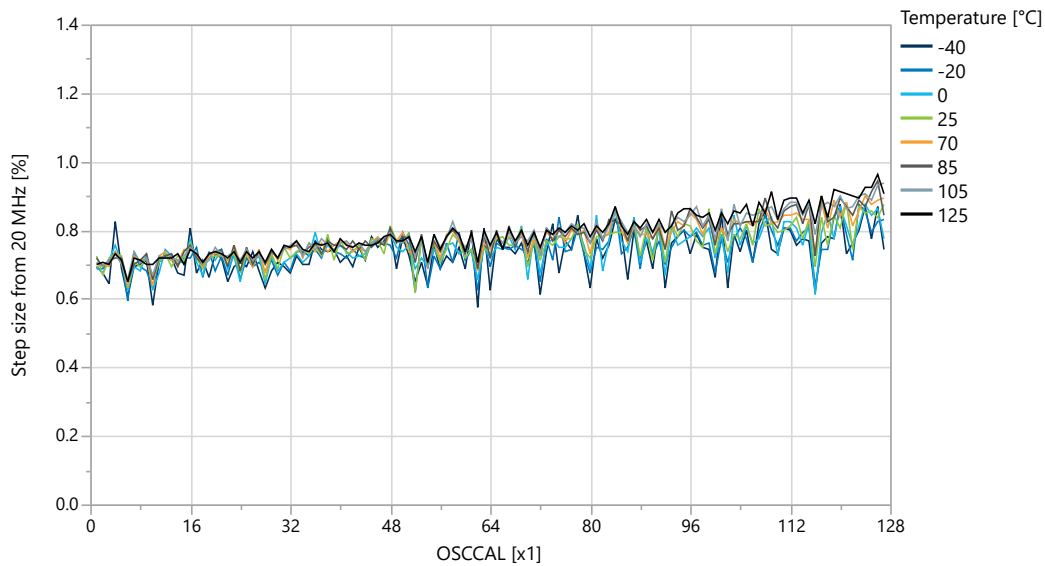

Figure 34-85. OSC20M Internal Oscillator: Frequency vs. Calibration Value ($V_{DD} = 3V$)

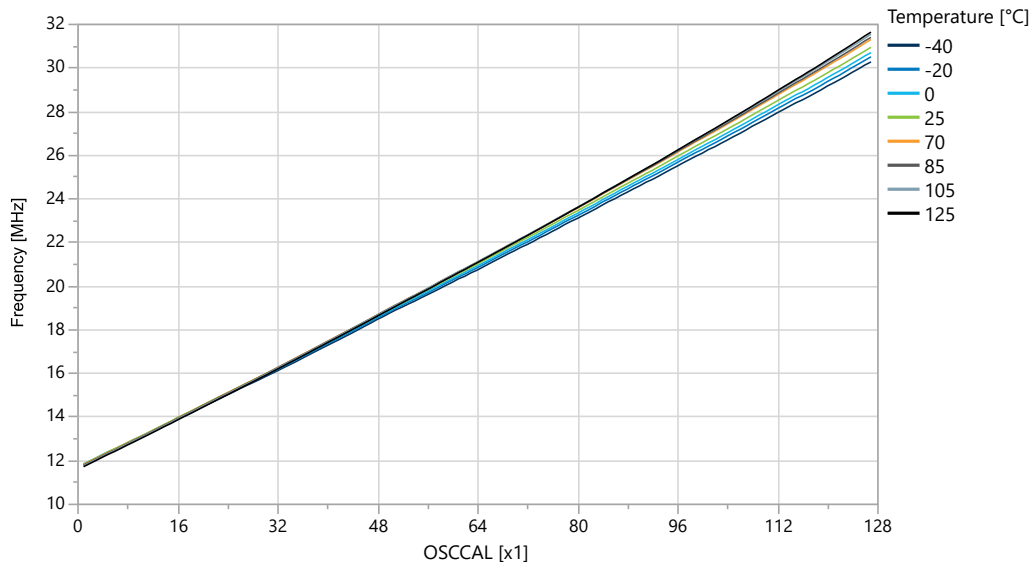

Figure 34-86. OSC20M Internal Oscillator: Frequency vs. Temperature

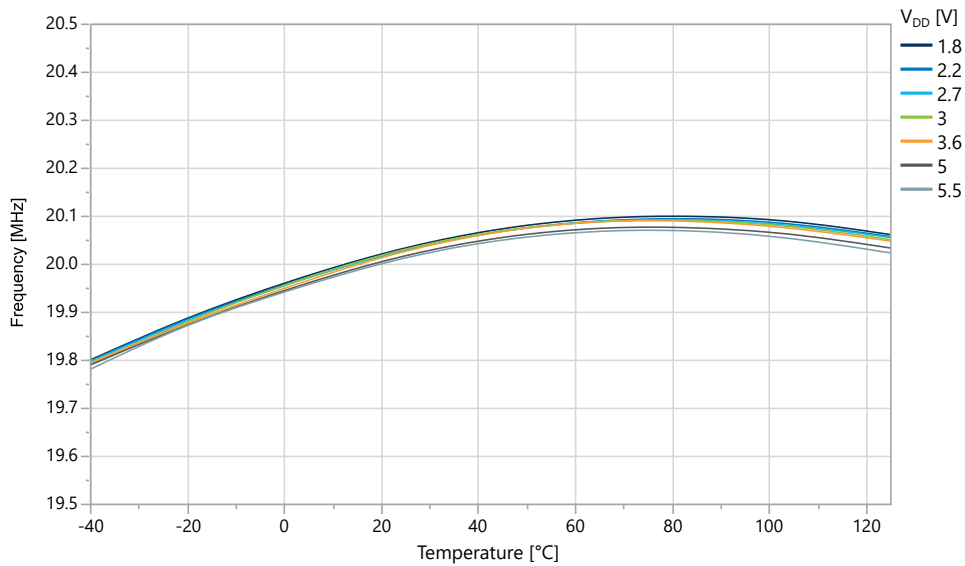
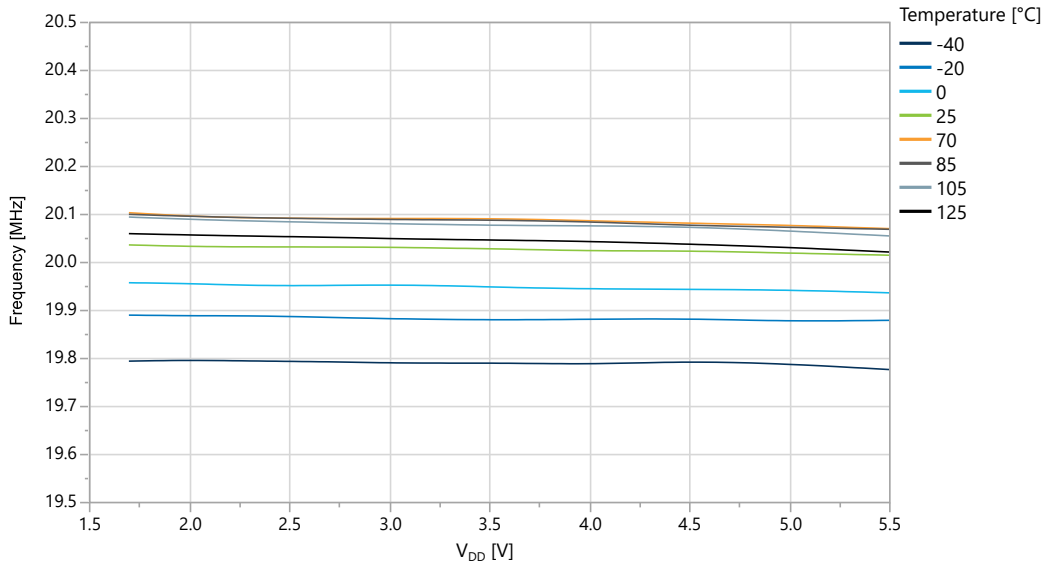

Figure 34-87. OSC20M Internal Oscillator: Frequency vs. V_{DD}



34.9 OSCULP32K Characteristics

Figure 34-88. OSCULP32K Internal Oscillator: Frequency vs. Temperature

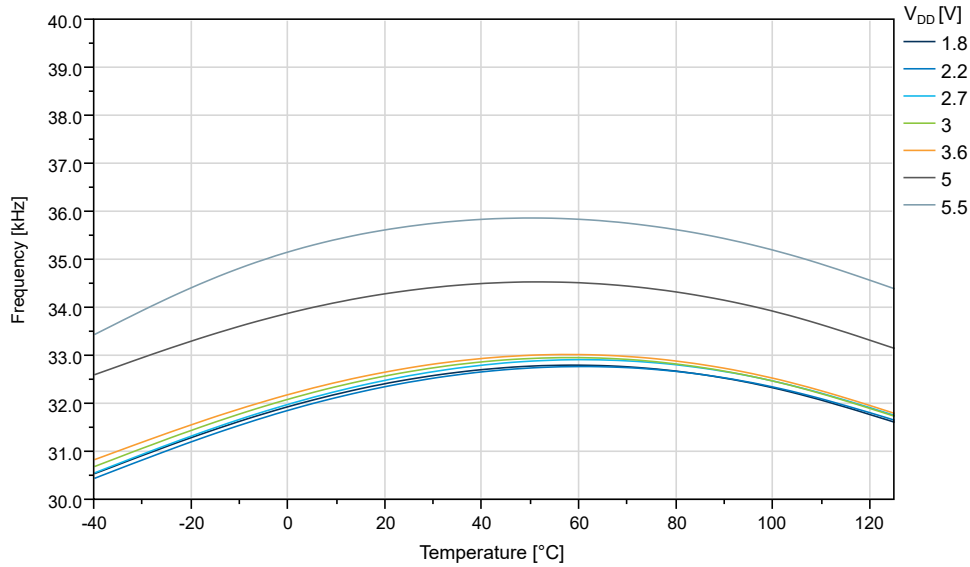
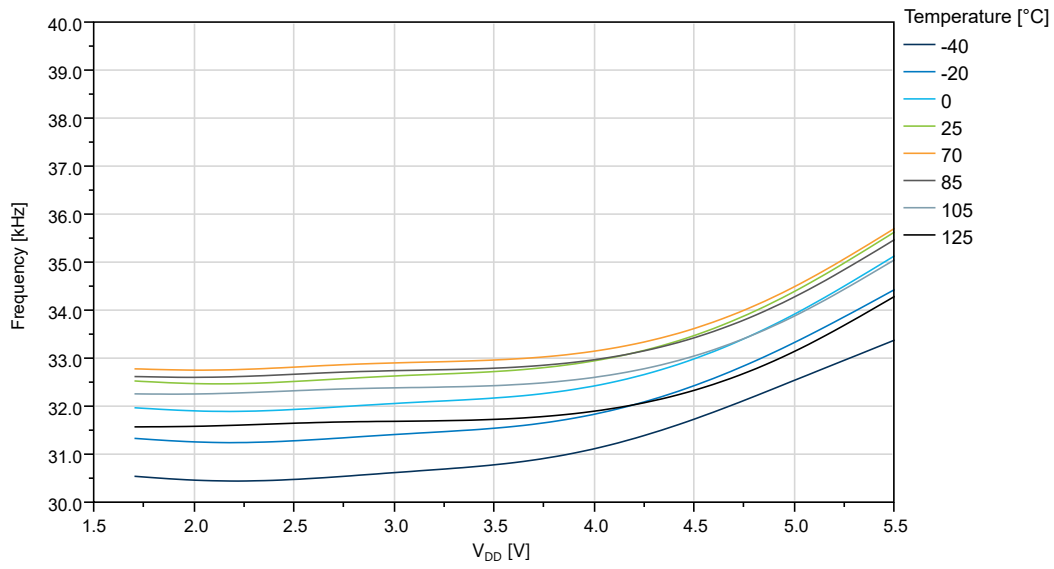

Figure 34-89. OSCULP32K Internal Oscillator: Frequency vs. V_{DD}



35. Ordering Information

Available ordering options can be found by:

- Clicking on one of the following product page links
 - [ATtiny3227 Product Page](#)
 - [ATtiny3226 Product Page](#)
 - [ATtiny3224 Product Page](#)
- Searching by product name at microchipdirect.com
- Contacting your local sales representative

Note: Automotive-grade ordering codes (VAO suffix) are set up on request and not listed in the table below. Contact your local Microchip sales representative to request VAO ordering codes not present on the respective product page.

Table 35-1. Available Product Numbers

Ordering Code ⁽¹⁾	Flash/SRAM	Pin Count	Package Type ⁽²⁾	Supply Voltage	Temperature Range	Carrier Type
ATTINY3224-SSF	32 KB/3 KB	14	SOIC	1.8-5.5V	-40°C to +125°C	Tube
ATTINY3224-SSFR	32 KB/3 KB	14	SOIC	1.8-5.5V	-40°C to +125°C	Tape & Reel
ATTINY3224-SSU	32 KB/3 KB	14	SOIC	1.8-5.5V	-40°C to +85°C	Tube
ATTINY3224-SSUR	32 KB/3 KB	14	SOIC	1.8-5.5V	-40°C to +85°C	Tape & Reel
ATTINY3224-XF	32 KB/3 KB	14	TSSOP	1.8-5.5V	-40°C to +125°C	Tube
ATTINY3224-XFR	32 KB/3 KB	14	TSSOP	1.8-5.5V	-40°C to +125°C	Tape & Reel
ATTINY3224-XU	32 KB/3 KB	14	TSSOP	1.8-5.5V	-40°C to +85°C	Tube
ATTINY3224-XUR	32 KB/3 KB	14	TSSOP	1.8-5.5V	-40°C to +85°C	Tape & Reel
ATTINY3226-MFR	32 KB/3 KB	20	VQFN	1.8-5.5V	-40°C to +125°C	Tape & Reel
ATTINY3226-MU	32 KB/3 KB	20	VQFN	1.8-5.5V	-40°C to +85°C	Tray
ATTINY3226-MUR	32 KB/3 KB	20	VQFN	1.8-5.5V	-40°C to +85°C	Tape & Reel
ATTINY3226-SF	32 KB/3 KB	20	SOIC	1.8-5.5V	-40°C to +125°C	Tube
ATTINY3226-SFR	32 KB/3 KB	20	SOIC	1.8-5.5V	-40°C to +125°C	Tape & Reel
ATTINY3226-SU	32 KB/3 KB	20	SOIC	1.8-5.5V	-40°C to +85°C	Tube
ATTINY3226-SUR	32 KB/3 KB	20	SOIC	1.8-5.5V	-40°C to +85°C	Tape & Reel
ATTINY3226-XF	32 KB/3 KB	20	SSOP	1.8-5.5V	-40°C to +125°C	Tube
ATTINY3226-XFR	32 KB/3 KB	20	SSOP	1.8-5.5V	-40°C to +125°C	Tape & Reel
ATTINY3226-XU	32 KB/3 KB	20	SSOP	1.8-5.5V	-40°C to +85°C	Tube
ATTINY3226-XUR	32 KB/3 KB	20	SSOP	1.8-5.5V	-40°C to +85°C	Tape & Reel
ATTINY3227-MU	32 KB/3 KB	20	VQFN	1.8-5.5V	-40°C to +85°C	Tray
ATTINY3226-MF	32 KB/3 KB	24	VQFN	1.8-5.5V	-40°C to +125°C	Tray
ATTINY3227-MF	32 KB/3 KB	24	VQFN	1.8-5.5V	-40°C to +125°C	Tray
ATTINY3227-MFR	32 KB/3 KB	24	VQFN	1.8-5.5V	-40°C to +125°C	Tape & Reel
ATTINY3227-MUR	32 KB/3 KB	24	VQFN	1.8-5.5V	-40°C to +85°C	Tape & Reel

Notes:

1. Pb-free packing complies with the European Directive for Restrictions of Hazardous Substances (RoHS directive). Also halide-free and completely green.
2. Package outline drawings can be found in the *Package Drawings* section.

Product Identification System

To order or obtain information, e.g., on pricing or delivery, refer to the factory or the listed sales office.

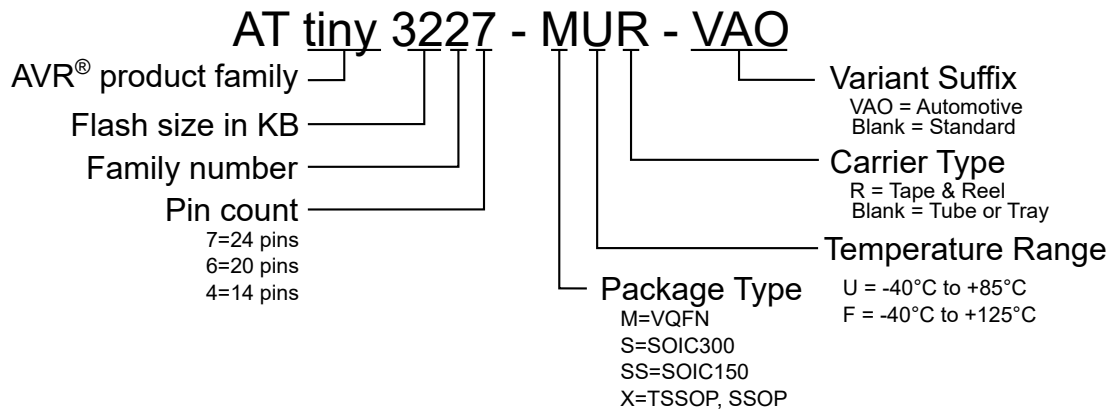

Note: The Tape & Reel identifier only appears in the catalog part number description. Use this identifier for ordering purposes. Check with your Microchip Sales Office for package availability with the Tape and Reel option.

Note: The VAO variants have been designed, manufactured, tested, and qualified per AEC-Q100 requirements for automotive applications. These products may use a different package than non-VAO parts and have additional specifications in their Electrical Characteristics.

36. Package Drawings

36.1 Online Package Drawings

For the most recent package drawings:

1. Go to www.microchip.com/packaging.
2. Go to the package type-specific page, for example VQFN.
3. Search for the Drawing Number and Style to find the most recent package drawings.

Table 36-1. Drawing Numbers

Pin Count	Package Type	Drawing Number	Style
14	SOIC	C04-00065	SL
14	TSSOP	C04-00087	ST
20	SOIC	C04-00094	SO
20	SSOP	C04-00072	SS
20	VQFN	C04-21380	REB
20	VQFN ⁽¹⁾	C04-00476	2LX
24	VQFN	C04-21386	RLB
24	VQFN ⁽¹⁾	C04-21483	U3B

Note:

1. This package type has wettable flanks and will only be available for automotive (VAO) ordering codes.

36.2 Package Marking Information

<p>Legend:</p> <p>XX...X Customer-specific information or Microchip part number</p> <p>Y Year code (last digit of calendar year)</p> <p>YY Year code (last 2 digits of calendar year)</p> <p>WW Week code (week of January 1 is week '01')</p> <p>NNN Alphanumeric traceability code</p> <p>Ⓔ3 Pb-free JEDEC[®] designator for Matte Tin (Sn)</p>	<p>Note: In the event the full Microchip part number cannot be marked on one line, it will be carried over to the next line, thus limiting the number of available characters for customer-specific information.</p>
--	---

36.2.1 14-Pin SOIC

Figure 36-1. General

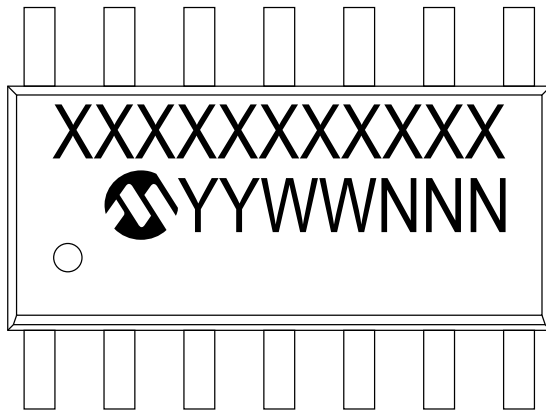
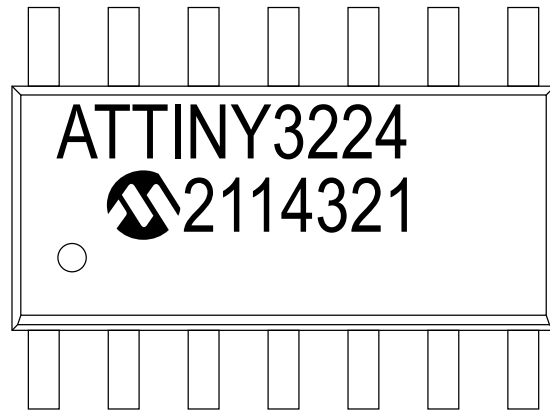

Figure 36-2. Example



36.2.2 14-Pin TSSOP

Figure 36-3. General

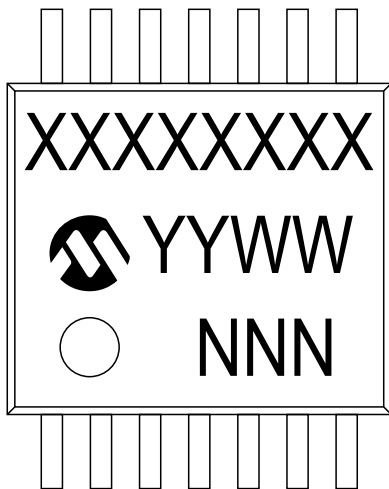
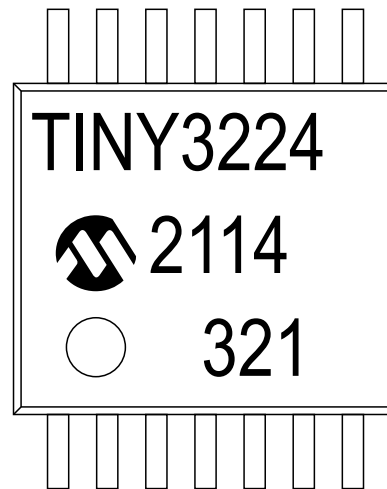

Figure 36-4. Example



36.2.3 20-Pin SOIC

Figure 36-5. General

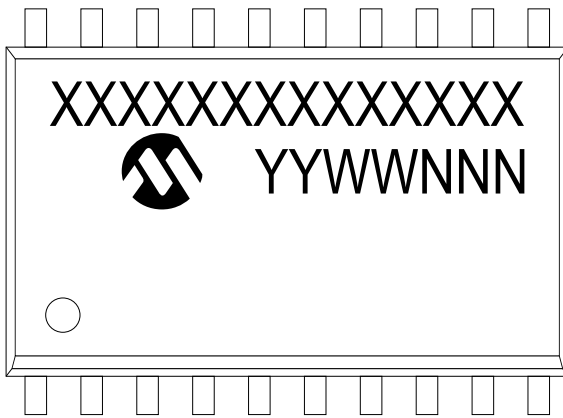

Figure 36-6. Example



36.2.4 20-Pin SSOP

Figure 36-7. General

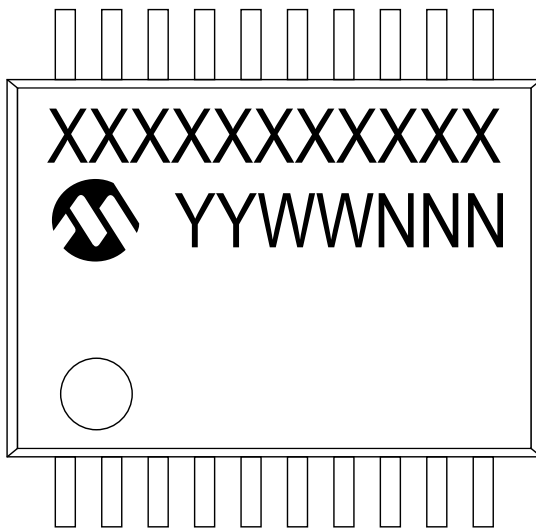
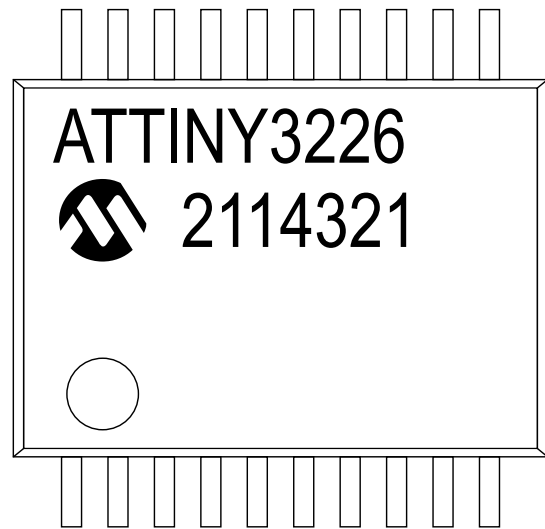

Figure 36-8. Example



36.2.5 20-Pin VQFN

Figure 36-9. General

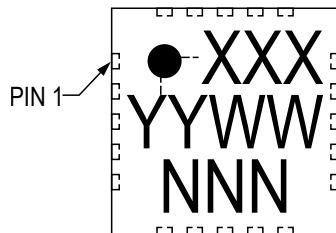
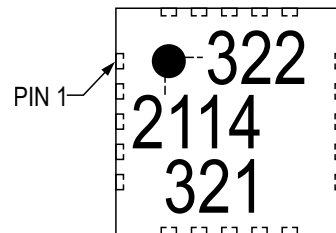

Figure 36-10. Example



36.2.6 20-Pin VQFN Wettable Flanks

Figure 36-11. General

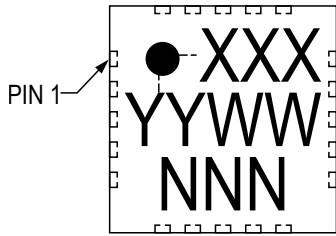
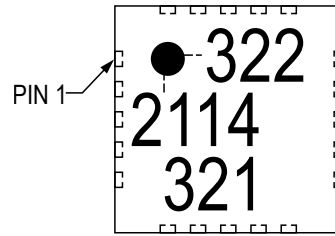

Figure 36-12. Example



36.2.7 24-Pin VQFN

Figure 36-13. General

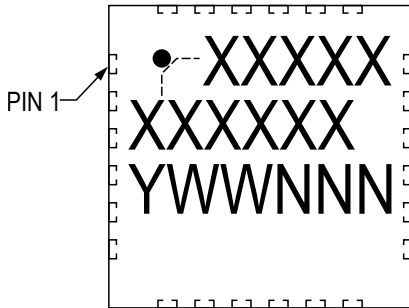
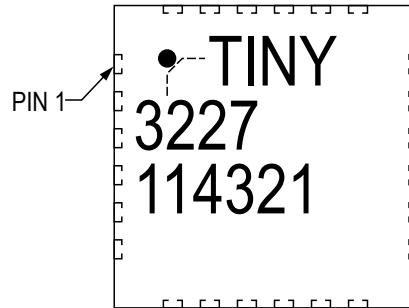

Figure 36-14. Example



36.2.8 24-Pin VQFN Wettable Flanks

Figure 36-15. General

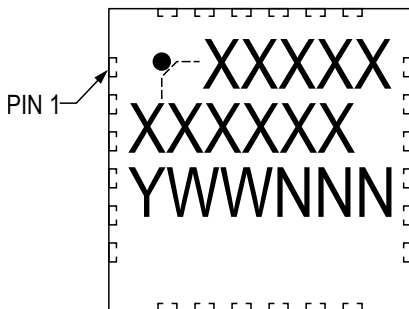
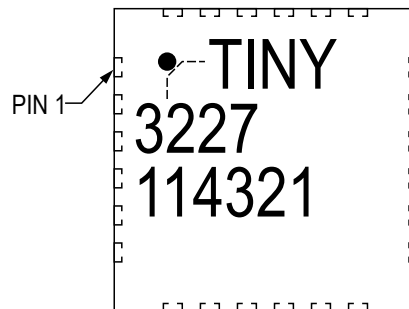

Figure 36-16. Example



36.3 14-Pin SOIC

14-Lead Plastic Small Outline (SL) - Narrow, 3.90 mm Body [SOIC]

Note: For the most current package drawings, please see the Microchip Packaging Specification located at <http://www.microchip.com/packaging>

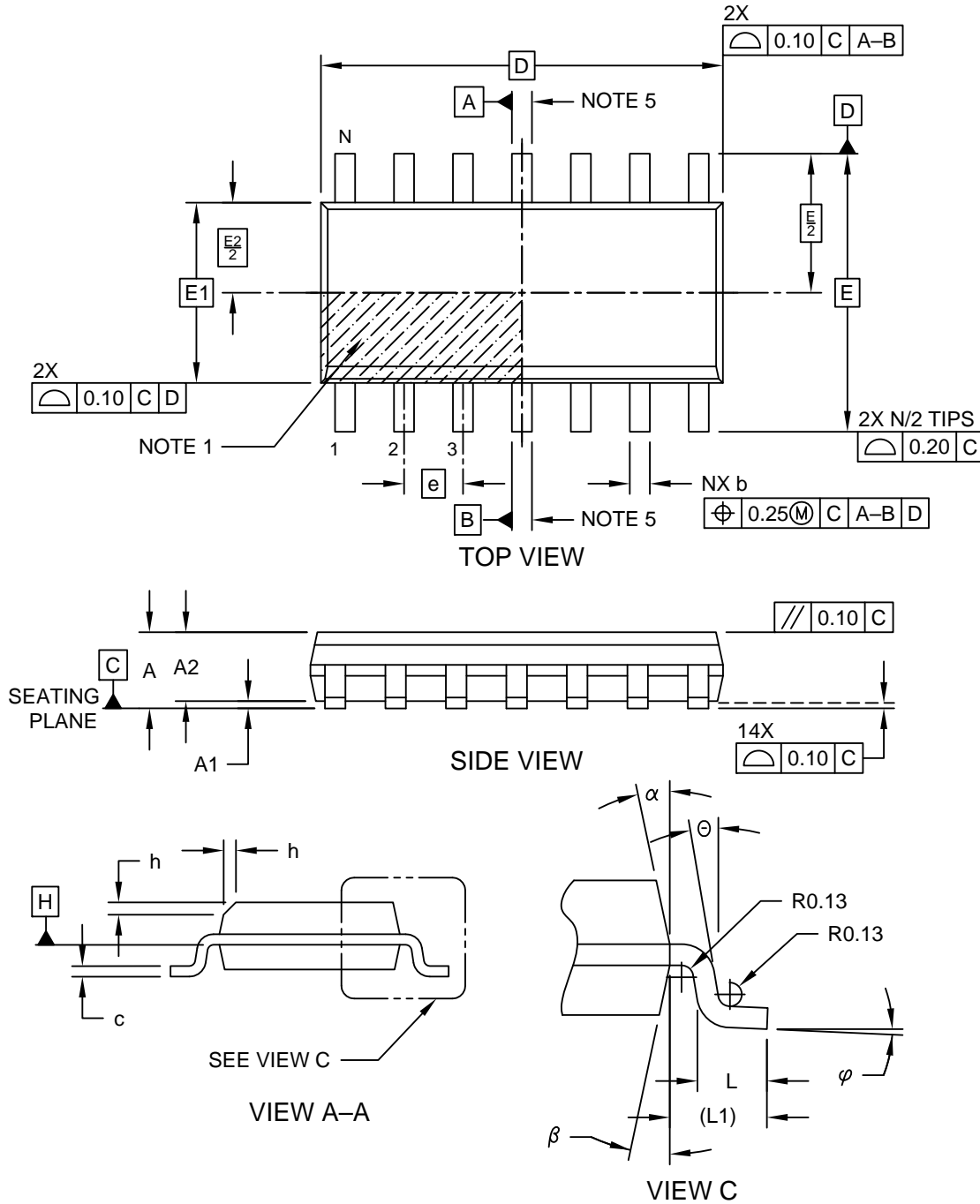

Microchip Technology Drawing No. C04-065-SL Rev D Sheet 1 of 2

14-Lead Plastic Small Outline (SL) - Narrow, 3.90 mm Body [SOIC]

Note: For the most current package drawings, please see the Microchip Packaging Specification located at <http://www.microchip.com/packaging>

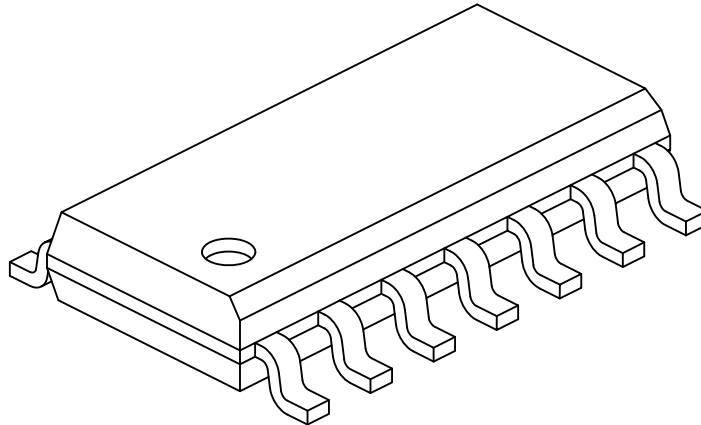

		Units	MILLIMETERS		
Dimension Limits			MIN	NOM	MAX
Number of Pins	N		14		
Pitch	e		1.27 BSC		
Overall Height	A	-	-	-	1.75
Molded Package Thickness	A2	1.25	-	-	-
Standoff §	A1	0.10	-	-	0.25
Overall Width	E		6.00 BSC		
Molded Package Width	E1		3.90 BSC		
Overall Length	D		8.65 BSC		
Chamfer (Optional)	h	0.25	-	-	0.50
Foot Length	L	0.40	-	-	1.27
Footprint	L1		1.04 REF		
Lead Angle	Θ	0°	-	-	-
Foot Angle	φ	0°	-	-	8°
Lead Thickness	c	0.10	-	-	0.25
Lead Width	b	0.31	-	-	0.51
Mold Draft Angle Top	α	5°	-	-	15°
Mold Draft Angle Bottom	β	5°	-	-	15°

Notes:

1. Pin 1 visual index feature may vary, but must be located within the hatched area.
2. § Significant Characteristic
3. Dimension D does not include mold flash, protrusions or gate burrs, which shall not exceed 0.15 mm per end. Dimension E1 does not include interlead flash or protrusion, which shall not exceed 0.25 mm per side.
4. Dimensioning and tolerancing per ASME Y14.5M
 - BSC: Basic Dimension. Theoretically exact value shown without tolerances.
 - REF: Reference Dimension, usually without tolerance, for information purposes only.
5. Datums A & B to be determined at Datum H.

Microchip Technology Drawing No. C04-065-SL Rev D Sheet 2 of 2

14-Lead Plastic Small Outline (SL) - Narrow, 3.90 mm Body [SOIC]

Note: For the most current package drawings, please see the Microchip Packaging Specification located at <http://www.microchip.com/packaging>

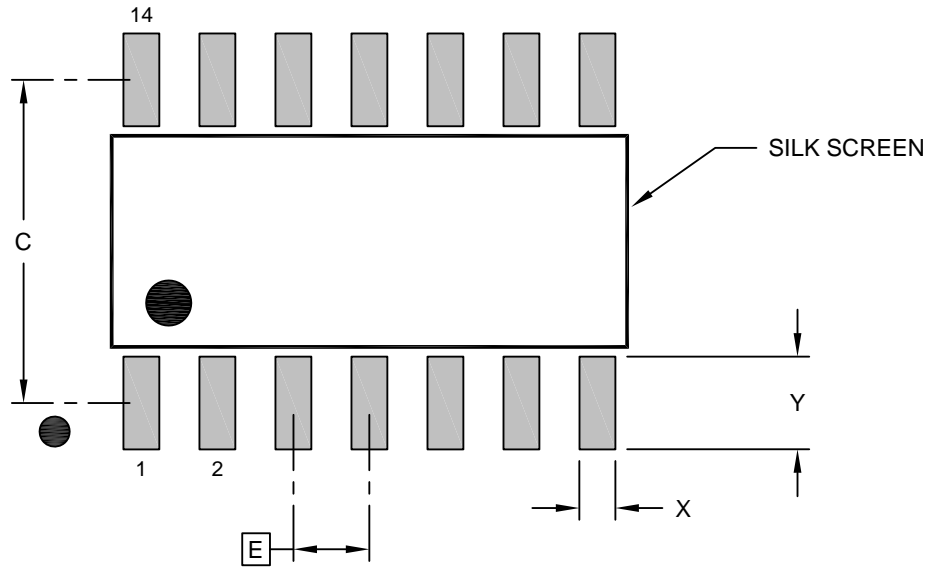

RECOMMENDED LAND PATTERN

Dimension Limits	Units	MILLIMETERS		
		MIN	NOM	MAX
Contact Pitch	E		1.27 BSC	
Contact Pad Spacing	C		5.40	
Contact Pad Width (X14)	X			0.60
Contact Pad Length (X14)	Y			1.55

Notes:

- Dimensioning and tolerancing per ASME Y14.5M
BSC: Basic Dimension. Theoretically exact value shown without tolerances.

Microchip Technology Drawing No. C04-2065-SL Rev D

36.4 14-Pin TSSOP

14Lead Thin Shrink Small Outline Package [ST] 4.4 mm Body [TSSOP]

Note: For the most current package drawings, please see the Microchip Packaging Specification located at <http://www.microchip.com/packaging>

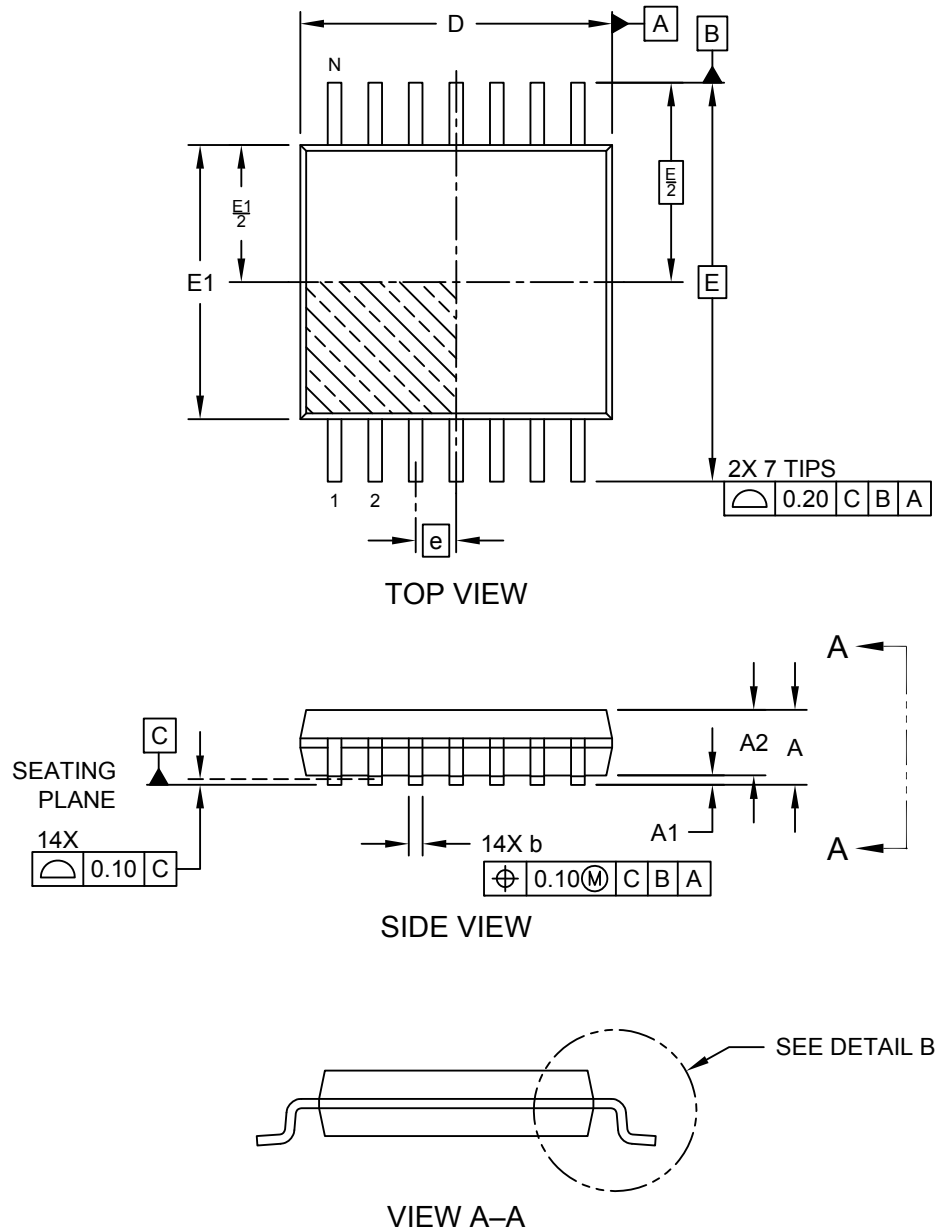

14Lead Thin Shrink Small Outline Package [ST] 4.4 mm Body [TSSOP]

Note: For the most current package drawings, please see the Microchip Packaging Specification located at <http://www.microchip.com/packaging>

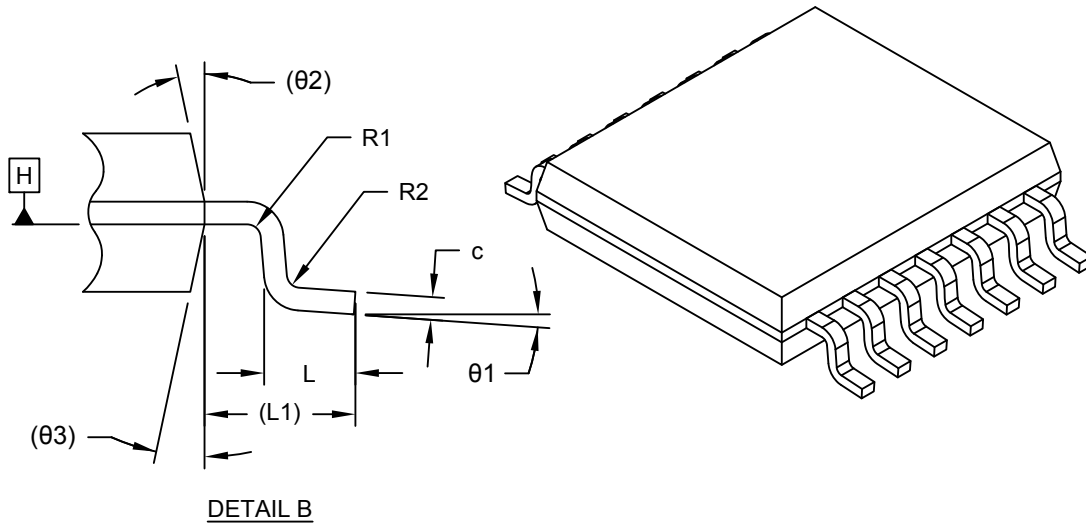

Dimension	Units	MILLIMETERS		
		MIN	NOM	MAX
Number of Terminals	N	14		
Pitch	e	0.65 BSC		
Overall Height	A	-	-	1.20
Standoff	A1	0.05	-	0.15
Molded Package Thickness	A2	0.80	1.00	1.05
Overall Length	D	4.90	5.00	5.10
Overall Width	E	6.40 BSC		
Molded Package Width	E1	4.30	4.40	4.50
Terminal Width	b	0.19	-	0.30
Terminal Thickness	c	0.09	-	0.20
Terminal Length	L	0.45	0.60	0.75
Footprint	L1	1.00 REF		
Lead Bend Radius	R1	0.09	-	-
Lead Bend Radius	R2	0.09	-	-
Foot Angle	theta1	0°	-	8°
Mold Draft Angle	theta2	-	12° REF	-
Mold Draft Angle	theta3	-	12° REF	-

Notes:

1. Pin 1 visual index feature may vary, but must be located within the hatched area.
2. Dimensioning and tolerancing per ASME Y14.5M
 BSC: Basic Dimension. Theoretically exact value shown without tolerances.
 REF: Reference Dimension, usually without tolerance, for information purposes only.

14Lead Thin Shrink Small Outline Package [ST] 4.4 mm Body [TSSOP]

Note: For the most current package drawings, please see the Microchip Packaging Specification located at <http://www.microchip.com/packaging>

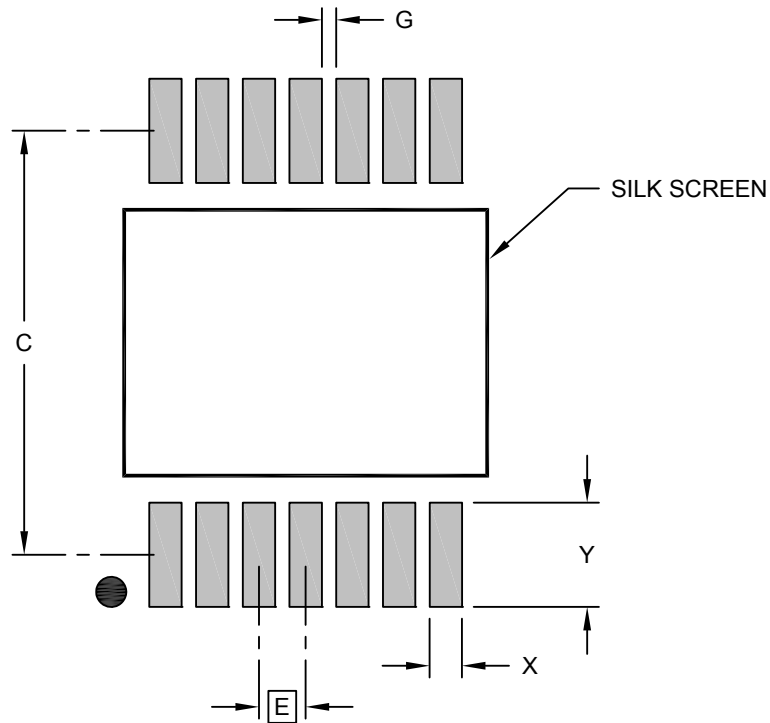

RECOMMENDED LAND PATTERN

Dimension Limits		MILLIMETERS		
		MIN	NOM	MAX
Contact Pitch	E	0.65 BSC		
Contact Pad Spacing	C		5.90	
Contact Pad Width (Xnn)	X			0.45
Contact Pad Length (Xnn)	Y			1.45
Contact Pad to Contact Pad (Xnn)	G	0.20		

Notes:

1. Dimensioning and tolerancing per ASME Y14.5M
BSC: Basic Dimension. Theoretically exact value shown without tolerances.

Microchip Technology Drawing C04-2087 Rev D

36.5 20-Pin SOIC

20-Lead Plastic Small Outline (SO) - Wide, 7.50 mm Body [SOIC]

Note: For the most current package drawings, please see the Microchip Packaging Specification located at <http://www.microchip.com/packaging>

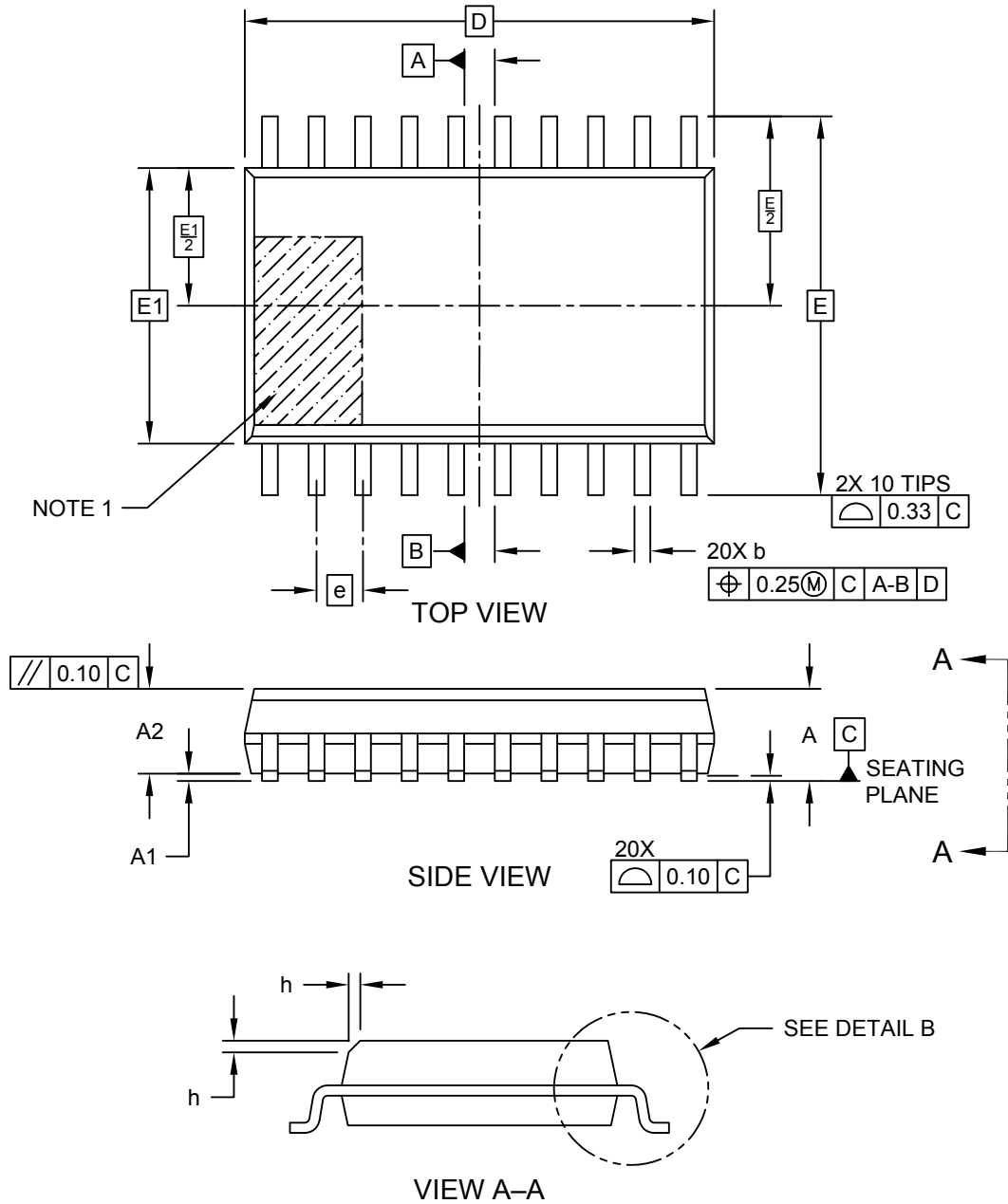

20-Lead Plastic Small Outline (SO) - Wide, 7.50 mm Body [SOIC]

Note: For the most current package drawings, please see the Microchip Packaging Specification located at <http://www.microchip.com/packaging>

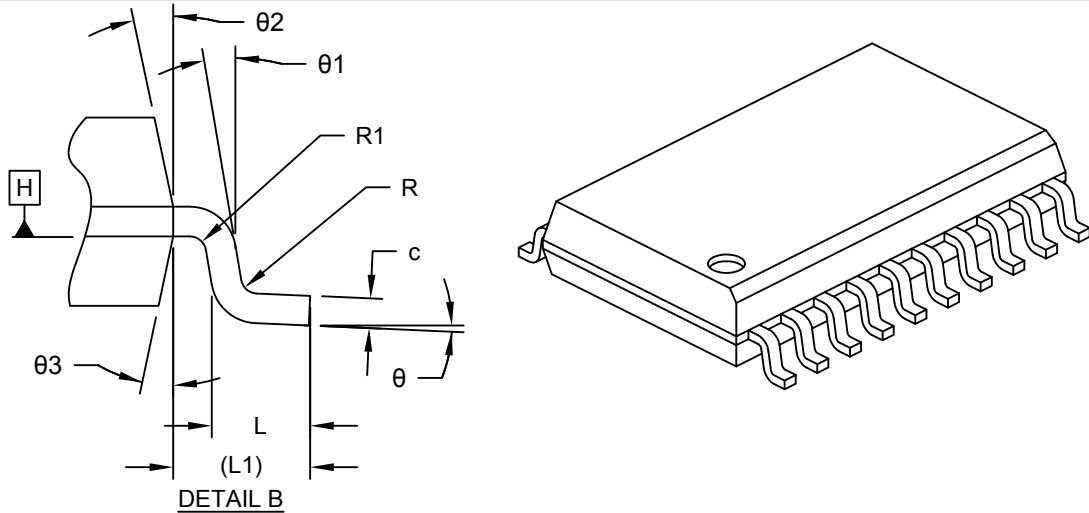

Dimension Limits	Units	MILLIMETERS		
		MIN	NOM	MAX
Number of Terminals	N	20		
Pitch	e	1.27 BSC		
Overall Height	A	-	-	2.65
Standoff §	A1	0.10	-	0.30
Molded Package Thickness	A2	2.05	-	-
Overall Length	D	12.80 BSC		
Overall Width	E	10.30 BSC		
Molded Package Width	E1	7.50 BSC		
Terminal Width	b	0.31	-	0.51
Terminal Thickness	c	0.25	-	0.75
Corner Chamfer	h	0.25	-	0.41
Terminal Length	L	0.41	0.65	0.89
Footprint	L1	1.40 REF		
Lead Bend Radius	R1	0.07	-	-
Lead Bend Radius	R2	0.07	-	-
Foot Angle	θ	0°	-	8°
Lead Angle	θ1	0°	-	-
Mold Draft Angle	θ2	5°	-	15°
Mold Draft Angle	θ3	5°	-	15°

Notes:

1. Pin 1 visual index feature may vary, but must be located within the hatched area.
2. Dimensioning and tolerancing per ASME Y14.5M
 BSC: Basic Dimension. Theoretically exact value shown without tolerances.
 REF: Reference Dimension, usually without tolerance, for information purposes only.
3. Dimension D does not include mold flash, protrusions or gate burrs, which shall not exceed 0.15 mm per end. Dimension E1 does not include interlead flash or protrusion, which shall not exceed 0.25 mm per side.
4. § Significant Characteristic

20-Lead Plastic Small Outline (SO) - Wide, 7.50 mm Body [SOIC]

Note: For the most current package drawings, please see the Microchip Packaging Specification located at <http://www.microchip.com/packaging>

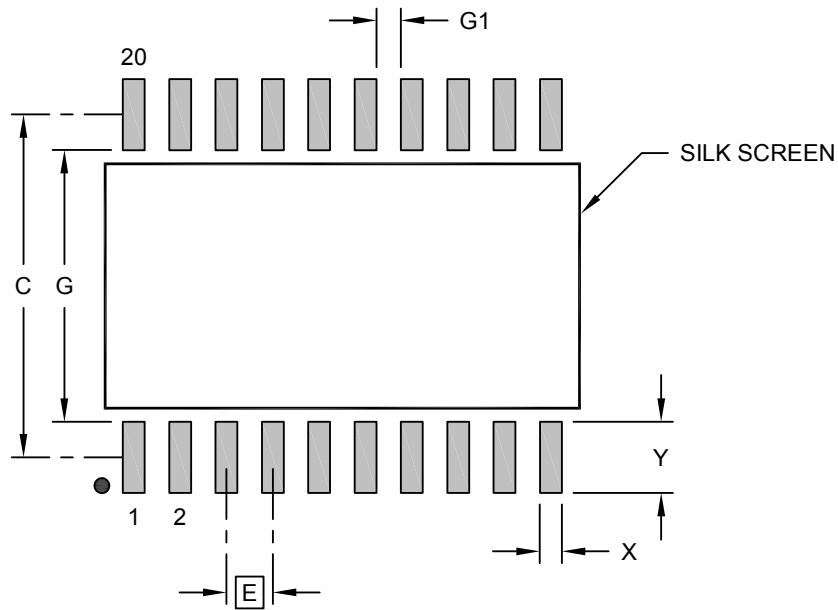

RECOMMENDED LAND PATTERN

		Units	MILLIMETERS		
		Dimension Limits	MIN	NOM	MAX
Contact Pitch	E		1.27 BSC		
Contact Pad Spacing	C			9.40	
Contact Pad Width (X20)	X				0.60
Contact Pad Length (X20)	Y				1.95
Contact Pad to Contact Pad	G	0.67			
Contact Pad to Contact Pad	G1	7.45			

Notes:

1. Dimensioning and tolerancing per ASME Y14.5M
BSC: Basic Dimension. Theoretically exact value shown without tolerances.
2. For best soldering results, thermal vias, if used, should be filled or tented to avoid solder loss during reflow process

Microchip Technology Drawing C04-2094 Rev D

36.6 20-Pin SSOP

20-Lead Plastic Shrink Small Outline (SS) – 5.30 mm Body [SSOP]

Note: For the most current package drawings, please see the Microchip Packaging Specification located at <http://www.microchip.com/packaging>

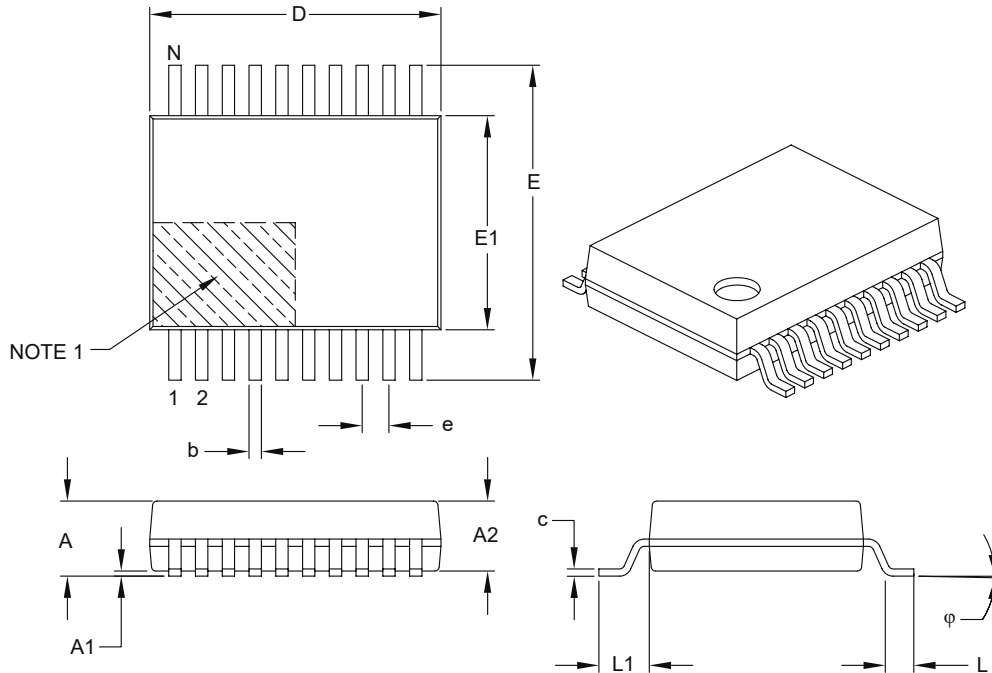

Dimension Limits	Units	MILLIMETERS		
		MIN	NOM	MAX
Number of Pins	N	20		
Pitch	e	0.65 BSC		
Overall Height	A	–	–	2.00
Molded Package Thickness	A2	1.65	1.75	1.85
Standoff	A1	0.05	–	–
Overall Width	E	7.40	7.80	8.20
Molded Package Width	E1	5.00	5.30	5.60
Overall Length	D	6.90	7.20	7.50
Foot Length	L	0.55	0.75	0.95
Footprint	L1	1.25 REF		
Lead Thickness	c	0.09	–	0.25
Foot Angle	φ	0°	4°	8°
Lead Width	b	0.22	–	0.38

Notes:

1. Pin 1 visual index feature may vary, but must be located within the hatched area.
2. Dimensions D and E1 do not include mold flash or protrusions. Mold flash or protrusions shall not exceed 0.20 mm per side.
3. Dimensioning and tolerancing per ASME Y14.5M.

BSC: Basic Dimension. Theoretically exact value shown without tolerances.

REF: Reference Dimension, usually without tolerance, for information purposes only.

Microchip Technology Drawing C04-072B

20-Lead Plastic Shrink Small Outline (SS) - 5.30 mm Body [SSOP]

Note: For the most current package drawings, please see the Microchip Packaging Specification located at <http://www.microchip.com/packaging>

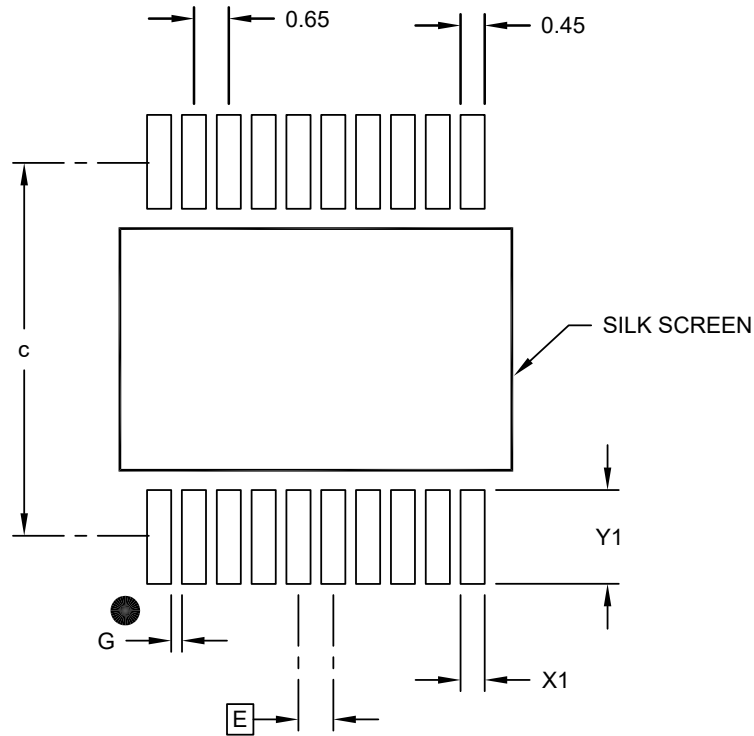

RECOMMENDED LAND PATTERN

Units		MILLIMETERS		
Dimension Limits		MIN	NOM	MAX
Contact Pitch	E	0.65 BSC		
Contact Pad Spacing	C		7.20	
Contact Pad Width (X20)	X1			0.45
Contact Pad Length (X20)	Y1			1.75
Distance Between Pads	G	0.20		

Notes:

1. Dimensioning and tolerancing per ASME Y14.5M
 BSC: Basic Dimension. Theoretically exact value shown without tolerances.

Microchip Technology Drawing No. C04-2072B

36.7 20-Pin VQFN

20-Lead Very Thin Plastic Quad Flat, No Lead Package (REB) - 3x3 mm Body [VQFN]
With 1.7 mm Exposed Pad; Atmel Legacy Global Package Code ZCL

Note: For the most current package drawings, please see the Microchip Packaging Specification located at <http://www.microchip.com/packaging>

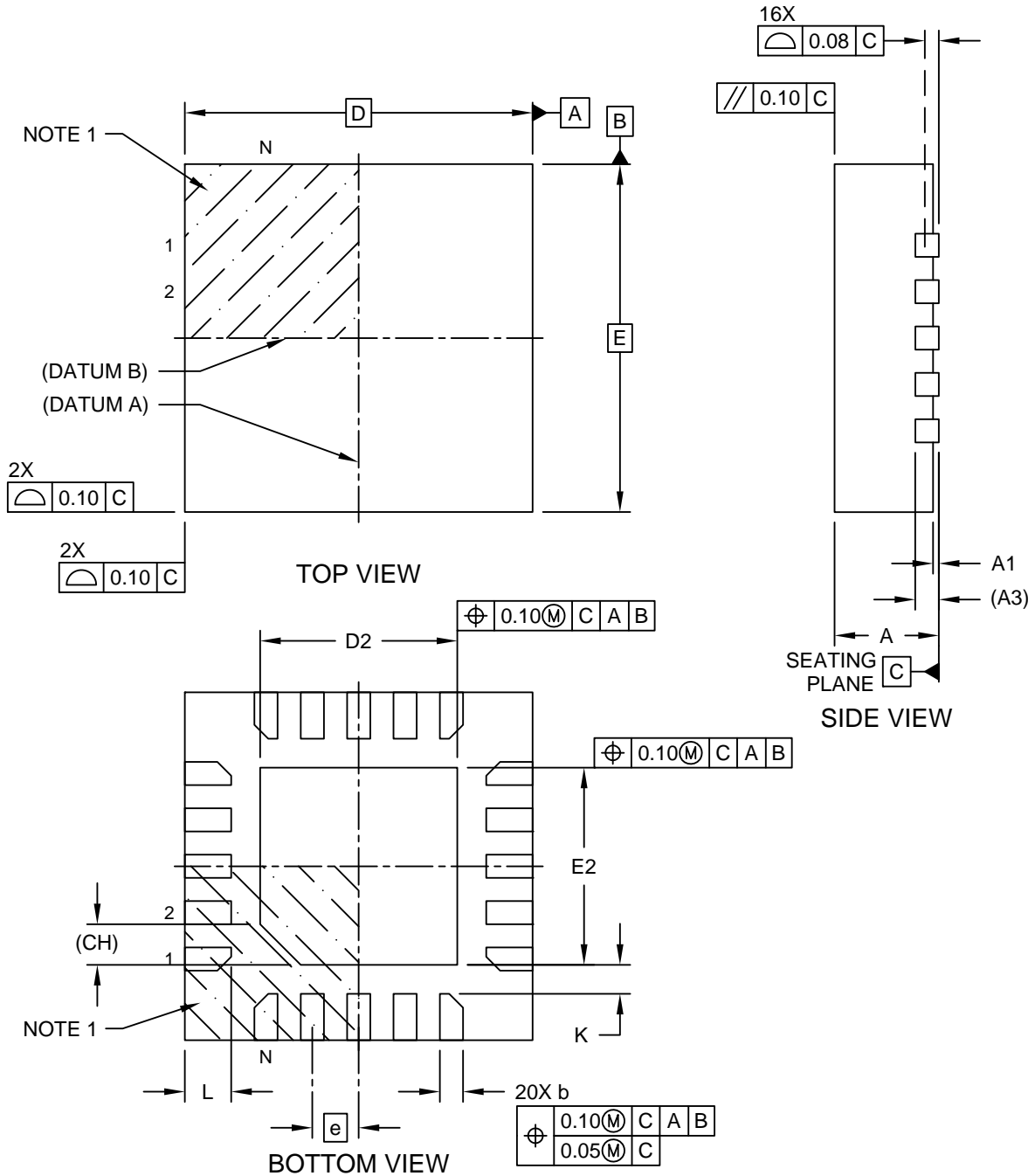

Microchip Technology Drawing C04-21380 Rev A Sheet 1 of 2

20-Lead Very Thin Plastic Quad Flat, No Lead Package (REB) - 3x3 mm Body [VQFN] With 1.7 mm Exposed Pad; Atmel Legacy Global Package Code ZCL

Note: For the most current package drawings, please see the Microchip Packaging Specification located at <http://www.microchip.com/packaging>

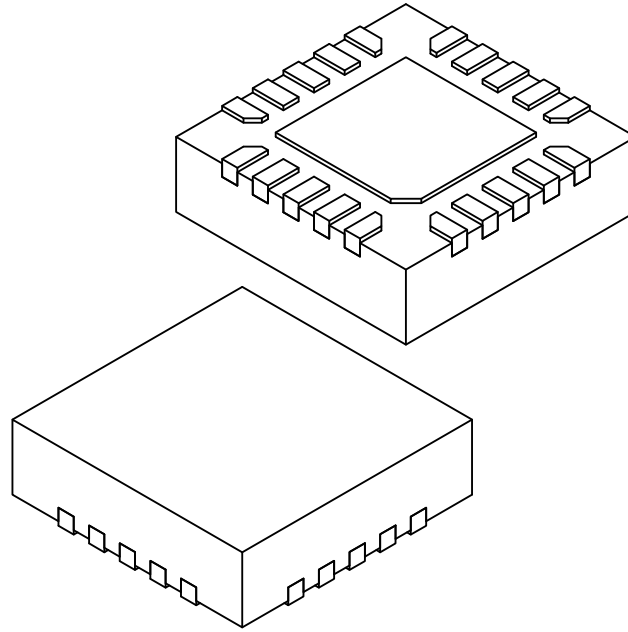

Dimension Limits	Units	MILLIMETERS		
		MIN	NOM	MAX
Number of Terminals	N	20		
Pitch	e	0.40 BSC		
Overall Height	A	0.80	0.85	0.90
Standoff	A1	0.00	0.035	0.05
Terminal Thickness	A3	0.203 REF		
Overall Length	D	3.00 BSC		
Exposed Pad Length	D2	1.60	1.70	1.80
Overall Width	E	3.00 BSC		
Exposed Pad Width	E2	1.60	1.70	1.80
Terminal Width	b	0.15	0.20	0.25
Terminal Length	L	0.35	0.40	0.45
Terminal-to-Exposed-Pad	K	0.20	-	-
Pin 1 Index Chamfer	CH	0.35 REF		

Notes:

- Pin 1 visual index feature may vary, but must be located within the hatched area.
- Package is saw singulated
- Dimensioning and tolerancing per ASME Y14.5M
 BSC: Basic Dimension. Theoretically exact value shown without tolerances.
 REF: Reference Dimension, usually without tolerance, for information purposes only.

Microchip Technology Drawing C04-21380 Rev A Sheet 2 of 2

20-Lead Very Thin Plastic Quad Flat, No Lead Package (REB) - 3x3 mm Body [VQFN] With 1.7 mm Exposed Pad; Atmel Legacy Global Package Code ZCL

Note: For the most current package drawings, please see the Microchip Packaging Specification located at <http://www.microchip.com/packaging>

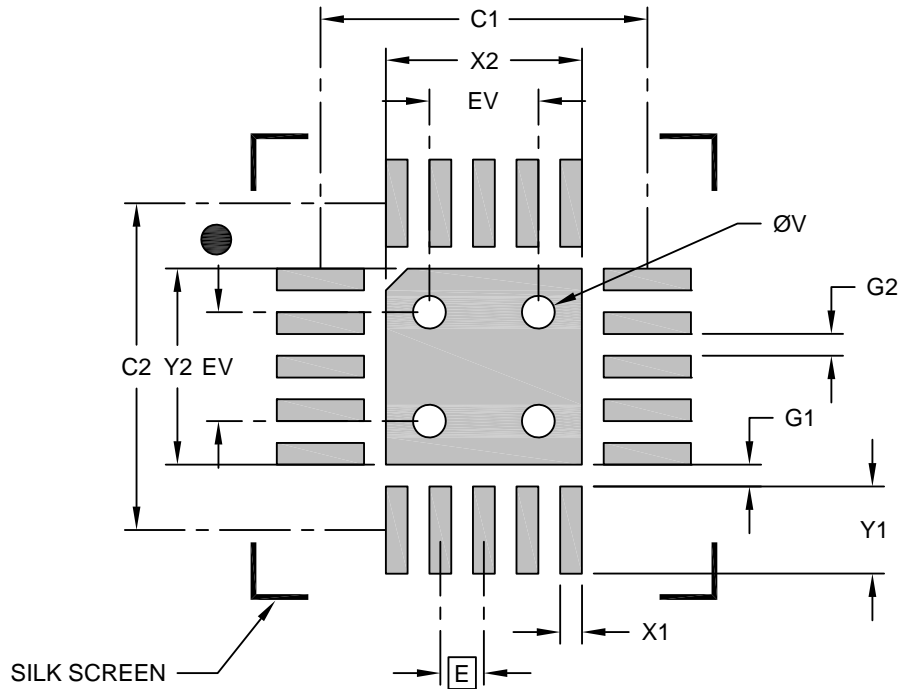

RECOMMENDED LAND PATTERN

Dimension Limits	Units	MILLIMETERS		
		MIN	NOM	MAX
Contact Pitch	E	0.40 BSC		
Optional Center Pad Width	X2			1.80
Optional Center Pad Length	Y2			1.80
Contact Pad Spacing	C1		3.00	
Contact Pad Spacing	C2		3.00	
Contact Pad Width (X20)	X1			0.20
Contact Pad Length (X20)	Y1			0.80
Contact Pad to Center Pad (X20)	G1	0.20		
Contact Pad to Contact Pad (X16)	G2	0.20		
Thermal Via Diameter	V		0.30	
Thermal Via Pitch	EV		1.00	

Notes:

1. Dimensioning and tolerancing per ASME Y14.5M
BSC: Basic Dimension. Theoretically exact value shown without tolerances.
2. For best soldering results, thermal vias, if used, should be filled or tented to avoid solder loss during reflow process

Microchip Technology Drawing C04-23380 Rev A

36.8 20-Pin VQFN Wettable Flanks

20-Lead Very Thin Plastic Quad Flat, No Lead Package (2LX) - 3x3 mm Body [VQFN]
With 1.7 mm Exposed Pad and Stepped Wettable Flanks

Note: For the most current package drawings, please see the Microchip Packaging Specification located at <http://www.microchip.com/packaging>

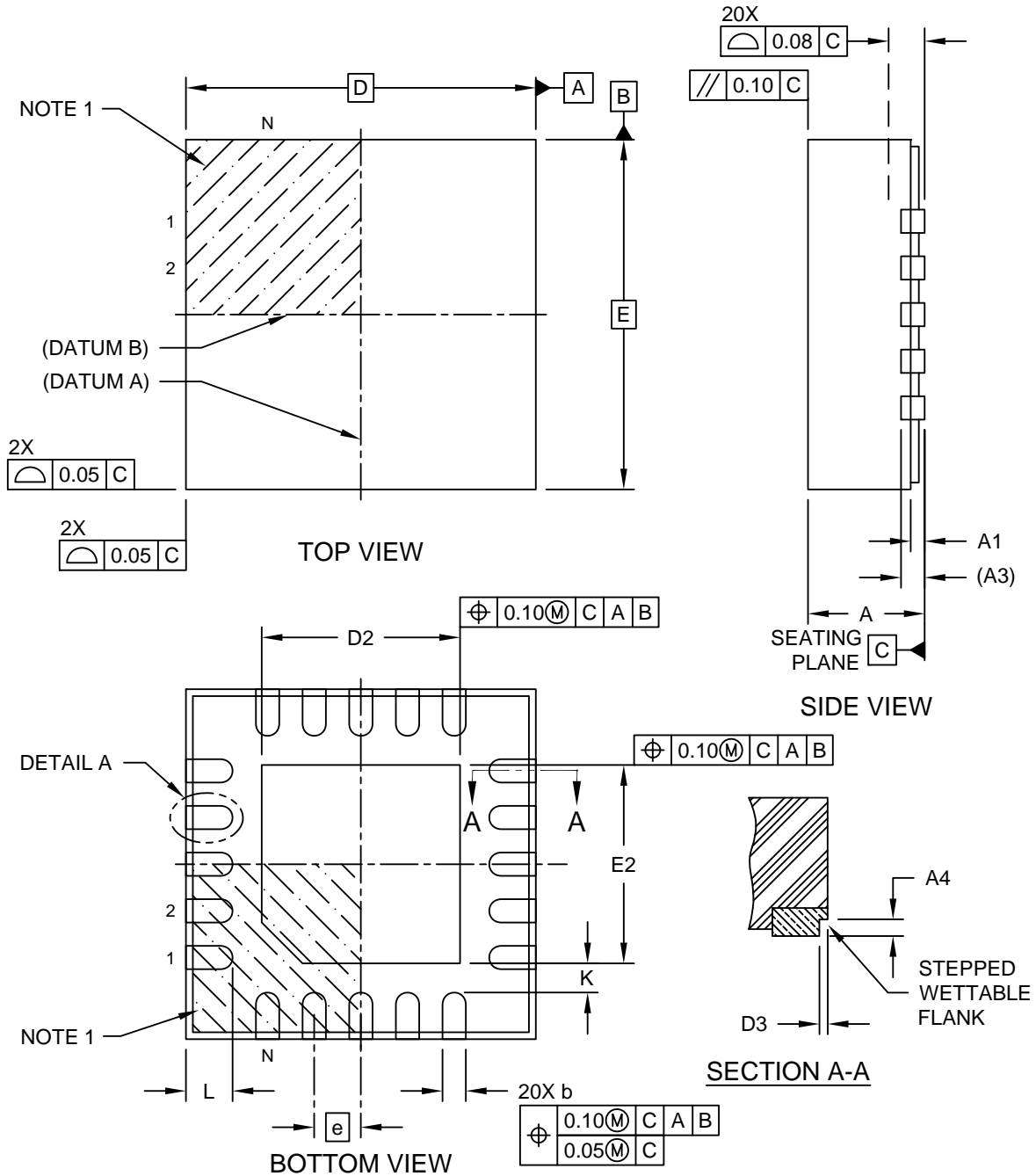

Microchip Technology Drawing C04-476-2LX Rev C Sheet 1 of 2

20-Lead Very Thin Plastic Quad Flat, No Lead Package (2LX) - 3x3 mm Body [VQFN] With 1.7 mm Exposed Pad and Stepped Wettable Flanks

Note: For the most current package drawings, please see the Microchip Packaging Specification located at <http://www.microchip.com/packaging>

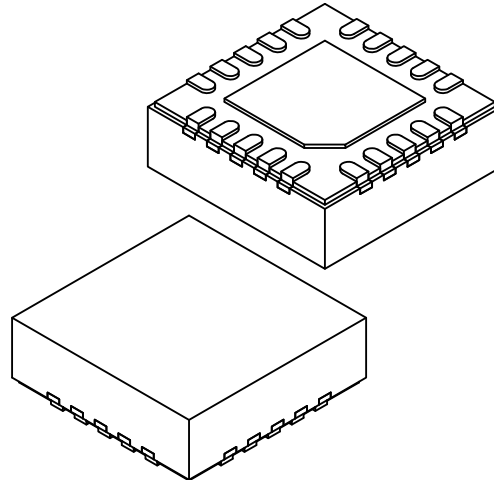
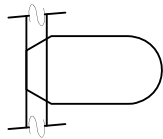
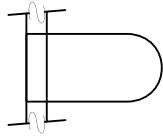

DETAIL 1
ALTERNATE TERMINAL
CONFIGURATIONS

Dimension Limits	Units	MILLIMETERS		
		MIN	NOM	MAX
Number of Terminals	N	20		
Pitch	e	0.40 BSC		
Overall Height	A	0.80	0.90	1.00
Standoff	A1	0.00	0.02	0.05
Terminal Thickness	A3	0.203 REF		
Overall Length	D	3.00 BSC		
Exposed Pad Length	D2	1.60	1.70	1.80
Overall Width	E	3.00 BSC		
Exposed Pad Width	E2	1.60	1.70	1.80
Terminal Width	b	0.15	0.20	0.25
Terminal Length	L	0.35	0.40	0.45
Terminal-to-Exposed-Pad	K	0.20	-	-
Wettable Flank Step Length	D3	-	-	0.085
Wettable Flank Step Height	A4	0.10	-	0.19

Dimensions D3 and A4 above apply to all new products released after November 1, and all products shipped after January 1, 2019, and supersede dimensions D3 and A4 below.

No physical changes are being made to any package; this update is to align cosmetic and tolerance variations from existing suppliers.

Wettable Flank Step Length	D3	0.035	0.06	0.085
Wettable Flank Step Height	A4	0.10	-	0.19

Notes:

- Pin 1 visual index feature may vary, but must be located within the hatched area.
- Package is saw singulated
- Dimensioning and tolerancing per ASME Y14.5M
BSC: Basic Dimension. Theoretically exact value shown without tolerances.
REF: Reference Dimension, usually without tolerance, for information purposes only.

Microchip Technology Drawing C04-476-2LX Rev C Sheet 2 of 2

20-Lead Very Thin Plastic Quad Flat, No Lead Package (2LX) - 3x3 mm Body [VQFN] With 1.7 mm Exposed Pad and Stepped Wettable Flanks

Note: For the most current package drawings, please see the Microchip Packaging Specification located at <http://www.microchip.com/packaging>

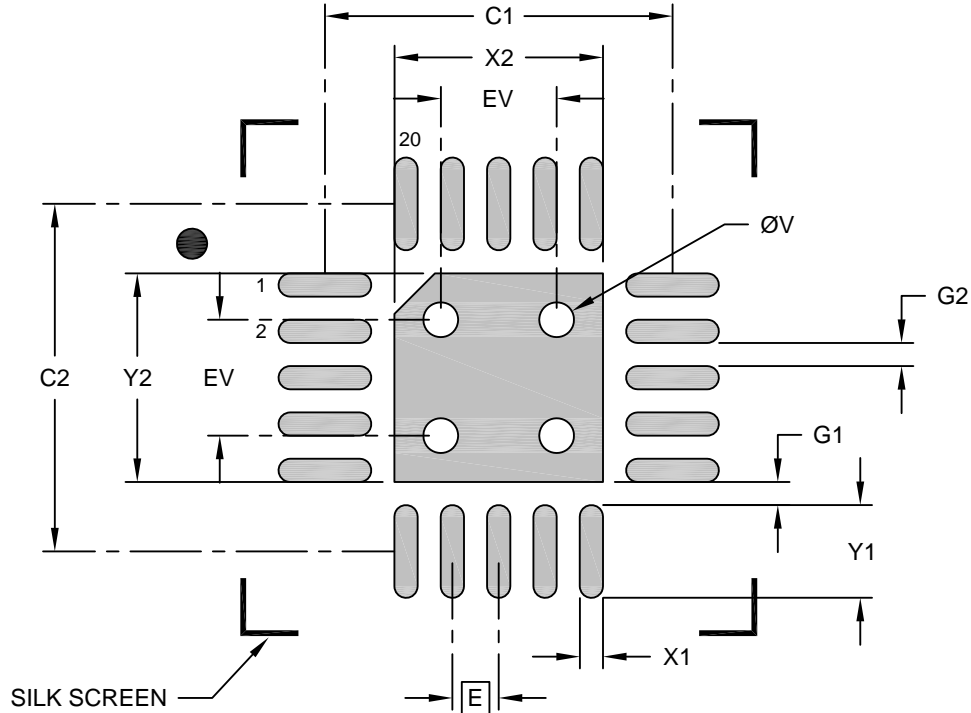

RECOMMENDED LAND PATTERN

	Units	MILLIMETERS		
		Dimension Limits		
		MIN	NOM	MAX
Contact Pitch	E	0.40 BSC		
Optional Center Pad Width	X2			1.80
Optional Center Pad Length	Y2			1.80
Contact Pad Spacing	C1		3.00	
Contact Pad Spacing	C2		3.00	
Contact Pad Width (X20)	X1			0.20
Contact Pad Length (X20)	Y1			0.80
Contact Pad to Center Pad (X20)	G1	0.20		
Contact Pad to Contact Pad (X16)	G2	0.20		
Thermal Via Diameter	V		0.30	
Thermal Via Pitch	EV		1.00	

Notes:

1. Dimensioning and tolerancing per ASME Y14.5M
BSC: Basic Dimension. Theoretically exact value shown without tolerances.
2. For best soldering results, thermal vias, if used, should be filled or tented to avoid solder loss during reflow process

Microchip Technology Drawing C04-2476-2LX Rev C

36.9 24-Pin VQFN

24-Lead Very Thin Plastic Quad Flat, No Lead Package (RLB) - 4x4 mm Body [VQFN]
Atmel Legacy Global Package Code ZHA

Note: For the most current package drawings, please see the Microchip Packaging Specification located at <http://www.microchip.com/packaging>

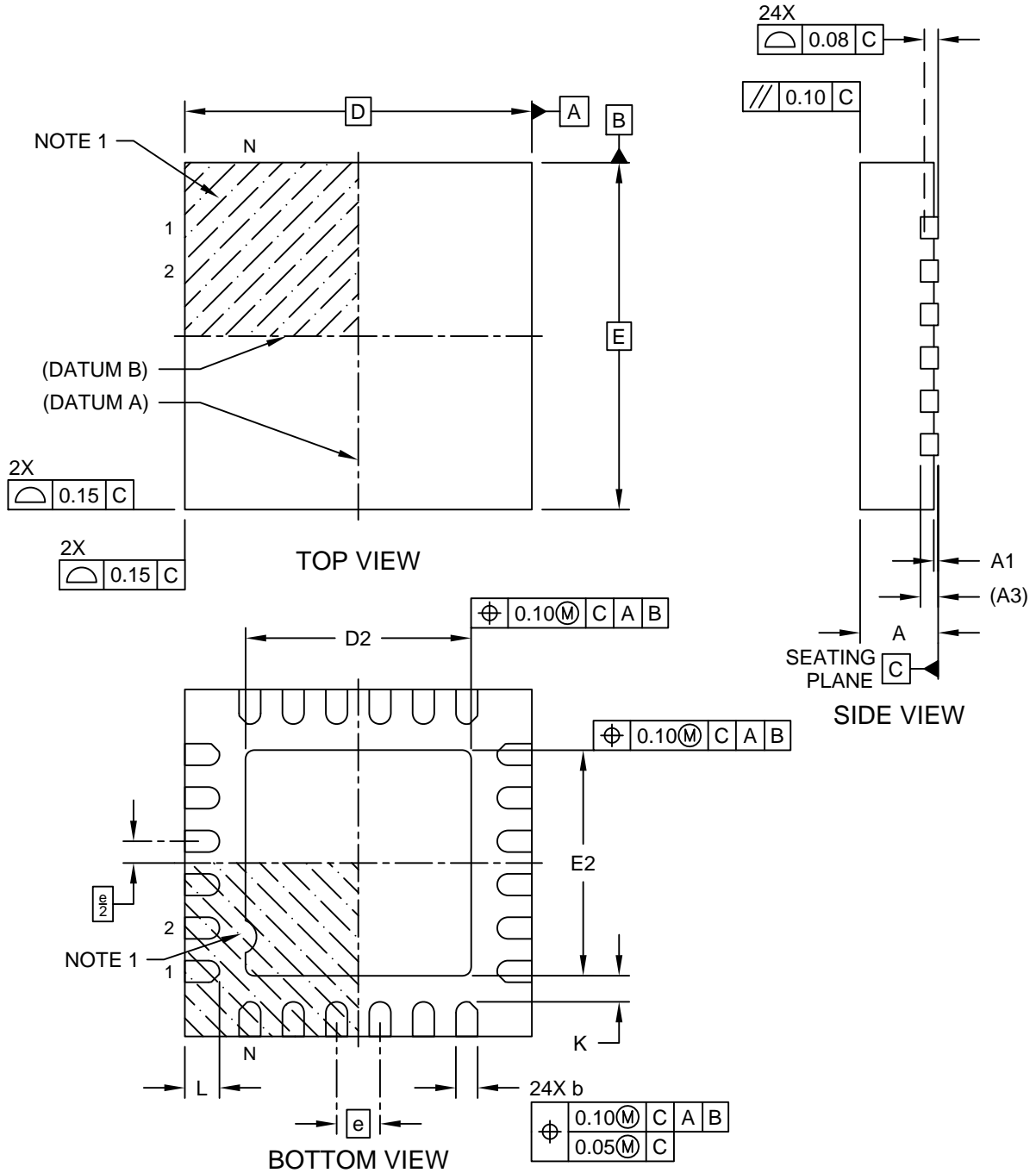

Microchip Technology Drawing C04-21386 Rev A Sheet 1 of 2

24-Lead Very Thin Plastic Quad Flat, No Lead Package (RLB) - 4x4 mm Body [VQFN] Atmel Legacy Global Package Code ZHA

Note: For the most current package drawings, please see the Microchip Packaging Specification located at <http://www.microchip.com/packaging>

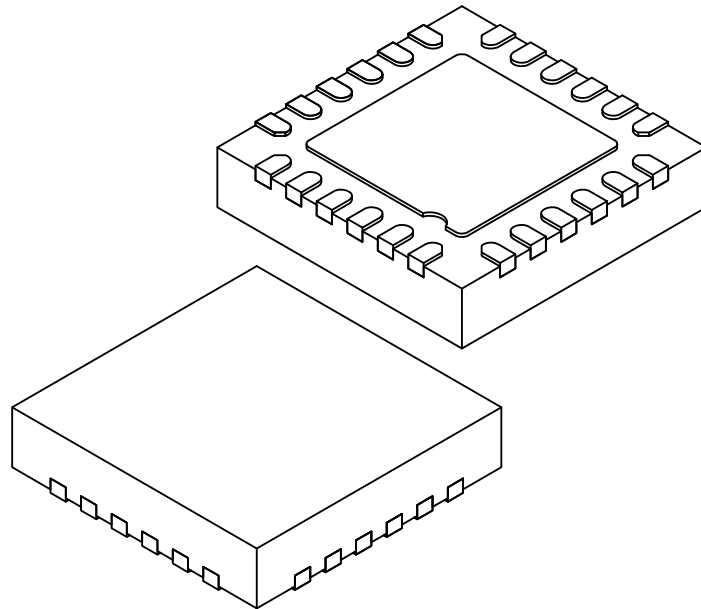

Dimension Limits	Units	MILLIMETERS		
		MIN	NOM	MAX
Number of Terminals	N	24		
Pitch	e	0.50 BSC		
Overall Height	A	0.80	0.85	0.90
Standoff	A1	0.00	-	0.05
Terminal Thickness	A3	0.203 REF		
Overall Length	D	4.00 BSC		
Exposed Pad Length	D2	2.45	2.60	2.75
Overall Width	E	4.00 BSC		
Exposed Pad Width	E2	2.45	2.60	2.75
Terminal Width	b	0.18	0.25	0.30
Terminal Length	L	0.35	0.40	0.45
Terminal-to-Exposed-Pad	K	0.20	-	-

Notes:

1. Pin 1 visual index feature may vary, but must be located within the hatched area.
2. Package is saw singulated
3. Dimensioning and tolerancing per ASME Y14.5M
 BSC: Basic Dimension. Theoretically exact value shown without tolerances.
 REF: Reference Dimension, usually without tolerance, for information purposes only.

Microchip Technology Drawing C04-21386 Rev A Sheet 2 of 2

© 2019 Microchip Technology Inc.

24-Lead Very Thin Plastic Quad Flat, No Lead Package (RLB) - 4x4 mm Body [VQFN] Atmel Legacy Global Package Code ZHA

Note: For the most current package drawings, please see the Microchip Packaging Specification located at <http://www.microchip.com/packaging>

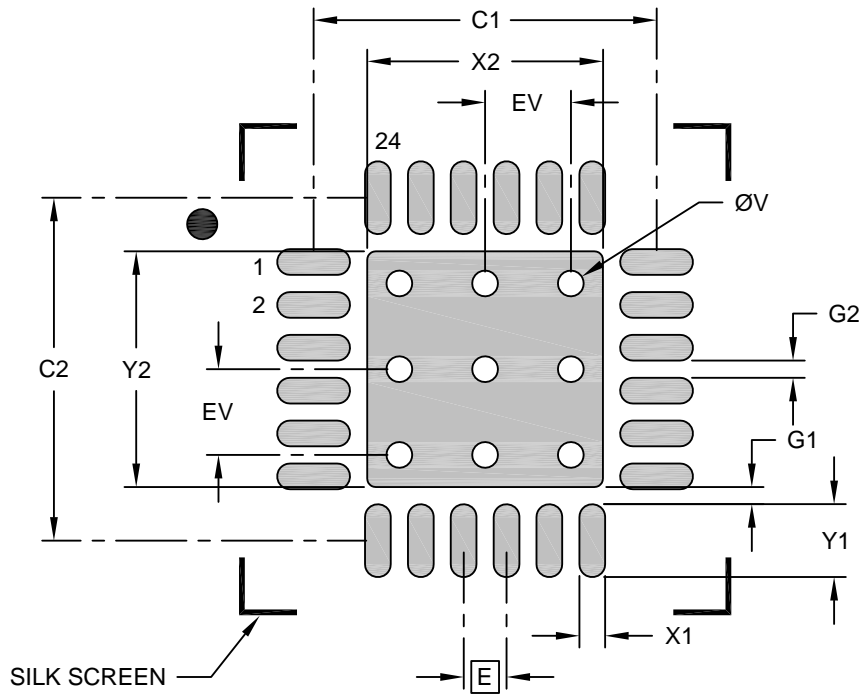

RECOMMENDED LAND PATTERN

Dimension Limits		MILLIMETERS		
		MIN	NOM	MAX
Contact Pitch	E	0.50 BSC		
Optional Center Pad Width	X2			2.75
Optional Center Pad Length	Y2			2.75
Contact Pad Spacing	C1		4.00	
Contact Pad Spacing	C2		4.00	
Contact Pad Width (X24)	X1			0.30
Contact Pad Length (X24)	Y1			0.85
Contact Pad to Center Pad (X24)	G1	0.20		
Contact Pad to Contact Pad (X20)	G2	0.20		
Thermal Via Diameter	V		0.30	
Thermal Via Pitch	EV		1.00	

Notes:

1. Dimensioning and tolerancing per ASME Y14.5M
BSC: Basic Dimension. Theoretically exact value shown without tolerances.
2. For best soldering results, thermal vias, if used, should be filled or tented to avoid solder loss during reflow process

Microchip Technology Drawing C04-23386 Rev A

© 2019 Microchip Technology Inc.

36.10 24-Pin VQFN Wettable Flanks

24-Lead Very Thin Plastic Quad Flat, No Lead Package (U3B) - 4x4 mm Body [VQFN] With 2.6mm Exposed Pad and Stepped Wettable Flanks; Atmel Legacy ZCY

Note: For the most current package drawings, please see the Microchip Packaging Specification located at <http://www.microchip.com/packaging>

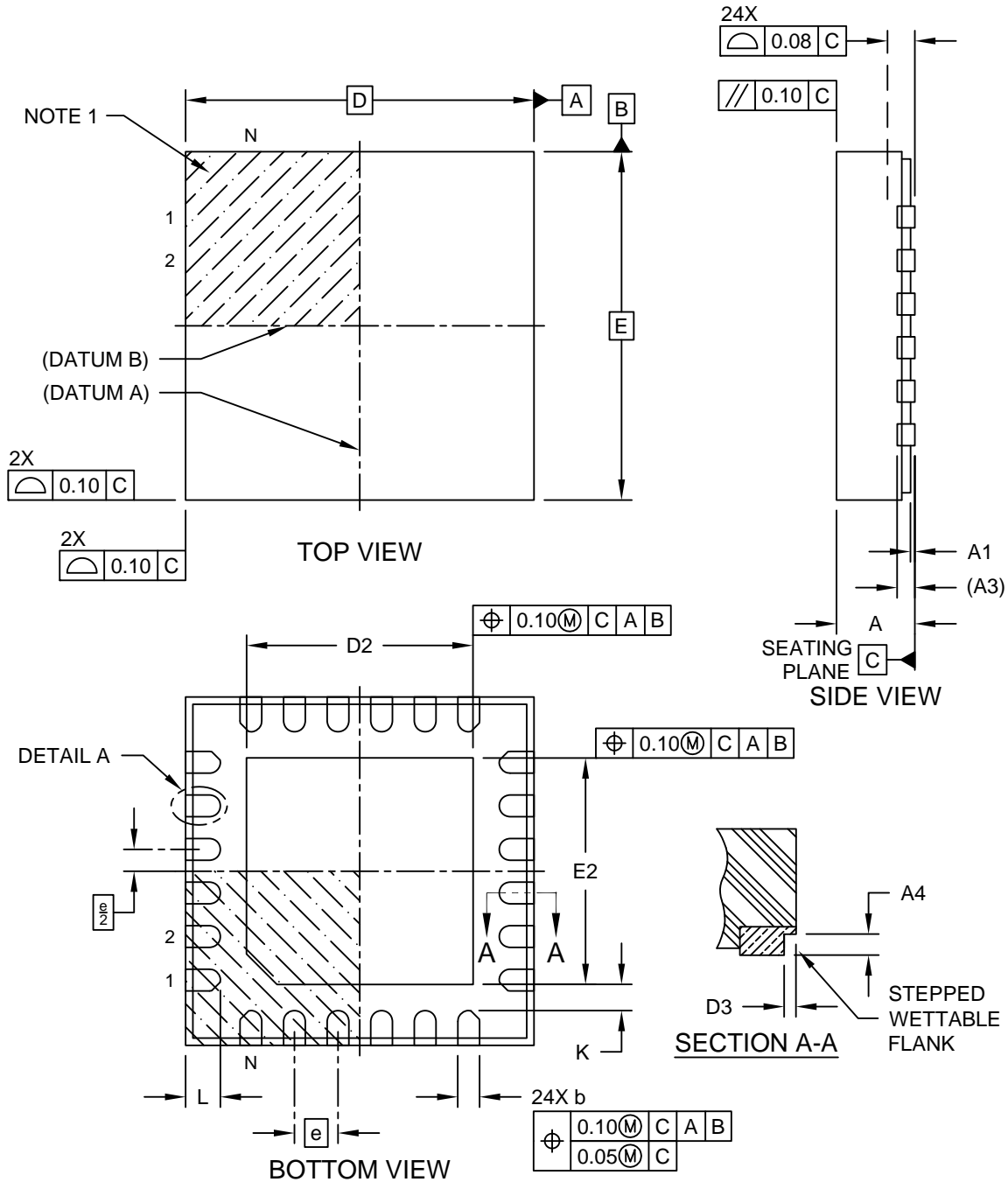

Microchip Technology Drawing C04-21483 Rev A Sheet 1 of 2

24-Lead Very Thin Plastic Quad Flat, No Lead Package (U3B) - 4x4 mm Body [VQFN] With 2.6mm Exposed Pad and Stepped Wettable Flanks; Atmel Legacy ZCY

Note: For the most current package drawings, please see the Microchip Packaging Specification located at <http://www.microchip.com/packaging>

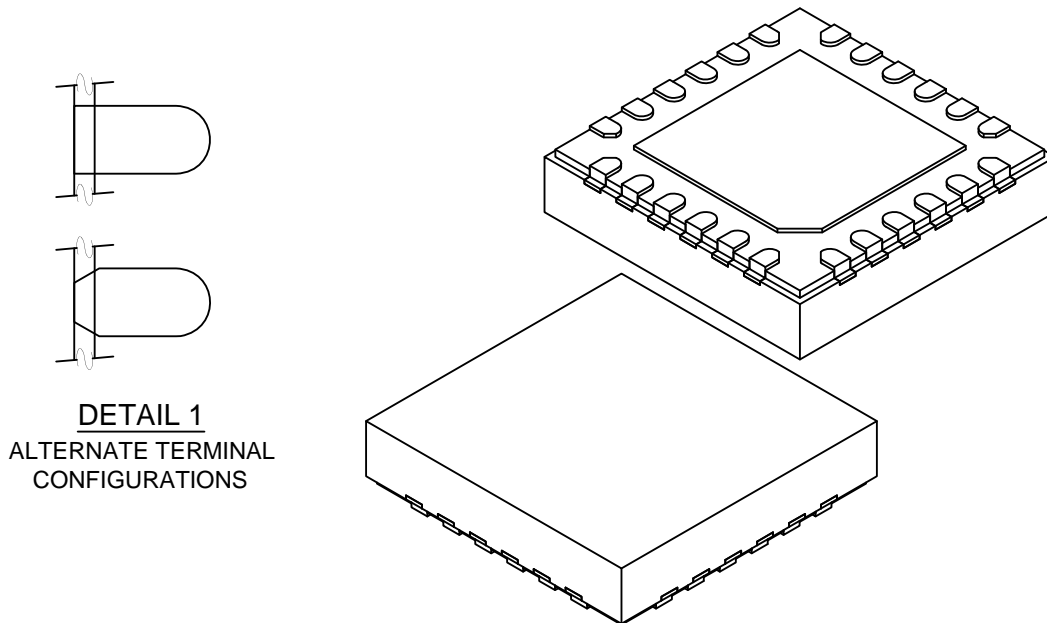

DETAIL 1
ALTERNATE TERMINAL
CONFIGURATIONS

Dimension Limits	Units	MILLIMETERS		
		MIN	NOM	MAX
Number of Terminals	N	24		
Pitch	e	0.50 BSC		
Overall Height	A	0.80	0.85	0.90
Standoff	A1	0.00	0.035	0.05
Terminal Thickness	A3	0.203 REF		
Overall Length	D	4.00 BSC		
Exposed Pad Length	D2	2.50	2.60	2.70
Overall Width	E	4.00 BSC		
Exposed Pad Width	E2	2.50	2.60	2.70
Terminal Width	b	0.20	0.25	0.30
Terminal Length	L	0.35	0.40	0.45
Terminal-to-Exposed-Pad	K	0.20	-	-
Wettable Flank Step Length	D3	-	-	0.085
Wettable Flank Step Height	A4	0.10	-	0.19

Notes:

- Pin 1 visual index feature may vary, but must be located within the hatched area.
- Package is saw singulated
- Dimensioning and tolerancing per ASME Y14.5M
BSC: Basic Dimension. Theoretically exact value shown without tolerances.
REF: Reference Dimension, usually without tolerance, for information purposes only.

Microchip Technology Drawing C04-21483 Rev A Sheet 2 of 2

24-Lead Very Thin Plastic Quad Flat, No Lead Package (U3B) - 4x4 mm Body [VQFN] With 2.6mm Exposed Pad and Stepped Wettable Flanks; Atmel Legacy ZCY

Note: For the most current package drawings, please see the Microchip Packaging Specification located at <http://www.microchip.com/packaging>

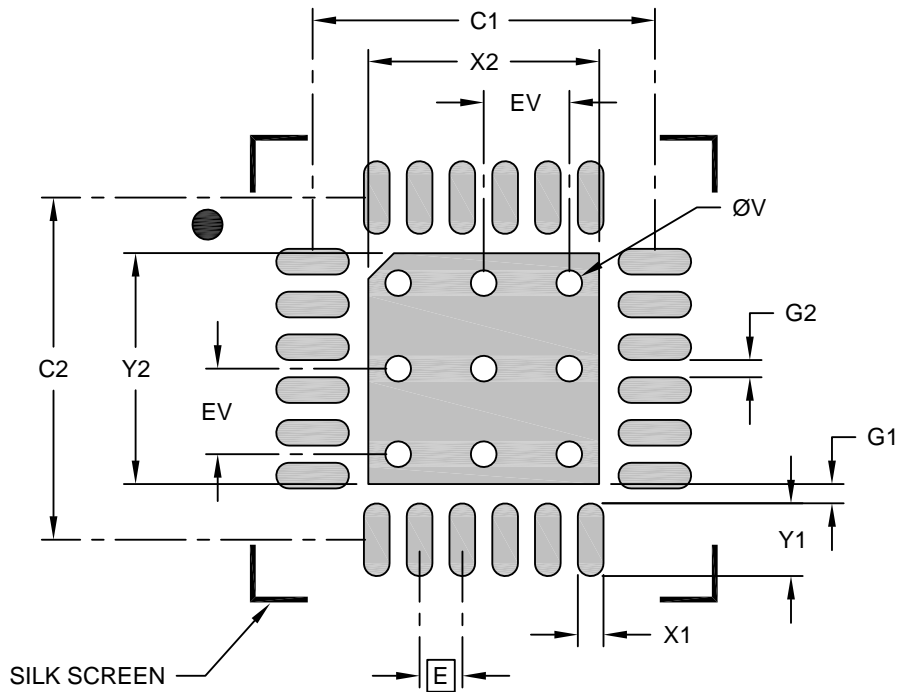

RECOMMENDED LAND PATTERN

Units		MILLIMETERS		
		MIN	NOM	MAX
Dimension	Limits			
Contact Pitch	E	0.50 BSC		
Optional Center Pad Width	X2			2.70
Optional Center Pad Length	Y2			2.70
Contact Pad Spacing	C1		4.00	
Contact Pad Spacing	C2		4.00	
Contact Pad Width (X24)	X1			0.30
Contact Pad Length (X24)	Y1			0.85
Contact Pad to Center Pad (X24)	G1	0.23		
Contact Pad to Contact Pad (20)	G2	0.20		
Thermal Via Diameter	V		0.30	
Thermal Via Pitch	EV		1.00	

Notes:

1. Dimensioning and tolerancing per ASME Y14.5M
BSC: Basic Dimension. Theoretically exact value shown without tolerances.
2. For best soldering results, thermal vias, if used, should be filled or tented to avoid solder loss during reflow process

Microchip Technology Drawing C04-23483 Rev A Sheet 1 of 2

37. Data Sheet Revision History

Note: The data sheet revision is independent of the die revision and the device variant (last letter of the ordering number).

37.1 Rev.B - 12/2021

Section	Changes
Document	<ul style="list-style-type: none"> • Package top markings added • Editorial updates throughout the document
PORT	Slew Rate Limit Enable (SLR) bit in the Port Control (PORTCTRL) register added
ADC	PGA initialization time is 20 μ s
USART	Description of IrDA Event Input Enable (IREI) bit in Event Control (EVCTRL) corrected
INTCTRL	Added information: When configuring the entire Flash as BOOT section, the IVSEL bit in the CTRLA register is ignored.
TWI	CTRLA.SDASETUP is used in client mode to select the clock hold time to ensure minimum setup time
Electrical Characteristics	<ul style="list-style-type: none"> • Table 33-5: Typical values altered and min./max. values added • Table 33-6: Completed • Table 33-7: ADC updated • Table 33-12: Note added • Table 33-13: Note added • Table 33-22: Symbol column updated • Table 33-23: Value set reduced and updated • ADC Table 33-26: values updated • ADC Table 33-27: Values updated • ADC Table 33-28: Values updated • TEMPSENSE Table 33-29: Accuracy value updated • 33.18. AC: Typical values altered and min./max. values added in all tables

37.2 Rev.A - 09/2021

Section	Changes
Document	Initial document release

The Microchip Website

Microchip provides online support via our website at www.microchip.com/. This website is used to make files and information easily available to customers. Some of the content available includes:

- **Product Support** – Data sheets and errata, application notes and sample programs, design resources, user's guides and hardware support documents, latest software releases and archived software
- **General Technical Support** – Frequently Asked Questions (FAQs), technical support requests, online discussion groups, Microchip design partner program member listing
- **Business of Microchip** – Product selector and ordering guides, latest Microchip press releases, listing of seminars and events, listings of Microchip sales offices, distributors and factory representatives

Product Change Notification Service

Microchip's product change notification service helps keep customers current on Microchip products. Subscribers will receive email notification whenever there are changes, updates, revisions or errata related to a specified product family or development tool of interest.

To register, go to www.microchip.com/pcn and follow the registration instructions.

Customer Support

Users of Microchip products can receive assistance through several channels:

- Distributor or Representative
- Local Sales Office
- Embedded Solutions Engineer (ESE)
- Technical Support

Customers should contact their distributor, representative or ESE for support. Local sales offices are also available to help customers. A listing of sales offices and locations is included in this document.

Technical support is available through the website at: www.microchip.com/support

Product Identification System

To order or obtain information, e.g., on pricing or delivery, refer to the factory or the listed sales office.

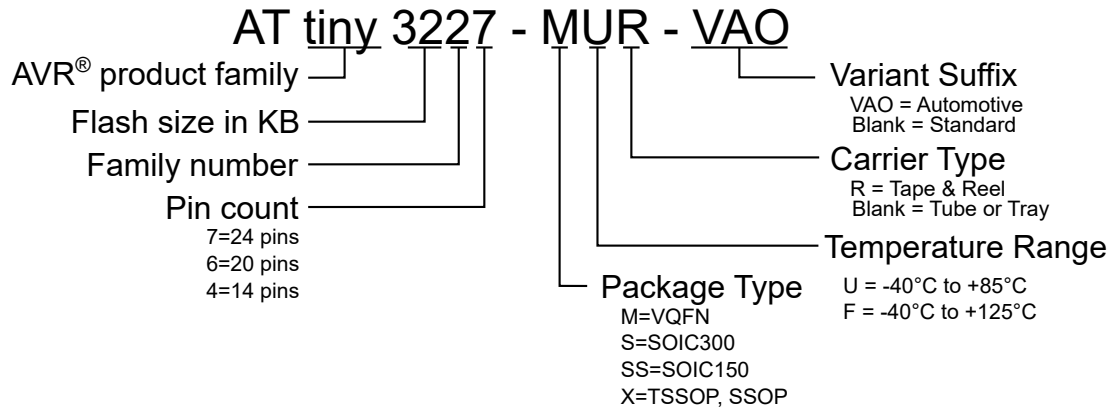

Note: The Tape & Reel identifier only appears in the catalog part number description. Use this identifier for ordering purposes. Check with your Microchip Sales Office for package availability with the Tape and Reel option.

Note: The VAO variants have been designed, manufactured, tested, and qualified per AEC-Q100 requirements for automotive applications. These products may use a different package than non-VAO parts and have additional specifications in their Electrical Characteristics.

Microchip Devices Code Protection Feature

Note the following details of the code protection feature on Microchip products:

- Microchip products meet the specifications contained in their particular Microchip Data Sheet.
- Microchip believes that its family of products is secure when used in the intended manner, within operating specifications, and under normal conditions.
- Microchip values and aggressively protects its intellectual property rights. Attempts to breach the code protection features of Microchip product is strictly prohibited and may violate the Digital Millennium Copyright Act.
- Neither Microchip nor any other semiconductor manufacturer can guarantee the security of its code. Code protection does not mean that we are guaranteeing the product is “unbreakable”. Code protection is constantly evolving. Microchip is committed to continuously improving the code protection features of our products.

Legal Notice

This publication and the information herein may be used only with Microchip products, including to design, test, and integrate Microchip products with your application. Use of this information in any other manner violates these terms. Information regarding device applications is provided only for your convenience and may be superseded by updates. It is your responsibility to ensure that your application meets with your specifications. Contact your local Microchip sales office for additional support or, obtain additional support at www.microchip.com/en-us/support/design-help/client-support-services.

THIS INFORMATION IS PROVIDED BY MICROCHIP "AS IS". MICROCHIP MAKES NO REPRESENTATIONS OR WARRANTIES OF ANY KIND WHETHER EXPRESS OR IMPLIED, WRITTEN OR ORAL, STATUTORY OR OTHERWISE, RELATED TO THE INFORMATION INCLUDING BUT NOT LIMITED TO ANY IMPLIED WARRANTIES OF NON-INFRINGEMENT, MERCHANTABILITY, AND FITNESS FOR A PARTICULAR PURPOSE, OR WARRANTIES RELATED TO ITS CONDITION, QUALITY, OR PERFORMANCE.

IN NO EVENT WILL MICROCHIP BE LIABLE FOR ANY INDIRECT, SPECIAL, PUNITIVE, INCIDENTAL, OR CONSEQUENTIAL LOSS, DAMAGE, COST, OR EXPENSE OF ANY KIND WHATSOEVER RELATED TO THE INFORMATION OR ITS USE, HOWEVER CAUSED, EVEN IF MICROCHIP HAS BEEN ADVISED OF THE POSSIBILITY OR THE DAMAGES ARE FORESEEABLE. TO THE FULLEST EXTENT ALLOWED BY LAW,

MICROCHIP'S TOTAL LIABILITY ON ALL CLAIMS IN ANY WAY RELATED TO THE INFORMATION OR ITS USE WILL NOT EXCEED THE AMOUNT OF FEES, IF ANY, THAT YOU HAVE PAID DIRECTLY TO MICROCHIP FOR THE INFORMATION.

Use of Microchip devices in life support and/or safety applications is entirely at the buyer's risk, and the buyer agrees to defend, indemnify and hold harmless Microchip from any and all damages, claims, suits, or expenses resulting from such use. No licenses are conveyed, implicitly or otherwise, under any Microchip intellectual property rights unless otherwise stated.

Trademarks

The Microchip name and logo, the Microchip logo, Adaptec, AnyRate, AVR, AVR logo, AVR Freaks, BesTime, BitCloud, CryptoMemory, CryptoRF, dsPIC, flexPWR, HELDO, IGLOO, JukeBlox, KeeLoq, Kleer, LANCheck, LinkMD, maXStylus, maXTouch, MediaLB, megaAVR, Microsemi, Microsemi logo, MOST, MOST logo, MPLAB, OptoLyzer, PIC, picoPower, PICSTART, PIC32 logo, PolarFire, Prochip Designer, QTouch, SAM-BA, SenGenuity, SpyNIC, SST, SST Logo, SuperFlash, Symmetricom, SyncServer, Tachyon, TimeSource, tinyAVR, UNI/O, Vectron, and XMEGA are registered trademarks of Microchip Technology Incorporated in the U.S.A. and other countries.

AgileSwitch, APT, ClockWorks, The Embedded Control Solutions Company, EtherSynch, Flashtec, Hyper Speed Control, HyperLight Load, IntelliMOS, Libero, motorBench, mTouch, Powermite 3, Precision Edge, ProASIC, ProASIC Plus, ProASIC Plus logo, Quiet- Wire, SmartFusion, SyncWorld, Temux, TimeCesium, TimeHub, TimePictra, TimeProvider, TrueTime, WinPath, and ZL are registered trademarks of Microchip Technology Incorporated in the U.S.A.

Adjacent Key Suppression, AKS, Analog-for-the-Digital Age, Any Capacitor, AnyIn, AnyOut, Augmented Switching, BlueSky, BodyCom, CodeGuard, CryptoAuthentication, CryptoAutomotive, CryptoCompanion, CryptoController, dsPICDEM, dsPICDEM.net, Dynamic Average Matching, DAM, ECAN, Espresso T1S, EtherGREEN, GridTime, IdealBridge, In-Circuit Serial Programming, ICSP, INICnet, Intelligent Paralleling, Inter-Chip Connectivity, JitterBlocker, Knob-on-Display, maxCrypto, maxView, memBrain, Mindi, MiWi, MPASM, MPF, MPLAB Certified logo, MPLIB, MPLINK, MultiTRAK, NetDetach, NVM Express, NVMe, Omniscient Code Generation, PICDEM, PICDEM.net, PICkit, PICtail, PowerSmart, PureSilicon, QMatrix, REAL ICE, Ripple Blocker, RTAX, RTG4, SAM-ICE, Serial Quad I/O, simpleMAP, SimpliPHY, SmartBuffer, SmartHLS, SMART-I.S., storClad, SQL, SuperSwitcher, SuperSwitcher II, Switchtec, SynchroPHY, Total Endurance, TSHARC, USBCheck, VariSense, VectorBlox, VeriPHY, ViewSpan, WiperLock, XpressConnect, and ZENA are trademarks of Microchip Technology Incorporated in the U.S.A. and other countries.

SQTP is a service mark of Microchip Technology Incorporated in the U.S.A.

The Adaptec logo, Frequency on Demand, Silicon Storage Technology, Symmcom, and Trusted Time are registered trademarks of Microchip Technology Inc. in other countries.

GestIC is a registered trademark of Microchip Technology Germany II GmbH & Co. KG, a subsidiary of Microchip Technology Inc., in other countries.

All other trademarks mentioned herein are property of their respective companies.

© 2021, Microchip Technology Incorporated and its subsidiaries. All Rights Reserved.

ISBN: 978-1-5224-9469-0

Quality Management System

For information regarding Microchip's Quality Management Systems, please visit www.microchip.com/quality.

Worldwide Sales and Service

AMERICAS	ASIA/PACIFIC	ASIA/PACIFIC	EUROPE
<p>Corporate Office 2355 West Chandler Blvd. Chandler, AZ 85224-6199 Tel: 480-792-7200 Tel: 480-792-7277 Technical Support: www.microchip.com/support Web Address: www.microchip.com</p> <p>Atlanta Duluth, GA Tel: 678-957-9614 Fax: 678-957-1455</p> <p>Austin, TX Tel: 512-257-3370</p> <p>Boston Westborough, MA Tel: 774-760-0087 Fax: 774-760-0088</p> <p>Chicago Itasca, IL Tel: 630-285-0071 Fax: 630-285-0075</p> <p>Dallas Addison, TX Tel: 972-818-7423 Fax: 972-818-2924</p> <p>Detroit Novi, MI Tel: 248-848-4000</p> <p>Houston, TX Tel: 281-894-5983</p> <p>Indianapolis Noblesville, IN Tel: 317-773-8323 Fax: 317-773-5453 Tel: 317-536-2380</p> <p>Los Angeles Mission Viejo, CA Tel: 949-462-9523 Fax: 949-462-9608 Tel: 951-273-7800</p> <p>Raleigh, NC Tel: 919-844-7510</p> <p>New York, NY Tel: 631-435-6000</p> <p>San Jose, CA Tel: 408-735-9110 Tel: 408-436-4270</p> <p>Canada - Toronto Tel: 905-695-1980 Fax: 905-695-2078</p>	<p>Australia - Sydney Tel: 61-2-9868-6733</p> <p>China - Beijing Tel: 86-10-8569-7000</p> <p>China - Chengdu Tel: 86-28-8665-5511</p> <p>China - Chongqing Tel: 86-23-8980-9588</p> <p>China - Dongguan Tel: 86-769-8702-9880</p> <p>China - Guangzhou Tel: 86-20-8755-8029</p> <p>China - Hangzhou Tel: 86-571-8792-8115</p> <p>China - Hong Kong SAR Tel: 852-2943-5100</p> <p>China - Nanjing Tel: 86-25-8473-2460</p> <p>China - Qingdao Tel: 86-532-8502-7355</p> <p>China - Shanghai Tel: 86-21-3326-8000</p> <p>China - Shenyang Tel: 86-24-2334-2829</p> <p>China - Shenzhen Tel: 86-755-8864-2200</p> <p>China - Suzhou Tel: 86-186-6233-1526</p> <p>China - Wuhan Tel: 86-27-5980-5300</p> <p>China - Xian Tel: 86-29-8833-7252</p> <p>China - Xiamen Tel: 86-592-2388138</p> <p>China - Zhuhai Tel: 86-756-3210040</p>	<p>India - Bangalore Tel: 91-80-3090-4444</p> <p>India - New Delhi Tel: 91-11-4160-8631</p> <p>India - Pune Tel: 91-20-4121-0141</p> <p>Japan - Osaka Tel: 81-6-6152-7160</p> <p>Japan - Tokyo Tel: 81-3-6880-3770</p> <p>Korea - Daegu Tel: 82-53-744-4301</p> <p>Korea - Seoul Tel: 82-2-554-7200</p> <p>Malaysia - Kuala Lumpur Tel: 60-3-7651-7906</p> <p>Malaysia - Penang Tel: 60-4-227-8870</p> <p>Philippines - Manila Tel: 63-2-634-9065</p> <p>Singapore Tel: 65-6334-8870</p> <p>Taiwan - Hsin Chu Tel: 886-3-577-8366</p> <p>Taiwan - Kaohsiung Tel: 886-7-213-7830</p> <p>Taiwan - Taipei Tel: 886-2-2508-8600</p> <p>Thailand - Bangkok Tel: 66-2-694-1351</p> <p>Vietnam - Ho Chi Minh Tel: 84-28-5448-2100</p>	<p>Austria - Wels Tel: 43-7242-2244-39 Fax: 43-7242-2244-393</p> <p>Denmark - Copenhagen Tel: 45-4485-5910 Fax: 45-4485-2829</p> <p>Finland - Espoo Tel: 358-9-4520-820</p> <p>France - Paris Tel: 33-1-69-53-63-20 Fax: 33-1-69-30-90-79</p> <p>Germany - Garching Tel: 49-8931-9700</p> <p>Germany - Haan Tel: 49-2129-3766400</p> <p>Germany - Heilbronn Tel: 49-7131-72400</p> <p>Germany - Karlsruhe Tel: 49-721-625370</p> <p>Germany - Munich Tel: 49-89-627-144-0 Fax: 49-89-627-144-44</p> <p>Germany - Rosenheim Tel: 49-8031-354-560</p> <p>Israel - Ra'anana Tel: 972-9-744-7705</p> <p>Italy - Milan Tel: 39-0331-742611 Fax: 39-0331-466781</p> <p>Italy - Padova Tel: 39-049-7625286</p> <p>Netherlands - Drunen Tel: 31-416-690399 Fax: 31-416-690340</p> <p>Norway - Trondheim Tel: 47-72884388</p> <p>Poland - Warsaw Tel: 48-22-3325737</p> <p>Romania - Bucharest Tel: 40-21-407-87-50</p> <p>Spain - Madrid Tel: 34-91-708-08-90 Fax: 34-91-708-08-91</p> <p>Sweden - Gothenberg Tel: 46-31-704-60-40</p> <p>Sweden - Stockholm Tel: 46-8-5090-4654</p> <p>UK - Wokingham Tel: 44-118-921-5800 Fax: 44-118-921-5820</p>

X-ON Electronics

Largest Supplier of Electrical and Electronic Components

Click to view similar products for [8-bit Microcontrollers - MCU category](#):

Click to view products by [Microchip manufacturer](#):

Other Similar products are found below :

[CY8C28433-24PVXIT](#) [MB95F696KPMC-G-SNE2](#) [ISD-ES1600_USB_PROG](#) [HD64F2144AFA20](#) [STM8TL53G4U6](#) [MB95F778JPMC1-G-SNE2](#) [UPD78F0503AMC-CAB-AX](#) [MB95F202KPF-G-SNE2](#) [MB95F318EPMC-G-SNE2](#) [LC78615E-01US-H](#) [MB95F698KPMC-G-UNE2](#) [MB89F538-101PMC-GE1](#) [LC87FBK08AU-SSOP-H](#) [LC87F2C64AU-QFP-H](#) [MB95F636KNWQN-G-118-SNE1](#) [LC87F5NC8AVU-QIP-E](#) [STM8AL3168TAX](#) [STM8S007C8T6TR](#) [LC87F76C8AU-TQFP-E](#) [LC87F2G08AU-SSOP-E](#) [CP8085AT](#) [STM8TL52G4U6](#) [PIC18F57Q84-I/6MX](#) [AT89C51CC01UAT-RLTUM](#) [PIC18F4510-E/P](#) [AT89C51ED2T-RLTUM](#) [AT89C51RC2T-RLTUM](#) [AT89C51AC3T-RLTUM](#) [AT89C51CC01CAT-RLTUM](#) [AT89C51CC03UAT-RLTUM](#) [AT89C51RB2T-RLTUM](#) [AT89C51RD2T-RLTUM](#) [PIC18F27Q84-I/5N](#) [AVR32DD32-I/RXB](#) [PIC16F18056-I/SO](#) [MB95F272HPF-G-SNE2](#) [ST72F361AR9T6](#) [STM8AF5286UCX](#) [UPSD3312DV-40T6](#) [LC87F2416AU-EB-2E](#) [MB95F118NWPMC-GE1](#) [MB95F128NBPMC-GE1](#) [MB95F202HPF-G-SNE2](#) [MB95F202HP-G-SH-SNE2](#) [MB95F202KP-G-SH-SNE2](#) [MB95F203HPF-G-SNE2](#) [MB95F204HP-G-SH-SNE2](#) [MB95F204KP-G-SH-SNE2](#) [MB95F212KPF-G-SNE2](#) [MB95F212KPH-G-SNE2](#)