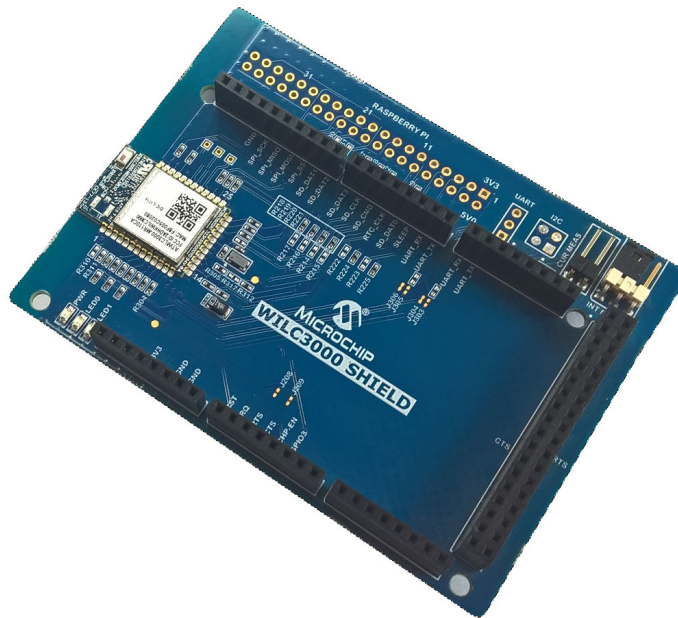

ATWILC3000 Shield User Guide

Introduction

The ATWILC3000 Shield is an interface board designed to demonstrate the ATWILC3000-MR110CA, a single chip IEEE[®] 802.11 b/g/n RF/Baseband/MAC network controller with Bluetooth[®] Low Energy. This module is optimized for low-power applications. The ATWILC3000 module can be connected to the host MCU board using any of the following interfaces:

- For Wi-Fi[®], either Secure Digital Input/Outputs (SDIO) or Serial Peripheral Interface (SPI) is used.
- For Bluetooth, Universal Asynchronous Receiver/Transmitter (UART) is used.

Figure 1. ATWILC3000 Shield Board



Features

- Debug I²C and UART Header Footprints
- External Power Supply Header
- Current Measurement Header
- Power and User LED
- Chip Antenna
- Supports 32.768 kHz Low-Power Surface Mount Device (SMD) Crystal Oscillator
- Arduino Shield Stacking Connector
 - Supports Wi-Fi through SDIO by default. Pinout is compatible with ATSAMA5D4-XULT

- Supports Wi-Fi through SPI (optional). Pinout is compatible with Arduino header specification
- Supports Bluetooth through UART
- Raspberry Pi Stacking Connector
 - Supports Wi-Fi through SDIO or SPI
 - Supports Bluetooth through UART

Table of Contents

Introduction.....	1
Features.....	1
1. Kit Overview.....	4
2. ATWILC3000 Shield Peripheral Configuration.....	5
3. Design Documentation and Relevant Links.....	6
4. Hardware Specifications.....	7
4.1. ATWILC3000 Shield Arduino Shield Stacking Connectors.....	7
4.2. ATWILC3000 Shield Raspberry Pi Stacking Connector.....	9
4.3. Power Supply Connector.....	11
4.4. Current Measurement Header.....	11
4.5. Debug Connectors.....	11
5. CE and FCC.....	13
6. Hardware Revision History and Known Issues.....	14
6.1. Identifying Product ID and Revision.....	14
6.2. Revision.....	14
7. Document Revision History.....	15
The Microchip Web Site.....	16
Customer Change Notification Service.....	16
Customer Support.....	16
Microchip Devices Code Protection Feature.....	16
Legal Notice.....	17
Trademarks.....	17
Quality Management System Certified by DNV.....	18
Worldwide Sales and Service.....	19

1. Kit Overview

The ATWILC3000 Shield is a shield board containing the low-power ATWILC3000-MR110CA 802.11 b/g/n IoT module. By default, the ATWILC3000 Shield is configured to use with the SDIO interface which is compatible with SAMA5D4-XULT.

Figure 1-1. ATWILC3000 Shield Evaluation Kit Overview

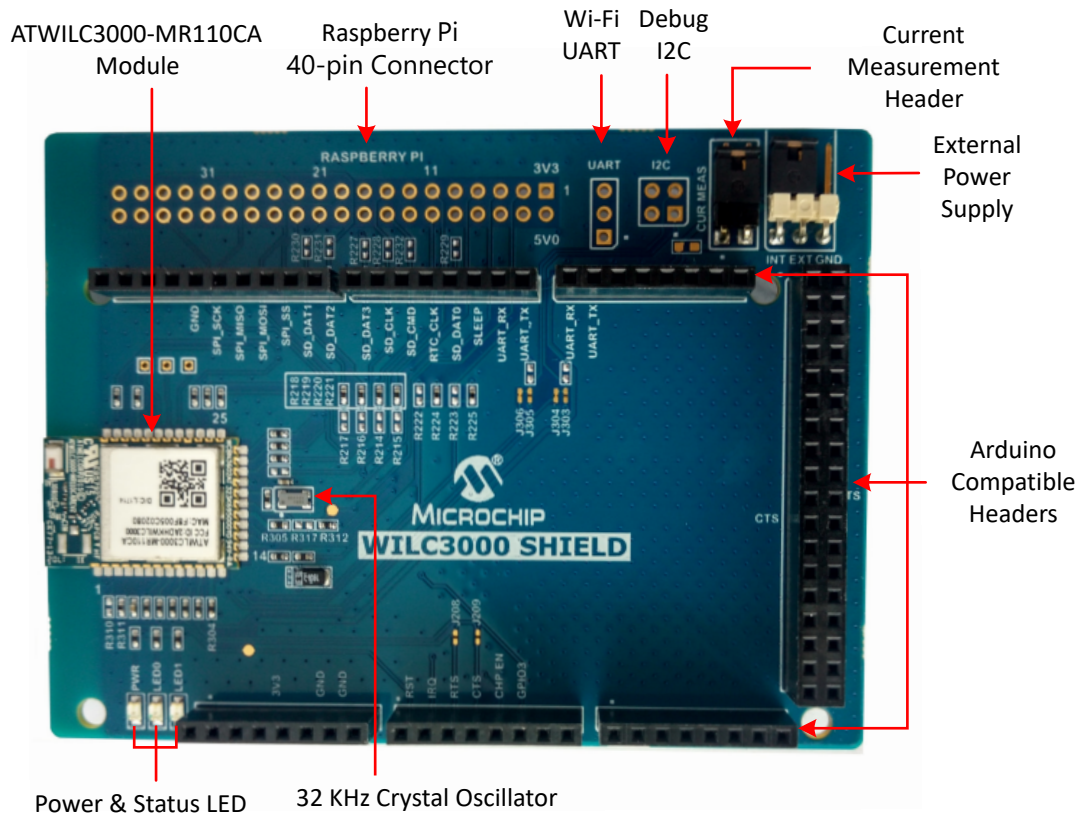

The ATWILC3000 Shield can also be configured to use with other host MCU boards using SPI peripheral interface exposed through Arduino compatible connectors. For more details, see [ATWILC3000 Wiki](#) for the list of supported boards and related documents.

2. ATWILC3000 Shield Peripheral Configuration

The ATWILC3000 module on the shield board can communicate with the host board using either SDIO or SPI. By default, SDIO is supported. A resistor combination must be modified to add SPI support. The following table provides resistor configuration details.

Table 2-1. ATWILC3000 Shield Resistor Configuration for SDIO/SPI

Peripheral Interface	Required Modification for Resistors
SDIO	Mounted resistors: R311, R218, R219, R220, R221 Not mounted resistors: R214, R215, R216, R217, R310
SPI	Mounted resistors: R214, R215, R216, R217, R310 Not mounted resistors: R218, R219, R220, R221, R311

Figure 2-1. ATWILC3000 Shield SDIO-SPI Resistors

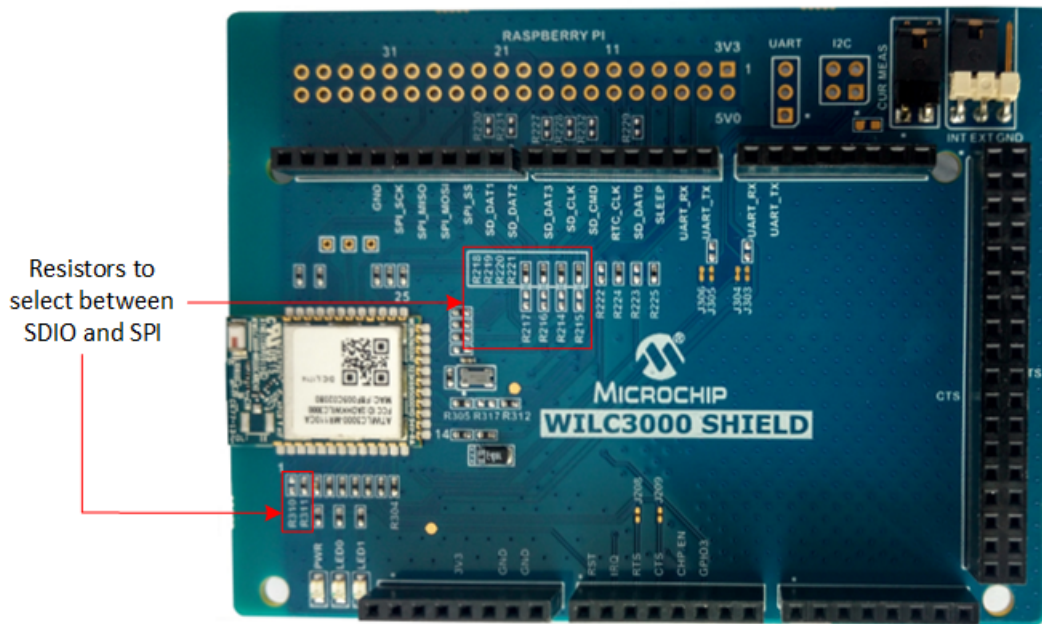

3. Design Documentation and Relevant Links

The following list contains links to the most relevant documents and software available for the ATWILC3000 Shield.

- **Xplained Boards** is a series of small-sized and easy-to-use evaluation kits for microcontrollers and other products. It consists of low-cost MCU boards for evaluation and demonstration of features and capabilities of different MCU families.
- **Atmel Studio** provides a free Atmel IDE for development of C/C++ and assembler code for microcontrollers.
- **Data Visualizer** is a program used for processing and visualizing data. The Data Visualizer can receive data from various sources, such as the embedded debugger data gateway interface found on Xplained Pro boards and COM ports.
- **ATWILC3000** page provides information and documentation on the Microchip ATWILC3000-MR110CA module.
- **ATWILC3000 Wireless Wiki** page is an online directory to access source code and documentation for the ATWILC3000.
- **SMART SAMA5 ARM® Cortex® based MPUs** page is an online directory to access the tools and software for SAMA5 Cortex-A5-Based Embedded MPUs.

4. Hardware Specifications

This chapter describes the connectors and header of the ATWILC 3000 Shield board.

4.1 ATWILC3000 Shield Arduino Shield Stacking Connectors

The ATWILC3000 Shield contains Arduino shield stacking connectors, which are used to connect the board to an MCU base board. This is also used to expose the unused pins to the user. The pinout definition for the shield connectors are given in the following tables.

Table 4-1. J200 Stacking Connector

Pin Number	Function	Description
1	SD_DAT2	SDIO Data 2
2	SD_DAT1	SDIO Data 1
3	SPI_SS	SPI select. By default, this pin is not connected. Mount R217 (0Ω) to connect.
4	SPI_MOSI	SPI MOSI. By default, this pin is not connected. Mount R216 (0Ω) to connect.
5	SPI_MISO	SPI MISO. By default, this pin is not connected. Mount R215 (0Ω) to connect.
6	SPI_SCK	SPI Clock. By default, this pin is not connected. Mount R214 (0Ω) to connect.
7	GND	Ground
8	NC	Not connected
9	NC	Not connected
10	NC	Not connected

Table 4-2. J201 Stacking Connector

Pin Number	Function	Description
1	NC	Not connected
2	NC	Not connected
3	NC	Not connected
4	VCC_INT_P3V3	3.3V power supply. Mount jumper cap on J300-1 and J300-2 to use this supply.
5	NC	Not connected
6	GND	Ground
7	GND	Ground
8	NC	Not connected

Table 4-3. J202 Stacking Connector

Pin Number	Function	Description
1	SD_DAT3	SDIO Data 3
2	SD_CLK	SDIO Clock
3	SD_CMD	SDIO command
4	PWML2/RTC_CLK	By default, this pin is not connected. Mount R315 (0Ω) to connect.
5	SD_DAT0	SDIO Data 0
6	SLEEP	Sleep mode control
7	UART_RX	Bluetooth® UART RXD. By default, this pin is not connected. Mount R222 (0Ω) to connect.
8	UART_TX	Bluetooth® UART TXD. By default, this pin is not connected. Mount R223 (0Ω) to connect.

Table 4-4. J203 Stacking Connector

Pin Number	Function	Description
1	RST	ATWILC3000 Reset to be controlled by the host MCU
2	IRQN	Host interrupt request output
3	RTS	Bluetooth® UART RTS output. By default, this pin is not connected. Short J208 to connect.
4	CTS	Bluetooth® UART CTS input. By default, this pin is not connected. Short J209 to connect.
5	CHIP_EN	Chip enable
6	GPIO3/SUSPEND	GPIO signal
7	NC	Not connected
8	NC	Not connected

Table 4-5. J204 Stacking Connector

Pin Number	Function	Description
1	UART_RX_1	Bluetooth® UART receive
2	UART_TX_1	Bluetooth® UART transmit
3	NC	Not connected
4	NC	Not connected
5	NC	Not connected
6	NC	Not connected

Pin Number	Function	Description
7	NC	Not connected
8	NC	Not connected

Table 4-6. J206 Stacking Connector

Pin Number	Function	Description
20	UART_RTS	Bluetooth® UART RTS output
21	UART_CTS	Bluetooth® UART CTS input
35	GND	Ground
36	GND	Ground

4.2 ATWILC3000 Shield Raspberry Pi Stacking Connector

The ATWILC3000 Shield contains a Raspberry Pi compatible 40-pin stacking connector used to connect the board to a Raspberry Pi base board. This is also used for exposing the unused pins to the user. The pinout definition for the Raspberry Pi connector is given in the following table.

Table 4-7. J207 Stacking Connector

Pin Number	Function	Description
1	VCC_INT_P3V3	3.3V power supply. Insert jumper cap on J300-1 and J300-2 to use this power supply.
2	NC	Not connected
3	GPIO2/SUSPEND	GPIO signal
4	NC	Not connected
5	CHIP_EN	ATWILC3000 Chip enable is controlled by the host MCU
6	GND	Ground
7	IRQN	Host interrupt request output
8	UART_RX	Bluetooth® UART receive
9	GND	Ground
10	UART_TX	Bluetooth® UART transmit
11	CTS	Bluetooth® UART CTS input
12	GEN1/RTC_CLK	By default, this pin is not connected. Mount R315 (0Ω) to connect.
13	SDDATA3	SDIO Data 3. By default, this pin is not connected. Mount R227 (0Ω) to connect.
14	GND	Ground

ATWILC3000

Hardware Specifications

Pin Number	Function	Description
15	SDCLK	SDIO Clock. By default, this pin is not connected. Mount R228 (0Ω) to connect.
16	SDCMD	SDIO Command. By default, this pin is not connected. Mount R232 (0Ω) to connect.
17	NC	Not connected
18	SDDATA0	SDIO Data 0. By default this pin is not connected. Mount R229 (0 Ω) to connect.
19	SPI MOSI	SPI Master Output Slave Input. By default, this pin is not connected. Mount R216 (0Ω) to connect.
20	GND	Ground
21	SPI MISO	SPI Master Input Slave Output. By default this pin is not connected. Mount R215 (0Ω) to connect.
22	SDDATA1	SDIO Data 1. By default, this pin is not connected. Mount R230 (0Ω) to connect.
23	SPI SCLK	SPI Clock. By default, this pin is not connected. Mount R214 (0Ω) to connect.
24	SPI CS0	SPI Select. By default, this pin is not connected. Mount R217 (0Ω) to connect.
25	GND	Ground
26	SLEEP	Sleep mode control
27	NC	Not connected
28	NC	Not connected
29	NC	Not connected
30	GND	Ground
31	NC	Not connected
32	RST	ATWILC3000 Reset is controlled by host MCU
33	NC	Not connected
34	GND	Ground
35	NC	Not connected
36	RTS	Bluetooth [®] UART receive output. By default, this pin is not connected. Short J208 to connect.
37	SDDATA2	SDIO Data 2. By default, this pin is not connected. Mount R231 (0Ω) to connect.
38	NC	Not connected

Pin Number	Function	Description
39	GND	Ground
40	NC	Not connected

4.3 Power Supply Connector

The ATWILC3000 Shield is powered either from the shield connector or from an external power supply. The header (J300) is used to switch between 3.3V supply from the shield connector or a 3.3V external power supply. The following tables provide pin details and the connector configuration of the power supply connector.

Table 4-8. ATWILC3000-SHLD J300 Power Supply Connector

Pin Number	Description
1	3.3V internal power supply from shield connector
2	3.3V external power supply
3	Ground

Table 4-9. ATWILC3000-SHLD Power Supply Connector Configuration

Power Supply	J300 Connector Configuration
To set 3.3V power supply from either Arduino Shield or Raspberry Pi	Place jumper cap between J300-1 and J300-2, and J300-3 must not be not connected.
To set 3.3V external power supply	Remove jumper cap from J300-1 and J300-2. Apply external power to J300-2 and J300-3.

4.4 Current Measurement Header

The current measurement header (J301) is used to measure the current consumed by the ATWILC3000 module using an ammeter. There are two 0Ω resistors, R304 and R305, that can be used to measure the current consumed by individual power rails, such as VDDIO, and VBAT respectively.

4.5 Debug Connectors

The debug I²C (J302) and Wi-Fi UART (J307) connectors are not mounted on the board. The following table provides a description of the connectors.

Table 4-10. Debug I²C Connector

Pin on I ² C Connector	Pin on ATWILC3000 Module	Function
1	10	I ² C SCL
2	1	Ground
3	11	I ² C SDA
4	—	Not connected

Table 4-11. Wi-Fi UART Connector

Pin on Extension Port	Pin on ATWILC3000 Module	Function
1	17	UART Receiver
2	16	UART Transmitter
3	1	Ground

5. CE and FCC

The unit is tested at SDIO clock frequency of 29.34 MHz in accordance to the essential requirements and other relevant provisions of:

- Emission
 - FCC part 15 subpart B: 2013 (Class B) EN 55022:2010 Class B
 - EN 55024:2010 Class B
- Immunity
 - EN 55024:2010
 - EN 61000-4-2:2009 contact: level 2 ($\pm 4\text{kV}$), air: level 2 ($\pm 8\text{kV}$)
 - EN 61000-4-3:2006+A2:2010, 80 MHz to 1000 MHz, level 2 (3V/m)
 - EN 61000-4-8:2010 level 2 (3A/m), continuous field

The technical construction file is located at:

```
Microchip Norway  
Vestre Rosten 79  
7075 Tiller  
Norway
```

Every effort is made to minimize the electromagnetic emissions from the product. However, under certain conditions, the system (this product connected to a target application circuit) may emit individual electromagnetic component frequencies, which exceed the maximum values allowed by the above mentioned standards. The frequency and magnitude of the emissions are determined by several factors, including layout and routing of the target application, where the product is used.

6. Hardware Revision History and Known Issues

6.1 Identifying Product ID and Revision

The revision and product identifier of the ATWILC3000 Shield is available on the sticker on the bottom side of the PCB. The identifier and revision are printed in plain text as A09-nnnn\rr, where nnnn is the identifier and rr is the revision. In addition, the label contains a 10-digit serial number unique to each board.

The product identifier for the ATWILC3000 Shield is A09-2616.

6.2 Revision

Revision 4 is the initially released revision and there are no known issues.

Revision 5 has J302 and J303 as Do Not Populate.

Revision 6 and 7 has the dimension of PCB cutout reduced from 14.68 mm to 11.84 mm, as per the ATWILC3000-MR110CA module datasheet recommendation for improved radiated performance.

7. Document Revision History

Rev A - 06/2018

Section	Changes
Document	<ul style="list-style-type: none">• Updated all the links in Design Documentation and Relevant Links section• Updated the functions and descriptions of J207 Stacking Connector• Added hardware revision details for Revision 5, 6 and 7• Updated the document from Atmel to Microchip template• Assigned a new Microchip document number

Previously Released Atmel Revisions

Doc. Rev.	Date	Comment
42731B	04/2017	Added section regulatory notice with Argentina certification information
42731A	05/2016	Initial document release

The Microchip Web Site

Microchip provides online support via our web site at <http://www.microchip.com/>. This web site is used as a means to make files and information easily available to customers. Accessible by using your favorite Internet browser, the web site contains the following information:

- **Product Support** – Data sheets and errata, application notes and sample programs, design resources, user's guides and hardware support documents, latest software releases and archived software
- **General Technical Support** – Frequently Asked Questions (FAQ), technical support requests, online discussion groups, Microchip consultant program member listing
- **Business of Microchip** – Product selector and ordering guides, latest Microchip press releases, listing of seminars and events, listings of Microchip sales offices, distributors and factory representatives

Customer Change Notification Service

Microchip's customer notification service helps keep customers current on Microchip products. Subscribers will receive e-mail notification whenever there are changes, updates, revisions or errata related to a specified product family or development tool of interest.

To register, access the Microchip web site at <http://www.microchip.com/>. Under "Support", click on "Customer Change Notification" and follow the registration instructions.

Customer Support

Users of Microchip products can receive assistance through several channels:

- Distributor or Representative
- Local Sales Office
- Field Application Engineer (FAE)
- Technical Support

Customers should contact their distributor, representative or Field Application Engineer (FAE) for support. Local sales offices are also available to help customers. A listing of sales offices and locations is included in the back of this document.

Technical support is available through the web site at: <http://www.microchip.com/support>

Microchip Devices Code Protection Feature

Note the following details of the code protection feature on Microchip devices:

- Microchip products meet the specification contained in their particular Microchip Data Sheet.
- Microchip believes that its family of products is one of the most secure families of its kind on the market today, when used in the intended manner and under normal conditions.
- There are dishonest and possibly illegal methods used to breach the code protection feature. All of these methods, to our knowledge, require using the Microchip products in a manner outside the operating specifications contained in Microchip's Data Sheets. Most likely, the person doing so is engaged in theft of intellectual property.
- Microchip is willing to work with the customer who is concerned about the integrity of their code.

- Neither Microchip nor any other semiconductor manufacturer can guarantee the security of their code. Code protection does not mean that we are guaranteeing the product as “unbreakable.”

Code protection is constantly evolving. We at Microchip are committed to continuously improving the code protection features of our products. Attempts to break Microchip’s code protection feature may be a violation of the Digital Millennium Copyright Act. If such acts allow unauthorized access to your software or other copyrighted work, you may have a right to sue for relief under that Act.

Legal Notice

Information contained in this publication regarding device applications and the like is provided only for your convenience and may be superseded by updates. It is your responsibility to ensure that your application meets with your specifications. MICROCHIP MAKES NO REPRESENTATIONS OR WARRANTIES OF ANY KIND WHETHER EXPRESS OR IMPLIED, WRITTEN OR ORAL, STATUTORY OR OTHERWISE, RELATED TO THE INFORMATION, INCLUDING BUT NOT LIMITED TO ITS CONDITION, QUALITY, PERFORMANCE, MERCHANTABILITY OR FITNESS FOR PURPOSE. Microchip disclaims all liability arising from this information and its use. Use of Microchip devices in life support and/or safety applications is entirely at the buyer’s risk, and the buyer agrees to defend, indemnify and hold harmless Microchip from any and all damages, claims, suits, or expenses resulting from such use. No licenses are conveyed, implicitly or otherwise, under any Microchip intellectual property rights unless otherwise stated.

Trademarks

The Microchip name and logo, the Microchip logo, AnyRate, AVR, AVR logo, AVR Freaks, BitCloud, chipKIT, chipKIT logo, CryptoMemory, CryptoRF, dsPIC, FlashFlex, flexPWR, Heldo, JukeBlox, KeeLoq, Klear, LANCheck, LINK MD, maXStylus, maXTouch, MediaLB, megaAVR, MOST, MOST logo, MPLAB, OptoLyzer, PIC, picoPower, PICSTART, PIC32 logo, Prochip Designer, QTouch, SAM-BA, SpyNIC, SST, SST Logo, SuperFlash, tinyAVR, UNI/O, and XMEGA are registered trademarks of Microchip Technology Incorporated in the U.S.A. and other countries.

ClockWorks, The Embedded Control Solutions Company, EtherSynch, Hyper Speed Control, HyperLight Load, IntelliMOS, mTouch, Precision Edge, and Quiet-Wire are registered trademarks of Microchip Technology Incorporated in the U.S.A.

Adjacent Key Suppression, AKS, Analog-for-the-Digital Age, Any Capacitor, AnyIn, AnyOut, BodyCom, CodeGuard, CryptoAuthentication, CryptoAutomotive, CryptoCompanion, CryptoController, dsPICDEM, dsPICDEM.net, Dynamic Average Matching, DAM, ECAN, EtherGREEN, In-Circuit Serial Programming, ICSP, INICnet, Inter-Chip Connectivity, JitterBlocker, KlearNet, KlearNet logo, memBrain, Mindi, MiWi, motorBench, MPASM, MPF, MPLAB Certified logo, MPLIB, MPLINK, MultiTRAK, NetDetach, Omniscient Code Generation, PICDEM, PICDEM.net, PICKit, PICtail, PowerSmart, PureSilicon, QMatrix, REAL ICE, Ripple Blocker, SAM-ICE, Serial Quad I/O, SMART-I.S., SQI, SuperSwitcher, SuperSwitcher II, Total Endurance, TSHARC, USBCheck, VariSense, ViewSpan, WiperLock, Wireless DNA, and ZENA are trademarks of Microchip Technology Incorporated in the U.S.A. and other countries.

SQTP is a service mark of Microchip Technology Incorporated in the U.S.A.

Silicon Storage Technology is a registered trademark of Microchip Technology Inc. in other countries.

GestIC is a registered trademark of Microchip Technology Germany II GmbH & Co. KG, a subsidiary of Microchip Technology Inc., in other countries.

All other trademarks mentioned herein are property of their respective companies.

© 2018, Microchip Technology Incorporated, Printed in the U.S.A., All Rights Reserved.

ISBN: 978-1-5224-3263-0

Quality Management System Certified by DNV

ISO/TS 16949

Microchip received ISO/TS-16949:2009 certification for its worldwide headquarters, design and wafer fabrication facilities in Chandler and Tempe, Arizona; Gresham, Oregon and design centers in California and India. The Company's quality system processes and procedures are for its PIC[®] MCUs and dsPIC[®] DSCs, KEELOQ[®] code hopping devices, Serial EEPROMs, microperipherals, nonvolatile memory and analog products. In addition, Microchip's quality system for the design and manufacture of development systems is ISO 9001:2000 certified.

Worldwide Sales and Service

AMERICAS	ASIA/PACIFIC	ASIA/PACIFIC	EUROPE
<p>Corporate Office 2355 West Chandler Blvd. Chandler, AZ 85224-6199 Tel: 480-792-7200 Fax: 480-792-7277 Technical Support: http://www.microchip.com/support Web Address: www.microchip.com</p> <p>Atlanta Duluth, GA Tel: 678-957-9614 Fax: 678-957-1455</p> <p>Austin, TX Tel: 512-257-3370</p> <p>Boston Westborough, MA Tel: 774-760-0087 Fax: 774-760-0088</p> <p>Chicago Itasca, IL Tel: 630-285-0071 Fax: 630-285-0075</p> <p>Dallas Addison, TX Tel: 972-818-7423 Fax: 972-818-2924</p> <p>Detroit Novi, MI Tel: 248-848-4000</p> <p>Houston, TX Tel: 281-894-5983</p> <p>Indianapolis Noblesville, IN Tel: 317-773-8323 Fax: 317-773-5453 Tel: 317-536-2380</p> <p>Los Angeles Mission Viejo, CA Tel: 949-462-9523 Fax: 949-462-9608 Tel: 951-273-7800</p> <p>Raleigh, NC Tel: 919-844-7510</p> <p>New York, NY Tel: 631-435-6000</p> <p>San Jose, CA Tel: 408-735-9110 Tel: 408-436-4270</p> <p>Canada - Toronto Tel: 905-695-1980 Fax: 905-695-2078</p>	<p>Australia - Sydney Tel: 61-2-9868-6733</p> <p>China - Beijing Tel: 86-10-8569-7000</p> <p>China - Chengdu Tel: 86-28-8665-5511</p> <p>China - Chongqing Tel: 86-23-8980-9588</p> <p>China - Dongguan Tel: 86-769-8702-9880</p> <p>China - Guangzhou Tel: 86-20-8755-8029</p> <p>China - Hangzhou Tel: 86-571-8792-8115</p> <p>China - Hong Kong SAR Tel: 852-2943-5100</p> <p>China - Nanjing Tel: 86-25-8473-2460</p> <p>China - Qingdao Tel: 86-532-8502-7355</p> <p>China - Shanghai Tel: 86-21-3326-8000</p> <p>China - Shenyang Tel: 86-24-2334-2829</p> <p>China - Shenzhen Tel: 86-755-8864-2200</p> <p>China - Suzhou Tel: 86-186-6233-1526</p> <p>China - Wuhan Tel: 86-27-5980-5300</p> <p>China - Xian Tel: 86-29-8833-7252</p> <p>China - Xiamen Tel: 86-592-2388138</p> <p>China - Zhuhai Tel: 86-756-3210040</p>	<p>India - Bangalore Tel: 91-80-3090-4444</p> <p>India - New Delhi Tel: 91-11-4160-8631</p> <p>India - Pune Tel: 91-20-4121-0141</p> <p>Japan - Osaka Tel: 81-6-6152-7160</p> <p>Japan - Tokyo Tel: 81-3-6880-3770</p> <p>Korea - Daegu Tel: 82-53-744-4301</p> <p>Korea - Seoul Tel: 82-2-554-7200</p> <p>Malaysia - Kuala Lumpur Tel: 60-3-7651-7906</p> <p>Malaysia - Penang Tel: 60-4-227-8870</p> <p>Philippines - Manila Tel: 63-2-634-9065</p> <p>Singapore Tel: 65-6334-8870</p> <p>Taiwan - Hsin Chu Tel: 886-3-577-8366</p> <p>Taiwan - Kaohsiung Tel: 886-7-213-7830</p> <p>Taiwan - Taipei Tel: 886-2-2508-8600</p> <p>Thailand - Bangkok Tel: 66-2-694-1351</p> <p>Vietnam - Ho Chi Minh Tel: 84-28-5448-2100</p>	<p>Austria - Wels Tel: 43-7242-2244-39 Fax: 43-7242-2244-393</p> <p>Denmark - Copenhagen Tel: 45-4450-2828 Fax: 45-4485-2829</p> <p>Finland - Espoo Tel: 358-9-4520-820</p> <p>France - Paris Tel: 33-1-69-53-63-20 Fax: 33-1-69-30-90-79</p> <p>Germany - Garching Tel: 49-8931-9700</p> <p>Germany - Haan Tel: 49-2129-3766400</p> <p>Germany - Heilbronn Tel: 49-7131-67-3636</p> <p>Germany - Karlsruhe Tel: 49-721-625370</p> <p>Germany - Munich Tel: 49-89-627-144-0 Fax: 49-89-627-144-44</p> <p>Germany - Rosenheim Tel: 49-8031-354-560</p> <p>Israel - Ra'anana Tel: 972-9-744-7705</p> <p>Italy - Milan Tel: 39-0331-742611 Fax: 39-0331-466781</p> <p>Italy - Padova Tel: 39-049-7625286</p> <p>Netherlands - Drunen Tel: 31-416-690399 Fax: 31-416-690340</p> <p>Norway - Trondheim Tel: 47-7289-7561</p> <p>Poland - Warsaw Tel: 48-22-3325737</p> <p>Romania - Bucharest Tel: 40-21-407-87-50</p> <p>Spain - Madrid Tel: 34-91-708-08-90 Fax: 34-91-708-08-91</p> <p>Sweden - Gothenberg Tel: 46-31-704-60-40</p> <p>Sweden - Stockholm Tel: 46-8-5090-4654</p> <p>UK - Wokingham Tel: 44-118-921-5800 Fax: 44-118-921-5820</p>

X-ON Electronics

Largest Supplier of Electrical and Electronic Components

Click to view similar products for [WiFi Development Tools - 802.11 category](#):

Click to view products by [Microchip manufacturer](#):

Other Similar products are found below :

[YSAEWIFI-1](#) [SKY65981-11EK1](#) [QPF7221PCK-01](#) [SIMSA915C-Cloud-DKL](#) [SIMSA433C-Cloud-DKL](#) [ISM43903-R48-EVB-E](#)
[QPF4206BEVB01](#) [RN-G2SDK](#) [SKY85734-11EK1](#) [SKY85735-11EK1](#) [ENW49D01AZKF](#) [ESP-LAUNCHER](#) [MIKROE-2336](#)
[EVAL_PAN1760EMK](#) [3210](#) [EVAL_PAN1026EMK](#) [ATWINC1500-XPRO](#) [2471](#) [DM990001](#) [WRL-13711](#) [2999](#) [ATWILC3000-SHLD](#)
[DFR0321](#) [TEL0118](#) [3213](#) [DFR0489](#) [SLWSTK-COEXBP](#) [WRL-13804](#) [DEV-13907](#) [UP-3GHAT-A20-0001](#) [3405](#) [TEL0078](#) [2680](#) [2702](#)
[2821](#) [3606](#) [3653](#) [3654](#) [4000](#) [4172](#) [4178](#) [4201](#) [4264](#) [4285](#) [CS-ANAVI-25](#) [CS-ANAVI-26](#) [CS-ANAVI-23](#) [CS-ANAVI-24](#) [CS-ANAVI-28](#)
[CS-ANAVI-29](#)