

## Bluetooth® 4.2 Stereo Audio Module

### Features

- Qualified for Bluetooth v4.2 specifications
- Supports HFP 1.6, HSP 1.2, A2DP 1.3, SPP 1.2 and AVRCP 1.6
- Supports Bluetooth 4.2 dual-mode (BDR/EDR/ BLE) specifications (FW dependent)
- Stand-alone module with on-board PCB antenna and Bluetooth stack
- Supports high resolution up to 24-bit, 96 kHz audio data format
- Supports to connect two hosts with HFP/A2DP profiles simultaneously
- Supports to connect one host with SPP/BTLE
- Transparent UART mode for seamless serial data over UART interface
- Easy to configure with Windows® GUI or directly by external MCU
- Supports firmware field upgrade
- Supports one microphone
- Castellated surface mount pads for easy and reliable host PCB mounting
- RoHS compliant
- Ideal for portable battery operated devices
- Internal battery regulator circuitry

### DSP Audio Processing

- Supports 64 kbps A-Law,  $\mu$ -Law PCM format/ Continuous Variable Slope Delta (CVSD) modulation for SCO channel operation
- Supports 8/16 kHz noise suppression
- Supports 8/16 kHz echo cancellation
- Supports Modified Sub-Band Coding (MSBC) decoder for wide band speech
- Built-in High Definition Clean Audio (HCA) algorithms for both narrow band and wide band speech processing
- Packet loss concealment (PLC)
- Built-in audio effect algorithms to enhance audio streaming
- Supports Serial Copy Management System (SCMS-T) content protection

**FIGURE 1: BM63 MODULE**



### Audio Codec

- Sub-band Coding (SBC) and optional Advanced Audio Coding (AAC) decoding
- 20-bit digital-to-analog converter (DAC) with 98 dB SNR
- 16-bit analog-to-digital converter (ADC) with 92 dB SNR
- Supports up to 24-bit, 96 kHz I<sup>2</sup>S digital audio

### Peripherals

- Built-in lithium-ion and lithium-polymer battery charger (up to 350 mA)
- Integrated 1.8V and 3V configurable switching regulator and low-dropout (LDO) regulator
- Built-in ADC for battery voltage sense
- An AUX-In port for external audio input
- Three LED drivers
- Multiple I/O pins for control and status

# BM63

---

## RF/Analog

- Frequency spectrum: 2.402 GHz to 2.480 GHz
- Receive sensitivity: -90 dBm (2 Mbps EDR)
- Class 2 output power (+2 dBm typical)

## HCI Interface

- High-speed HCI-UART interface (supports up to 921,600 bps)

## MAC/Baseband Processor

- Supports Bluetooth 4.2 dual-mode (FW dependent)
  - BDR/EDR transport for audio, voice and SPP data exchange
  - BLE transport for proprietary transparent service and Apple Notification Center Service (ANCS) data exchange

## Operating Condition

- Operating voltage: 3.2V to 4.2V
- Operating temperature: -20°C to +70°C

## Compliance

- Bluetooth SIG QDID: 83345

## Applications

- Soundbar and Subwoofer (FW dependent)
- Bluetooth portable speaker phone
- Multi-speaker (FW dependent)

## Description

The BM63 module is a fully qualified Bluetooth v4.2 dual-mode (BDR/EDR/BLE) module for designers to add wireless audio and voice applications to their products. The BM63 module is a Bluetooth Special Interest Group (SIG) certified module that provides a complete wireless solution with a Bluetooth stack and an integrated PCB antenna in a compact surface-mount package.

The BM63 module has an integrated lithium-ion and lithium-polymer battery charger, and a digital audio interface. The module supports HSP, HFP, SPP, A2DP and AVRCP profiles, and AAC and SBC codecs.

## Table of Contents

1.0 Device Overview .....	5
2.0 Audio .....	13
3.0 Transceiver .....	17
4.0 Power Management Unit .....	19
5.0 Application Information .....	21
6.0 Printed Antenna Information .....	33
7.0 Physical Dimensions .....	37
8.0 Electrical Characteristics .....	39
9.0 Soldering Recommendations .....	47
10.0 Ordering Information .....	49
Appendix A: Revision History .....	51

### TO OUR VALUED CUSTOMERS

It is our intention to provide our valued customers with the best documentation possible to ensure successful use of your Microchip products. To this end, we will continue to improve our publications to better suit your needs. Our publications will be refined and enhanced as new volumes and updates are introduced.

If you have any questions or comments regarding this publication, please contact the Marketing Communications Department via E-mail at [docerrors@microchip.com](mailto:docerrors@microchip.com) or fax the **Reader Response Form** in the back of this data sheet to (480) 792-4150. We welcome your feedback.

#### Most Current Data Sheet

To obtain the most up-to-date version of this data sheet, please register at our Worldwide Web site at:

<http://www.microchip.com>

You can determine the version of a data sheet by examining its literature number found on the bottom outside corner of any page. The last character of the literature number is the version number, (e.g., DS30000000A is version A of document DS30000000).

#### Errata

An errata sheet, describing minor operational differences from the data sheet and recommended workarounds, may exist for current devices. As device/documentation issues become known to us, we will publish an errata sheet. The errata will specify the revision of silicon and revision of document to which it applies.

To determine if an errata sheet exists for a particular device, please check with one of the following:

- Microchip's Worldwide Web site; <http://www.microchip.com>
- Your local Microchip sales office (see last page)

When contacting a sales office, please specify which device, revision of silicon and data sheet (include literature number) you are using.

#### Customer Notification System

Register on our web site at [www.microchip.com](http://www.microchip.com) to receive the most current information on all of our products.

# BM63

---

NOTES:

## 1.0 DEVICE OVERVIEW

The BM63 module is built around Microchip Technology IS2063 SoC. The IS2063 SoC integrates the Bluetooth 4.2 dual-mode radio transceiver, Power Management Unit (PMU), crystal and DSP. Users can configure the BM63 module by using the UI tool and DSP tool, a Windows-based utility.

**Note:** The UI and DSP tools are available for download from the Microchip web site at: [www.microchip.com/BM63](http://www.microchip.com/BM63).

Figure 1-1 illustrates a typical example of the BM63 module which is connected to an external MCU and a DSP/codec.

**FIGURE 1-1: APPLICATION USING BM63 MODULE**

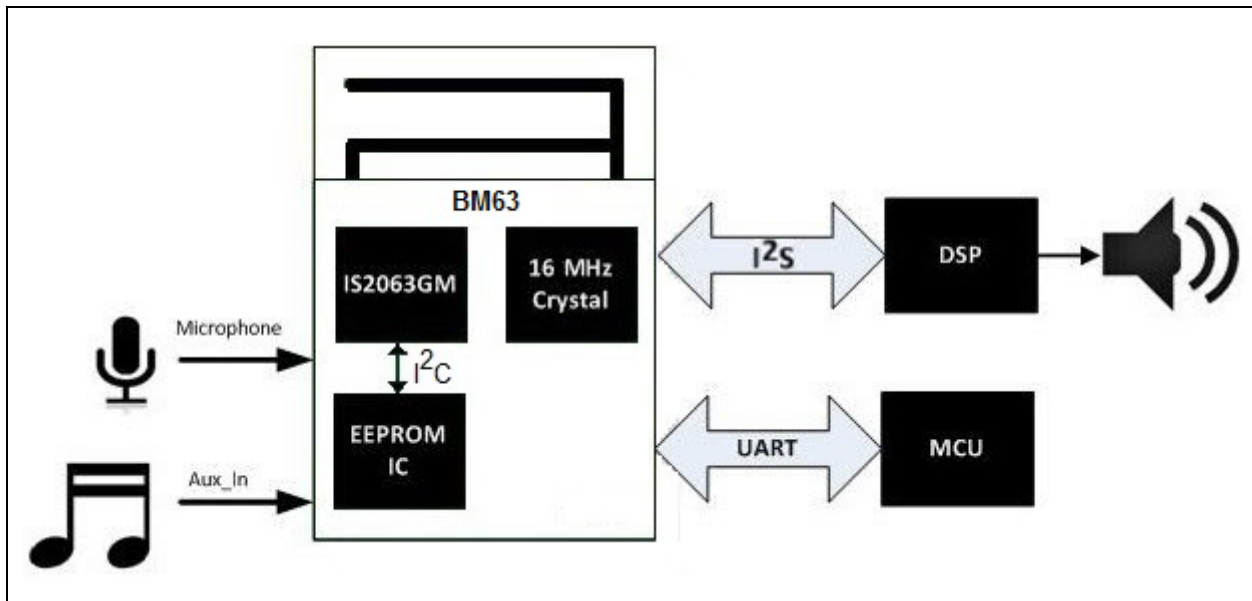


Figure 1-2 illustrates the Soundbar and Subwoofer applications using the BM63 module.

**FIGURE 1-2: SOUNDBAR AND SUBWOOFER APPLICATIONS USING BM63 MODULE**

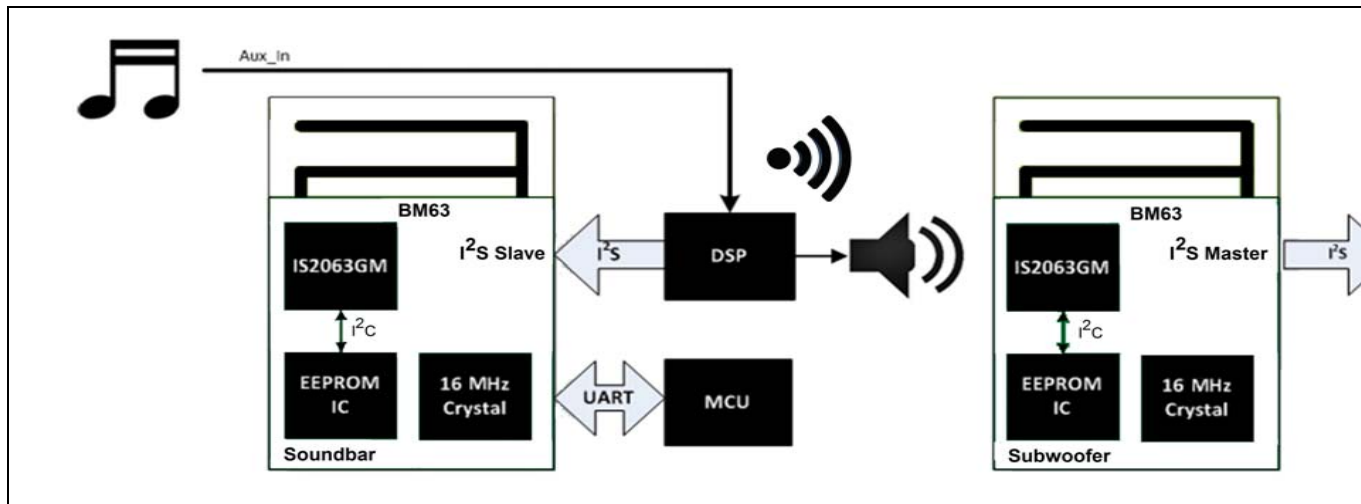


Figure 1-3 illustrates the Soundbar and Subwoofer applications using the BM63 module and smartphone.

**FIGURE 1-3: SOUNDBAR AND SUBWOOFER APPLICATIONS USING BM63 MODULE AND SMARTPHONE**

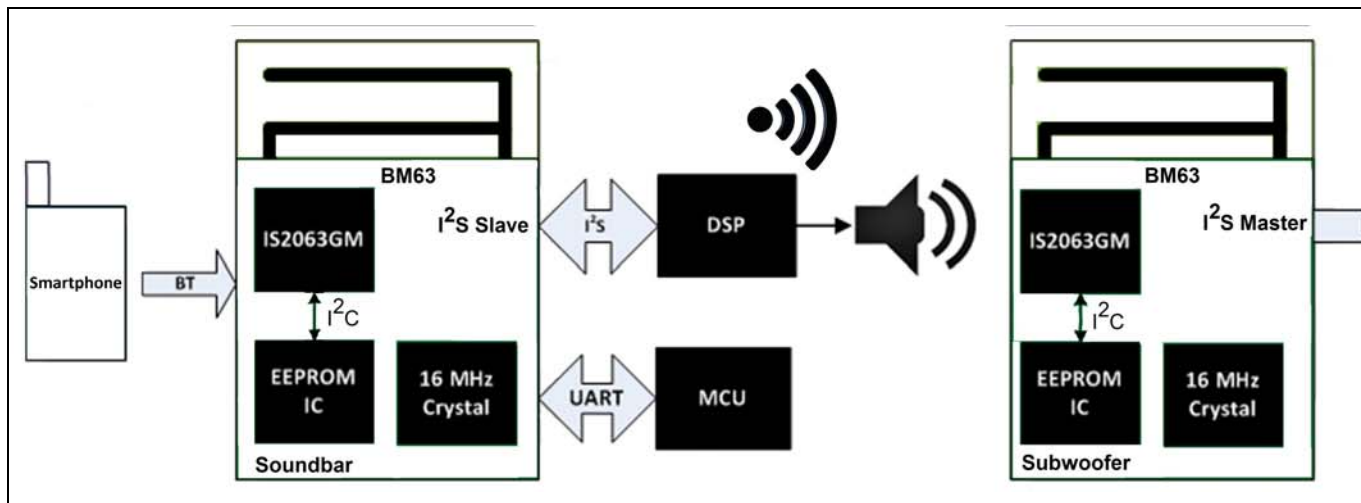
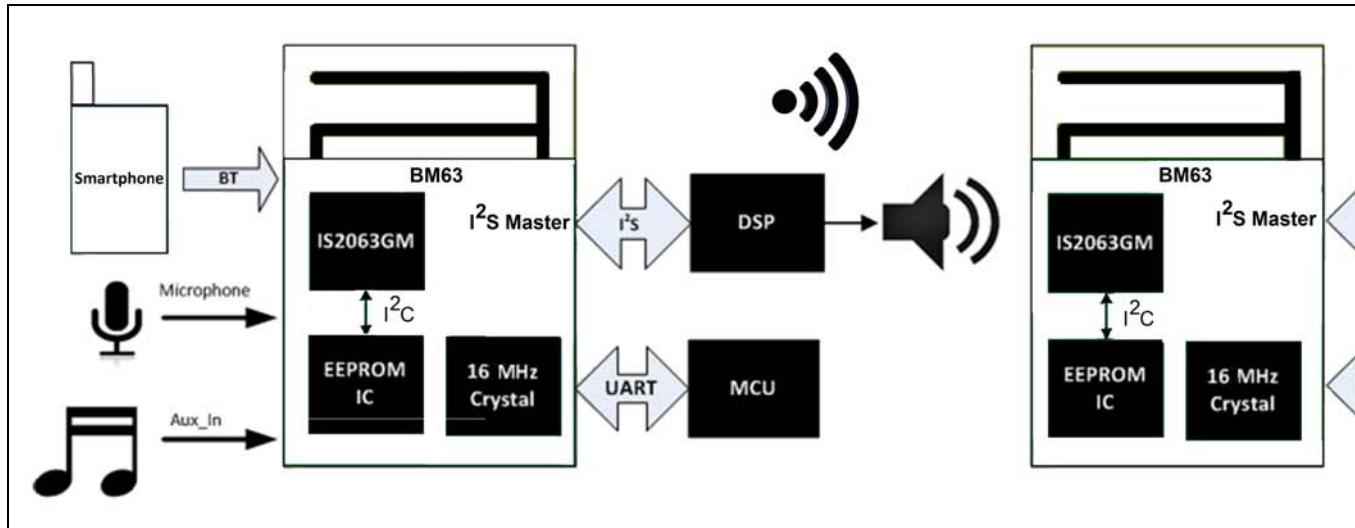


Figure 1-4 illustrates the Multi-speaker application using the BM63 module.

FIGURE 1-4: MULTI-SPEAKER APPLICATION USING BM63 MODULE



# BM63

Table 1-1 provides the key features of the BM63 module.

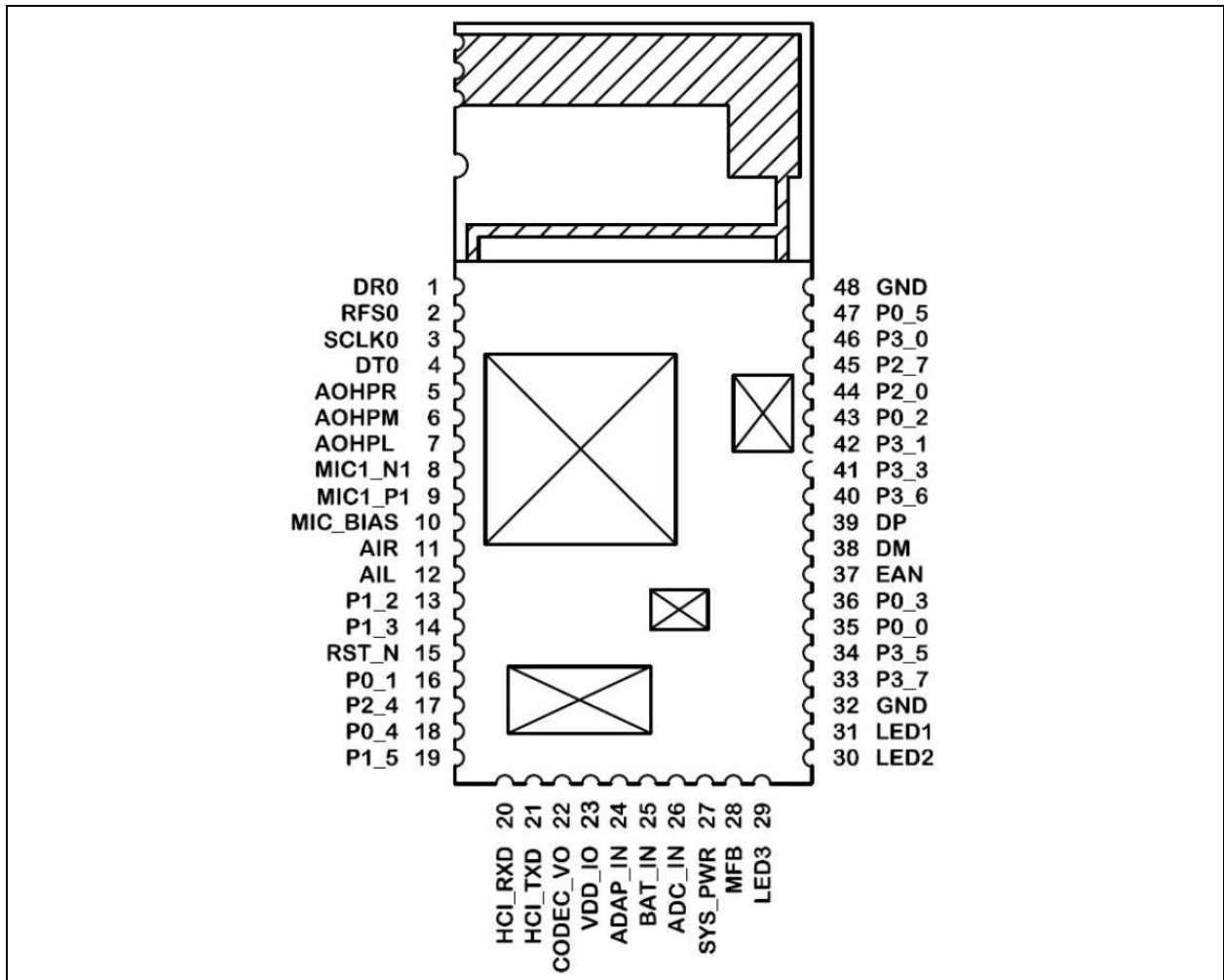
**TABLE 1-1: BM63 KEY FEATURES**

Feature	BM63
Application	Multi-speaker/Soundbar/Subwoofer
Stereo/mono	Stereo
Pin count	48
Dimensions (mm <sup>2</sup> )	15 x 32
PCB antenna	Yes
Tx power (typical)	2 dBm
Audio DAC output	2 Channel
DAC (single-ended) SNR at 2.8V (dB)	-98
DAC (capless) SNR at 2.8V (dB)	-98
ADC SNR at 2.8V (dB)	-92
I <sup>2</sup> S digital interface	Yes
Analog AUX-In	Yes
Mono MIC	1
External audio amplifier interface	Yes
UART	Yes
USB	Yes
LED driver	3
Internal DC-DC step down regulator	Yes
DC 5V adapter input	Yes
Battery charger (350 mA max)	Yes
ADC for thermal charger protection	No
Undervoltage protection (UVP)	No
GPIO	15
Button support	6
NFC (triggered by external NFC)	Yes
EEPROM	Yes
Voice prompt (FW dependent)	8K Sampling Rate, stored in EEPROM with approximately 800 bytes/second
Multi-tone	Yes
DSP sound effect	Yes
BLE	Yes
Bluetooth profiles	
HFP	1.6
AVRCP	1.6
A2DP	1.3
HSP	1.2
SPP	1.2



Figure 1-5 illustrates the pin diagram of the BM63 module.

**FIGURE 1-5: BM63 MODULE PIN DIAGRAM**



# BM63

Table 1-2 provides the pin description of the BM63 module.

**TABLE 1-2: BM63 MODULE PIN DESCRIPTION**

Pin No	Pin Type	Name	Description
1	I	DR0	I <sup>2</sup> S interface: digital left/right data
2	I/O	RFS0	I <sup>2</sup> S interface: left/right clock
3	I/O	SCLK0	I <sup>2</sup> S interface: bit clock
4	O	DT0	I <sup>2</sup> S interface: digital left/right data
5	O	AOHPR	Right-channel, analog headphone output
6	O	AOHPM	Headphone common mode output/sense input
7	O	AOHPL	Left-channel, analog headphone output
8	I	MIC_N1	MIC1 mono differential analog negative input
9	I	MIC_P1	MIC1 mono differential analog positive input
10	P	MIC_BIAS	Electric microphone biasing voltage
11	I	AIR	Right-channel, single-ended analog input
12	I	AIL	Left-channel, single-ended analog input
13	I/O	P1_2	EEPROM clock SCL
14	I/O	P1_3	EEPROM data SDA
15	I	RST_N	System Reset (active-low)
16	I/O	P0_1	Configurable control or indication pin (Internally pulled-up if configured as an input) <ul style="list-style-type: none"> <li>FWD key when Class 2 RF (default), active-low</li> <li>Class 1 Tx control signal for external RF Tx/Rx switch, active-high</li> </ul>
17	I/O	P2_4	System configuration pin along with P2_0 and EAN pins used to set the module in any one of these modes: <ul style="list-style-type: none"> <li>Application mode (for normal operation)</li> <li>Test mode (to change EEPROM values)</li> <li>Write Flash mode (to load a new firmware into the module), refer to <a href="#">Table 5-1</a></li> </ul>
18	I/O	P0_4	Configurable control or indication pin (Internally pulled-up if configured as an input) <ul style="list-style-type: none"> <li>NFC detection pin, active-low</li> <li>Out_Ind_1</li> </ul>
19	I/O	P1_5	Configurable control or indication pin (Internally pulled-up if configured as an input) <ul style="list-style-type: none"> <li>NFC detection pin, active-low</li> <li>Slide switch detector, active-high</li> <li>Out_Ind_1</li> <li>Multi-SPK Master/Slave mode control (FW dependent)</li> </ul>
20	I	HCI_RXD	HCI-UART data input
21	O	HCI_TXD	HCI-UART data output
22	P	CODEC_VO	Power supply/reference voltage for codec. Do not connect, for internal use only
23	P	VDD_IO	I/O positive supply. Do not connect, for internal use only
24	P	ADAP_IN	5V power adapter input

**TABLE 1-2: BM63 MODULE PIN DESCRIPTION (CONTINUED)**

Pin No	Pin Type	Name	Description
25	P	BAT_IN	Battery input. Voltage range: 3.2V to 4.2V. When an external power supply is connected to the ADAP_IN pin, the BAT_IN pin can be left open if battery is not connected.
26	P	ADC_IN	Analog input
27	P	SYS_PWR	System power output derived from ADAP_IN or BAT_IN
28	I	MFB	<ul style="list-style-type: none"> <li>Multi-Function Button and power-on key</li> <li>UART RX_IND, active-high (used by host MCU to wakeup the Bluetooth system)</li> </ul>
29	I	LED3	LED driver 3
30	I	LED2	LED driver 2
31	I	LED1	LED driver 1
32	P	GND	Ground reference
33	I/O	P3_7	Configurable control or indication pin (Internally pulled-up if configured as an input) UART TX_IND, active-low (used by Bluetooth system to wakeup the host MCU)
34	I/O	P3_5	Configurable control or indication pin (Internally pulled-up, if configured as an input) <ul style="list-style-type: none"> <li>Slide switch detector, active-high</li> </ul>
35	I/O	P0_0	Configurable control or indication pin (Internally pulled-up if configured as an input) <ul style="list-style-type: none"> <li>Slide switch detector, active-high, Out_Ind_0</li> </ul>
36	I/O	P0_3	Configurable control or indication pin (Internally pulled-up if configured as an input) <ul style="list-style-type: none"> <li>REV key (default), active-low</li> <li>Buzzer signal output</li> <li>Out_Ind_2</li> <li>Class 1 Rx Control signal of external RF Tx/Rx switch, active-high</li> </ul>
37	I	EAN	External address bus negative; must be pulled-down with 4.7 kOhm to GND System configuration pin along with P2_0 and P2_4 pins, used to set the module in any one of these modes: <ul style="list-style-type: none"> <li>Application mode (for normal operation)</li> <li>Test mode (to change EEPROM values)</li> <li>Write Flash mode (to load a new firmware into the module), refer to <a href="#">Table 5-1</a></li> </ul>
38	I/O	DM	Differential data-minus USB
39	I/O	DP	Differential data-plus USB
40	I/O	P3_6	Configurable control or indication pin (Internally pulled-up if configured as an input) Multi-SPK Master/Slave mode control (FW dependent)
41	I/O	P3_3	Configurable control or indication pin (Internally pulled-up if configured as an input) FWD key (default), active-low
42	I/O	P3_1	Configurable control or indication pin (Internally pulled-up if configured as an input) REV key (default), active-low

# BM63

**TABLE 1-2: BM63 MODULE PIN DESCRIPTION (CONTINUED)**

Pin No	Pin Type	Name	Description
43	I/O	P0_2	Configurable control or indication pin (Internally pulled-up if configured as an input) Play/Pause key (default)
44	I/O	P2_0	System configuration pin along with P2_4 and EAN pins used to set the module in one of these modes: <ul style="list-style-type: none"><li>• Application mode (for normal operation)</li><li>• Test mode (to change EEPROM values)</li><li>• Write Flash mode (to load a new firmware into the module), refer to <a href="#">Table 5-1</a></li><li>• Pulse/PWM signal output</li></ul>
45	I/O	P2_7	Configurable control or indication pin (Internally pulled-up if configured as an input) Volume-up key (default), active-low
46	I/O	P3_0	Configurable control or indication pin (Internally pulled-up if configured as an input) AUX-In detector, active-low
47	I/O	P0_5	Configurable control or indication pin (Internally pulled-up if configured as an input) Volume-down key (default), active-low
48	P	GND	Ground reference

**Legend:** I= Input pin      O= Output pin      I/O= Input/Output pin      P= Power pin

**Note:** All I/O pins can be configured using the UI tool, a Windows utility.

## 2.0 AUDIO

The input and output audios have different stages and each stage can be programmed to vary the characteristics of the gain response. For microphones, both single-ended inputs and differential inputs are supported. To maintain a high quality signal, a stable bias voltage source to the condenser microphone's FET is provided. The DC blocking capacitors can be used at both positive and negative sides of a input. Internally, this analog signal is converted to 16-bit, 8/16 kHz linear PCM data.

### 2.1 Digital Signal Processor

A Digital Signal Processor (DSP) is used to perform speech and audio processing. The advanced speech features, such as acoustic echo cancellation and noise reduction are inbuilt. To reduce nonlinear distortion and to help echo cancellation, an outgoing signal level to

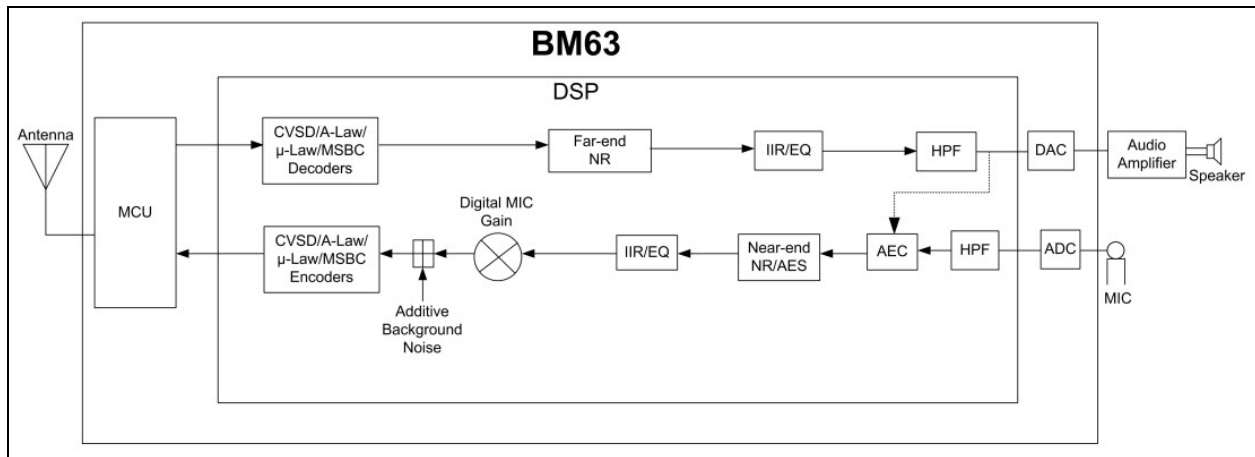
the speaker is monitored and adjusted to avoid saturation of speaker output or microphone input. Adaptive filtering is also applied to track the echo path impulse in response to provide echo free and full-duplex user experience.

The embedded noise reduction algorithm helps to extract clean speech signals from the noisy input captured by the microphones, and improves mutual understanding in communication.

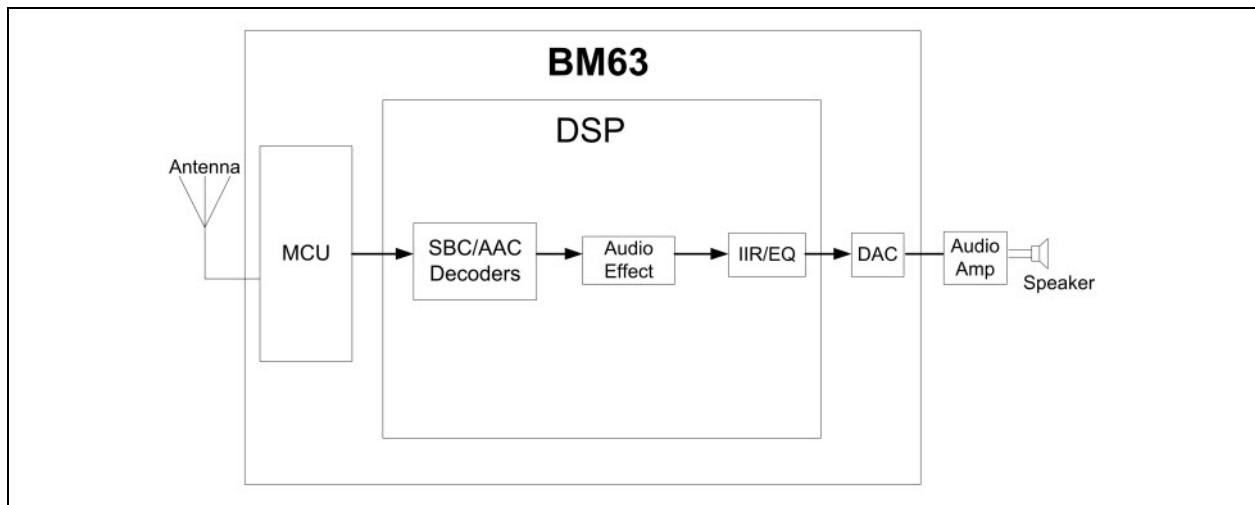
The advanced audio features, such as multi-band dynamic range control, parametric multi-band equalizer, audio widening and virtual bass are inbuilt. The audio effect algorithms improve the user's audio listening experience in terms of better audio quality after audio signal processing.

Figure 2-1 and Figure 2-2 illustrate the processing flow of speaker-phone applications for speech and audio signal processing.

**FIGURE 2-1: SPEECH SIGNAL PROCESSING**



**FIGURE 2-2: AUDIO SIGNAL PROCESSING**



# BM63

Users can configure DSP parameters using the DSP tool. For additional information on the DSP tool, refer to the “IS206X DSP Application Note”.

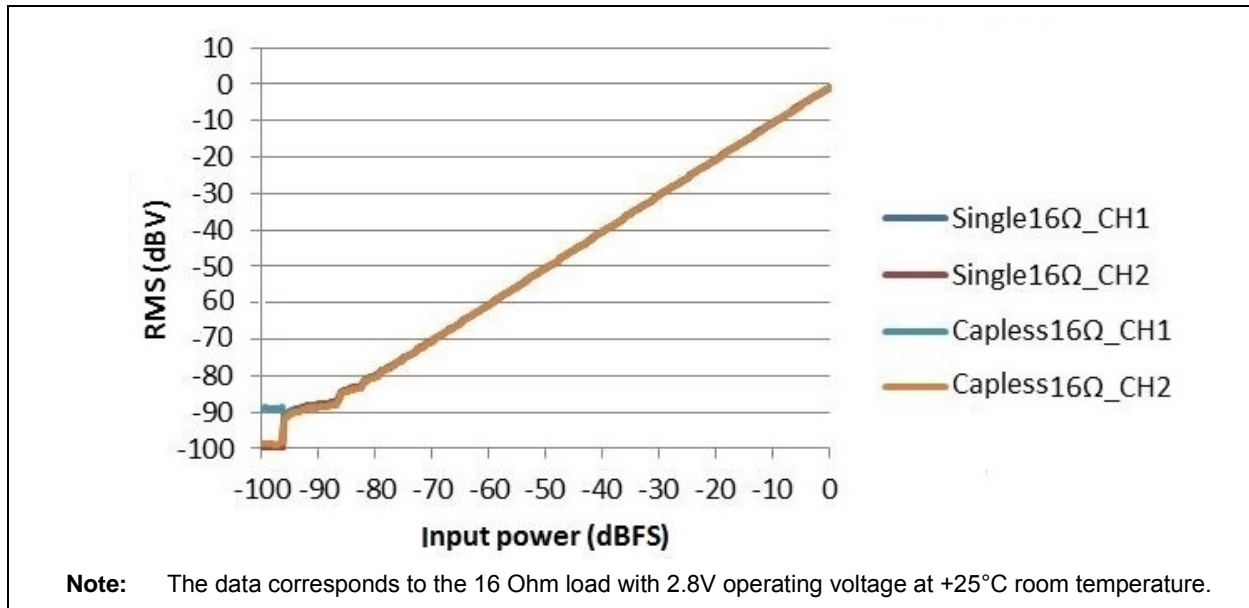
**Note:** The DSP tool and “IS206X DSP Application Note” document, are available for download from the Microchip web site at: [www.microchip.com/BM63](http://www.microchip.com/BM63).

## 2.2 Codec

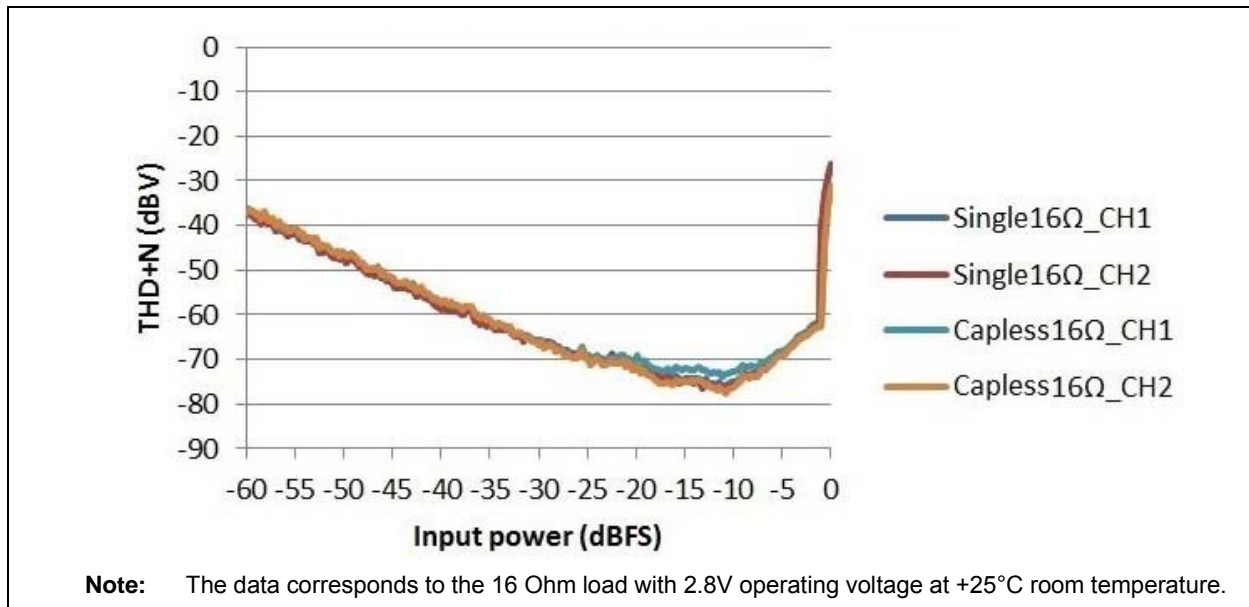
The built-in codec has a high signal-to-noise ratio (SNR) performance and it consists of an ADC, a DAC and an additional analog circuitry.

Figure 2-3 through Figure 2-6 illustrate the dynamic range and frequency response of the codec.

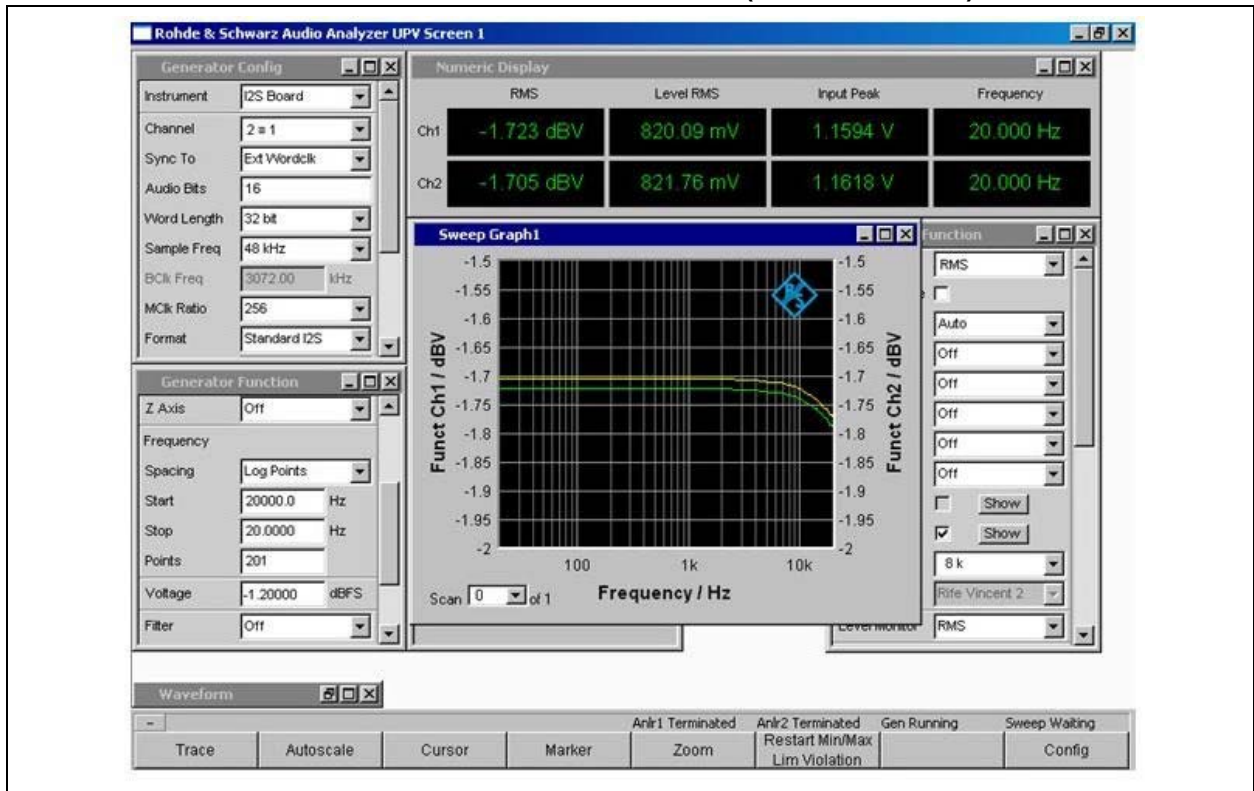
**FIGURE 2-3: CODEC DAC DYNAMIC RANGE**



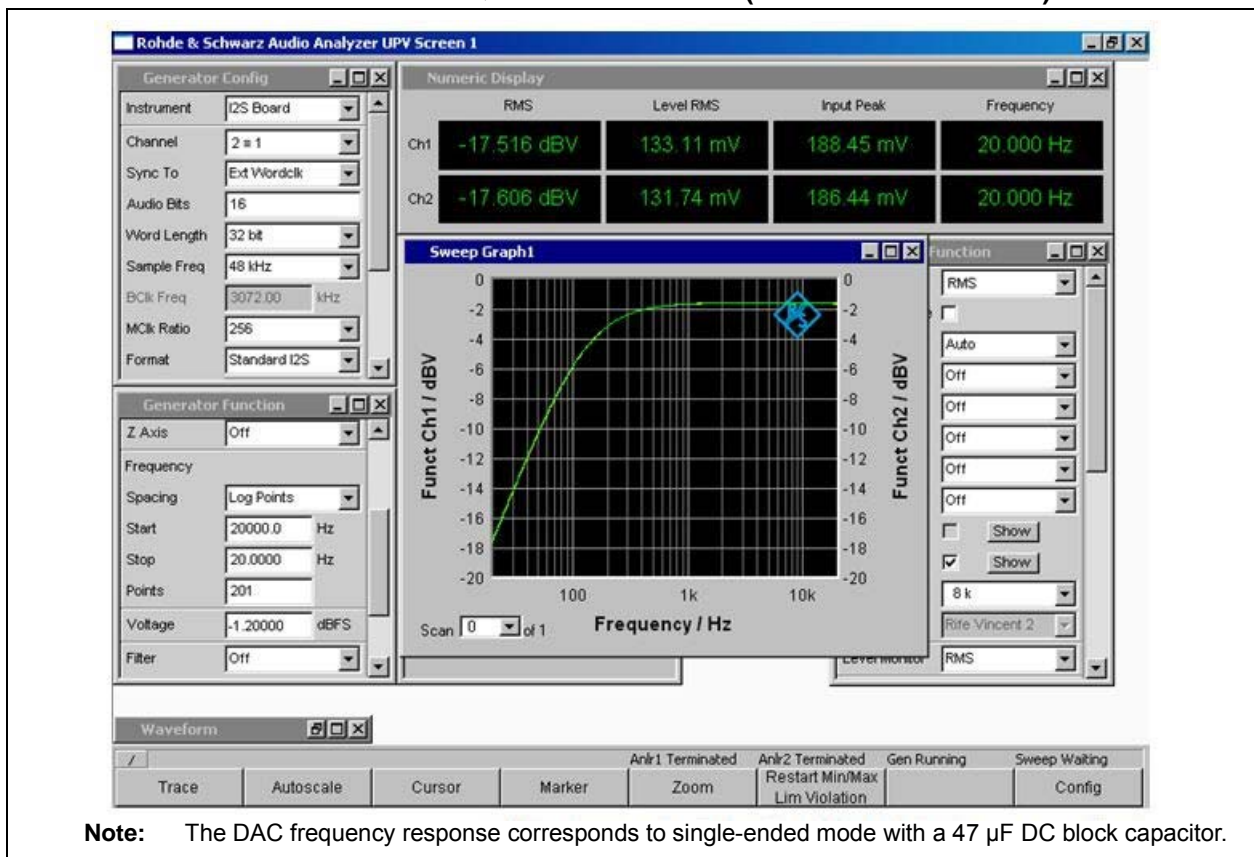
**FIGURE 2-4: CODEC DAC THD+N VERSUS INPUT POWER**



**FIGURE 2-5: CODEC DAC FREQUENCY RESPONSE (CAPLESS MODE)**



**FIGURE 2-6: CODEC DAC FREQUENCY RESPONSE (SINGLE-ENDED MODE)**



# BM63

## 2.3 Auxiliary Port

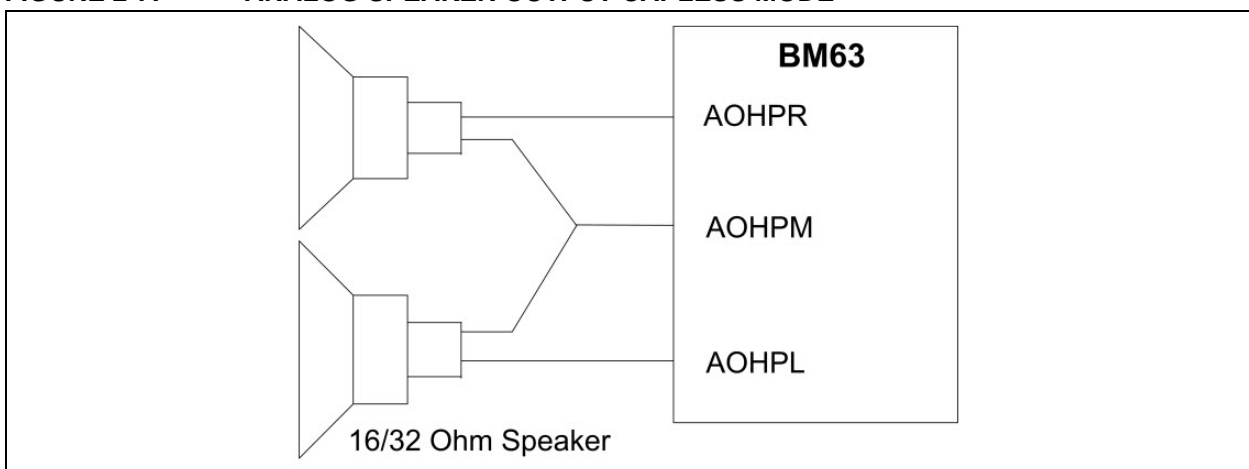
The BM63 module supports analog (line-in) signals from the external audio source. The analog (line-in) signal can be processed by the DSP to generate different sound effects (Multi-band dynamic range compression and audio widening), which can be configured by using the DSP tool.

## 2.4 Analog Speaker Output

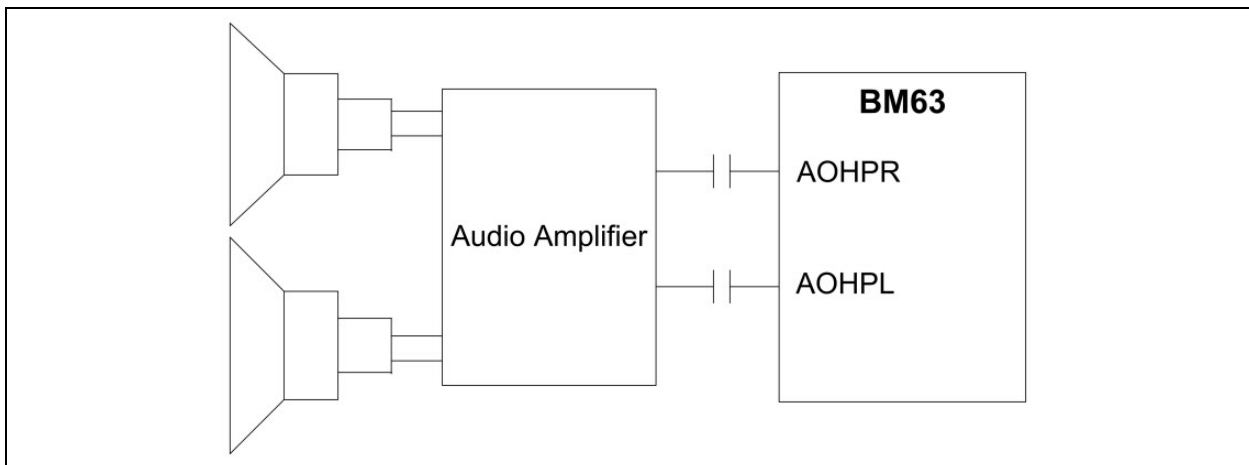
The BM63 module supports the following analog speaker output modes:

- Capless mode – Recommended for headphone applications in which capless output connection helps to save the BOM cost by avoiding a large DC blocking capacitor. [Figure 2-7](#) illustrates the analog speaker output capless mode
- Single-ended mode – Used for driving an external audio amplifier where a DC blocking capacitor is required. [Figure 2-8](#) illustrates the analog speaker output single-ended mode

**FIGURE 2-7: ANALOG SPEAKER OUTPUT CAPLESS MODE**



**FIGURE 2-8: ANALOG SPEAKER OUTPUT SINGLE-ENDED MODE**





## 3.0 TRANSCEIVER

The BM63 module is designed and optimized for Bluetooth 2.4 GHz system. It contains a complete radio frequency transmitter/receiver section. An internal synthesizer generates a stable clock for synchronizing with another device.

### 3.1 Transmitter

The internal power amplifier (PA) has a maximum output power of +4 dBm. This is applied for Class 2 or Class 3 radios without an external RF PA.

The transmitter performs the IQ conversion to minimize the frequency drift.

### 3.2 Receiver

The low-noise amplifier (LNA) operates with TR-combined mode for single port application. It can save a pin on the package without having an external Tx/Rx switch.

The ADC can sample the input analog signal and convert it into a digital signal for demodulator analysis. A channel filter has been integrated into receiver channel before the ADC, which is used to reduce the external component count and increase the anti-interference capability.

The image rejection filter is used to reject the image frequency for low-IF architecture. This filter for low-IF architecture is intended to reduce external Band Pass Filter (BPF) component for a super heterodyne architecture.

The Received Signal Strength Indicator (RSSI) signal feedback to the processor is used to control the RF output power to make a good trade-off for effective distance and current consumption.

### 3.3 Synthesizer

A synthesizer generates a clock for radio transceiver operation. There is a VCO inside, with a tunable internal LC tank that can reduce variation for components. A crystal oscillator with an internal digital trimming circuit provides a stable clock for the synthesizer.

### 3.4 Modem

For Bluetooth 1.2 specification and below, 1 Mbps was the standard data rate based on the Gaussian Frequency Shift Keying (GFSK) modulation scheme. This basic rate modem meets Basic Data Rate (BDR) requirements of Bluetooth 2.0 with Enhanced Data Rate (EDR) specifications.

For Bluetooth 2.0 and above specifications, EDR has been introduced to provide the data rates of 1/2/3 Mbps. For baseband, both BDR and EDR utilize the same 1 MHz symbol rate and 1.6 kHz slot rate. For BDR, symbol 1 represents 1-bit. However, each symbol in the payload part of EDR packets represents 2/3 bits. This is achieved by using two different modulations,  $\pi/4$  DQPSK and 8 DPSK.

### 3.5 Adaptive Frequency Hopping (AFH)

The BM63 module has an AFH function to avoid RF interference. It has an algorithm to check the nearby interference and to choose clear channel for transceiver Bluetooth signal.

# BM63

---

NOTES:

## 4.0 POWER MANAGEMENT UNIT

The on-chip Power Management Unit (PMU) has two main features: lithium-ion and lithium-polymer battery charger, and voltage regulator. A power switch is used to switch over the power source between the battery and an adapter. Also, the PMU provides current to drive three LEDs.

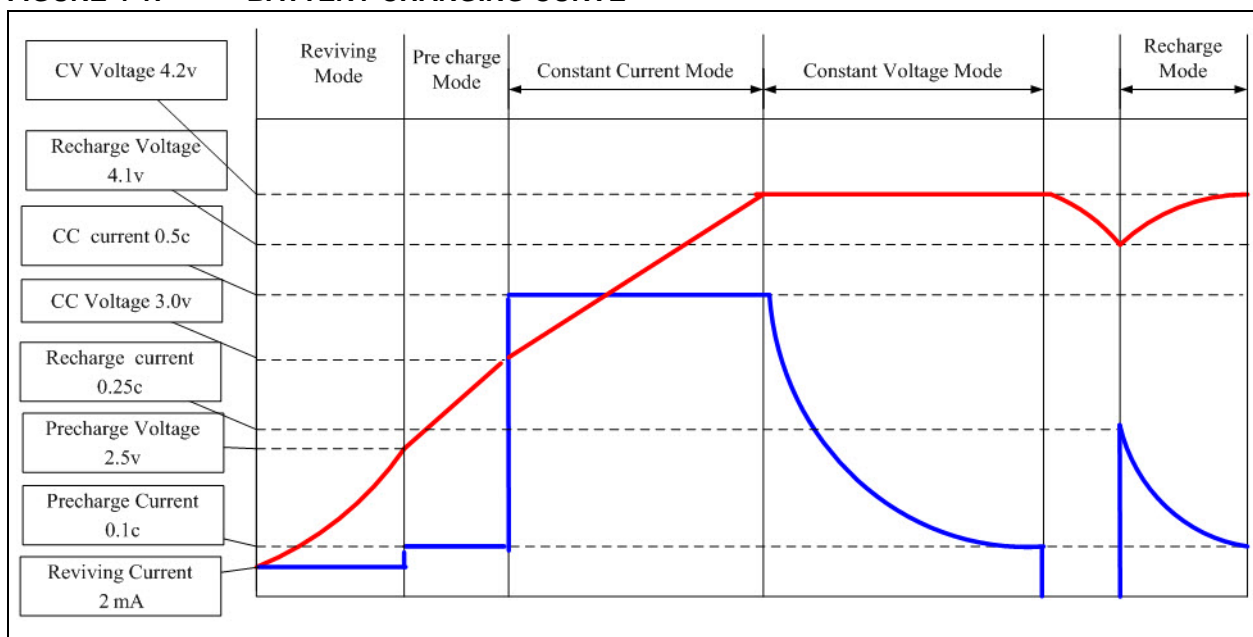
## 4.1 Charging a Battery

The BM63 module has a built-in battery charger which is optimized for lithium-ion and lithium-polymer batteries.

The battery charger includes a current sensor for charging control, user programmable current regulation and high accuracy voltage regulation.

The charging current parameters are configured by the UI tool. Reviving, pre-charging, constant current and constant voltage modes and re-charging functions are included. The maximum charging current is 350 mA. [Figure 4-1](#) illustrates the charging curve of a battery.

**FIGURE 4-1: BATTERY CHARGING CURVE**



## 4.2 Voltage Monitoring

A 10-bit successive approximation register ADC (SAR ADC) provides a dedicated channel for battery voltage level detection. The warning level can be programmed by using the UI tool. The ADC provides a granular resolution to enable the external MCU to take control over the charging process.

## 4.3 LED Driver

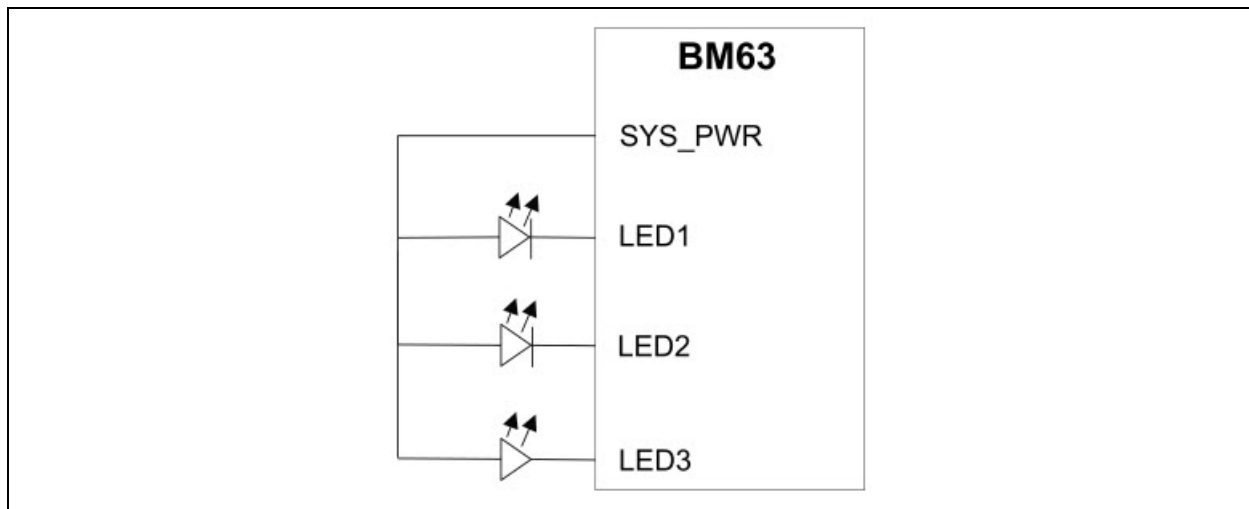
Three dedicated LED drivers control the LEDs. They provide enough sink current (16 step control and 0.35 mA for each step), thus LEDs can be connected with the BM63 module. The LED settings can be configured using the UI tool.

# BM63

---

Figure 4-2 illustrates the LED drivers in the BM63 module.

**FIGURE 4-2: LED DRIVER**



## 4.4 Under Voltage Protection

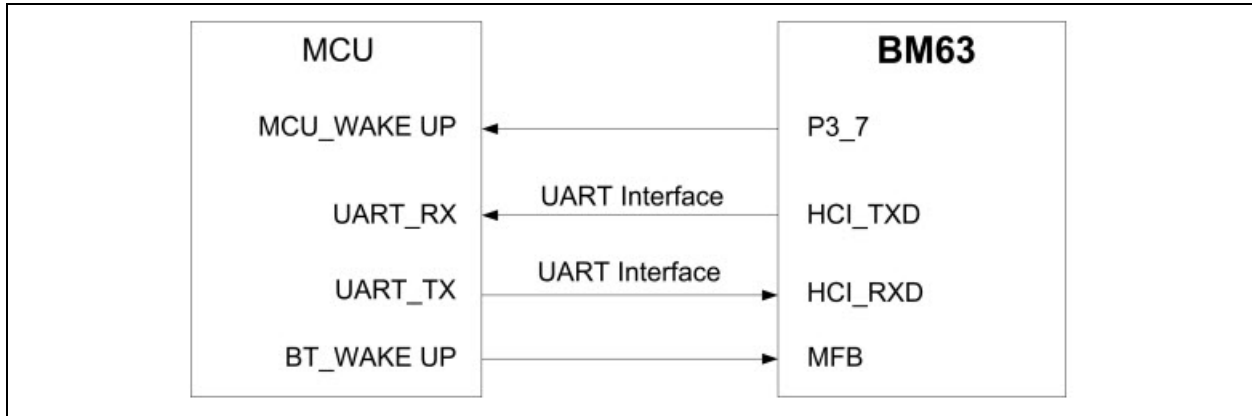
When the voltage of the SYS\_PWR pin drops below the voltage level of 2.9V, the system will shutdown automatically.

## 5.0 APPLICATION INFORMATION

### 5.1 Host MCU Interface

The BM63 module supports UART commands. The UART commands enable an external MCU to control the BM63 module. [Figure 5-1](#) illustrates the UART interface between the BM63 module and an external MCU.

**FIGURE 5-1: HOST MCU INTERFACE OVER UART**



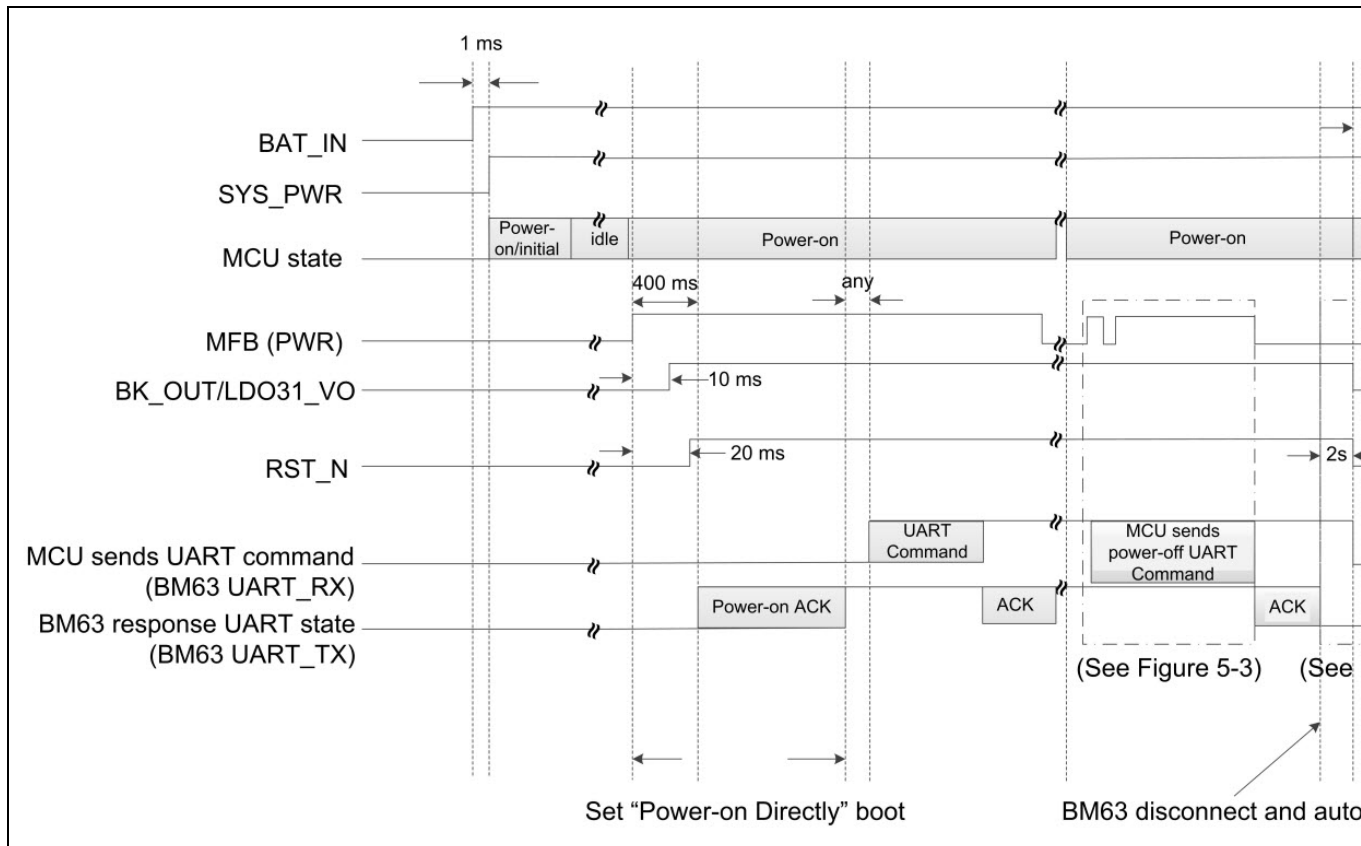
An external MCU can control the BM63 module over the UART interface and wakeup the module with the MFB and P3\_7 pins.

Refer to the “*UART\_CommandSet*” document for a list of functions the BM63 module supports and how to use the UI tool to configure the UART and UART Command Set tool.

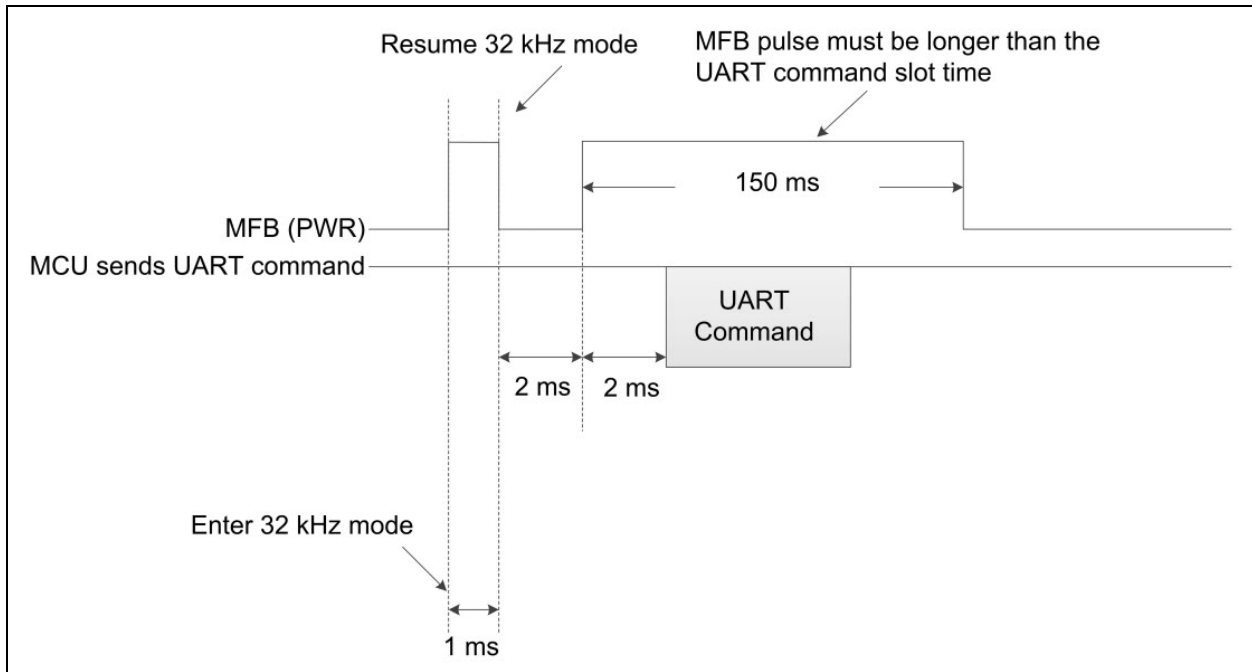
**Note:** The UART Command set tool (SPKCommandSetTool v160.xx) and “*UART\_CommandSet*” document are available for download from the Microchip web site at: [www.microchip.com/BM63](http://www.microchip.com/BM63).

Figure 5-2 through Figure 5-6 illustrate the timing sequences of various UART control signals.

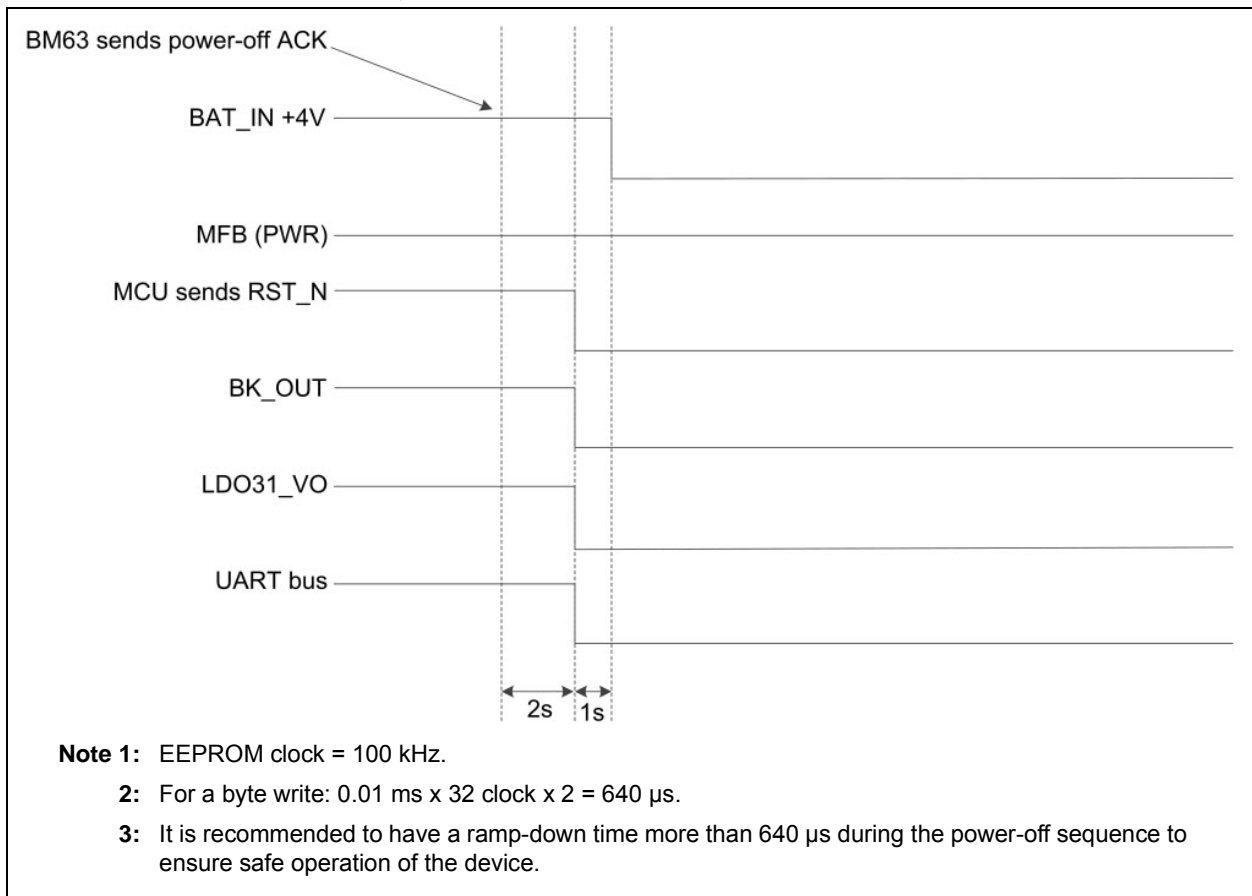
**FIGURE 5-2: POWER-ON/OFF SEQUENCE**



**FIGURE 5-3: TIMING SEQUENCE OF RX INDICATION AFTER POWER-ON STATE**

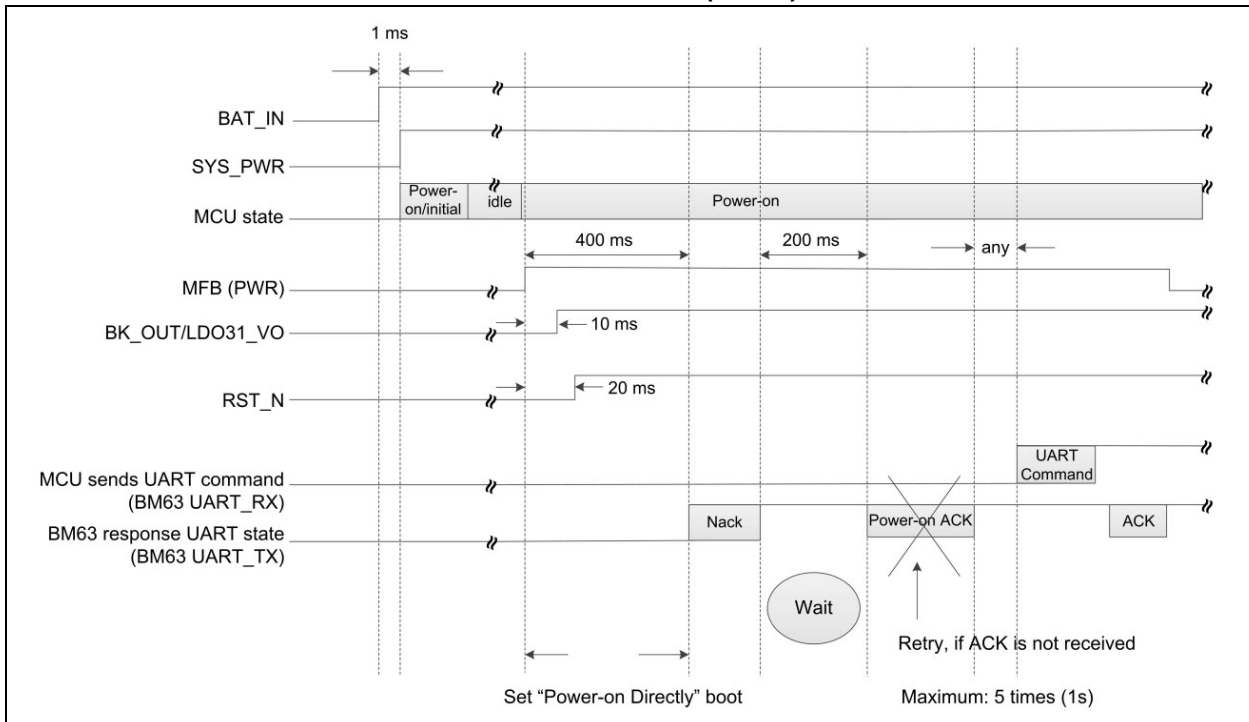


**FIGURE 5-4: TIMING SEQUENCE OF POWER-OFF STATE**

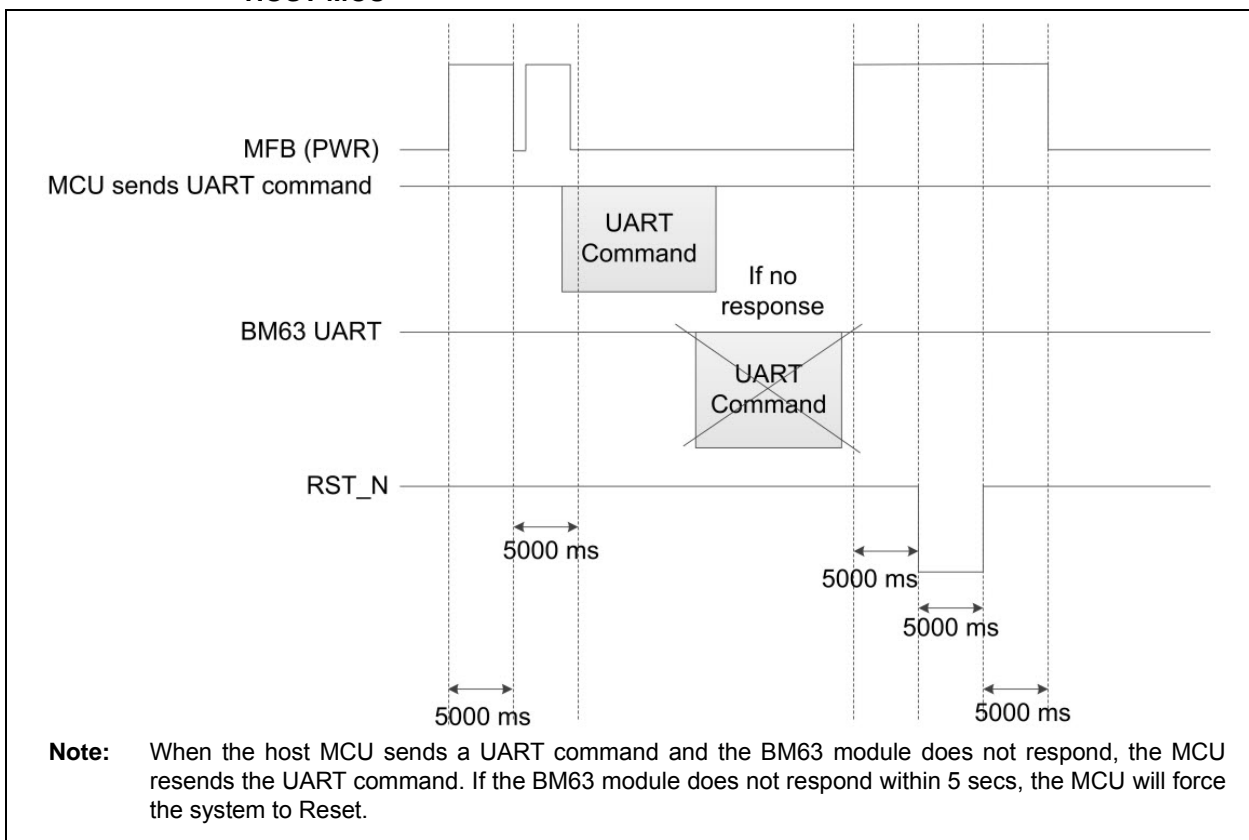


# BM63

**FIGURE 5-5: TIMING SEQUENCE OF POWER-ON (NACK)**



**FIGURE 5-6: RESET TIMING SEQUENCE IN CASE OF NO RESPONSE FROM MODULE TO HOST MCU**





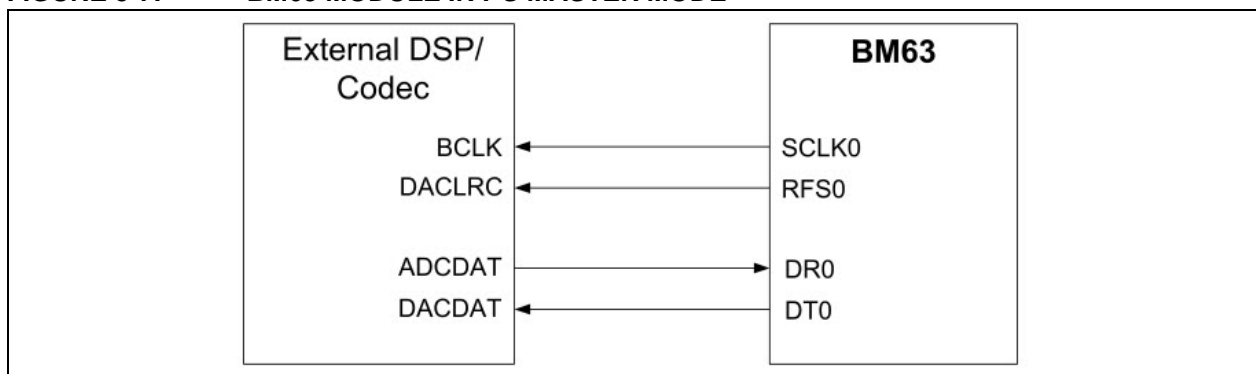
## 5.2 I<sup>2</sup>S Mode Application

The BM63 module provides an I<sup>2</sup>S digital audio output interface to connect with an external codec/DSP. It provides 8, 16, 44.1, 48, 88.2 and 96 kHz sampling rates for 16-bit and 24-bit data formats. The I<sup>2</sup>S setting can be configured using the UI and DSP tools.

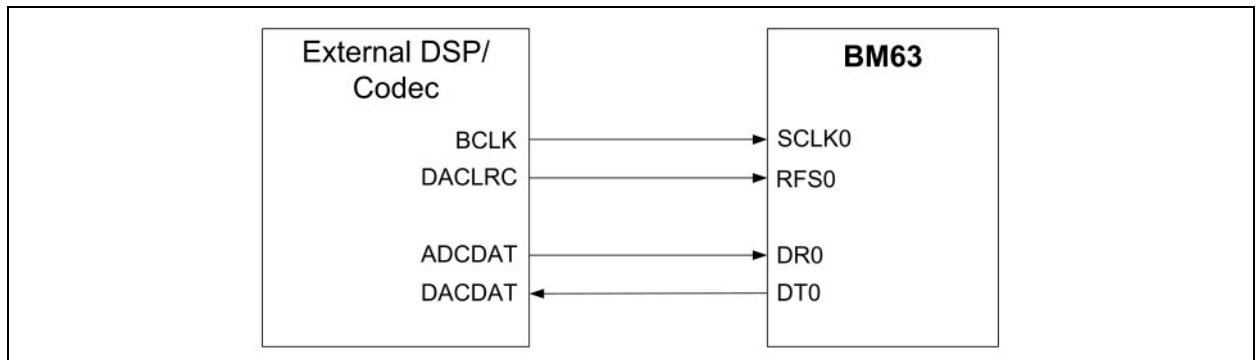
Figure 5-7 and Figure 5-8 illustrate the I<sup>2</sup>S signal connection between the BM63 module and an external DSP. Use the DSP tool to configure the BM63 module as a Master/Slave.

For additional information on timing specifications, refer to [8.2 “Timing specifications”](#).

**FIGURE 5-7: BM63 MODULE IN I<sup>2</sup>S MASTER MODE**



**FIGURE 5-8: BM63 MODULE IN I<sup>2</sup>S SLAVE MODE**



## 5.3 Reset

The BM63 module provides a watchdog timer (WDT) to reset the chip. It has an integrated Power-on Reset (POR) circuit that resets all circuits to a known Power-on state. This action can be driven by an external Reset signal which is used to control the device externally by forcing it into a POR state. The RST\_N signal input is active-low and no connection is required in most of the applications.

# BM63

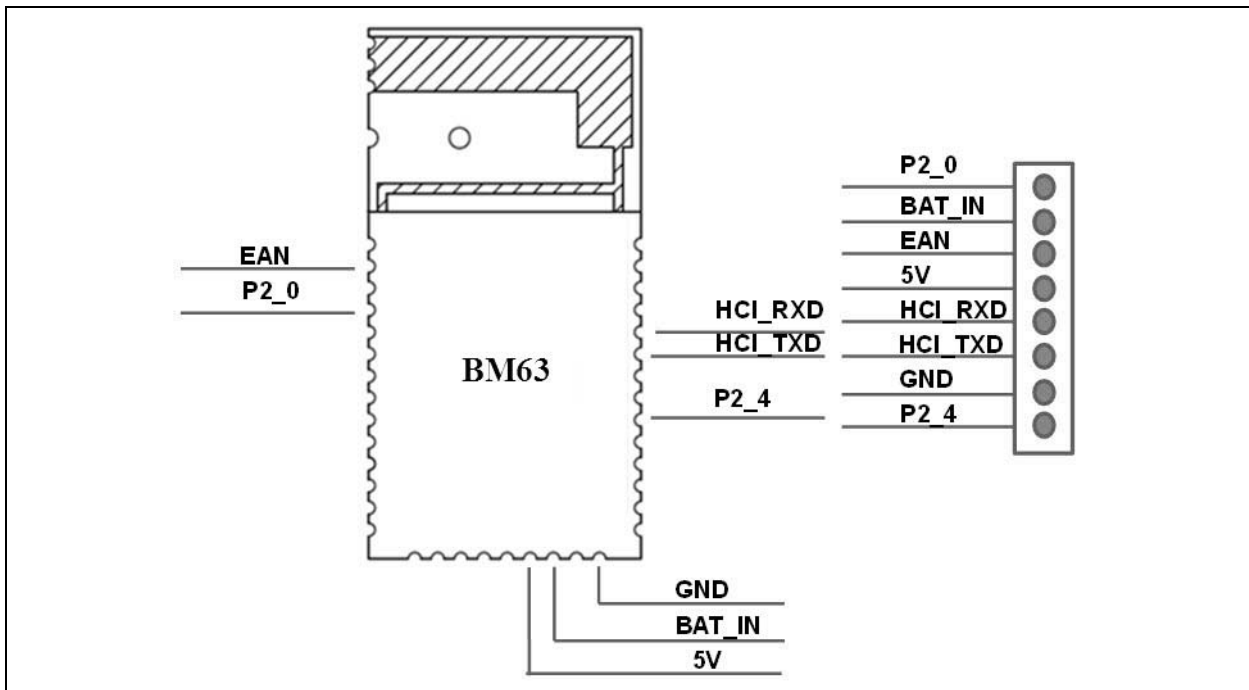
## 5.4 External Configuration and Programming

The BM63 module can be configured by using an external configuration tool (EEPROM tool) and the firmware is programmed by using a programming tool (Flash tool).

**Note:** The EEPROM and Flash tools are available for download from the Microchip web site at: [www.microchip.com/BM63](http://www.microchip.com/BM63).

Figure 5-9 illustrates the configuration and firmware programming interface on the BM63 module. It is recommended to include a header pin on the main PCB for development.

**FIGURE 5-9: EXTERNAL PROGRAMMING HEADER CONNECTIONS**



Configuration and firmware programming modes are entered according to the system configuration I/O pins. The P2\_0, P2\_4 and EAN pins have internal pull up.

Table 5-1 provides the system configuration settings.

**TABLE 5-1: SYSTEM CONFIGURATION I/O PINSETTINGS**

Pins			Operating Mode
P2_0	P2_4	EAN	
High	High	Low (Flash), High (ROM)	APP mode (Normal operation)
Low	High	Low (Flash), High (ROM)	Test mode (Write EEPROM)
Low	Low	High	Write Flash

### 5.5 Reference Circuit

Figure 5-10 through Figure 5-14 illustrate the BM63 module reference circuit for a stereo headset applications.

**FIGURE 5-10: BM63 REFERENCE CIRCUIT FOR STEREO HEADSET APPLICATIONS**

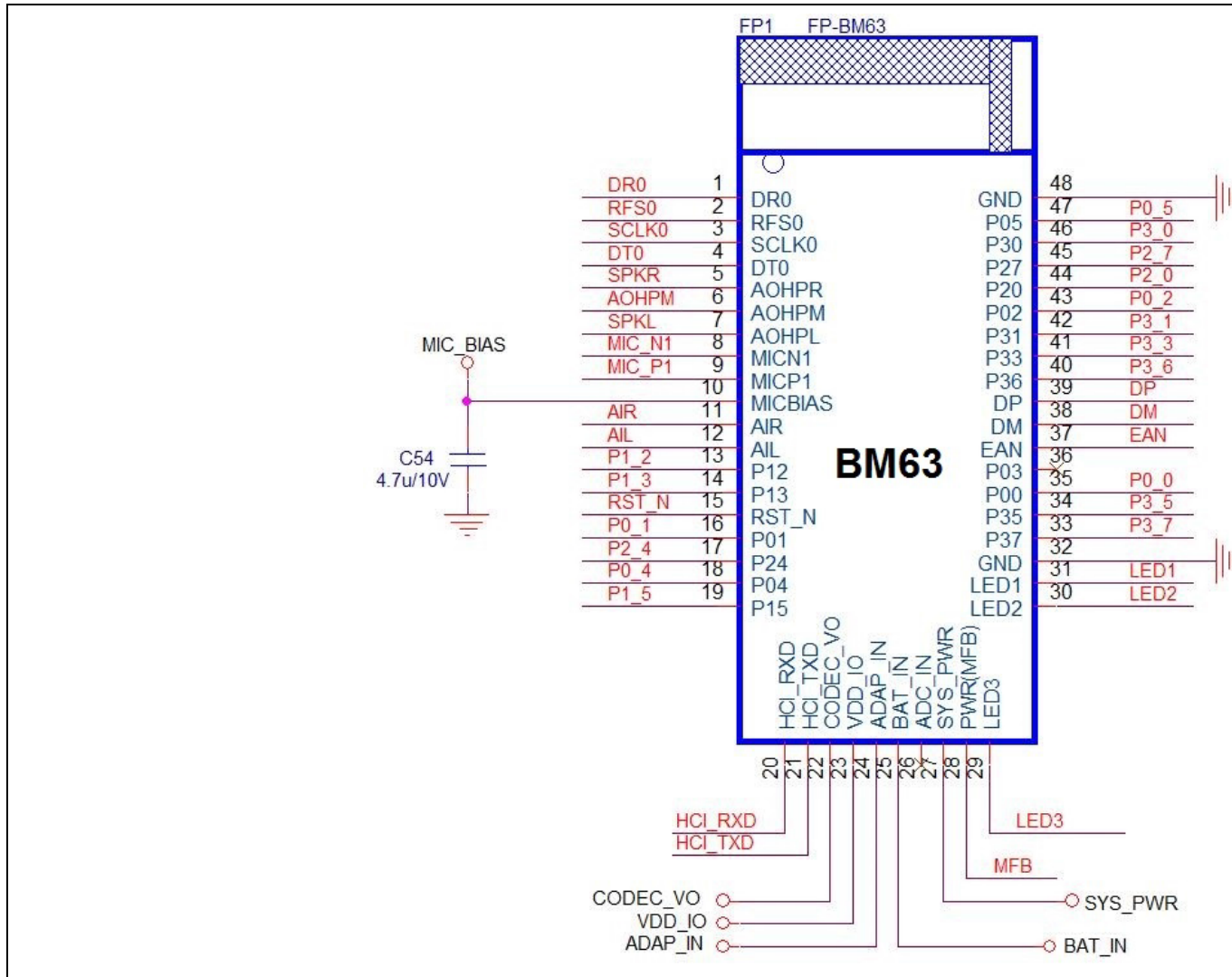


FIGURE 5-11: BM63 REFERENCE CIRCUIT FOR STEREO HEADSET APPLICATIONS

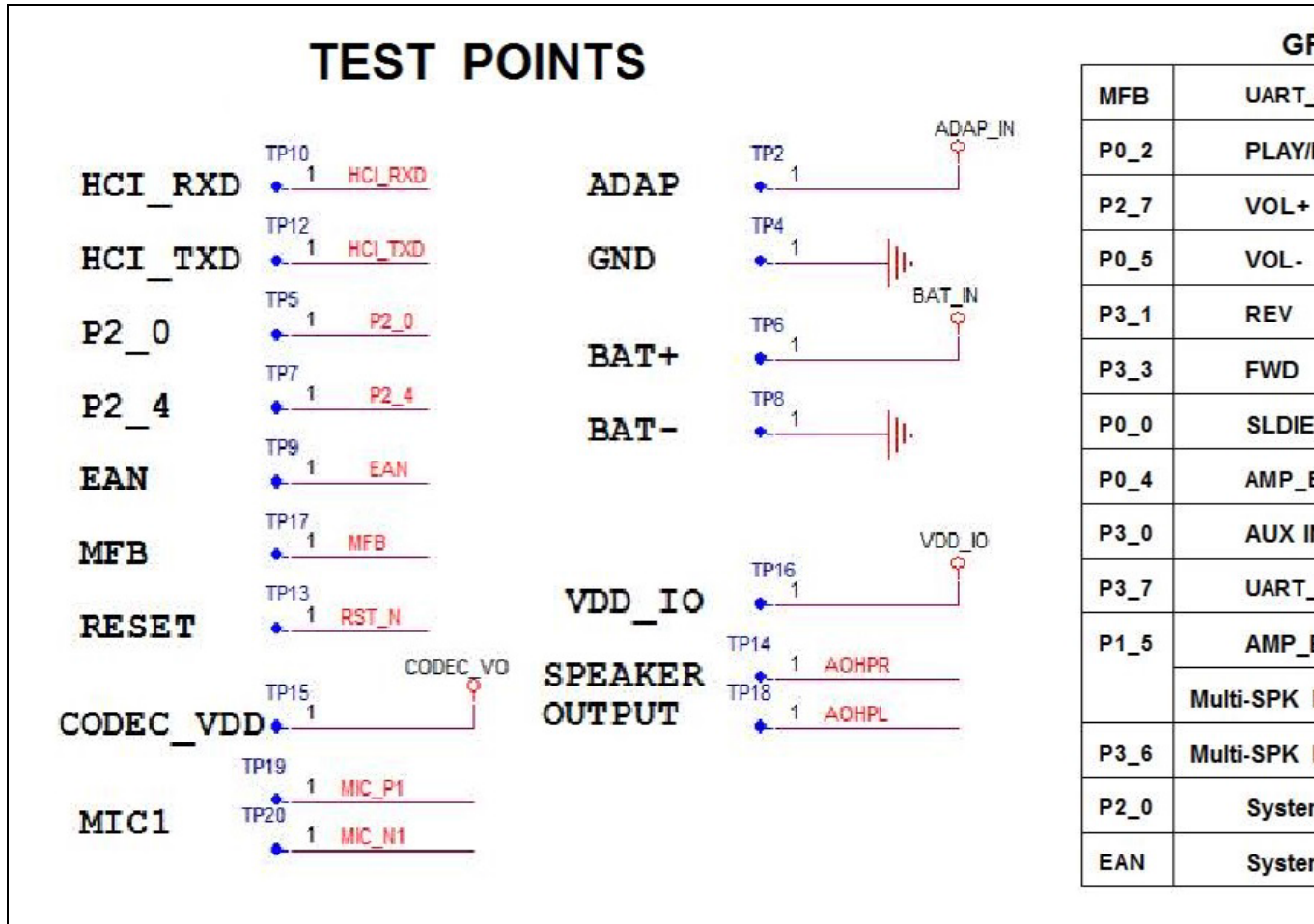


FIGURE 5-12: BM63 REFERENCE CIRCUIT FOR STEREO HEADSET APPLICATIONS

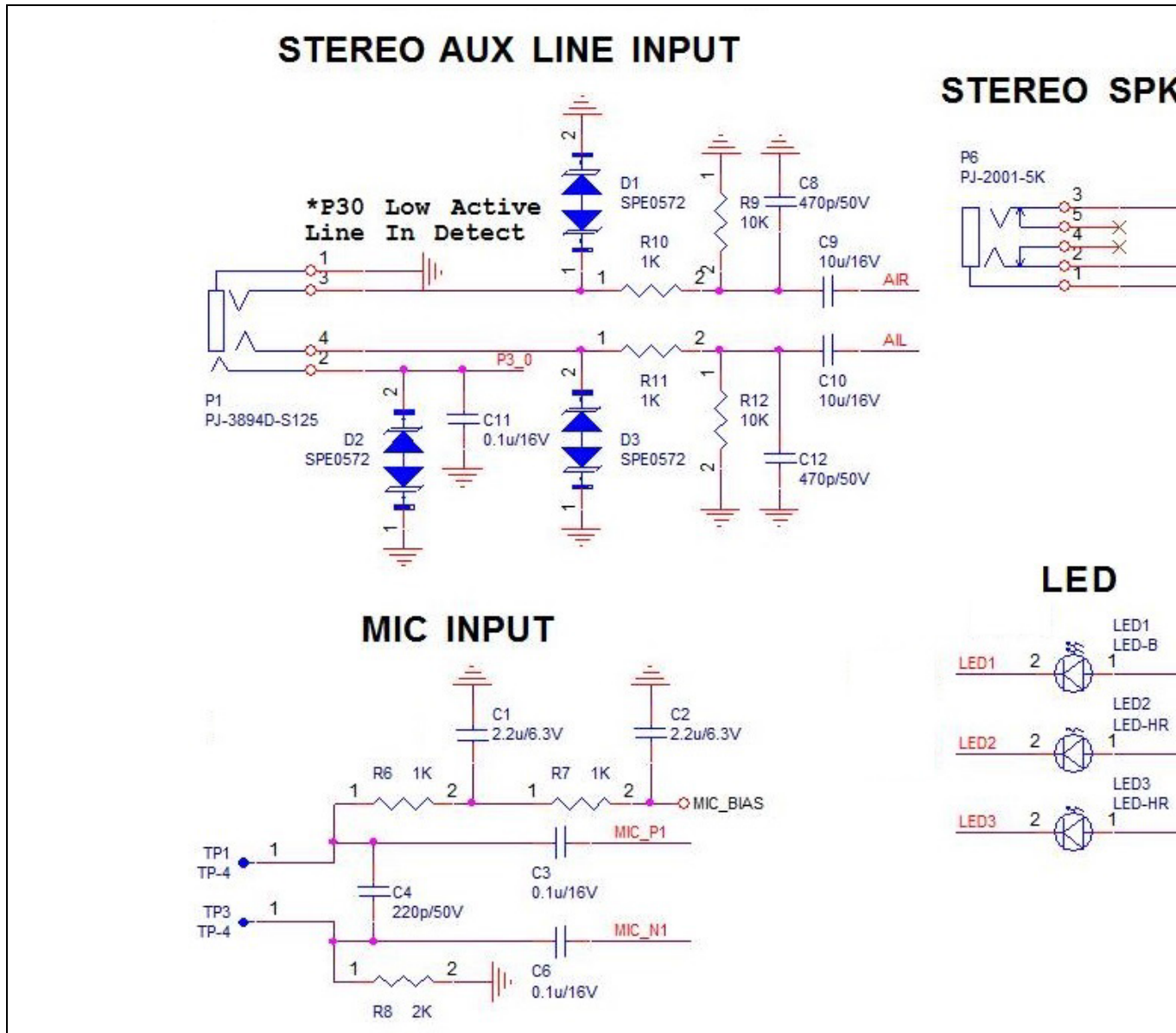
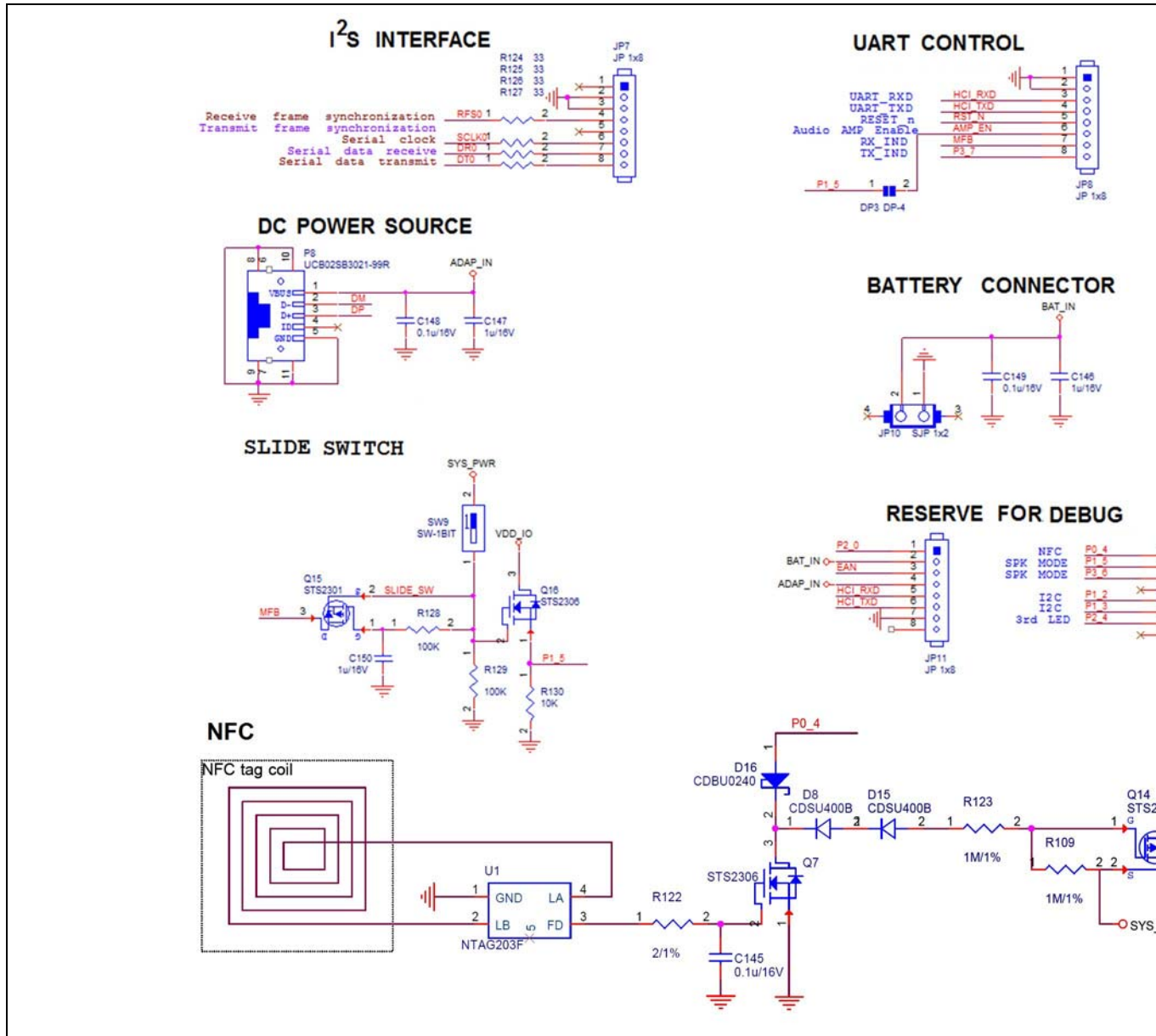
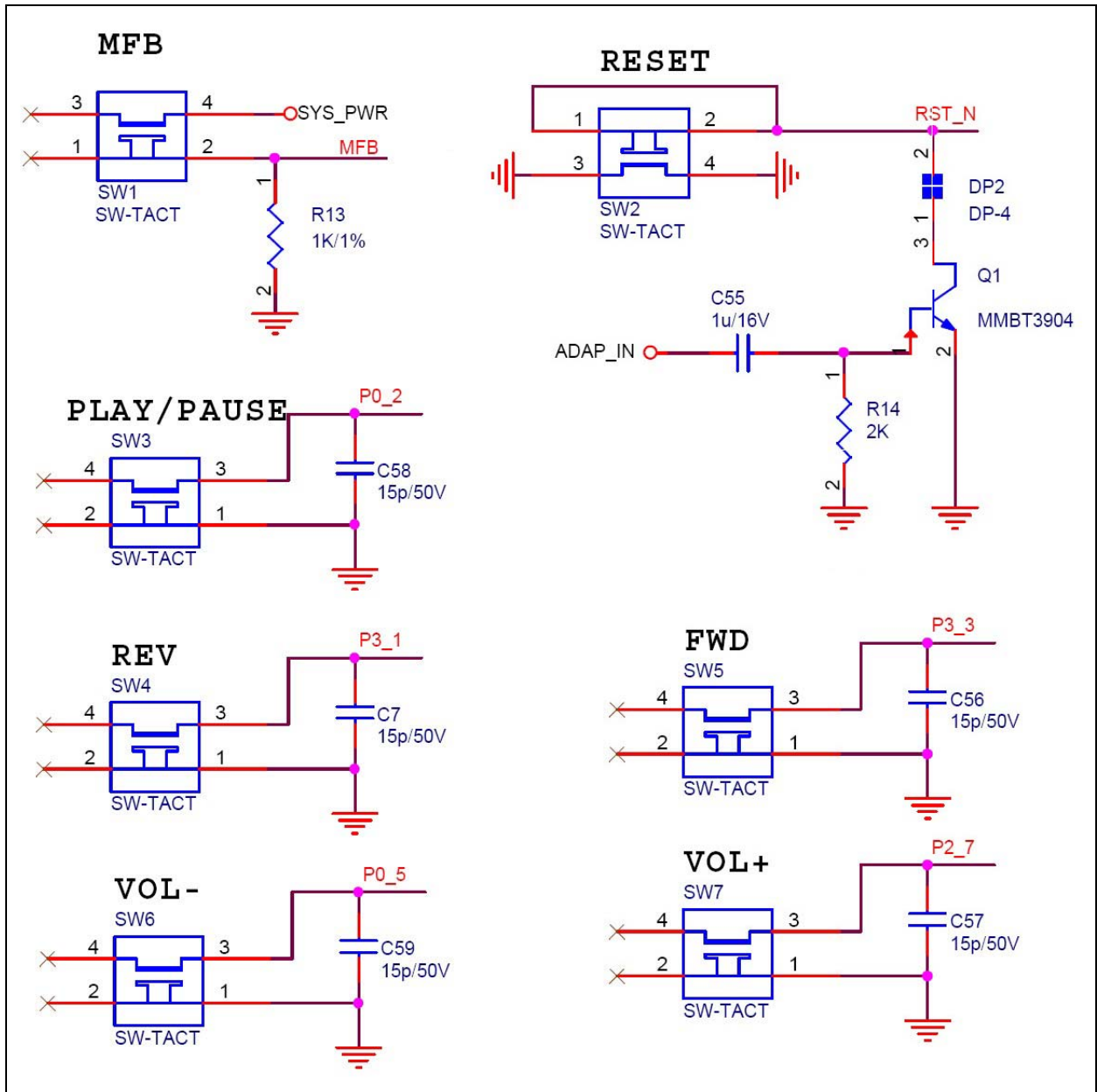


FIGURE 5-13: BM63 REFERENCE CIRCUIT FOR STEREO HEADSET APPLICATIONS



**FIGURE 5-14: BM63 REFERENCE CIRCUIT FOR STEREO HEADSET APPLICATIONS**



# BM63

---

NOTES:

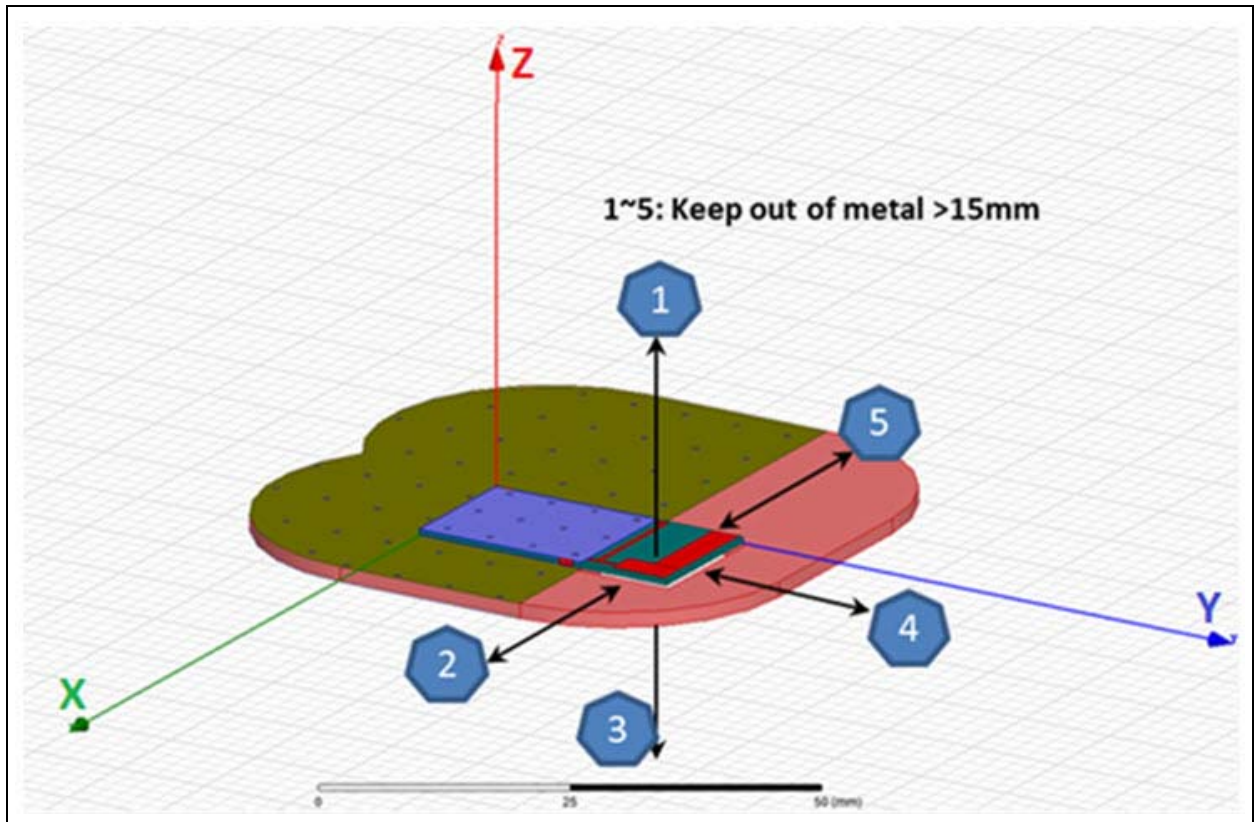


## 6.0 PRINTED ANTENNA INFORMATION

### 6.1 Antenna Radiation Pattern

The BM63 module is integrated with one PCB printed antenna, see [Figure 6-1](#).

**FIGURE 6-1: RECOMMENDED KEEPOUT AREA FOR PCB ANTENNA**



# BM63

Figure 6-2 illustrates the 3D radiation pattern of the PCB printed antenna at 2441 MHz.

**FIGURE 6-2: PCB ANTENNA 3D RADIATION PATTERN AT 2441 MHZ**

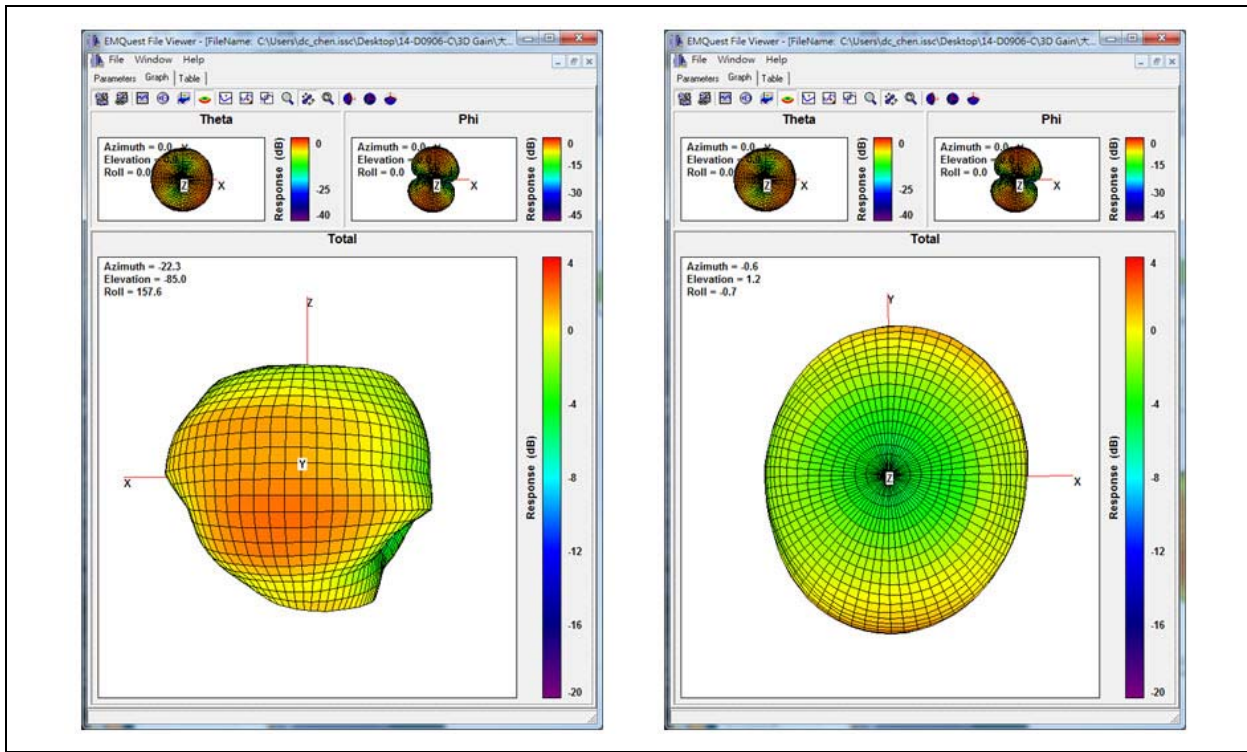


Table 6-1 provides the PCB Antenna characteristics of BM63 module.

**TABLE 6-1: BM63 PCB ANTENNA CHARACTERISTICS**

Parameter	Values
Frequency	2400 MHz to 2480 MHz
Peak Gain	1.927 dBi
Efficiency	73.41%

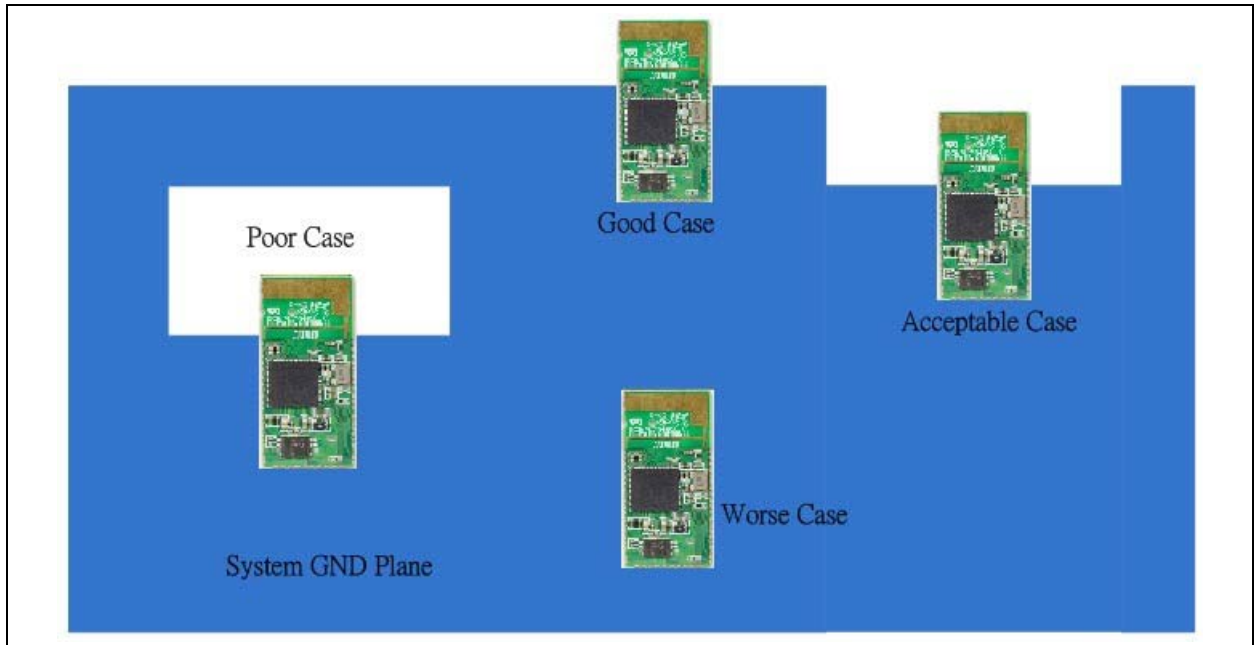
## 6.2 Module Placement Guidelines

For Bluetooth-enabled products, the antenna placement affects the overall performance of the system. The antenna requires free space to radiate RF signals and it must not be surrounded by the ground plane. Microchip recommends that the area underneath the antenna on the host PCB must not contain copper on the top, inner, or bottom layers, as illustrated in Figure 6-1.

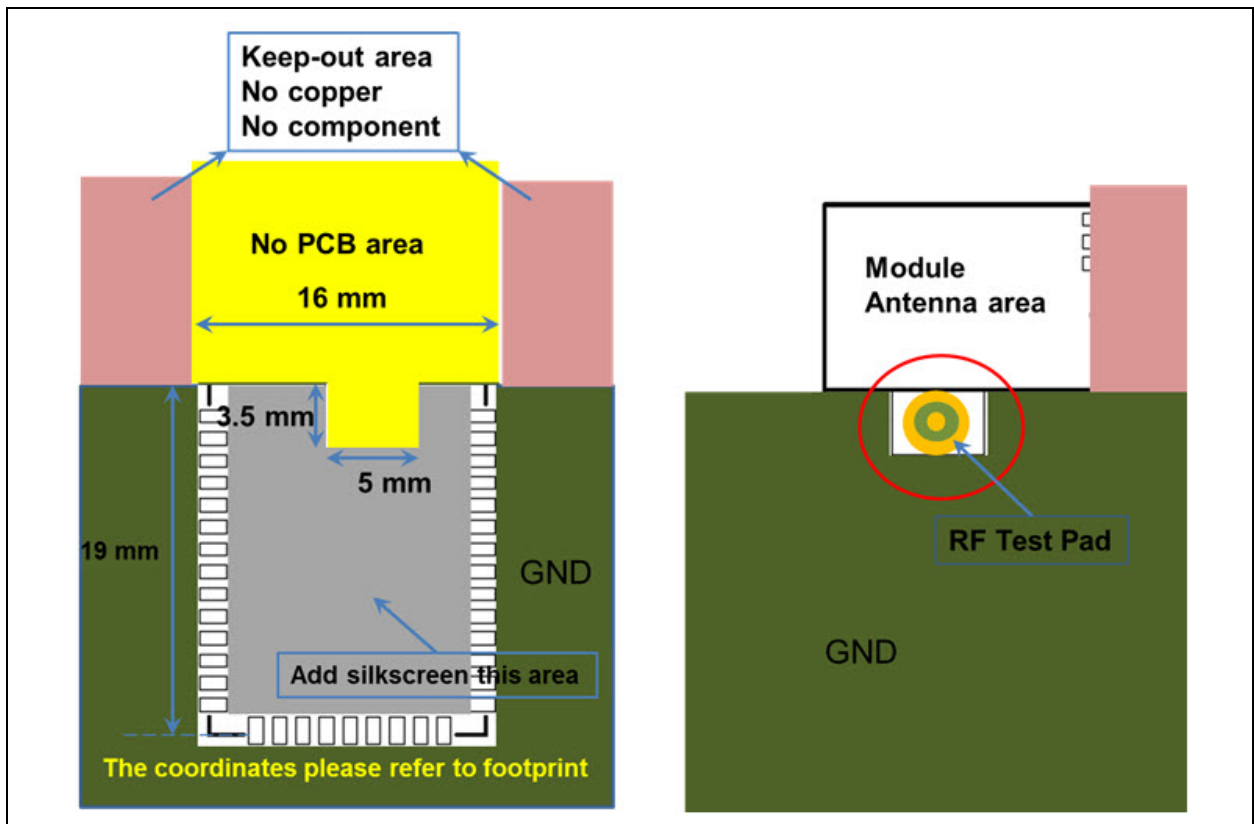
A low-impedance ground plane will ensure the best radio performance (best range, lowest noise). The ground plane can be extended beyond the minimum recommendation, as required for the main PCB EMC noise reduction, as required for the main PCB EMC noise reduction. For the best range performance, keep all external metal at least 15 mm away from the on-board PCB trace antenna.

Figure 6-3 and Figure 6-4 illustrate the examples of good and poor placement of the BM63 module on a host board with GND plane.

**FIGURE 6-3: BM63 MODULE PLACEMENT GUIDELINES**



**FIGURE 6-4: GND PLANE ON MAIN APPLICATION BOARD**



# BM63

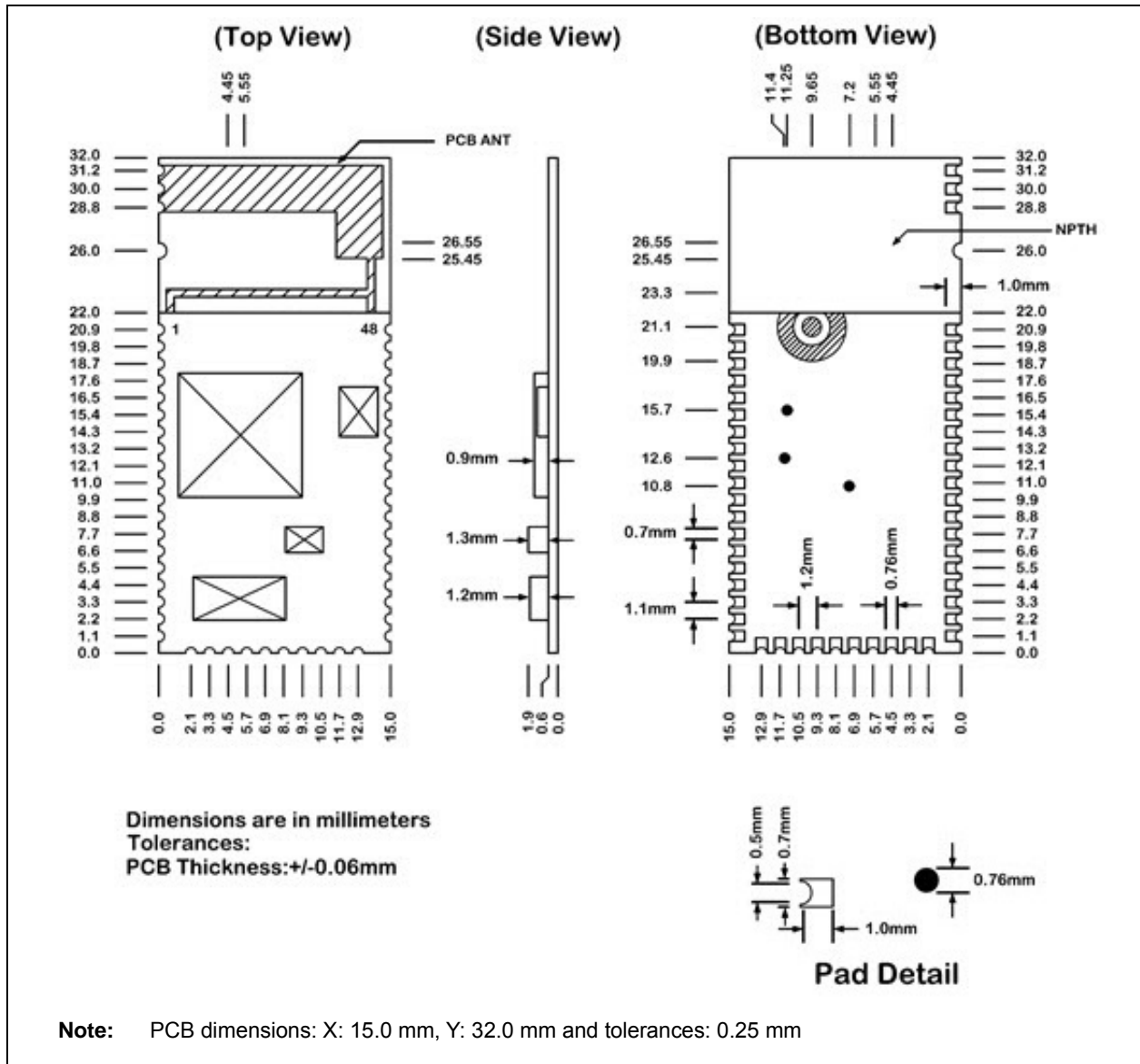
---

NOTES:

## 7.0 PHYSICAL DIMENSIONS

Figure 7-1 illustrates the PCB dimensions of the BM63 module.

FIGURE 7-1: BM63 MODULE PCB DIMENSIONS





---

---

## 8.0 ELECTRICAL CHARACTERISTICS

This section provides an overview of the BM63 module electrical characteristics. Additional information will be provided in future revisions of this document as it becomes available.

Absolute maximum ratings for the BM63 module are listed below. Exposure to these maximum rating conditions for extended periods may affect device reliability. Functional operation of the device at these or any other conditions, above the parameters indicated in the operation listings of this specification, is not implied.

### 8.1 Absolute Maximum Ratings

Ambient temperature under bias.....	-20°C to +70°C
Storage temperature .....	-40°C to +125°C
Voltage on VDD with respect to Vss .....	-0.3V to +3.6V
Maximum output current sink by any I/O pin.....	12 mA
Maximum output current sourced by any I/O pin.....	12 mA

<p><b>Note:</b> Stresses listed under “<b>Absolute Maximum Ratings</b>” may cause permanent damage to the device. This is a stress rating only. The functional operation of the device at those or any other conditions and those indicated in the operation listings of this specification, is not implied. Exposure to maximum rating conditions for extended periods may affect device reliability.</p>
--

# BM63

Table 8-1 through Table 8-10 provide the recommended operating conditions and the electrical specifications of the BM63 module.

**TABLE 8-1: RECOMMENDED OPERATING CONDITION**

Symbol	Parameter	Min.	Typ.	Max.	Unit
BAT_IN	Input voltage for battery	3.2	3.8	4.2	V
ADAP_IN	Input voltage for adapter	4.5	5	5.5	V
TOPERATION	Operation temperature	-20	+25	+70	°C

**Note:** The absolute and recommended operating condition tables reflect a typical voltage usage for the device.

**TABLE 8-2: I/O AND RESET LEVEL**

Parameter	Min.	Typ.	Max.	Unit
I/O Supply Voltage (VDD_IO)	3.0	3.3	3.6	V
I/O Voltage Levels				
V <sub>IL</sub> input logic levels low	0	–	0.8	V
V <sub>IH</sub> input logic levels high	2.0	–	3.6	V
V <sub>OL</sub> output logic levels low	–	–	0.4	V
V <sub>OH</sub> output logic levels high	2.4	–	–	V
RST_N				
Threshold voltage	–	0.8	–	V

**Note:** These parameters are characterized, but not tested in manufacturing.

**TABLE 8-3: BATTERY CHARGER**

Parameter	Min.	Typ.	Max.	Unit	
ADAP_IN Input Voltage	4.5	5.0	5.5	V	
Supply current to charger only	–	3	4.5	mA	
Maximum Battery Fast Charge Current	Headroom > 0.7V (ADAP_IN = 5V)	–	350	–	mA
	Headroom = 0.3V to 0.7V (ADAP_IN = 4.5V)	–	175 <sup>(2)</sup>	–	mA
Trickle Charge Voltage Threshold	–	3	–	V	
Battery Charge Termination Current, (% of Fast Charge Current)	–	10	–	%	

**Note 1:** Headroom = V<sub>ADAP\_IN</sub> – V<sub>BAT</sub>

**2:** When V<sub>ADAP\_IN</sub> – V<sub>BAT</sub> > 2V, the maximum fast charge current is 175 mA for thermal protection.

**3:** These parameters are characterized, but not tested in manufacturing.



**TABLE 8-4: LED DRIVER**

Parameter	Min.	Typ.	Max.	Unit
Open-drain Voltage	–	–	3.6	V
Programmable Current Range	0	–	5.25	mA
Intensity Control	–	16	–	step
Current Step	–	0.35	–	mA
Power Down Open-drain Current	–	–	1	μA
Shutdown Current	–	–	1	μA

**Note 1:** Test condition: BK\_OUT = 1.8V with +25°C temperature.

**2:** These parameters are characterized, but not tested in manufacturing.

**TABLE 8-5: AUDIO CODEC ANALOG TO DIGITAL CONVERTER**

T = 25°C, V<sub>DD</sub> = 2.8V, 1 kHz sine wave input, Bandwidth = 20 Hz to 20 kHz

Parameter (Condition)	Min.	Typ.	Max.	Unit
Resolution	–	–	16	Bit
Output Sample Rate	8	–	48	kHz
Signal to Noise Ratio ( <b>Note 1</b> ) (SNR at MIC or Line-in mode)	–	92	–	dB
Digital Gain	-54	–	4.85	dB
Digital Gain Resolution	–	2 to 6	–	dB
MIC Boost Gain	–	20	–	dB
Analog Gain	–	–	60	dB
Analog Gain Resolution	–	2.0	–	dB
Input full-scale at maximum gain (differential)	–	4	–	mV/rms
Input full-scale at minimum gain (differential)	–	800	–	mV/rms
3 dB bandwidth	–	20	–	kHz
Microphone mode (input impedance)	–	24	–	kOhm
THD+N (microphone input) at 30 mV/rms input	–	0.02	–	%

**Note 1:**  $f_{IN} = 1$  kHz, B/W = 20 Hz to 20 kHz, A-weighted, THD+N < 1%, 150 mV<sub>PP</sub> input.

**2:** These parameters are characterized, but not tested in manufacturing.

# BM63

**TABLE 8-6: AUDIO CODEC DIGITAL TO ANALOG CONVERTER**

T = 25°C, V<sub>DD</sub> = 2.8V, 1 kHz sine wave input, Bandwidth = 20 Hz to 20 kHz

Parameter (Condition)	Min.	Typ.	Max.	Unit	
Over-sampling rate	–	128	–	f <sub>s</sub>	
Resolution	16	–	20	Bit	
Output Sample Rate	8	–	48	kHz	
Signal to Noise Ratio ( <b>Note 1</b> ) (SNR at capless mode) for 48 kHz	–	98	–	dB	
Signal to Noise Ratio ( <b>Note 1</b> ) (SNR at single-ended mode) for 48 kHz	–	98	–	dB	
Digital Gain	-54	–	4.85	dB	
Digital Gain Resolution	–	2 to 6	–	dB	
Analog Gain	-28	–	3	dB	
Analog Gain Resolution	–	1	–	dB	
Output Voltage Full-scale Swing (AV <sub>DD</sub> = 2.8V)	495	742.5	–	mV/rms	
Maximum Output Power (16 Ohm load)	–	34.5	–	mW	
Maximum Output Power (32 Ohm load)	–	17.2	–	mW	
Allowed Load	Resistive	–	16	O.C.	Ohm
	Capacitive	–	–	500	pF
THD+N (16 Ohm load) ( <b>Note 2</b> )	–	0.05	–	%	
Signal to Noise Ratio (SNR at 16 Ohm load) ( <b>Note 3</b> )	–	98	–	dB	

**Note 1:** f<sub>IN</sub> = 1 kHz, B/W = 20 Hz to 20 kHz, A-weighted, THD+N < 0.01%, 0 dBFS signal, Load = 100 kOhm

**2:** f<sub>IN</sub> = 1 kHz, B/W = 20 Hz to 20 kHz, A-weighted, -1 dBFS signal, Load = 16 Ohm

**3:** f<sub>IN</sub> = 1 kHz, B/W = 20 Hz to 20 kHz, A-weighted, THD+N < 0.05%, 0 dBFS signal, Load = 16 Ohm

**4:** These parameters are characterized but not tested in manufacturing.

**TABLE 8-7: TRANSMITTER SECTION FOR BDR AND EDR**

Parameter	Min.	Typ.	Max.	Bluetooth specification	Unit
RF transmit power	–	2	–	-6 to 4	dBm
EDR/BDR Relative transmit power	-4	-1.8	1	-4 to 1	dB

**Note 1:** The RF Tx power is modulation value.

**2:** The RF Transmit power is calibrated during the production by using the MP tool software and MT8852 Bluetooth Test equipment.

**3:** Test condition: VCC<sub>RF</sub> = 1.28V, temperature +25°C.

**TABLE 8-8: RECEIVER SECTION FOR BDR AND EDR**

	Modulation	Min.	Typ.	Max.	Bluetooth specification	Unit
Sensitivity at 0.1% BER	GFSK	–	-89	–	≤-70	dBm
Sensitivity at 0.01% BER	π/4 DQPSK	–	-90	–	≤-70	dBm
	8 DPSK	–	-83	–	≤-70	dBm

**Note 1:** Test condition: VCC\_RF = 1.28V with temperature +25°C.

**2:** These parameters are characterized, but not tested in manufacturing.

**TABLE 8-9: BM63 SYSTEM CURRENT CONSUMPTION**

System Status	Typ. <sup>(1)</sup>	Max.	Unit
System-Off mode	–	10	μA
Stop advertising (Samsung S5 (SM-G900I)/Android™ 4.4.2)			
Standby mode	0.57	–	mA
Link mode	0.5	–	mA
ESCO link	15.1	–	mA
A2DP link	14.3	–	mA
Stop advertising (iPhone® 6/iOS 8.4)			
Standby mode	0.6	–	mA
Link mode	0.6	–	mA
SCO link	15.3	–	mA
A2DP link	15.4	–	mA

**Note 1:** The measurement data corresponds to Firmware v1.0.

**2:** Mode definition:

Standby mode: Power-on without Bluetooth link;

Link mode: With Bluetooth link in Low-power mode.

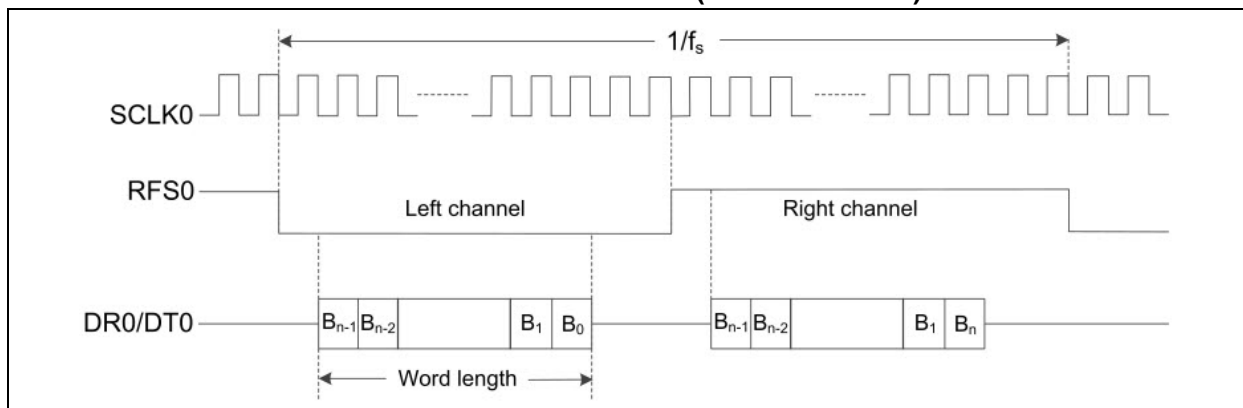
**3:** The current consumption values are measured with the BM63 EVB as a test platform, with BAT\_IN = 3.8V. The distance between the smartphone and BM63 EVB is 30 cm, and the speaker is without loading.

# BM63

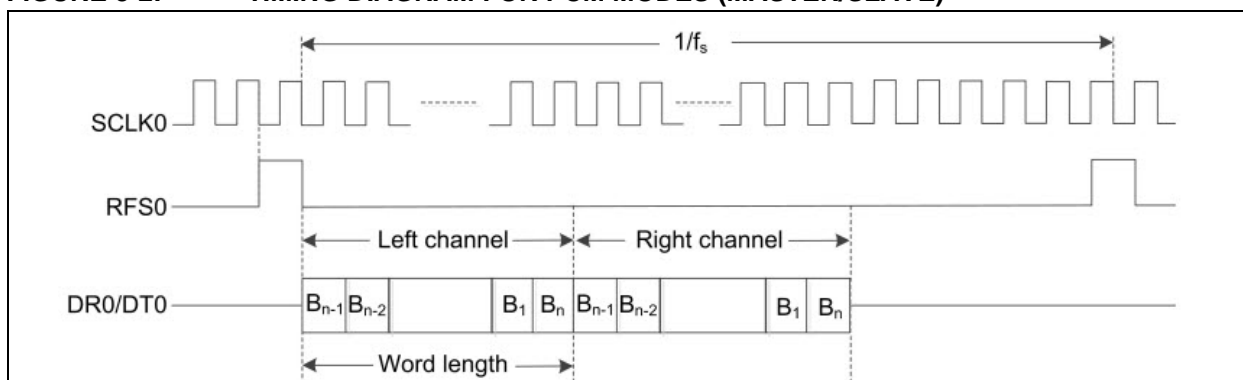
## 8.2 Timing specifications

Figure 8-1 and Figure 8-2 illustrate the timing diagram of the BM63 module in I<sup>2</sup>S and PCM modes.

**FIGURE 8-1: TIMING DIAGRAM FOR I<sup>2</sup>S MODES (MASTER/SLAVE)**



**FIGURE 8-2: TIMING DIAGRAM FOR PCM MODES (MASTER/SLAVE)**



**Note 1:**  $f_s$ : 8, 16, 32, 44.1, 48, 88.2 and 96 kHz.

**2:** SCLK0:  $64 \cdot f_s / 256 \cdot f_s$ .

**3:** Word length: 16-bit and 24-bit.

Figure 8-3 illustrates the timing diagram of the audio interface.

**FIGURE 8-3: AUDIO INTERFACE TIMING DIAGRAM**

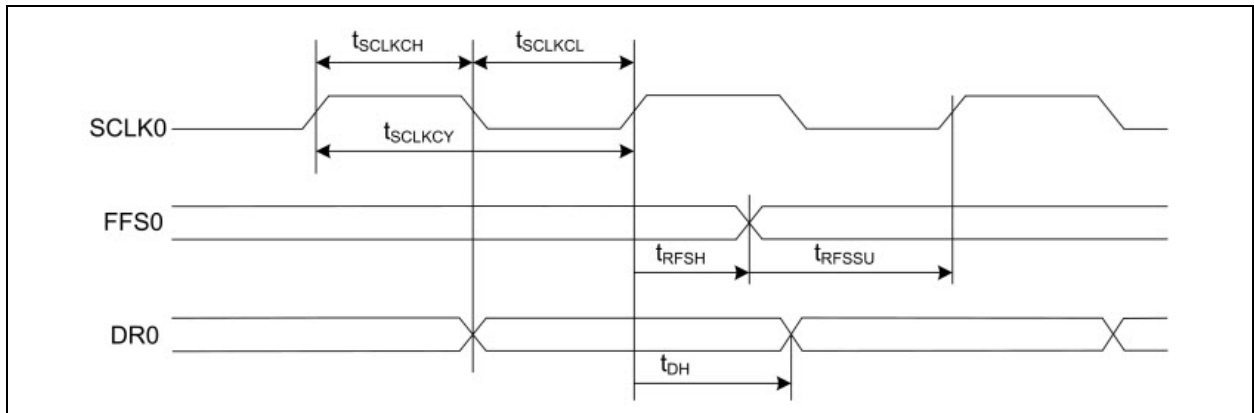


Table 8-10 provides the timing specifications of the audio interface.

**TABLE 8-10: AUDIO INTERFACE TIMING SPECIFICATIONS**

Parameter	Symbol	Min.	Typ.	Max.	Units
SCLK0 duty ratio	$d_{SCLK}$	–	50	–	%
SCLK0 cycle time	$t_{SCLKCY}$	50	–	–	ns
SCLK0 pulse width high	$t_{SCLKCH}$	20	–	–	ns
SCLK0 pulse width low	$t_{SCLKCL}$	20	–	–	ns
RFS0 Setup time to SCLK0 rising edge	$t_{RFSSU}$	10	–	–	ns
RFS0 hold time from SCLK0 rising edge	$t_{RFSH}$	10	–	–	ns
DR0 hold time from SCLK0 rising edge	$t_{DH}$	10	–	–	ns

**Note:** Test Conditions: Slave mode,  $f_s = 48 \text{ kHz}$ , 24-bit data and SCLK0 period =  $256 f_s$ .

# BM63

---

NOTES:

## 9.0 SOLDERING RECOMMENDATIONS

The BM63 module is assembled using a standard lead-free reflow profile, IPC/JEDEC J-STD-020. The BM63 module can be soldered to the main PCB using a standard leaded and lead-free solder reflow profiles.

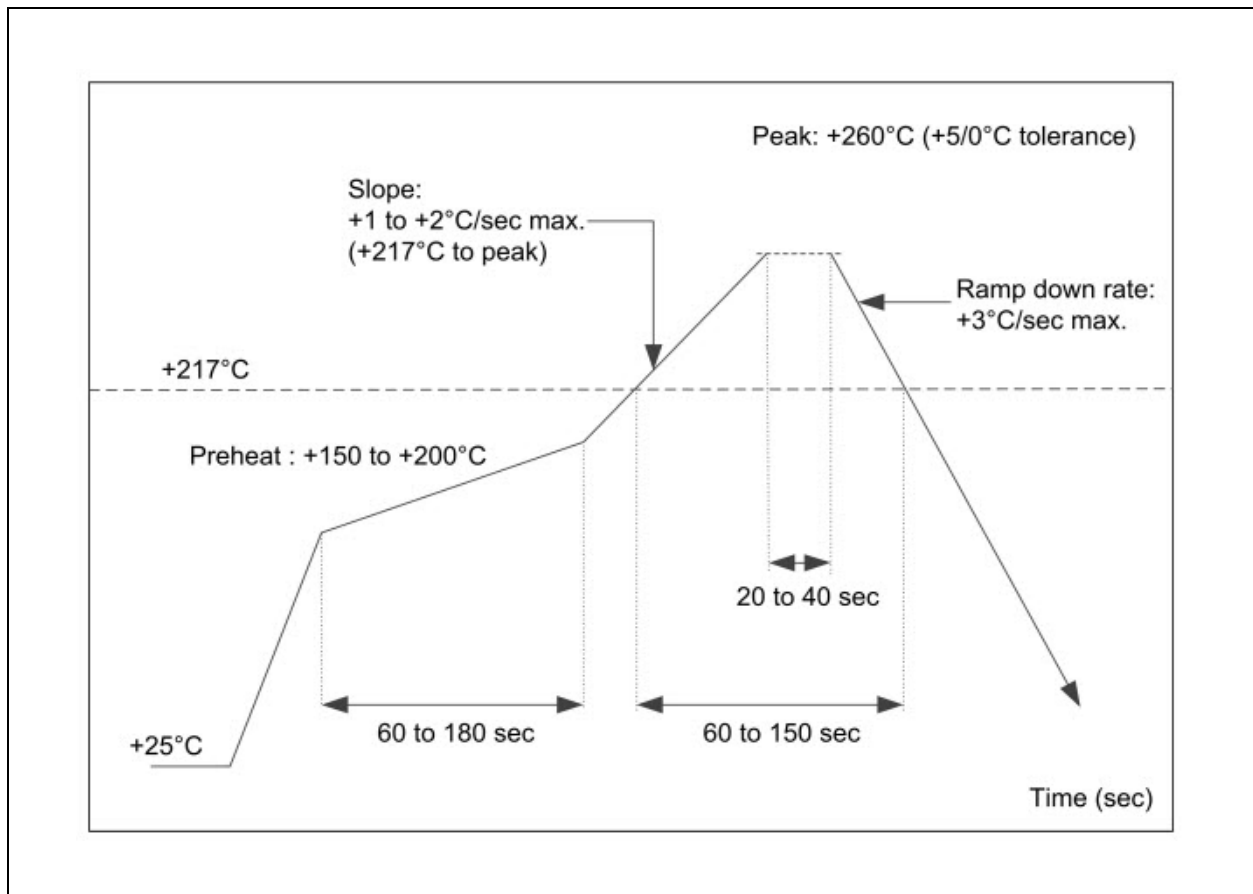
To avoid the damage to the module, follow these recommendations:

- Refer to the “AN233 Solder Reflow Recommendation” (DS00233) document for the soldering reflow recommendations
- The peak temperature ( $T_P$ ) must not exceed +260°C
- Refer to the “Solder Paste” data sheet for specific reflow profile recommendations

- Use no-clean flux solder paste
- Do not wash the module as moisture can be trapped under the shield
- Use only one flow. If the PCB requires multiple flows, apply the module on the final flow.

Figure 9-1 illustrates the reflow profile of the BM63 module.

**FIGURE 9-1: REFLOW PROFILE**



# BM63

---

NOTES:



## 10.0 ORDERING INFORMATION

Table 10-1 provides the ordering information of the BM63 module.

**TABLE 10-1: BM63 MODULE ORDERING INFORMATION**

Module	Microchip IC	Description	Part No
BM63	IS2063GM	Bluetooth 4.2 Stereo Audio with BLE, I <sup>2</sup> S, Flash, Class 2, no shield, built-in antenna	BM63SPKA1MC2

**Note:** The BM63 module can be purchased through a Microchip representative. Go to Microchip website [www.microchip.com](http://www.microchip.com) for the current pricing and a list of distributors for the product.

# BM63

---

NOTES:

---

---

## APPENDIX A: REVISION HISTORY

### Revision A (June 2016)

This is the initial released version of this document.

### Revision B (January 2017)

This revision includes the following changes and minor updates to text and formatting which were incorporated throughout the document.

**TABLE B-1: MAJOR SECTION UPDATES**

Section	Update Description
1.0 "Device Overview"	Added USB and updated the voice prompt details in <a href="#">Table 1-1</a> . Updated <a href="#">Table 1-2</a> with correct pin descriptions.
7.0 "Physical Dimensions"	Added Note to <a href="#">Figure 7-2</a> .

# BM63

---

NOTES:

---

## THE MICROCHIP WEB SITE

Microchip provides online support via our WWW site at [www.microchip.com](http://www.microchip.com). This web site is used as a means to make files and information easily available to customers. Accessible by using your favorite Internet browser, the web site contains the following information:

- **Product Support** – Data sheets and errata, application notes and sample programs, design resources, user's guides and hardware support documents, latest software releases and archived software
- **General Technical Support** – Frequently Asked Questions (FAQ), technical support requests, online discussion groups, Microchip consultant program member listing
- **Business of Microchip** – Product selector and ordering guides, latest Microchip press releases, listing of seminars and events, listings of Microchip sales offices, distributors and factory representatives

## CUSTOMER CHANGE NOTIFICATION SERVICE

Microchip's customer notification service helps keep customers current on Microchip products. Subscribers will receive e-mail notification whenever there are changes, updates, revisions or errata related to a specified product family or development tool of interest.

To register, access the Microchip web site at [www.microchip.com](http://www.microchip.com). Under "Support", click on "Customer Change Notification" and follow the registration instructions.

## CUSTOMER SUPPORT

Users of Microchip products can receive assistance through several channels:

- Distributor or Representative
- Local Sales Office
- Field Application Engineer (FAE)
- Technical Support

Customers should contact their distributor, representative or Field Application Engineer (FAE) for support. Local sales offices are also available to help customers. A listing of sales offices and locations is included in the back of this document.

**Technical support is available through the web site at: <http://microchip.com/support>.**

# BM63

---

NOTES:

---

---

**Note the following details of the code protection feature on Microchip devices:**

- Microchip products meet the specification contained in their particular Microchip Data Sheet.
- Microchip believes that its family of products is one of the most secure families of its kind on the market today, when used in the intended manner and under normal conditions.
- There are dishonest and possibly illegal methods used to breach the code protection feature. All of these methods, to our knowledge, require using the Microchip products in a manner outside the operating specifications contained in Microchip's Data Sheets. Most likely, the person doing so is engaged in theft of intellectual property.
- Microchip is willing to work with the customer who is concerned about the integrity of their code.
- Neither Microchip nor any other semiconductor manufacturer can guarantee the security of their code. Code protection does not mean that we are guaranteeing the product as "unbreakable."

Code protection is constantly evolving. We at Microchip are committed to continuously improving the code protection features of our products. Attempts to break Microchip's code protection feature may be a violation of the Digital Millennium Copyright Act. If such acts allow unauthorized access to your software or other copyrighted work, you may have a right to sue for relief under that Act.

---

Information contained in this publication regarding device applications and the like is provided only for your convenience and may be superseded by updates. It is your responsibility to ensure that your application meets with your specifications. MICROCHIP MAKES NO REPRESENTATIONS OR WARRANTIES OF ANY KIND WHETHER EXPRESS OR IMPLIED, WRITTEN OR ORAL, STATUTORY OR OTHERWISE, RELATED TO THE INFORMATION, INCLUDING BUT NOT LIMITED TO ITS CONDITION, QUALITY, PERFORMANCE, MERCHANTABILITY OR FITNESS FOR PURPOSE. Microchip disclaims all liability arising from this information and its use. Use of Microchip devices in life support and/or safety applications is entirely at the buyer's risk, and the buyer agrees to defend, indemnify and hold harmless Microchip from any and all damages, claims, suits, or expenses resulting from such use. No licenses are conveyed, implicitly or otherwise, under any Microchip intellectual property rights unless otherwise stated.

*Microchip received ISO/TS-16949:2009 certification for its worldwide headquarters, design and wafer fabrication facilities in Chandler and Tempe, Arizona; Gresham, Oregon and design centers in California and India. The Company's quality system processes and procedures are for its PIC® MCUs and dsPIC® DSCs, KEELoQ® code hopping devices, Serial EEPROMs, microperipherals, nonvolatile memory and analog products. In addition, Microchip's quality system for the design and manufacture of development systems is ISO 9001:2000 certified.*

**QUALITY MANAGEMENT SYSTEM  
CERTIFIED BY DNV  
= ISO/TS 16949 =**

**Trademarks**

The Microchip name and logo, the Microchip logo, AnyRate, AVR, AVR logo, AVR Freaks, BeaconThings, BitCloud, CryptoMemory, CryptoRF, dsPIC, FlashFlex, flexPWR, Helder, JukeBlox, KEELoQ, KEELoQ logo, Kleer, LANCheck, LINK MD, maXStylus, maXTouch, MediaLB, megaAVR, MOST, MOST logo, MPLAB, OptoLyzer, PIC, picoPower, PICSTART, PIC32 logo, Prochip Designer, QTouch, RightTouch, SAM-BA, SpyNIC, SST, SST Logo, SuperFlash, tinyAVR, UNI/O, and XMEGA are registered trademarks of Microchip Technology Incorporated in the U.S.A. and other countries.

ClockWorks, The Embedded Control Solutions Company, EtherSynch, Hyper Speed Control, HyperLight Load, IntellIMOS, mTouch, Precision Edge, and Quiet-Wire are registered trademarks of Microchip Technology Incorporated in the U.S.A.

Adjacent Key Suppression, AKS, Analog-for-the-Digital Age, Any Capacitor, AnyIn, AnyOut, BodyCom, chipKIT, chipKIT logo, CodeGuard, CryptoAuthentication, CryptoCompanion, CryptoController, dsPICDEM, dsPICDEM.net, Dynamic Average Matching, DAM, ECAN, EtherGREEN, In-Circuit Serial Programming, ICSP, Inter-Chip Connectivity, JitterBlocker, KleerNet, KleerNet logo, Mindi, MiWi, motorBench, MPASM, MPF, MPLAB Certified logo, MPLIB, MPLINK, MultiTRAK, NetDetach, Omniscient Code Generation, PICDEM, PICDEM.net, PICKit, PICtail, PureSilicon, QMatrix, RightTouch logo, REAL ICE, Ripple Blocker, SAM-ICE, Serial Quad I/O, SMART-I.S., SQI, SuperSwitcher, SuperSwitcher II, Total Endurance, TSHARC, USBCheck, VariSense, ViewSpan, WiperLock, WirelessDNA, and ZENA are trademarks of Microchip Technology Incorporated in the U.S.A. and other countries.

SQTP is a service mark of Microchip Technology Incorporated in the U.S.A.

Silicon Storage Technology is a registered trademark of Microchip Technology Inc. in other countries.

GestIC is a registered trademark of Microchip Technology Germany II GmbH & Co. KG, a subsidiary of Microchip Technology Inc., in other countries.

All other trademarks mentioned herein are property of their respective companies.

© 2016-2017, Microchip Technology Incorporated, All Rights Reserved.

ISBN: 978-1-5224-1256-4



## Worldwide Sales and Service

### AMERICAS

**Corporate Office**  
2355 West Chandler Blvd.  
Chandler, AZ 85224-6199  
Tel: 480-792-7200  
Fax: 480-792-7277  
Technical Support:  
<http://www.microchip.com/support>  
Web Address:  
[www.microchip.com](http://www.microchip.com)

**Atlanta**  
Duluth, GA  
Tel: 678-957-9614  
Fax: 678-957-1455

**Austin, TX**  
Tel: 512-257-3370

**Boston**  
Westborough, MA  
Tel: 774-760-0087  
Fax: 774-760-0088

**Chicago**  
Itasca, IL  
Tel: 630-285-0071  
Fax: 630-285-0075

**Dallas**  
Addison, TX  
Tel: 972-818-7423  
Fax: 972-818-2924

**Detroit**  
Novi, MI  
Tel: 248-848-4000

**Houston, TX**  
Tel: 281-894-5983

**Indianapolis**  
Noblesville, IN  
Tel: 317-773-8323  
Fax: 317-773-5453  
Tel: 317-536-2380

**Los Angeles**  
Mission Viejo, CA  
Tel: 949-462-9523  
Fax: 949-462-9608  
Tel: 951-273-7800

**Raleigh, NC**  
Tel: 919-844-7510

**New York, NY**  
Tel: 631-435-6000

**San Jose, CA**  
Tel: 408-735-9110  
Tel: 408-436-4270

**Canada - Toronto**  
Tel: 905-695-1980  
Fax: 905-695-2078

### ASIA/PACIFIC

**Asia Pacific Office**  
Suites 3707-14, 37th Floor  
Tower 6, The Gateway  
Harbour City, Kowloon

**Hong Kong**  
Tel: 852-2943-5100  
Fax: 852-2401-3431

**Australia - Sydney**  
Tel: 61-2-9868-6733  
Fax: 61-2-9868-6755

**China - Beijing**  
Tel: 86-10-8569-7000  
Fax: 86-10-8528-2104

**China - Chengdu**  
Tel: 86-28-8665-5511  
Fax: 86-28-8665-7889

**China - Chongqing**  
Tel: 86-23-8980-9588  
Fax: 86-23-8980-9500

**China - Dongguan**  
Tel: 86-769-8702-9880

**China - Guangzhou**  
Tel: 86-20-8755-8029

**China - Hangzhou**  
Tel: 86-571-8792-8115  
Fax: 86-571-8792-8116

**China - Hong Kong SAR**  
Tel: 852-2943-5100  
Fax: 852-2401-3431

**China - Nanjing**  
Tel: 86-25-8473-2460  
Fax: 86-25-8473-2470

**China - Qingdao**  
Tel: 86-532-8502-7355  
Fax: 86-532-8502-7205

**China - Shanghai**  
Tel: 86-21-3326-8000  
Fax: 86-21-3326-8021

**China - Shenyang**  
Tel: 86-24-2334-2829  
Fax: 86-24-2334-2393

**China - Shenzhen**  
Tel: 86-755-8864-2200  
Fax: 86-755-8203-1760

**China - Wuhan**  
Tel: 86-27-5980-5300  
Fax: 86-27-5980-5118

**China - Xian**  
Tel: 86-29-8833-7252  
Fax: 86-29-8833-7256

### ASIA/PACIFIC

**China - Xiamen**  
Tel: 86-592-2388138  
Fax: 86-592-2388130

**China - Zhuhai**  
Tel: 86-756-3210040  
Fax: 86-756-3210049

**India - Bangalore**  
Tel: 91-80-3090-4444  
Fax: 91-80-3090-4123

**India - New Delhi**  
Tel: 91-11-4160-8631  
Fax: 91-11-4160-8632

**India - Pune**  
Tel: 91-20-3019-1500

**Japan - Osaka**  
Tel: 81-6-6152-7160  
Fax: 81-6-6152-9310

**Japan - Tokyo**  
Tel: 81-3-6880-3770  
Fax: 81-3-6880-3771

**Korea - Daegu**  
Tel: 82-53-744-4301  
Fax: 82-53-744-4302

**Korea - Seoul**  
Tel: 82-2-554-7200  
Fax: 82-2-558-5932 or  
82-2-558-5934

**Malaysia - Kuala Lumpur**  
Tel: 60-3-6201-9857  
Fax: 60-3-6201-9859

**Malaysia - Penang**  
Tel: 60-4-227-8870  
Fax: 60-4-227-4068

**Philippines - Manila**  
Tel: 63-2-634-9065  
Fax: 63-2-634-9069

**Singapore**  
Tel: 65-6334-8870  
Fax: 65-6334-8850

**Taiwan - Hsin Chu**  
Tel: 886-3-5778-366  
Fax: 886-3-5770-955

**Taiwan - Kaohsiung**  
Tel: 886-7-213-7830

**Taiwan - Taipei**  
Tel: 886-2-2508-8600  
Fax: 886-2-2508-0102

**Thailand - Bangkok**  
Tel: 66-2-694-1351  
Fax: 66-2-694-1350

### EUROPE

**Austria - Wels**  
Tel: 43-7242-2244-39  
Fax: 43-7242-2244-393

**Denmark - Copenhagen**  
Tel: 45-4450-2828  
Fax: 45-4485-2829

**Finland - Espoo**  
Tel: 358-9-4520-820

**France - Paris**  
Tel: 33-1-69-53-63-20  
Fax: 33-1-69-30-90-79

**France - Saint Cloud**  
Tel: 33-1-30-60-70-00

**Germany - Garching**  
Tel: 49-8931-9700  
**Germany - Haan**  
Tel: 49-2129-3766400

**Germany - Heilbronn**  
Tel: 49-7131-67-3636

**Germany - Karlsruhe**  
Tel: 49-721-625370

**Germany - Munich**  
Tel: 49-89-627-144-0  
Fax: 49-89-627-144-44

**Germany - Rosenheim**  
Tel: 49-8031-354-560

**Israel - Ra'anana**  
Tel: 972-9-744-7705

**Italy - Milan**  
Tel: 39-0331-742611  
Fax: 39-0331-466781

**Italy - Padova**  
Tel: 39-049-7625286

**Netherlands - Druen**  
Tel: 31-416-690399  
Fax: 31-416-690340

**Norway - Trondheim**  
Tel: 47-7289-7561

**Poland - Warsaw**  
Tel: 48-22-3325737

**Romania - Bucharest**  
Tel: 40-21-407-87-50

**Spain - Madrid**  
Tel: 34-91-708-08-90  
Fax: 34-91-708-08-91

**Sweden - Gothenberg**  
Tel: 46-31-704-60-40

**Sweden - Stockholm**  
Tel: 46-8-5090-4654

**UK - Wokingham**  
Tel: 44-118-921-5800  
Fax: 44-118-921-5820



## X-ON Electronics

Largest Supplier of Electrical and Electronic Components

*Click to view similar products for [Bluetooth Modules - 802.15.1 category](#):*

*Click to view products by [Microchip manufacturer](#):*

Other Similar products are found below :

[A2541R24A10GM](#) [CYBLE-212023-10](#) [BM78SPP05NC2-0002AA](#) [BM78SPP05MC2-0002AA](#) [CYW20732S](#) [968EMB0019](#) [E73-2G4M08S1CX](#) [TB-03F-AT\\_Mesh](#) [TB-04](#) [TB-04--AT\\_Mesh](#) [BT3L\(jibu\)](#) [BT5S\(xoft\)](#) [BT5S\(4k43\)](#) [BT5S\(jcyv\)](#) [1327](#) [RN42HID-I/RM](#) [ENW-89829C3KF](#) [BLE113-A-V1](#) [BM70BLE01FC2-0B03AA](#) [ACN52832](#) [A2541E24A10GM](#) [RN42-I/RM630](#) [MOTG-BLUETOOTH](#) [ABBTM-2.4GHz-52-T](#) [ABBTM-2.4GHz-T](#) [ABBTM-2.4GHz-T2](#) [ACN52840](#) [AFERO-BL24-01](#) [BLED112](#) [BM62SPKS1MC2-0001AA](#) [BM78SPPS5MC2-0002AA](#) [PX0880/1](#) [DAT12](#) [BM833F](#) [BT680F](#) [PBA31309V1.00](#) [S LK64](#) [ISP1907-LL-ST](#) [ATSAMB11-MR510CA](#) [BM20SPKA1NBC-0001AA](#) [BM20SPKS1NBC-0001AA](#) [BM23SPKS1NB9-0B02AA](#) [BM64SPKS1MC2-0002AA](#) [BM70BLE01FC2-0B04AA](#) [BM70BLES1FC2-0B05BA](#) [BM70BLE01FC2-0B05BA](#) [BM70BLES1FC2-0B04AA](#) [BM77SPP03MC2-0007AA](#) [BM77SPP03MC2-0008AA](#) [BM78SPPS5NC2-0002AA](#) [DM164146](#)