

## 13.56 MHz, CLASS-E, 1KW RF Generator using a Microsemi DRF1200 Driver/MOSFET Hybrid

Gui Choi  
Sr. Application Engineer  
Phone: 541-382-8028, ext. 1205  
[gchoi@microsemi.com](mailto:gchoi@microsemi.com)

The DRF1200/Class-E Reference design is available to expedite the evaluation of the DRF1200 Driver MOSFET hybrid. This Application Note or Reference Design Kit does not represent a finished commercial-ready design. It is only a teaching tool to demonstrate the capability of the DRF1200 under 50 Ohm, flat line condition. Each reference design kit has been verified to perform to the specifications of the application note. The application note contains a parts list, PCB layout and schematic that enables the user to facilitate any repairs resulting beyond its intended use. By purchasing the reference design kit the user takes full responsibility for repair and any modification. No warranties, repair or returns will be accepted.

**The reference design kit contains lethal voltages and high power RF.  
Use safety precautions.**

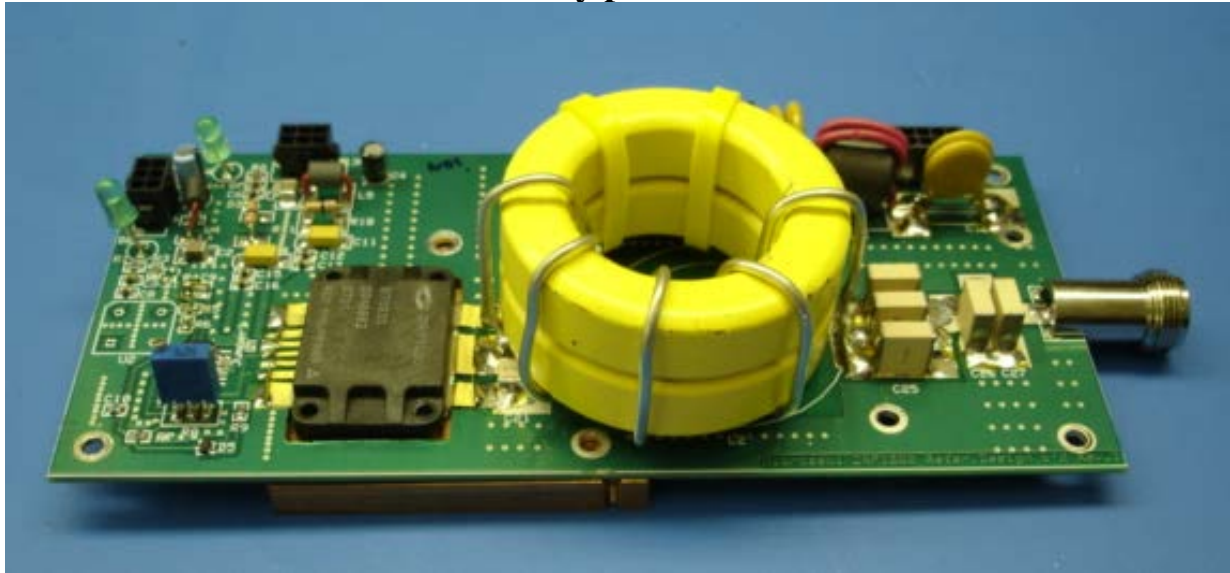

### Contents

- INTRODUCTION
- DESIGN CONSIDERATIONS
- OVERALL CONCEPT
- CIRCUIT DESCRIPTION
  - a. RF PULSE GENERATION CIRCUIT
  - b. RF OUTPUT MATCHING CIRCUIT
  - c. DC SUPPLY
- TEST REQUIREMENTS
- PERFORMANCE (DATA SUMMARY)
- CONCLUSIONS
- APPENDIX I (SCHEMATIC)
- APPENDIX II (PCB LAYOUT)
- APPENDIX III (PARTS LIST)
- REFERENCES

## INTRODUCTION

This application note discusses the design procedures and test results for a 13.56MHz, 1KW, CLASS-E generator ideal for ISM applications. To achieve high efficiency and low cost, a Microsemi DRF1200 Driver/MOSFET was selected. The DRF1200 can generate over 1KW of output power and consists of a MOSFET driver, high power MOSFET and internal bypass capacitors in an air cavity flangeless package. The flangeless package was designed to optimize reliability, provide increased flexibility while still providing a low cost solution. A reference design board (DRF1200/CLASS-E) is available for purchase to facilitate the immediate evaluation of the principles of this application note.

To optimize efficiency performance, a CLASS-E RF generator was chosen. It is essential that care is taken to use adequate circuitry, clean PCB layout and good ground connections on the PCB to ensure proper output waveforms.

## DESIGN CONSIDERATIONS

The following issues were considered in the design of a high efficiency, high power RF generator.

- a. CLASS-E operation for high-efficiency.
- b. Adequate output matching circuit. Matching tools were used to achieve the required power and efficiency.
- c. Parts that are capable of handling RF output of 1KW. This includes the bypass capacitor in the DC circuit and selecting a toroidal inductor and capacitors for output matching circuit.
- d. PCB designed for good ground connections, especially for the output matching circuit.
- e. PCB layout optimizing the isolation between power output and input signal generation circuit.

Table 1 shows the output achieved for this RF Power Generator.

Freq	Output Power	Voltage	Current	Efficiency
13.56Mhz	1KW	320V	3.7A	86%

**Table 1.** Key Specification

## OVERALL CONCEPT

This high efficiency RF power generator uses a DRF1200 to minimize layout parasitics and optimize efficiency for CLASS-D and CLASS-E operation.

- a. **RF pulse generator circuit**  
The pulse oscillator and pulse control circuit is designed to create an ISM frequency of 13.56MHz and adjust the pulse width and phase according to circuit power requirements.
- b. **RF output matching circuit**  
The matching circuit was calculated with a RF matching software tool to maximize power transfer to 50 Ohm load. The circuit was then tuned using the inductor, capacitor and RF choke coil (RFC).

## CIRCUIT DESCRIPTIONS

- a. **RF Pulse Generation**  
The Pulse generation circuit employs 13.56MHz TCXO and Flip Flop IC to adjust Pulse Width from 14nS to 35nS at the signal input of DRF1200. For this application, the pulse width is set at **15nS**. To minimize conductive EMI, it is crucial to use a good ground plane layout with respect to the signal lines.
- b. **RF Output Matching**  
The DRF1200 has a switching speed of 3~4nS, BVds of 1KV and Ids of 13A max. To achieve high-efficiency operation, the RF generator uses CLASS-E operation. At full power, the efficiency is approximately 86% at 13.56MHz. The MOSFET output capacitance was considered when tuning the external shunt capacitance to get the desired performance. See DRF1200 data sheet for output capacitance. The RF output matching circuit was designed using a RF matching tool and was optimized to achieve maximize power transfer to 50 Ohm Load. The output matching circuit is a series resistive circuit combined with a reactive circuit consisting of an "L" match Toroidal Inductor and Capacitors in series and shunt to ground.
- c. **DC Supply**  
The PS HV DC supply input circuit utilizes a RFC and by-pass capacitors to minimize interference with AC signal. The RFC was calculated to be approximately 1K Ohm impedance at 13.56MHz using 30 turns of 20AWG wire. The bypass capacitor should have a minimum 1KV rating.

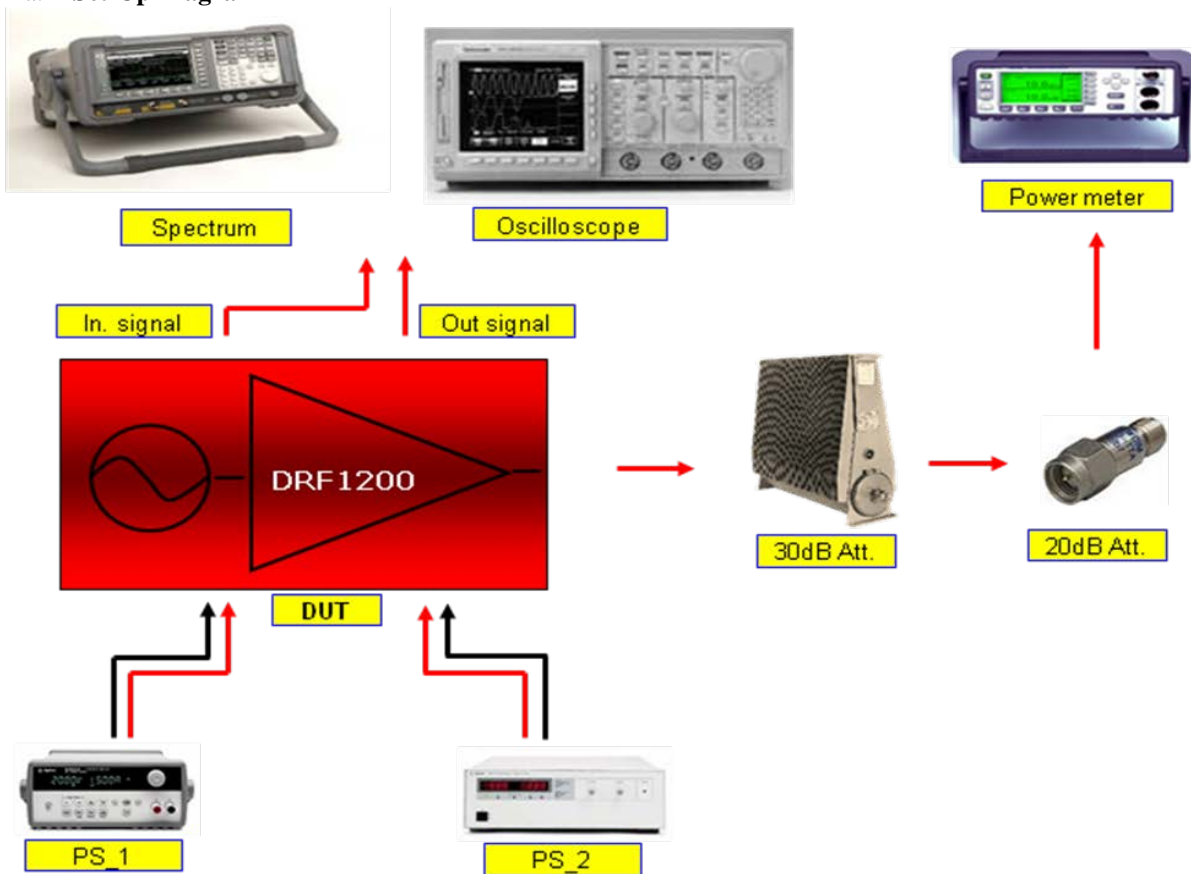
**TEST REQUIREMENTS**
**a. Set-Up Diagram**

**Figure 1.** Test Set-Up diagram

**b. Hardware and power sequencing requirements**

- Cooling requirement: Testing is recommended to be performed using a water cooling system. If not available, should use enough heat sink to maintain continuous testing with sufficient fan capability. A space of approximately 2.5 inches or higher between the fans and the bench floor should be allowed so that air flow is not impeded.
- Sequential steps for Turn-On/Turn Off of Power Supplies.
  1. Turn on Driver power supply PS\_1 (14V via JP1).
  2. Then, turn on MOSFET supply (PS\_2) and slowly increase to 40V (via JP2).
  3. While monitoring the RF power from power meter and output waveform of the Drain, ramp up MOSFET power supply (PS\_2) to the values per Table 2 making sure that output is stable for each supply voltage before proceeding to the next higher voltage.
  4. To turn-off, turn power supplies off in the reverse order.
- If RF output waveform, Vds and/or RF power level from power meter fluctuate, immediately shut down of PS\_2 for safety and determine fault before resuming test.

**PERFORMANCE**

 a. **Data summary**

No\Para.	PS HV (V)	Id (A)	Pin (W)	Pout (W)	H (%)	Vds (V)
1	100	1.1	110.00	104	94.5	276
2	110	1.19	130.90	124	94.7	
3	120	1.3	156.00	149	95.5	
4	130	1.4	182.00	175	96.2	
5	140	1.51	211.40	204	96.5	
6	150	1.63	244.50	235	96.1	
7	160	1.75	280.00	268	95.7	
8	170	1.87	317.90	303	95.3	
9	180	2	360.00	342	95.0	
10	190	2.13	404.70	383	94.6	
11	200	2.25	450.00	424	94.2	576
12	210	2.4	504.00	472	93.7	
13	220	2.52	554.40	515	92.9	
14	230	2.66	611.80	564	92.2	
15	240	2.8	672.00	615	91.5	
16	250	2.95	737.50	669	90.7	
17	260	3.09	803.40	723	90.0	
18	270	3.23	872.10	775	88.9	
19	280	3.38	946.40	830	87.7	
20	290	3.52	1,020.80	882	86.4	
21	300	3.66	1,098.00	940	85.6	
22	320	3.7	1,155.00	1000	86.1	925

**Table 2.** Power Sequencing Data Summary

Table 2 shows the effects of varying the PS HV on MOSFET current, RF power, efficiency, and peak Vds. Efficiency vs. Pout is shown in Figure 2 and peak Vds vs. PS HV is shown in Figure 3. The efficiency is calculated using RF power output and DC input power of the power MOSFET. Efficiency remains higher than 94% up to RF power of 500W and 90% up to 800W. At RF output power of 1KW, the efficiency is reduced slightly to approximately 86%.

Figure 3 shows that the peak drain voltage (Vds) is approximately 3 times the PS HV voltage. This is close to the ideal value of 3.5 times PS HV voltage.

Figure 4 shows that the peak Vds is 276V when the PS HV voltage is 100V. Figure 5 shows that a peak Vds of 576V is achieved with a PS HV voltage setting of 200V. Figure 6 shows that a peak Vds of 876V is achieved with a PS HV voltage setting of 300V.

b. Chart of data sheet

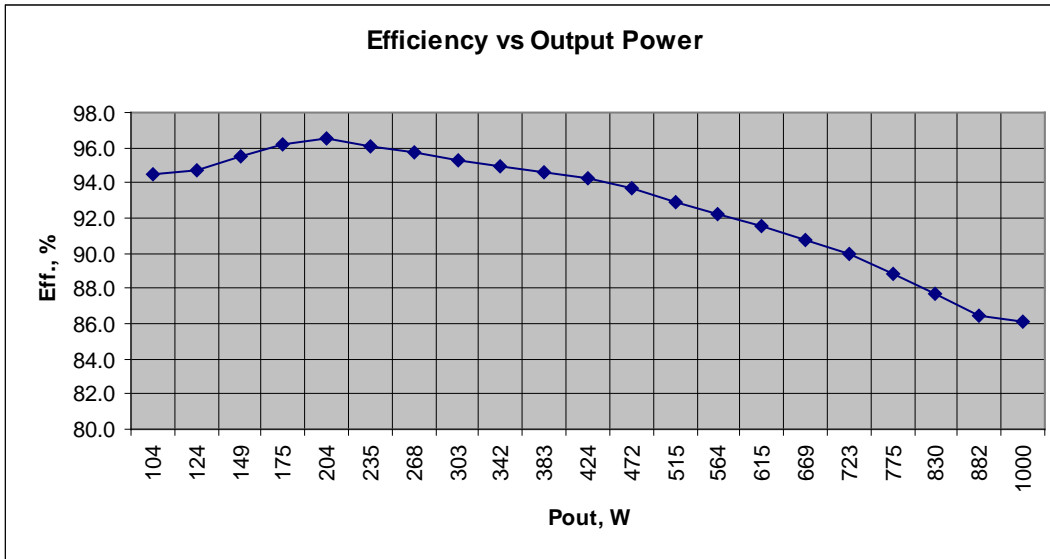

Figure 2. Efficiency vs. Pout

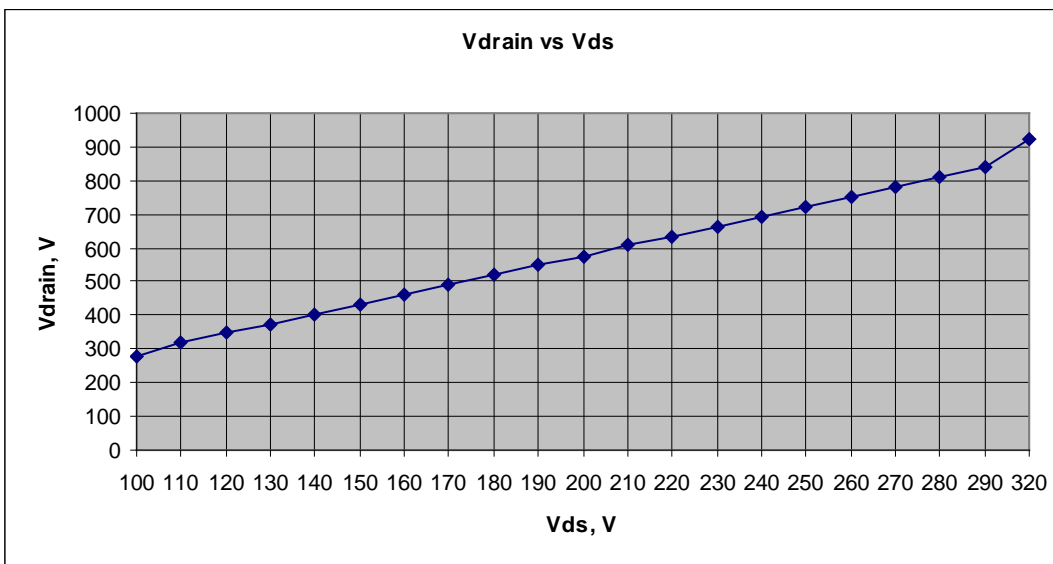

Figure 3. Vds vs. HV

c. Waveform at MOSFET Drain for various settings of the HV PS

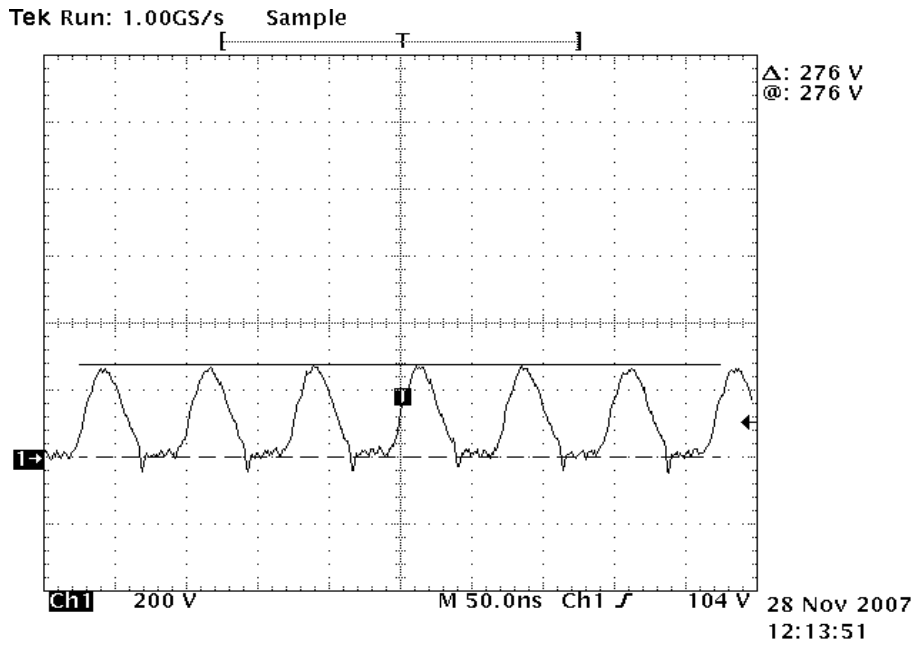

Figure 4. Peak VDS (PS HV = 100V)

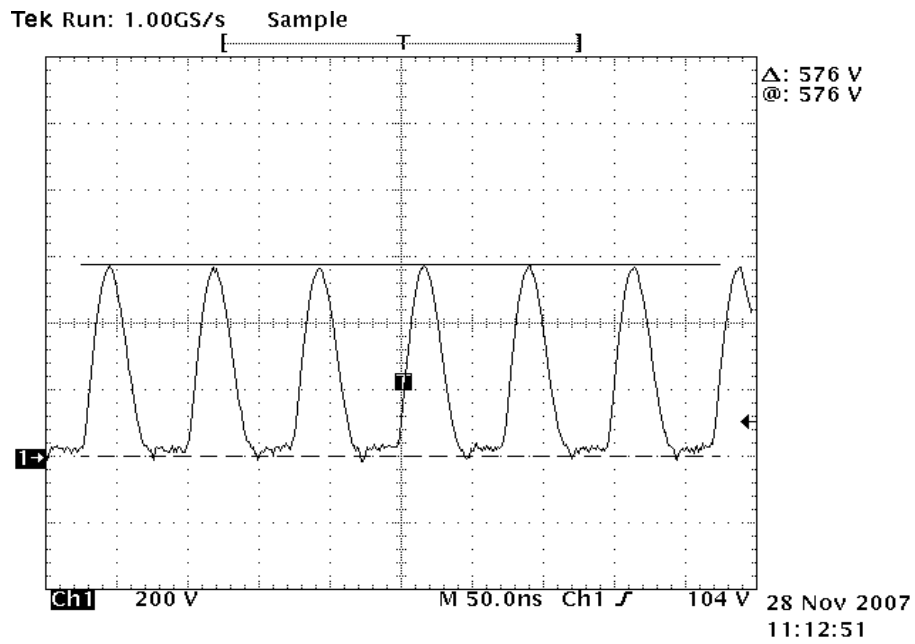
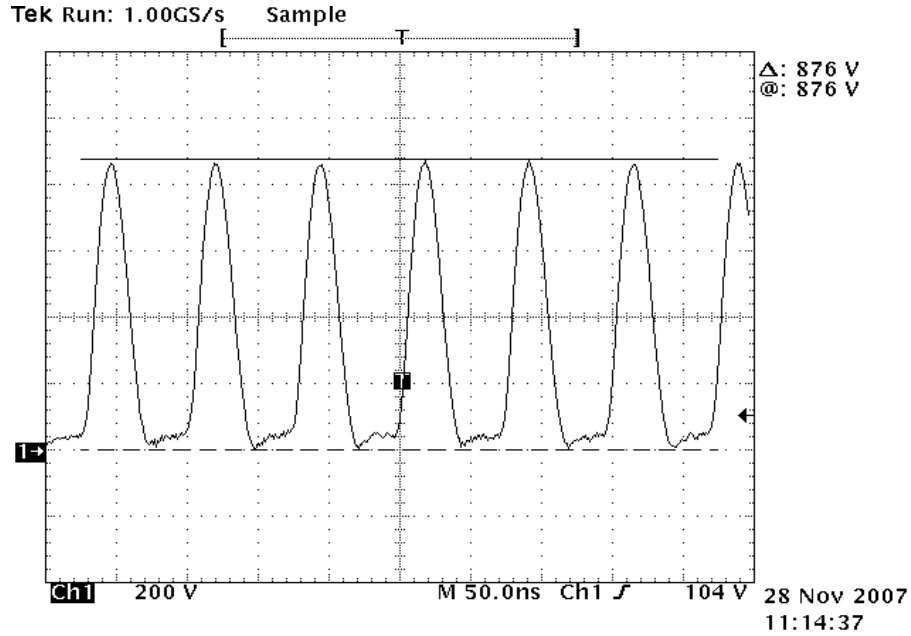

Figure 5. Peak VDS (PS HV = 200V)



**Figure 6. Peak VDS (PS HV = 300V)**

## CONCLUSIONS

This application note is for a reference design using a DRF1200 as a CLASS-E RF generator. The high performance DRF1200 Hybrid was used because it includes both the driver, Power MOSFET, and bypass capacitors optimized to reduce inductance and achieve a single low-cost solution. A reference design board is available to demonstrate this high efficiency, 1KW, 13.56MHz RF generator with 86% efficiency using a drain supply voltage up to 320Vdc.

The critical aspects such as the layout of components for efficient power generation, testing, and air cooling requirements are also discussed.

## Test Setup

It is highly recommended that a Common Mode Choke (CMC) is used on all power and measurement inputs and outputs. This approach provides the best stability and the most accurate measurements.

Construction of CMC's are illustrated below. The CMC on the left should be used for PS 1 and the PS 2 inputs. These lines are tightly twisted pairs (5-8 twists per inch). The CMC on the right should be used for the Scope Probe Cable. Three to five turns on each is sufficient. The CMC's should be placed as close to the DRF1200/CLASS-E Board as practical. **Bench test pictures are included where Fair-Rite part number 0431164181 has been used in three places for power supply isolation.**

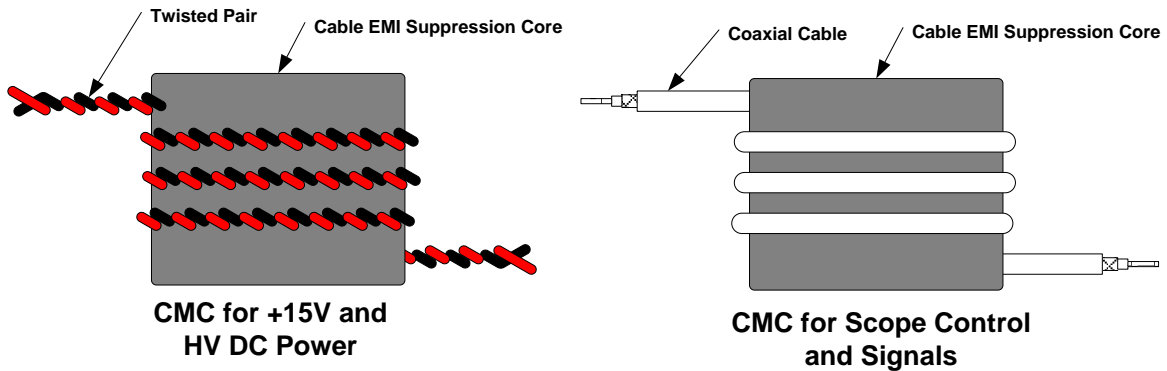

## Appendix I. Overall Schematic

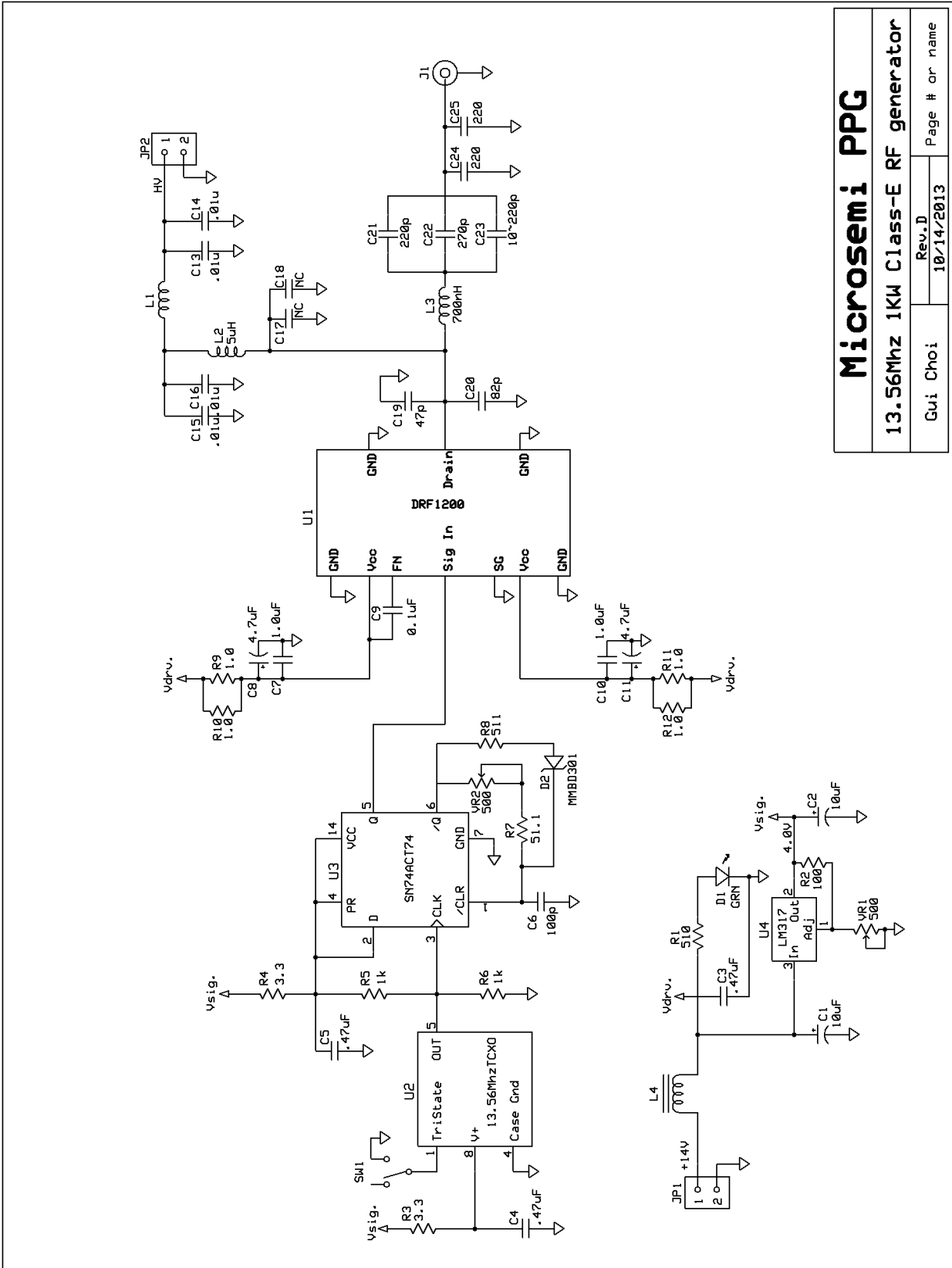

<b>Microsemi PPG</b>	
<b>13.56Mhz 1KW Class-E RF generator</b>	
Gui Choi	Rev.D
	10/14/2013
	Page # or name

Figure 7. Overall schematic



## Appendix II. PCB Layout

PCB size: 3.5W \* 7.5L in inch  
PCB: FR-4, 65mil T

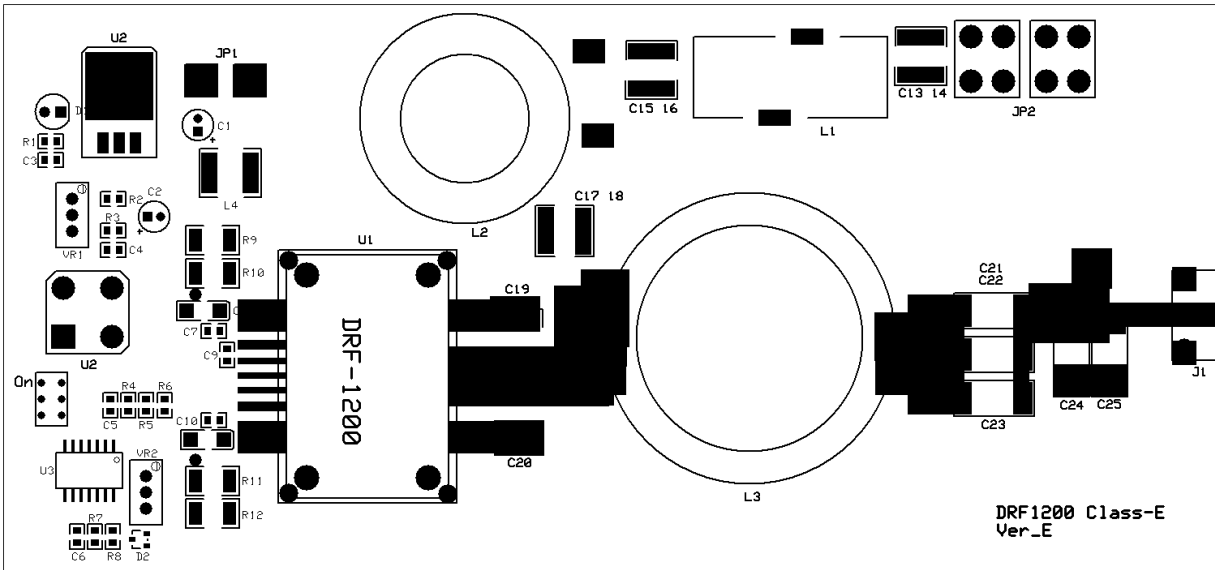

Figure 8. PCB Layout

## Appendix III. Parts List

Part ID	Description	Size	Supplier	Supplier PN	Manufacturer	Manuf. PN
<b>U1</b>	<b>RF MOSFET Hybrid</b>	<b>T3B</b>	<b>Microsemi</b>	<b>DRF1200</b>	<b>Microsemi</b>	<b>DRF1200</b>
C1	10uF/35V	1812	Digi-key	pcc2183ct-nd		
C2	10uF/16V	5*11	Mouser	140-XRL16V10-RC	Xicon	140-XRL16V10-RC
C3	.47uF/50V	0805	Digi-key	490-3328-1-ND		GRM21BR71H474KA88L
C4	.47uF/50V	0805	Digi-key	490-3328-1-ND		GRM21BR71H474KA88L
C5	.47uF/50V	0805	Digi-key	490-3328-1-ND		GRM21BR71H474KA88L
C6	100pF/50V	0805	Digi-key	PCC101CGCT-ND		
C7	1.0uF/50V	0805	Digi-key	587-1438-1-ND	Taiyo Yuden	GMK212BJ105KG-T
C8	4.7uF35V	6032-28	Digi-key	478-1717-1-ND		
C9	0.1uF	0805			Taiyo Yuden	UMK212B7104KG-T
C10	1.0uF/50V	0805	Digi-key	587-1438-1-ND	Taiyo Yuden	GMK212BJ105KG-T
C11	4.7uF35V	6032-28	Digi-key	478-1717-1-ND		
C13	0.01uF/1KV	Cer. Disc	Newark	18M6914		
C14	0.01uF/1KV	Cer. Disc	Newark	18M6914		
C15	0.01uF/1KV	Cer. Disc	Newark	18M6914		
C16	0.01uF/1KV	Cer. Disc	Newark	18M6914		
C17	NC					
C18	NC					
C19	47PF/2500V	3838	ATC	700C470JW2500X	ATC	700C470JW2500X
C20	82PF/2500V	3838	ATC	700C820JW2500X	ATC	700C820JW2500X
C21	220PF/3600V	3838	ATC	100E221KW3600X	ATC	100E221KW3600X
C22	270PF/3600V	3838	ATC	100E271KW3600X	ATC	100E271KW3600X
C23	10~220pF	3838	ATC	100E Series		
C24	220PF/3600V	3838	ATC	100E221KW3600X	ATC	100E221KW3600X
C25	220PF/3600V	3838	ATC	100E221KW3600X	ATC	100E221KW3600X
R1	510ohm/1/8W	0805	Digi-key	P510ATR-ND	Panasonic	ERJ-6GEYJ511V
R2	100ohm 1/8W	0805				
R3	3.3ohm 1/8W	0805	Digi-key	P3.3ACT-ND	Panasonic	ERJ-6GEYJ3R3V
R4	3.3ohm 1/8W	0805	Digi-key	P3.3ACT-ND	Panasonic	ERJ-6GEYJ3R3V
R5	1.0K ohm 1/8W	0805	Digi-key	P1.00KCCT-ND	Panasonic	ERJ-ENF1001V
R6	1.0K ohm 1/8W	0805	Digi-key	P1.00KCCT-ND	Panasonic	ERJ-ENF1001V
R7	51.1ohm 1/8W	0805	Digi-key	P51.1CCT-ND	Panasonic	ERJ-6ENF51R1V
R8	511ohm 1/8W	0805	Digi-key	P511CCT-ND	Panasonic	ERJ-6ENF5110V
R9	1ohm 1/2W	Axial	Digi-key	P1.0BBCT-ND	Panasonic	ERD-S1TJ1R0V
R10	1ohm 1/2W	Axial	Digi-key	P1.0BBCT-ND	Panasonic	ERD-S1TJ1R0V
R11	1ohm 1/2W	Axial	Digi-key	P1.0BBCT-ND	Panasonic	ERD-S1TJ1R0V
R12	1ohm 1/2W	Axial	Digi-key	P1.0BBCT-ND	Panasonic	ERD-S1TJ1R0V
VR1	POT 500ohm	3/8" sq	Digi-key	3292W-501-ND	Bourns	SM:3269W-1 501
VR2	POT 500ohm	3/8" sq	Digi-key	3292W-501-ND	Bourns	SM:3269W-1 501
D1	LED, green	5mm	Digi-key	P375-ND	Panasonic	LN31GPH
D2	30V/300mA	SOT23	Digi-key	MMBD301LT1GOSCT-ND	On Semi.	MMBD301LT1G
J1	RFout port		Newark	12M4398	Bomar	161V504E
JP1	DC Terminal		Allied	839-0309	Keystone	8191
JP2	DC Terminal		Allied	839-0309	Keystone	8191
L1	Inductor w/ 2T AWG18		Newark Fair-Rite	05H7486 2643540302	MCM Fair-Rite	18PE 1/4LB 2643540302
L2	Inductor w/ 20T AWG18		Newark Micrometals	05H7486 T106-1	MCM Micrometals	18PE 1/4LB T106-2
L3	Toroid Inductor 5T 12AWG		Micrometals Mouser	T225-6 5 --- 2ea 602-289-100	Micrometals Alpha	T225-6 5 289
L4	Toroid Inductor 2T 18AWG		Allied Elec. Digikey	2643540302 A5857R-100-ND	Fair-Rite Alpha	2643540302 5857 RD005
U2	13.56 MHz Osc	Half	Allied Elec.	EP1100HSTSC-13.56M	Ecliptek Co.	EP1100HSTSC-13.560M
U3	Dual Flip-Flop IC	14SOP	Digi-key	296-13131-1-ND	TI	SN74ACT74NSR

### References

- Solid State Radio Engineering – Herbert L. Krauss and Charles W. Bostian
- Application Note: Simple and Inexpensive High Efficiency Power Amp using New APT MOSFET – Kenneth Dierberger 1994
- Application Note: PRF-1150 1KW 13.56MHz Class E RF Generator Evaluation Module – Matthew W. Vanis

## X-ON Electronics

Largest Supplier of Electrical and Electronic Components

*Click to view similar products for [Sub-GHz Development Tools](#) category:*

*Click to view products by [Microchip](#) manufacturer:*

Other Similar products are found below :

[EVAL-ADF7021DBJZ](#) [EVAL-ADF7021-NDBZ2](#) [EVAL-ADF7021-VDB3Z](#) [EVAL-ADF7023DB3Z](#) [MICRF219A-433 EV](#) [MICRF220-433 EV](#) [AD6679-500EBZ](#) [EVAL-ADF7901EBZ](#) [EVAL-ADF790XEBZ](#) [110976-HMC453QS16G](#) [STEVAL-IKR002V7D](#) [MAX2602EVKIT+](#) [MAX1472EVKIT-315](#) [MAX1479EVKIT-315](#) [STEVAL-IKR002V3D](#) [MAX7042EVKIT-315+](#) [MAX2902EVKIT#](#) [MAX9947EVKIT+](#) [MAX1470EVKIT-315](#) [SKY66188-11-EK1](#) [SKY66013-11-EVB](#) [EVAL-ADF7023DB5Z](#) [DRF1200/CLASS-E 1096](#) [1098](#) [MDEV-900-PRO DVK-SFUS-1-GEVK](#) [DVK-SFUS-API-1-GEVK](#) [US-SIGFOX-GEVB](#) [STEVAL-IKR002V2D](#) [107755-HMC454ST89](#) [DM182017-2](#) [110961-HMC453ST89](#) [DM182017-1](#) [SX1272MB2DAS 3179](#) [DC689A](#) [DC1513B-AB 3229](#) [3230](#) [3231](#) [3232](#) [DC963B](#) [DC1250A-AA](#) [DC1513B-AC](#) [DC1513B-AD](#) [DC1513B-AA](#) [TEL0075](#) [131903-HMC921LP4E](#) [EU-SIGFOX-GEVB](#)