



General Description

The DSC1001 is a silicon MEMS based CMOS oscillator offering excellent jitter and stability performance over a wide range of supply voltages and temperatures. The device operates from 1 to 150MHz with supply voltages between 1.8 to 3.3 Volts and temperature ranges up to -40°C to 105°C.

The DSC1001 incorporates an all silicon resonator that is extremely robust and nearly immune to stress related fractures, common to crystal based oscillators. Without sacrificing the performance and stability required of today's systems, a crystal-less design allows for a higher level of reliability, making the DSC1001 ideal for rugged, industrial, and portable applications where stress, shock, and vibration can damage quartz crystal based systems.

Available in industry standard packages, the DSC1001 can be "dropped-in" to the same PCB footprint as standard crystal oscillators.

Block Diagram

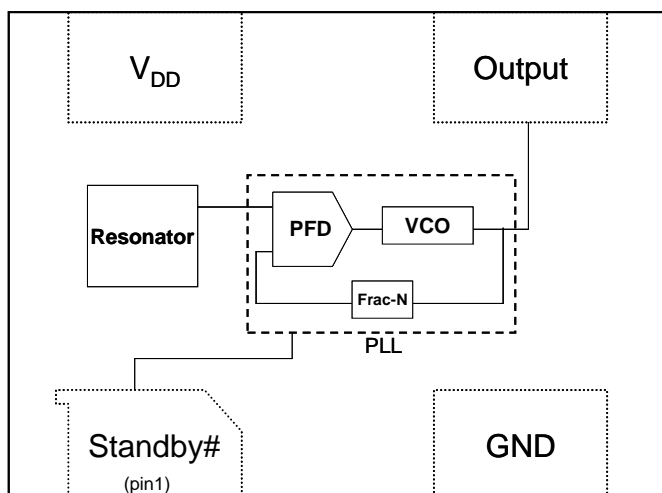

Features

- Frequency Range: 1 to 150MHz
- Exceptional Stability over Temperature
 - ±10 PPM, ±25 PPM, ±50 PPM
- Operating voltage
 - 1.7 to 3.6V
- Operating Temperature Range
 - Ext. Industrial -40°C to 105°C
 - Industrial -40°C to 85°C
 - Ext. Commercial -20°C to 70°C
 - Commercial 0°C to 70°C
- Low Operating and Standby Current
 - 5mA Operating (40MHz)
 - 15uA Standby
- Ultra Miniature Footprint
 - 2.5 x 2.0 x 0.85 mm
 - 3.2 x 2.5 x 0.85 mm
 - 5.0 x 3.2 x 0.85 mm
 - 7.0 x 5.0 x 0.85 mm
- MIL-STD 883 Shock and Vibration Resistant
- Pb Free, RoHS, Reach SVHC Compliant
- AEC-Q100 Reliability Qualified

Benefits

- Pin for pin "drop in" replacement for industry standard oscillators
- Semiconductor level reliability, significantly higher than quartz
- Short mass production lead-times
- Longer Battery Life / Reduced Power
- Compact Plastic package
- Cost Effective

Applications

- Mobile Applications
- Consumer Electronics
- Portable Electronics
- DVR, CCTV, Surveillance Cameras
- Low Profile Applications
- Industrial Applications

Absolute Maximum Ratings¹

Item	Min	Max	Unit	Condition
Input Voltage	-0.3	VDD+0.3	V	
Junction Temp	-	+150	°C	
Storage Temp	-55	+150	°C	
Soldering Temp	-	+260	°C	40 sec max.
ESD	-		V	
HBM		4000		
MM		200		
CDM		1500		

Ordering Code

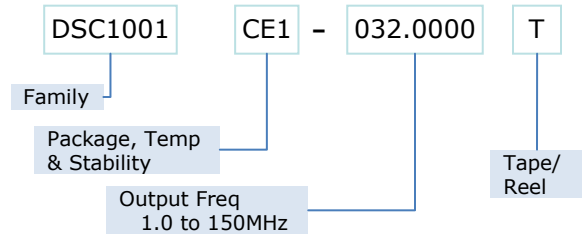

* See Ordering Information for details

Recommended Operating Conditions

Parameter	Symbol	Range
Supply Voltage	V _{DD}	1.7 – 3.6V
Output Load	Z _L	R>10KΩ, C≤15pF
Operating Temperature	T	-40 to +105 °C
Option 1		-40 to +85 °C
Option 2		-20 to +70 °C
Option 3		0 to +70 °C
Option 4		

Specifications (VDD = 1.8 to 3.3v) T_A=85°C unless otherwise specified

Parameter	Symbol	Condition	Min	Typ	Max	Unit
Frequency	f ₀	Single Frequency	1		150	MHz
Frequency Tolerance	Δf	Includes frequency variations due to initial tolerance, temperature and power supply voltage			±10,±25,±50	ppm
Aging	Δf	1 year @25°C			±5	ppm
Supply Current, standby	I _{DD}	T=25°C			15	uA
Output Logic Levels	V _{OH} V _{OL}	-4mA 4mA	0.8*V _{DD}		-	Volts
Output logic high			-		0.2*V _{DD}	
Output logic low						
Output Startup Time ²	t _{SU}	T=25°C		1.0	1.3	ms
Output Disable Time	t _{DA}			20	100	ns
Output Duty Cycle	SYM		45		55	%
Input Logic Levels	V _{IH} V _{IL}		0.75*V _{DD}		-	Volts
Input logic high			-		0.25* V _{DD}	
Input logic low						

VDD = 1.8v

Parameter	Symbol	Condition		Min	Typ	Max	Unit
Supply Current, no load	I_{DD}	$C_L=0p$ $R_L=\infty$ $T=25^\circ C$	1MHz		6.0	6.3	mA
			27MHz		6.5	6.9	
			70MHz		7.2	7.5	
			150MHz		8.3	9.1	
Output Transition time		$C_L=15pF; T=25^\circ C$					
Rise Time	t_R	$20\%/80\%*V_{DD}$			1.8	3	ns
Fall Time	t_F				1.0	3	
Jitter, Max Cycle to Cycle	J_{CC}	$F = 100MHz^3$			60		Ps

VDD = 2.5v

Parameter	Symbol	Condition		Min	Typ	Max	Unit
Supply Current, no load	I_{DD}	$C_L=0p$ $R_L=\infty$ $T=25^\circ C$	1MHz		6.0	6.3	mA
			27MHz		6.7	7.0	
			70MHz		7.7	8.1	
			150MHz		9.6	10.6	
Output Transition time		$C_L=15pF; T=25^\circ C$					
Rise Time	t_R	$20\%/80\%*V_{DD}$			1.0	2	ns
Fall Time	t_F				0.9	2	
Jitter, Max Cycle to Cycle	J_{CC}	$F = 100MHz^3$			50		ps

VDD = 3.3v

Parameter	Symbol	Condition		Min	Typ	Max	Unit
Supply Current, no load	I_{DD}	$C_L=0p$ $R_L=\infty$ $T=25^\circ C$	1MHz		6.0	6.3	mA
			27MHz		6.8	7.2	
			70MHz		8.2	8.7	
			150MHz		10.8	12.2	
Output Transition time		$C_L=15pF; T=25^\circ C$					
Rise Time	t_R	$20\%/80\%*V_{DD}$			1.0	2	ns
Fall Time	t_F				0.9	2	
Jitter, Max Cycle to Cycle	J_{CC}	$F = 100MHz^3$			50		ps

Notes:

1. Absolute maximum ratings are those values beyond which the safety of the device cannot be guaranteed. The device should not be operated beyond these limits.
2. t_{SU} is time to stable output frequency after V_{DD} is applied. t_{SU} and t_{EN} (after EN is asserted) are identical values.
3. Measured over 50k clock cycles.

Nominal Performance Characteristics

Supply Current

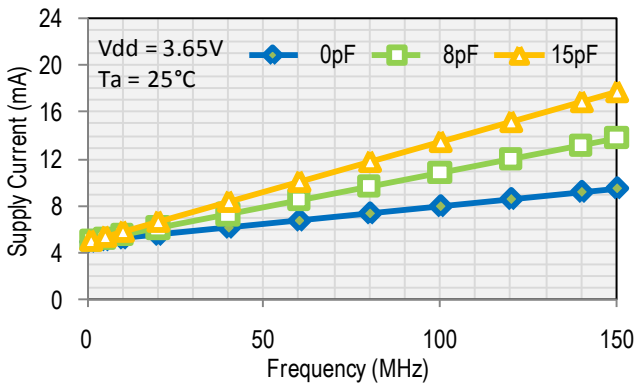

Supply Current

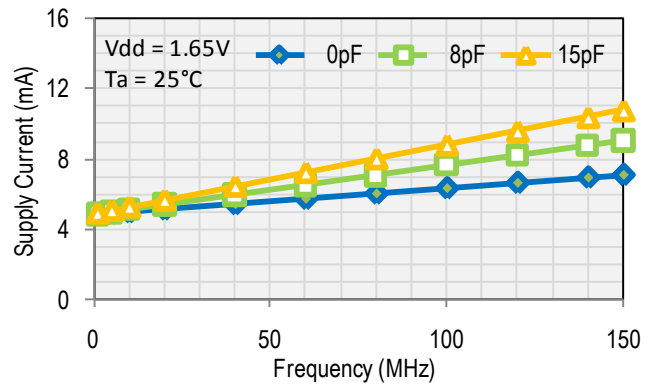

Rise Time

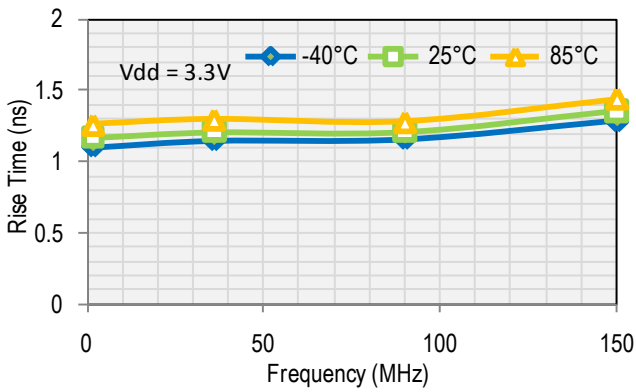

Fall Time

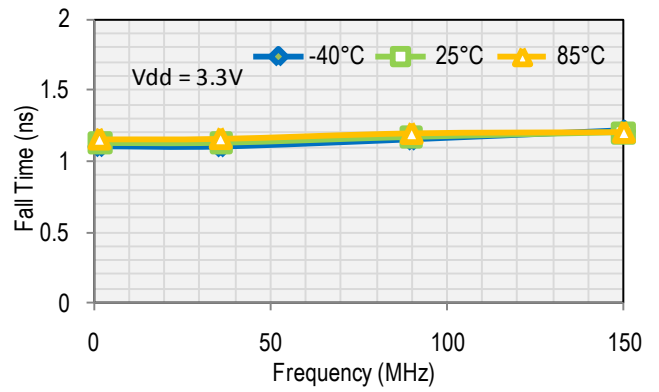

Rise Time

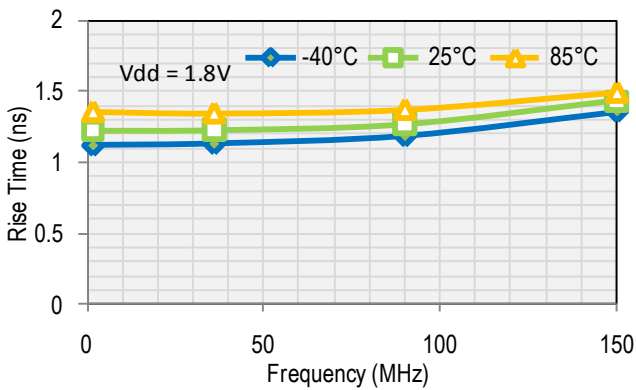

Fall Time

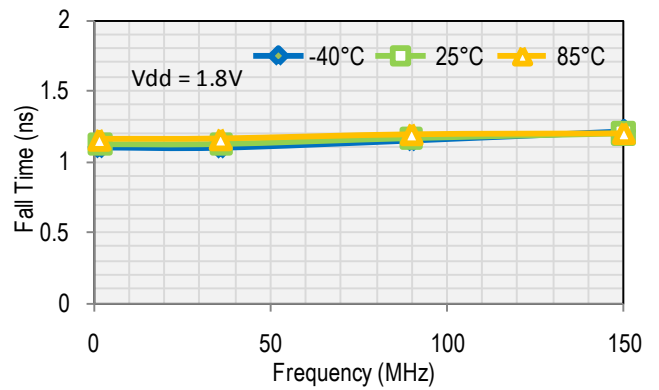

Output Waveform

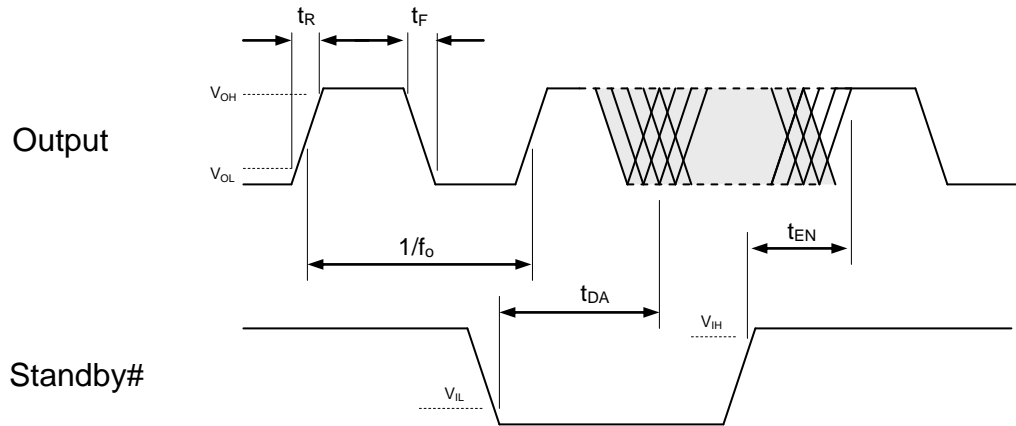

Standby Function

Standby# (pin 1)	Output (pin 3)
Hi Level	Output ON
Open (no connect)	Output ON
Low Level	High Impedance

Test Circuit

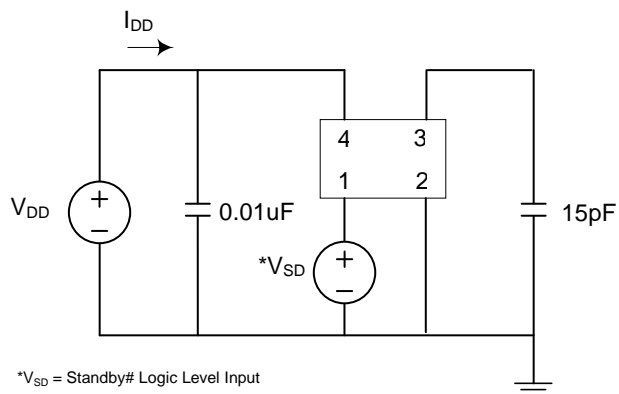

Board Layout (recommended)

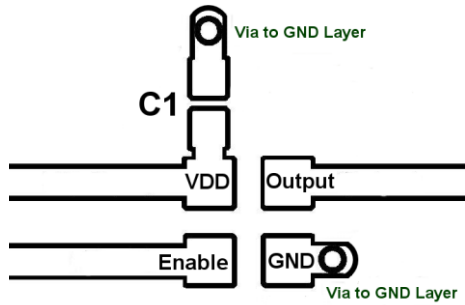

Solder Reflow Profile

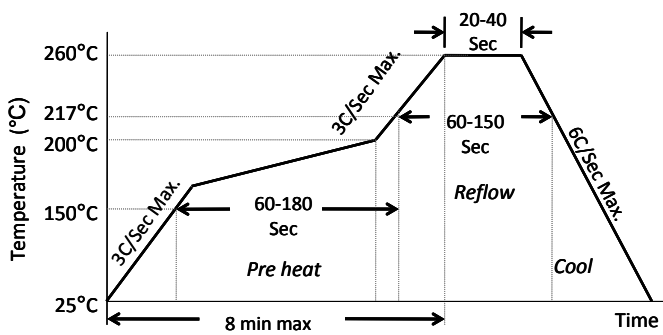

MSL 1 @ 260°C refer to JSTD-020C	
Ramp-Up Rate (200°C to Peak Temp)	3°C/Sec Max.
Preheat Time 150°C to 200°C	60-180 Sec
Time maintained above 217°C	60-150 Sec
Peak Temperature	255-260°C
Time within 5°C of actual Peak	20-40 Sec
Ramp-Down Rate	6°C/Sec Max.
Time 25°C to Peak Temperature	8 min Max.

Package Dimensions

7.0 x 5.0 mm Plastic Package

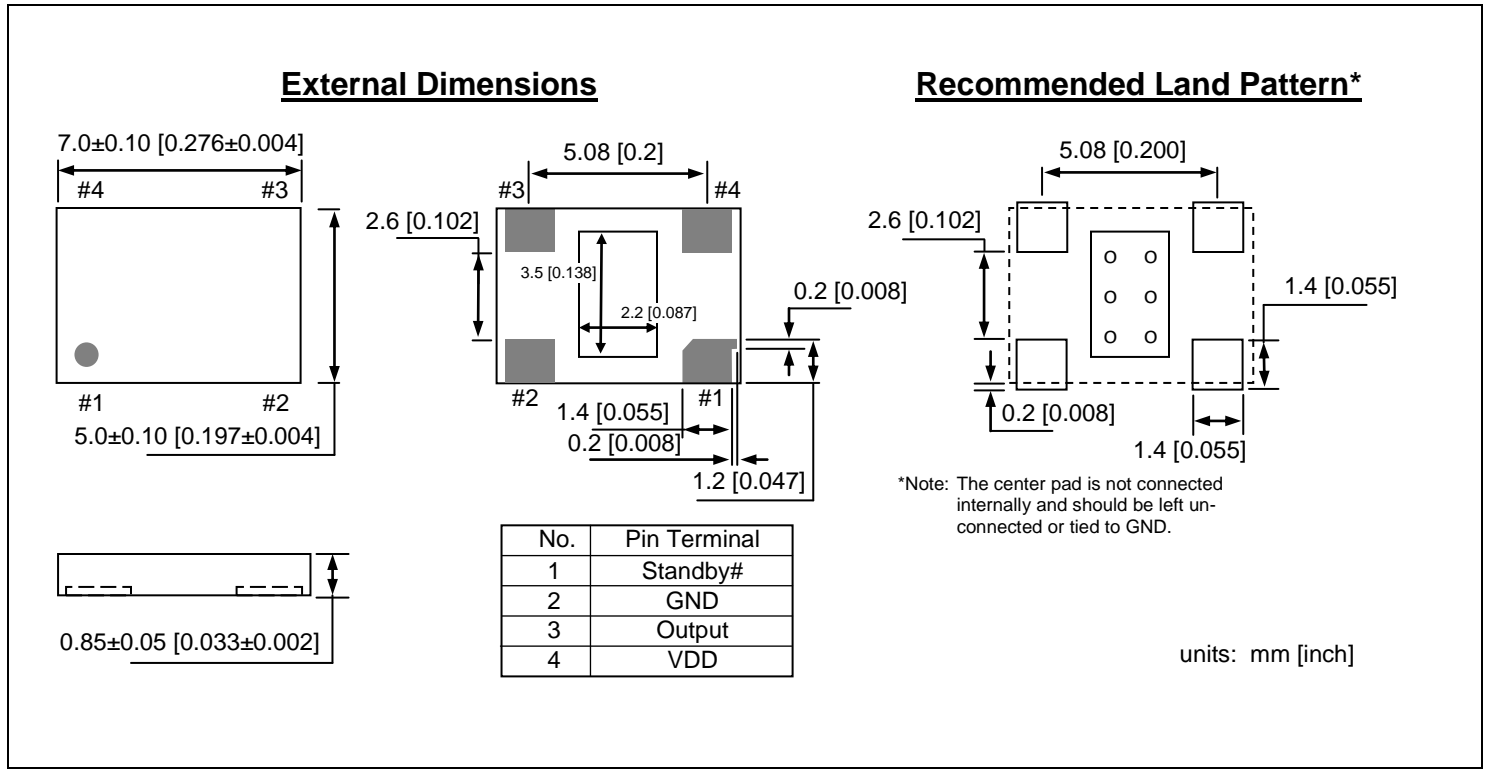

5.0 x 3.2 mm Plastic Package

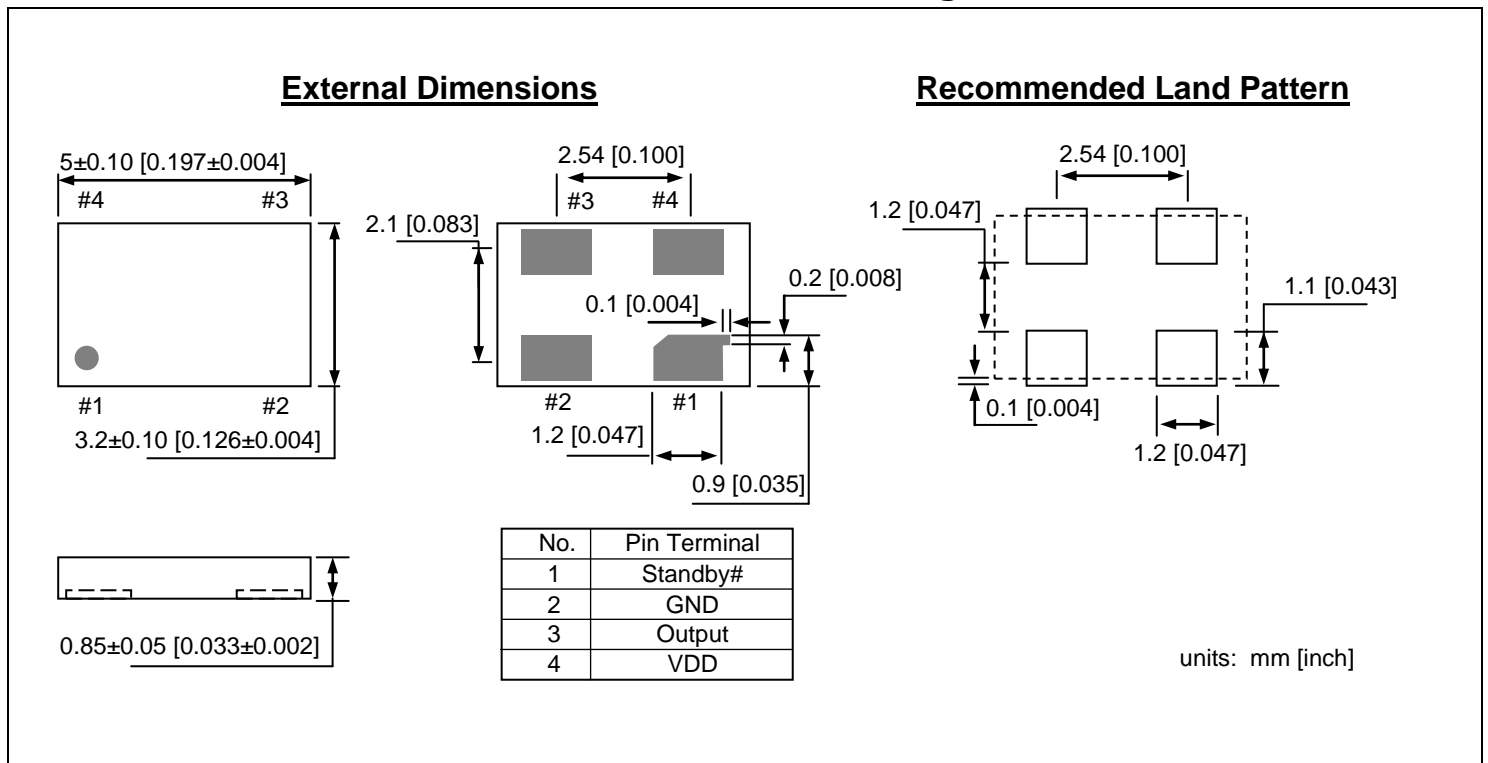

3.2 x 2.5 mm Plastic Package

External Dimensions

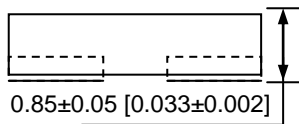
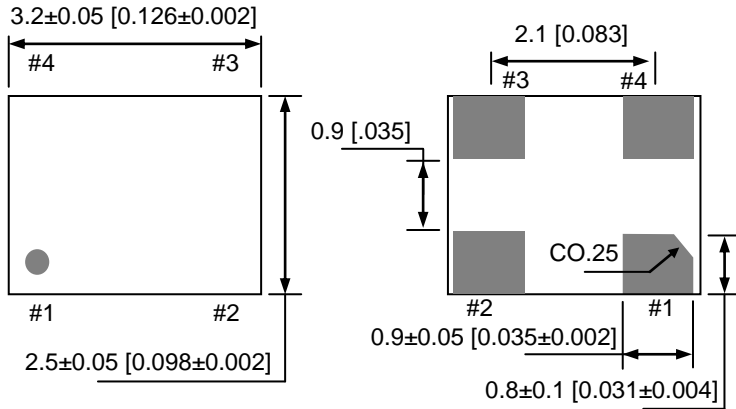

No.	Pin Terminal
1	Standby#
2	GND
3	Output
4	VDD

Recommended Land Pattern

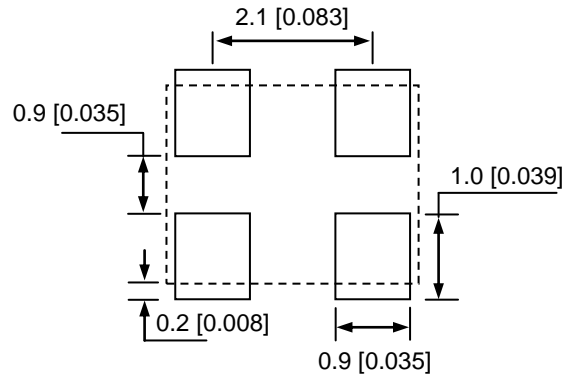

units: mm [inch]

2.5 x 2.0 mm Plastic Package

External Dimensions

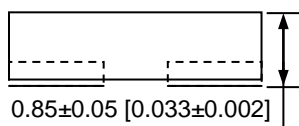
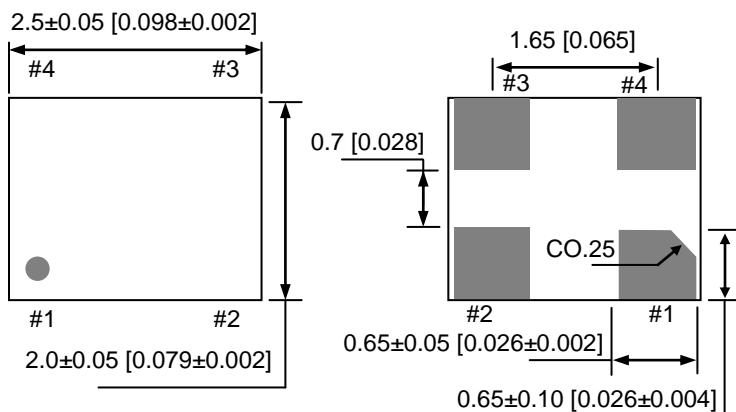

No.	Pin Terminal
1	Standby#
2	GND
3	Output
4	VDD

Recommended Land Pattern

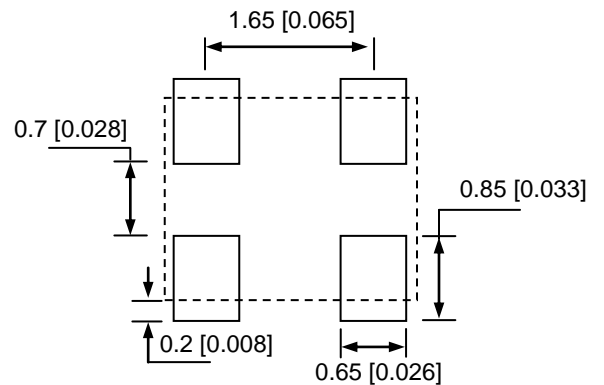

units: mm [inch]

Ordering Information

DSC1001 PTS – xxx.xxxx T

PART NUMBERING GUIDE				
Package (Plastic QFN)	Temperature	Stability	Frequency	Packing Option
P=A: 7.0x5.0mm P=B: 5.0x3.2mm P=C: 3.2x2.5mm P=D: 2.5x2.0mm	T=C: 0° ~ +70° C T=E: -20° ~ +70° C T=I: -40° ~ +85° C T=L: -40° ~ +105° C	S=1: ±50ppm S=2: ±25ppm S=5: ±10ppm	XXX.XXXX	Blank: Tubes T: Tape & Reel

Example: DSC1001CE1-123.0000T

The example part number above is a 123.0000MHz oscillator in Plastic 3.2x2.5mm package, with ±50ppm stability over an operating temperature of -20 to +70°C, shipped in Tape and Reel.

Disclaimer:

Discera makes no warranty of any kind, express or implied, with regard to this material, including, but not limited to, the implied warranties of merchantability and fitness for a particular purpose. Discera reserves the right to make changes without further notice to materials described herein. Discera does not assume any liability arising from the application or use of any product or circuit described herein. Discera does not authorize its products for use a critical components in life-support systems where a malfunction or failure may reasonably be expected to result in significant injury to the user. The inclusion of Discera's product in a life-support systems application implies that the manufacturer assumes all risk of such use and in doing so indemnifies Discera against all charges.

X-ON Electronics

Largest Supplier of Electrical and Electronic Components

Click to view similar products for [Standard Clock Oscillators](#) category:

Click to view products by [Microchip](#) manufacturer:

Other Similar products are found below :

[601252](#) [F335-12](#) [F335-25](#) [F535L-33.333](#) [F535L-50](#) [ASV-20.000MHZ-LR-T](#) [ECS-2018-160-BN-TR](#) [EL13C7-H2F-125.00M](#) [MXO45HS-2C-66.6666MHZ](#) [SiT8209AI-32-33E-125.000000](#) [SM4420TEV-40.0M-T1K](#) [F335-24](#) [F335-40](#) [F535L-10](#) [F535L-12](#) [F535L-16](#) [F535L-24](#) [F535L-27](#) [F535L-48](#) [PE7744DW-100.0M](#) [CSX-750FCC14745600T](#) [ASF1-3.686MHZ-N-K-S](#) [XO57CTECNA3M6864](#) [ECS-2100A-147.4](#) [601251](#) [EP16E7E2H26.000MTR](#) [SIT8918AA-11-33S-16.000000G](#) [XO3003](#) [9120AC-2D2-33E212.500000](#) [9102AI-243N25E100.00000](#) [8208AC-82-18E-25.00000](#) [ASDK2-32.768KHZ-LR-T3](#) [8008AI-72-XXE-24.545454E](#) [8004AC-13-33E-133.33000X](#) [AS-4.9152-16-SMD-TR](#) [ASFL1-48.000MHZ-LC-T](#) [SIT8920AM-31-33E-25.0000](#) [DSC1028DI2-019.2000](#) [9121AC-2C3-25E100.00000](#) [9102AI-233N33E100.00000X](#) [9102AI-233N25E200.00000](#) [9102AI-232H25S125.00000](#) [9102AI-133N25E200.00000](#) [9102AC-283N25E200.00000](#) [9001AC-33-33E1-30.000](#) [XLH536125.000JS4I](#) [3921AI-2CF-33NZ125.000000](#) [5730-1SF](#) [PXA000010](#) [SIT1602BC-83-33E-10.000000Y](#)