



Crystal-less™ Four Output PCIe Clock Generator

General Description

The DSC557-05 is a Crystal-less™, four output PCI express clock generator meeting Gen1, Gen2, and Gen3 specifications. The clock generator uses proven silicon MEMS technology to provide excellent jitter and stability over a wide range of supply voltages and temperatures. By eliminating the external quartz crystal, MEMS clock generators significantly enhance reliability and accelerate product development, while meeting stringent clock performance criteria for a variety of communications, storage, and networking applications.

DSC557-05 has an Output Enable / Disable feature allowing it to disable all outputs when OE1 and OE2 are low. Each output enable pin controls two banks of synchronous PCIe clocks. See the OE function diagram for more detail. The device is available in a 20 pin QFN. Additional output formats are in any combination of LVPECL, LVDS, and HCSL.

Block Diagram

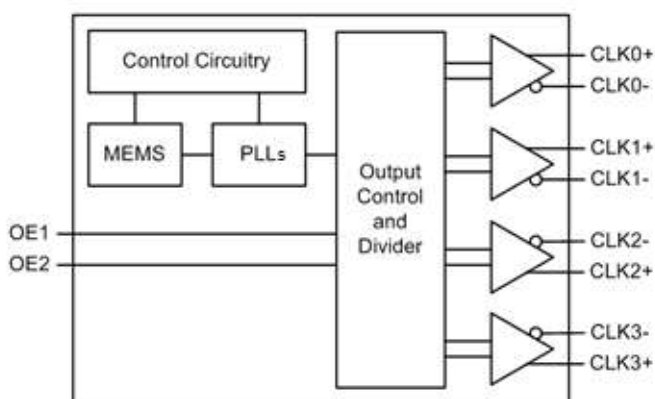

* CLK0+/-, Clk1+/-, Clk2 +/- and Clk3 +/- are 100 MHz as per PCIe standards. For other frequencies, please contact the factory.

Features

- **Meets PCIe Gen1, Gen2 & Gen3 specs**
- **Available Output Formats:**
 - HCSL, LVPECL, or LVDS
 - Mixed Outputs: LVPECL/HCSL/LVDS
- **Wide Temperature Range**
 - Ext. Industrial: -40° to 105° C
 - Industrial: -40° to 85° C
 - Ext. commercial: -20° to 70° C
- **Supply Range of 2.25 to 3.6 V**
- **Low Power Consumption**
 - 30% lower than competing devices
- **Excellent Shock & Vibration Immunity**
 - Qualified to MIL-STD-883
- **Available Footprints:**
 - 20 QFN
- **Lead Free & RoHS Compliant**
- **Short Lead Time: 2 Weeks**

Applications

- **Communications/Networking**
 - Ethernet
 - 1G, 10GBASE-T/KR/LR/SR, and FcoE
 - Routers and Switches
 - Gateways, VoIP, Wireless AP's
 - Passive Optical Networks
- **Storage**
 - SAN, NAS, SSD, JBOD
- **Embedded Applications**
 - Industrial, Medical, and Avionics
 - Security Systems and Office Automation
 - Digital Signage, POS and others
- **Consumer Electronics**
 - Smart TV, Bluray, STB

Specifications (Unless specified otherwise: T=25° C, VDD =3.3V)

Parameter		Condition	Min.	Typ.	Max.	Unit
Supply Voltage ¹	V _{DD}		2.25		3.6	V
Supply Current	I _{DD}	EN pin low – outputs are disabled		42	46	mA
Supply Current ² (Four HCSL Outputs)	I _{DD}	EN pin high – outputs are enabled R _L =50 Ω, F _{O1} =F _{O2} =F _{O3} = F _{O4} =100 MHz		120		mA
Frequency Stability	Δf	Includes frequency variations due to initial tolerance, temp. and power supply voltage			±100	ppm
					±50	
Startup Time ³	t _{SU}	T=25°C			5	ms
Input Logic Levels Input logic high Input logic low	V _{IH}		0.75xV _{DD} -		-	V
	V _{IL}			0.25xV _{DD}		
Output Disable Time ⁴	t _{DA}				5	ns
Output Enable Time	t _{EN}				20	ns
Pull-Up Resistor ²		Pull-up on OE pin		40		kΩ

HCSL Outputs ⁶						
Parameter		Condition	Min.	Typ.	Max.	Unit
Output Logic Levels Output logic high Output logic low	V _{OH}	R _L =50Ω	0.725 -		-	V
	V _{OL}			0.1		
Pk to Pk Output Swing		Single-Ended		750		mV
Output Transition time ⁴ Rise Time Fall Time	t _R	20% to 80% R _L =50Ω, C _L = 2pF	200		400	ps
	t _F					
Frequency	f ₀	Single Frequency	2.3	100 ⁷	460	MHz
Output Duty Cycle	SYM	Differential	48		52	%
Period Jitter ⁵	J _{PER}	F _{O1} =F _{O2} = F _{O3} = F _{O4} =100 MHz		2.5		ps _{RMS}
Jitter, Phase (Common Clock Architecture)	T _J	PCIe Gen 1.1		22.7	86.0 ⁸	ps _{p-p}
	J _{RMS-CCHF}	PCIe Gen 2.1, 1.5MHz to Nyquist		2.20	3.1 ⁸	ps _{RMS}
	J _{RMS-CCLF}	PCIe Gen 2.1, 10 kHz to 1.5 MHz		0.08	3.0 ⁸	ps _{RMS}
	J _{RMS-CC}	PCIe Gen 3.0		0.37	1.0 ⁸	ps _{RMS}
Integrated Phase Noise (Data Clock Architecture)	J _{RMS-DCHF}	PCIe Gen 2.1, 1.5MHz to Nyquist		2.15	4.0 ⁸	ps _{RMS}
	J _{RMS-DCLF}	PCIe Gen 2.1, 10 kHz to 1.5 MHz		0.06	7.5 ⁸	ps _{RMS}
	J _{RMS-DC}	PCIe Gen 3.0		0.32	1.0 ⁸	ps _{RMS}

Notes:

- Each V_{DD} pin should be filtered with 0.01uf capacitor.
- Output is enabled if OE pin is floated or not connected.
- t_{SU} is time to 100PPM stable output frequency after V_{DD} is applied and outputs are enabled.
- Output Waveform and Connection Diagram define the parameters.
- Period Jitter includes crosstalk from adjacent output.
- Contact Sales@Discera.com for alternate output options (LVPECL, LVDS, LVCMOS).
- Contact Sales@Discera.com for alternative frequency options
- Jitter limits established by Gen 1.1, Gen 2.1, and Gen 3.0 PCIe standards.

Absolute Maximum Ratings

Item	Min	Max	Unit	Condition
Supply Voltage	-0.3	+4.0	V	
Input Voltage	-0.3	$V_{DD}+0.3$	V	
Junction Temp	-	+150	°C	
Storage Temp	-55	+150	°C	
Soldering Temp	-	+260	°C	40sec max.
ESD	-		V	
HBM		4000		
MM		400		
CDM		1500		

Solder Reflow Profile

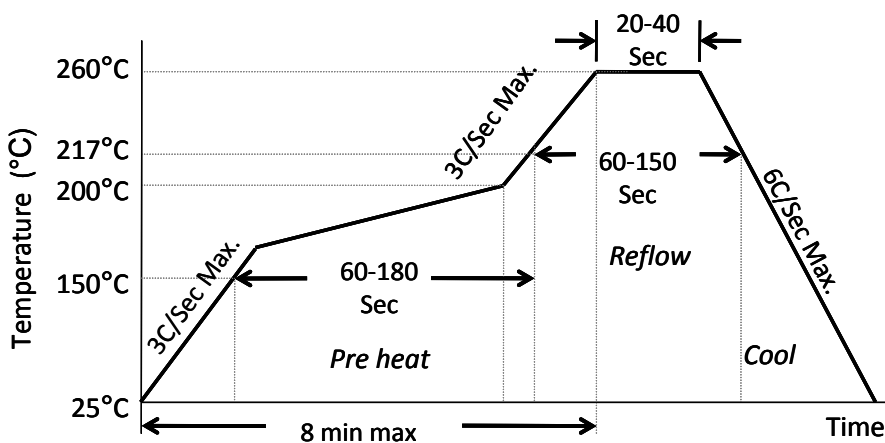

20 QFN MSL 1 @ 260°C refer to JSTD-020C	
Ramp-Up Rate (200°C to Peak Temp)	3°C/Sec Max.
Preheat Time 150°C to 200°C	60-180 Sec
Time maintained above 217°C	60-150 Sec
Peak Temperature	255-260°C
Time within 5°C of actual Peak	20-40 Sec
Ramp-Down Rate	6°C/Sec Max.
Time 25°C to Peak Temperature	8 min Max.

Pin Description (20 QFN)

Pin No.	Pin Name	Pin Type	Description
1	OE1	I	Output Enable; active high
2	NC	NA	Leave unconnected or grounded
3	VSS	Power	Ground
4	VSS	Power	Ground
5	CLK0-	O	Complement output of differential pair
6	CLK0+	O	True output of differential pair
7	CLK1-	O	Complement output of differential pair
8	CLK1+	O	True output of differential pair
9	VDD	Power	Power Supply
10	NC	NA	Leave unconnected or grounded
11	OE2	I	Output Enable; active high
12	NC	NA	Leave unconnected or grounded
13	VSS	Power	Ground
14	VSS	Power	Ground
15	CLK2-	O	Complement output of differential pair
16	CLK2+	O	True output of differential pair
17	CLK3-	O	Complement output of differential pair
18	CLK3+	O	True output of differential pair
19	VDD	Power	Power Supply
20	NC	NA	Leave unconnected or grounded

Pin Diagram (20 QFN)

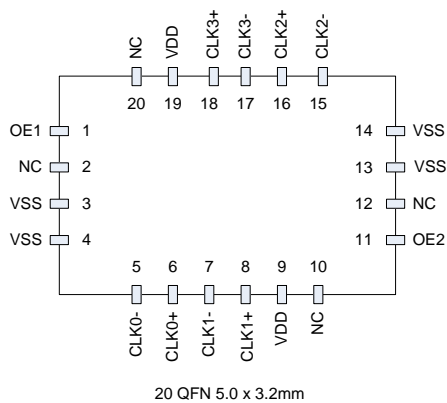

Connection Diagram

(20 QFN Four HCSL Outputs)

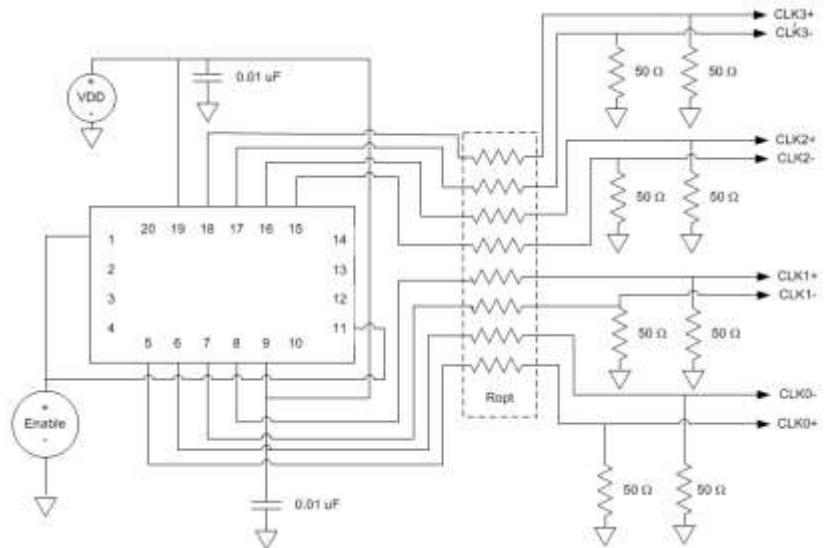

OE Function and Output Waveform: HCSL

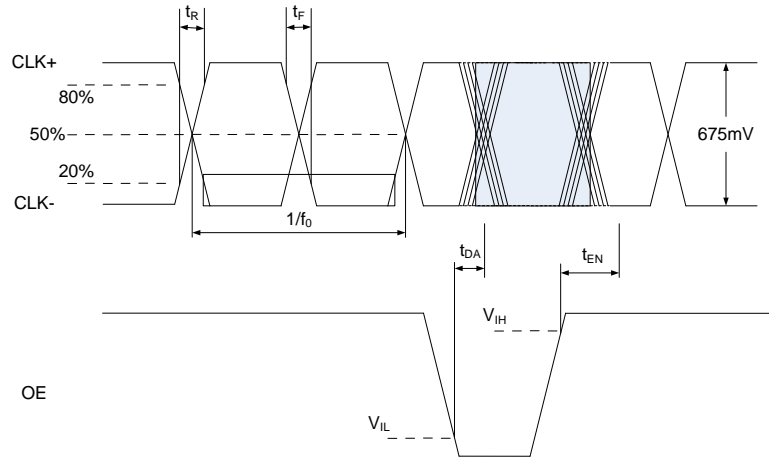

		CLK1/CLK2 Synchronous				
OE1	OE2	CLK0	CLK1	CLK2	CLK3	
0	0	Hi-Z	Hi-Z	Hi-Z	Hi-Z	
0	1	Hi-Z	EN	EN	Hi-Z	
1	0	EN	Hi-Z	Hi-Z	EN	
1	1	EN	EN	EN	EN	

CLK0/CLK3 Synchronous

Ordering Information

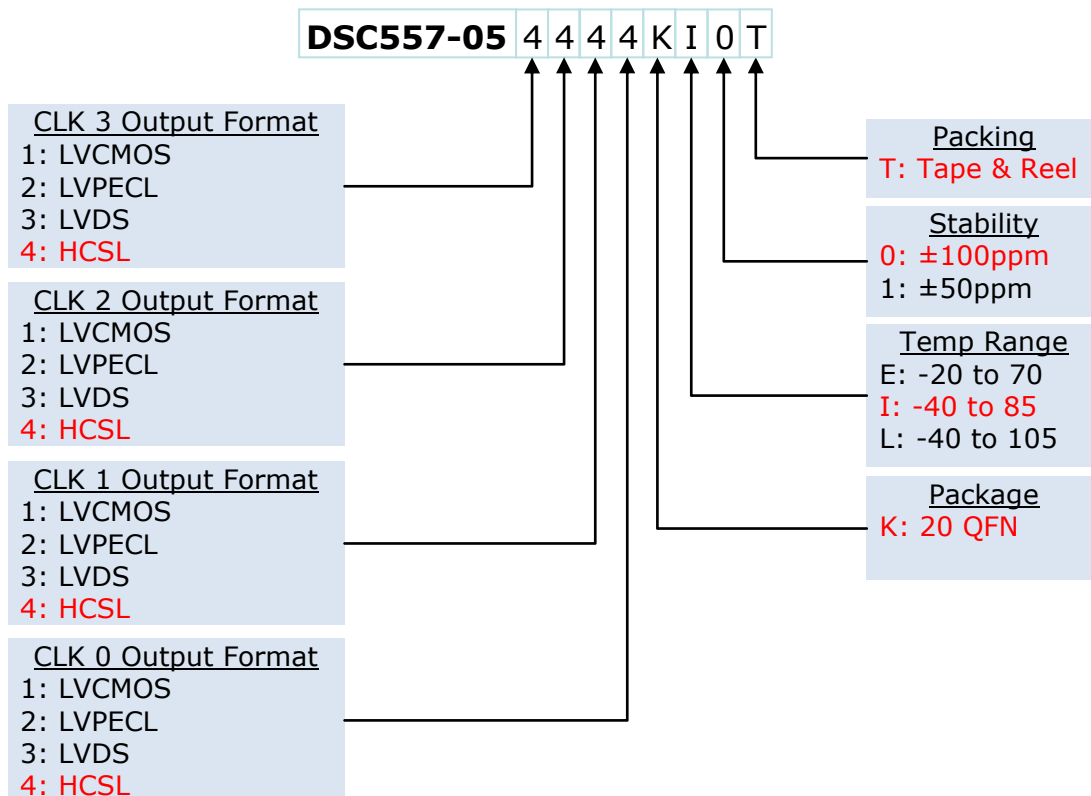

Package Dimensions

20 QFN, 5.0 x 3.2 mm

Top View units: mm[inches]

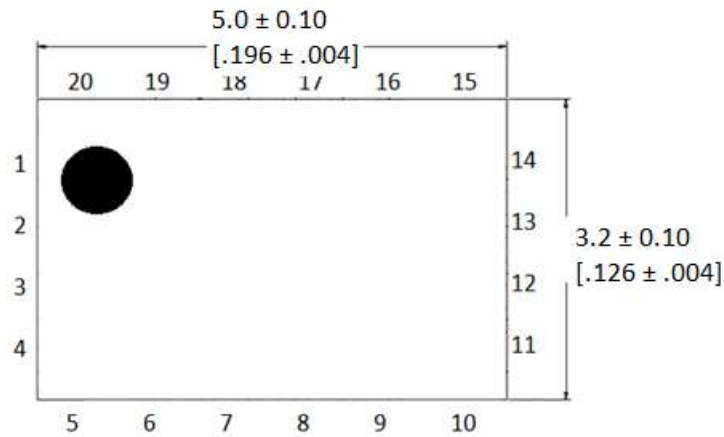

Bottom View units: mm[inches]±

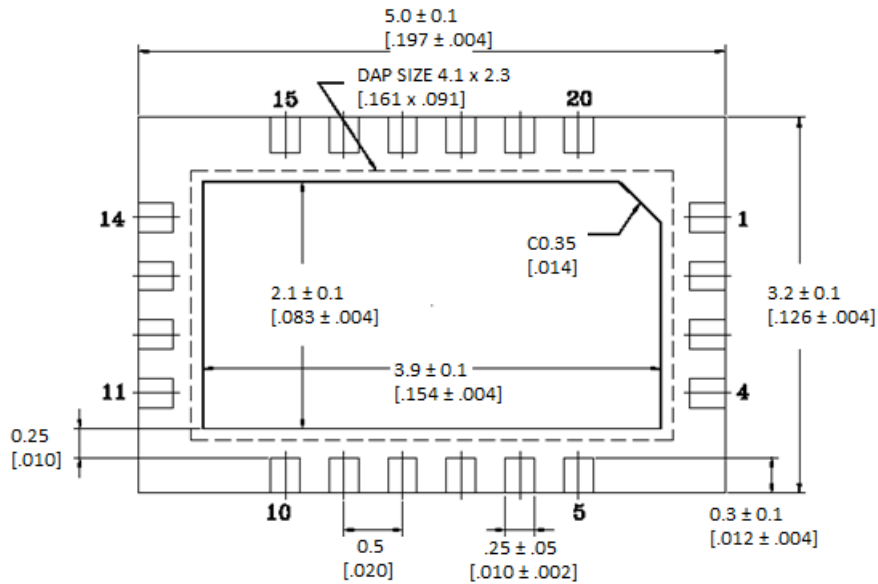

Side View
units: mm[inches]



Recommended Solder Pad Layout
units: mm[inches]

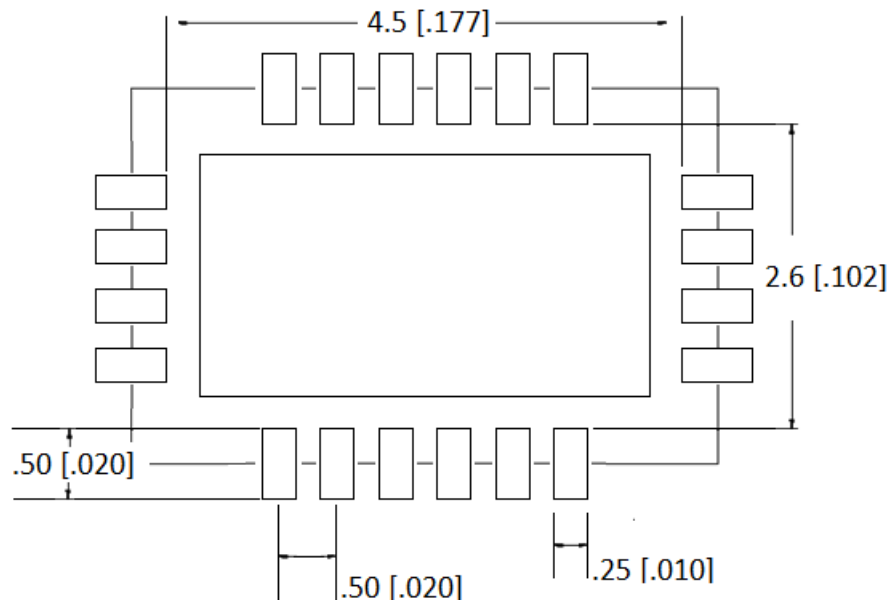

*Connect the center pad to VSS for best thermal performance

Disclaimer:

Micrel makes no representations or warranties with respect to the accuracy or completeness of the information furnished in this data sheet. This information is not intended as a warranty and Micrel does not assume responsibility for its use. Micrel reserves the right to change circuitry, specifications and descriptions at any time without notice. No license, whether express, implied, arising by estoppel or otherwise, to any intellectual property rights is granted by this document. Except as provided in Micrel's terms and conditions of sale for such products, Micrel assumes no liability whatsoever, and Micrel disclaims any express or implied warranty relating to the sale and/or use of Micrel products including liability or warranties relating to fitness for a particular purpose, merchantability, or infringement of any patent, copyright or other intellectual property right.

Micrel Products are not designed or authorized for use as components in life support appliances, devices or systems where malfunction of a product can reasonably be expected to result in personal injury. Life support devices or systems are devices or systems that (a) are intended for surgical implant into the body or (b) support or sustain life, and whose failure to perform can be reasonably expected to result in a significant injury to the user. A Purchaser's use or sale of Micrel Products for use in life support appliances, devices or systems is a Purchaser's own risk and Purchaser agrees to fully indemnify Micrel for any damages resulting from such use or sale.

X-ON Electronics

Largest Supplier of Electrical and Electronic Components

Click to view similar products for [Clock Generators & Support Products](#) category:

Click to view products by [Microchip](#) manufacturer:

Other Similar products are found below :

[5P49V5901A748NLGI](#) [5P49V5901B680NLGI](#) [5P49V5901B744NLGI](#) [5P49V5929B502NLGI](#) [5P49V5935B520LTGI](#) [5V49EE903-116NLGI](#)
[CV183-2TPAG](#) [82P33814ANLG/W](#) [8T49N004A-002NLGI](#) [8T49N004A-039NLGI](#) [9FGV0631CKLF](#) [9FGV0641AKLFT](#) [9LRS3197AKLF](#)
[9UMS9633BFILF](#) [9VRS4450AKLF](#) [NB3N51132DTR2G](#) [8N3Q001EG-0035CDI](#) [932SQ426AKLF](#) [950810CGLF](#) [9DBV0531AKILF](#)
[9DBV0741AKILF](#) [9FGV0641AKLF](#) [9UMS9633BKLF](#) [9VRS4420DKILF](#) [9VRS4420DKLF](#) [9VRS4420DKLFT](#) [CY25404ZXI226](#)
[CY25422SXI-004](#) [5P49V5901B712NLGI](#) [NB3H5150-01MNTXG](#) [6INT61041NDG](#) [PL602-20-K52TC](#) [PL613-51QC](#) [8N3Q001FG-1114CDI](#)
[9FGV0641AKILF](#) [ZL30314GKG2](#) [ZL30253LDG1](#) [ZL30251LDG1](#) [ZL30250LDG1](#) [ZL30169LDG1](#) [ZL30142GGG2](#) [9UMS9633BKILFT](#)
[9FGV0631CKLFT](#) [9FGV0631CKILF](#) [5P49V5935B536LTGI](#) [PI6LC48P0101LIE](#) [DS1099U-ST+](#) [MAX24305EXG+](#) [PI6LC48H02-01LIE](#)
[82P33814ANLG](#)