



General Description

The DSC8001 is a programmable silicon MEMS based CMOS oscillator offering excellent jitter and stability performance over a wide range of supply voltages and temperatures. The device operates from 1 to 150MHz in increments of 100Hz (up to four decimal point resolution) with supply voltages between 1.8 to 3.3 Volts and extended temperatures from -40°C to 105°C.

The DSC8001 incorporates an all silicon resonator that is extremely robust and nearly immune to stress related fractures, common to crystal based oscillators. Without sacrificing the performance and stability required of today's systems, a crystal-less design allows for a higher level of reliability, making the DSC8001 ideal for rugged, industrial, and portable applications where stress, shock, and vibration can damage quartz crystal based systems.

Available in industry standard packages, the DSC8001 can be "dropped-in" to the same PCB footprint as standard crystal oscillators.

Block Diagram

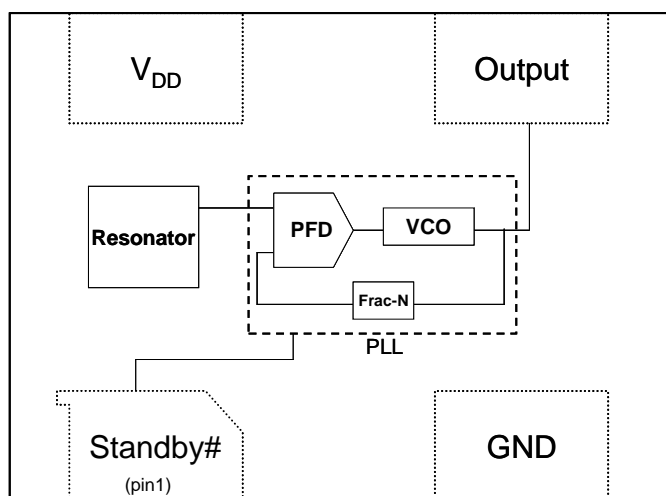

Features

- Frequency Range: 1 to 150MHz
- Exceptional Stability over Temperature
 - ±10 PPM, ±25 PPM, ±50 PPM
- Operating voltage
 - 1.7 to 3.6V
- Operating Temperature Range
 - Ext. Industrial -40°C to 105°C
 - Industrial -40°C to 85°C
 - Ext. Commercial -20°C to 70°C
 - Commercial 0°C to 70°C
- Low Operating and Standby Current
 - 5mA Operating (40MHz)
 - 15uA Standby
- Ultra Miniature Footprint
 - 2.5 x 2.0 x 0.85 mm
 - 3.2 x 2.5 x 0.85 mm
 - 5.0 x 3.2 x 0.85 mm
 - 7.0 x 5.0 x 0.85 mm
- MIL-STD 883 Shock and Vibration Resistant
- Pb Free, RoHS, Reach SVHC Compliant
- AEC-Q100 Reliability Qualified

Benefits

- Pin for pin "drop in" replacement for industry standard oscillators
- Semiconductor level reliability, significantly higher than quartz
- Frequency Resolution to 4 decimals
- Longer Battery Life / Reduced Power
- Compact Plastic package
- Cost Effective

Applications

- Mobile Applications
- Consumer Electronics
- Portable Electronics
- DVR, CCTV, Surveillance Cameras
- Low Profile Applications
- Industrial Applications

Absolute Maximum Ratings¹

Item	Min.	Max	Unit	Condition
Supply Voltage	-0.3	+4.0	V	
Input Voltage	-0.3	VDD+0.3	V	
Junction Temp	-	+150	°C	
Storage Temp	-55	+150	°C	
Soldering Temp	-	+260	°C	40 sec max.
ESD	-		V	
HBM		4000		
MM		200		
CDM		1500		

Ordering Code

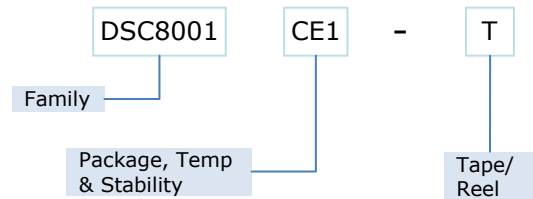

* See Ordering Information for details

Recommended Operating Conditions

Parameter	Symbol	Range
Supply Voltage	V _{DD}	1.71 – 3.60V
Output Load	Z _L	R>10KΩ, C≤15pF
Operating Temperature	T	-40 to +105 °C
Option 1		-40 to +85 °C
Option 2		-20 to +70 °C
Option 3		0 to +70 °C

Specifications (VDD = 1.8 to 3.3v) T_A=85°C unless otherwise specified

Parameter	Symbol	Condition	Min	Typ	Max	Unit
Frequency	f ₀	Single Frequency	1		150	MHz
Frequency Tolerance	Δf	Includes frequency variations due to initial tolerance, temperature and power supply voltage			±10,±25,±50	ppm
Aging	Δf	1 year @25°C			±5	ppm
Supply Current, standby	I _{DD}	T=25°C			15	uA
Output Logic Levels	V _{OH} V _{OL}	-4mA 4mA	0.8*V _{DD}		-	Volts
Output logic high			-		0.2*V _{DD}	
Output logic low						
Output Startup Time ²	t _{SU}	T=25°C		1.0	1.3	ms
Output Disable Time	t _{DA}			20	100	ns
Output Duty Cycle	SYM		45		55	%
Input Logic Levels	V _{IH} V _{IL}		0.75*V _{DD}		-	Volts
Input logic high			-		0.25* V _{DD}	
Input logic low						

VDD = 1.8v

Parameter	Symbol	Condition		Min	Typ	Max	Unit
Supply Current, no load	I_{DD}	$C_L=0p$ $R_L=\infty$ $T=25^\circ C$	1MHz		6.0	6.3	mA
			27MHz		6.5	6.9	
			70MHz		7.2	7.5	
			150MHz		8.3	9.1	
Output Transition time Rise Time Fall Time	t_R	$C_L=15pF; T=25^\circ C$ $20\%/80\%*V_{DD}$			1.8	3	ns
	t_F				1.0	3	
Jitter, Max Cycle to Cycle	J_{CC}	$F = 100MHz^3$			60		Ps

VDD = 2.5v

Parameter	Symbol	Condition		Min	Typ	Max	Unit
Supply Current, no load	I_{DD}	$C_L=0p$ $R_L=\infty$ $T=25^\circ C$	1MHz		6.0	6.3	mA
			27MHz		6.7	7.0	
			70MHz		7.7	8.1	
			150MHz		9.6	10.6	
Output Transition time Rise Time Fall Time	t_R	$C_L=15pF; T=25^\circ C$ $20\%/80\%*V_{DD}$			1.0	2	ns
	t_F				0.9	2	
Jitter, Max Cycle to Cycle	J_{CC}	$F = 100MHz^3$			50		ps

VDD = 3.3v

Parameter	Symbol	Condition		Min	Typ	Max	Unit
Supply Current, no load	I_{DD}	$C_L=0p$ $R_L=\infty$ $T=25^\circ C$	1MHz		6.0	6.3	mA
			27MHz		6.8	7.2	
			70MHz		8.2	8.7	
			150MHz		10.8	12.2	
Output Transition time Rise Time Fall Time	t_R	$C_L=15pF; T=25^\circ C$ $20\%/80\%*V_{DD}$			1.0	2	ns
	t_F				0.9	2	
Jitter, Max Cycle to Cycle	J_{CC}	$F = 100MHz^3$			50		ps

Notes:

1. Absolute maximum ratings are those values beyond which the safety of the device cannot be guaranteed. The device should not be operated beyond these limits.
2. t_{SU} is time to stable output frequency after V_{DD} is applied. t_{SU} and t_{EN} (after EN is asserted) are identical values.
3. Measured over 50k clock cycles.

Nominal Performance Characteristics

Supply Current

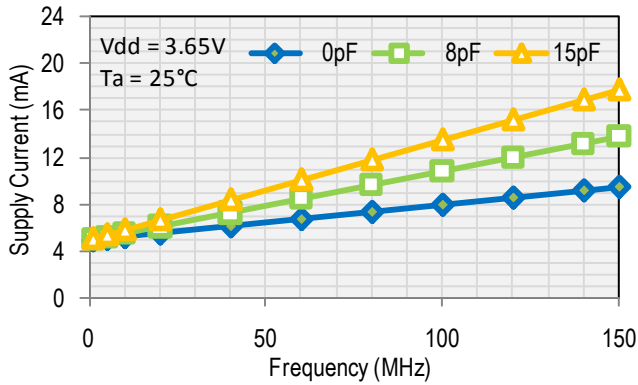

Supply Current

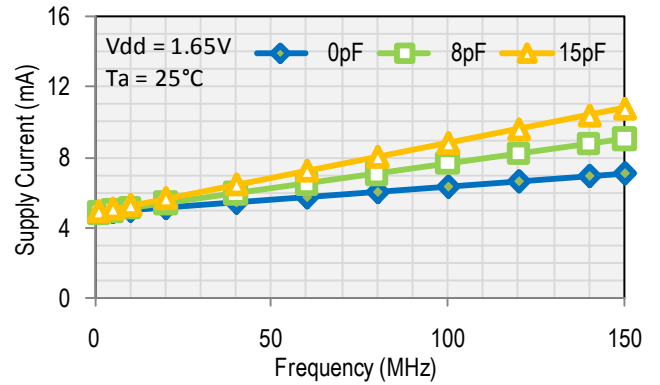

Rise Time

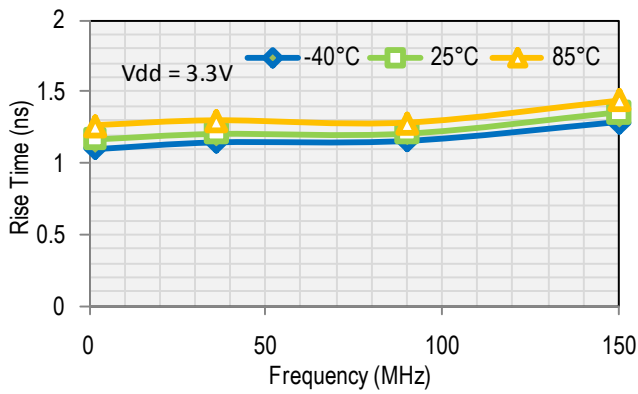

Fall Time

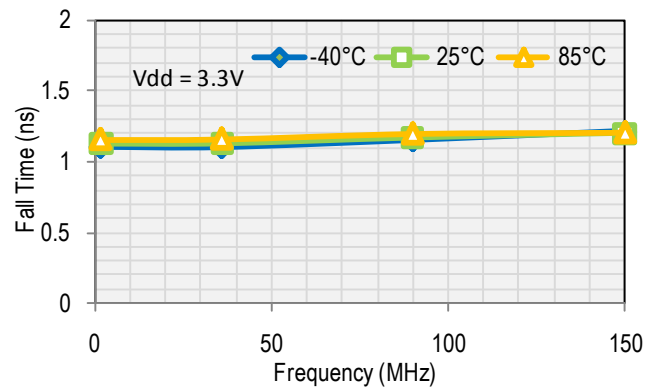

Rise Time

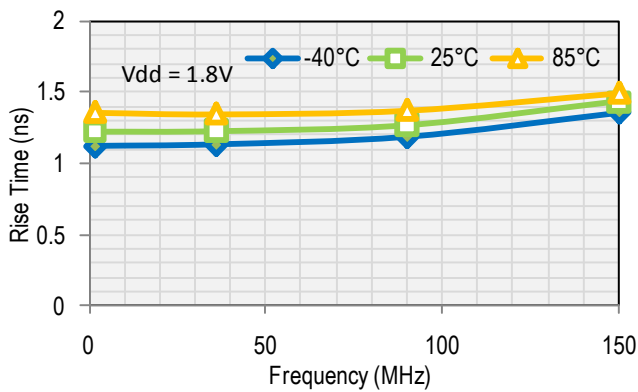

Fall Time

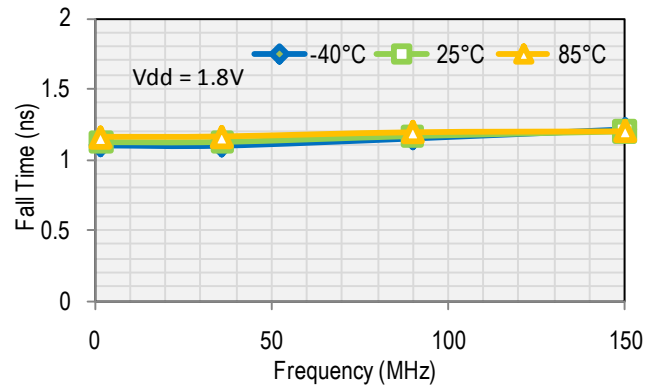

Output Waveform

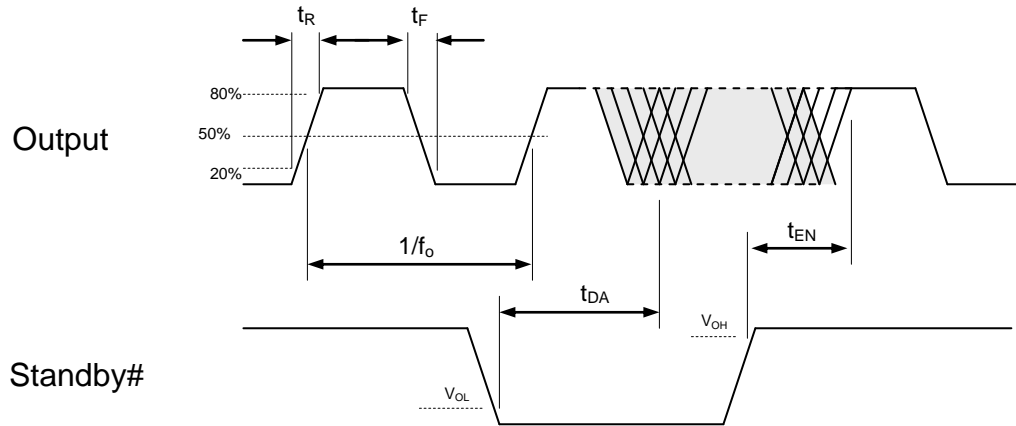

Standby Function

Standby# (pin 1)	Output (pin 3)
Hi Level	Output ON
Open (no connect)	Output ON
Low Level	High Impedance

Test Circuit

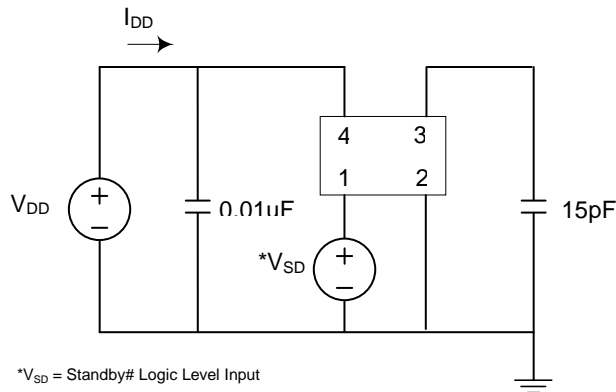

Board Layout (recommended)

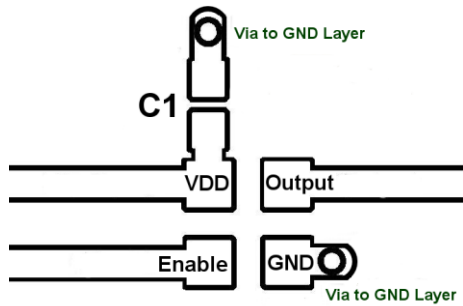

Solder Reflow Profile

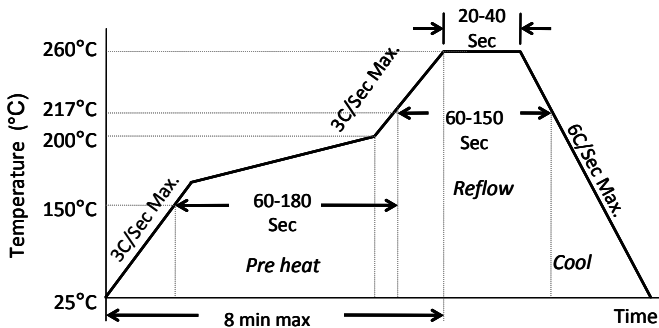

MSL 1 @ 260°C refer to JSTD-020C	
Ramp-Up Rate (200°C to Peak Temp)	3°C/Sec Max.
Preheat Time 150°C to 200°C	60-180 Sec
Time maintained above 217°C	60-150 Sec
Peak Temperature	255-260°C
Time within 5°C of actual Peak	20-40 Sec
Ramp-Down Rate	6°C/Sec Max.
Time 25°C to Peak Temperature	8 min Max.

Package Dimensions

7.0 x 5.0 mm Plastic Package

External Dimensions

7.0±0.10 [0.276±0.004]
#4 #3
#1 #2
5.0±0.10 [0.197±0.004]
2.6 [0.102]
3.5 [0.138]
2.2 [0.087]
0.2 [0.008]
1.4 [0.055]
#2 #1
0.2 [0.008]
1.2 [0.047]

Recommended Land Pattern*

5.08 [0.200]
2.6 [0.102]
0.2 [0.008]
1.4 [0.055]
0.2 [0.008]
1.4 [0.055]

No.	Pin Terminal
1	Standby#
2	GND
3	Output
4	VDD

units: mm [inch]

5.0 x 3.2 mm Plastic Package

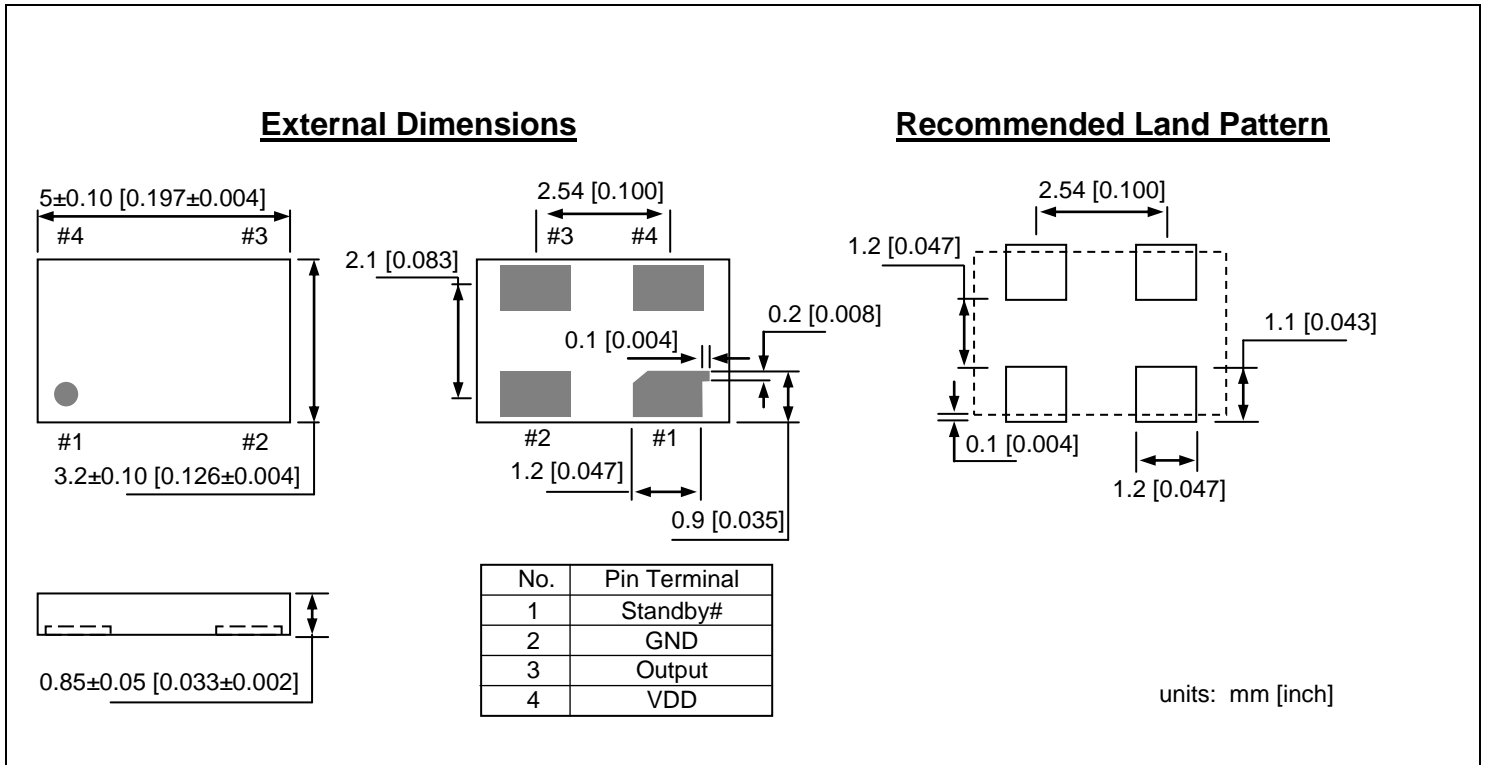

3.2 x 2.5 mm Plastic Package

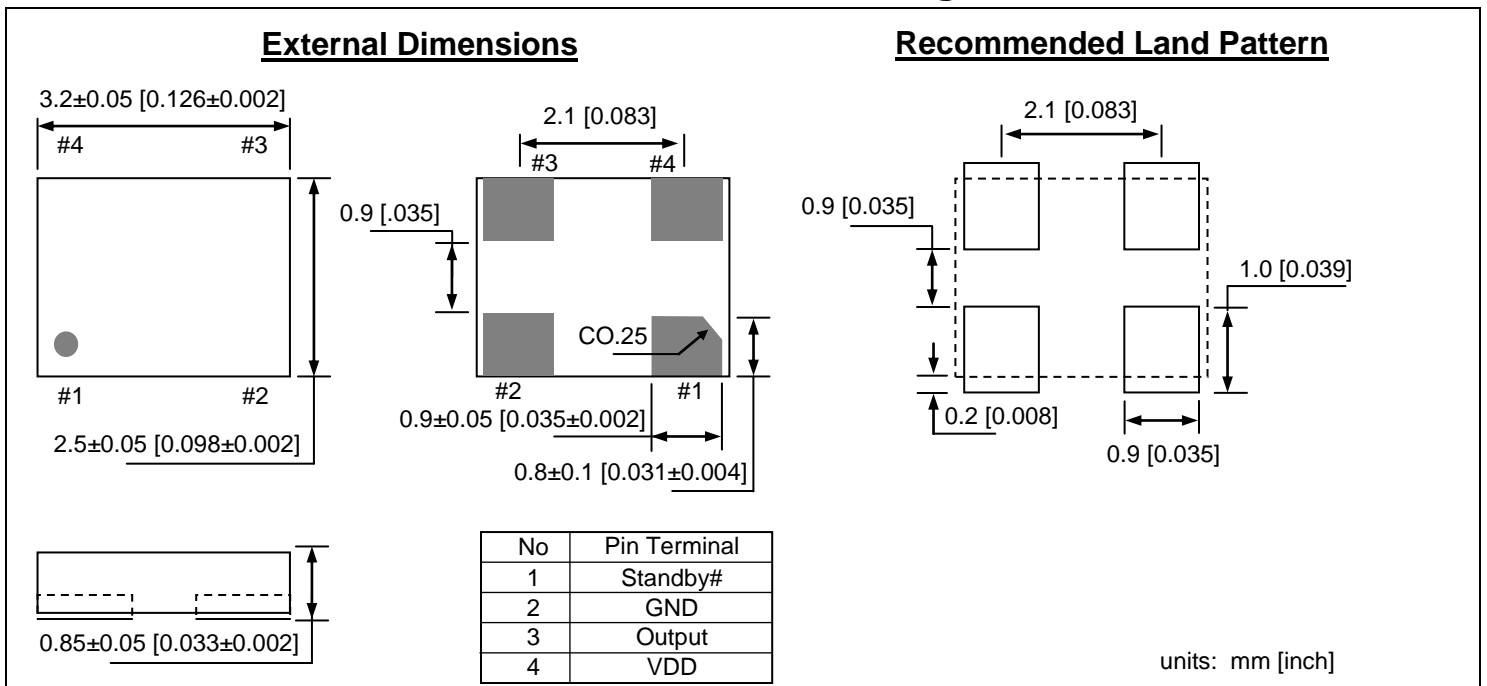

2.5 x 2.0 mm Plastic Package

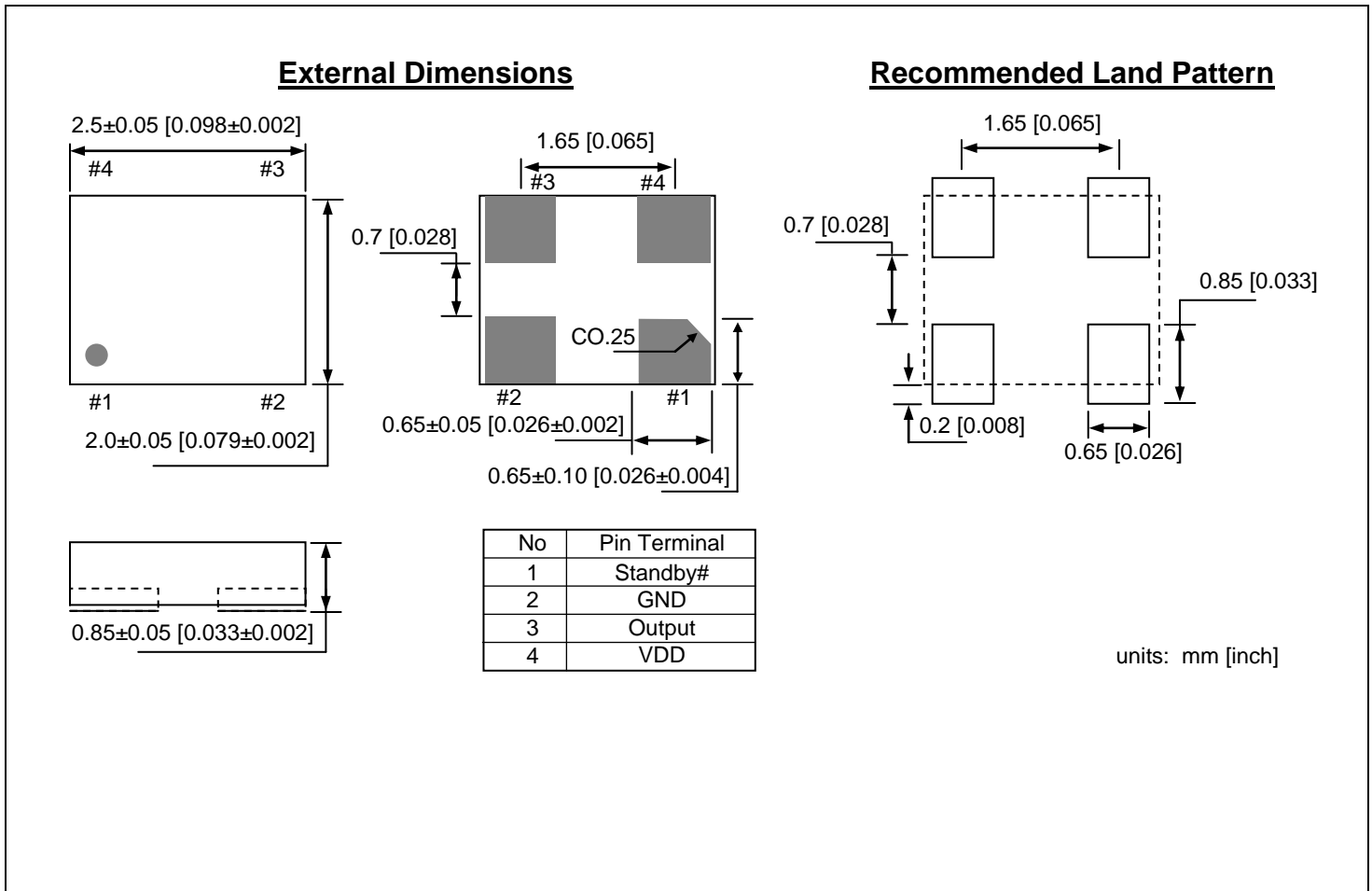

Ordering Information

DSC8001 PTS - T

PART NUMBERING GUIDE			
Package (Plastic QFN)	Temperature	Stability	Packing Option
P=A: 7.0x5.0mm P=B: 5.0x3.2mm P=C: 3.2x2.5mm P=D: 2.5x2.0mm	T=C: 0° ~ +70° C T=E: -20° ~ +70° C T=I: -40° ~ +85° C T=L: -40° ~ +105° C	S=1: ±50ppm S=2: ±25ppm S=5: ±10ppm	Blank: Tubes T: Tape & Reel

Disclaimer:

Micrel makes no representations or warranties with respect to the accuracy or completeness of the information furnished in this data sheet. This information is not intended as a warranty and Micrel does not assume responsibility for its use. Micrel reserves the right to change circuitry, specifications and descriptions at any time without notice. No license, whether express, implied, arising by estoppel or otherwise, to any intellectual property rights is granted by this document. Except as provided in Micrel's terms and conditions of sale for such products, Micrel assumes no liability whatsoever, and Micrel disclaims any express or implied warranty relating to the sale and/or use of Micrel products including liability or warranties relating to fitness for a particular purpose, merchantability, or infringement of any patent, copyright or other intellectual property right.

MICREL, Inc. • **2180 Fortune Drive,** • **San Jose, California** • **95131** • **USA**
Phone: +1 (408) 944-0800 • **Fax: +1 (408) 474-1000** • **Email: hbwhelp@micrel.com** • **www.micrel.com**

X-ON Electronics

Largest Supplier of Electrical and Electronic Components

Click to view similar products for [Programmable Oscillators](#) category:

Click to view products by [Microchip](#) manufacturer:

Other Similar products are found below :

[8N4Q001LG-0102CDI](#) [8N4Q001LG-0139CDI](#) [8N4Q001LG-0055CDI](#) [DSC8121CI1](#) [DSC8102DI2](#) [DSC8124CI2](#) [DSC8121CL5](#) [ECS-P143-10-AN](#) [SG-8002CA](#) [2.4576M-PCBB](#) [ECS-3525-250-B-TR](#) [DSC6013JI1A-000.0000](#) [DSC6013HI1A-002.5000T](#) [DSC6011JE2A-000.0000](#) [DSC6011HI1A-002.5000T](#) [DSC6083HE1A-032K800T](#) [DSC6001JI1A-000.0000](#) [DSC6001CI1A-011.0592](#) [SIT8008BI-22-33E-8.000000G](#) [DSC8002CI2](#) [AD2S99APZ](#) [AD2S99BPZ](#) [LTC6903HMS8#PBF](#) [LTC6903IMS8#PBF](#) [LTC6991CDCB#TRMPBF](#) [SG-8018CB](#) [98.304MTJHPA](#) [DS1086LU+C66](#) [DS1090U-2/V+T](#) [DSC2211FL2-E0016](#) [DSC6083CI1A-010K000](#) [DSC6011CI2A-018.0000](#) [DSC6001CI1A-016.9344T](#) [DSC6001CI1A-016.3690T](#) [DSC6001CE2A-025.0000](#) [DSC6001CI1A-016.3690](#) [DSC6051CE2A-003.0720](#) [DSC6083CI1A-350K000](#) [DSC6053CE2A-003.0720](#) [DSC6083CI1A-350K000T](#) [DSC6011CI2A-007.3728T](#) [DSC6011CI1A-013.5600](#) [DSC6083CI1A-425K000](#) [DSC6053CE2A-003.0720T](#) [DSC6051CE2A-003.0720T](#) [DSC6083CI1A-425K000T](#) [DSC6083CI1A-010K000T](#) [DSC6001CI1A-003.6864](#) [DSC6001CI1A-011.2896T](#) [DSC6001CI1A-012.0000](#) [DSC6001CI2A-004.0000T](#) [DSC6001CI2A-032.7680](#)