



# dsPIC33CK256MP508 FAMILY

---

## 28/36/48/64/80-Pin Digital Signal Controllers with High-Resolution PWM and CAN Flexible Data (CAN FD)

---

### Operating Conditions

- 3.0V to 3.6V, -40°C to +125°C, DC to 100 MIPS
- 3.0V to 3.6V, -40°C to +150°C, DC to 70 MIPS

### Core: 16-Bit dsPIC33CK CPU

- 32-256 Kbytes of Program Flash with ECC and 8-24K RAM
- Fast 6-Cycle Divide
- LiveUpdate
- Code Efficient (C and Assembly) Architecture
- 40-Bit Wide Accumulators
- Single-Cycle (MAC/MPY) with Dual Data Fetch
- Single-Cycle, Mixed-Sign MUL Plus Hardware Divide
- 32-Bit Multiply Support
- Four Sets of Interrupt Context Saving Registers which Include Accumulator and STATUS for Fast Interrupt Handling
- Zero Overhead Looping
- RAM Memory Built-In Self-Test (MBIST)

### Clock Management

- Internal Oscillator
- Programmable PLLs and Oscillator Clock Sources
- Reference Clock Output
- Fail-Safe Clock Monitor (FSCM)
- Fast Wake-up and Start-up
- Backup Internal Oscillator

### Power Management

- Low-Power Management Modes (Sleep, Idle, Doze)
- Integrated Power-on Reset and Brown-out Reset

### High-Speed PWM

- Eight PWM Pairs
- Up to 250 ps PWM Resolution
- Dead Time for Rising and Falling Edges
- Dead-Time Compensation
- Clock Chopping for High-Frequency Operation
- PWM Support for:
  - DC/DC, AC/DC, inverters, PFC, lighting
  - BLDC, PMSM, ACIM, SRM motors
- Fault and Current Limit Inputs
- Flexible Trigger Configuration for ADC Triggering

### Timers/Output Compare/Input Capture

- One General Purpose Timer
- Peripheral Trigger Generator (PTG):
  - Up to 15 trigger sources to other peripheral modules
  - CPU independent state machine-based instruction sequencer
- Nine MCCP/SCCP modules which Include Timer, Capture/Compare and PWM:
  - One MCCP
  - Eight SCCPs
  - 16 or 32-bit time base
  - 16 or 32-bit capture
  - 4-deep capture buffer
- Fully Asynchronous Operation, Available in Sleep Modes

# dsPIC33CK256MP508 FAMILY

---

## Advanced Analog Features

- High-Speed ADC module:
  - 12-bit with two dedicated SAR ADC cores and one shared SAR ADC core
  - Configurable resolution (up to 12-bit) for each ADC core
  - Up to 3.5 Msps conversion rate per channel at 12-bit resolution
  - Up to 24 input channels
  - Dedicated result buffer for each analog channel
  - Flexible and independent ADC trigger sources
  - Four digital comparators
  - Four oversampling filters for increased resolution
- Up to Three Analog Comparators:
  - 15 ns analog comparator
- Up to Three Op Amps
- Three 12-Bit DACs:
  - Hardware slope compensation

## Communication Interfaces

- Three Protocol UARTs with Automated Protocol Handling Support for:
  - LIN 2.2
  - DMX
  - IrDA®
- 3 Four-Wire SPI/I<sup>2</sup>S modules
- CAN Flexible Data (FD) module
- Three I<sup>2</sup>C modules with SMBus Support
- PPS to Allow Function Remap
- Programmable Cyclic Redundancy Check (CRC)
- Two SENT modules
- Parallel Master Port (PMP)

## Direct Memory Access (DMA)

- Four DMA Channels

## Debugger Development Support

- In-Circuit and In-Application Programming and Debugging
- Three Complex, Five Simple Breakpoints
- IEEE 1149.2 Compatible (JTAG) Boundary Scan
- Trace Buffer and Run-Time Watch

## Safety Features

- Clock Monitor System with Backup Oscillator
- DMT (Deadman Timer)
- ECC (Error Correcting Code)
- WDT (Watchdog Timer)
- CodeGuard™ Security
- CRC (Cyclic Redundancy Check)
- Flash OTP by ICSP™ Write Inhibit
- RAM Memory Built-In Self-Test (MBIST)
- Two-Speed Start-up
- Fail-Safe Clock Monitoring (FSCM)
- Backup FRC (BFRC)
- Capless Internal Voltage Regulator
- Virtual Pins for Redundancy and Monitoring

## Functional Safety Readiness – ISO 26262/ IEC 61508/IEC 60730

- To learn about the Functional Safety Readiness of this device family and various Functional Safety standards an application can target using this device family, visit [www.microchip.com/dsPIC33-Functional-Safety](http://www.microchip.com/dsPIC33-Functional-Safety)

## Qualification Support

- AEC-Q100 REV-H (Grade 1: -40°C to +125°C) Compliant
- AEC-Q100 REV-H (Grade 0: -40°C to +150°C) Compliant

## dsPIC33CK256MP508 PRODUCT FAMILIES

The device names, pin counts, memory sizes and peripheral availability of each device are listed in [Table 1](#) and [Table 2](#). The following pages show their pinout diagrams.

**TABLE 1: dsPIC33CK256MP508 FAMILY WITH CAN FD**

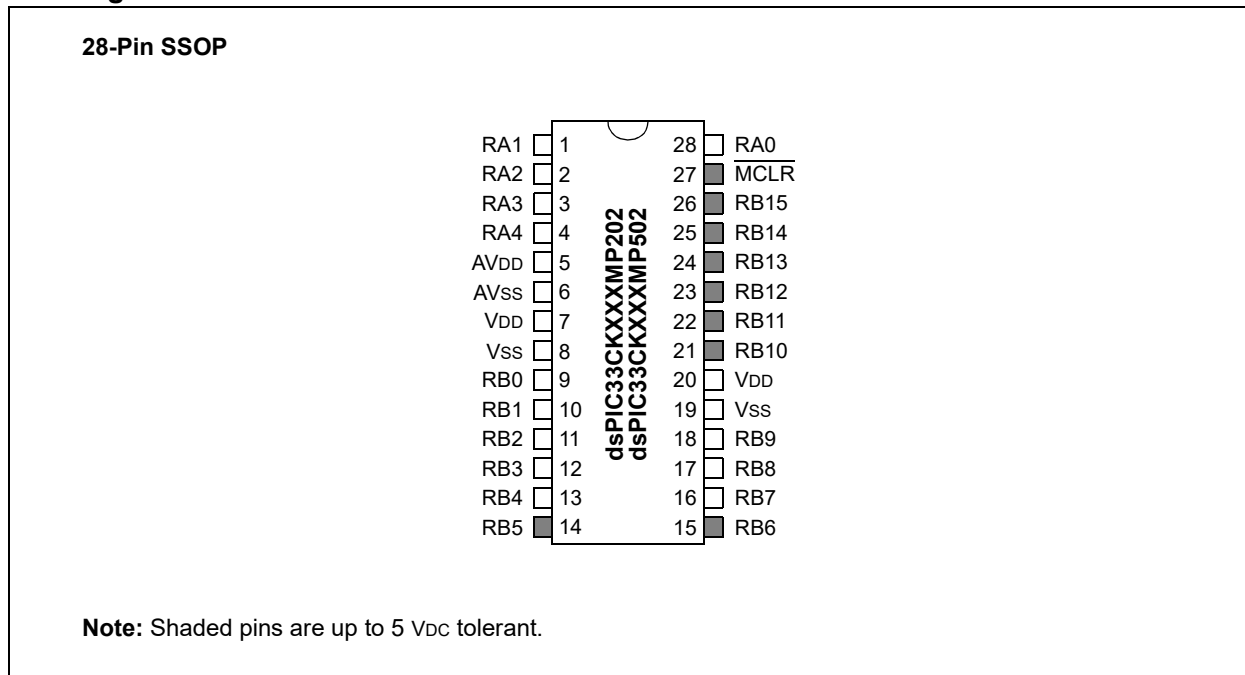
Product	Pins	Flash	Data RAM	ADC Module	ADC Channels	Timers	MCCP/S CCP	CAN FD	DMA Channels	SENT	UART	SPI	I <sup>2</sup> C	QEI	CLC	PTG	CRC	PWM Outputs	Analog Comparators	12-Bit DAC	Op Amp	PMP	REFO Clock
dsPIC33CK256MP508	80	256K	24K	3	24	1	1/8	1	4	2	3	3	3	2	4	1	1	8x2	3	3	3	1	1
dsPIC33CK256MP506	64	256K	24K	3	20	1	1/8	1	4	2	3	3	3	2	4	1	1	8x2	3	3	3	1	1
dsPIC33CK256MP505	48	256K	24K	3	19	1	1/8	1	4	2	3	3	3	2	4	1	1	8x2	3	3	3	0	1
dsPIC33CK256MP503	36	256K	24K	3	16	1	1/8	1	4	2	3	3	3	2	4	1	1	6x2	3	3	3	0	1
dsPIC33CK256MP502	28	256K	24K	3	12	1	1/8	1	4	2	3	3	3	2	4	1	1	4x2	3	3	2	0	1
dsPIC33CK128MP508	80	128K	16K	3	24	1	1/8	1	4	2	3	3	3	2	4	1	1	8x2	3	3	3	1	1
dsPIC33CK128MP506	64	128K	16K	3	20	1	1/8	1	4	2	3	3	3	2	4	1	1	8x2	3	3	3	1	1
dsPIC33CK128MP505	48	128K	16K	3	19	1	1/8	1	4	2	3	3	3	2	4	1	1	8x2	3	3	3	0	1
dsPIC33CK128MP503	36	128K	16K	3	16	1	1/8	1	4	2	3	3	3	2	4	1	1	6x2	3	3	3	0	1
dsPIC33CK128MP502	28	128K	16K	3	12	1	1/8	1	4	2	3	3	3	2	4	1	1	4x2	3	3	2	0	1
dsPIC33CK64MP508	80	64K	8K	3	24	1	1/8	1	4	2	3	3	3	2	4	1	1	8x2	3	3	3	1	1
dsPIC33CK64MP506	64	64K	8K	3	20	1	1/8	1	4	2	3	3	3	2	4	1	1	8x2	3	3	3	1	1
dsPIC33CK64MP505	48	64K	8K	3	19	1	1/8	1	4	2	3	3	3	2	4	1	1	8x2	3	3	3	0	1
dsPIC33CK64MP503	36	64K	8K	3	16	1	1/8	1	4	2	3	3	3	2	4	1	1	6x2	3	3	3	0	1
dsPIC33CK64MP502	28	64K	8K	3	12	1	1/8	1	4	2	3	3	3	2	4	1	1	4x2	3	3	2	0	1
dsPIC33CK32MP506	64	32K	8K	3	20	1	1/8	1	4	2	3	3	3	2	4	1	1	8x2	3	3	3	1	1
dsPIC33CK32MP505	48	32K	8K	3	19	1	1/8	1	4	2	3	3	3	2	4	1	1	8x2	3	3	3	0	1
dsPIC33CK32MP503	36	32K	8K	3	16	1	1/8	1	4	2	3	3	3	2	4	1	1	6x2	3	3	3	0	1
dsPIC33CK32MP502	28	32K	8K	3	12	1	1/8	1	4	2	3	3	3	2	4	1	1	4x2	3	3	2	0	1

**TABLE 2: dsPIC33CK256MP508 FAMILY WITHOUT CAN FD**

Product	Pins	Flash	Data RAM	ADC Module	ADC Channels	Timers	MCCP/SCCP	CAN FD	DMA Channels	SENT	UART	SPI	I <sup>2</sup> C	QEI	CLC	PTG	CRC	PWM Outputs	Analog Comparators	12-Bit DAC	Op Amp	PMP	REFO Clock
dsPIC33CK256MP208	80	256K	24K	3	24	1	1/8	0	4	2	3	3	3	2	4	1	1	8x2	3	3	3	1	1
dsPIC33CK256MP206	64	256K	24K	3	20	1	1/8	0	4	2	3	3	3	2	4	1	1	8x2	3	3	3	1	1
dsPIC33CK256MP205	48	256K	24K	3	19	1	1/8	0	4	2	3	3	3	2	4	1	1	8x2	3	3	3	0	1
dsPIC33CK256MP203	36	256K	24K	3	16	1	1/8	0	4	2	3	3	3	2	4	1	1	6x2	3	3	3	0	1
dsPIC33CK256MP202	28	256K	24K	3	12	1	1/8	0	4	2	3	3	3	2	4	1	1	4x2	3	3	2	0	1
dsPIC33CK128MP208	80	128K	16K	3	24	1	1/8	0	4	2	3	3	3	2	4	1	1	8x2	3	3	3	1	1
dsPIC33CK128MP206	64	128K	16K	3	20	1	1/8	0	4	2	3	3	3	2	4	1	1	8x2	3	3	3	1	1
dsPIC33CK128MP205	48	128K	16K	3	19	1	1/8	0	4	2	3	3	3	2	4	1	1	8x2	3	3	3	0	1
dsPIC33CK128MP203	36	128K	16K	3	16	1	1/8	0	4	2	3	3	3	2	4	1	1	6x2	3	3	3	0	1
dsPIC33CK128MP202	28	128K	16K	3	12	1	1/8	0	4	2	3	3	3	2	4	1	1	4x2	3	3	2	0	1
dsPIC33CK64MP208	80	64K	8K	3	24	1	1/8	0	4	2	3	3	3	2	4	1	1	8x2	3	3	3	1	1
dsPIC33CK64MP206	64	64K	8K	3	20	1	1/8	0	4	2	3	3	3	2	4	1	1	8x2	3	3	3	1	1
dsPIC33CK64MP205	48	64K	8K	3	19	1	1/8	0	4	2	3	3	3	2	4	1	1	8x2	3	3	3	0	1
dsPIC33CK64MP203	36	64K	8K	3	16	1	1/8	0	4	2	3	3	3	2	4	1	1	6x2	3	3	3	0	1
dsPIC33CK64MP202	28	64K	8K	3	12	1	1/8	0	4	2	3	3	3	2	4	1	1	4x2	3	3	2	0	1
dsPIC33CK32MP206	64	32K	8K	3	20	1	1/8	0	4	2	3	3	3	2	4	1	1	8x2	3	3	3	1	1
dsPIC33CK32MP205	48	32K	8K	3	19	1	1/8	0	4	2	3	3	3	2	4	1	1	8x2	3	3	3	0	1
dsPIC33CK32MP203	36	32K	8K	3	16	1	1/8	0	4	2	3	3	3	2	4	1	1	6x2	3	3	3	0	1
dsPIC33CK32MP202	28	32K	8K	3	12	1	1/8	0	4	2	3	3	3	2	4	1	1	4x2	3	3	2	0	1

# dsPIC33CK256MP508 FAMILY

## Pin Diagrams



**TABLE 3: 28-PIN SSOP<sup>(1)</sup>**

Pin #	Function	Pin #	Function
1	OA1IN-/ANA1/RA1	15	PGC3/ <b>RP38</b> /SCL2/RB6
2	OA1IN+/AN9/RA2	16	TDO/AN2/CMP3A/ <b>RP39</b> /SDA3/RB7
3	DACOUT1/AN3/CMP1C/RA3	17	PGD1/AN10/ <b>RP40</b> /SCL1/RB8
4	AN4/CMP3B/IBIAS3/RA4	18	PGC1/AN11/ <b>RP41</b> /SDA1/RB9
5	AVDD	19	Vss
6	AVss	20	VDD
7	VDD	21	TMS/ <b>RP42</b> /PWM3H/RB10 <sup>(2)</sup>
8	Vss	22	TCK/ <b>RP43</b> /PWM3L/RB11
9	OSCI/CLKI/AN5/ <b>RP32</b> /RB0	23	TDI/ <b>RP44</b> /PWM2H/RB12
10	OSCO/CLKO/AN6/ <b>RP33</b> /RB1 <sup>(3)</sup>	24	<b>RP45</b> /PWM2L/RB13
11	OA2OUT/AN1/AN7/ANA0/CMP1D/CMP2D/CMP3D/ <b>RP34</b> /SCL3/INT0/RB2	25	<b>RP46</b> /PWM1H/RB14
12	PGD2/OA2IN-/AN8/ <b>RP35</b> /RB3	26	<b>RP47</b> /PWM1L/RB15
13	PGC2/OA2IN+/ <b>RP36</b> /RB4	27	MCLR
14	PGD3/ <b>RP37</b> /SDA2/RB5	28	OA1OUT/AN0/CMP1A/IBIAS0/RA0

**Note 1:** RPN represents remappable peripheral functions.

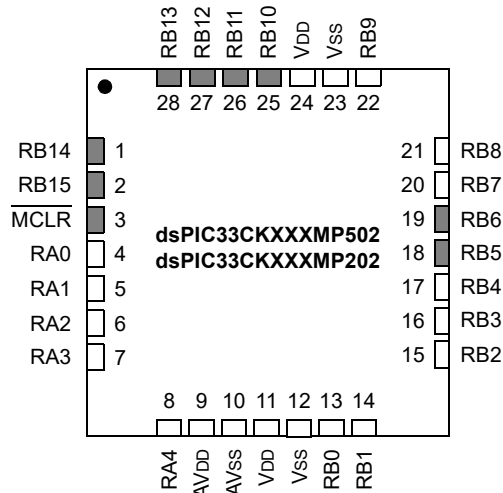
**2:** A pull-up resistor is connected to this pin when device is erased (JTAG enabled) and during programming.

**3:** This pin is toggled during programming.

# dsPIC33CK256MP508 FAMILY

## Pin Diagrams (Continued)

### 28-Pin UQFN<sup>(1,2)</sup>



**Note 1:** Shaded pins are up to 5 VDC tolerant.

**2:** The large center pad on the bottom of the package may be left floating or connected to Vss. The four-corner anchor pads are internally connected to the large bottom pad, and therefore, must be connected to the same net as the large center pad.

**TABLE 4: 28-PIN UQFN<sup>(1)</sup>**

Pin #	Function	Pin #	Function
1	RP46/PWM1H/RB14	15	OA2OUT/AN1/AN7/ANA0/CMP1D/CMP2D/CMP3D/RP34/SCL3/INT0/RB2
2	RP47/PWM1L/RB15	16	PGD2/OA2IN-/AN8/RP35/RB3
3	MCLR	17	PGC2/OA2IN+/RP36/RB4
4	OA1OUT/AN0/CMP1A/IBIAS0/RA0	18	PGD3/RP37/SDA2/RB5
5	OA1IN-/ANA1/RA1	19	PGC3/RP38/SCL2/RB6
6	OA1IN+/AN9/RA2	20	TDO/AN2/CMP3A/RP39/SDA3/RB7
7	DACOUT1/AN3/CMP1C/RA3	21	PGD1/AN10/RP40/SCL1/RB8
8	AN4/CMP3B/IBIAS3/RA4	22	PGC1/AN11/RP41/SDA1/RB9
9	AVDD	23	VSS
10	AVSS	24	VDD
11	VDD	25	TMS/RP42/PWM3H/RB10 <sup>(2)</sup>
12	VSS	26	TCK/RP43/PWM3L/RB11
13	OSCI/CLKI/AN5/RP32/RB0	27	TDI/RP44/PWM2H/RB12
14	OSCO/CLKO/AN6/RP33/RB1 <sup>(3)</sup>	28	RP45/PWM2L/RB13

**Note 1:** RPn represents remappable peripheral functions.

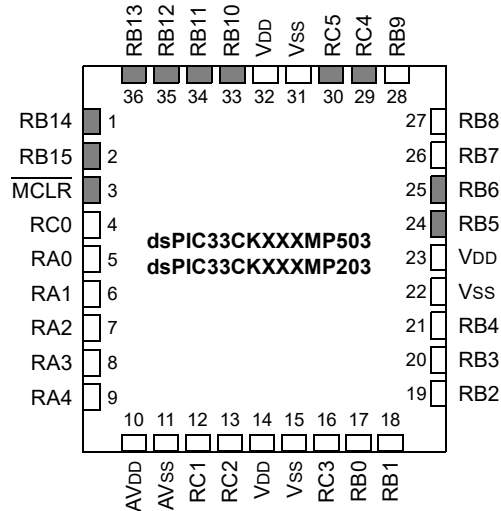
**2:** A pull-up resistor is connected to this pin when device is erased (JTAG enabled) and during programming.

**3:** This pin is toggled during programming.

# dsPIC33CK256MP508 FAMILY

## Pin Diagrams (Continued)

### 36-Pin UQFN<sup>(1,2)</sup>



**Note 1:** Shaded pins are up to 5 VDC tolerant.

**2:** The large center pad on the bottom of the package may be left floating or connected to VSS. The four-corner anchor pads are internally connected to the large bottom pad, and therefore, must be connected to the same net as the large center pad.

**TABLE 5: 36-PIN UQFN<sup>(1)</sup>**

Pin #	Function	Pin #	Function
1	RP46/PWM1H/RB14	19	OA2OUT/AN1/AN7/ANA0/CMP1D/CMP2D/CMP3D/RP34/SCL3/INT0/RB2
2	RP47/PWM1L/RB15	20	PGD2/OA2IN-/AN8/RP35/RB3
3	MCLR	21	PGC2/OA2IN+/RP36/RB4
4	AN12/ANNO/RP48/RC0	22	VSS
5	OA1OUT/AN0/CMP1A/IBIAS0/RA0	23	VDD
6	OA1IN-/ANA1/RA1	24	PGD3/RP37/PWM6L/SDA2/RB5
7	OA1IN+/AN9/RA2	25	PGC3/RP38/PWM6H/SCL2/RB6
8	DACOUT1/AN3/CMP1C/RA3	26	TDO/AN2/CMP3A/RP39/SDA3/RB7
9	OA3OUT/AN4/CMP3B/IBIAS3/RA4	27	PGD1/AN10/RP40/SCL1/RB8
10	AVDD	28	PGC1/AN11/RP41/SDA1/RB9
11	AVSS	29	RP52/PWM5H/ASDA2/RC4
12	OA3IN-/AN13/CMP1B/ISRC0/RP49/RC1	30	RP53/PWM5L/ASCL2/RC5
13	OA3IN+/AN14/CMP2B/ISRC1/RP50/RC2	31	VSS
14	VDD	32	VDD
15	VSS	33	TMS/RP42/PWM3H/RB10 <sup>(2)</sup>
16	AN15/CMP2A/IBIAS2/RP51/RC3	34	TCK/RP43/PWM3L/RB11
17	OSCI/CLKI/AN5/RP32/RB0	35	TDI/RP44/PWM2H/RB12
18	OSCO/CLKO/AN6/RP33/RB1 <sup>(3)</sup>	36	RP45/PWM2L/RB13

**Note 1:** RPN represents remappable peripheral functions.

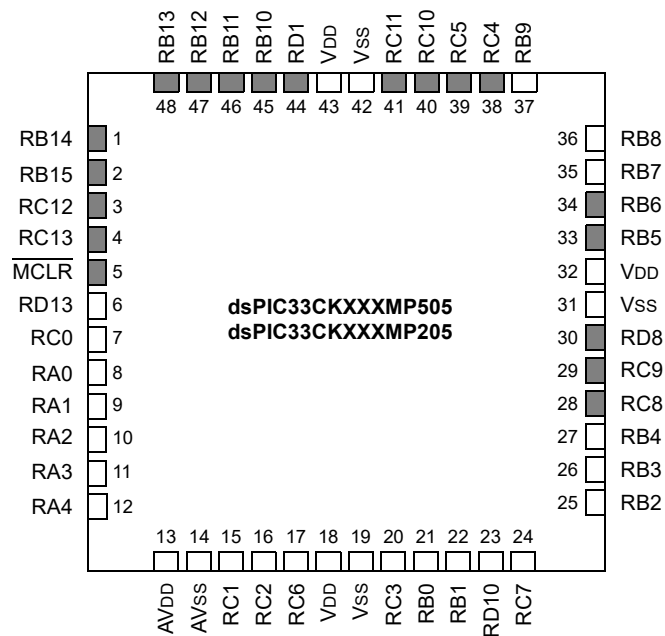
**2:** A pull-up resistor is connected to this pin when device is erased (JTAG enabled) and during programming.

**3:** This pin is toggled during programming.

# dsPIC33CK256MP508 FAMILY

## Pin Diagrams (Continued)

48-Pin TQFP, UQFN<sup>(1,2)</sup>



**Note 1:** Shaded pins are up to 5 VDC tolerant.

**Note 2:** The large center pad on the bottom of the package may be left floating or connected to VSS. The four-corner anchor pads are internally connected to the large bottom pad, and therefore, must be connected to the same net as the large center pad.



# dsPIC33CK256MP508 FAMILY

**TABLE 6: 48-PIN TQFP, UQFN<sup>(1)</sup>**

Pin #	Function	Pin #	Function
1	RP46/PWM1H/RB14	25	OA2OUT/AN1/AN7/ANA0/CMP1D/CMP2D/CMP3D/RP34/SCL3/INT0/RB2
2	RP47/PWM1L/RB15	26	PGD2/OA2IN-/AN8/RP35/RB3
3	RP60/PWM8H/RC12	27	PGC2/OA2IN+/RP36/RB4
4	RP61/PWM8L/RC13	28	RP56/ASDA1/SCK2/RC8
5	MCLR	29	RP57/ASCL1/SDI2/RC9
6	ANN2/RP77/RD13	30	RP72/SDO2/PCI19/RD8
7	AN12/ANN0/RP48/RC0	31	Vss
8	OA1OUT/AN0/CMP1A/IBIAS0/RA0	32	VDD
9	OA1IN-/ANA1/RA1	33	PGD3/RP37/PWM6L/SDA2/RB5
10	OA1IN+/AN9/RA2	34	PGC3/RP38/PWM6H/SCL2/RB6
11	DACOUT1/AN3/CMP1C/RA3	35	TDO/AN2/CMP3A/RP39/SDA3/RB7
12	OA3OUT/AN4/CMP3B/IBIAS3/RA4	36	PGD1/AN10/RP40/SCL1/RB8
13	AVDD	37	PGC1/AN11/RP41/SDA1/RB9
14	AVss	38	RP52/PWM5H/ASDA2/RC4
15	OA3IN-/AN13/CMP1B/ISRC0/RP49/RC1	39	RP53/PWM5L/ASCL2/RC5
16	OA3IN+/AN14/CMP2B/ISRC1/RP50/RC2	40	RP58/PWM7H/RC10
17	AN17/ANN1/IBIAS1/RP54/RC6	41	RP59/PWM7L/RC11
18	VDD	42	Vss
19	Vss	43	VDD
20	AN15/CMP2A/IBIAS2/RP51/RC3	44	RP65/PWM4H/RD1
21	OSCI/CLKI/AN5/RP32/RB0	45	TMS/RP42/PWM3H/RB10 <sup>(2)</sup>
22	OSCO/CLKO/AN6/RP33/RB1 <sup>(3)</sup>	46	TCK/RP43/PWM3L/RB11
23	AN18/CMP3C/ISRC3/RP74/RD10	47	TDI/RP44/PWM2H/RB12
24	AN16/ISRC2/RP55/RC7	48	RP45/PWM2L/RB13

**Note 1:** RPN represents remappable peripheral functions.

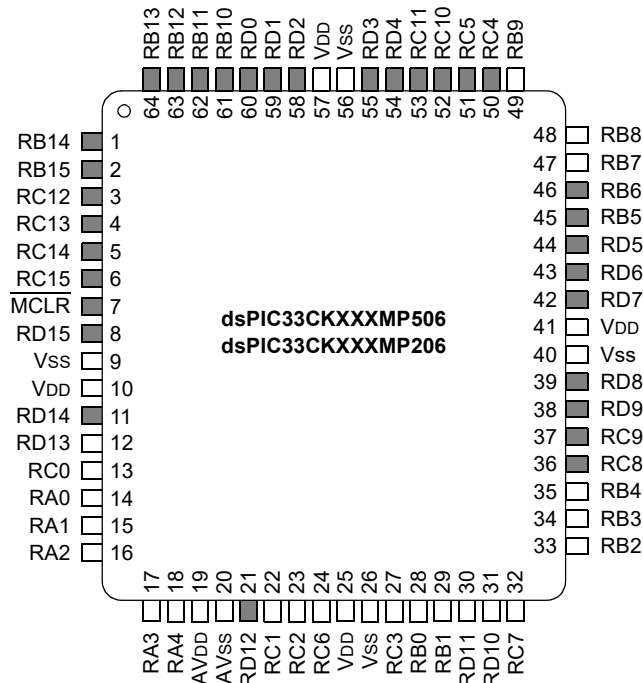
**2:** A pull-up resistor is connected to this pin when device is erased (JTAG enabled) and during programming.

**3:** This pin is toggled during programming.

# dsPIC33CK256MP508 FAMILY

## Pin Diagrams (Continued)

64-Pin TQFP, QFN



**Note:** Shaded pins are up to 5 VDC tolerant.

# dsPIC33CK256MP508 FAMILY

**TABLE 7: 64-PIN TQFP, QFN<sup>(1)</sup>**

Pin #	Function	Pin #	Function
1	RP46/PWM1H/PMD5/RB14	33	OA2OUT/AN1/AN7/ANA0/CMP1D/CMP2D/CMP3D/RP34/SCL3/INT0/RB2
2	RP47/PWM1L/PMD6/RB15	34	PGD2/OA2IN-/AN8/RP35/RB3
3	RP60/PWM8H/PMD7/RC12	35	PGC2/OA2IN+/RP36/RB4
4	RP61/PWM8L/PMA5/RC13	36	RP56/ASDA1/SCK2/RC8
5	RP62/PWM6H/PMA4/RC14	37	RP57/ASCL1/SDI2/RC9
6	RP63/PWM6L/PMA3/RC15	38	RP73/PCI20/RD9
7	MCLR	39	RP72/SDO2/PCI19/RD8
8	RP79/PCI22/PMA2/RD15	40	Vss
9	Vss	41	VDD
10	VDD	42	RP71/PMD15/RD7
11	RP78/PCI21/RD14	43	RP70/PMD14/RD6
12	ANN2/RP77/RD13	44	RP69/PMA15/PMCS2/RD5
13	AN12/ANN0/RP48/RC0	45	PGD3/RP37/SDA2/PMA14/PMCS1/PSCS/RB5
14	OA1OUT/AN0/CMP1A/IBIAS0/RA0	46	PGC3/RP38/SCL2/RB6
15	OA1IN-/ANA1/RA1	47	TDO/AN2/CMP3A/RP39/SDA3/RB7
16	OA1IN+/AN9/PMA6/RA2	48	PGD1/AN10/RP40/SCL1/RB8
17	DACOUT1/AN3/CMP1C/RA3	49	PGC1/AN11/RP41/SDA1/RB9
18	OA3OUT/AN4/CMP3B/IBIAS3/RA4	50	RP52/PWM5H/ASDA2/RC4
19	AVDD	51	RP53/PWM5L/ASCL2/PMWR/PMENB/PSWR/RC5
20	AVss	52	RP58/PWM7H/PMRD/PMWR/PSRD/RC10
21	RP76/RD12	53	RP59/PWM7L/RC11
22	OA3IN-/AN13/CMP1B/ISRC0/RP49/PMA7/RC1	54	RP68/ASDA3/RD4
23	OA3IN+/AN14/CMP2B/ISRC1/RP50/PMD13/PMA13/RC2	55	RP67/ASCL3/RD3
24	AN17/ANN1/IBIAS1/RP54/PMD12/PMA12/RC6	56	Vss
25	VDD	57	VDD
26	Vss	58	RP66/RD2
27	AN15/CMP2A/IBIAS2/RP51/PMD11/PMA11/RC3	59	RP65/PWM4H/RD1
28	OSCI/CLKI/AN5/RP32/PMD10/PMA10/RB0	60	RP64/PWM4L/PMD0/RD0
29	OSCO/CLKO/AN6/RP33/PMA1/PMALH/PSA1/RB1 <sup>(3)</sup>	61	TMS/RP42/PWM3H/PMD1/RB10 <sup>(2)</sup>
30	AN19/CMP2C/RP75/PMA0/PMALL/PSA0/RD11	62	TCK/RP43/PWM3L/PMD2/RB11
31	AN18/CMP3C/ISRC3/RP74/PMD9/PMA9/RD10	63	TDI/RP44/PWM2H/PMD3/RB12
32	AN16/ISRC2/RP55/PMD8/PMA8/RC7	64	RP45/PWM2L/PMD4/RB13

**Note 1:** R<sub>Pn</sub> represents remappable peripheral functions.

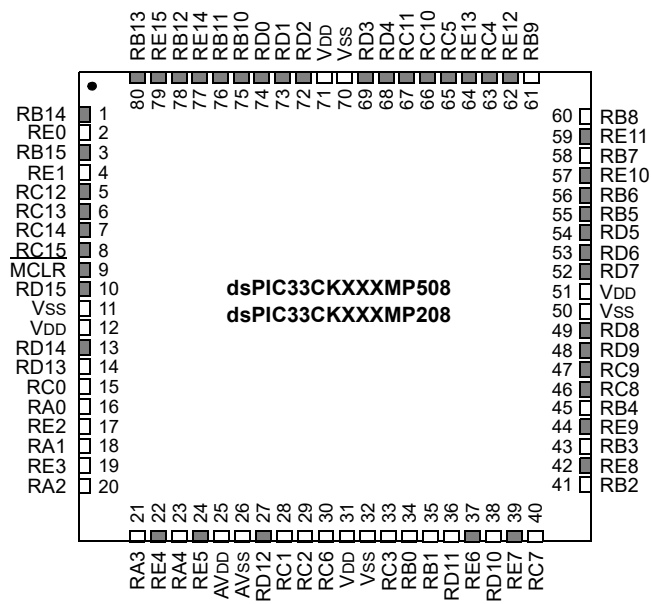
**2:** A pull-up resistor is connected to this pin when device is erased (JTAG enabled) and during programming.

**3:** This pin is toggled during programming.

# dsPIC33CK256MP508 FAMILY

## Pin Diagrams (Continued)

80-Pin TQFP



**Note:** Shaded pins are up to 5 VDC tolerant.

# dsPIC33CK256MP508 FAMILY

**TABLE 8: 80-PIN TQFP<sup>(1)</sup>**

Pin #	Function	Pin #	Function
1	<b>RP46</b> /PWM1H/PMD5/RB14	41	OA2OUT/AN1/AN7/ANA0/CMP1D/CMP2D/CMP3D/ <b>RP34</b> /SCL3/INT0/RB2
2	AN20/RE0	42	RE8
3	<b>RP47</b> /PWM1L/PMD6/RB15	43	PGD2/OA2IN-/AN8/ <b>RP35</b> /RB3
4	AN21/RE1	44	RE9
5	<b>RP60</b> /PWM8H/PMD7/RC12	45	PGC2/OA2IN+/ <b>RP36</b> /RB4
6	<b>RP61</b> /PWM8L/PMA5/RC13	46	<b>RP56</b> /ASDA1/SCK2/RC8
7	<b>RP62</b> /PWM6H/PMA4/RC14	47	<b>RP57</b> /ASCL1/SDI2/RC9
8	<b>RP63</b> /PWM6L/PMA3/RC15	48	<b>RP73</b> /PCI20/RD9
9	MCLR	49	<b>RP72</b> /SDO2/PCI19/RD8
10	<b>RP79</b> /PCI22/PMA2/RD15	50	Vss
11	Vss	51	VDD
12	VDD	52	<b>RP71</b> /PMD15/RD7
13	<b>RP78</b> /PCI21/RD14	53	<b>RP70</b> /PMD14/RD6
14	ANN2/ <b>RP77</b> /RD13	54	<b>RP69</b> /PMA15/PMCS2/RD5
15	AN12/ANN0/ <b>RP48</b> /RC0	55	PGD3/ <b>RP37</b> /SDA2/PMA14/PMCS1/PSCS/RB5
16	OA1OUT/AN0/CMP1A/IBIAS0/RA0	56	PGC3/ <b>RP38</b> /SCL2/RB6
17	AN22/RE2	57	RE10
18	OA1IN-/ANA1/RA1	58	TDO/AN2/CMP3A/ <b>RP39</b> /SDA3/RB7
19	AN23/RE3	59	RE11
20	OA1IN+/AN9/PMA6/RA2	60	PGD1/AN10/ <b>RP40</b> /SCL1/RB8
21	DACOUT1/AN3/CMP1C/RA3	61	PGC1/AN11/ <b>RP41</b> /SDA1/RB9
22	RE4	62	RE12
23	OA3OUT/AN4/CMP3B/IBIAS3/RA4	63	<b>RP52</b> /PWM5H/ASDA2/RC4
24	RE5	64	RE13
25	AVDD	65	<b>RP53</b> /PWM5L/ASCL2/PMWR/PMENB/PSWR/RC5
26	AVss	66	<b>RP58</b> /PWM7H/PMRD/PMWR/PSRD/RC10
27	<b>RP76</b> /RD12	67	<b>RP59</b> /PWM7L/RC11
28	OA3IN-/AN13/CMP1B/ISRC0/ <b>RP49</b> /PMA7/RC1	68	<b>RP68</b> /ASDA3/RD4
29	OA3IN+/AN14/CMP2B/ISRC1/ <b>RP50</b> /PMD13/PMA13/RC2	69	<b>RP67</b> /ASCL3/RD3
30	AN17/ANN1/IBIAS1/ <b>RP54</b> /PMD12/PMA12/RC6	70	Vss
31	VDD	71	VDD
32	Vss	72	<b>RP66</b> /RD2
33	AN15/CMP2A/IBIAS2/ <b>RP51</b> /PMD11/PMA11/RC3	73	<b>RP65</b> /PWM4H/RD1
34	OSCI/CLKI/AN5/ <b>RP32</b> /PMD10/PMA10/RB0	74	<b>RP64</b> /PWM4L/PMD0/RD0
35	OSCO/CLKO/AN6/ <b>RP33</b> /PMA1/PMALH/PSA1/RB1 <sup>(3)</sup>	75	TMS/ <b>RP42</b> /PWM3H/PMD1/RB10 <sup>(2)</sup>
36	AN19/CMP2C/ <b>RP75</b> /PMA0/PMALL/PSA0/RD11	76	TCK/ <b>RP43</b> /PWM3L/PMD2/RB11
37	RE6	77	RE14
38	AN18/CMP3C/ISRC3/ <b>RP74</b> /PMD9/PMA9/RD10	78	TDI/ <b>RP44</b> /PWM2H/PMD3/RB12
39	RE7	79	RE15
40	AN16/ISRC2/ <b>RP55</b> /PMD8/PMA8/RC7	80	<b>RP45</b> /PWM2L/PMD4/RB13

**Note 1:** R<sub>Pn</sub> represents remappable peripheral functions.

**2:** A pull-up resistor is connected to this pin when device is erased (JTAG enabled) and during programming.

**3:** This pin is toggled during programming.

# dsPIC33CK256MP508 FAMILY

---

---

## Table of Contents

1.0	Device Overview .....	19
2.0	Guidelines for Getting Started with High-Performance Digital Signal Controllers .....	25
3.0	CPU .....	31
4.0	Memory Organization .....	43
5.0	Flash Program Memory .....	81
6.0	Resets .....	97
7.0	Interrupt Controller .....	101
8.0	I/O Ports .....	121
9.0	Oscillator with High-Frequency PLL .....	185
10.0	Direct Memory Access (DMA) Controller .....	211
11.0	Controller Area Network (CAN FD) Module .....	221
12.0	High-Resolution PWM with Fine Edge Placement .....	265
13.0	High-Speed, 12-Bit Analog-to-Digital Converter (ADC).....	301
14.0	High-Speed Analog Comparator with Slope Compensation DAC .....	331
15.0	Quadrature Encoder Interface (QEI) .....	343
16.0	Universal Asynchronous Receiver Transmitter (UART) .....	363
17.0	Serial Peripheral Interface (SPI).....	385
18.0	Inter-Integrated Circuit (I <sup>2</sup> C).....	403
19.0	Parallel Master Port (PMP).....	413
20.0	Single-Edge Nibble Transmission (SENT) .....	427
21.0	Timer1 .....	437
22.0	Capture/Compare/PWM/Timer Modules (SCCP/MCCP) .....	441
23.0	Configurable Logic Cell (CLC).....	455
24.0	Peripheral Trigger Generator (PTG).....	467
25.0	32-Bit Programmable Cyclic Redundancy Check (CRC) Generator .....	483
26.0	Current Bias Generator (CBG).....	487
27.0	Operational Amplifier .....	491
28.0	Deadman Timer (DMT) .....	495
29.0	Power-Saving Features .....	503
30.0	Special Features .....	515
31.0	Instruction Set Summary .....	541
32.0	Development Support .....	551
33.0	Electrical Characteristics .....	553
34.0	High-Temperature Electrical Characteristics .....	593
35.0	Packaging Information.....	603
	Appendix A: Revision History.....	629
	Index .....	633
	The Microchip Website .....	641
	Customer Change Notification Service .....	641
	Customer Support .....	641
	Product Identification System.....	643

## TO OUR VALUED CUSTOMERS

It is our intention to provide our valued customers with the best documentation possible to ensure successful use of your Microchip products. To this end, we will continue to improve our publications to better suit your needs. Our publications will be refined and enhanced as new volumes and updates are introduced.

If you have any questions or comments regarding this publication, please contact the Marketing Communications Department via E-mail at [docerrors@microchip.com](mailto:docerrors@microchip.com). We welcome your feedback.

### Most Current Data Sheet

To obtain the most up-to-date version of this data sheet, please register at our Worldwide Website at:

<http://www.microchip.com>

You can determine the version of a data sheet by examining its literature number found on the bottom outside corner of any page. The last character of the literature number is the version number, (e.g., DS30000000A is version A of document DS30000000).

### Errata

An errata sheet, describing minor operational differences from the data sheet and recommended workarounds, may exist for current devices. As device/documentation issues become known to us, we will publish an errata sheet. The errata will specify the revision of silicon and revision of document to which it applies.

To determine if an errata sheet exists for a particular device, please check with one of the following:

- Microchip's Worldwide Website; <http://www.microchip.com>
- Your local Microchip sales office (see last page)

When contacting a sales office, please specify which device, revision of silicon and data sheet (include literature number) you are using.

### Customer Notification System

Register on our website at [www.microchip.com](http://www.microchip.com) to receive the most current information on all of our products.

# dsPIC33CK256MP508 FAMILY

---

## Referenced Sources

This device data sheet is based on the following individual chapters of the “*dsPIC33/PIC24 Family Reference Manual*”. These documents should be considered as the general reference for the operation of a particular module or device feature.

**Note 1:** To access the documents listed below, browse to the documentation section of the dsPIC33CK256MP508 product page of the Microchip website ([www.microchip.com](http://www.microchip.com)) or select a family reference manual section from the following list.

In addition to parameters, features and other documentation, the resulting page provides links to the related family reference manual sections.

- “Introduction” ([www.microchip.com/DS70573](http://www.microchip.com/DS70573))
- “Enhanced CPU” ([www.microchip.com/DS70005158](http://www.microchip.com/DS70005158))
- “dsPIC33/PIC24 Program Memory” ([www.microchip.com/DS70000613](http://www.microchip.com/DS70000613))
- “Data Memory” ([www.microchip.com/DS70595](http://www.microchip.com/DS70595))
- “Dual Partition Flash Program Memory” ([www.microchip.com/DS70005156](http://www.microchip.com/DS70005156))
- “Flash Programming” ([www.microchip.com/DS70000609](http://www.microchip.com/DS70000609))
- “Reset” ([www.microchip.com/DS70602](http://www.microchip.com/DS70602))
- “Interrupts” ([www.microchip.com/DS70000600](http://www.microchip.com/DS70000600))
- “I/O Ports with Edge Detect” ([www.microchip.com/DS70005322](http://www.microchip.com/DS70005322))
- “Oscillator Module with High-Speed PLL” ([www.microchip.com/DS70005255](http://www.microchip.com/DS70005255))
- “Direct Memory Access Controller (DMA)” ([www.microchip.com/DS30009742](http://www.microchip.com/DS30009742))
- “CAN Flexible Data-Rate (FD) Protocol Module” ([www.microchip.com/DS70005340](http://www.microchip.com/DS70005340))
- “High-Resolution PWM with Fine Edge Placement” ([www.microchip.com/DS70005320](http://www.microchip.com/DS70005320))
- “12-Bit High-Speed, Multiple SARs A/D Converter (ADC)” ([www.microchip.com/DS70005213](http://www.microchip.com/DS70005213))
- “High-Speed Analog Comparator Module with Slope Compensation DAC” ([www.microchip.com/DS70005280](http://www.microchip.com/DS70005280))
- “Quadrature Encoder Interface (QEI)” ([www.microchip.com/DS70000601](http://www.microchip.com/DS70000601))
- “Multiprotocol Universal Asynchronous Receiver Transmitter (UART) Module” ([www.microchip.com/DS70005288](http://www.microchip.com/DS70005288))
- “Serial Peripheral Interface (SPI) with Audio Codec Support” ([www.microchip.com/DS70005136](http://www.microchip.com/DS70005136))
- “Inter-Integrated Circuit (I<sup>2</sup>C)” ([www.microchip.com/DS70000195](http://www.microchip.com/DS70000195))
- “Parallel Master Port (PMP)” ([www.microchip.com/DS70005344](http://www.microchip.com/DS70005344))
- “Single-Edge Nibble Transmission (SENT) Module” ([www.microchip.com/DS70005145](http://www.microchip.com/DS70005145))
- “Timer1 Module” ([www.microchip.com/DS70005279](http://www.microchip.com/DS70005279))
- “Capture/Compare/PWM/Timer (MCCP and SCCP)” ([www.microchip.com/DS30003035](http://www.microchip.com/DS30003035))
- “Configurable Logic Cell (CLC)” ([www.microchip.com/DS70005298](http://www.microchip.com/DS70005298))
- “Peripheral Trigger Generator (PTG)” ([www.microchip.com/DS70000669](http://www.microchip.com/DS70000669))
- “32-Bit Programmable Cyclic Redundancy Check (CRC)” ([www.microchip.com/DS30009729](http://www.microchip.com/DS30009729))
- “Current Bias Generator (CBG)” ([www.microchip.com/DS70005253](http://www.microchip.com/DS70005253))
- “Deadman Timer” ([www.microchip.com/DS70005155](http://www.microchip.com/DS70005155))
- “Watchdog Timer and Power-Saving Modes” ([www.microchip.com/DS70615](http://www.microchip.com/DS70615))
- “CodeGuard™ Intermediate Security” ([www.microchip.com/DS70005182](http://www.microchip.com/DS70005182))
- “Dual Watchdog Timer” ([www.microchip.com/DS70005250](http://www.microchip.com/DS70005250))
- “Programming and Diagnostics” ([www.microchip.com/DS70608](http://www.microchip.com/DS70608))



## Terminology Cross Reference

Table 9 provides updated terminology for depreciated naming conventions. Register and bit names remain unchanged, however, descriptions and usage guidance may have been updated.

**TABLE 9: TERMINOLOGY CROSS REFERENCES**

Use Case	Deprecated Term	New Term
CPU	Master	Initiator
DMA	Master	Initiator
I <sup>2</sup> C	Master	Host
	Slave	Client
SPI	Master	Host
	Slave	Client
PMP	Master	Host
	Slave	Client
UART, LIN mode	Master	Commander
	Slave	Responder
PWM	Master	Host
	Slave	Client

# dsPIC33CK256MP508 FAMILY

---

NOTES:

# dsPIC33CK256MP508 FAMILY

## 1.0 DEVICE OVERVIEW

**Note 1:** This data sheet summarizes the features of the dsPIC33CK256MP508 family of devices. It is not intended to be a comprehensive resource. To complement the information in this data sheet, refer to the related section of the “dsPIC33/PIC24 Family Reference Manual”, which is available from the Microchip website ([www.microchip.com](http://www.microchip.com)).

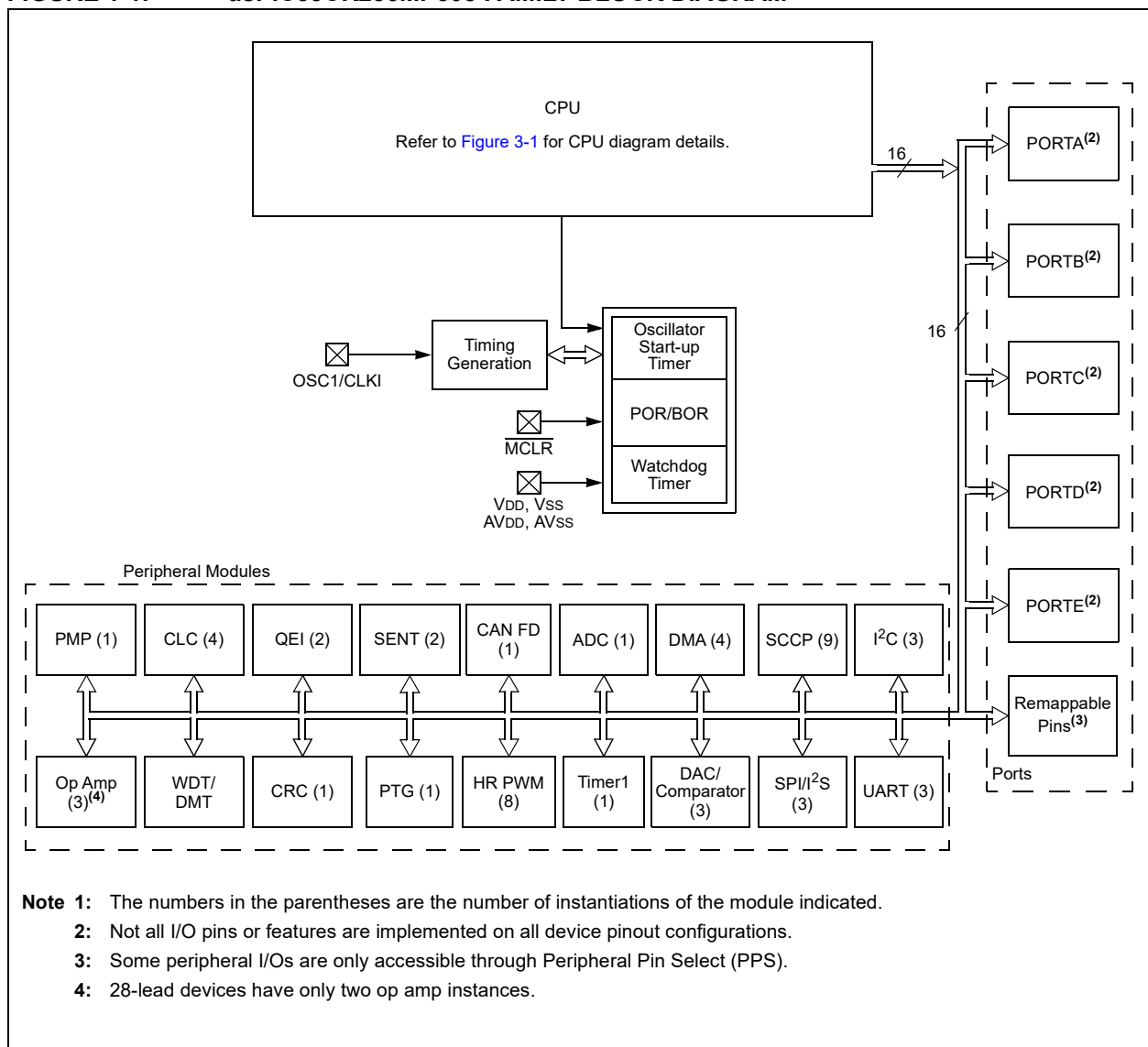
**2:** Some registers and associated bits described in this section may not be available on all devices. Refer to **Section 4.0 “Memory Organization”** in this data sheet for device-specific register and bit information.

This document contains device-specific information for the dsPIC33CK256MP508 Digital Signal Controller (DSC) devices.

dsPIC33CK256MP508 devices contain extensive Digital Signal Processor (DSP) functionality with a high-performance, 16-bit MCU architecture.

Figure 1-1 shows a general block diagram of the core and peripheral modules of the dsPIC33CK256MP508 family. Table 1-1 lists the functions of the various pins shown in the pinout diagrams.

**FIGURE 1-1: dsPIC33CK256MP508 FAMILY BLOCK DIAGRAM<sup>(1)</sup>**



# dsPIC33CK256MP508 FAMILY

**TABLE 1-1: PINOUT I/O DESCRIPTIONS**

Pin Name <sup>(1)</sup>	Pin Type	Buffer Type	PPS	Description
AN0-AN23	I	Analog	No	Analog input channels
ANA0-ANA1	I	Analog	No	Analog alternate inputs
ANN0-ANN2	I	Analog	No	Analog negative inputs
ADTRG31	I	ST	Yes	ADC Trigger Input 31
CLKI	I	ST/ CMOS	No	External Clock (EC) source input. Always associated with OSCI pin function.
CLKO	O	—	No	Oscillator crystal output. Connects to crystal or resonator in Crystal Oscillator mode. Optionally functions as CLKO in RC and EC modes. Always associated with OSCO pin function.
OSCI	I	ST/ CMOS	No	Oscillator crystal input. ST buffer when configured in RC mode; CMOS otherwise.
OSCO	I/O	—	No	Oscillator crystal output. Connects to crystal or resonator in Crystal Oscillator mode. Optionally functions as CLKO in RC and EC modes.
REFCLKO	O	—	Yes	Reference clock output
REFOI	I	ST	Yes	Reference clock input
INT0	I	ST	No	External Interrupt 0
INT1	I	ST	Yes	External Interrupt 1
INT2	I	ST	Yes	External Interrupt 2
INT3	I	ST	Yes	External Interrupt 3
IOCA[4:0]	I	ST	No	Interrupt-on-Change input for PORTA
IOCB[15:0]	I	ST	No	Interrupt-on-Change input for PORTB
IOCC[15:0]	I	ST	No	Interrupt-on-Change input for PORTC
IOCD[15:0]	I	ST	No	Interrupt-on-Change input for PORTD
IOCE[15:0]	I	ST	No	Interrupt-on-Change input for PORTE
RP32-RP71	I/O	ST	Yes	Remappable I/O ports
RA0-RA4	I/O	ST	No	PORTA is a bidirectional I/O port
RB0-RB15	I/O	ST	No	PORTB is a bidirectional I/O port
RC0-RC15	I/O	ST	No	PORTC is a bidirectional I/O port
RD0-RD15	I/O	ST	No	PORTD is a bidirectional I/O port
RE0-RE15	I/O	ST	No	PORTE is a bidirectional I/O port
T1CK	I	ST	Yes	Timer1 external clock input
CAN1RX	I	ST	Yes	CAN1 receive input
CAN1TX	O	—	Yes	CAN1 transmit output
U1CTS	I	ST	Yes	UART1 Clear-to-Send
U1RTS	O	—	Yes	UART1 Request-to-Send
U1RX	I	ST	Yes	UART1 receive
U1TX	O	—	Yes	UART1 transmit
U1DSR	I	ST	Yes	UART1 Data-Set-Ready
U1DTR	O	—	Yes	UART1 Data-Terminal-Ready

**Legend:** CMOS = CMOS compatible input or output      Analog = Analog input      P = Power  
 ST = Schmitt Trigger input with CMOS levels      O = Output      I = Input  
 PPS = Peripheral Pin Select      TTL = TTL input buffer      DIG = Digital

- Note 1:** Not all pins are available in all package variants. See the **“Pin Diagrams”** section for pin availability.
- 2:** PWM4L and PWM4H pins are available on PPS as well as dedicated.
- 3:** SPI2 supports dedicated pins as well as PPS on 48, 64 and 80-pin devices.
- 4:** Only 48, 64 and 80-pin devices have all eight PWM output pairs on dedicated pins. Refer to the **“Pin Diagrams”** for PWM pin availability on other packages.

# dsPIC33CK256MP508 FAMILY

**TABLE 1-1: PINOUT I/O DESCRIPTIONS (CONTINUED)**

Pin Name <sup>(1)</sup>	Pin Type	Buffer Type	PPS	Description
U2CTS	I	ST	Yes	UART2 Clear-to-Send
U2RTS	O	—	Yes	UART2 Request-to-Send
U2RX	I	ST	Yes	UART2 receive
U2TX	O	—	Yes	UART2 transmit
U2DSR	I	ST	Yes	UART2 Data-Set-Ready
U2DTR	O	—	Yes	UART2 Data-Terminal-Ready
U3CTS	I	ST	Yes	UART3 Clear-to-Send
U3RTS	O	—	Yes	UART3 Request-to-Send
U3RX	I	ST	Yes	UART3 receive
U3TX	O	—	Yes	UART3 transmit
U3DSR	I	ST	Yes	UART3 Data-Set-Ready
U3DTR	O	—	Yes	UART3 Data-Terminal-Ready
SCK1	I/O	ST	Yes	Synchronous serial clock input/output for SPI1
SDI1	I	ST	Yes	SPI1 data in
SDO1	O	—	Yes	SPI1 data out
SS1	I/O	ST	Yes	SPI1 client synchronization or frame pulse I/O
SCK2	I/O	ST	Yes <sup>(3)</sup>	Synchronous serial clock input/output for SPI2
SDI2	I	ST	Yes <sup>(3)</sup>	SPI2 data in
SDO2	O	—	Yes <sup>(3)</sup>	SPI2 data out
SS2	I/O	ST	Yes <sup>(3)</sup>	SPI2 client synchronization or frame pulse I/O
SCK3	I/O	ST	Yes	Synchronous serial clock input/output for SPI3
SDI3	I	ST	Yes	SPI3 data in
SDO3	O	—	Yes	SPI3 data out
SS3	I/O	ST	Yes	SPI3 client synchronization or frame pulse I/O
SCL1	I/O	ST	No	Synchronous serial clock input/output for I2C1
SDA1	I/O	ST	No	Synchronous serial data input/output for I2C1
ASCL1	I/O	ST	No	Alternate synchronous serial clock input/output for I2C1
ASDA1	I/O	ST	No	Alternate synchronous serial data input/output for I2C1
SCL2	I/O	ST	No	Synchronous serial clock input/output for I2C2
SDA2	I/O	ST	No	Synchronous serial data input/output for I2C2
ASCL2	I/O	ST	No	Alternate synchronous serial clock input/output for I2C2
ASDA2	I/O	ST	No	Alternate synchronous serial data input/output for I2C2
SCL3	I/O	ST	No	Synchronous serial clock input/output for I2C3
SDA3	I/O	ST	No	Synchronous serial data input/output for I2C3
ASCL3	I/O	ST	No	Alternate synchronous serial clock input/output for I2C3
ASDA3	I/O	ST	No	Alternate synchronous serial data input/output for I2C3
QEIA1-QEIA2	I	ST	Yes	QEI Inputs A1 and A2
QEIB1-QEIB2	I	ST	Yes	QEI Inputs B1 and B2
QEINDX1-QEINDX2	I	ST	Yes	QEI Index Inputs 1 and 2
QEIHOM1-QEIHOM2	I	ST	Yes	QEI Home Inputs 1 and 2
QEICMP1-QEICMP2	O	—	Yes	QEI Comparator Outputs 1 and 2
SENT1-SENT2	I	ST	Yes	SENT1 and SENT2 inputs
SENT1OUT-SENT2OUT	O	—	Yes	SENT1 and SENT2 outputs

**Legend:** CMOS = CMOS compatible input or output      Analog = Analog input      P = Power  
 ST = Schmitt Trigger input with CMOS levels      O = Output      I = Input  
 PPS = Peripheral Pin Select      TTL = TTL input buffer      DIG = Digital

- Note 1:** Not all pins are available in all package variants. See the “Pin Diagrams” section for pin availability.  
**2:** PWM4L and PWM4H pins are available on PPS as well as dedicated.  
**3:** SPI2 supports dedicated pins as well as PPS on 48, 64 and 80-pin devices.  
**4:** Only 48, 64 and 80-pin devices have all eight PWM output pairs on dedicated pins. Refer to the “Pin Diagrams” for PWM pin availability on other packages.

# dsPIC33CK256MP508 FAMILY

**TABLE 1-1: PINOUT I/O DESCRIPTIONS (CONTINUED)**

Pin Name <sup>(1)</sup>	Pin Type	Buffer Type	PPS	Description
TMS	I	ST	No	JTAG Test mode select pin
TCK	I	ST	No	JTAG test clock input pin
TDI	I	ST	No	JTAG test data input pin
TDO	O	—	No	JTAG test data output pin
PCI8-PCI18	I	ST	Yes	PWM PCI Inputs 8 through 18
PCI19-PCI22	I	ST	No	PWM PCI Inputs 19 through 22
PWM1L-PWM8L <sup>(2)</sup>	O	—	No <sup>(4)</sup>	PWM Low Outputs 1 through 8
PWM1H-PWM8H <sup>(2)</sup>	O	—	No <sup>(4)</sup>	PWM High Outputs 1 through 8
PWMEA-PWMED	O	—	Yes	PWM Event Outputs A through D
CMP1A-CMP3A	I	Analog	No	Comparator Channels 1A through 3A inputs
CMP1B-CMP3B	I	Analog	No	Comparator Channels 1B through 3B inputs
CMP1C-CMP3C	I	Analog	No	Comparator Channels 1C through 3C inputs
CMP1D-CMP3D	I	Analog	No	Comparator Channels 1D through 3D inputs
DACOUT1	O	—	No	DAC output voltage
TCKI1-TCKI9	I	ST	Yes	SCCP/MCCP Timer Inputs 1 through 9
ICM1-ICM9	I	ST	Yes	SCCP/MCCP Capture Inputs 1 through 9
OCFA-OCFD	I	—	Yes	SCCP/MCCP Fault Inputs A through D
OCM1-OCM9	O	—	Yes	SCCP/MCCP Compare Outputs 1 through 9
IBIAS0-IBIAS3	O	Analog	No	50 $\mu$ A Constant-Current Outputs 0 through 3
ISRC0-ISRC3	O	Analog	No	10 $\mu$ A Constant-Current Outputs 0 through 3
OA1IN+	I	—	No	Op Amp 1+ Input
OA1IN-	I	—	No	Op Amp 1- Input
OA1OUT	O	—	No	Op Amp 1 Output
OA2IN+	I	—	No	Op Amp 2+ Input
OA2IN-	I	—	No	Op Amp 2- Input
OA2OUT	O	—	No	Op Amp 2 Output
OA3IN+	I	—	No	Op Amp 3+ Input
OA3IN-	I	—	No	Op Amp 3- Input
OA3OUT	O	—	No	Op Amp 3 Output
PMA0/PMALL	O	ST/TTL	No	PMP Address 0 or address latch low
PMA1/PMALH	O	ST/TTL	No	PMP Address 1 or address latch high
PMA14/PMCS1	O	ST/TTL	No	PMP Address 14 or Chip Select 1
PMA15/PMCS2	O	ST/TTL	No	PMP Address 15 or Chip Select 2
PMA2-PMA13	O	ST/TTL	No	PMP Address Lines 2-13
PMD0-PMD15	I/O	ST/TTL	No	PMP Data Lines 0-15
PMRD/PMWR	O	ST/TTL	No	PMP read or read/write signal
PMWR/PMENB	O	ST/TTL	No	PMP write or data enable signal
PSA0	I	ST/TTL	No	PMP Client Address 0
PSA1	I	ST/TTL	No	PMP Client Address 1
PSCS	I	ST/TTL	No	PMP client chip select
PSRD	I	ST/TTL	No	PMP client read
PSWR	I	ST/TTL	No	PMP client write
CLCINA-CLCIND	I	ST	Yes	CLC Inputs A through D
CLC1OUT-CLC4OUT	O	—	Yes	CLC Outputs 1 through 4

**Legend:** CMOS = CMOS compatible input or output      Analog = Analog input      P = Power  
 ST = Schmitt Trigger input with CMOS levels      O = Output      I = Input  
 PPS = Peripheral Pin Select      TTL = TTL input buffer      DIG = Digital

- Note 1:** Not all pins are available in all package variants. See the “**Pin Diagrams**” section for pin availability.  
**2:** PWM4L and PWM4H pins are available on PPS as well as dedicated.  
**3:** SPI2 supports dedicated pins as well as PPS on 48, 64 and 80-pin devices.  
**4:** Only 48, 64 and 80-pin devices have all eight PWM output pairs on dedicated pins. Refer to the “**Pin Diagrams**” for PWM pin availability on other packages.

# dsPIC33CK256MP508 FAMILY

**TABLE 1-1: PINOUT I/O DESCRIPTIONS (CONTINUED)**

Pin Name <sup>(1)</sup>	Pin Type	Buffer Type	PPS	Description
PGD1	I/O	ST	No	Data I/O pin for Programming/Debugging Communication Channel 1
PGC1	I	ST	No	Clock input pin for Programming/Debugging Communication Channel 1
PGD2	I/O	ST	No	Data I/O pin for Programming/Debugging Communication Channel 2
PGC2	I	ST	No	Clock input pin for Programming/Debugging Communication Channel 2
PGD3	I/O	ST	No	Data I/O pin for Programming/Debugging Communication Channel 3
PGC3	I	ST	No	Clock input pin for Programming/Debugging Communication Channel 3
MCLR	I/P	ST	No	Master Clear (Reset) input. This pin is an active-low Reset to the device.
AVDD	P	P	No	Positive supply for analog modules. This pin must be connected at all times.
AVSS	P	P	No	Ground reference for analog modules. This pin must be connected at all times.
VDD	P	—	No	Positive supply for peripheral logic and I/O pins
VSS	P	—	No	Ground reference for logic and I/O pins

**Legend:** CMOS = CMOS compatible input or output      Analog = Analog input      P = Power  
 ST = Schmitt Trigger input with CMOS levels      O = Output      I = Input  
 PPS = Peripheral Pin Select      TTL = TTL input buffer      DIG = Digital

- Note 1:** Not all pins are available in all package variants. See the “[Pin Diagrams](#)” section for pin availability.  
**2:** PWM4L and PWM4H pins are available on PPS as well as dedicated.  
**3:** SPI2 supports dedicated pins as well as PPS on 48, 64 and 80-pin devices.  
**4:** Only 48, 64 and 80-pin devices have all eight PWM output pairs on dedicated pins. Refer to the “[Pin Diagrams](#)” for PWM pin availability on other packages.

# dsPIC33CK256MP508 FAMILY

---

NOTES:



## 2.0 GUIDELINES FOR GETTING STARTED WITH HIGH-PERFORMANCE DIGITAL SIGNAL CONTROLLERS

### 2.1 Basic Connection Requirements

Getting started with the family devices of the dsPIC33CK256MP508 requires attention to a minimal set of device pin connections before proceeding with development. The following is a list of pin names which must always be connected:

- All VDD and VSS pins (see [Section 2.2 “Decoupling Capacitors”](#))
- All AVDD and AVSS pins regardless if ADC module is not used (see [Section 2.2 “Decoupling Capacitors”](#))
- MCLR pin (see [Section 2.3 “Master Clear \(MCLR\) Pin”](#))
- PGCx/PGDx pins used for In-Circuit Serial Programming™ (ICSP™) and debugging purposes (see [Section 2.4 “ICSP Pins”](#))
- OSCI and OSCO pins when an external oscillator source is used (see [Section 2.5 “External Oscillator Pins”](#))

### 2.2 Decoupling Capacitors

The use of decoupling capacitors on every pair of power supply pins, such as VDD, VSS, AVDD and AVSS is required.

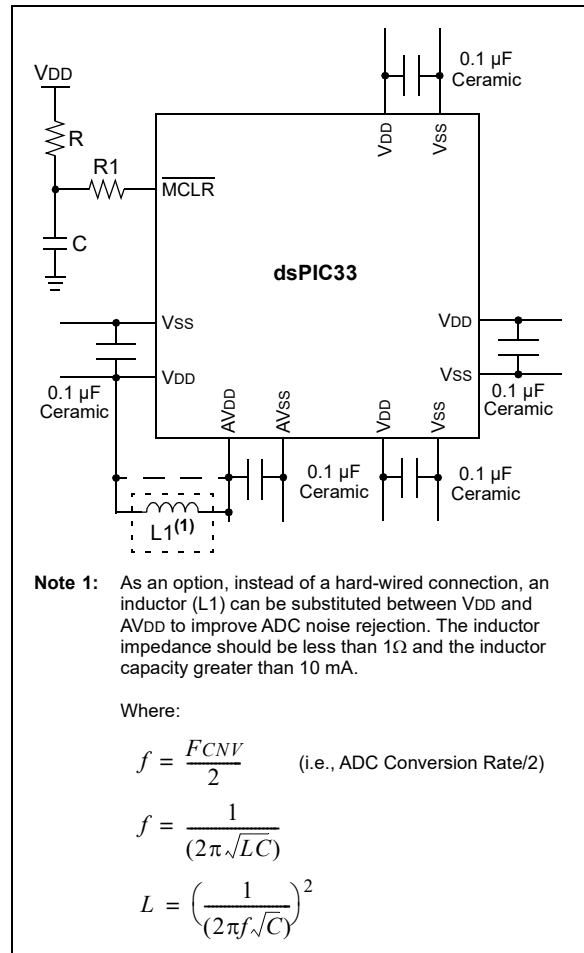
Consider the following criteria when using decoupling capacitors:

- **Value and type of capacitor:** Recommendation of 0.1 μF (100 nF), 10-20V. This capacitor should be a low-ESR and have resonance frequency in the range of 20 MHz and higher. It is recommended to use ceramic capacitors.
- **Placement on the Printed Circuit Board:** The decoupling capacitors should be placed as close to the pins as possible. It is recommended to place the capacitors on the same side of the board as the device. If space is constricted, the capacitor can be placed on another layer on the PCB using a via; however, ensure that the trace length from the pin to the capacitor is within one-quarter inch (6 mm) in length.
- **Handling high-frequency noise:** If the board is experiencing high-frequency noise, above tens of MHz, add a second ceramic-type capacitor in parallel to the above described decoupling capacitor. The value of the second capacitor can be in the range of 0.01 μF to 0.001 μF. Place this second capacitor next to the primary decoupling capacitor. In high-speed circuit designs, consider implementing a decade pair of capacitances as

close to the power and ground pins as possible. For example, 0.1 μF in parallel with 0.001 μF.

- **Maximizing performance:** On the board layout from the power supply circuit, run the power and return traces to the decoupling capacitors first, and then to the device pins. This ensures that the decoupling capacitors are first in the power chain. Equally important is to keep the trace length between the capacitor and the power pins to a minimum, thereby reducing PCB track inductance.

**FIGURE 2-1: RECOMMENDED MINIMUM CONNECTION**



#### 2.2.1 BULK CAPACITORS

On boards with power traces running longer than six inches in length, it is suggested to use a bulk capacitor for integrated circuits, including DSCs, to supply a local power source. The value of the bulk capacitor should be determined based on the trace resistance that connects the power supply source to the device and the maximum current drawn by the device in the application. In other words, select the bulk capacitor so that it meets the acceptable voltage sag at the device. Typical values range from 4.7 μF to 47 μF.

# dsPIC33CK256MP508 FAMILY

## 2.3 Master Clear ( $\overline{\text{MCLR}}$ ) Pin

The  $\overline{\text{MCLR}}$  pin provides two specific device functions:

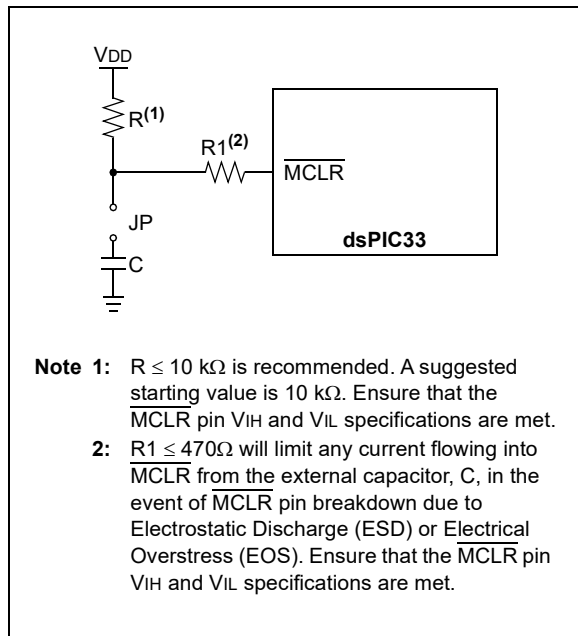
- Device Reset
- Device Programming and Debugging.

During device programming and debugging, the resistance and capacitance that can be added to the pin must be considered. Device programmers and debuggers drive the  $\overline{\text{MCLR}}$  pin. Consequently, specific voltage levels ( $V_{IH}$  and  $V_{IL}$ ) and fast signal transitions must not be adversely affected. Therefore, specific values of R and C will need to be adjusted based on the application and PCB requirements.

For example, as shown in Figure 2-2, it is recommended that the capacitor, C, be isolated from the  $\overline{\text{MCLR}}$  pin during programming and debugging operations.

Place the components, as shown in Figure 2-2, within one-quarter inch (6 mm) from the  $\overline{\text{MCLR}}$  pin.

**FIGURE 2-2: EXAMPLE OF  $\overline{\text{MCLR}}$  PIN CONNECTIONS**



## 2.4 ICSP Pins

The PGCx and PGDx pins are used for ICSP and debugging purposes. It is recommended to keep the trace length between the ICSP connector and the ICSP pins on the device as short as possible. If the ICSP connector is expected to experience an ESD event, a series resistor is recommended, with the value in the range of a few tens of Ohms, not to exceed 100 Ohms.

Pull-up resistors, series diodes and capacitors on the PGCx and PGDx pins are not recommended as they will interfere with the programmer/debugger communications to the device. If such discrete components are an application requirement, they should be removed from the circuit during programming and debugging. Alternatively, refer to the AC/DC characteristics and timing requirements information in the respective device Flash programming specification for information on capacitive loading limits and pin Voltage Input High ( $V_{IH}$ ) and Voltage Input Low ( $V_{IL}$ ) requirements.

Ensure that the “Communication Channel Select” (i.e., PGCx/PGDx pins) programmed into the device matches the physical connections for the ICSP to the programmer/debugger.

For more information regarding Microchip’s programmers and debuggers, refer to [Section 32.0 “Development Support”](#).

## 2.5 External Oscillator Pins

When the Primary Oscillator (POSC) circuit is used to connect a crystal oscillator, special care and consideration is needed to ensure proper operation. The POSC circuit should be tested across the environmental conditions that the end product is intended to be used. The load capacitors specified in the crystal oscillator data sheet can be used as a starting point, however, the parasitic capacitance from the PCB traces can affect the circuit, and the values may need to be altered to ensure proper start-up and operation. Excessive trace length and other physical interaction can lead to poor signal quality. Poorly tuned oscillator circuits can have reduced amplitude, incorrect frequency (runt pulses), distorted waveforms and long start-up times that may result in unpredictable application behavior, such as instruction misexecution, illegal op code fetch, etc. Ensure that the crystal oscillator circuit is at full amplitude and correct frequency before the system begins to execute code. In planning the application’s routing and I/O assignments, ensure that adjacent port pins, and other signals in close proximity to the oscillator do not have high frequencies, short rise and fall times and other similar noise. For further information on the primary oscillator see [Section 9.4 “Primary Oscillator \(POSC\)”](#).

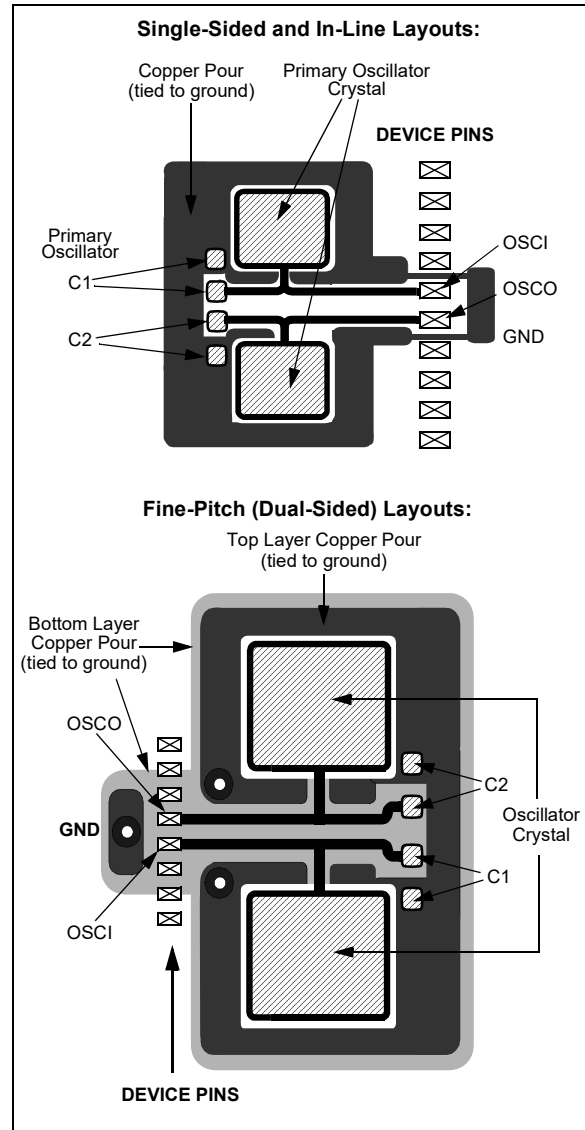
## 2.6 External Oscillator Layout Guidance

Use best practices during PCB layout to ensure robust start-up and operation. The oscillator circuit should be placed on the same side of the board as the device. Also, place the oscillator circuit close to the respective oscillator pins, not exceeding one-half inch (12 mm) distance between them. The load capacitors should be placed next to the oscillator itself, on the same side of the board. Use a grounded copper pour around the oscillator circuit to isolate them from surrounding circuits. The grounded copper pour should be routed directly to the MCU ground. Do not run any signal traces or power traces inside the ground pour. If using a two-sided board, avoid any traces on the other side of the board where the crystal is placed. Suggested layouts are shown in Figure 2-3. With fine-pitch packages, it is not always possible to completely surround the pins and components. A suitable solution is to tie the broken guard sections to a mirrored ground layer. In all cases, the guard trace(s) must be returned to ground.

For additional information and design guidance on oscillator circuits, please refer to these Microchip Application Notes, available at the Microchip website ([www.microchip.com](http://www.microchip.com)):

- AN943, “Practical PICmicro® Oscillator Analysis and Design”
- AN949, “Making Your Oscillator Work”
- AN1798, “Crystal Selection for Low-Power Secondary Oscillator”

**FIGURE 2-3: SUGGESTED PLACEMENT OF THE OSCILLATOR CIRCUIT**



# dsPIC33CK256MP508 FAMILY

## 2.7 Oscillator Value Conditions on Device Start-up

If the PLL of the target device is enabled and configured for the device start-up oscillator, the maximum oscillator source frequency must be limited to a certain frequency (see [Section 9.0 “Oscillator with High-Frequency PLL”](#)) to comply with device PLL start-up conditions. This means that if the external oscillator frequency is outside this range, the application must start up in the FRC mode first. The default PLL settings after a POR with an oscillator frequency outside this range will violate the device operating speed.

Once the device powers up, the application firmware can initialize the PLL SFRs, CLKDIV and PLLFBD, to a suitable value, and then perform a clock switch to the Oscillator + PLL clock source. Note that clock switching must be enabled in the device Configuration Word.

## 2.8 Unused I/Os

Unused I/O pins should be configured as outputs and driven to a logic low state.

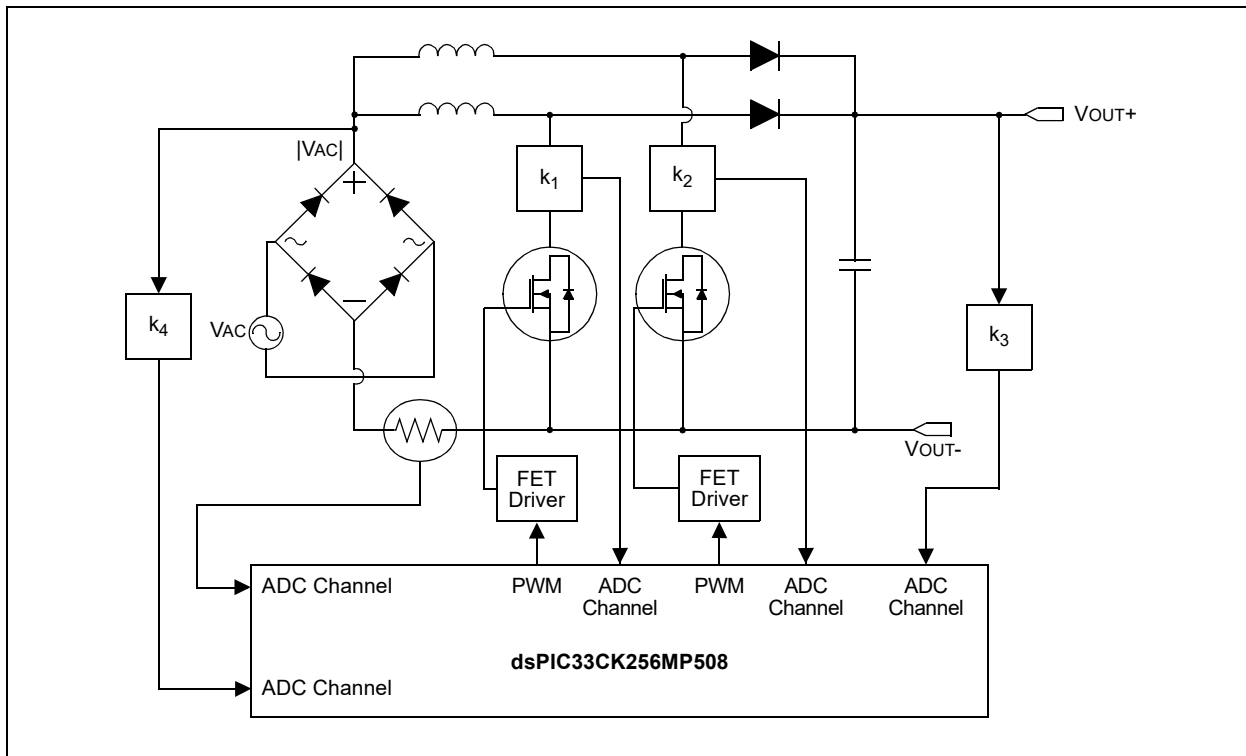
Alternatively, connect a 1k to 10k resistor between Vss and unused pins, and drive the output to logic low.

## 2.9 Targeted Applications

- Power Factor Correction (PFC):
  - Interleaved PFC
  - Critical Conduction PFC
  - Bridgeless PFC
- DC/DC Converters:
  - Buck, Boost, Forward, Flyback, Push-Pull
  - Half/Full-Bridge
  - Phase-Shift Full-Bridge
  - Resonant Converters
- DC/AC:
  - Half/Full-Bridge Inverter
  - Resonant Inverter
- Motor Control
  - BLDC
  - PMSM
  - SR
  - ACIM

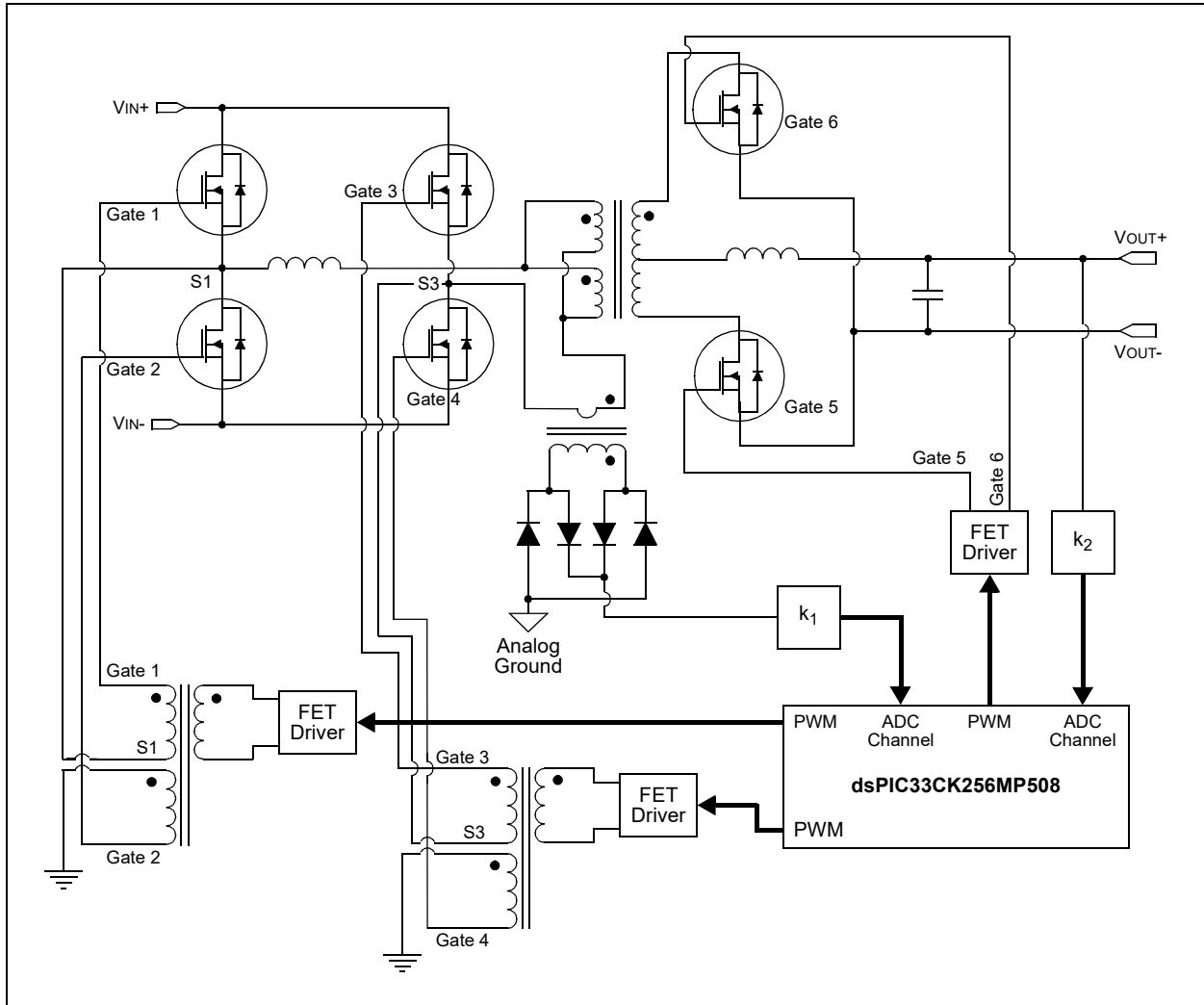
Examples of typical application connections are shown in [Figure 2-4](#) through [Figure 2-6](#).

FIGURE 2-4: INTERLEAVED PFC



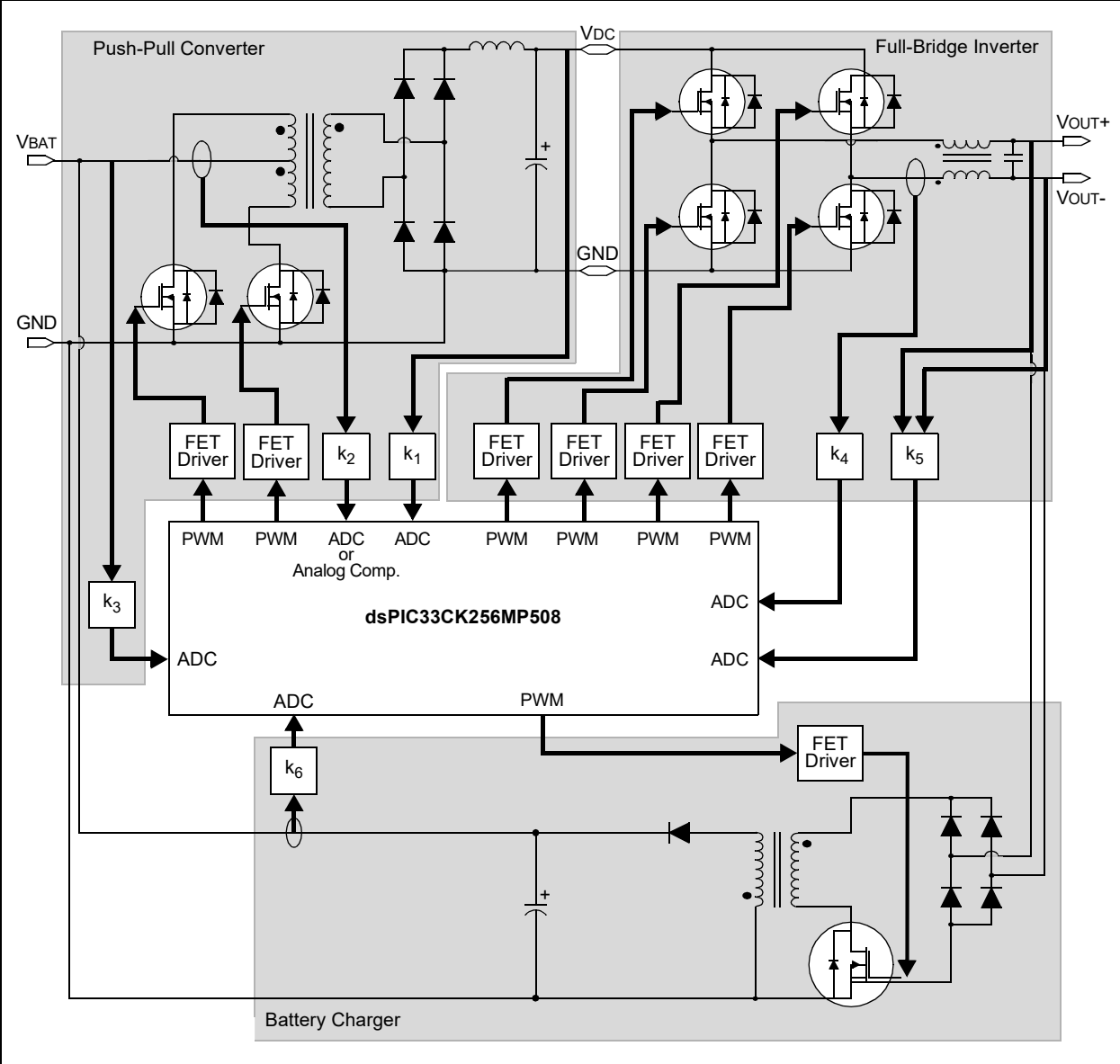
# dsPIC33CK256MP508 FAMILY

FIGURE 2-5: PHASE-SHIFTED FULL-BRIDGE CONVERTER



# dsPIC33CK256MP508 FAMILY

FIGURE 2-6: OFF-LINE UPS



## 3.0 CPU

**Note 1:** This data sheet summarizes the features of the dsPIC33CK256MP508 family of devices. It is not intended to be a comprehensive reference source. To complement the information in this data sheet, refer to “**Enhanced CPU**” ([www.microchip.com/DS70005158](http://www.microchip.com/DS70005158)) in the “*dsPIC33/PIC24 Family Reference Manual*”.

**2:** Some registers and associated bits described in this section may not be available on all devices. Refer to **Section 4.0 “Memory Organization”** in this data sheet for device-specific register and bit information.

The dsPIC33CK256MP508 family CPU has a 16-bit (data) modified Harvard architecture with an enhanced instruction set, including significant support for Digital Signal Processing (DSP). The CPU has a 24-bit instruction word with a variable length opcode field. The Program Counter (PC) is 23 bits wide and addresses up to 4M x 24 bits of user program memory space.

An instruction prefetch mechanism helps maintain throughput and provides predictable execution. Most instructions execute in a single-cycle effective execution rate, with the exception of instructions that change the program flow, the double-word move (`MOV.D`) instruction, PSV accesses and the table instructions. Overhead-free program loop constructs are supported using the `DO` and `REPEAT` instructions, both of which are interruptible at any point.

## 3.1 Registers

The dsPIC33CK256MP508 devices have sixteen, 16-bit Working registers in the programmer’s model. Each of the Working registers can act as a Data, Address or Address Offset register. The 16th Working register (W15) operates as a Software Stack Pointer for interrupts and calls.

In addition, the dsPIC33CK256MP508 devices include four Alternate Working register sets, which consist of W0 through W14. The Alternate Working registers can be made persistent to help reduce the saving and restoring of register content during Interrupt Service Routines (ISRs). The Alternate Working registers can be assigned to a specific Interrupt Priority Level (IPL1 through IPL6) by configuring the `CTXTx[2:0]` bits in the `FALTREG` Configuration register. The Alternate Working registers can also be accessed manually by using the `CTXTSWP` instruction. The `CCTXI[2:0]` and `MCTXI[2:0]` bits in the `CTXTSTAT` register can be used to identify the current, and most recent, manually selected Working register sets.

## 3.2 Instruction Set

The instruction set for dsPIC33CK256MP508 devices has two classes of instructions: the MCU class of instructions and the DSP class of instructions. These two instruction classes are seamlessly integrated into the architecture and execute from a single execution unit. The instruction set includes many addressing modes and was designed for optimum C compiler efficiency.

## 3.3 Data Space Addressing

The base Data Space can be addressed as up to 4K words or 8 Kbytes, and is split into two blocks, referred to as X and Y data memory. Each memory block has its own independent Address Generation Unit (AGU). The MCU class of instructions operates solely through the X memory AGU, which accesses the entire memory map as one linear Data Space. Certain DSP instructions operate through the X and Y AGUs to support dual operand reads, which splits the data address space into two parts. The X and Y Data Space boundary is device-specific.

The upper 32 Kbytes of the Data Space memory map can optionally be mapped into Program Space (PS) at any 16K program word boundary. The program-to-Data Space mapping feature, known as Program Space Visibility (PSV), lets any instruction access Program Space as if it were Data Space. Refer to “**Data Memory**” (DS70595) in the “*dsPIC33/PIC24 Family Reference Manual*” for more details on PSV and table accesses.

On dsPIC33CK256MP508 family devices, overhead-free circular buffers (Modulo Addressing) are supported in both X and Y address spaces. The Modulo Addressing removes the software boundary checking overhead for DSP algorithms. The X AGU Circular Addressing can be used with any of the MCU class of instructions. The X AGU also supports Bit-Reversed Addressing to greatly simplify input or output data re-ordering for radix-2 FFT algorithms.

## 3.4 Addressing Modes

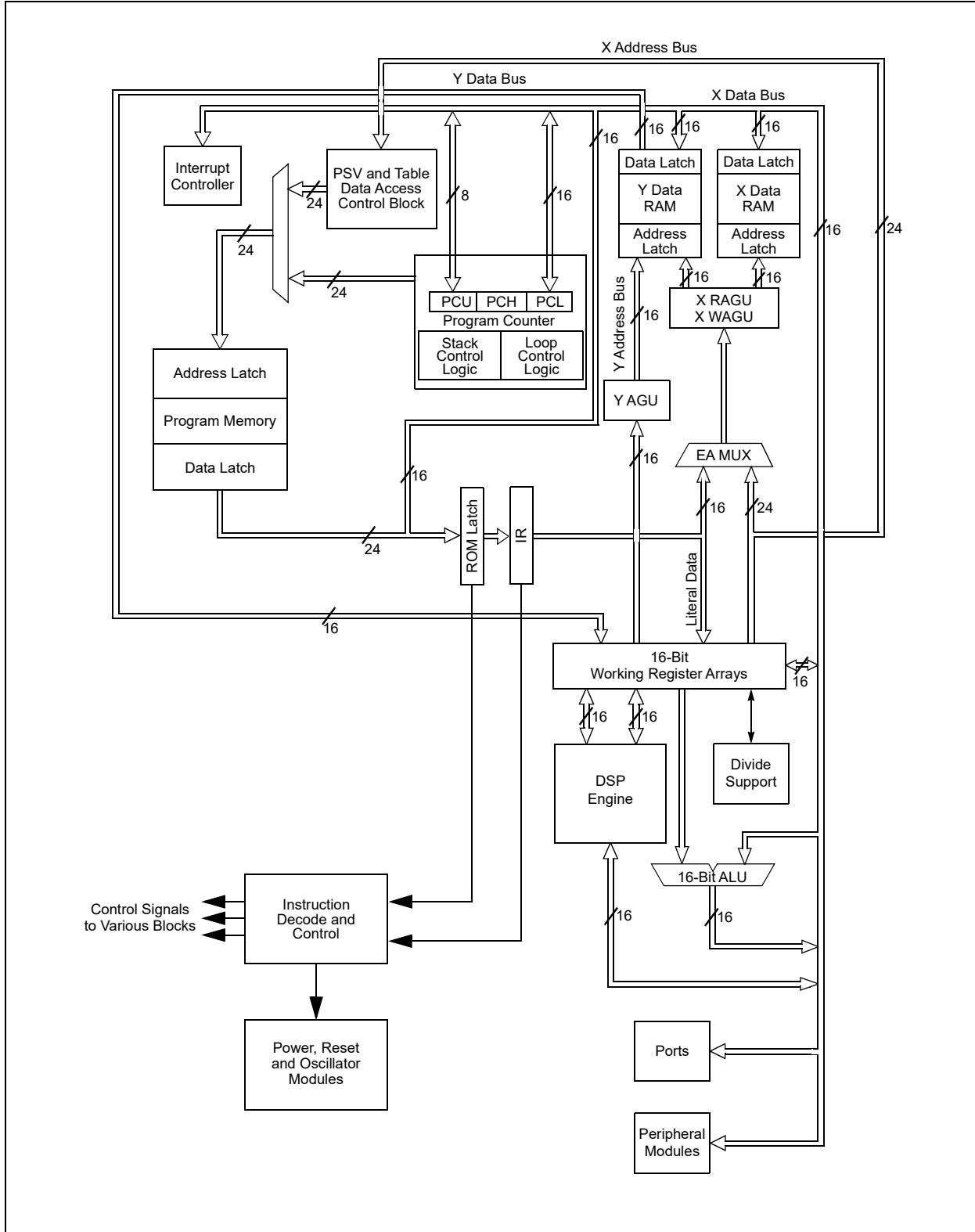
The CPU supports these addressing modes:

- Inherent (no operand)
- Relative
- Literal
- Memory Direct
- Register Direct
- Register Indirect

Each instruction is associated with a predefined addressing mode group, depending upon its functional requirements. As many as six addressing modes are supported for each instruction.

# dsPIC33CK256MP508 FAMILY

FIGURE 3-1: dsPIC33CK256MP508 FAMILY CPU BLOCK DIAGRAM





# dsPIC33CK256MP508 FAMILY

## 3.4.1 PROGRAMMER'S MODEL

The programmer's model for the dsPIC33CK256MP508 family is shown in [Figure 3-2](#). All registers in the programmer's model are memory-mapped and can be manipulated directly by instructions. [Table 3-1](#) lists a description of each register.

In addition to the registers contained in the programmer's model, the dsPIC33CK256MP508 devices contain control registers for Modulo Addressing, Bit-Reversed Addressing and interrupts. These registers are described in subsequent sections of this document.

All registers associated with the programmer's model are memory-mapped, as shown in [Figure 3-2](#).

**TABLE 3-1: PROGRAMMER'S MODEL REGISTER DESCRIPTIONS**

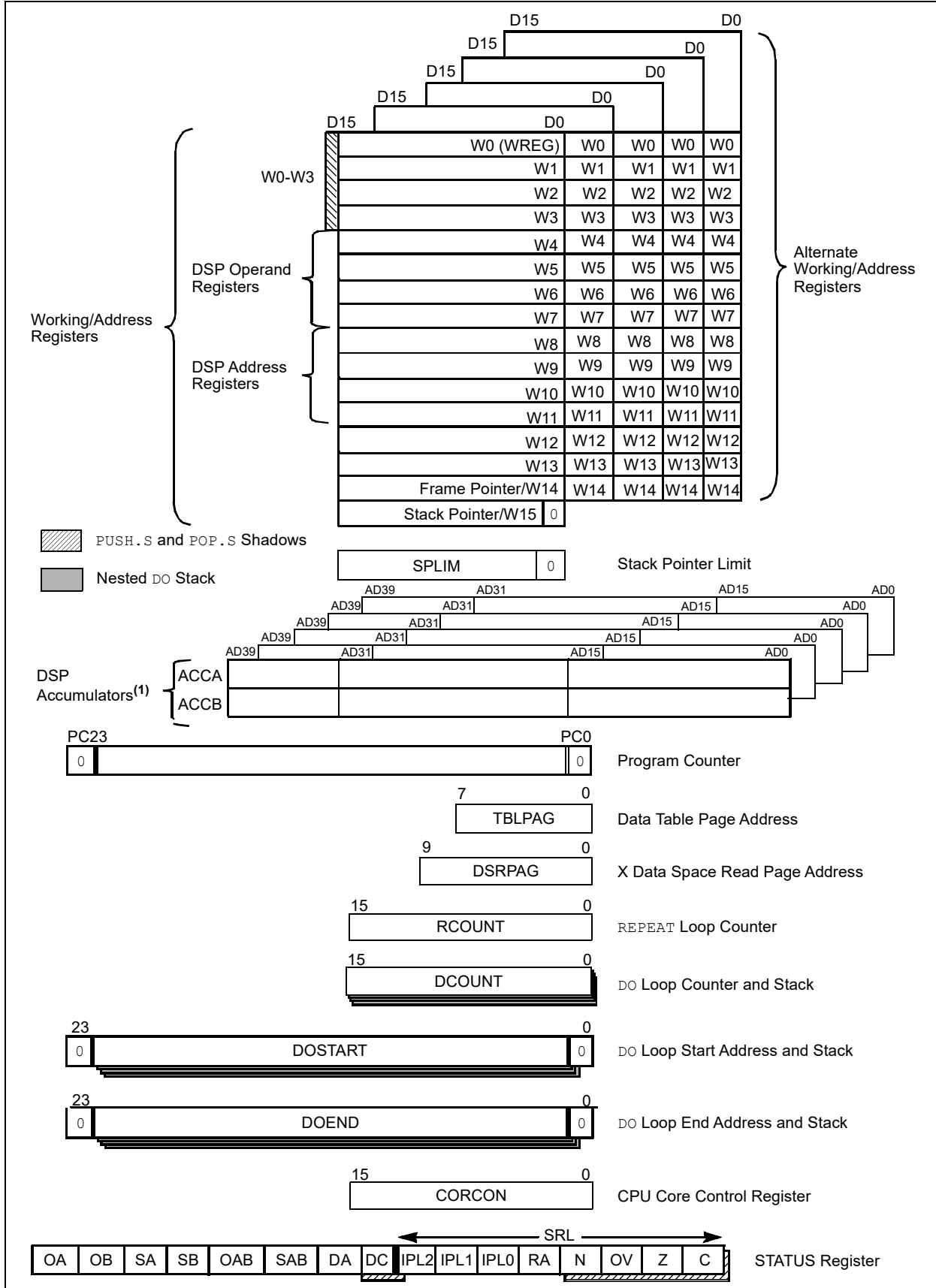
Register(s) Name	Description
W0 through W15 <sup>(1)</sup>	Working Register Array
W0 through W14 <sup>(1)</sup>	Alternate Working Register Array 1
W0 through W14 <sup>(1)</sup>	Alternate Working Register Array 2
W0 through W14 <sup>(1)</sup>	Alternate Working Register Array 3
W0 through W14 <sup>(1)</sup>	Alternate Working Register Array 4
ACCA, ACCB	40-Bit DSP Accumulators (Additional 4 Alternate Accumulators)
PC	23-Bit Program Counter
SR	ALU and DSP Engine STATUS Register
SPLIM	Stack Pointer Limit Value Register
TBLPAG	Table Memory Page Address Register
DSRPAG	Extended Data Space (EDS) Read Page Register
RCOUNT	REPEAT Loop Counter Register
DCOUNT	DO Loop Counter Register
DOSTARTH, DOSTARTL <sup>(2)</sup>	DO Loop Start Address Register (High and Low)
DOENDH, DOENDL	DO Loop End Address Register (High and Low)
CORCON	Contains DSP Engine, DO Loop Control and Trap Status bits

**Note 1:** Memory-mapped W0 through W14 represent the value of the register in the currently active CPU context.

**Note 2:** The DOSTARTH and DOSTARTL registers are read-only.

# dsPIC33CK256MP508 FAMILY

FIGURE 3-2: PROGRAMMER'S MODEL



# dsPIC33CK256MP508 FAMILY

---

## 3.4.2 CPU RESOURCES

Many useful resources are provided on the main product page of the Microchip website for the devices listed in this data sheet. This product page contains the latest updates and additional information.

### 3.4.2.1 Key Resources

- **“Enhanced CPU”** (DS70005158) in the *“dsPIC33/PIC24 Family Reference Manual”*
- Code Samples
- Application Notes
- Software Libraries
- Webinars
- All related *“dsPIC33/PIC24 Family Reference Manual”* Sections
- Development Tools

# dsPIC33CK256MP508 FAMILY

## 3.4.3 CPU CONTROL REGISTERS

### REGISTER 3-1: SR: CPU STATUS REGISTER

R/W-0	R/W-0	R/W-0	R/W-0	R/C-0	R/C-0	R-0	R/W-0
OA	OB	SA <sup>(3)</sup>	SB <sup>(3)</sup>	OAB	SAB	DA	DC
bit 15						bit 8	

R/W-0 <sup>(2)</sup>	R/W-0 <sup>(2)</sup>	R/W-0 <sup>(2)</sup>	R-0	R/W-0	R/W-0	R/W-0	R/W-0
IPL2 <sup>(1)</sup>	IPL1 <sup>(1)</sup>	IPL0 <sup>(1)</sup>	RA	N	OV	Z	C
bit 7						bit 0	

<b>Legend:</b>	C = Clearable bit
R = Readable bit	W = Writable bit
-n = Value at POR	'1' = Bit is set
	U = Unimplemented bit, read as '0'
	'0' = Bit is cleared
	x = Bit is unknown

- bit 15      **OA:** Accumulator A Overflow Status bit  
 1 = Accumulator A has overflowed  
 0 = Accumulator A has not overflowed
- bit 14      **OB:** Accumulator B Overflow Status bit  
 1 = Accumulator B has overflowed  
 0 = Accumulator B has not overflowed
- bit 13      **SA:** Accumulator A Saturation 'Sticky' Status bit<sup>(3)</sup>  
 1 = Accumulator A is saturated or has been saturated at some time  
 0 = Accumulator A is not saturated
- bit 12      **SB:** Accumulator B Saturation 'Sticky' Status bit<sup>(3)</sup>  
 1 = Accumulator B is saturated or has been saturated at some time  
 0 = Accumulator B is not saturated
- bit 11      **OAB:** OA || OB Combined Accumulator Overflow Status bit  
 1 = Accumulator A or B has overflowed  
 0 = Neither Accumulator A or B has overflowed
- bit 10      **SAB:** SA || SB Combined Accumulator 'Sticky' Status bit  
 1 = Accumulator A or B is saturated or has been saturated at some time  
 0 = Neither Accumulator A or B is saturated
- bit 9        **DA:** DO Loop Active bit  
 1 = DO loop is in progress  
 0 = DO loop is not in progress
- bit 8        **DC:** MCU ALU Half Carry/Borrow bit  
 1 = A carry-out from the 4th low-order bit (for byte-sized data) or 8th low-order bit (for word-sized data) of the result occurred  
 0 = No carry-out from the 4th low-order bit (for byte-sized data) or 8th low-order bit (for word-sized data) of the result occurred

- Note 1:** The IPL[2:0] bits are concatenated with the IPL[3] bit (CORCON[3]) to form the CPU Interrupt Priority Level. The value in parentheses indicates the IPL, if IPL[3] = 1. User interrupts are disabled when IPL[3] = 1.
- 2:** The IPL[2:0] Status bits are read-only when the NSTDIS bit (INTCON1[15]) = 1.
- 3:** A data write to the SR register can modify the SA and SB bits by either a data write to SA and SB or by clearing the SAB bit. To avoid a possible SA or SB bit write race condition, the SA and SB bits should not be modified using bit operations.

# dsPIC33CK256MP508 FAMILY

## REGISTER 3-1: SR: CPU STATUS REGISTER (CONTINUED)

bit 7-5	<b>IPL[2:0]:</b> CPU Interrupt Priority Level Status bits <sup>(1,2)</sup> 111 = CPU Interrupt Priority Level is 7 (15); user interrupts are disabled 110 = CPU Interrupt Priority Level is 6 (14) 101 = CPU Interrupt Priority Level is 5 (13) 100 = CPU Interrupt Priority Level is 4 (12) 011 = CPU Interrupt Priority Level is 3 (11) 010 = CPU Interrupt Priority Level is 2 (10) 001 = CPU Interrupt Priority Level is 1 (9) 000 = CPU Interrupt Priority Level is 0 (8)
bit 4	<b>RA:</b> REPEAT Loop Active bit 1 = REPEAT loop is in progress 0 = REPEAT loop is not in progress
bit 3	<b>N:</b> MCU ALU Negative bit 1 = Result was negative 0 = Result was non-negative (zero or positive)
bit 2	<b>OV:</b> MCU ALU Overflow bit This bit is used for signed arithmetic (two's complement). It indicates an overflow of the magnitude that causes the sign bit to change state. 1 = Overflow occurred for signed arithmetic (in this arithmetic operation) 0 = No overflow occurred
bit 1	<b>Z:</b> MCU ALU Zero bit 1 = An operation that affects the Z bit has set it at some time in the past 0 = The most recent operation that affects the Z bit has cleared it (i.e., a non-zero result)
bit 0	<b>C:</b> MCU ALU Carry/Borrow bit 1 = A carry-out from the Most Significant bit of the result occurred 0 = No carry-out from the Most Significant bit of the result occurred

- Note 1:** The IPL[2:0] bits are concatenated with the IPL[3] bit (CORCON[3]) to form the CPU Interrupt Priority Level. The value in parentheses indicates the IPL, if IPL[3] = 1. User interrupts are disabled when IPL[3] = 1.
- 2:** The IPL[2:0] Status bits are read-only when the NSTDIS bit (INTCON1[15]) = 1.
- 3:** A data write to the SR register can modify the SA and SB bits by either a data write to SA and SB or by clearing the SAB bit. To avoid a possible SA or SB bit write race condition, the SA and SB bits should not be modified using bit operations.

# dsPIC33CK256MP508 FAMILY

## REGISTER 3-2: CORCON: CORE CONTROL REGISTER

R/W-0	U-0	R/W-0	R/W-0	R/W-0	R-0	R-0	R-0
VAR	—	US1	US0	EDT <sup>(1)</sup>	DL2	DL1	DL0
bit 15						bit 8	

R/W-0	R/W-0	R/W-1	R/W-0	R/C-0	R-0	R/W-0	R/W-0
SATA	SATB	SATDW	ACCSAT	IPL3 <sup>(2)</sup>	SFA	RND	IF
bit 7						bit 0	

<b>Legend:</b>	C = Clearable bit		
R = Readable bit	W = Writable bit	U = Unimplemented bit, read as '0'	
-n = Value at POR	'1' = Bit is set	'0' = Bit is cleared	x = Bit is unknown

- bit 15      **VAR:** Variable Exception Processing Latency Control bit  
             1 = Variable exception processing latency is enabled  
             0 = Fixed exception processing latency is enabled
- bit 14      **Unimplemented:** Read as '0'
- bit 13-12   **US[1:0]:** DSP Multiply Unsigned/Signed Control bits  
             11 = Reserved  
             10 = DSP engine multiplies are mixed sign  
             01 = DSP engine multiplies are unsigned  
             00 = DSP engine multiplies are signed
- bit 11      **EDT:** Early DO Loop Termination Control bit<sup>(1)</sup>  
             1 = Terminates executing DO loop at the end of the current loop iteration  
             0 = No effect
- bit 10-8    **DL[2:0]:** DO Loop Nesting Level Status bits  
             111 = Seven DO loops are active  
             ...  
             001 = One DO loop is active  
             000 = Zero DO loops are active
- bit 7       **SATA:** ACCA Saturation Enable bit  
             1 = Accumulator A saturation is enabled  
             0 = Accumulator A saturation is disabled
- bit 6       **SATB:** ACCB Saturation Enable bit  
             1 = Accumulator B saturation is enabled  
             0 = Accumulator B saturation is disabled
- bit 5       **SATDW:** Data Space Write from DSP Engine Saturation Enable bit  
             1 = Data Space write saturation is enabled  
             0 = Data Space write saturation is disabled
- bit 4       **ACCSAT:** Accumulator Saturation Mode Select bit  
             1 = 9.31 saturation (super saturation)  
             0 = 1.31 saturation (normal saturation)
- bit 3       **IPL3:** CPU Interrupt Priority Level Status bit 3<sup>(2)</sup>  
             1 = CPU Interrupt Priority Level is greater than 7  
             0 = CPU Interrupt Priority Level is 7 or less

- Note 1:** This bit is always read as '0'.
- Note 2:** The IPL3 bit is concatenated with the IPL[2:0] bits (SR[7:5]) to form the CPU Interrupt Priority Level.

# dsPIC33CK256MP508 FAMILY

## REGISTER 3-2: CORCON: CORE CONTROL REGISTER (CONTINUED)

- bit 2      **SFA:** Stack Frame Active Status bit  
 1 = Stack frame is active; W14 and W15 address 0x0000 to 0xFFFF, regardless of DSRPAG  
 0 = Stack frame is not active; W14 and W15 address the base Data Space
- bit 1      **RND:** Rounding Mode Select bit  
 1 = Biased (conventional) rounding is enabled  
 0 = Unbiased (convergent) rounding is enabled
- bit 0      **IF:** Integer or Fractional Multiplier Mode Select bit  
 1 = Integer mode is enabled for DSP multiply  
 0 = Fractional mode is enabled for DSP multiply

- Note 1:** This bit is always read as '0'.  
**Note 2:** The IPL3 bit is concatenated with the IPL[2:0] bits (SR[7:5]) to form the CPU Interrupt Priority Level.

## REGISTER 3-3: MSTRPR: EDS BUS INITIATOR PRIORITY CONTROL REGISTER

U-0	U-0	U-0	U-0	U-0	U-0	U-0	U-0
—	—	—	—	—	—	—	—
bit 15							bit 8

U-0	U-0	R/W-0	R/W-0	U-0	U-0	U-0	R/W-0
—	—	DMAPR	CANPR	—	—	—	NVMPR
bit 7							bit 0

<b>Legend:</b>			
R = Readable bit	W = Writable bit	U = Unimplemented bit, read as '0'	
-n = Value at POR	'1' = Bit is set	'0' = Bit is cleared	x = Bit is unknown

- bit 15-6      **Unimplemented:** Read as '0'
- bit 5      **DMAPR:** Modify DMA Controller Bus Initiator Priority Relative to CPU bit  
 1 = Raises DMA Controller bus Initiator priority to above that of the CPU  
 0 = No change to DMA Controller bus Initiator priority
- bit 4      **CANPR:** Modify CAN1 Bus Initiator Priority Relative to CPU bit  
 1 = Raises CAN1 bus Initiator priority to above that of the CPU  
 0 = No change to CAN1 bus Initiator priority
- bit 3-1      **Unimplemented:** Read as '0'
- bit 0      **NVMPR:** Modify NVM Controller Bus Initiator Priority Relative to CPU bit  
 1 = Raises NVM Controller bus Initiator priority to above that of the CPU  
 0 = No change to NVM Controller bus Initiator priority

# dsPIC33CK256MP508 FAMILY

## REGISTER 3-4: CTXTSTAT: CPU W REGISTER CONTEXT STATUS REGISTER

U-0	U-0	U-0	U-0	U-0	R-0	R-0	R-0
—	—	—	—	—	CCTXI2	CCTXI1	CCTXI0
bit 15					bit 8		

U-0	U-0	U-0	U-0	U-0	R-0	R-0	R-0
—	—	—	—	—	MCTXI2	MCTXI1	MCTXI0
bit 7					bit 0		

### Legend:

R = Readable bit	W = Writable bit	U = Unimplemented bit, read as '0'
-n = Value at POR	'1' = Bit is set	'0' = Bit is cleared
		x = Bit is unknown

bit 15-11      **Unimplemented:** Read as '0'

bit 10-8      **CCTXI[2:0]:** Current (W Register) Context Identifier bits

111 = Reserved

•  
•  
•

100 = Alternate Working Register Set 4 is currently in use

011 = Alternate Working Register Set 3 is currently in use

010 = Alternate Working Register Set 2 is currently in use

001 = Alternate Working Register Set 1 is currently in use

000 = Default register set is currently in use

bit 7-3      **Unimplemented:** Read as '0'

bit 2-0      **MCTXI[2:0]:** Manual (W Register) Context Identifier bits

111 = Reserved

•  
•  
•

100 = Alternate Working Register Set 4 was most recently manually selected

011 = Alternate Working Register Set 3 was most recently manually selected

010 = Alternate Working Register Set 2 was most recently manually selected

001 = Alternate Working Register Set 1 was most recently manually selected

000 = Default register set was most recently manually selected



# dsPIC33CK256MP508 FAMILY

## 3.4.4 ARITHMETIC LOGIC UNIT (ALU)

The dsPIC33CK256MP508 family ALU is 16 bits wide and is capable of addition, subtraction, bit shifts and logic operations. Unless otherwise mentioned, arithmetic operations are two's complement in nature. Depending on the operation, the ALU can affect the values of the Carry (C), Zero (Z), Negative (N), Overflow (OV) and Digit Carry (DC) Status bits in the SR register. The C and DC Status bits operate as Borrow and Digit Borrow bits, respectively, for subtraction operations.

The ALU can perform 8-bit or 16-bit operations, depending on the mode of the instruction that is used. Data for the ALU operation can come from the W register array or data memory, depending on the addressing mode of the instruction. Likewise, output data from the ALU can be written to the W register array or a data memory location.

Refer to the “16-Bit MCU and DSC Programmer's Reference Manual” (DS70000157) for information on the SR bits affected by each instruction.

The core CPU incorporates hardware support for both multiplication and division. This includes a dedicated hardware multiplier and support hardware for 16-bit divisor division.

### 3.4.4.1 Multiplier

Using the high-speed, 17-bit x 17-bit multiplier, the ALU supports unsigned, signed or mixed-sign operation in several MCU multiplication modes:

- 16-bit x 16-bit signed
- 16-bit x 16-bit unsigned
- 16-bit signed x 5-bit (literal) unsigned
- 16-bit signed x 16-bit unsigned
- 16-bit unsigned x 5-bit (literal) unsigned
- 16-bit unsigned x 16-bit signed
- 8-bit unsigned x 8-bit unsigned

### 3.4.4.2 Divider

The divide block supports 32-bit/16-bit and 16-bit/16-bit signed and unsigned integer divide operations with the following data sizes:

- 32-bit signed/16-bit signed divide
- 32-bit unsigned/16-bit unsigned divide
- 16-bit signed/16-bit signed divide
- 16-bit unsigned/16-bit unsigned divide

The 16-bit signed and unsigned `DIV` instructions can specify any W register for both the 16-bit divisor (`Wn`) and any W register (aligned) pair (`W(m + 1):Wm`) for the 32-bit dividend. The divide algorithm takes one cycle per bit of divisor, so both 32-bit/16-bit and 16-bit/16-bit instructions take the same number of cycles to execute. There are additional instructions: `DIV2` and `DIVF2`. Divide instructions will complete in six cycles.

## 3.4.5 DSP ENGINE

The DSP engine consists of a high-speed 17-bit x 17-bit multiplier, a 40-bit barrel shifter and a 40-bit adder/subtractor (with two target accumulators, round and saturation logic).

The DSP engine can also perform inherent accumulator-to-accumulator operations that require no additional data. These instructions are, `ADD`, `SUB`, `NEG`, `MIN` and `MAX`.

The DSP engine has options selected through bits in the CPU Core Control register (`CORCON`), as listed below:

- Fractional or integer DSP multiply (`IF`)
- Signed, unsigned or mixed-sign DSP multiply (`USx`)
- Conventional or convergent rounding (`RND`)
- Automatic saturation on/off for `ACCA` (`SATA`)
- Automatic saturation on/off for `ACCB` (`SATB`)
- Automatic saturation on/off for writes to data memory (`SATDW`)
- Accumulator Saturation mode selection (`ACCSAT`)

**TABLE 3-2: DSP INSTRUCTIONS SUMMARY**

Instruction	Algebraic Operation	ACC Write-Back
CLR	$A = 0$	Yes
ED	$A = (x - y)^2$	No
EDAC	$A = A + (x - y)^2$	No
MAC	$A = A + (x \cdot y)$	Yes
MAC	$A = A + x^2$	No
MOVSAC	No change in A	Yes
MPY	$A = x \cdot y$	No
MPY	$A = x^2$	No
MPY, N	$A = -x \cdot y$	No
MSC	$A = A - x \cdot y$	Yes

# dsPIC33CK256MP508 FAMILY

---

NOTES:

# dsPIC33CK256MP508 FAMILY

## 4.0 MEMORY ORGANIZATION

**Note:** This data sheet summarizes the features of the dsPIC33CK256MP508 family of devices. It is not intended to be a comprehensive reference source. To complement the information in this data sheet, refer to “dsPIC33/PIC24 Program Memory” ([www.microchip.com/DS70000613](http://www.microchip.com/DS70000613)) in the “dsPIC33/PIC24 Family Reference Manual”.

The dsPIC33CK256MP508 family architecture features separate program and data memory spaces, and buses. This architecture also allows the direct access of program memory from the Data Space (DS) during code execution.

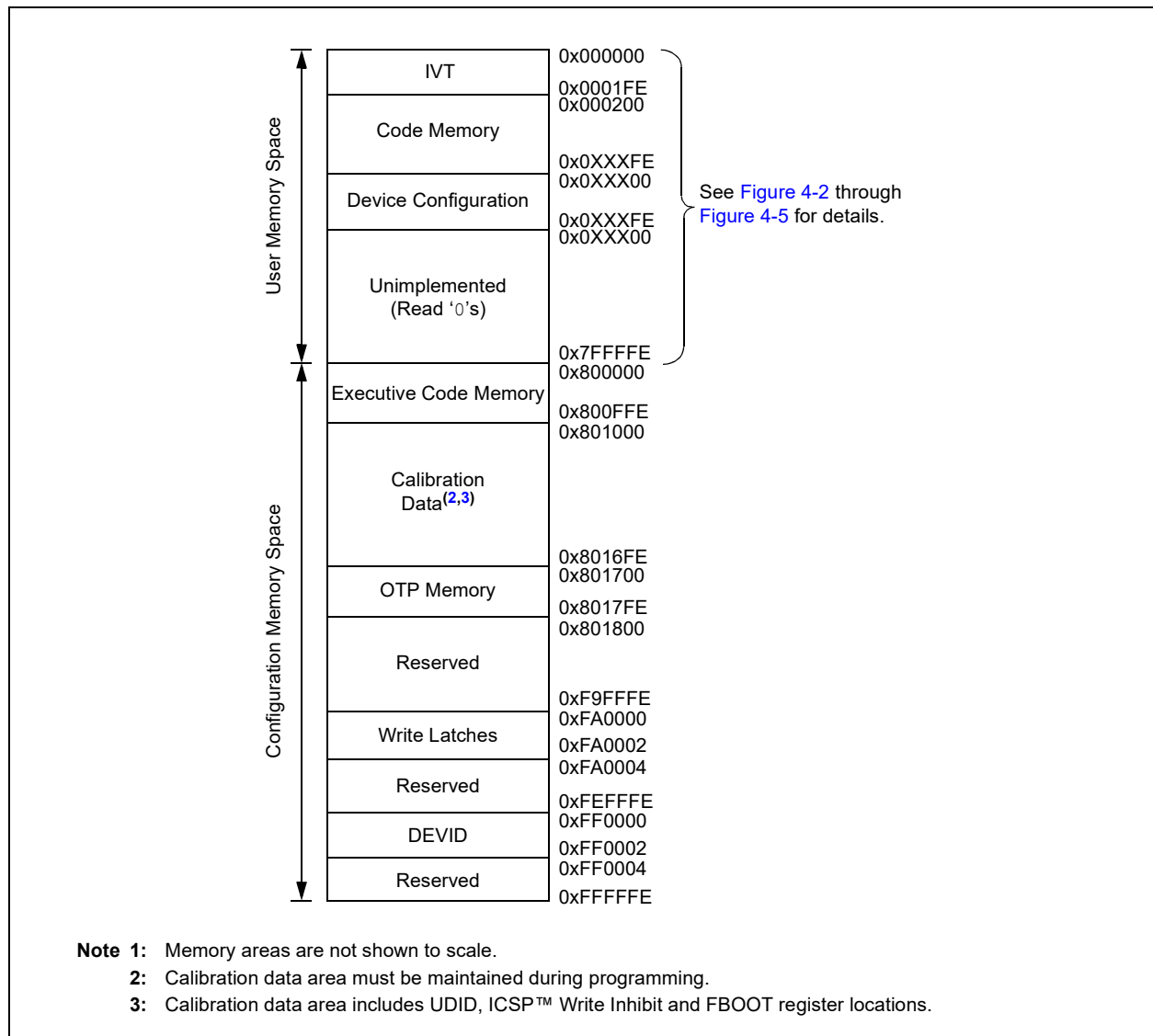
## 4.1 Program Address Space

The program address memory space of the dsPIC33CK256MP508 family devices is 4M instructions. The space is addressable by a 24-bit value derived either from the 23-bit PC during program execution, or from table operation or Data Space remapping, as described in [Section 4.5.5 “Interfacing Program and Data Memory Spaces”](#).

User application access to the program memory space is restricted to the lower half of the address range (0x000000 to 0x7FFFFFFF). The exception is the use of TBLRD operations, which use TBLPAG[7] to permit access to calibration data and Device ID sections of the configuration memory space.

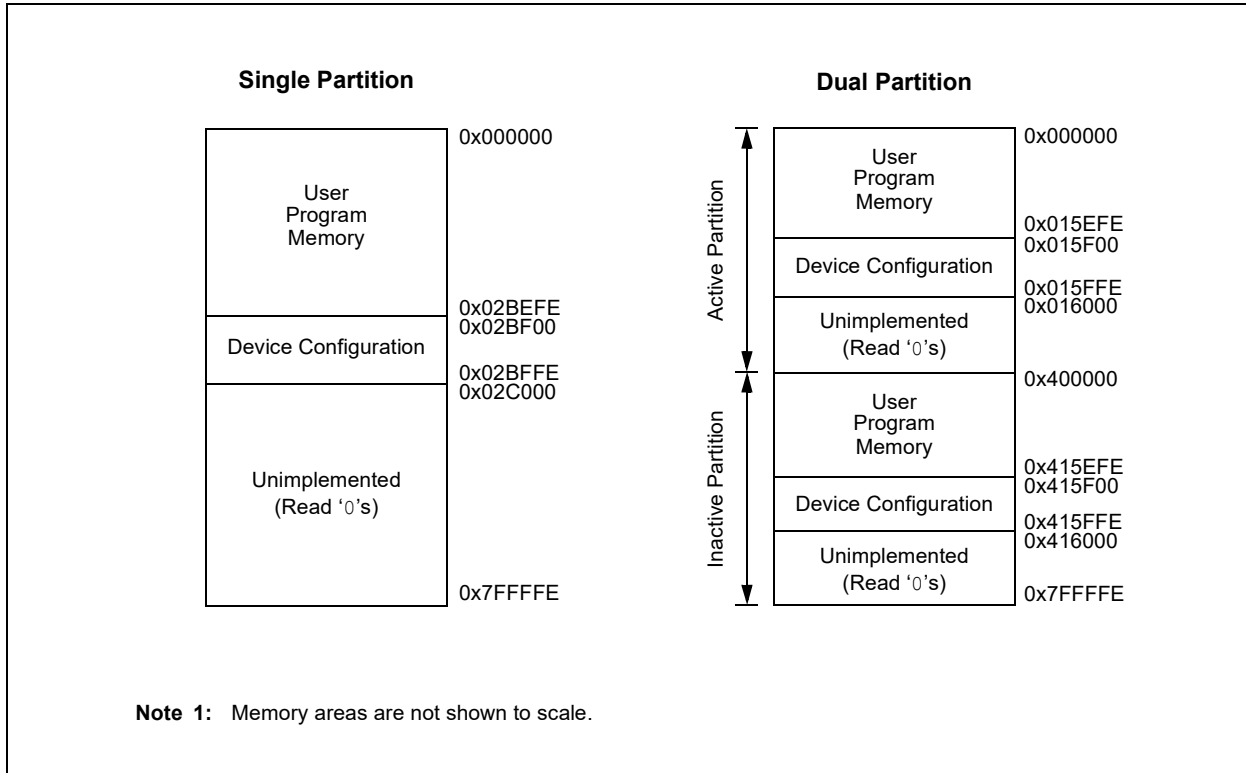
The program memory maps for dsPIC33CK256MP508 devices are shown in [Figure 4-1](#) through [Figure 4-5](#).

**FIGURE 4-1: PROGRAM MEMORY MAP FOR dsPIC33CKXXXMP50X/20X DEVICES<sup>(1)</sup>**

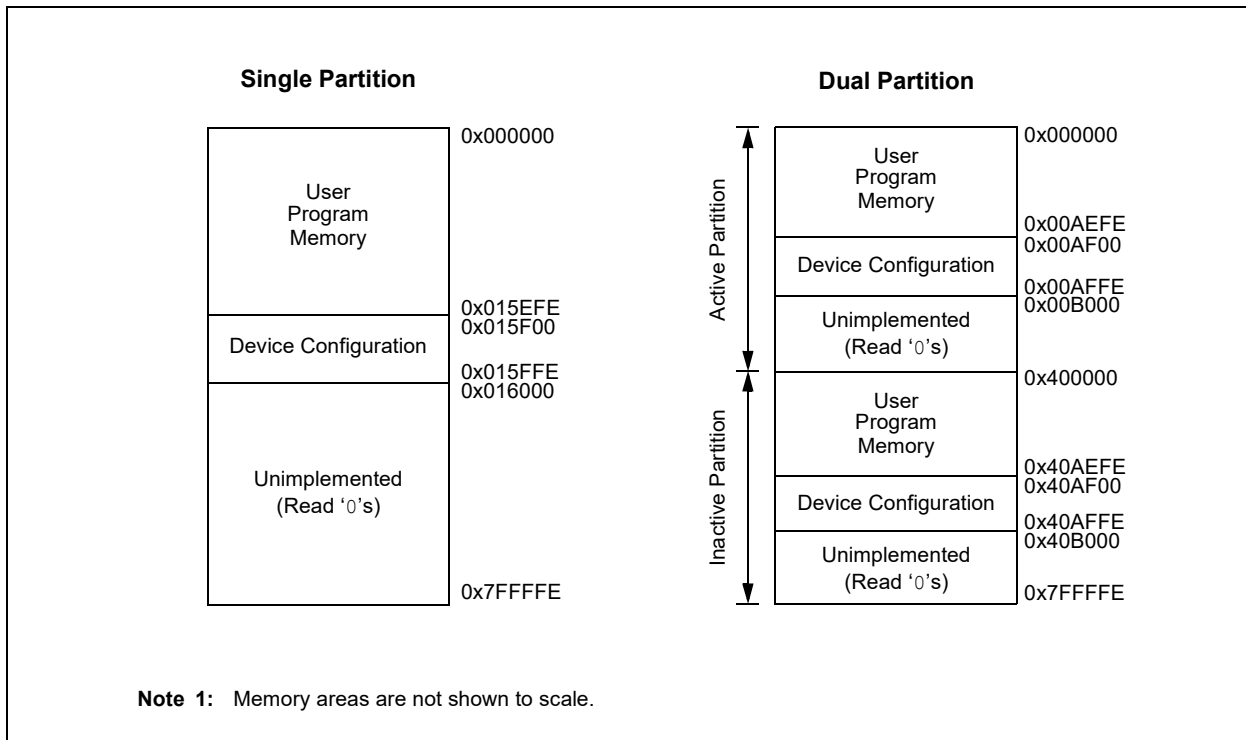


# dsPIC33CK256MP508 FAMILY

**FIGURE 4-2: PROGRAM MEMORY MAP FOR dsPIC33CK256MP50/20X DEVICES<sup>(1)</sup>**

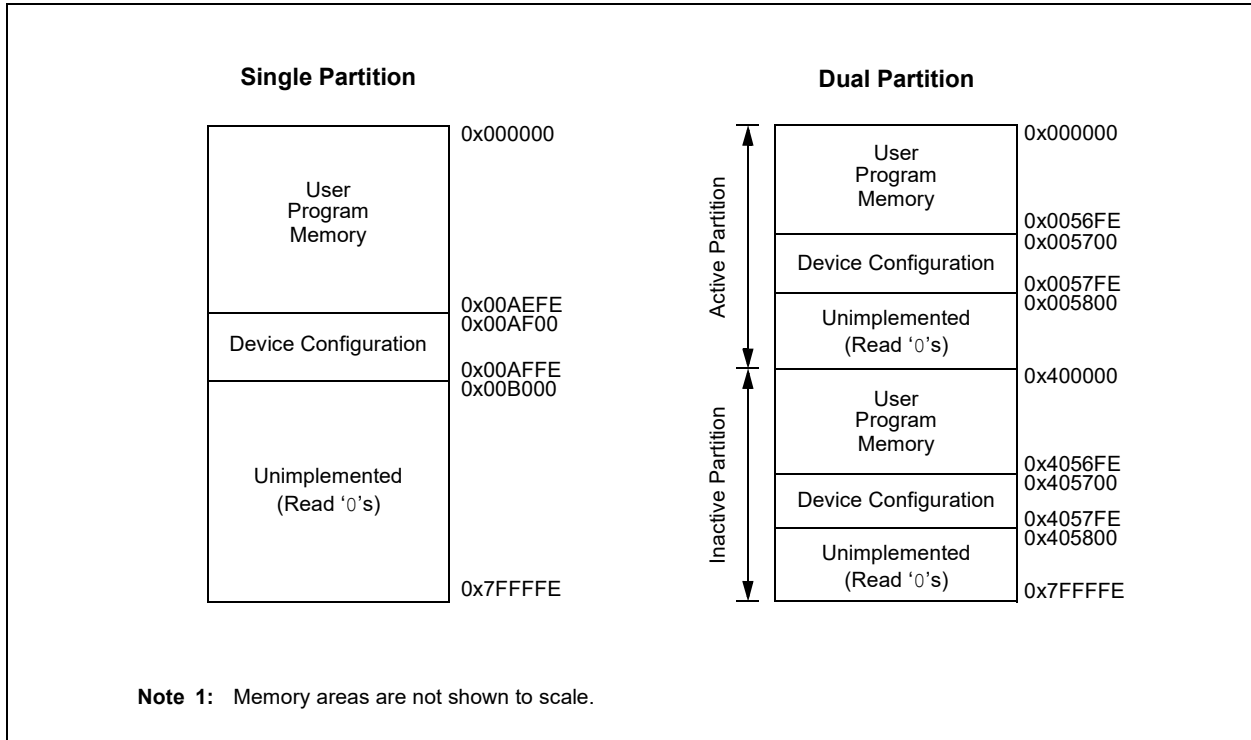


**FIGURE 4-3: PROGRAM MEMORY MAP FOR dsPIC33CK128MP50X/20X DEVICES<sup>(1)</sup>**

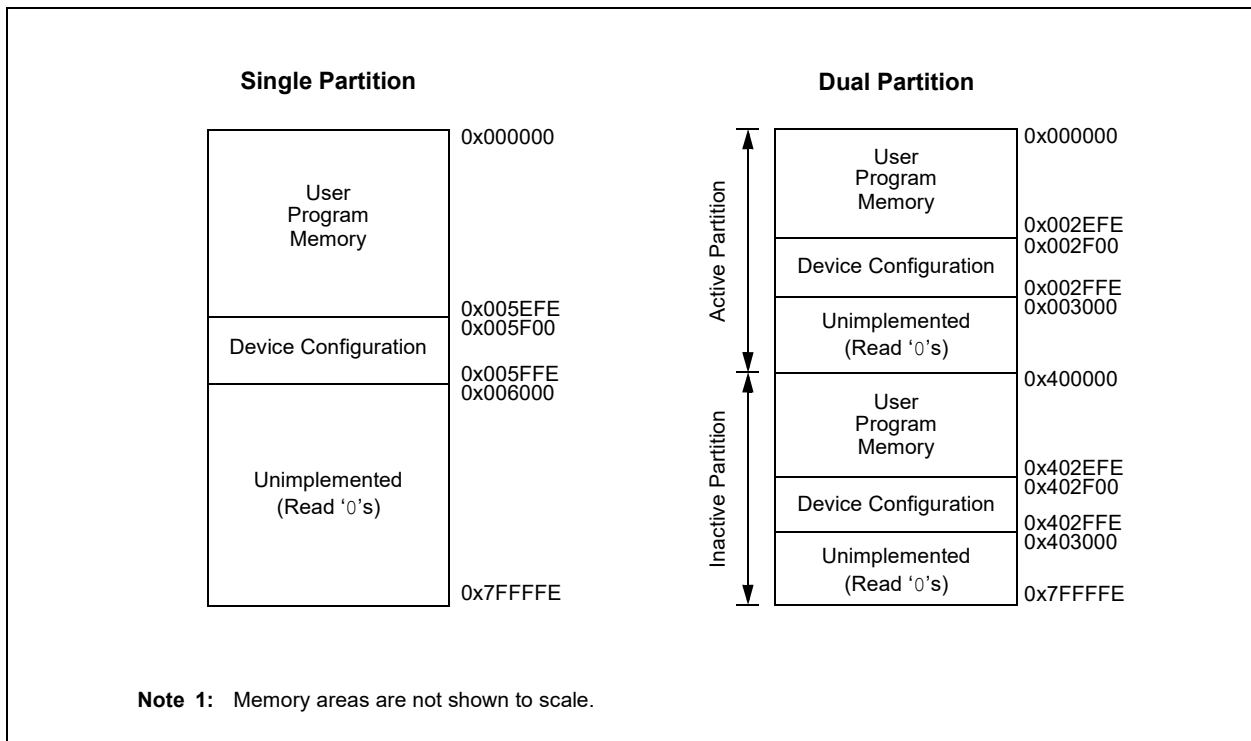


# dsPIC33CK256MP508 FAMILY

**FIGURE 4-4: PROGRAM MEMORY MAP FOR dsPIC33CK64MP50X/20X DEVICES<sup>(1)</sup>**



**FIGURE 4-5: PROGRAM MEMORY MAP FOR dsPIC33CK32MP50X/20X DEVICES<sup>(1)</sup>**



# dsPIC33CK256MP508 FAMILY

## 4.1.1 PROGRAM MEMORY ORGANIZATION

The program memory space is organized in word-addressable blocks. Although it is treated as 24 bits wide, it is more appropriate to think of each address of the program memory as a lower and upper word, with the upper byte of the upper word being unimplemented. The lower word always has an even address, while the upper word has an odd address (Figure 4-6).

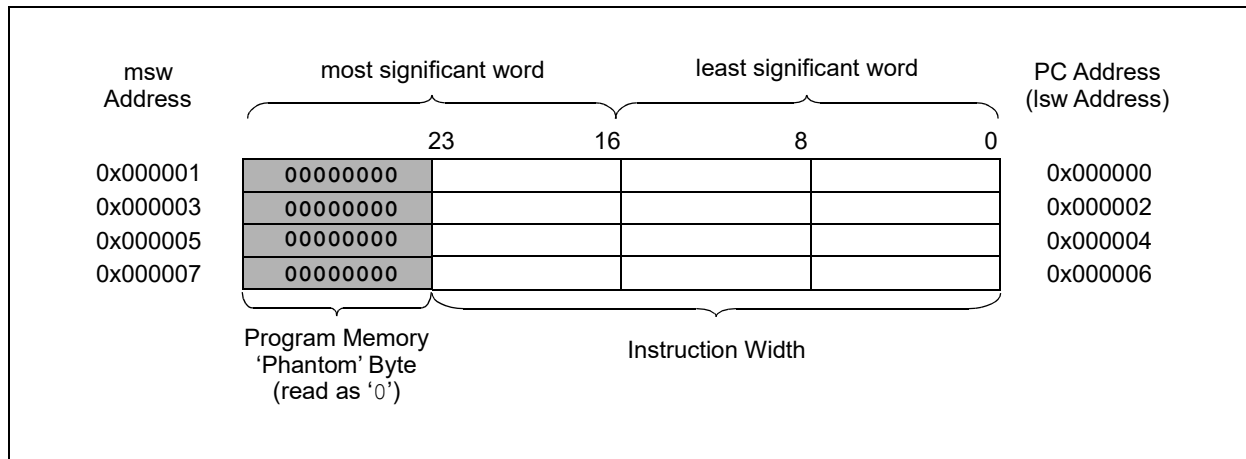
Program memory addresses are always word-aligned on the lower word, and addresses are incremented or decremented, by two, during code execution. This arrangement provides compatibility with data memory space addressing and makes data in the program memory space accessible.

## 4.1.2 INTERRUPT AND TRAP VECTORS

All dsPIC33CK256MP508 family devices reserve the addresses between 0x000000 and 0x000200 for hard-coded program execution vectors. A hardware Reset vector is provided to redirect code execution from the default value of the PC on device Reset to the actual start of code. A GOTO instruction is programmed by the user application at address, 0x000000, of Flash memory, with the actual address for the start of code at address, 0x000002, of Flash memory.

A more detailed discussion of the Interrupt Vector Tables (IVTs) is provided in Section 7.0 “Interrupt Controller”.

**FIGURE 4-6: PROGRAM MEMORY ORGANIZATION**



## 4.1.3 UNIQUE DEVICE IDENTIFIER (UDID)

All dsPIC33CK256MP508 family devices are individually encoded during final manufacturing with a Unique Device Identifier or UDID. The UDID cannot be erased by a bulk erase command or any other user-accessible means. This feature allows for manufacturing traceability of Microchip Technology devices in applications where this is a requirement. It may also be used by the application manufacturer for any number of things that may require unique identification, such as:

- Tracking the device
- Unique serial number
- Unique security key

The UDID comprises five 24-bit program words. When taken together, these fields form a unique 120-bit identifier.

The UDID is stored in five read-only locations, located between 0x801200 and 0x801208 in the device configuration space. [Table 4-1](#) lists the addresses of the Identifier Words and shows their contents.

**TABLE 4-1: UDID ADDRESSES**

UDID	Address	Description
UDID1	0x801200	UDID Word 1
UDID2	0x801202	UDID Word 2
UDID3	0x801204	UDID Word 3
UDID4	0x801206	UDID Word 4
UDID5	0x801208	UDID Word 5

## 4.2 Data Address Space

The dsPIC33CK256MP508 family CPU has a separate 16-bit wide data memory space. The Data Space is accessed using separate Address Generation Units (AGUs) for read and write operations. The data memory maps are shown in [Figure 4-7](#), [Figure 4-8](#) and [Figure 4-9](#).

All Effective Addresses (EAs) in the data memory space are 16 bits wide and point to bytes within the Data Space. This arrangement gives a base Data Space address range of 64 Kbytes or 32K words.

The lower half of the data memory space (i.e., when  $EA[15] = 0$ ) is used for implemented memory addresses, while the upper half ( $EA[15] = 1$ ) is reserved for the Program Space Visibility (PSV).

The dsPIC33CK256MP508 family devices implement up to 16 Kbytes of data memory. If an EA points to a location outside of this area, an all-zero word or byte is returned.

## 4.2.1 DATA SPACE WIDTH

The data memory space is organized in byte-addressable, 16-bit wide blocks. Data are aligned in data memory and registers as 16-bit words, but all Data Space EAs resolve to bytes. The Least Significant Bytes (LSBs) of each word have even addresses, while the Most Significant Bytes (MSBs) have odd addresses.

## 4.2.2 DATA MEMORY ORGANIZATION AND ALIGNMENT

To maintain backward compatibility with PIC<sup>®</sup> MCU devices and improve Data Space memory usage efficiency, the dsPIC33CK256MP508 family instruction set supports both word and byte operations. As a consequence of byte accessibility, all Effective Address calculations are internally scaled to step through word-aligned memory. For example, the core recognizes that Post-Modified Register Indirect Addressing mode [Ws++] results in a value of  $Ws + 1$  for byte operations and  $Ws + 2$  for word operations.

A data byte read, reads the complete word that contains the byte, using the LSB of any EA to determine which byte to select. The selected byte is placed onto the LSB of the data path. That is, data memory and registers are organized as two parallel, byte-wide entities with shared (word) address decode, but separate write lines. Data byte writes only write to the corresponding side of the array or register that matches the byte address.

All word accesses must be aligned to an even address. Misaligned word data fetches are not supported, so care must be taken when mixing byte and word operations, or translating from 8-bit MCU code. If a misaligned read or write is attempted, an address error trap is generated. If the error occurred on a read, the instruction underway is completed. If the error occurred on a write, the instruction is executed but the write does not occur. In either case, a trap is then executed, allowing the system and/or user application to examine the machine state prior to execution of the address Fault.

All byte loads into any W register are loaded into the LSB; the MSB is not modified.

A Sign-Extend (SE) instruction is provided to allow user applications to translate 8-bit signed data to 16-bit signed values. Alternatively, for 16-bit unsigned data, user applications can clear the MSB of any W register by executing a Zero-Extend (ZE) instruction on the appropriate address.

# dsPIC33CK256MP508 FAMILY

---

## 4.2.3 SFR SPACE

The first four Kbytes of the Near Data Space, from 0x0000 to 0x0FFF, is primarily occupied by Special Function Registers (SFRs). These are used by the dsPIC33CK256MP508 family core and peripheral modules for controlling the operation of the device.

SFRs are distributed among the modules that they control and are generally grouped together by module. Much of the SFR space contains unused addresses; these are read as '0'.

<p><b>Note:</b> The actual set of peripheral features and interrupts varies by the device. Refer to the corresponding device tables and pinout diagrams for device-specific information.</p>
--

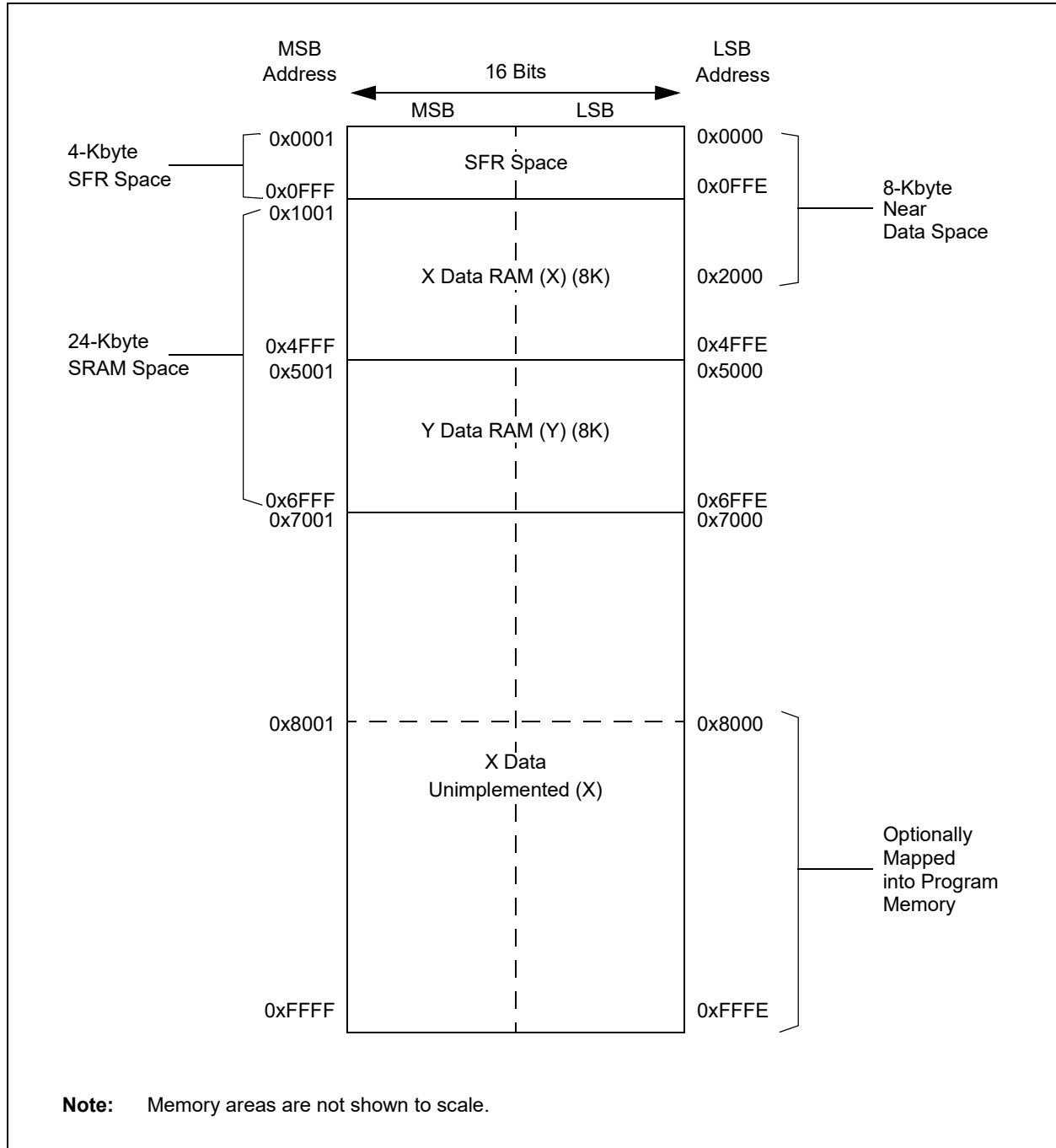
## 4.2.4 NEAR DATA SPACE

The 8-Kbyte area, between 0x0000 and 0x1FFF, is referred to as the Near Data Space. Locations in this space are directly addressable through a 13-bit absolute address field within all memory direct instructions. Additionally, the whole Data Space is addressable using *MOV* instructions, which support Memory Direct Addressing mode with a 16-bit address field, or by using Indirect Addressing mode using a Working register as an Address Pointer.



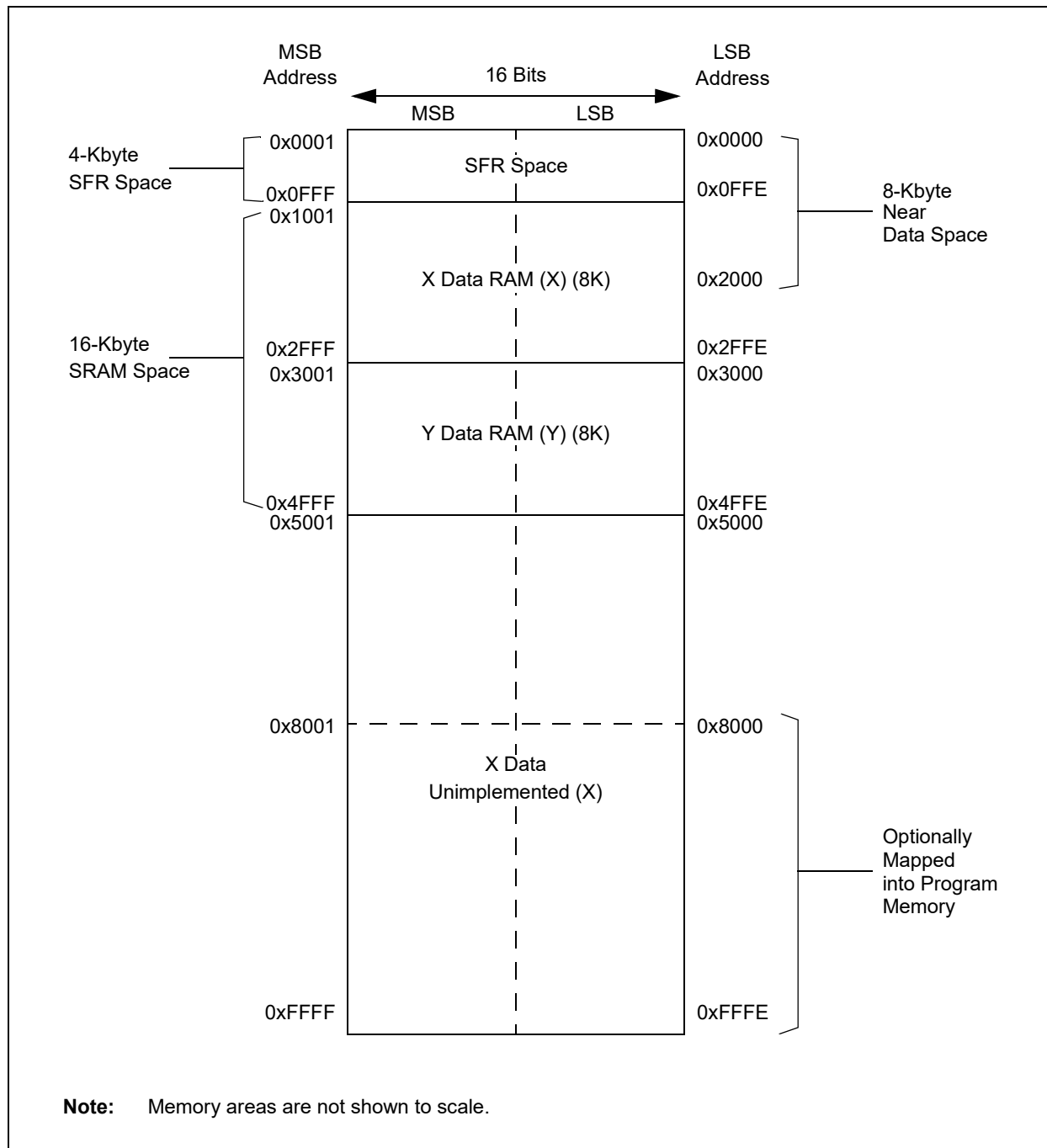
# dsPIC33CK256MP508 FAMILY

**FIGURE 4-7: DATA MEMORY MAP FOR dsPIC33CK256MPX0X DEVICES**



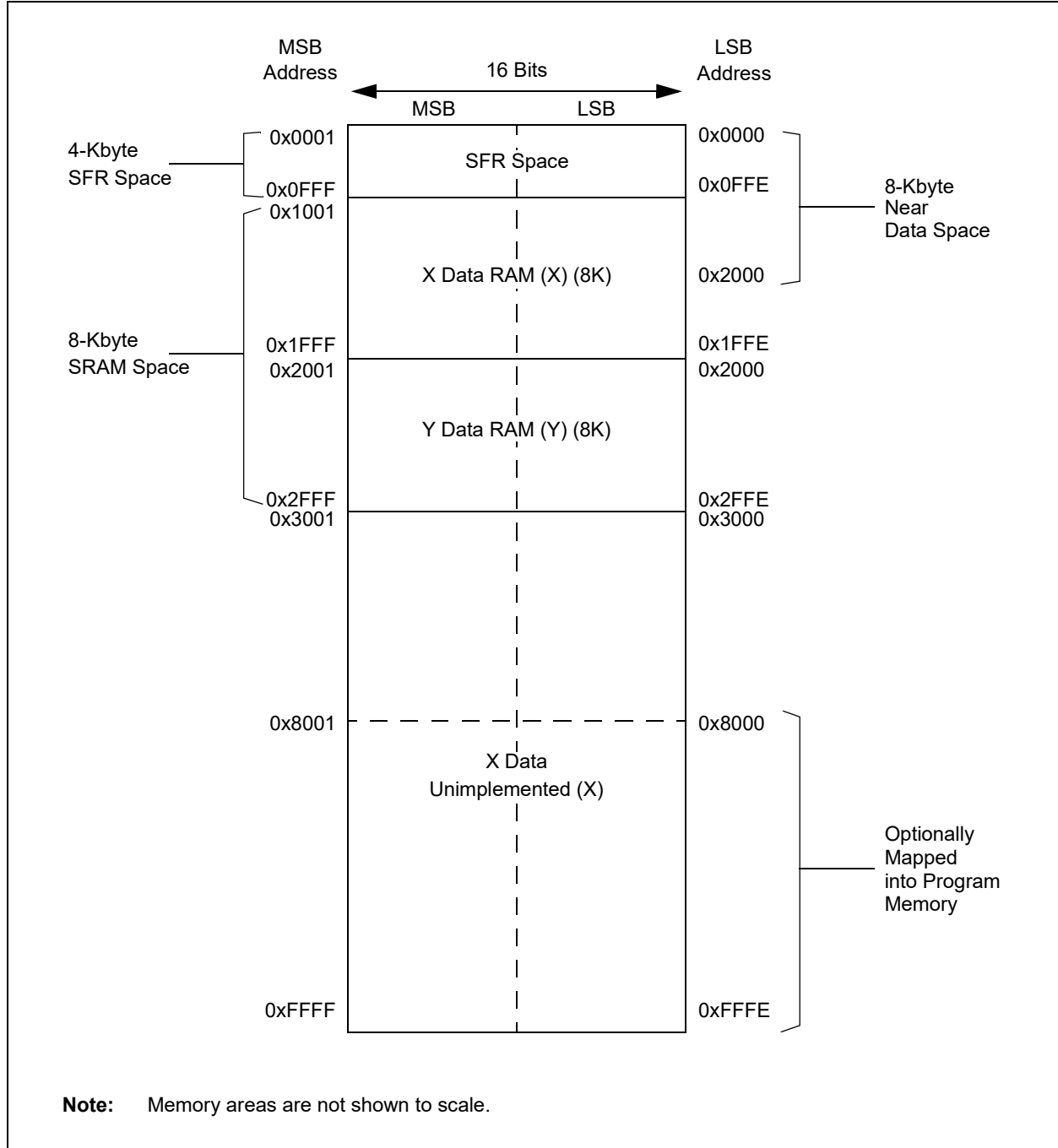
# dsPIC33CK256MP508 FAMILY

**FIGURE 4-8: DATA MEMORY MAP FOR dsPIC33CK128MPX0X DEVICES**



# dsPIC33CK256MP508 FAMILY

**FIGURE 4-9: DATA MEMORY MAP FOR dsPIC33CK64MPX0X AND dsPIC33CK32MPX0X DEVICES**



# dsPIC33CK256MP508 FAMILY

## 4.2.5 X AND Y DATA SPACES

The dsPIC33CK256MP508 family core has two Data Spaces, X and Y. These Data Spaces can be considered either separate (for some DSP instructions) or as one unified linear address range (for MCU instructions). The Data Spaces are accessed using two Address Generation Units (AGUs) and separate data paths. This feature allows certain instructions to concurrently fetch two words from RAM, thereby enabling efficient execution of DSP algorithms, such as Finite Impulse Response (FIR) filtering and Fast Fourier Transform (FFT).

The X Data Space is used by all instructions and supports all addressing modes. X Data Space has separate read and write data buses. The X read data bus is the read data path for all instructions that view Data Space as combined X and Y address space. It is also the X data prefetch path for the dual operand DSP instructions (MAC class).

The Y Data Space is used in concert with the X Data Space by the MAC class of instructions (CLR, ED, EDAC, MAC, MOV SAC, MPY, MPY.N and MSC) to provide two concurrent data read paths.

Both the X and Y Data Spaces support Modulo Addressing mode for all instructions, subject to addressing mode restrictions. Bit-Reversed Addressing mode is only supported for writes to X Data Space.

All data memory writes, including in DSP instructions, view Data Space as combined X and Y address space. The boundary between the X and Y Data Spaces is device-dependent and is not user-programmable.

## 4.3 BIST Overview

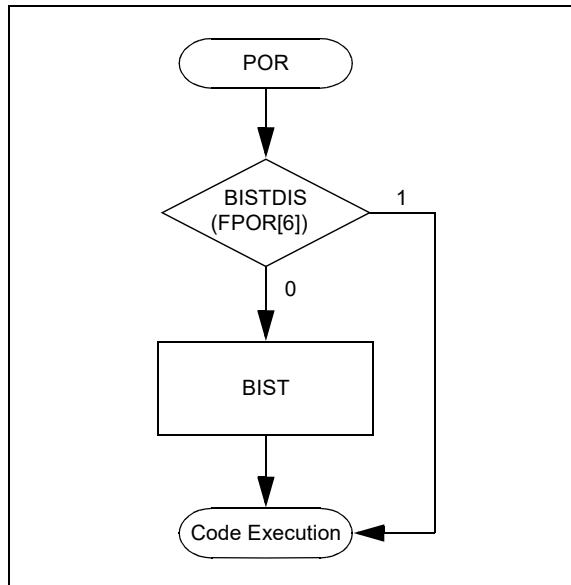
The dsPIC33CK256MP508 family features a data memory Built-In Self-Test (BIST) that has the option to be run at start-up or run time. The memory test checks that all memory locations are functional and provides a pass/fail status of the RAM that can be used by software to take action if needed. If a failure is reported, the specific location(s) are not identified. The BIST feature operates with a clock of FRC+PLL, with PLL settings forced by hardware to result in a 125 MHz clock rate, at both start-up and run time.

The MBISTCON register (Register 4-1) contains control and status bits for BIST operation. The MBISTDONE bit (MBISTCON[7]) indicates if a BIST was run since the last Reset and the MBISTSTAT bit (MBISTCON[4]) provides the pass/fail result.

### 4.3.1 BIST AT START-UP

The BIST can be configured to automatically run on a POR-type Reset, as shown in Figure 4-10. By default, when BISTDIS (FPOR[6]) = 1, the BIST is disabled and will not be part of device start-up. If the BISTDIS bit is cleared during device programming, the BIST will run after all Configuration registers have been loaded and before code execution begins.

FIGURE 4-10: BIST FLOWCHART



### 4.3.2 BIST AT RUN TIME

A BIST test can be requested to run on subsequent device Resets at any time.

A BIST will corrupt all of the RAM contents, including the Stack Pointer, and requires a subsequent Reset. The system should be prepared for a Reset before a BIST is performed. The BIST is invoked by setting the MBISTEN bit (MBISTCON[0]) and executing a Reset. The MBISTCON register is protected against accidental writes and requires an unlock sequence prior to writing. Only one bit can be set per unlock sequence. The procedure for a run-time BIST is as follows:

1. Execute the unlock sequence by consecutively writing 0x55 and 0xAA to the NVMKEY register.
2. Write 0x0001 to the MBISTCON SFR.
3. Execute a Software RESET command.
4. Verify a Software Reset has occurred by reading SWR (RCON[6]) (optional).
5. Verify that the MBISTDONE bit is set.
6. Take action depending on test result indicated by MBISTSTAT.

# dsPIC33CK256MP508 FAMILY

## 4.3.2.1 Fault Simulation

A mechanism is available to simulate a BIST failure to allow testing of Fault handling software. When the FLTINJ bit is set during a run-time BIST, the MBISTSTAT bit will be set regardless of the test result. The procedure for a BIST Fault simulation is as follows:

1. Execute the unlock sequence by consecutively writing 0x55 and 0xAA to the NVMKEY register.
2. Set the MBISTEN bit (MBISTCON[0]).
3. Execute 2nd unlock sequence by consecutively writing 0x55 and 0xAA to the NVMKEY register.
4. Set the FLTINJ bit (MBISTCON[8]).
5. Execute a software `RESET` command.
6. Verify the MBISTDONE, MBISTSTAT and FLTINJ bits are all set.

## REGISTER 4-1: MBISTCON: MBIST CONTROL REGISTER

U-0	U-0	U-0	U-0	U-0	U-0	U-0	R/W-0 <sup>(1)</sup>
—	—	—	—	—	—	—	FLTINJ
bit 15							bit 8

R/W/HS-0	U-0	U-0	R-0	U-0	U-0	U-0	R/W/HC-0
MBISTDONE <sup>(1)</sup>	—	—	MBISTSTAT	—	—	—	MBISTEN <sup>(2)</sup>
bit 7							bit 0

<b>Legend:</b>	HS = Hardware Settable bit	HC = Hardware Clearable bit
R = Readable bit	W = Writable bit	U = Unimplemented bit, read as '0'
-n = Value at POR	'1' = Bit is set	'0' = Bit is cleared      x = Bit is unknown

- bit 15-9      **Unimplemented:** Read as '0'
- bit 8      **FLTINJ:** MBIST Fault Inject Control bit<sup>(1)</sup>  
 1 = The MBIST test will complete and sets MBISTSTAT = 1, simulating an SRAM test failure  
 0 = The MBIST test will execute normally
- bit 7      **MBISTDONE:** MBIST Done Status bit<sup>(1)</sup>  
 1 = An MBIST operation has been executed  
 0 = No MBIST operation has occurred on the last Reset sequence
- bit 6-5      **Unimplemented:** Read as '0'
- bit 4      **MBISTSTAT:** MBIST Status bit  
 1 = The last MBIST failed  
 0 = The last MBIST passed; all memory may not have been tested
- bit 3-1      **Unimplemented:** Read as '0'
- bit 0      **MBISTEN:** MBIST Enable bit<sup>(2)</sup>  
 1 = MBIST test is armed; an MBIST test will execute at the next device Reset  
 0 = MBIST test is disarmed

- Note 1:** HW resets only on a true POR Reset.  
**Note 2:** This bit will self-clear when the MBIST test is complete.

# dsPIC33CK256MP508 FAMILY

## 4.4 Memory Resources

Many useful resources are provided on the main product page of the Microchip website for the devices listed in this data sheet. This product page contains the latest updates and additional information.

### 4.4.1 KEY RESOURCES

- “Enhanced CPU” (DS70005158) in the “dsPIC33/PIC24 Family Reference Manual”
- Code Samples
- Application Notes
- Software Libraries

- Webinars
- All Related “dsPIC33/PIC24 Family Reference Manual” Sections
- Development Tools

## 4.5 SFR Maps

The following tables show the dsPIC33CK256MP508 family SFR names, addresses and Reset values. These tables contain all registers applicable to the dsPIC33CK256MP508 family. Not all registers are present on all device variants. Refer to [Table 1](#) and [Table 2](#) for peripheral availability. [Table 8-1](#) details port availability for the different package options.

**TABLE 4-2: SFR BLOCK 000h**

Register	Address	All Resets	Register	Address	All Resets	Register	Address	All Resets
<b>Core</b>			XMODSRT	048	xxxxxxxxxxxxxxxxx0	<b>CRC</b>		
WREG0	000	0000000000000000	XMODEND	04A	xxxxxxxxxxxxxxxxx1	CRCCONL	0B0	--000000010000--
WREG1	002	0000000000000000	YMODSRT	04C	xxxxxxxxxxxxxxxxx0	CRCCONH	0B2	---00000---00000
WREG2	004	0000000000000000	YMODEND	04E	xxxxxxxxxxxxxxxxx1	CRCXORL	0B4	00000000000000--
WREG3	006	0000000000000000	XBREV	050	xxxxxxxxxxxxxxxxxx	CRCXORH	0B6	0000000000000000
WREG4	008	0000000000000000	DISICNT	052	-xxxxxxxxxxxxxxxx00	CRCDATL	0B8	0000000000000000
WREG5	00A	0000000000000000	TBLPAG	054	-----00000000	CRCDATH	0BA	0000000000000000
WREG6	00C	0000000000000000	YPAG	056	-----00000001	CRCWDATL	0BC	0000000000000000
WREG7	00E	0000000000000000	MSTRPR	058	-----00---0	CRCWDATH	0BE	0000000000000000
WREG8	010	0000000000000000	CTXTSTAT	05A	-----000-----000	<b>CLC</b>		
WREG9	012	0000000000000000	DMTCON	05C	-----	CLC1CONL	0C0	--0-00--000--000
WREG10	014	0000000000000000	DMTPRECLR	060	xxxxxxx-----	CLC1CONH	0C2	-----
WREG11	016	0000000000000000	DMTCLR	064	-----xxxxxxxx	CLC1SEL	0C4	0000-000-000-000
WREG12	018	0000000000000000	DMTSTAT	068	-----xxx-----x	CLC1GLSL	0C8	0000000000000000
WREG13	01A	0000000000000000	DMTCNTL	06C	xxxxxxxxxxxxxxxxxx	CLC1GLSH	0CA	0000000000000000
WREG14	01C	0000000000000000	DMTCNTH	06E	xxxxxxxxxxxxxxxxxx	CLC2CONL	0CC	--0-00--000--000
WREG15	01E	0001000000000000	DMTHOLDREG	070	xxxxxxxxxxxxxxxxxx	CLC2CONH	0CE	-----
SPLIM	020	xxxxxxxxxxxxxxxxxx	DMTPSCNTL	074	xxxxxxxxxxxxxxxxxx	CLC2SELL	0D0	0000-000-000-000
ACCAL	022	xxxxxxxxxxxxxxxxxx	DMTPSCNTH	076	xxxxxxxxxxxxxxxxxx	CLC2GLSL	0D4	0000000000000000
ACCAH	024	xxxxxxxxxxxxxxxxxx	DMTPSINTVL	078	xxxxxxxxxxxxxxxxxx	CLC2GLSH	0D6	0000000000000000
ACCAU	026	xxxxxxxxxxxxxxxxxx	DMTPSINTVH	07A	xxxxxxxxxxxxxxxxxx	CLC3CONL	0D8	--0-00--000--000
ACCBL	028	xxxxxxxxxxxxxxxxxx	<b>SENT</b>			CLC3CONH	0DA	-----
ACCBH	02A	xxxxxxxxxxxxxxxxxx	SENT1CON1	080	--0-000000-0-000	CLC3SELL	0DC	0000-000-000-000
ACCBU	02C	xxxxxxxxxxxxxxxxxx	SENT1CON2	084	0000000000000000	CLC3GLSL	0E0	0000000000000000
PCL	02E	0000000000000000	SENT1CON3	088	0000000000000000	CLC3GLSH	0E2	0000000000000000
PCH	030	-----00000000	SENT1STAT	08C	-----00000000	CLC4CONL	0E4	--0-00--000--000
DSRPAG	032	-----000000001	SENT1SYNC	090	0000000000000000	CLC4CONH	0E6	-----
DSWPAG	034	-----000000001	SENT1DATL	094	0000000000000000	CLC4SELL	0E8	0000-000-000-000
RCOUNT	036	xxxxxxxxxxxxxxxxxx	SENT1DATH	096	0000000000000000	CLC4GLSL	0EC	0000000000000000
DCOUNT	038	xxxxxxxxxxxxxxxxxx	SENT2CON1	098	--0-000000-0-000	CLC4GLSH	0EE	0000000000000000
DOSTARTL	03A	xxxxxxxxxxxxxxxxx0	SENT2CON2	09C	0000000000000000	<b>ECC</b>		
DOSTARTH	03C	-----xxxxxxxx	SENT2CON3	0A0	0000000000000000	ECCCONL	0F0	-----
DOENDL	03E	xxxxxxxxxxxxxxxxx0	SENT2STAT	0A4	-----00000000	ECCCONH	0F2	0000000000000000
DOENDH	040	-----xxxxxxxx	SENT2SYNC	0A8	0000000000000000	ECCADDRL	0F4	0000000000000000
SR	042	0000000000000000	SENT2DATL	0AC	0000000000000000	ECCADDRH	0F6	0000000000000000
CORCON	044	--xx000000100000	SENT2DATH	0AE	0000000000000000	ECCSTATL	0F8	0000000000000000
MODCON	046	0--0000000000000				ECCSTATH	0FA	-----0000000000

**Legend:** x = unknown or indeterminate value; “-” = unimplemented bits. Address values are in hexadecimal. Reset values are in binary.

# dsPIC33CK256MP508 FAMILY

**TABLE 4-3: SFR BLOCK 100h**

Register	Address	All Resets	Register	Address	All Resets	Register	Address	All Resets
<b>Timers</b>			INDX1HLD	16A	0000000000000000	INDX2HLD	19E	0000000000000000
T1CON	100	--0000000-00-00-	QE1GECL/ QE1ICL	16C	0000000000000000	QE1GECL/ QE1ICL	1A0	0000000000000000
TMR1	104	0000000000000000	QE1GECH/ QE1ICH	16E	0000000000000000	QE1GECH/ QE1ICH	1A2	0000000000000000
PR1	108	0000000000000000	QE1LECL	170	0000000000000000	QE1LECL	1A4	0000000000000000
<b>QE1</b>			QE1LECH	172	0000000000000000	QE1LECH	1A6	0000000000000000
QE1CON	140	--000000-0000000	QE2CON	174	--000000-0000000	<b>PMP</b>		
QE1IOC	144	000000000000xxxx	QE2IOC	178	000000000000xxxx	PMCON	1A8	--0000000000-00
QE1IOCH	146	-----0	QE2IOCH	17A	-----0	PMCONH	1AA	-----0-----0-
QE1STAT	148	--00000000000000	QE2STAT	17C	--00000000000000	PMMODE	1AC	0000000000000000
POS1CNTL	14C	0000000000000000	POS2CNTL	180	0000000000000000	PMADDR	1B0	0000000000000000
POS1CNTH	14E	0000000000000000	POS2CNTH	182	0000000000000000	PMDOUT1	1B4	0000000000000000
POS1HLD	152	0000000000000000	POS2HLD	186	0000000000000000	PMDOUT2	1B6	0000000000000000
VEL1CNT	154	0000000000000000	VEL2CNT	188	0000000000000000	PMDIN1	1B8	0000000000000000
VEL1CNTH	156	0000000000000000	VEL2CNTH	18A	0000000000000000	PMDIN2	1BA	0000000000000000
VEL1HLD	15A	0000000000000000	VEL2HLD	18E	0000000000000000	PMAEN	1BC	0000000000000000
INT1TMRL	15C	0000000000000000	INT2TMRL	190	0000000000000000	PMSTAT	1C0	00--000010--1111
INT1TMRH	15E	0000000000000000	INT2TMRH	192	0000000000000000	PMWADDR	1C4	0000000000000000
INT1HLDL	160	0000000000000000	INT2HLDL	194	0000000000000000	PMRADDR	1C8	0000000000000000
INT1HLDH	162	0000000000000000	INT2HLDH	196	0000000000000000	PMRDIN	1CC	0000000000000000
INDX1CNTL	164	0000000000000000	INDX2CNTL	198	0000000000000000			
INDX1CNTH	166	0000000000000000	INDX2CNTH	19A	0000000000000000			

**Legend:** x = unknown or indeterminate value; "-" = unimplemented bits. Address values are in hexadecimal. Reset values are in binary.

# dsPIC33CK256MP508 FAMILY

**TABLE 4-4: SFR BLOCK 200h**

Register	Address	All Resets	Register	Address	All Resets	Register	Address	All Resets
<b>I2C1 and I2C2</b>			U1SCCON	258	-----00000-	SPI1IMSKH	2C2	--000000-000000
I2C1CONL	200	--01000000000000	U1SCINT	25A	--00-000--00-000	SPI1URDTL	2C4	0000000000000000
I2C1CONH	202	-----00000000	U1INT	25C	-----00---0--	SPI1URDTH	2C6	0000000000000000
I2C1STAT	204	000--00000000000	U2MODE	260	--000-0000000000	SPI2CON1L	2C8	--00000000000000
I2C1ADD	208	-----0000000000	U2MODEH	262	00---0000000000	SPI2CON1H	2CA	0000000000000000
I2C1MSK	20C	-----0000000000	U2STA	264	0000000010000000	SPI2CON2L	2CC	-----00000
I2C1BRG	210	0000000000000000	U2STAH	266	0000-00000101110	SPI2CON2H	2CE	-----
I2C1TRN	214	-----11111111	U2BRG	268	0000000000000000	SPI2STATL	2D0	---00--0001-1-00
I2C1RCV	218	-----00000000	U2BRGH	26A	-----0000	SPI2STATH	2D2	--000000--000000
I2C2CONL	21C	--01000000000000	U2RXREG	26C	-----xxxxxxxx	SPI2BUFL	2D4	0000000000000000
I2C2CONH	21E	-----00000000	U2TXREG	270	-----xxxxxxxx	SPI2BUFH	2D6	0000000000000000
I2C2STAT	220	000--00000000000	U2P1	274	-----0000000000	SPI2BRGL	2D8	---xxxxxxxxxxxxxxx
I2C2ADD	224	-----0000000000	U2P2	276	-----0000000000	SPI2BRGH	2DA	-----
I2C2MSK	228	-----0000000000	U2P3	278	0000000000000000	SPI2IMSKL	2DC	---00--0000-0-00
I2C2BRG	22C	0000000000000000	U2P3H	27A	-----00000000	SPI2IMSKH	2DE	--0000000-000000
I2C2TRN	230	-----11111111	U2TXCHK	27C	-----00000000	SPI2URDTL	2E0	0000000000000000
I2C2RCV	234	-----00000000	U2RXCHK	27E	-----00000000	SPI2URDTH	2E2	0000000000000000
<b>UART1 and UART2</b>			U2SCCON	280	-----00000-	SPI3CON1L	2E4	--00000000000000
U1MODE	238	--000-0000000000	U2SCINT	282	--00-000--00-000	SPI3CON1H	2E6	0000000000000000
U1MODEH	23A	00---0000000000	U2INT	284	-----00---0--	SPI3CON2L	2E8	-----00000
U1STA	23C	0000000010000000	<b>SPI</b>			SPI3CON2H	2EA	-----
U1STAH	23E	0000-00000101110	SPI1CON1L	2AC	--00000000000000	SPI3STATL	2EC	---00--0001-1-00
U1BRG	240	0000000000000000	SPI1CON1H	2AE	0000000000000000	SPI3STATH	2EE	--000000--000000
U1BRGH	242	-----0000	SPI1CON2L	2B0	-----00000	SPI3BUFL	2F0	0000000000000000
U1RXREG	244	-----xxxxxxxx	SPI1CON2H	2B2	-----	SPI3BUFH	2F2	0000000000000000
U1TXREG	248	-----xxxxxxxx	SPI1STATL	2B4	---00--0001-1-00	SPI3BRGL	2F4	---xxxxxxxxxxxxxxx
U1P1	24C	-----0000000000	SPI1STATH	2B6	--000000--000000	SPI3BRGH	2F6	-----
U1P2	24E	-----0000000000	SPI1BUFL	2B8	0000000000000000	SPI3IMSKL	2F8	---00--0000-0-00
U1P3	250	0000000000000000	SPI1BUFH	2BA	0000000000000000	SPI3IMSKH	2FA	--0000000-000000
U1P3H	252	-----00000000	SPI1BRGL	2BC	---xxxxxxxxxxxxxxx	SPI3URDTL	2FC	0000000000000000
U1TXCHK	254	-----00000000	SPI1BRGH	2BE	-----	SPI3URDTH	2F3	0000000000000000
U1RXCHK	256	-----00000000	SPI1IMSKL	2C0	---00--0000-0-00			

**Legend:** x = unknown or indeterminate value; "-" = unimplemented bits. Address values are in hexadecimal. Reset values are in binary.



# dsPIC33CK256MP508 FAMILY

**TABLE 4-5: SFR BLOCK 300h**

Register	Address	All Resets	Register	Address	All Resets	Register	Address	All Resets
<b>High-Speed PWM</b>			PG1TRIGA	354	0000000000000000	PG3CLPCIH	3AA	0000-000000000000
PCLKCON	300	00-----0--0--00	PG1TRIGB	356	0000000000000000	PG3FFPCIL	3AC	0000000000000000
FSCL	302	0000000000000000	PG1TRIGC	358	0000000000000000	PG3FFPCIH	3AE	0000-000000000000
FSMINPER	304	0000000000000000	PG1DTL	35A	--0000000000000000	PG3SPCIL	3B0	0000000000000000
MPHASE	306	0000000000000000	PG1DTH	35C	--0000000000000000	PG3SPCIH	3B2	0000-000000000000
MDC	308	0000000000000000	PG1CAP	35E	0000000000000000	PG3LEBL	3B4	0000000000000000
MPER	30A	0000000000000000	PG2CONL	360	-----0000--000000	PG3LEBH	3B6	-----000----00000
LFSR	30C	0000000000000000	PG2CONH	362	000-000000--000000	PG3PHASE	3B8	0000000000000000
CMBTRIGL	30E	-----0000000000	PG2STAT	364	0000000000000000	PG3DC	3BA	0000000000000000
CMBTRIGH	310	-----0000000000	PG2IOCONL	366	0000000000000000	PG3DCA	3BC	-----0000000000
LOGCONA	312	000000000000-000	PG2IOCONH	368	0000---0--00000000	PG3PER	3BE	0000000000000000
LOGCONB	314	000000000000-000	PG2EVTL	36A	00000000---00000000	PG3TRIGA	3C0	0000000000000000
LOGCONC	316	000000000000-000	PG2EVTH	36C	0000--000000000000	PG3TRIGB	3C2	0000000000000000
LOGCOND	318	000000000000-000	PG2FPCIL	36E	0000000000000000	PG3TRIGC	3C4	0000000000000000
LOGCONE	31A	000000000000-000	PG2FPCIH	370	0000-000000000000	PG3DTL	3C6	--0000000000000000
LOGCONF	31C	000000000000-000	PG2CLPCIL	372	0000000000000000	PG3DTH	3C8	--0000000000000000
PWMEVTA	31E	0000----0000-000	PG2CLPCIH	374	0000-000000000000	PG3CAP	3CA	0000000000000000
PWMEVTB	320	0000----0000-000	PG2FFPCIL	376	0000000000000000	PG4CONL	3CC	-----0000--000000
PWMEVTC	322	0000----0000-000	PG2FFPCIH	378	0000-000000000000	PG4CONH	3CE	000-000000--000000
PWMEVTD	324	0000----0000-000	PG2SPCIL	37A	0000000000000000	PG4STAT	3D0	0000000000000000
PWMEVTE	326	0000----0000-000	PG2SPCIH	37C	0000-000000000000	PG4IOCONL	3D2	0000000000000000
PWMEVTF	328	0000----0000-000	PG2LEBL	37E	0000000000000000	PG4IOCONH	3D4	0000---0--00000000
PG1CONL	32A	-----0000--000000	PG2LEBH	380	-----000----00000	PG4EVTL	3D6	00000000---000000
PG1CONH	32C	000-000000--000000	PG2PHASE	382	0000000000000000	PG4EVTH	3D8	0000--000000000000
PG1STAT	32E	0000000000000000	PG2DC	384	0000000000000000	PG4FPCIL	3DA	0000000000000000
PG1IOCONL	330	0000000000000000	PG2DCA	386	-----0000000000	PG4FPCIH	3DC	0000-000000000000
PG1IOCONH	332	0000---0--00000000	PG2PER	388	0000000000000000	PG4CLPCIL	3DE	0000000000000000
PG1EVTL	334	00000000---00000000	PG2TRIGA	38A	0000000000000000	PG4CLPCIH	3E0	0000-000000000000
PG1EVTH	336	0000--000000000000	PG2TRIGB	38C	0000000000000000	PG4FFPCIL	3E2	0000000000000000
PG1FPCIL	338	0000000000000000	PG2TRIGC	38E	0000000000000000	PG4FFPCIH	3E4	0000-000000000000
PG1FPCIH	33A	0000-000000000000	PG2DTL	390	--0000000000000000	PG4SPCIL	3E6	0000000000000000
PG1CLPCIL	33C	0000000000000000	PG2DTH	392	--0000000000000000	PG4SPCIH	3E8	0000-000000000000
PG1CLPCIH	33E	0000-000000000000	PG2CAP	394	0000000000000000	PG4LEBL	3EA	0000000000000000
PG1FFPCIL	340	0000000000000000	PG3CONL	396	-----0000--000000	PG4LEBH	3EC	-----000----00000
PG1FFPCIH	342	0000-000000000000	PG3CONH	398	000-000000--000000	PG4PHASE	3EE	0000000000000000
PG1SPCIL	344	0000000000000000	PG3STAT	39A	0000000000000000	PG4DC	3F0	0000000000000000
PG1SPCIH	346	0000-000000000000	PG3IOCONL	39C	0000000000000000	PG4DCA	3F2	-----0000000000
PG1LEBL	348	0000000000000000	PG3IOCONH	39E	0000---0--00000000	PG4PER	3F4	0000000000000000
PG1LEBH	34A	-----000----00000	PG3EVTL	3A0	00000000---00000000	PG4TRIGA	3F6	0000000000000000
PG1PHASE	34C	0000000000000000	PG3EVTH	3A2	0000--000000000000	PG4TRIGB	3F8	0000000000000000
PG1DC	34E	0000000000000000	PG3FPCIL	3A4	0000000000000000	PG4TRIGC	3FA	0000000000000000
PG1DCA	350	-----0000000000	PG3FPCIH	3A6	0000-000000000000	PG4DTL	3FC	--0000000000000000
PG1PER	352	0000000000000000	PG3CLPCIL	3A8	0000000000000000	PG4DTH	3FE	--0000000000000000

**Legend:** x = unknown or indeterminate value; "-" = unimplemented bits. Address values are in hexadecimal. Reset values are in binary.

# dsPIC33CK256MP508 FAMILY

**TABLE 4-6: SFR BLOCK 400h**

Register	Address	All Resets	Register	Address	All Resets	Register	Address	All Resets
<b>High-Speed PWM (Continued)</b>			PG6FPCIH	448	0000-000000000000	PG7DC	492	0000000000000000
PG4CAP	400	0000000000000000	PG6CLPCIL	44A	0000000000000000	PG7DCA	494	-----00000000
PG5CONL	402	-----0000--000000	PG6CLPCIH	44C	0000-000000000000	PG7PER	496	0000000000000000
PG5CONH	404	000-000000--0000	PG6FFPCIL	44E	0000000000000000	PG7TRIGA	498	0000000000000000
PG5STAT	406	0000000000000000	PG6FFPCIH	450	0000-000000000000	PG7TRIGB	49A	0000000000000000
PG5IOCONL	408	0000000000000000	PG6SPCIL	452	0000000000000000	PG7TRIGC	49C	0000000000000000
PG5IOCONH	40A	0000---0---000000	PG6SPCIH	454	0000-000000000000	PG7DTL	49E	--00000000000000
PG5EVTL	40C	00000000---00000	PG6LEBL	456	0000000000000000	PG7DTH	4A0	--00000000000000
PG5EVTH	40E	0000--0000000000	PG6LEBH	458	-----000---0000	PG7CAP	4A2	0000000000000000
PG5FPCIL	410	0000000000000000	PG6PHASE	45A	0000000000000000	PG8CONL	4A4	-----0000--0000
PG5FPCIH	412	0000-000000000000	PG6DC	45C	0000000000000000	PG8CONH	4A6	000-000000--0000
PG5CLPCIL	414	0000000000000000	PG6DCA	45E	-----00000000	PG8STAT	4A8	0000000000000000
PG5CLPCIH	416	0000-000000000000	PG6PER	460	0000000000000000	PG8IOCONL	4AA	0000000000000000
PG5FFPCIL	418	0000000000000000	PG6TRIGA	462	0000000000000000	PG8IOCONH	4AC	0000---0--000000
PG5FFPCIH	41A	0000-000000000000	PG6TRIGB	464	0000000000000000	PG8EVTL	4AE	00000000---00000
PG5SPCIL	41C	0000000000000000	PG6TRIGC	466	0000000000000000	PG8EVTH	4B0	0000--0000000000
PG5SPCIH	41E	0000-000000000000	PG6DTL	468	--00000000000000	PG8FPCIL	4B2	0000000000000000
PG5LEBL	420	0000000000000000	PG6DTH	46A	--00000000000000	PG8FPCIH	4B4	0000-000000000000
PG5LEBH	422	-----000---0000	PG6CAP	46C	0000000000000000	PG8CLPCIL	4B6	0000000000000000
PG5PHASE	424	0000000000000000	PG7CONL	46E	-----0000--0000	PG8CLPCIH	4B8	0000-000000000000
PG5DC	426	0000000000000000	PG7CONH	470	000-000000--0000	PG8FFPCIL	4BA	0000000000000000
PG5DCA	428	-----00000000	PG7STAT	472	0000000000000000	PG8FFPCIH	4BC	0000-000000000000
PG5PER	42A	0000000000000000	PG7IOCONL	474	0000000000000000	PG8SPCIL	4BE	0000000000000000
PG5TRIGA	42C	0000000000000000	PG7IOCONH	476	0000---0--000000	PG8SPCIH	4C0	0000-000000000000
PG5TRIGB	42E	0000000000000000	PG7EVTL	478	00000000---00000	PG8LEBL	4C2	0000000000000000
PG5TRIGC	430	0000000000000000	PG7EVTH	47A	0000--0000000000	PG8LEBH	4C4	-----000---0000
PG5DTL	432	--00000000000000	PG7FPCIL	47C	0000000000000000	PG8PHASE	4C6	0000000000000000
PG5DTH	434	--00000000000000	PG7FPCIH	47E	0000-000000000000	PG8DC	4C8	0000000000000000
PG5CAP	436	0000000000000000	PG7CLPCIL	480	0000000000000000	PG8DCA	4CA	-----00000000
PG6CONL	438	-----0000--0000	PG7CLPCIH	482	0000-000000000000	PG8PER	4CC	0000000000000000
PG6CONH	43A	000-000000--0000	PG7FFPCIL	484	0000000000000000	PG8TRIGA	4CE	0000000000000000
PG6STAT	43C	0000000000000000	PG7FFPCIH	486	0000-000000000000	PG8TRIGB	4D0	0000000000000000
PG6IOCONL	43E	0000000000000000	PG7SPCIL	488	0000000000000000	PG8TRIGC	4D2	0000000000000000
PG6IOCONH	440	0000---0---000000	PG7SPCIH	48A	0000-000000000000	PG8DTL	4D4	--00000000000000
PG6EVTL	442	00000000---00000	PG7LEBL	48C	0000000000000000	PG8DTH	4D6	--00000000000000
PG6EVTH	444	0000--0000000000	PG7LEBH	48E	-----000---0000	PG8CAP	4D8	0000000000000000
PG6FPCIL	446	0000000000000000	PG7PHASE	490	0000000000000000			

**Legend:** x = unknown or indeterminate value; "-" = unimplemented bits. Address values are in hexadecimal. Reset values are in binary.

# dsPIC33CK256MP508 FAMILY

**TABLE 4-7: SFR BLOCK 500h**

Register	Address	All Resets	Register	Address	All Resets	Register	Address	All Resets
<b>CAN</b>			C1TSCONL	5D4	-----0000000000	C1RXOVIFH	5EA	0000000000000000
C1CONL	5C0	--00011101100000	C1TSCONH	5D6	-----000	C1TXATIFL	5EC	0000000000000000
C1CONH	5C2	0000010010011000	C1VECL	5D8	---00000-1000000	C1TXATIFH	5EE	0000000000000000
C1NBTCFGL	5C4	00001111-0001111	C1VECH	5DA	11000000-1000000	C1TXREQL	5F0	0000000000000000
C1NBTCFGH	5C6	0000000000111110	C1INTL	5DC	000000-----00000	C1TXREQH	5F2	0000000000000000
C1DBTCFGL	5C8	----0011----0011	C1INTH	5DE	000000-----00000	C1TRECL	5F4	0000000000000000
C1DBTCFGH	5CA	00000000---01110	C1RXIFL	5E0	0000000000000000	C1TRECH	5F6	-----100000
C1TDCL	5CC	00010000--000000	C1RXIFH	5E2	0000000000000000	C1BDIAG0L	5F8	0000000000000000
C1TDCH	5CE	-----00-----10	C1TXIFL	5E4	000000000000000-	C1BDIAG0H	5FA	0000000000000000
C1TBCL	5D0	0000000000000000	C1TXIFH	5E6	0000000000000000	C1BDIAG1L	5FC	0000000000000000
C1TBCH	5D2	0000000000000000	C1RXOVIFL	5E8	000000000000000-	C1BDIAG1H	5FE	00000-000-000000

**Legend:** x = unknown or indeterminate value; "-" = unimplemented bits. Address values are in hexadecimal. Reset values are in binary.

# dsPIC33CK256MP508 FAMILY

**TABLE 4-8: SFR BLOCK 600h**

Register	Address	All Resets	Register	Address	All Resets	Register	Address	All Resets
<b>CAN (Continued)</b>			C1FIFOSTA6	65C	---00000000000000	C1FLTOBJ6L	6B0	0000000000000000
C1TEFCONL	600	-----1-0--0-0000	C1FIFOUA6L	660	xxxxxxxxxxxxxxxxxxxx	C1FLTOBJ6H	6B2	0000000000000000
C1TEFCONH	602	---00000-----	C1FIFOUA6H	662	xxxxxxxxxxxxxxxxxxxx	C1MASK6L	6B4	0000000000000000
C1TEFSTA	604	-----0000	C1FIFOCON7L	664	-----100x00000000	C1MASK6H	6B6	0000000000000000
C1TEFUAL	608	xxxxxxxxxxxxxxxxxxxx	C1FIFOCON7H	666	00000000-11000000	C1FLTOBJ7L	7B8	0000000000000000
C1TEFUAH	60A	xxxxxxxxxxxxxxxxxxxx	C1FIFOSTA7	668	---00000000000000	C1FLTOBJ7H	6BA	0000000000000000
C1FIFOBAL	60C	0000000000000000	C1FIFOUA7L	66C	xxxxxxxxxxxxxxxxxxxx	C1MASK7L	6BC	0000000000000000
C1FIFOBAL	60E	0000000000000000	C1FIFOUA7H	66E	xxxxxxxxxxxxxxxxxxxx	C1MASK7H	6BE	0000000000000000
C1TXQCONL	610	-----100x00000000	C1FLTCON0L	670	---000000--000000	C1FLTOBJ8L	6C0	0000000000000000
C1TXQCONH	612	00000000-11000000	C1FLTCON0H	672	---000000--000000	C1FLTOBJ8H	6C2	0000000000000000
C1TXQSTA	614	---000000000-0-0	C1FLTCON1L	674	---000000--000000	C1MASK8L	6C4	0000000000000000
C1TXQUAL	618	xxxxxxxxxxxxxxxxxxxx	C1FLTCON1H	676	---000000--000000	C1MASK8H	6C6	0000000000000000
C1TXQUAH	61A	xxxxxxxxxxxxxxxxxxxx	C1FLTCON2L	678	---000000--000000	C1FLTOBJ9L	6C8	0000000000000000
C1FIFOCON1L	61C	-----100x00000000	C1FLTCON2H	67A	---000000--000000	C1FLTOBJ9H	6CA	0000000000000000
C1FIFOCON1H	61E	00000000-11000000	C1FLTCON3L	67C	---000000--000000	C1MASK9L	6CC	0000000000000000
C1FIFOSTA1	620	---00000000000000	C1FLTCON3H	67E	---000000--000000	C1MASK9H	6CE	0000000000000000
C1FIFOUA1L	624	xxxxxxxxxxxxxxxxxxxx	C1FLTOBJ0L	680	0000000000000000	C1FLTOBJ10L	6D0	0000000000000000
C1FIFOUA1H	626	xxxxxxxxxxxxxxxxxxxx	C1FLTOBJ0H	682	0000000000000000	C1FLTOBJ10H	6D2	0000000000000000
C1FIFOCON2L	628	-----100x00000000	C1MASK0L	684	0000000000000000	C1MASK10L	6D4	0000000000000000
C1FIFOCON2H	62A	00000000-11000000	C1MASK0H	686	0000000000000000	C1MASK10H	6D6	0000000000000000
C1FIFOSTA2	62C	---00000000000000	C1FLTOBJ1L	688	0000000000000000	C1FLTOBJ11L	6D8	0000000000000000
C1FIFOUA2L	630	xxxxxxxxxxxxxxxxxxxx	C1FLTOBJ1H	68A	0000000000000000	C1FLTOBJ11H	6DA	0000000000000000
C1FIFOUA2H	632	xxxxxxxxxxxxxxxxxxxx	C1MASK1L	68C	0000000000000000	C1MASK11L	6DC	0000000000000000
C1FIFOCON3L	634	-----100x00000000	C1MASK1H	68E	0000000000000000	C1MASK11H	6DE	0000000000000000
C1FIFOCON3H	636	00000000-11000000	C1FLTOBJ2L	690	0000000000000000	C1FLTOBJ12L	6E0	0000000000000000
C1FIFOSTA3	638	---00000000000000	C1FLTOBJ2H	692	0000000000000000	C1FLTOBJ12H	6E2	0000000000000000
C1FIFOUA3L	63C	xxxxxxxxxxxxxxxxxxxx	C1MASK2L	694	0000000000000000	C1MASK12L	6E4	0000000000000000
C1FIFOUA3H	63E	xxxxxxxxxxxxxxxxxxxx	C1MASK2H	696	0000000000000000	C1MASK12H	6E6	0000000000000000
C1FIFOCON4L	640	-----100x00000000	C1FLTOBJ3L	698	0000000000000000	C1FLTOBJ13L	6E8	0000000000000000
C1FIFOCON4H	642	00000000-11000000	C1FLTOBJ3H	69A	0000000000000000	C1FLTOBJ13H	6EA	0000000000000000
C1FIFOSTA4	644	---00000000000000	C1MASK3L	69C	0000000000000000	C1MASK13L	6EC	0000000000000000
C1FIFOUA4L	648	xxxxxxxxxxxxxxxxxxxx	C1MASK3H	69C	0000000000000000	C1MASK13H	6EE	0000000000000000
C1FIFOUA4H	64A	xxxxxxxxxxxxxxxxxxxx	C1FLTOBJ4L	6A0	0000000000000000	C1FLTOBJ14L	6F0	0000000000000000
C1FIFOCON5L	64C	-----100x00000000	C1FLTOBJ4H	6A2	0000000000000000	C1FLTOBJ14H	6F2	0000000000000000
C1FIFOCON5H	64E	00000000-11000000	C1MASK4L	6A4	0000000000000000	C1MASK14L	6F4	0000000000000000
C1FIFOSTA5	650	---00000000000000	C1MASK4H	6A6	0000000000000000	C1MASK14H	6F6	0000000000000000
C1FIFOUA5L	654	xxxxxxxxxxxxxxxxxxxx	C1FLTOBJ5L	6A8	0000000000000000	C1FLTOBJ15L	6F8	0000000000000000
C1FIFOUA5H	656	xxxxxxxxxxxxxxxxxxxx	C1FLTOBJ5H	6AA	0000000000000000	C1FLTOBJ15H	6FA	0000000000000000
C1FIFOCON6L	658	-----100x00000000	C1MASK5L	6AC	0000000000000000	C1MASK15L	6FC	0000000000000000
C1FIFOCON6H	65A	00000000-11000000	C1MASK5H	6AE	0000000000000000	C1MASK15H	6FE	0000000000000000

**Legend:** x = unknown or indeterminate value; "-" = unimplemented bits. Address values are in hexadecimal. Reset values are in binary.

# dsPIC33CK256MP508 FAMILY

**TABLE 4-9: SFR BLOCK 800h**

Register	Address	All Resets	Register	Address	All Resets	Register	Address	All Resets
<b>Interrupts</b>			IPC3	846	-100-100-100-100	IPC35	886	-100-100-----
IFS0	800	0000000000-000000	IPC4	848	-100-100-100-100	IPC36	888	-----100
IFS1	802	0000000000-000000	IPC5	84A	-100-----100-100	IPC37	88A	-----100-100----
IFS2	804	000000-00-0000----	IPC6	84C	-100-100-100-100	IPC38	88C	-----100-100
IFS3	806	00000000-0-000000	IPC7	84E	-100-100-100-100	IPC40	890	-----100-100
IFS4	808	00000000000000-00	IPC8	850	-100-100-----	IPC42	894	-100-100-100-100
IFS5	80A	000000000000000-	IPC9	852	-----100-100-100	IPC43	896	-100-100-100-100
IFS6	80C	0000000000000000	IPC10	854	-100-----100-100	IPC44	898	-100-100-100-100
IFS7	80E	0000000000000000	IPC11	856	-100-100-100-100	IPC45	89A	-----100-100-100
IFS8	810	00-----0	IPC12	858	-100-100-100-100	IPC47	89E	-100-100-100----
IFS9	812	-----00-00----	IPC13	85A	-----100-----100	IPC48	8A0	-100-100-100-100
IFS10	814	00000000-----00	IPC14	85C	-100-100-100-100	INTCON1	8C0	0000000000-0000-
IFS11	816	000-----0000000	IPC15	85E	-100-100-100----	INTCON2	8C2	100----0----0000
IFS12	818	-----0000	IPC16	860	-100-----100-100	INTCON3	8C4	-----00---0---0
IEC0	820	0000000000-000000	IPC17	862	-100-100-100-100	INTCON4	8C6	-----00000000
IEC1	822	0000000000-000000	IPC18	864	-100-100-100-100	INTTREG	8C8	000-0000-0000000
IEC2	824	000000-00-0000----	IPC19	866	-100-100-100-100	<b>Flash</b>		
IEC3	826	00000000-0-000000	IPC20	868	-100-100-100----	NVMCON	8D0	00000000----0000
IEC4	828	00000000000000-00	IPC21	86A	-100-100-100-100	NVMADR	8D2	0000000000000000
IEC5	82A	000000000000000-	IPC22	86C	-100-100-100-100	NVMADRU	8D4	-----00000000
IEC6	82C	0000000000000000	IPC23	86E	-100-100-100-100	NVMKEY	8D6	-----00000000
IEC7	82E	0000000000000000	IPC24	870	-100-100-100-100	NVMSRCADRL	8D8	0000000000000000
IEC8	830	0-----0	IPC25	872	-100-100-100-100	NVMSRCADRH	8DA	-----00000000
IEC9	832	-----00-00----	IPC26	874	-100-100-100-100	<b>CBG</b>		
IEC10	834	00000000-----00	IPC27	876	-100-100-100-100	AMPCON1L	8DC	-----000
IEC11	836	000-----0000000	IPC28	878	-100-100-100-100	AMPCON1H	8DE	-----000
IEC12	838	-----0000	IPC29	87A	-100-100-100-100	BIASCON	8F0	-----0000
IPC0	840	-100-100-100-100	IPC30	87C	-100-100-100-100	IBIASCON0L	8F4	--000000--000000
IPC1	842	-100-100-----100	IPC31	87E	-100-100-100-100	IBIASCON0H	8F6	--000000--000000
IPC2	844	-100-100-100-100	IPC32	880	-----100			

**Legend:** x = unknown or indeterminate value; "-" = unimplemented bits. Address values are in hexadecimal. Reset values are in binary.

# dsPIC33CK256MP508 FAMILY

**TABLE 4-10: SFR BLOCK 900h**

Register	Address	All Resets	Register	Address	All Resets	Register	Address	All Resets
<b>PTG</b>			CCP1CON2L	954	00-0----00000000	CCP3TMRH	9AA	0000000000000000
PTGCST	900	--00-00000x---00	CCP1CON2H	956	-----100-00000	CCP3PRL	9AC	1111111111111111
PTGCON	902	000000000000-000	CCP1CON3H	95A	0000-----0-00--	CCP3PRH	9AE	1111111111111111
PTGBTE	904	xxxxxxxxxxxxxxxx	CCP1STATL	95C	-----0--00xx0000	CCP3RAL	9B0	0000000000000000
PTGBTEH	906	0000000000000000	CCP1TMRL	960	0000000000000000	CCP3RBL	9B4	0000000000000000
PTGHOLD	908	0000000000000000	CCP1TMRH	962	0000000000000000	CCP3BUFL	9B8	0000000000000000
PTGTOLIM	90C	0000000000000000	CCP1PRL	964	1111111111111111	CCP3BUFH	9BA	0000000000000000
PTGT1LIM	910	0000000000000000	CCP1PRH	966	1111111111111111	CCP4CON1L	9BC	--00000000000000
PTGSDLIM	914	0000000000000000	CCP1RAL	968	0000000000000000	CCP4CON1H	9BE	00--000000000000
PTGCOLIM	918	0000000000000000	CCP1RBL	96C	0000000000000000	CCP4CON2L	9C0	00-0----00000000
PTGC1LIM	91C	0000000000000000	CCP1BUFL	970	0000000000000000	CCP4CON2H	9C2	-----100-00000
PTGADJ	920	0000000000000000	CCP1BUFH	972	0000000000000000	CCP4CON3H	9C6	0000-----0-00--
PTGL0	924	0000000000000000	CCP2CON1L	974	--00000000000000	CCP4STATL	9C8	-----0--00xx0000
PTGQPTR	928	-----00000	CCP2CON1H	976	00--000000000000	CCP4TMRL	9CC	0000000000000000
PTGQUE0	930	xxxxxxxxxxxxxxxx	CCP2CON2L	978	00-0----00000000	CCP4TMRH	9CE	0000000000000000
PTGQUE1	932	xxxxxxxxxxxxxxxx	CCP2CON2H	97A	0-----100-00000	CCP4PRL	9D0	1111111111111111
PTGQUE2	934	xxxxxxxxxxxxxxxx	CCP2CON3H	97E	0000-----0-00--	CCP4PRH	9D2	1111111111111111
PTGQUE3	936	xxxxxxxxxxxxxxxx	CCP2STATL	980	-----0--00xx0000	CCP4RAL	9D4	0000000000000000
PTGQUE4	938	xxxxxxxxxxxxxxxx	CCP2TMRL	984	0000000000000000	CCP4RBL	9D8	0000000000000000
PTGQUE5	93A	xxxxxxxxxxxxxxxx	CCP2TMRH	986	0000000000000000	CCP4BUFL	9DC	0000000000000000
PTGQUE6	93C	xxxxxxxxxxxxxxxx	CCP2PRL	988	1111111111111111	CCP4BUFH	9DE	0000000000000000
PTGQUE7	93E	xxxxxxxxxxxxxxxx	CCP2PRH	98A	1111111111111111	CCP5CON1L	9E0	--00000000000000
PTGQUE8	940	xxxxxxxxxxxxxxxx	CCP2RAL	98C	0000000000000000	CCP5CON1H	9E2	00--000000000000
PTGQUE9	942	xxxxxxxxxxxxxxxx	CCP2RBL	990	0000000000000000	CCP5CON2L	9E4	00-0----00000000
PTGQUE10	944	xxxxxxxxxxxxxxxx	CCP2BUFL	994	0000000000000000	CCP5CON2H	9E6	-----100-00000
PTGQUE11	946	xxxxxxxxxxxxxxxx	CCP2BUFH	996	0000000000000000	CCP5CON3H	9EA	0000-----0-00--
PTGQUE12	948	xxxxxxxxxxxxxxxx	CCP3CON1L	998	--00000000000000	CCP5STATL	9EC	-----0--00xx0000
PTGQUE13	94A	xxxxxxxxxxxxxxxx	CCP3CON1H	99A	00--000000000000	CCP5TMRL	9F0	0000000000000000
PTGQUE14	94C	xxxxxxxxxxxxxxxx	CCP3CON2L	99C	00-0----00000000	CCP5TMRH	9F2	0000000000000000
PTGQUE15	94E	xxxxxxxxxxxxxxxx	CCP3CON2H	99E	-----100-00000	CCP5PRL	9F4	1111111111111111
<b>CCP</b>			CCP3CON3H	9A2	0000-----0-00--	CCP5PRH	9F6	1111111111111111
CCP1CON1L	950	--00000000000000	CCP3STATL	9A4	-----0--00xx0000	CCP5RAL	9F8	0000000000000000
CCP1CON1H	952	00--000000000000	CCP3TMRL	9A8	0000000000000000	CCP5RBL	9FC	0000000000000000
CCP1CON2L	954	00-0----00000000						

**Legend:** x = unknown or indeterminate value; "-" = unimplemented bits. Address values are in hexadecimal. Reset values are in binary.

# dsPIC33CK256MP508 FAMILY

**TABLE 4-11: SFR BLOCK A00h**

Register	Address	All Resets	Register	Address	All Resets	Register	Address	All Resets
<b>CCP (Continued)</b>			CCP7BUFL	A48	0000000000000000	CCP9BUFL	A90	0000000000000000
CCP5BUFL	A00	0000000000000000	CCP7BUFH	A4A	0000000000000000	CCP9BUFH	A92	0000000000000000
CCP5BUFH	A02	0000000000000000	CCP8CON1L	A4C	--00000000000000	<b>DMA</b>		
CCP6CON1L	A04	--00000000000000	CCP8CON1H	A4E	00--000000000000	DMACON	ABC	--0-----0
CCP6CON1H	A06	00--000000000000	CCP8CON2L	A50	00-0----00000000	DMABUF	ABE	0000000000000000
CCP6CON2L	A08	00-0----00000000	CCP8CON2H	A52	0-----100-00000	DMAL	AC0	0000000000000000
CCP6CON2H	A0A	-----100-00000	CCP8CON3H	A56	0000-----0-00--	DMAH	AC2	0000000000000000
CCP6CON3H	A0E	0000-----0-00--	CCP8STATL	A58	-----0--00xx0000	DMACH0	AC4	-----0000000000
CCP6STATL	A10	-----0--00xx0000	CCP8TMRL	A5C	0000000000000000	DMAMNT0	AC6	--0000000000--0
CCP6TMRL	A14	0000000000000000	CCP8TMRH	A5E	0000000000000000	DMASRC0	AC8	0000000000000000
CCP6TMRH	A16	0000000000000000	CCP8PRL	A60	1111111111111111	DMADST0	ACA	0000000000000000
CCP6PRL	A18	1111111111111111	CCP8PRH	A62	1111111111111111	DMACNT0	ACC	0000000000000001
CCP6PRH	A1A	1111111111111111	CCP8RAL	A64	0000000000000000	DMACH1	ACE	-----0000000000
CCP6RAL	A1C	0000000000000000	CCP8RBL	A68	0000000000000000	DMAMNT1	AD0	--0000000000--0
CCP6RBL	A20	0000000000000000	CCP8BUFL	A6C	0000000000000000	DMASRC1	AD2	0000000000000000
CCP6BUFL	A24	0000000000000000	CCP8BUFH	A6E	0000000000000000	DMADST1	AD4	0000000000000000
CCP6BUFH	A26	0000000000000000	CCP9CON1L	A70	--00000000000000	DMACNT1	AD6	0000000000000001
CCP7CON1L	A28	--00000000000000	CCP9CON1H	A72	00--000000000000	DMACH2	AD8	-----0000000000
CCP7CON1H	A2A	00--000000000000	CCP9CON2L	A74	00-0----00000000	DMAMNT2	ADA	--0000000000--0
CCP7CON2L	A2C	00-0----00000000	CCP9CON2H	A76	--00000100-00000	DMASRC2	ADC	0000000000000000
CCP7CON2H	A2E	-----100-00000	CCP9CON3L	A78	-----00000000	DMADST2	ADE	0000000000000000
CCP7CON3H	A32	0000-----0-00--	CCP9CON3H	A7A	0000-000--000000	DMACNT2	AE0	0000000000000001
CCP7STATL	A34	-----0--00xx0000	CCP9STATL	A7C	-----0--00xx0000	DMACH3	AE2	-----0000000000
CCP7TMRL	A38	0000000000000000	CCP9TMRL	A80	0000000000000000	DMAMNT3	AE4	--0000000000--0
CCP7TMRH	A3A	0000000000000000	CCP9TMRH	A82	0000000000000000	DMASRC3	AE6	0000000000000000
CCP7PRL	A3C	1111111111111111	CCP9PRL	A84	1111111111111111	DMADST3	AE8	0000000000000000
CCP7PRH	A3E	1111111111111111	CCP9PRH	A86	1111111111111111	DMACNT3	AEA	0000000000000001
CCP7RAL	A40	0000000000000000	CCP9RAL	A88	0000000000000000			
CCP7RBL	A44	0000000000000000	CCP9RBL	A8C	0000000000000000			

**Legend:** x = unknown or indeterminate value; "-" = unimplemented bits. Address values are in hexadecimal. Reset values are in binary.

# dsPIC33CK256MP508 FAMILY

**TABLE 4-12: SFR BLOCK B00h**

Register	Address	All Resets	Register	Address	All Resets	Register	Address	All Resets
<b>ADC</b>			ADCMPL0	B44	0000000000000000	ADTRIG2H	B8A	0000000000000000
ADCON1L	B00	000-00000-000	ADCMPL1HI	B46	0000000000000000	ADTRIG3L	B8C	0000000000000000
ADCON1H	B02	-----011-----	ADCMPL2ENL	B48	0000000000000000	ADTRIG3H	B8E	0000000000000000
ADCON2L	B04	00-00000000000000	ADCMPL2ENH	B4A	-----0000000000	ADTRIG4L	B90	0000000000000000
ADCON2H	B06	00-00000000000000	ADCMPL2LO	B4C	0000000000000000	ADTRIG4H	B92	0000000000000000
ADCON3L	B08	0000000000000000	ADCMPL2HI	B4E	0000000000000000	ADTRIG5L	B94	0000000000000000
ADCON3H	B0A	000000000-000-xx	ADCMPL3ENL	B50	0000000000000000	ADTRIG5H	B96	0000000000000000
ADCON4L	B0C	-----000-000-xx	ADCMPL3ENH	B52	-----0000000000	ADTRIG6L	B98	0000000000000000
ADCON4H	B0E	00-----0000	ADCMPL3LO	B54	0000000000000000	ADCMPL0CON	BA0	0000000000000000
ADMOD0L	B10	0000000000000000	ADCMPL3HI	B56	0000000000000000	ADCMPL1CON	BA4	0000000000000000
ADMOD0H	B12	0000000000000000	ADFL0DAT	B68	0000000000000000	ADCMPL2CON	BA8	0000000000000000
ADMOD1L	B14	0000000000000000	ADFL0CON	B6A	xxx0000000000000	ADCMPL3CON	BAC	0000000000000000
ADMOD1H	B16	-----0000	ADFL1DAT	B6C	0000000000000000	ADLVLTRGL	BD0	0000000000000000
ADIEL	B20	xxxxxxxxxxxxxxxxxxxx	ADFL1CON	B6E	xxx0000000000000	ADLVLTRGH	BD2	-----xxxxxxxxxxxx
ADIEH	B22	-----xxxxxxxxxxxx	ADFL2DAT	B70	0000000000000000	ADCORE0L	BD4	0000000000000000
ADSTATL	B30	0000000000000000	ADFL2CON	B72	xxx0000000000000	ADCORE0H	BD6	0000001100000000
ADSTATH	B32	-----0000000000	ADFL3DAT	B74	0000000000000000	ADCORE1L	BD8	0000000000000000
ADCMPL0ENL	B38	0000000000000000	ADFL3CON	B76	xxx0000000000000	ADCORE1H	BDA	0000001100000000
ADCMPL0ENH	B3A	-----0000000000	ADTRIG0L	B80	0000000000000000	ADEIEL	BF0	xxxxxxxxxxxxxxxxxxxx
ADCMPL0LO	B3C	0000000000000000	ADTRIG0H	B82	0000000000000000	ADEIEH	BF2	-----xxxxxxxxxxxx
ADCMPL0HI	B3E	0000000000000000	ADTRIG1L	B84	0000000000000000	ADEISTATL	BF8	xxxxxxxxxxxxxxxxxxxx
ADCMPL1ENL	B40	0000000000000000	ADTRIG1H	B86	0000000000000000	ADEISTATH	BFA	-----xxxxxxxxxxxx
ADCMPL1ENH	B42	-----0000000000	ADTRIG2L	B88	0000000000000000			

**Legend:** x = unknown or indeterminate value; "-" = unimplemented bits. Address values are in hexadecimal. Reset values are in binary.



# dsPIC33CK256MP508 FAMILY

**TABLE 4-13: SFR BLOCK C00h**

Register	Address	All Resets	Register	Address	All Resets	Register	Address	All Resets
<b>ADC (Continued)</b>			ADCBUF16	C2C	0000000000000000	SLP1CONH	C92	----000-----
ADCON5L	C00	-----0-----	ADCBUF17	C2E	0000000000000000	SLP1DAT	C94	0000000000000000
ADCON5H	C02	----xxxx0-----	ADCBUF18	C30	0000000000000000	DAC2CONL	C98	000--000x0000000
ADCBUF0	C0C	0000000000000000	ADCBUF19	C32	0000000000000000	DAC2CONH	C9A	-----0000000000
ADCBUF1	C0E	0000000000000000	ADCBUF20	C34	0000000000000000	DAC2DATL	C9C	0000000000000000
ADCBUF2	C10	0000000000000000	ADCBUF21	C36	0000000000000000	DAC2DATH	C9E	0000000000000000
ADCBUF3	C12	0000000000000000	ADCBUF22	C38	0000000000000000	SLP2CONL	CA0	0000000000000000
ADCBUF4	C14	0000000000000000	ADCBUF23	C3A	0000000000000000	SLP2CONH	CA2	----000-----
ADCBUF5	C16	0000000000000000	ADCBUF24	C3C	0000000000000000	SLP2DAT	CA4	0000000000000000
ADCBUF6	C18	0000000000000000	ADCBUF25	C3E	0000000000000000	DAC3CONL	CA8	000--000x0000000
ADCBUF7	C1A	0000000000000000	<b>DAC</b>			DAC3CONH	CAA	-----0000000000
ADCBUF8	C1C	0000000000000000	DACCTRL1L	C80	--0-----0000-000	DAC3DATL	CAC	0000000000000000
ADCBUF9	C1E	0000000000000000	DACCTRL2L	C84	-----0001010101	DAC3DATH	CAE	0000000000000000
ADCBUF10	C20	0000000000000000	DACCTRL2H	C86	-----0010001010	SLP3CONL	CB0	0000000000000000
ADCBUF11	C22	0000000000000000	DAC1CONL	C88	000--000x0000000	SLP3CONH	CB2	----000-----
ADCBUF12	C24	0000000000000000	DAC1CONH	C8A	-----0000000000	SLP3DAT	CB4	0000000000000000
ADCBUF13	C26	0000000000000000	DAC1DATL	C8C	0000000000000000	VREGCON	CFC	-----00000000
ADCBUF14	C28	0000000000000000	DAC1DATH	C8E	0000000000000000			
ADCBUF15	C2A	0000000000000000	SLP1CONL	C90	0000000000000000			

**Legend:** x = unknown or indeterminate value; "-" = unimplemented bits. Address values are in hexadecimal. Reset values are in binary.

# dsPIC33CK256MP508 FAMILY

**TABLE 4-14: SFR BLOCK D00h**

Register	Address	All Resets	Register	Address	All Resets	Register	Address	All Resets
<b>PPS</b>			RPINR21	D2E	1111111111111111	RPOR4	D88	--000000--000000
RPCON	D00	----0-----	RPINR22	D30	1111111111111111	RPOR5	D8A	--000000--000000
RPINR0	D04	11111111-----	RPINR23	D32	-----11111111	RPOR6	D8C	--000000--000000
RPINR1	D06	1111111111111111	RPINR26	D38	-----11111111	RPOR7	D8E	--000000--000000
RPINR2	D08	11111111-----	RPINR27	D3A	1111111111111111	RPOR8	D90	--000000--000000
RPINR3	D0A	1111111111111111	RPINR29	D3E	1111111111111111	RPOR9	D92	--000000--000000
RPINR4	D0C	1111111111111111	RPINR30	D40	-----11111111	RPOR10	D94	--000000--000000
RPINR5	D0E	1111111111111111	RPINR32	D44	11111111-----	RPOR11	D96	--000000--000000
RPINR6	D10	1111111111111111	RPINR33	D46	-----11111111	RPOR12	D98	--000000--000000
RPINR7	D12	1111111111111111	RPINR37	D4E	1111111111111111	RPOR13	D9A	--000000--000000
RPINR8	D14	1111111111111111	RPINR38	D50	-----11111111	RPOR14	D9C	--000000--000000
RPINR9	D16	1111111111111111	RPINR42	D58	1111111111111111	RPOR15	D9E	--000000--000000
RPINR10	D18	1111111111111111	RPINR43	D5A	1111111111111111	RPOR16	DA0	--000000--000000
RPINR11	D1A	1111111111111111	RPINR44	D5C	1111111111111111	RPOR17	DA2	--000000--000000
RPINR12	D1C	1111111111111111	RPINR45	D5E	1111111111111111	RPOR18	DA4	--000000--000000
RPINR13	D1E	1111111111111111	RPINR46	D60	1111111111111111	RPOR19	DA6	--000000--000000
RPINR14	D20	1111111111111111	RPINR47	D62	1111111111111111	RPOR20	DA8	--000000--000000
RPINR15	D22	1111111111111111	RPINR48	D64	1111111111111111	RPOR21	DAA	--000000--000000
RPINR16	D24	1111111111111111	RPINR49	D66	-----11111111	RPOR22	DAC	--000000--000000
RPINR17	D26	1111111111111111	RPOR0	D80	--000000--000000	RPOR23	DAE	--000000--000000
RPINR18	D28	1111111111111111	RPOR1	D82	--000000--000000	RPOR24	DB0	--000000--000000
RPINR19	D2A	1111111111111111	RPOR2	D84	--000000--000000	RPOR25	DB2	--000000--000000
RPINR20	D2C	1111111111111111	RPOR3	D86	--000000--000000	RPOR26	DB4	--000000--000000

**Legend:** x = unknown or indeterminate value; "-" = unimplemented bits. Address values are in hexadecimal. Reset values are in binary.

# dsPIC33CK256MP508 FAMILY

**TABLE 4-15: SFR BLOCK E00h**

Register	Address	All Resets	Register	Address	All Resets	Register	Address	All Resets
<b>I/O Ports</b>			CNEN0B	E2C	0000000000000000	CNPUD	E5E	0000000000000000
ANSELA	E00	-----11111	CNSTATB	E2E	0000000000000000	CNPDD	E60	0000000000000000
TRISA	E02	-----11111	CNEN1B	E30	0000000000000000	CNCOND	E62	----0-----
PORTA	E04	-----xxxxx	CNFB	E32	0000000000000000	CNEN0D	E64	0000000000000000
LATA	E06	-----xxxxx	ANSELC	E38	-----11--1111	CNSTATD	E66	0000000000000000
ODCA	E08	-----00000	TRISC	E3A	1111111111111111	CNEN1D	E68	0000000000000000
CNPUA	E0A	-----00000	PORTC	E3C	xxxxxxxxxxxxxxxx	CNFD	E6A	0000000000000000
CNPDA	E0C	-----00000	LATC	E3E	xxxxxxxxxxxxxxxx	ANSELE	E70	-----1111
CNCONA	E0E	----0-----	ODCC	E40	0000000000000000	TRISE	E72	1111111111111111
CNEN0A	E10	-----00000	CNPUC	E42	0000000000000000	PORTE	E74	xxxxxxxxxxxxxxxx
CNSTATA	E12	-----00000	CNPDC	E44	0000000000000000	LATE	E76	xxxxxxxxxxxxxxxx
CNEN1A	E14	-----00000	CNCONC	E46	----0-----	ODCE	E78	0000000000000000
CNFA	E16	-----00000	CNEN0C	E48	0000000000000000	CNPUE	E7A	0000000000000000
ANSELB	E1C	-----111--11111	CNSTATC	E4A	0000000000000000	CNPDE	E7C	0000000000000000
TRISB	E1E	1111111111111111	CNEN1C	E4C	0000000000000000	CNCONE	E7E	----0-----
PORTB	E20	xxxxxxxxxxxxxxxx	CNFC	E4E	0000000000000000	CNEN0E	E80	0000000000000000
LATB	E22	xxxxxxxxxxxxxxxx	ANSELD	E54	--1-11-----	CNSTATE	E82	0000000000000000
ODCB	E24	0000000000000000	TRISD	E56	1111111111111111	CNEN1E	E84	0000000000000000
CNPUB	E26	0000000000000000	PORTD	E58	xxxxxxxxxxxxxxxx	CNFE	E86	0000000000000000
CNPDB	E28	0000000000000000	LATD	E5A	xxxxxxxxxxxxxxxx	<b>Memory BIST</b>		
CNCONB	E2A	----0-----	ODCD	E5C	0000000000000000	MBISTCON	EFC	-----00--0---1

**Legend:** x = unknown or indeterminate value; "-" = unimplemented bits. Address values are in hexadecimal. Reset values are in binary.

# dsPIC33CK256MP508 FAMILY

**TABLE 4-16: SFR BLOCK F00h**

Register	Address	All Resets	Register	Address	All Resets	Register	Address	All Resets
<b>UART3</b>			I2C3TRN	F70	-----11111111	WDTCONH	FB6	0000000000000000
U3MODE	F00	--000-00000000000	I2C3RCV	F74	-----00000000	<b>REFO</b>		
U3MODEH	F02	00----000000000000	<b>Reset and Oscillator</b>			REFOCONL	FB8	--000-00----0000
U3STA	F04	0000000010000000	RCON	F80	xx----x01x0xxxxx	REFOCONH	FBA	0000000000000000
U3STAH	F06	0000-00000101110	OSCCON	F84	0000-yyy0-0-0--0	REFOTRIMH	FBE	00000000-----
U3BRG	F08	0000000000000000	CLKDIV	F86	00110000--000001	<b>Processor</b>		
U3BRGH	F0A	-----0000	PLLFBD	F88	----000010010110	PCTRAPL	FC0	xxxxxxxxxxxxxxxx
U3RXREG	F0C	-----xxxxxxxx	PLLDIV	F8A	-----00-001-001	PCTRAPH	FC2	-----xxxxxxxx
U3TXREG	F10	-----xxxxxxxx	OSCTUN	F8C	-----000000	FEXL	FC4	xxxxxxxxxxxxxxxx
U3P1	F14	-----00000000	ACLKCON1	F8E	00-----0--000001	FEXH	FC6	-----xxxxxxxx
U3P2	F16	-----00000000	APLLFBD1	F90	----000010010110	FEX2L	FC8	xxxxxxxxxxxxxxxx
U3P3	F18	0000000000000000	APLLDIV1	F92	-----00-001-001	FEX2H	FCA	-----xxxxxxxx
U3P3H	F1A	-----00000000	CANCLKCON	F9A	0---0000-0000000	VISI	FCC	xxxxxxxxxxxxxxxx
U3TXCHK	F1C	-----00000000	DCOTUN	F9C	--000000--000000	DPCL	FCE	xxxxxxxxxxxxxxxx
U3RXCHK	F1E	-----00000000	DCOCON	F9E	--0-xxxx-----	DPCH	FD0	-----xxxxxxxx
U3SCCON	F20	-----00000-	<b>PMD</b>			APPO	FD2	xxxxxxxxxxxxxxxx
U3SCINT	F22	--00-000--00-000	PMD1	FA4	----000-00000-00	APPI	FD4	xxxxxxxxxxxxxxxx
U3INT	F24	-----00--0--	PMD2	FA6	-----00000000	APPS	FD6	-----xxxxx
<b>I2C3</b>			PMD3	FA8	-----00-0-000-	STROUTL	FD8	xxxxxxxxxxxxxxxx
I2C3CONL	F5C	--01000000000000	PMD4	FAA	-----0---	STROUTH	FDA	xxxxxxxxxxxxxxxx
I2C3CONH	F5E	-----0000000	PMD6	FAE	----0000-----	STROVCNT	FDC	xxxxxxxxxxxxxxxx
I2C3 STAT	F60	000--00000000000	PMD7	FB0	----000-----0---	JDATAL	FFA	0000000000000000
I2C3ADD	F64	-----0000000000	PMD8	FB2	--000--0--00000-	JDATAH	FFC	0000000000000000
I2C3MSK	F68	-----0000000000	<b>WDT</b>					
I2C3BRG	F6C	0000000000000000	WDTCONL	FB4	---000000000000			

**Legend:** x = unknown or indeterminate value; "-" = unimplemented bits; y = value set by Configuration bits. Address values are in hexadecimal. Reset values are in binary.

# dsPIC33CK256MP508 FAMILY

## 4.5.1 PAGED MEMORY SCHEME

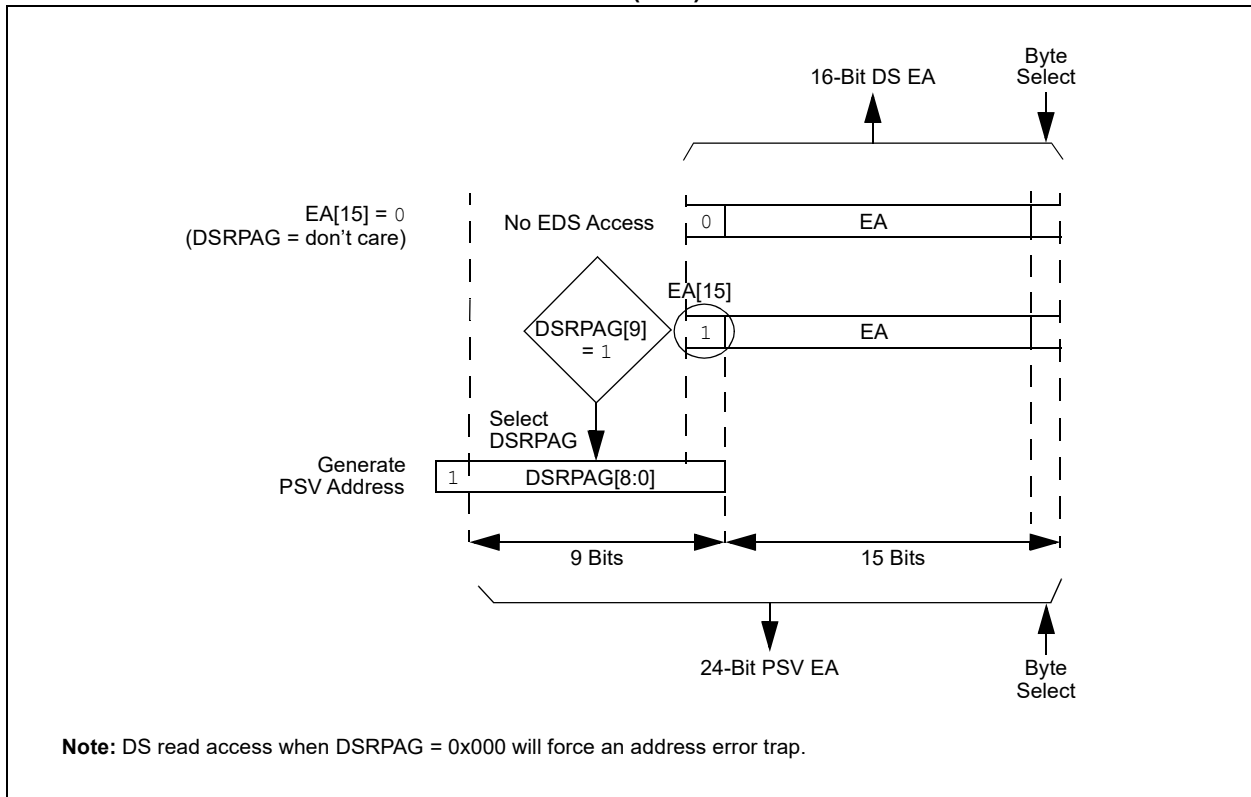
The dsPIC33CK256MP508 architecture extends the available Data Space through a paging scheme, which allows the available Data Space to be accessed using MOV instructions in a linear fashion for pre- and post-modified Effective Addresses (EAs). The upper half of the base Data Space address is used in conjunction with the Data Space Read Page (DSRPAG) register to form the Program Space Visibility (PSV) address.

The Data Space Read Page (DSRPAG) register is located in the SFR space. Construction of the PSV address is shown in Figure 4-11. When DSRPAG[9] = 1 and the base address bit, EA[15] = 1, the DSRPAG[8:0] bits are concatenated onto EA[14:0] to form the 24-bit PSV read address.

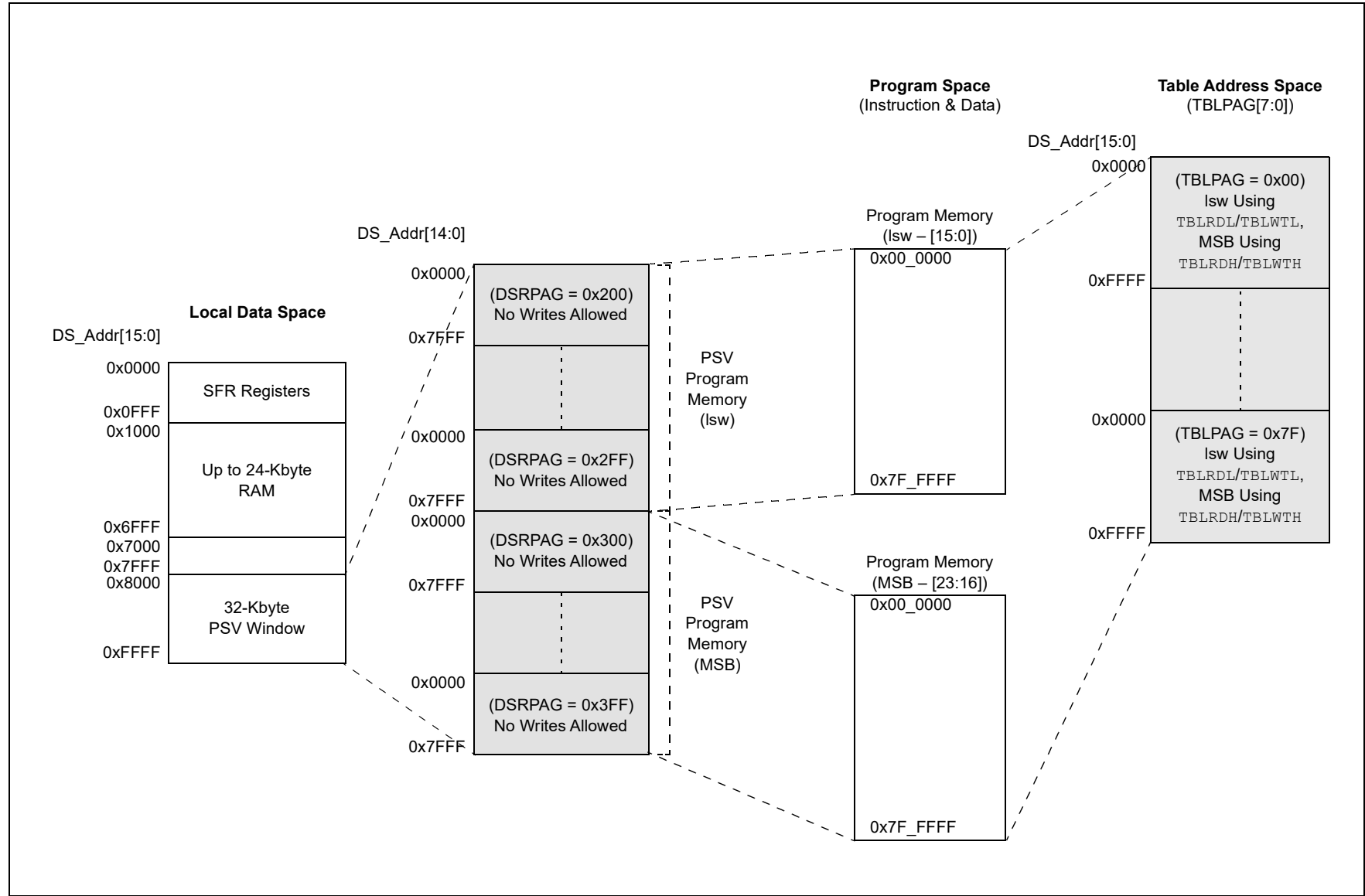
The paged memory scheme provides access to multiple 32-Kbyte windows in the PSV memory. The Data Space Read Page (DSRPAG) register, in combination with the upper half of the Data Space address, can provide up to 8 Mbytes of PSV address space. The paged data memory space is shown in Figure 4-12.

The Program Space (PS) can be accessed with a DSRPAG of 0x200 or greater. Only reads from PS are supported using the DSRPAG.

**FIGURE 4-11: PROGRAM SPACE VISIBILITY (PSV) READ ADDRESS GENERATION**



**FIGURE 4-12: PAGED DATA MEMORY SPACE**



# dsPIC33CK256MP508 FAMILY

When a PSV page overflow or underflow occurs, EA[15] is cleared as a result of the register indirect EA calculation. An overflow or underflow of the EA in the PSV pages can occur at the page boundaries when:

- The initial address, prior to modification, addresses the PSV page
- The EA calculation uses Pre- or Post-Modified Register Indirect Addressing; however, this does not include Register Offset Addressing

In general, when an overflow is detected, the DSRPAG register is incremented and the EA[15] bit is set to keep the base address within the PSV window. When an underflow is detected, the DSRPAG register is decremented and the EA[15] bit is set to keep the base

address within the PSV window. This creates a linear PSV address space, but only when using Register Indirect Addressing modes.

Exceptions to the operation described above arise when entering and exiting the boundaries of Page 0 and PSV spaces. [Table 4-17](#) lists the effects of overflow and underflow scenarios at different boundaries.

In the following cases, when overflow or underflow occurs, the EA[15] bit is set and the DSRPAG is not modified; therefore, the EA will wrap to the beginning of the current page:

- Register Indirect with Register Offset Addressing
- Modulo Addressing
- Bit-Reversed Addressing

**TABLE 4-17: OVERFLOW AND UNDERFLOW SCENARIOS AT PAGE 0 AND PSV SPACE BOUNDARIES<sup>(2,3,4)</sup>**

O/U, R/W	Operation	Before			After		
		DSRPAG	DS EA[15]	Page Description	DSRPAG	DS EA[15]	Page Description
O, Read	[++Wn] or [Wn++]	DSRPAG = 0x2FF	1	PSV: Last lsw page	DSRPAG = 0x300	1	PSV: First MSB page
O, Read	[Wn++]	DSRPAG = 0x3FF	1	PSV: Last MSB page	DSRPAG = 0x3FF	0	See <a href="#">Note 1</a>
U, Read	[--Wn] or [Wn--]	DSRPAG = 0x001	1	PSV page	DSRPAG = 0x001	0	See <a href="#">Note 1</a>
U, Read	[--Wn] or [Wn--]	DSRPAG = 0x200	1	PSV: First lsw page	DSRPAG = 0x200	0	See <a href="#">Note 1</a>
U, Read	[Wn--]	DSRPAG = 0x300	1	PSV: First MSB page	DSRPAG = 0x2FF	1	PSV: Last lsw page

**Legend:** O = Overflow, U = Underflow, R = Read, W = Write

**Note 1:** The Register Indirect Addressing now addresses a location in the base Data Space (0x0000-0x8000).

**2:** An EDS access, with DSRPAG = 0x000, will generate an address error trap.

**3:** Only reads from PS are supported using DSRPAG.

**4:** Pseudolinear Addressing is not supported for large offsets.

# dsPIC33CK256MP508 FAMILY

## 4.5.1.1 Extended X Data Space

The lower portion of the base address space range, between 0x0000 and 0x7FFF, is always accessible, regardless of the contents of the Data Space Read Page register. It is indirectly addressable through the register indirect instructions. It can be regarded as being located in the default EDS Page 0 (i.e., EDS address range of 0x000000 to 0x007FFF with the base address bit, EA[15] = 0, for this address range). However, Page 0 cannot be accessed through the upper 32 Kbytes, 0x8000 to 0xFFFF, of base Data Space in combination with DSRPAG = 0x00. Consequently, DSRPAG is initialized to 0x001 at Reset.

**Note 1:** DSRPAG should not be used to access Page 0. An EDS access with DSRPAG set to 0x000 will generate an address error trap.

**2:** Clearing the DSRPAG in software has no effect.

The remaining PSV pages are only accessible using the DSRPAG register in combination with the upper 32 Kbytes, 0x8000 to 0xFFFF, of the base address, where the base address bit, EA[15] = 1.

## 4.5.1.2 Software Stack

The W15 register serves as a dedicated Software Stack Pointer (SSP), and is automatically modified by exception processing, subroutine calls and returns; however, W15 can be referenced by any instruction in the same manner as all other W registers. This simplifies reading, writing and manipulating the Stack Pointer (for example, creating stack frames).

**Note:** To protect against misaligned stack accesses, W15[0] is fixed to '0' by the hardware.

W15 is initialized to 0x1000 during all Resets. This address ensures that the SSP points to valid RAM in all dsPIC33CK256MP508 devices and permits stack availability for non-maskable trap exceptions. These can occur before the SSP is initialized by the user software. You can reprogram the SSP during initialization to any location within Data Space.

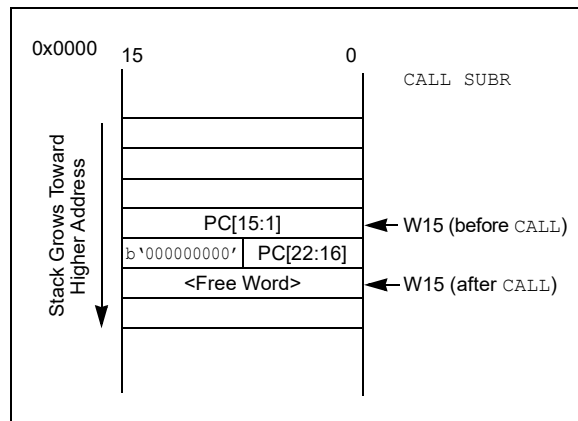
The Software Stack Pointer always points to the first available free word and fills the software stack, working from lower toward higher addresses. Figure 4-13 illustrates how it pre-decrements for a stack pop (read) and post-increments for a stack push (writes).

When the PC is pushed onto the stack, PC[15:0] are pushed onto the first available stack word, then PC[22:16] are pushed into the second available stack location. For a PC push during any CALL instruction, the MSB of the PC is zero-extended before the push, as shown in Figure 4-13. During exception processing, the MSB of the PC is concatenated with the lower eight bits of the CPU STATUS Register, SR. This allows the contents of SRL to be preserved automatically during interrupt processing.

**Note 1:** To maintain system Stack Pointer (W15) coherency, W15 is never subject to (EDS) paging, and is therefore, restricted to an address range of 0x0000 to 0xFFFF. The same applies to the W14 when used as a Stack Frame Pointer (SFA = 1).

**2:** As the stack can be placed in, and can access X and Y spaces, care must be taken regarding its use, particularly with regard to local automatic variables in a C development environment

**FIGURE 4-13: CALL STACK FRAME**





# dsPIC33CK256MP508 FAMILY

## 4.5.2 INSTRUCTION ADDRESSING MODES

The addressing modes shown in [Table 4-18](#) form the basis of the addressing modes optimized to support the specific features of individual instructions. The addressing modes provided in the `MAC` class of instructions differ from those in the other instruction types.

### 4.5.2.1 File Register Instructions

Most file register instructions use a 13-bit address field (`f`) to directly address data present in the first 8192 bytes of data memory (Near Data Space). Most file register instructions employ a Working register, `W0`, which is denoted as `WREG` in these instructions. The destination is typically either the same file register or `WREG` (with the exception of the `MUL` instruction), which writes the result to a register or register pair. The `MOV` instruction allows additional flexibility and can access the entire Data Space.

### 4.5.2.2 MCU Instructions

The three-operand MCU instructions are of the form:

Operand 3 = Operand 1 <function> Operand 2

where `Operand 1` is always a Working register (that is, the addressing mode can only be Register Direct), which is referred to as `Wb`. `Operand 2` can be a `W` register fetched from data memory or a 5-bit literal. The result location can either be a `W` register or a data memory location. The following addressing modes are supported by MCU instructions:

- Register Direct
- Register Indirect
- Register Indirect Post-Modified
- Register Indirect Pre-Modified
- 5-Bit or 10-Bit Literal

**Note:** Not all instructions support all the addressing modes given above. Individual instructions can support different subsets of these addressing modes.

**TABLE 4-18: FUNDAMENTAL ADDRESSING MODES SUPPORTED**

Addressing Mode	Description
File Register Direct	The address of the file register is specified explicitly.
Register Direct	The contents of a register are accessed directly.
Register Indirect	The contents of <code>Wn</code> form the Effective Address (EA).
Register Indirect Post-Modified	The contents of <code>Wn</code> form the EA. <code>Wn</code> is post-modified (incremented or decremented) by a constant value.
Register Indirect Pre-Modified	<code>Wn</code> is pre-modified (incremented or decremented) by a signed constant value to form the EA.
Register Indirect with Register Offset (Register Indexed)	The sum of <code>Wn</code> and <code>Wb</code> forms the EA.
Register Indirect with Literal Offset	The sum of <code>Wn</code> and a literal forms the EA.

# dsPIC33CK256MP508 FAMILY

---

## 4.5.2.3 Move and Accumulator Instructions

Move instructions, and the DSP accumulator class of instructions, provide a greater degree of addressing flexibility than other instructions. In addition to the addressing modes supported by most MCU instructions, move and accumulator instructions also support Register Indirect with Register Offset Addressing mode, also referred to as Register Indexed mode.

**Note:** For the `MOV` instructions, the addressing mode specified in the instruction can differ for the source and destination EA. However, the 4-bit `Wb` (Register Offset) field is shared by both source and destination (but typically only used by one).

In summary, the following addressing modes are supported by move and accumulator instructions:

- Register Direct
- Register Indirect
- Register Indirect Post-Modified
- Register Indirect Pre-Modified
- Register Indirect with Register Offset (Indexed)
- Register Indirect with Literal Offset
- 8-Bit Literal
- 16-Bit Literal

**Note:** Not all instructions support all the addressing modes given above. Individual instructions may support different subsets of these addressing modes.

## 4.5.2.4 MAC Instructions

The dual source operand DSP instructions (`CLR`, `ED`, `EDAC`, `MAC`, `MPY`, `MPY.N`, `MOVSAC` and `MSC`), also referred to as `MAC` instructions, use a simplified set of addressing modes to allow the user application to effectively manipulate the Data Pointers through register indirect tables.

The two-source operand prefetch registers must be members of the set {`W8`, `W9`, `W10`, `W11`}. For data reads, `W8` and `W9` are always directed to the X RAGU, and `W10` and `W11` are always directed to the Y AGU. The Effective Addresses generated (before and after modification) must therefore, be valid addresses within X Data Space for `W8` and `W9`, and Y Data Space for `W10` and `W11`.

**Note:** Register Indirect with Register Offset Addressing mode is available only for `W9` (in X space) and `W11` (in Y space).

In summary, the following addressing modes are supported by the `MAC` class of instructions:

- Register Indirect
- Register Indirect Post-Modified by 2
- Register Indirect Post-Modified by 4
- Register Indirect Post-Modified by 6
- Register Indirect with Register Offset (Indexed)

## 4.5.2.5 Other Instructions

Besides the addressing modes outlined previously, some instructions use literal constants of various sizes. For example, `BRA` (branch) instructions use 16-bit signed literals to specify the branch destination directly, whereas the `DISI` instruction uses a 14-bit unsigned literal field. In some instructions, such as `ULNK`, the source of an operand or result is implied by the opcode itself. Certain operations, such as a `NOP`, do not have any operands.

## 4.5.3 MODULO ADDRESSING

Modulo Addressing mode is a method of providing an automated means to support circular data buffers using hardware. The objective is to remove the need for software to perform data address boundary checks when executing tightly looped code, as is typical in many DSP algorithms.

Modulo Addressing can operate in either Data or Program Space (since the Data Pointer mechanism is essentially the same for both). One circular buffer can be supported in each of the X (which also provides the pointers into Program Space) and Y Data Spaces. Modulo Addressing can operate on any W Register Pointer. However, it is not advisable to use W14 or W15 for Modulo Addressing since these two registers are used as the Stack Frame Pointer and Stack Pointer, respectively.

In general, any particular circular buffer can be configured to operate in only one direction, as there are certain restrictions on the buffer start address (for incrementing buffers) or end address (for decrementing buffers), based upon the direction of the buffer.

The only exception to the usage restrictions is for buffers that have a power-of-two length. As these buffers satisfy the start and end address criteria, they can operate in a Bidirectional mode (that is, address boundary checks are performed on both the lower and upper address boundaries).

### 4.5.3.1 Start and End Address

The Modulo Addressing scheme requires that a starting and ending address be specified and loaded into the 16-bit Modulo Buffer Address registers: XMODSRT, XMODEND, YMODSRT and YMODEND (see Table 4-2).

**Note:** Y space Modulo Addressing EA calculations assume word-sized data (LSb of every EA is always clear).

The length of a circular buffer is not directly specified. It is determined by the difference between the corresponding start and end addresses. The maximum possible length of the circular buffer is 32K words (64 Kbytes).

### 4.5.3.2 W Address Register Selection

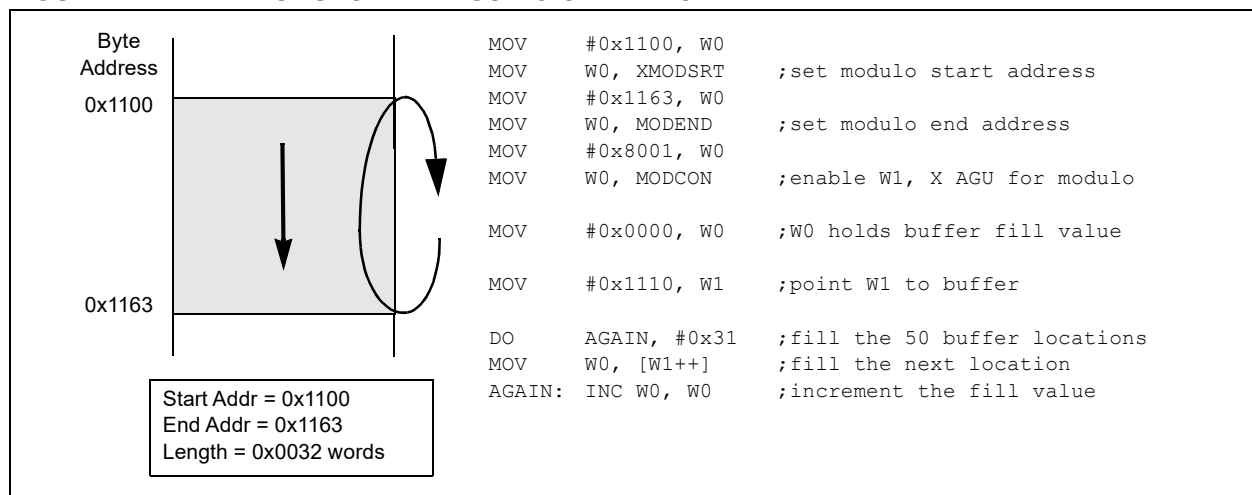
The Modulo and Bit-Reversed Addressing Control register, MODCON[15:0], contains enable flags, as well as a W register field to specify the W Address registers. The XWM and YWM fields select the registers that operate with Modulo Addressing:

- If XWM = 1111, X RAGU and X WAGU Modulo Addressing is disabled
- If YWM = 1111, Y AGU Modulo Addressing is disabled

The X Address Space Pointer W (XWM) register, to which Modulo Addressing is to be applied, is stored in MODCON[3:0] (see Table 4.2). Modulo Addressing is enabled for X Data Space when XWM is set to any value other than '1111' and the XMODEN bit is set (MODCON[15]).

The Y Address Space Pointer W (YWM) register, to which Modulo Addressing is to be applied, is stored in MODCON[7:4]. Modulo Addressing is enabled for Y Data Space when YWM is set to any value other than '1111' and the YMODEN bit (MODCON[14]) is set.

**FIGURE 4-14: MODULO ADDRESSING OPERATION EXAMPLE**



# dsPIC33CK256MP508 FAMILY

---

## 4.5.3.3 Modulo Addressing Applicability

Modulo Addressing can be applied to the Effective Address (EA) calculation associated with any W register. Address boundaries check for addresses equal to:

- The upper boundary addresses for incrementing buffers
- The lower boundary addresses for decrementing buffers

It is important to realize that the address boundaries check for addresses less than, or greater than, the upper (for incrementing buffers) and lower (for decrementing buffers) boundary addresses (not just equal to). Address changes can, therefore, jump beyond boundaries and still be adjusted correctly.

**Note:** The modulo corrected Effective Address is written back to the register only when Pre-Modify or Post-Modify Addressing mode is used to compute the Effective Address. When an address offset (such as  $[W7 + W2]$ ) is used, Modulo Addressing correction is performed, but the contents of the register remain unchanged.

## 4.5.4 BIT-REVERSED ADDRESSING

Bit-Reversed Addressing mode is intended to simplify data reordering for radix-2 FFT algorithms. It is supported by the X AGU for data writes only.

The modifier, which can be a constant value or register contents, is regarded as having its bit order reversed. The address source and destination are kept in normal order. Thus, the only operand requiring reversal is the modifier.

## 4.5.4.1 Bit-Reversed Addressing Implementation

Bit-Reversed Addressing mode is enabled in any of these situations:

- BWMx bits (W register selection) in the MODCON register are any value other than '1111' (the stack cannot be accessed using Bit-Reversed Addressing)
- The BREN bit is set in the XBREV register
- The addressing mode used is Register Indirect with Pre-Increment or Post-Increment

If the length of a bit-reversed buffer is  $M = 2^N$  bytes, the last 'N' bits of the data buffer start address must be zeros.

XB[14:0] is the Bit-Reversed Addressing modifier, or 'pivot point', which is typically a constant. In the case of an FFT computation, its value is equal to half of the FFT data buffer size.

**Note:** All bit-reversed EA calculations assume word-sized data (LSb of every EA is always clear). The XB value is scaled accordingly to generate compatible (byte) addresses.

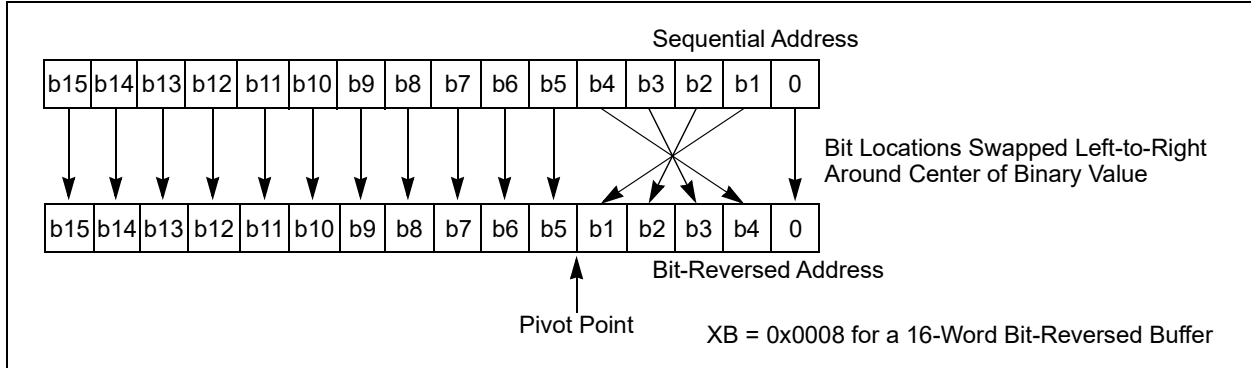
When enabled, Bit-Reversed Addressing is executed only for Register Indirect with Pre-Increment or Post-Increment Addressing and word-sized data writes. It does not function for any other addressing mode or for byte-sized data and normal addresses are generated instead. When Bit-Reversed Addressing is active, the W Address Pointer is always added to the address modifier (XB) and the offset associated with the Register Indirect Addressing mode is ignored. In addition, as word-sized data are a requirement, the LSb of the EA is ignored (and always clear).

**Note:** Modulo Addressing and Bit-Reversed Addressing can be enabled simultaneously using the same W register, but Bit-Reversed Addressing operation will always take precedence for data writes when enabled.

If Bit-Reversed Addressing has already been enabled by setting the BREN (XBREV[15]) bit, a write to the XBREV register should not be immediately followed by an indirect read operation using the W register that has been designated as the Bit-Reversed Pointer.

# dsPIC33CK256MP508 FAMILY

**FIGURE 4-15: BIT-REVERSED ADDRESSING EXAMPLE**



**TABLE 4-19: BIT-REVERSED ADDRESSING SEQUENCE (16-ENTRY)**

Normal Address					Bit-Reversed Address				
A3	A2	A1	A0	Decimal	A3	A2	A1	A0	Decimal
0	0	0	0	0	0	0	0	0	0
0	0	0	1	1	1	0	0	0	8
0	0	1	0	2	0	1	0	0	4
0	0	1	1	3	1	1	0	0	12
0	1	0	0	4	0	0	1	0	2
0	1	0	1	5	1	0	1	0	10
0	1	1	0	6	0	1	1	0	6
0	1	1	1	7	1	1	1	0	14
1	0	0	0	8	0	0	0	1	1
1	0	0	1	9	1	0	0	1	9
1	0	1	0	10	0	1	0	1	5
1	0	1	1	11	1	1	0	1	13
1	1	0	0	12	0	0	1	1	3
1	1	0	1	13	1	0	1	1	11
1	1	1	0	14	0	1	1	1	7
1	1	1	1	15	1	1	1	1	15

# dsPIC33CK256MP508 FAMILY

## 4.5.5 INTERFACING PROGRAM AND DATA MEMORY SPACES

The dsPIC33CK256MP508 family architecture uses a 24-bit wide Program Space (PS) and a 16-bit wide Data Space (DS). The architecture is also a modified Harvard scheme, meaning that data can also be present in the Program Space. To use these data successfully, they must be accessed in a way that preserves the alignment of information in both spaces.

Aside from normal execution, the architecture of the dsPIC33CK256MP508 family devices provides two methods by which Program Space can be accessed during operation:

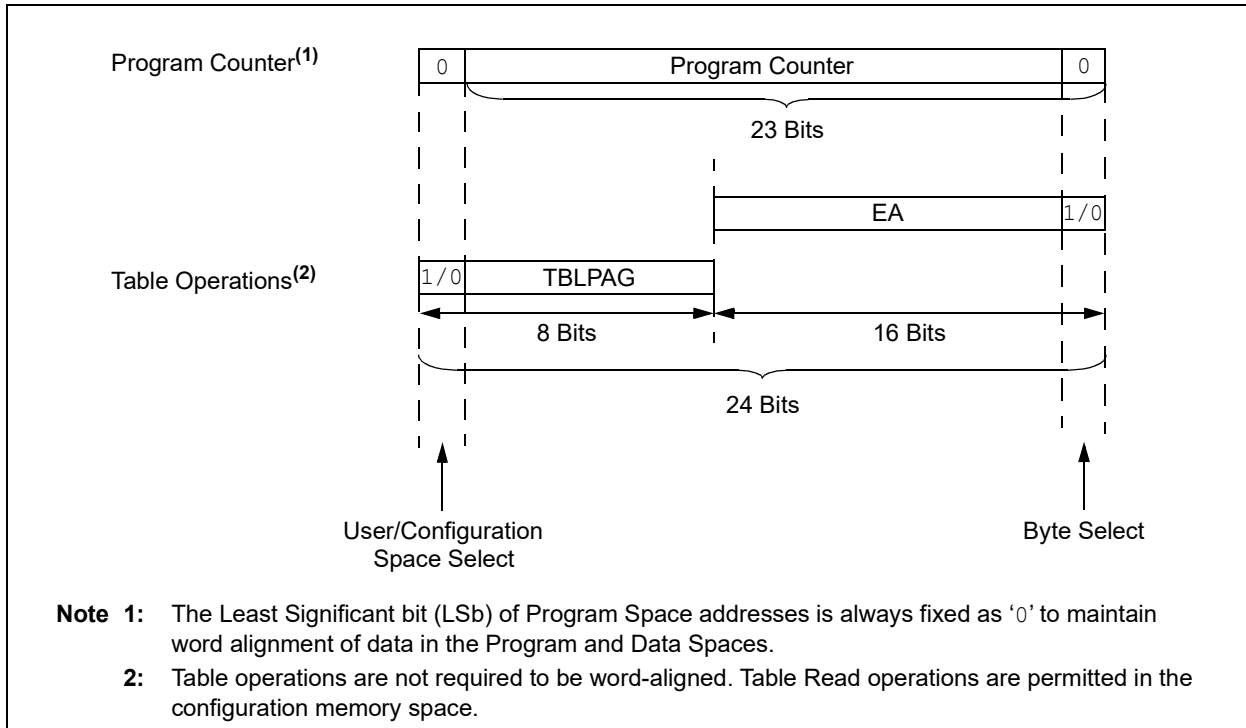
- Using table instructions to access individual bytes or words anywhere in the Program Space
- Remapping a portion of the Program Space into the Data Space (Program Space Visibility)

Table instructions allow an application to read or write to small areas of the program memory. This capability makes the method ideal for accessing data tables that need to be updated periodically. It also allows access to all bytes of the program word. The remapping method allows an application to access a large block of data on a read-only basis, which is ideal for look-ups from a large table of static data. The application can only access the least significant word of the program word.

**TABLE 4-20: PROGRAM SPACE ADDRESS CONSTRUCTION**

Access Type	Access Space	Program Space Address				
		[23]	[22:16]	[15]	[14:1]	[0]
Instruction Access (Code Execution)	User	0	PC[22:1]			0
		0xxx xxxx xxxxx xxxxx xxxxx xxx0				
TBLRD/TBLWT (Byte/Word Read/Write)	User	TBLPAG[7:0]		Data EA[15:0]		
		0xxx xxxxx xxxxx xxxxx xxxxx xxxxx				
	Configuration	TBLPAG[7:0]		Data EA[15:0]		
		1xxx xxxxx xxxxx xxxxx xxxxx xxxxx				

**FIGURE 4-16: DATA ACCESS FROM PROGRAM SPACE ADDRESS GENERATION**



## 4.5.5.1 Data Access from Program Memory Using Table Instructions

The `TBLRDL` and `TBLWTL` instructions offer a direct method of reading or writing the lower word of any address within the Program Space without going through Data Space. The `TBLRDH` and `TBLWTH` instructions are the only method to read or write the upper eight bits of a Program Space word as data.

The PC is incremented by two for each successive 24-bit program word. This allows program memory addresses to directly map to Data Space addresses. Program memory can thus be regarded as two 16-bit wide word address spaces, residing side by side, each with the same address range. `TBLRDL` and `TBLWTL` access the space that contains the least significant data word. `TBLRDH` and `TBLWTH` access the space that contains the upper data byte.

Two table instructions are provided to move byte or word-sized (16-bit) data to and from Program Space. Both function as either byte or word operations.

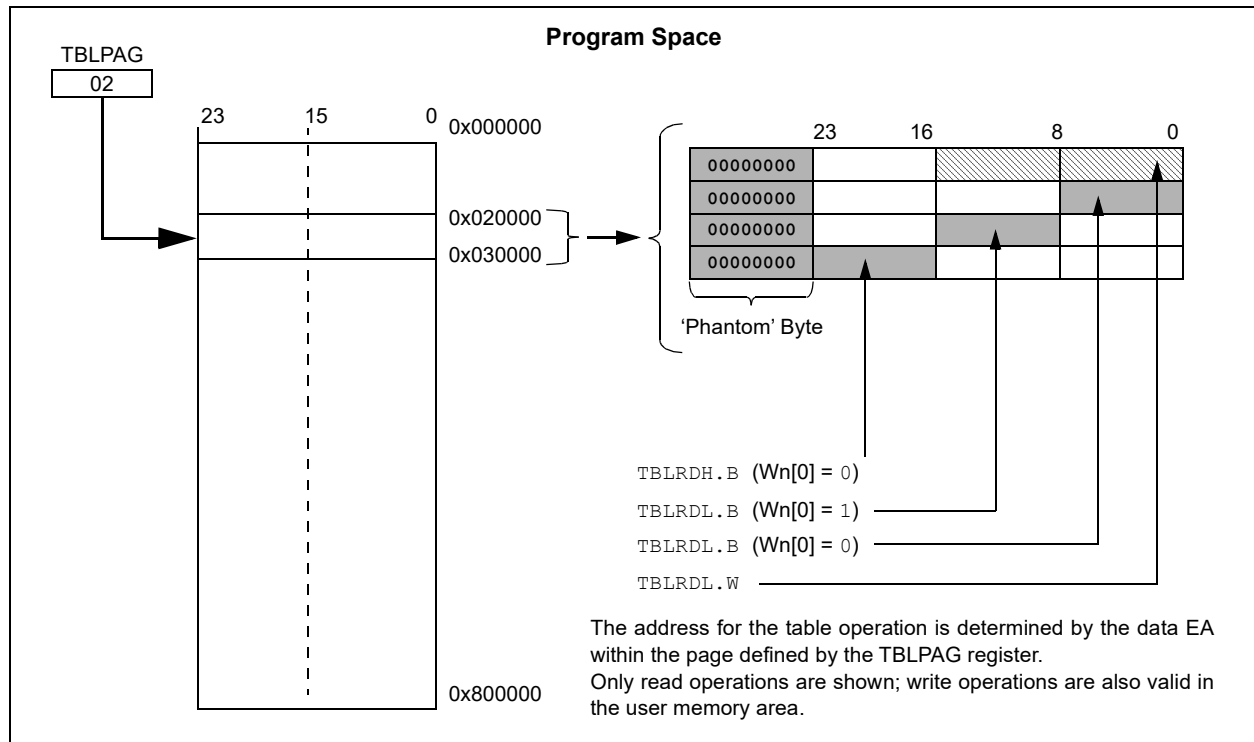
- `TBLRDL` (Table Read Low):
  - In Word mode, this instruction maps the lower word of the Program Space location (P[15:0]) to a data address (D[15:0])
  - In Byte mode, either the upper or lower byte of the lower program word is mapped to the lower byte of a data address. The upper byte is selected when Byte Select is '1'; the lower byte is selected when it is '0'.

- `TBLRDH` (Table Read High):
  - In Word mode, this instruction maps the entire upper word of a program address (P[23:16]) to a data address. The 'phantom' byte (D[15:8]) is always '0'.
  - In Byte mode, this instruction maps the upper or lower byte of the program word to D[7:0] of the data address in the `TBLRDL` instruction. The data are always '0' when the upper 'phantom' byte is selected (Byte Select = 1).

In a similar fashion, two table instructions, `TBLWTH` and `TBLWTL`, are used to write individual bytes or words to a Program Space address. The details of their operation are explained in [Section 5.0 "Flash Program Memory"](#).

For all table operations, the area of program memory space to be accessed is determined by the Table Page register (TBLPAG). TBLPAG covers the entire program memory space of the device, including user application and configuration spaces. When `TBLPAG[7] = 0`, the table page is located in the user memory space. When `TBLPAG[7] = 1`, the page is located in configuration space.

**FIGURE 4-17: ACCESSING PROGRAM MEMORY WITH TABLE INSTRUCTIONS**



# dsPIC33CK256MP508 FAMILY

---

NOTES:



## 5.0 FLASH PROGRAM MEMORY

**Note 1:** This data sheet summarizes the features of the dsPIC33CK256MP508 family of devices. It is not intended to be a comprehensive reference source. To complement the information in this data sheet, refer to “Dual Partition Flash Program Memory” ([www.microchip.com/DS70005156](http://www.microchip.com/DS70005156)) in the “dsPIC33/PIC24 Family Reference Manual”.

**2:** Some registers and associated bits described in this section may not be available on all devices.

The dsPIC33CK256MP508 family devices contain internal Flash program memory for storing and executing application code. The memory is readable, writable and erasable during normal operation over the entire VDD range.

Flash memory can be programmed in three ways:

- In-Circuit Serial Programming™ (ICSP™) programming capability
- Enhanced In-Circuit Serial Programming (Enhanced ICSP)
- Run-Time Self-Programming (RTSP)

ICSP allows for a dsPIC33CK256MP508 family device to be serially programmed while in the end application circuit. This is done with a Programming Clock and Programming Data (PGCx/PGDx) line, and three other lines for power (VDD), ground (VSS) and Master Clear (MCLR). This allows customers to manufacture boards with unprogrammed devices and then program the

device just before shipping the product. This also allows the most recent firmware or a custom firmware to be programmed.

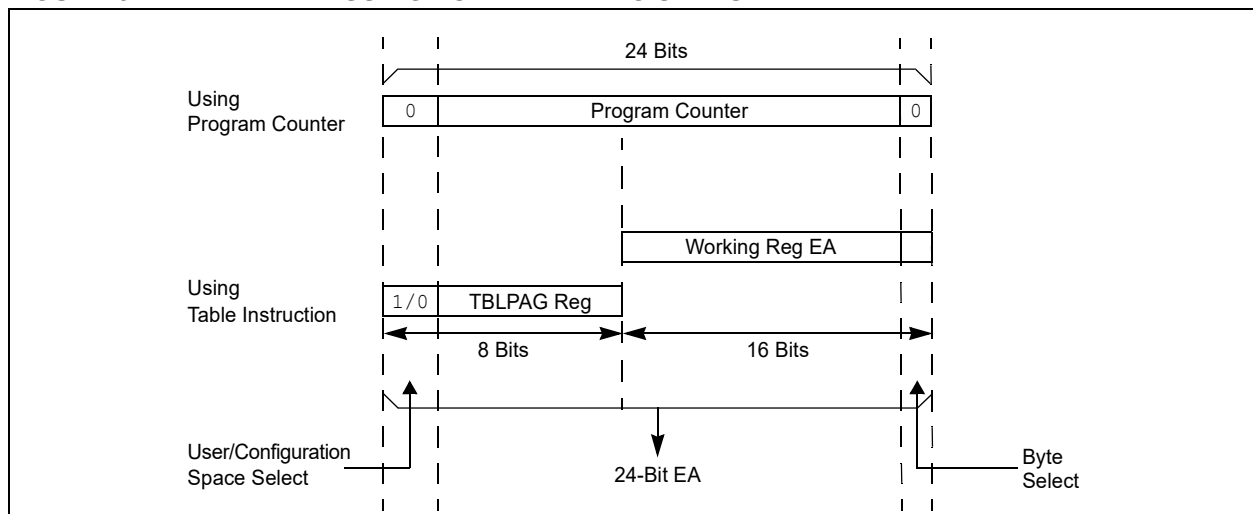
Enhanced In-Circuit Serial Programming uses an on-board bootloader, known as the Program Executive, to manage the programming process. Using an SPI data frame format, the Program Executive can erase, program and verify program memory. For more information on Enhanced ICSP, see the device programming specification.

RTSP is accomplished using TBLRD (Table Read) and TBLWT (Table Write) instructions. With RTSP, the user application can write program memory data, two instruction words or a row at a time, and erase a program memory page.

### 5.1 Table Instructions and Flash Programming

Regardless of the method used, all programming of Flash memory is done with the Table Read and Table Write instructions. These allow direct read and write access to the program memory space from the data memory while the device is in normal operating mode. The 24-bit target address in the program memory is formed using bits[7:0] of the TBLPAG register and the Effective Address (EA) from a W register, specified in the table instruction, as shown in Figure 5-1. The TBLRDL and TBLWTL instructions are used to read or write to bits[15:0] of program memory. TBLRDL and TBLWTL can access program memory in both Word and Byte modes. The TBLRDH and TBLWTH instructions are used to read or write to bits[23:16] of program memory. TBLRDH and TBLWTH can also access program memory in Word or Byte mode.

**FIGURE 5-1: ADDRESSING FOR TABLE REGISTERS**



# dsPIC33CK256MP508 FAMILY

## 5.2 RTSP Operation

The dsPIC33CK256MP508 family Flash program memory array is organized into rows of 128 instructions or 384 bytes. RTSP allows the user application to erase a single page (eight rows or 1024 instructions) of memory at a time and to program one row at a time. It is possible to program two instructions at a time as well.

The page erase and single row write blocks are edge-aligned, from the beginning of program memory, on boundaries of 3072 bytes and 384 bytes, respectively. Table 33-19 in Section 33.0 “**Electrical Characteristics**” lists the typical erase and programming times.

Row programming is performed by loading 384 bytes into data memory and then loading the address of the first byte in that row into the NVMSRCADRL/H register. Once the write has been initiated, the device will automatically load the write latches, and increment the NVMSRCADRL/H and the NVADR(U) registers until all bytes have been programmed. The RPDF bit (NVMCON[9]) selects the format of the stored data in RAM to be either compressed or uncompressed. See Figure 5-2 for data formatting. Compressed data help to reduce the amount of required RAM by using the upper byte of the second word for the MSB of the second instruction.

The basic sequence for RTSP word programming is to use the TBLWTL and TBLWTH instructions to load two of the 24-bit instructions into the write latches found in configuration memory space. Refer to Figure 4-1 through Figure 4-5 for write latch addresses. Programming is performed by unlocking and setting the control bits in the NVMCON register as follows:

1. Write 0x55 to NVMKEY.
2. Write 0xAA to NVMKEY.
3. Set the WR bit (NVMCON[15]) as a single operation.

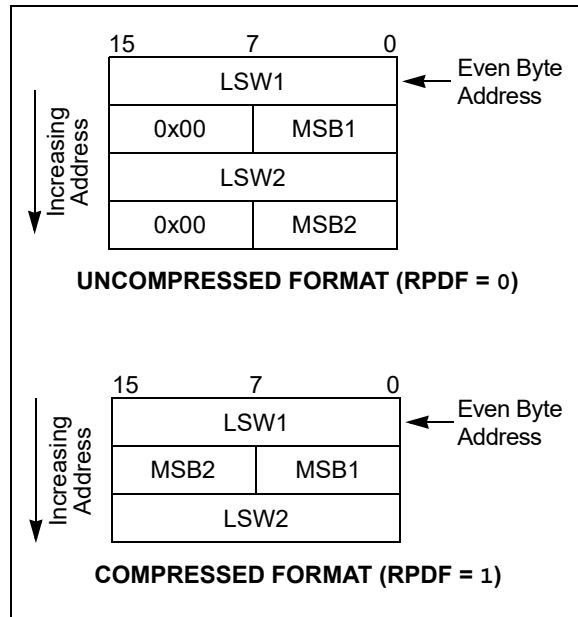
All erase and program operations may optionally use the NVM interrupt to signal the successful completion of the operation. For example, when performing Flash write operations on the Inactive Partition in Dual Partition mode, where the CPU remains running, it is necessary to wait for the NVM interrupt before programming the next block of Flash program memory.

**Note:** MPLAB® XC16 provides a built-in C language function for unlocking and modifying the NVMCON register:

```
__builtin_write_NVM()
```

For more information, see the “MPLAB® XC16 C Compiler User’s Guide” (DS50002071).

**FIGURE 5-2: UNCOMPRESSED/COMPRESSED FORMAT**



## 5.3 Programming Operations

A complete programming sequence is necessary for programming or erasing the internal Flash in RTSP mode. The processor stalls (waits) until the programming operation is finished. Setting the WR bit (NVMCON[15]) starts the operation and the WR bit is automatically cleared when the operation is finished.

### 5.3.1 PROGRAMMING ALGORITHM FOR FLASH PROGRAM MEMORY

Programmers can program two adjacent words (24 bits x 2) of Program Flash Memory at a time on every other word address boundary (0x000002, 0x000006, 0x00000A, etc.). To do this, it is necessary to erase the page that contains the desired address of the location the user wants to change. For protection against accidental operations, the write initiate sequence for NVMKEY must be used to allow any erase or program operation to proceed. After the programming command has been executed, the user application must wait for the programming time until programming is complete. The two instructions following the start of the programming sequence should be NOPs. Refer to [Example 5-1](#) for Flash read and write operations.

#### EXAMPLE 5-1: FLASH WRITE/READ

```
//////////Flash write ////////////
//Sample code for writing 0x123456 to address locations 0x10000 / 10002
NVMCON = 0x4001;
TBLPAG = 0xFA; // write latch upper address
NVMADR = 0x0000; // set target write address of general segment
NVMADRU = 0x0001;
__builtin_tblwtl(0, 0x3456); // load write latches
__builtin_tblwth (0,0x12);

__builtin_tblwtl(2, 0x3456); // load write latches
__builtin_tblwth (2,0x12);

asm volatile ("disi #5");
__builtin_write_NVM();
while ( _WR == 1 ) ;
//////////Flash Read//////////
//Sample code to read the Flash content of address 0x10000
// readDataL/ readDataH variables need to defined
TBLPAG = 0x0001;
readDataL = __builtin_tblrld(0x0000);
readDataH = __builtin_tblrhd(0x0000);
```

# dsPIC33CK256MP508 FAMILY

---

## 5.3.2 ERROR CORRECTING CODE (ECC)

In order to improve program memory performance and durability, these devices include Error Correcting Code (ECC) functionality as an integral part of the Flash memory controller. ECC can determine the presence of single-bit errors in program data, including which bit is in error, and correct the data automatically without user intervention. ECC cannot be disabled.

When data are written to program memory, ECC generates a 7-bit Hamming code parity value for every two (24-bit) instruction words. The data are stored in blocks of 48 data bits and 7 parity bits; parity data are not memory-mapped and are inaccessible. When the data are read back, the ECC calculates the parity on them and compares them to the previously stored parity value. If a parity mismatch occurs, there are two possible outcomes:

- Single-bit error has occurred and has been automatically corrected on read-back.
- Double-bit error has occurred and the read data are not changed.

Single-bit error occurrence can be identified by the state of the ECCSBEIF (IFS0[13]) bit. An interrupt can be generated when the corresponding interrupt enable bit is set, ECCSBEIE (IEC0[13]). The ECCSTATL register contains the parity information for single-bit errors. The SECOUT[7:0] bits field contains the expected calculated SEC parity and the SECIN[7:0] bits contain the actual value from a Flash read operation. The SECSYNDx bits (ECCSTATH[7:0]) indicate the bit position of the single-bit error within the 48-bit pair of instruction words. When no error is present, SECINx equals SECOUTx and SECSYNDx is zero. The ECCSTATL and ECCSTATH registers will only update and be valid when an error has occurred, or when including fault injection is enabled and an ECCADDR match occurs.

Double-bit errors result in a generic hard trap. The ECCDBE bit (INTCON4[1]) will be set to identify the source of the hard trap. If no Interrupt Service Routine is implemented for the hard trap, a device Reset will also occur. The ECCSTATH register contains double-bit error status information. The DEDOUT bit is the expected calculated DED parity and DEDIN bit is the actual value from a Flash read operation. When no error is present, DEDIN equals DEDOUT.

## 5.3.3 ECC FAULT INJECTION

To test Fault handling, an EEC error can be generated. Both single and double-bit errors can be generated in both the read and write data paths. Read path Fault injection first reads the Flash data and then modifies them prior to entering the ECC logic. Write path Fault injection modifies the actual data prior to them being written into the target Flash and will cause an EEC error on a subsequent Flash read. The following procedure is used to inject a Fault:

1. Load the Flash target address into the ECCADDR register.
2. Select 1st Fault bit determined by FLT1PTRx (ECCCONH[7:0]). The target bit is inverted to create the Fault.
3. If a double Fault is desired, select the 2nd Fault bit determined by FLT2PTRx (ECCCONH[15:8]); otherwise, set to all '1's.
4. Write 0x55 to NVMKEY.
5. Write 0xAA to NVMKEY.
6. Set the FLTINJ bit (ECCCONL[0]) in a single operation to enable the ECC Fault injection logic.
7. Perform a read or write to the Flash target address.

# dsPIC33CK256MP508 FAMILY

## 5.4 Flash OTP by ICSP™ Write Inhibit

ICSP Write Inhibit is an access restriction feature that, when activated, restricts all of Flash memory. Once activated, ICSP Write Inhibit permanently prevents ICSP Flash programming and erase operations, and cannot be deactivated. This feature is intended to prevent alteration of Flash memory contents, with behavior similar to One-Time-Programmable (OTP) devices.

RTSP, including erase and programming operations, is not restricted when ICSP Write Inhibit is activated; however, code to perform these actions must be programmed into the device before ICSP Write Inhibit is activated. This allows for a bootloader-type application to alter Flash contents with ICSP Write Inhibit activated.

Entry into ICSP and Enhanced ICSP modes is not affected by ICSP Write Inhibit. In these modes, it will continue to be possible to read configuration memory space and any user memory space regions which are not code protected. With ICSP writes inhibited, an attempt to set WR (NVMCON[15]) = 1 will maintain WR = 0, and instead, set WRERR (NVMCON[13]) = 1. All Enhanced ICSP erase and programming commands will have no effect with self-checked programming commands returning a FAIL response opcode (PASS if the destination already exactly matched the requested programming data).

Once ICSP Write Inhibit is activated, it is not possible for a device executing in Debug mode to erase/write Flash, nor can a debug tool switch the device to Production mode. ICSP Write Inhibit should therefore only be activated on devices programmed for production.

### 5.4.1 ACTIVATING ICSP™ WRITE INHIBIT

**Caution:** It is not possible to deactivate ICSP Write Inhibit.

ICSP Write Inhibit is activated by executing a pair of NVMCON double-word programming commands to save two 16-bit activation values in the configuration memory space. The target NVM addresses and values required for activation are shown in Table 5-1. Once both addresses contain their activation values, ICSP Write Inhibit will take permanent effect on the next device Reset. Neither address can be reset, erased or otherwise modified, through any means, after being successfully programmed, even if one of the addresses has not been programmed.

Only the lower 16 data bits stored at the activation addresses are evaluated; the upper 8 bits and second 24-bit word written by the double-word programming (NVMOP[3:0]) should be written as '0's. The addresses can be programmed in any order and also during separate ICSP/Enhanced ICSP/RTSP sessions, but any attempt to program an incorrect 16-bit value or use a row programming operation to program the values will be aborted without altering the existing data.

**TABLE 5-1: ICSP™ WRITE INHIBIT ACTIVATION ADDRESSES AND DATA**

	Configuration Memory Address	ICSP™ Write Inhibit Activation Value
Write Lock 1	0x801034	0x006D63
Write Lock 2	0x801038	0x006870

# dsPIC33CK256MP508 FAMILY

## 5.5 Dual Partition Flash Configuration

For dsPIC33CK256MP508 devices operating in Dual Partition Flash Program Memory modes, the Inactive Partition can be erased and programmed without stalling the processor. The same programming algorithms are used for programming and erasing the Flash in the Inactive Partition, as described in [Section 5.2 “RTSP Operation”](#). On top of the page erase option, the entire Flash memory of the Inactive Partition can be erased by configuring the NVMOP[3:0] bits in the NVMCON register.

**Note 1:** The application software to be loaded into the Inactive Partition will have the address of the Active Partition. The bootloader firmware will need to offset the address by 0x400000 in order to write to the Inactive Partition.

### 5.5.1 FLASH PARTITION SWAPPING

The Boot Sequence Number is used for determining the Active Partition at start-up and is encoded within the FBTSEQ Configuration register bits. Unlike most Configuration registers, which only utilize the lower 16 bits of the program memory, FBTSEQ is a 24-bit Configuration Word. The Boot Sequence Number (BSEQ) is a 12-bit value and is stored in FBTSEQ twice. The true value is stored in bits, FBTSEQ[11:0], and its complement is stored in bits, FBTSEQ[23:12]. At device Reset, the sequence numbers are read and the partition with the lowest sequence number becomes the Active Partition. Should a Boot Sequence Number be invalid or unprogrammed, it will be overridden to value 0x000FFF prior to analysis (i.e., the highest possible Boot Sequence Number). The Boot Sequence Numbers will then be compared and the panel with the lowest Boot Sequence Number will become the Active Partition.

If both of the Boot Sequence Numbers are equal, which will also occur if they are both invalid, the default panel (Panel 1) will be selected as the Active Boot region. Should either or both Boot Sequence Numbers read the result in an ECC DED error, an ECC DERR trap will be requested; otherwise, no notification is issued for equal Boot Sequence Numbers. See [Section 30.0 “Special Features”](#) for more information.

The `BOOTSWP` instruction provides an alternative means of swapping the Active and Inactive Partitions (soft swap) without the need for a device Reset. The `BOOTSWP` must always be followed by a `GOTO` instruction. The `BOOTSWP` instruction swaps the Active and Inactive Partitions, and the PC vectors to the location specified by the `GOTO` instruction in the newly Active Partition.

It is important to note that interrupts should temporarily be disabled while performing the soft swap sequence and that after the partition swap, all peripherals and interrupts which were enabled remain enabled. Additionally, the RAM and stack will maintain state after the switch. As a result, it is recommended that applications using soft swaps jump to a routine that will reinitialize the device in order to ensure the firmware runs as expected. The Configuration registers will have no effect during a soft swap.

For robustness of operation, in order to execute the `BOOTSWP` instruction, it is necessary to execute the NVM unlocking sequence as follows:

1. Write 0x55 to NVMKEY.
2. Write 0xAA to NVMKEY.
3. Execute the `BOOTSWP` instruction.

If the unlocking sequence is not performed, the `BOOTSWP` instruction will be executed as a forced `NOP` and a `GOTO` instruction, following the `BOOTSWP` instruction, will be executed, causing the PC to jump to that location in the current operating partition.

The `SFTSWP` and `P2ACTIV` bits in the NVMCON register are used to determine a successful swap of the Active and Inactive Partitions, as well as which partition is active. After the `BOOTSWP` and `GOTO` instructions, the `SFTSWP` bit should be polled to verify the partition swap has occurred and then cleared for the next panel swap event.

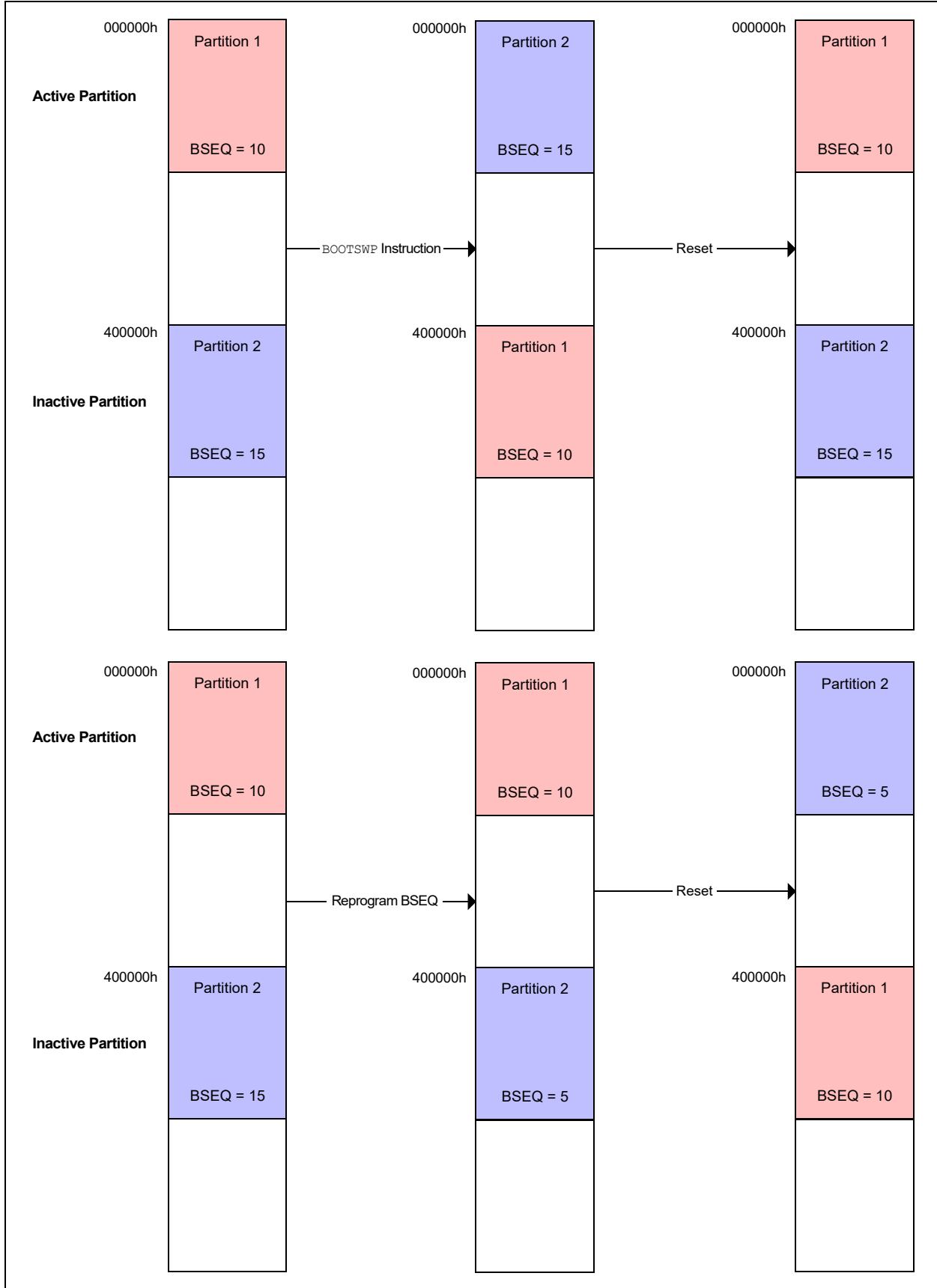
### 5.5.2 DUAL PARTITION MODES

While operating in Dual Partition mode, the dsPIC33CK256MP508 family devices have the option for both partitions to have their own defined security segments, as shown in [Figure 30-4](#). Alternatively, the device can operate in Protected Dual Partition mode, where Partition 1 becomes permanently erase/write-protected. Protected Dual Partition mode allows for a “Factory Default” mode, which provides a fail-safe backup image to be stored in Partition 1.

dsPIC33CK256MP508 family devices can also operate in Privileged Dual Partition mode, where additional security protections are implemented to allow for protection of intellectual property when multiple parties have software within the device. In Privileged Dual Partition mode, both partitions place additional restrictions on the `FBSLIM` register. These prevent changes to the size of the Boot Segment and General Segment, ensuring that neither segment will be altered.

# dsPIC33CK256MP508 FAMILY

**FIGURE 5-3: RELATIONSHIP BETWEEN PARTITIONS 1/2 AND ACTIVE/INACTIVE PARTITIONS**



# dsPIC33CK256MP508 FAMILY

---

## 5.5.3 PROGRAM FLASH MEMORY CONTROL REGISTERS

Five SFRs are used to write and erase the Program Flash Memory: NVMCON, NVMKEY, NVMADR, NVMADRU and NVMSRCADRL/H.

The NVMCON register ([Register 5-1](#)) selects the operation to be performed (page erase, word/row program, Inactive Partition erase) and initiates the program or erase cycle.

NVMKEY ([Register 5-4](#)) is a write-only register that is used for write protection. To start a programming or erase sequence, the user application must consecutively write 0x55 and 0xAA to the NVMKEY register.

There are two NVM Address registers: NVMADRU and NVMADR. These two registers, when concatenated, form the 24-bit Effective Address (EA) of the selected word/row for programming operations, or the selected page for erase operations. The NVMADRU register is used to hold the upper eight bits of the EA, while the NVMADR register is used to hold the lower 16 bits of the EA.

For row programming operation, data to be written to Program Flash Memory are written into data memory space (RAM) at an address defined by the NVMSRCADRL/H register (location of first element in row programming data).



# dsPIC33CK256MP508 FAMILY

## REGISTER 5-1: NVMCON: NONVOLATILE MEMORY (NVM) CONTROL REGISTER

R/SO-0 <sup>(1)</sup>	R/W-0 <sup>(1)</sup>	R/C-0 <sup>(1)</sup>	R/W-0	R/C-0	R-0	R/W-0	R/C-0
WR	WREN	WRERR	NVMSIDL <sup>(2)</sup>	SFTSWP	P2ACTIV	RPDF	URERR
bit 15						bit 8	

U-0	U-0	U-0	U-0	R/W-0 <sup>(1)</sup>	R/W-0 <sup>(1)</sup>	R/W-0 <sup>(1)</sup>	R/W-0 <sup>(1)</sup>
—	—	—	—	NVMOP3 <sup>(3,4)</sup>	NVMOP2 <sup>(3,4)</sup>	NVMOP1 <sup>(3,4)</sup>	NVMOP0 <sup>(3,4)</sup>
bit 7						bit 0	

<b>Legend:</b>	C = Clearable bit	SO = Settable Only bit
R = Readable bit	W = Writable bit	U = Unimplemented bit, read as '0'
-n = Value at POR	'1' = Bit is set	'0' = Bit is cleared
		x = Bit is unknown

- bit 15      **WR:** Write Control bit<sup>(1)</sup>  
 1 = Initiates a Flash memory program or erase operation; the operation is self-timed and the bit is cleared by hardware once the operation is complete  
 0 = Program or erase operation is complete and inactive
- bit 14      **WREN:** Write Enable bit<sup>(1)</sup>  
 1 = Enables Flash program/erase operations  
 0 = Inhibits Flash program/erase operations
- bit 13      **WRERR:** Write Sequence Error Flag bit<sup>(1)</sup>  
 1 = An improper program or erase sequence attempt, or termination has occurred (bit is set automatically on any set attempt of the WR bit)  
 0 = The program or erase operation completed normally
- bit 12      **NVMSIDL:** NVM Stop in Idle Control bit<sup>(2)</sup>  
 1 = Flash voltage regulator goes into Standby mode during Idle mode  
 0 = Flash voltage regulator is active during Idle mode
- bit 11      **SFTSWP:** Partition Soft Swap Status bit  
 1 = Partitions have been successfully swapped using the `BOOTSWP` instruction (soft swap)  
 0 = Awaiting successful partition swap using the `BOOTSWP` instruction or a device Reset will determine the Active Partition based on the `FBTSEQ` register
- bit 10      **P2ACTIV:** Partition 2 Active Status bit  
 1 = Partition 2 Flash is mapped into the active region  
 0 = Partition 1 Flash is mapped into the active region
- bit 9        **RPDF:** Row Programming Data Format bit  
 1 = Row data to be stored in RAM are in compressed format  
 0 = Row data to be stored in RAM are in uncompressed format
- bit 8        **URERR:** Row Programming Data Underrun Error bit  
 1 = Indicates row programming operation has been terminated  
 0 = No data underrun error is detected
- bit 7-4      **Unimplemented:** Read as '0'

- Note 1:** These bits can only be reset on a POR.
- 2:** If this bit is set, there will be minimal power savings (`IDLE`), and upon exiting Idle mode, there is a delay (`TVREG`) before Flash memory becomes operational.
- 3:** All other combinations of `NVMOP[3:0]` are unimplemented.
- 4:** Execution of the `PWRSVAV` instruction is ignored while any of the NVM operations are in progress.
- 5:** Two adjacent words on a 4-word boundary are programmed during execution of this operation.

# dsPIC33CK256MP508 FAMILY

---

## REGISTER 5-1: NVMCON: NONVOLATILE MEMORY (NVM) CONTROL REGISTER (CONTINUED)

bit 3-0      **NVMOP[3:0]:** NVM Operation Select bits<sup>(1,3,4)</sup>

- 1111 = Reserved
- 1110 = User memory bulk erase operation
- 1101 = Reserved
- 1100 = Reserved
- 1011 = Reserved
- 1010 = Reserved
- 1001 = Reserved
- 1000 = Boot mode (FBOOT) double-word program operation
- 0111 = Reserved
- 0101 = Reserved
- 0100 = Inactive Partition memory erase operation
- 0011 = Memory page erase operation
- 0010 = Memory row program operation
- 0001 = Memory double-word operation<sup>(5)</sup>
- 0000 = Reserved

- Note 1:** These bits can only be reset on a POR.
- 2:** If this bit is set, there will be minimal power savings (IDLE), and upon exiting Idle mode, there is a delay (TVREG) before Flash memory becomes operational.
- 3:** All other combinations of NVMOP[3:0] are unimplemented.
- 4:** Execution of the `PWRSVAV` instruction is ignored while any of the NVM operations are in progress.
- 5:** Two adjacent words on a 4-word boundary are programmed during execution of this operation.

# dsPIC33CK256MP508 FAMILY

## REGISTER 5-2: NVMADR: NONVOLATILE MEMORY LOWER ADDRESS REGISTER

R/W-x	R/W-x	R/W-x	R/W-x	R/W-x	R/W-x	R/W-x	R/W-x	
NVMADR[15:8]								
bit 15								bit 8

R/W-x	R/W-x	R/W-x	R/W-x	R/W-x	R/W-x	R/W-x	R/W-x	
NVMADR[7:0]								
bit 7								bit 0

<b>Legend:</b>			
R = Readable bit	W = Writable bit	U = Unimplemented bit, read as '0'	
-n = Value at POR	'1' = Bit is set	'0' = Bit is cleared	x = Bit is unknown

bit 15-0      **NVMADR[15:0]:** Nonvolatile Memory Lower Write Address bits  
 Selects the lower 16 bits of the location to program or erase in Program Flash Memory. This register may be read or written to by the user application.

## REGISTER 5-3: NVMADRU: NONVOLATILE MEMORY UPPER ADDRESS REGISTER

U-0	U-0	U-0	U-0	U-0	U-0	U-0	U-0	
—								
bit 15								bit 8

R/W-x	R/W-x	R/W-x	R/W-x	R/W-x	R/W-x	R/W-x	R/W-x	
NVMADRU[23:16]								
bit 7								bit 0

<b>Legend:</b>			
R = Readable bit	W = Writable bit	U = Unimplemented bit, read as '0'	
-n = Value at POR	'1' = Bit is set	'0' = Bit is cleared	x = Bit is unknown

bit 15-8      **Unimplemented:** Read as '0'  
 bit 7-0      **NVMADRU[23:16]:** Nonvolatile Memory Upper Write Address bits  
 Selects the upper eight bits of the location to program or erase in Program Flash Memory. This register may be read or written to by the user application.

# dsPIC33CK256MP508 FAMILY

---

## REGISTER 5-4: NVMKEY: NONVOLATILE MEMORY KEY REGISTER

U-0	U-0	U-0	U-0	U-0	U-0	U-0	U-0
—	—	—	—	—	—	—	—
bit 15							bit 8

W-0	W-0	W-0	W-0	W-0	W-0	W-0	W-0
NVMKEY[7:0]							
bit 7							bit 0

**Legend:**

R = Readable bit                      W = Writable bit                      U = Unimplemented bit, read as '0'  
 -n = Value at POR                      '1' = Bit is set                      '0' = Bit is cleared                      x = Bit is unknown

bit 15-8                      **Unimplemented:** Read as '0'  
 bit 7-0                      **NVMKEY[7:0]:** NVM Key Register bits (write-only)

# dsPIC33CK256MP508 FAMILY

## REGISTER 5-5: NVMSRCADRL: NVM SOURCE DATA ADDRESS REGISTER LOW

R/W-0	R/W-0	R/W-0	R/W-0	R/W-0	R/W-0	R/W-0	R/W-0
NVMSRCADR[15:8]							
bit 15							
bit 8							

R/W-0	R/W-0	R/W-0	R/W-0	R/W-0	R/W-0	R/W-0	R/W-0
NVMSRCADR[7:0]							
bit 7							
bit 0							

<b>Legend:</b>							
R = Readable bit	W = Writable bit	U = Unimplemented bit, read as '0'					
-n = Value at POR	'1' = Bit is set	'0' = Bit is cleared	x = Bit is unknown				

bit 15-0 **NVMSRCADR[15:0]:** NVM Source Data Address bits  
 The RAM address of the data to be programmed into Flash when the NVMOP[3:0] bits are set to row programming.

## REGISTER 5-6: NVMSRCADRH: NVM SOURCE DATA ADDRESS REGISTER HIGH

U-0	U-0	U-0	U-0	U-0	U-0	U-0	U-0
—	—	—	—	—	—	—	—
bit 15							
bit 8							

R/W-0	R/W-0	R/W-0	R/W-0	R/W-0	R/W-0	R/W-0	R/W-0
NVMSRCADR[23:16]							
bit 7							
bit 0							

<b>Legend:</b>							
R = Readable bit	W = Writable bit	U = Unimplemented bit, read as '0'					
-n = Value at POR	'1' = Bit is set	'0' = Bit is cleared	x = Bit is unknown				

bit 15-8 **Unimplemented:** Read as '0'  
 bit 7-0 **NVMSRCADR[23:16]:** NVM Source Data Address bits  
 The RAM address of the data to be programmed into Flash when the NVMOP[3:0] bits are set to row programming.

# dsPIC33CK256MP508 FAMILY

## 5.5.4 ECC CONTROL REGISTERS

### REGISTER 5-7: ECCCONL: ECC FAULT INJECTION CONFIGURATION REGISTER LOW

U-0	U-0	U-0	U-0	U-0	U-0	U-0	U-0
—	—	—	—	—	—	—	—
bit 15							bit 8

U-0	U-0	U-0	U-0	U-0	U-0	U-0	R/W-0
—	—	—	—	—	—	—	FLTINJ
bit 7							bit 0

**Legend:**

R = Readable bit                      W = Writable bit                      U = Unimplemented bit, read as '0'  
 -n = Value at POR                      '1' = Bit is set                      '0' = Bit is cleared                      x = Bit is unknown

bit 15-1                      **Unimplemented:** Read as '0'  
 bit 0                      **FLTINJ:** Fault Injection Sequence Enable bit  
                                     1 = Enabled  
                                     0 = Disabled

### REGISTER 5-8: ECCCONH: ECC FAULT INJECTION CONFIGURATION REGISTER HIGH

R/W-0	R/W-0	R/W-0	R/W-0	R/W-0	R/W-0	R/W-0	R/W-0
FLT2PTR[7:0]							
bit 15							bit 8

R/W-0	R/W-0	R/W-0	R/W-0	R/W-0	R/W-0	R/W-0	R/W-0
FLT1PTR[7:0]							
bit 7							bit 0

**Legend:**

R = Readable bit                      W = Writable bit                      U = Unimplemented bit, read as '0'  
 -n = Value at POR                      '1' = Bit is set                      '0' = Bit is cleared                      x = Bit is unknown

bit 15-8                      **FLT2PTR[7:0]:** ECC Fault Injection Bit Pointer 2 bits  
                                     11111111-00111000 = No Fault injection occurs  
                                     00110111 = Fault injection (bit inversion) occurs on bit 55 of ECC bit order  
                                     •  
                                     •  
                                     •  
                                     00000001 = Fault injection (bit inversion) occurs on bit 1 of ECC bit order  
                                     00000000 = Fault injection (bit inversion) occurs on bit 0 of ECC bit order

bit 0                      **FLT1PTR[7:0]:** ECC Fault Injection Bit Pointer 1 bits  
                                     11111111-00111000 = No Fault injection occurs  
                                     00110111 = Fault injection occurs on bit 55 of ECC bit order  
                                     •  
                                     •  
                                     •  
                                     00000001 = Fault injection occurs on bit 1 of ECC bit order  
                                     00000000 = Fault injection occurs on bit 0 of ECC bit order

# dsPIC33CK256MP508 FAMILY

## REGISTER 5-9: ECCADDRL: ECC FAULT INJECT ADDRESS COMPARE REGISTER LOW

R/W-0	R/W-0	R/W-0	R/W-0	R/W-0	R/W-0	R/W-0	R/W-0
ECCADDR[15:8]							
bit 15							bit 8

R/W-0	R/W-0	R/W-0	R/W-0	R/W-0	R/W-0	R/W-0	R/W-0
ECCADDR[7:0]							
bit 7							bit 0

<b>Legend:</b>							
R = Readable bit	W = Writable bit	U = Unimplemented bit, read as '0'					
-n = Value at POR	'1' = Bit is set	'0' = Bit is cleared	x = Bit is unknown				

bit 15-0      **ECCADDR[15:0]:** ECC Fault Injection NVM Address Match Compare bits

## REGISTER 5-10: ECCADDRH: ECC FAULT INJECT ADDRESS COMPARE REGISTER HIGH

U-0	U-0	U-0	U-0	U-0	U-0	U-0	U-0
—	—	—	—	—	—	—	—
bit 15							bit 8

R/W-0	R/W-0	R/W-0	R/W-0	R/W-0	R/W-0	R/W-0	R/W-0
ECCADDR[23:16]							
bit 7							bit 0

<b>Legend:</b>							
R = Readable bit	W = Writable bit	U = Unimplemented bit, read as '0'					
-n = Value at POR	'1' = Bit is set	'0' = Bit is cleared	x = Bit is unknown				

bit 15-8      **Unimplemented:** Read as '0'  
bit 7-0      **ECCADDR[23:16]:** ECC Fault Injection NVM Address Match Compare bits

# dsPIC33CK256MP508 FAMILY

## REGISTER 5-11: ECCSTATL: ECC SYSTEM STATUS DISPLAY REGISTER LOW

R-0	R-0	R-0	R-0	R-0	R-0	R-0	R-0
SECOUT[7:0]							
bit 15							bit 8

R-0	R-0	R-0	R-0	R-0	R-0	R-0	R-0
SECIN[7:0]							
bit 7							bit 0

**Legend:**

R = Readable bit	W = Writable bit	U = Unimplemented bit, read as '0'
-n = Value at POR	'1' = Bit is set	'0' = Bit is cleared
		x = Bit is unknown

bit 15-8      **SECOUT[7:0]:** Calculated Single Error Correction Parity Value bits  
bit 7-0        **SECIN[7:0]:** Read Single Error Correction Parity Value bits  
SECIN[7:0] bits are the actual parity value of a Flash read operation.

## REGISTER 5-12: ECCSTATH: ECC SYSTEM STATUS DISPLAY REGISTER HIGH

U-0	U-0	U-0	U-0	U-0	U-0	R-0	R-0
—	—	—	—	—	—	DEDOUT	DEDIN
bit 15							bit 8

R-0	R-0	R-0	R-0	R-0	R-0	R-0	R-0
SECSYND[7:0]							
bit 7							bit 0

**Legend:**

R = Readable bit	W = Writable bit	U = Unimplemented bit, read as '0'
-n = Value at POR	'1' = Bit is set	'0' = Bit is cleared
		x = Bit is unknown

bit 15-10    **Unimplemented:** Read as '0'  
bit 9         **DEDOUT:** Calculated Dual Bit Error Detection Parity bit  
bit 8         **DEDIN:** Read Dual Bit Error Detection Parity bit  
DEDIN is the actual parity value of a Flash read operation.  
bit 7-0       **SECSYND[7:0]:** Calculated ECC Syndrome Value bits  
Indicates the bit location that contains the error.



# dsPIC33CK256MP508 FAMILY

## 6.0 RESETS

**Note 1:** This data sheet summarizes the features of the dsPIC33CK256MP508 family of devices. It is not intended to be a comprehensive reference source. To complement the information in this data sheet, refer to “Reset” ([www.microchip.com/DS70602](http://www.microchip.com/DS70602)) in the “dsPIC33/PIC24 Family Reference Manual”.

**2:** Some registers and associated bits described in this section may not be available on all devices.

The Reset module combines all Reset sources and controls the device Master Reset Signal,  $\overline{\text{SYSRST}}$ . The following is a list of device Reset sources:

- POR: Power-on Reset
- BOR: Brown-out Reset
- MCLR: Master Clear Pin Reset
- SWR: RESET Instruction
- WDTO: Watchdog Timer Time-out Reset
- CM: Configuration Mismatch Reset
- TRAPR: Trap Conflict Reset
- IOPUWR: Illegal Condition Device Reset
  - Illegal Opcode Reset
  - Uninitialized W Register Reset
  - Security Reset

A simplified block diagram of the Reset module is shown in Figure 6-1.

Any active source of Reset will make the  $\overline{\text{SYSRST}}$  signal active. On system Reset, some of the registers associated with the CPU and peripherals are forced to a known Reset state, and some are unaffected.

**Note:** Refer to the specific peripheral section or Section 4.0 “Memory Organization” of this data sheet for register Reset states.

All types of device Reset set a corresponding status bit in the RCON register to indicate the type of Reset (see Register 6-1).

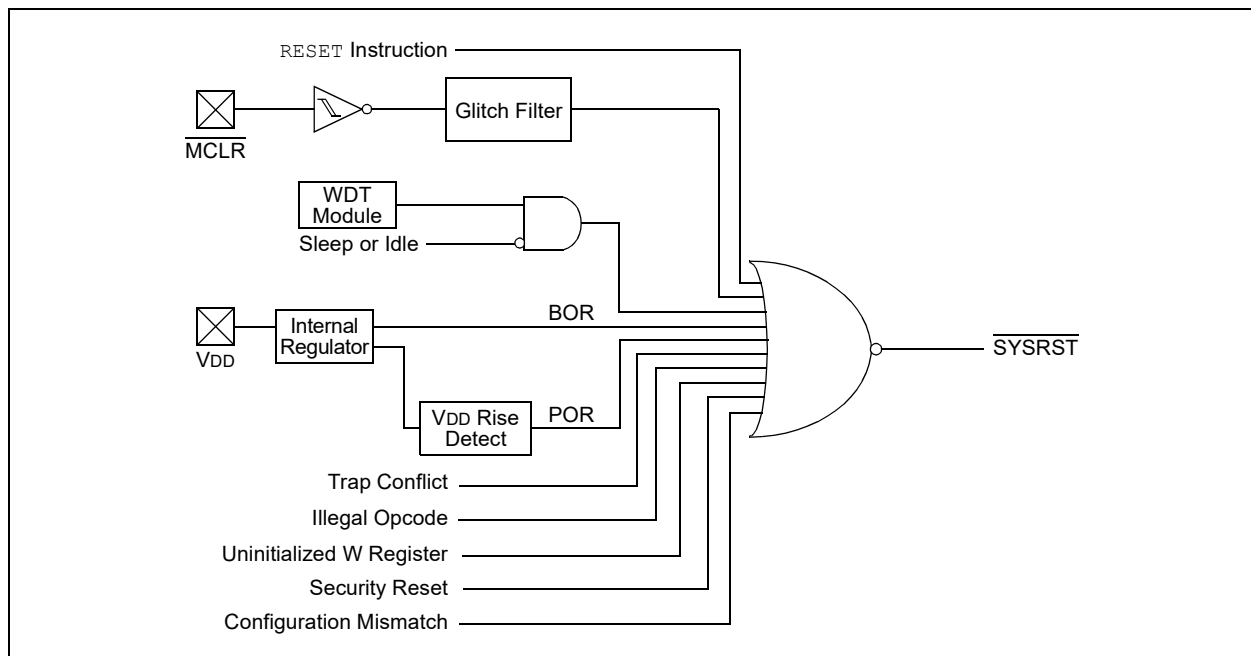
A POR clears all the bits, except for the BOR and POR bits (RCON[1:0]) that are set. The user application can set or clear any bit, at any time, during code execution. The RCON bits only serve as status bits. Setting a particular Reset status bit in software does not cause a device Reset to occur.

The RCON register also has other bits associated with the Watchdog Timer and device power-saving states. The function of these bits is discussed in other sections of this data sheet.

**Note:** The status bits in the RCON register should be cleared after they are read so that the next RCON register value after a device Reset is meaningful.

For all Resets, the default clock source is determined by the FNOSC[2:0] bits in the FOSCSEL Configuration register. The value of the FNOSCx bits is loaded into the NOSC[2:0] (OSCCON[10:8]) bits on Reset, which in turn, initializes the system clock.

**FIGURE 6-1: RESET SYSTEM BLOCK DIAGRAM**



# dsPIC33CK256MP508 FAMILY

---

## 6.1 Reset Resources

Many useful resources are provided on the main product page of the Microchip website for the devices listed in this data sheet. This product page contains the latest updates and additional information.

### 6.1.1 KEY RESOURCES

- **“Reset”** (DS70602) in the *“dsPIC33/PIC24 Family Reference Manual”*
- Code Samples
- Application Notes
- Software Libraries
- Webinars
- All Related *“dsPIC33/PIC24 Family Reference Manual”* Sections
- Development Tools

# dsPIC33CK256MP508 FAMILY

## REGISTER 6-1: RCON: RESET CONTROL REGISTER<sup>(1)</sup>

R/W-0	R/W-0	U-0	U-0	U-0	U-0	R/W-0	R/W-0
TRAPR	IOPUWR	—	—	—	—	CM	VREGS
bit 15						bit 8	

R/W-1	R/W-0	r-0	R/W-0	R/W-0	R/W-0	R/W-1	R/W-1
EXTR	SWR	—	WDTO	SLEEP	IDLE	BOR	POR
bit 7						bit 0	

<b>Legend:</b>	r = Reserved bit
R = Readable bit	W = Writable bit
-n = Value at POR	'1' = Bit is set
	U = Unimplemented bit, read as '0'
	'0' = Bit is cleared
	x = Bit is unknown

- bit 15      **TRAPR:** Trap Reset Flag bit  
 1 = A Trap Conflict Reset has occurred  
 0 = A Trap Conflict Reset has not occurred
- bit 14      **IOPUWR:** Illegal Opcode or Uninitialized W Register Access Reset Flag bit  
 1 = An illegal opcode detection, an illegal address mode or Uninitialized W register used as an Address Pointer caused a Reset  
 0 = An illegal opcode or Uninitialized W Register Reset has not occurred
- bit 13-10   **Unimplemented:** Read as '0'
- bit 9        **CM:** Configuration Mismatch Flag bit  
 1 = A Configuration Mismatch Reset has occurred.  
 0 = A Configuration Mismatch Reset has not occurred
- bit 8        **VREGS:** Voltage Regulator Standby During Sleep bit  
 1 = Voltage regulator is active during Sleep  
 0 = Voltage regulator goes into Standby mode during Sleep
- bit 7        **EXTR:** External Reset ( $\overline{\text{MCLR}}$ ) Pin bit  
 1 = A Master Clear (pin) Reset has occurred  
 0 = A Master Clear (pin) Reset has not occurred
- bit 6        **SWR:** Software RESET (Instruction) Flag bit  
 1 = A RESET instruction has been executed  
 0 = A RESET instruction has not been executed
- bit 5        **Reserved:** Read as '0'
- bit 4        **WDTO:** Watchdog Timer Time-out Flag bit  
 1 = WDT time-out has occurred  
 0 = WDT time-out has not occurred
- bit 3        **SLEEP:** Wake-up from Sleep Flag bit  
 1 = Device has been in Sleep mode  
 0 = Device has not been in Sleep mode
- bit 2        **IDLE:** Wake-up from Idle Flag bit  
 1 = Device has been in Idle mode  
 0 = Device has not been in Idle mode
- bit 1        **BOR:** Brown-out Reset Flag bit  
 1 = A Brown-out Reset has occurred  
 0 = A Brown-out Reset has not occurred
- bit 0        **POR:** Power-on Reset Flag bit  
 1 = A Power-on Reset has occurred  
 0 = A Power-on Reset has not occurred

**Note 1:** All of the Reset status bits can be set or cleared in software. Setting one of these bits in software does not cause a device Reset.

# dsPIC33CK256MP508 FAMILY

---

---

NOTES:

## 7.0 INTERRUPT CONTROLLER

**Note 1:** This data sheet summarizes the features of the dsPIC33CK256MP508 family of devices. It is not intended to be a comprehensive reference source. To complement the information in this data sheet, refer to “**Interrupts**” ([www.microchip.com/DS70000600](http://www.microchip.com/DS70000600)) in the “*dsPIC33/PIC24 Family Reference Manual*”.

**2:** Some registers and associated bits described in this section may not be available on all devices.

The dsPIC33CK256MP508 family interrupt controller reduces the numerous peripheral interrupt request signals to a single interrupt request signal to the dsPIC33CK256MP508 family CPU.

The interrupt controller has the following features:

- Six Processor Exceptions and Software Traps
- Seven User-Selectable Priority Levels
- Interrupt Vector Table (IVT) with a Unique Vector for each Interrupt or Exception Source
- Fixed Priority within a Specified User Priority Level
- Fixed Interrupt Entry and Return Latencies
- Alternate Interrupt Vector Table (AIVT) for Debug Support

### 7.1 Interrupt Vector Table

The dsPIC33CK256MP508 family Interrupt Vector Table (IVT), shown in [Figure 7-1](#), resides in program memory, starting at location, 000004h. The IVT contains six non-maskable trap vectors and up to 246 sources of interrupts. In general, each interrupt source has its own vector. Each interrupt vector contains a 24-bit wide address. The value programmed into each interrupt vector location is the starting address of the associated Interrupt Service Routine (ISR).

Interrupt vectors are prioritized in terms of their natural priority. This priority is linked to their position in the vector table. Lower addresses generally have a higher natural priority. For example, the interrupt associated with Vector 0 takes priority over interrupts at any other vector address.

### 7.1.1 ALTERNATE INTERRUPT VECTOR TABLE

The Alternate Interrupt Vector Table (AIVT), shown in [Figure 7-2](#), is available only when the Boot Segment (BS) is defined and the AIVT has been enabled. To enable the Alternate Interrupt Vector Table, the Configuration bit, AIVTDIS in the FSEC register, must be programmed and the AIVTEN bit must be set (INTCON2[8] = 1). When the AIVT is enabled, all interrupt and exception processes use the alternate vectors instead of the default vectors. The AIVT begins at the start of the last page of the Boot Segment, defined by BSLIM[12:0]. The second half of the page is no longer usable space. The Boot Segment must be at least two pages to enable the AIVT.

**Note:** Although the Boot Segment must be enabled in order to enable the AIVT, application code does not need to be present inside of the Boot Segment. The AIVT (and IVT) will inherit the Boot Segment code protection.

The AIVT supports debugging by providing a means to switch between an application and a support environment without requiring the interrupt vectors to be reprogrammed. This feature also enables switching between applications for evaluation of different software algorithms at run time.

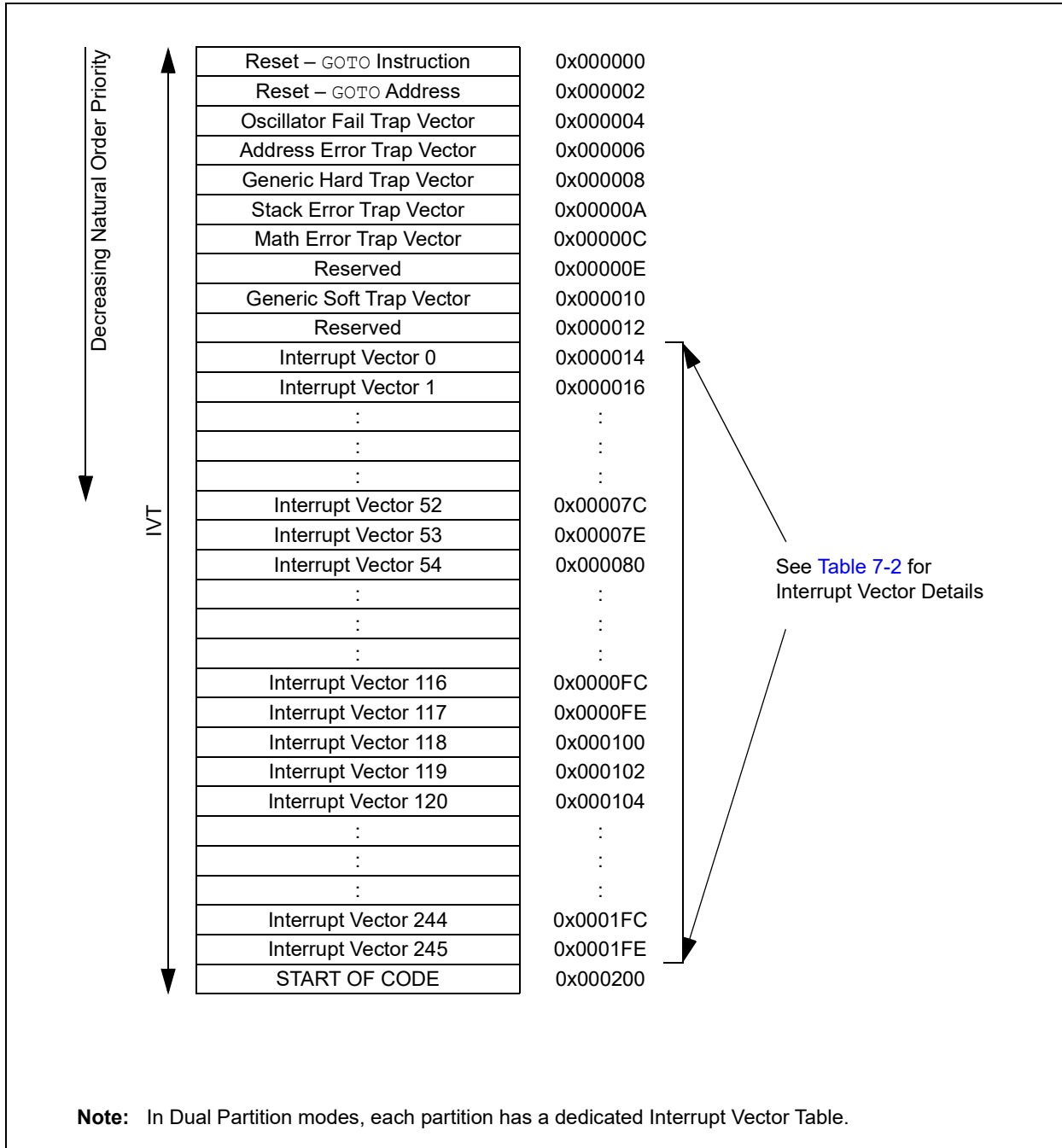
### 7.2 Reset Sequence

A device Reset is not a true exception because the interrupt controller is not involved in the Reset process. The dsPIC33CK256MP508 family devices clear their registers in response to a Reset, which forces the PC to zero. The device then begins program execution at location, 0x000000. A GOTO instruction at the Reset address can redirect program execution to the appropriate start-up routine.

**Note:** Any unimplemented or unused vector locations in the IVT should be programmed with the address of a default interrupt handler routine that contains a RESET instruction.

# dsPIC33CK256MP508 FAMILY

**FIGURE 7-1: dsPIC33CK256MP508 FAMILY INTERRUPT VECTOR TABLE**



# dsPIC33CK256MP508 FAMILY

**FIGURE 7-2: dsPIC33CK256MP508 ALTERNATE INTERRUPT VECTOR TABLE<sup>(2)</sup>**

↓ Decreasing Natural Order Priority  AIVT  ↓	Reserved	$\text{BSLIM}[12:0]^{(1)} + 0x000000$	See <a href="#">Table 7-2</a> for Interrupt Vector Details
	Reserved	$\text{BSLIM}[12:0]^{(1)} + 0x000002$	
	Oscillator Fail Trap Vector	$\text{BSLIM}[12:0]^{(1)} + 0x000004$	
	Address Error Trap Vector	$\text{BSLIM}[12:0]^{(1)} + 0x000006$	
	Generic Hard Trap Vector	$\text{BSLIM}[12:0]^{(1)} + 0x000008$	
	Stack Error Trap Vector	$\text{BSLIM}[12:0]^{(1)} + 0x00000A$	
	Math Error Trap Vector	$\text{BSLIM}[12:0]^{(1)} + 0x00000C$	
	Reserved	$\text{BSLIM}[12:0]^{(1)} + 0x00000E$	
	Generic Soft Trap Vector	$\text{BSLIM}[12:0]^{(1)} + 0x000010$	
	Reserved	$\text{BSLIM}[12:0]^{(1)} + 0x000012$	
	Interrupt Vector 0	$\text{BSLIM}[12:0]^{(1)} + 0x000014$	
	Interrupt Vector 1	$\text{BSLIM}[12:0]^{(1)} + 0x000016$	
	:	:	
	:	:	
	:	:	
	Interrupt Vector 52	$\text{BSLIM}[12:0]^{(1)} + 0x00007C$	
	Interrupt Vector 53	$\text{BSLIM}[12:0]^{(1)} + 0x00007E$	
	Interrupt Vector 54	$\text{BSLIM}[12:0]^{(1)} + 0x000080$	
	:	:	
	:	:	
	:	:	
	Interrupt Vector 116	$\text{BSLIM}[12:0]^{(1)} + 0x0000FC$	
	Interrupt Vector 117	$\text{BSLIM}[12:0]^{(1)} + 0x0000FE$	
	Interrupt Vector 118	$\text{BSLIM}[12:0]^{(1)} + 0x000100$	
	Interrupt Vector 119	$\text{BSLIM}[12:0]^{(1)} + 0x000102$	
Interrupt Vector 120	$\text{BSLIM}[12:0]^{(1)} + 0x000104$		
:	:		
:	:		
:	:		
Interrupt Vector 244	$\text{BSLIM}[12:0]^{(1)} + 0x0001FC$		
Interrupt Vector 245	$\text{BSLIM}[12:0]^{(1)} + 0x0001FE$		

- Note 1:** The address depends on the size of the Boot Segment defined by BSLIM[12:0]:  
 $[(\text{BSLIM}[12:0] - 1) \times 0x800] + \text{Offset}$ .
- 2:** In Dual Partition modes, each partition has a dedicated Alternate Interrupt Vector Table (if enabled).

# dsPIC33CK256MP508 FAMILY

**TABLE 7-1: TRAP VECTOR DETAILS**

Trap Description	MPLAB® XC16 Trap ISR Name	Vector #	IVT Address	Trap Bit Location			Priority
				Interrupt Flag	Type	Enable	
Oscillator Failure	_OscillatorFail	0	0x000004	INTCON1[1]	—	—	15
Address Error	_AddressError	1	0x000006	INTCON1[3]	—	—	14
ECC Double-Bit Error	_HardTrapError	2	0x000008	INTCON4[1]	—	—	13
Software Generated Trap	_HardTrapError	2	0x000008	INTCON4[0]	—	INTCON2[13]	13
Stack Error	_StackError	3	0x00000A	INTCON1[2]	—	—	12
Overflow Accumulator A	_MathError	4	0x00000C	INTCON1[4]	INTCON1[14]	INTCON1[10]	11
Overflow Accumulator B	_MathError	4	0x00000C	INTCON1[4]	INTCON1[13]	INTCON1[9]	11
Catastrophic Overflow Accumulator A	_MathError	4	0x00000C	INTCON1[4]	INTCON1[12]	INTCON1[8]	11
Catastrophic Overflow Accumulator B	_MathError	4	0x00000C	INTCON1[4]	INTCON1[11]	INTCON1[8]	11
Shift Accumulator Error	_MathError	4	0x00000C	INTCON1[4]	INTCON1[7]	INTCON1[8]	11
Divide-by-Zero Error	_MathError	4	0x00000C	INTCON1[4]	INTCON1[6]	INTCON1[8]	11
Reserved	Reserved	5	0x00000E	—	—	—	—
CAN Address Error	_SoftTrapError	6	0x000010	INTCON3[9]	—	—	9
NVM Address Error	_SoftTrapError	6	0x000010	INTCON3[8]	—	—	9
DMA Address Error	_SoftTrapError	6	0x000010	INTCON3[5]	—	—	9
DO Stack Overflow	_SoftTrapError	6	0x000010	INTCON3[4]	—	—	9
APLL Loss of Lock	_SoftTrapError	6	0x000010	INTCON3[0]	—	—	9
Reserved	Reserved	7	0x000012	—	—	—	—



# dsPIC33CK256MP508 FAMILY

**TABLE 7-2: INTERRUPT VECTOR DETAILS**

Interrupt Source	MPLAB® XC16 ISR Name	Vector #	IRQ #	IVT Address	Interrupt Bit Location		
					Flag	Enable	Priority
External Interrupt 0	_INT0Interrupt	8	0	0x000014	IFS0[0]	IEC0[0]	IPC0[2:0]
Timer1	_T1Interrupt	9	1	0x000016	IFS0[1]	IEC0[1]	IPC0[6:4]
Change Notice Interrupt A	_CNAInterrupt	10	2	0x000018	IFS0[2]	IEC0[2]	IPC0[10:8]
Change Notice Interrupt B	_CNBInterrupt	11	3	0x00001A	IFS0[3]	IEC0[3]	IPC0[14:12]
DMA Channel 0	_DMA0Interrupt	12	4	0x00001C	IFS0[4]	IEC0[4]	IPC1[2:0]
Reserved	Reserved	13	5	0x00001E	—	—	—
Input Capture/Output Compare 1	_CCP1Interrupt	14	6	0x000020	IFS0[6]	IEC0[6]	IPC1[10:8]
CCP1 Timer	_CCT1Interrupt	15	7	0x000022	IFS0[7]	IEC0[7]	IPC1[14:12]
DMA Channel 1	_DMA1Interrupt	16	8	0x000024	IFS0[8]	IEC0[8]	IPC2[2:0]
SPI1 Receiver	_SPI1RXInterrupt	17	9	0x000026	IFS0[9]	IEC0[9]	IPC2[6:4]
SPI1 Transmitter	_SPI1TXInterrupt	18	10	0x000028	IFS0[10]	IEC0[10]	IPC2[10:8]
UART1 Receiver	_U1RXInterrupt	19	11	0x00002A	IFS0[11]	IEC0[11]	IPC2[14:12]
UART1 Transmitter	_U1TXInterrupt	20	12	0x00002C	IFS0[12]	IEC0[12]	IPC3[2:0]
ECC Single-Bit Error	_ECCSBEInterrupt	21	13	0x00002E	IFS0[13]	IEC0[13]	IPC3[6:4]
NVM Write Complete	_NVMInterrupt	22	14	0x000030	IFS0[14]	IEC0[14]	IPC3[10:8]
External Interrupt 1	_INT1Interrupt	23	15	0x000032	IFS0[15]	IEC0[15]	IPC3[14:12]
I2C1 Client Event	_SI2C1Interrupt	24	16	0x000034	IFS1[0]	IEC1[0]	IPC4[2:0]
I2C1 Host Event	_MI2C1Interrupt	25	17	0x000036	IFS1[1]	IEC1[1]	IPC4[6:4]
DMA Channel 2	_DMA2Interrupt	26	18	0x000038	IFS1[2]	IEC1[2]	IPC4[10:8]
Change Notice Interrupt C <sup>(2)</sup>	_CNCInterrupt	27	19	0x00003A	IFS1[3]	IEC1[3]	IPC4[14:12]
External Interrupt 2	_INT2Interrupt	28	20	0x00003C	IFS1[4]	IEC1[4]	IPC5[2:0]
DMA Channel 3	_DMA3Interrupt	29	21	0x00003E	IFS1[5]	IEC1[5]	IPC5[6:4]
Reserved	Reserved	30	22	0x000040	—	—	—
Input Capture/Output Compare 2	_CCP2Interrupt	31	23	0x000042	IFS1[7]	IEC1[7]	IPC5[14:12]
CCP2 Timer	_CCT2Interrupt	32	24	0x000044	IFS1[8]	IEC1[8]	IPC6[2:0]
CAN1 Combined Error <sup>(3)</sup>	_CAN1Interrupt	33	25	0x000046	IFS1[9]	IEC1[9]	IPC6[6:4]
External Interrupt 3	_INT3Interrupt	34	26	0x000048	IFS1[10]	IEC1[10]	IPC6[10:8]
UART2 Receiver	_U2RXInterrupt	35	27	0x00004A	IFS1[11]	IEC1[11]	IPC6[14:12]
UART2 Transmitter	_U2TXInterrupt	36	28	0x00004C	IFS1[12]	IEC1[12]	IPC7[2:0]
SPI2 Receiver	_SPI2RXInterrupt	37	29	0x00004E	IFS1[13]	IEC1[13]	IPC7[6:4]
SPI2 Transmitter	_SPI2TXInterrupt	38	30	0x000050	IFS1[14]	IEC1[14]	IPC7[10:8]
CAN1 RX Data Ready <sup>(3)</sup>	_C1RXInterrupt	39	31	0x000052	IFS1[15]	IEC1[15]	IPC7[14:12]
Reserved	Reserved	40-42	32-34	0x000054-0x000058	—	—	—
Input Capture/Output Compare 3	_CCP3Interrupt	43	35	0x00005A	IFS2[3]	IEC2[3]	IPC8[14:12]
CCP3 Timer	_CCT3Interrupt	44	36	0x00005C	IFS2[4]	IEC2[4]	IPC9[2:0]
I2C2 Client Event	_SI2C2Interrupt	45	37	0x00005E	IFS2[5]	IEC2[5]	IPC9[6:4]
I2C2 Host Event	_MI2C2Interrupt	46	38	0x000060	IFS2[6]	IEC2[6]	IPC9[10:8]
Reserved	Reserved	47	39	0x000062	—	—	—
Input Capture/Output Compare 4	_CCP4Interrupt	48	40	0x000064	IFS2[8]	IEC2[8]	IPC10[2:0]
CCP4 Timer	_CCT4Interrupt	49	41	0x000066	IFS2[9]	IEC2[9]	IPC10[6:4]
Reserved	Reserved	50	42	0x000068	—	—	—

**Note 1:** Availability is dependent on number of supported ADC channels. Refer to [Table 1](#) and [Table 2](#) for ADC channel availability on device variants.

**2:** Availability is dependent on supported I/O ports. Refer to [Table 8-1](#) for availability on device variants.

**3:** Availability is dependent on supported peripherals. Refer to [Table 1](#) and [Table 2](#).

# dsPIC33CK256MP508 FAMILY

**TABLE 7-2: INTERRUPT VECTOR DETAILS (CONTINUED)**

Interrupt Source	MPLAB® XC16 ISR Name	Vector #	IRQ #	IVT Address	Interrupt Bit Location		
					Flag	Enable	Priority
Input Capture/Output Compare 5	_CCP5Interrupt	51	43	0x00006A	IFS2[11]	IEC2[11]	IPC10[14:12]
CCP5 Timer	_CCT5Interrupt	52	44	0x00006C	IFS2[12]	IEC2[12]	IPC11[2:0]
Deadman Timer	_DMTInterrupt	53	45	0x00006E	IFS2[13]	IEC2[13]	IPC11[6:4]
Input Capture/Output Compare 6	_CCP6Interrupt	54	46	0x000070	IFS2[14]	IEC2[14]	IPC11[10:8]
CCP6 Timer	_CCT6Interrupt	55	47	0x000072	IFS2[15]	IEC2[15]	IPC11[14:12]
QE1 Position Counter Compare	_QE1Interrupt	56	48	0x000074	IFS3[0]	IEC3[0]	IPC12[2:0]
UART1 Error	_U1EInterrupt	57	49	0x000076	IFS3[1]	IEC3[1]	IPC12[6:4]
UART2 Error	_U2EInterrupt	58	50	0x000078	IFS3[2]	IEC3[2]	IPC12[10:8]
CRC Generator	_CRCInterrupt	59	51	0x00007A	IFS3[3]	IEC3[3]	IPC12[14:12]
CAN1 TX Data Request <sup>(3)</sup>	_C1TXInterrupt	60	52	0x00007C	IFS3[4]	IEC3[4]	IPC13[2:0]
Reserved	Reserved	61	53	0x00007E	—	—	—
QE1 Position Counter Compare	_QE12Interrupt	62	54	0x000080	IFS3[6]	IEC3[6]	IPC13[10:8]
Reserved	Reserved	63	55	0x000082	—	—	—
UART3 Error	_U3EInterrupt	64	56	0x000084	IFS3[8]	IEC3[8]	IPC14[2:0]
UART3 Receiver	_U3RXInterrupt	65	57	0x000086	IFS3[9]	IEC3[9]	IPC14[6:4]
UART3 Transmitter	_U3TXInterrupt	66	58	0x000088	IFS3[10]	IEC3[10]	IPC14[10:8]
SPI3 Receiver	_SPI3RXInterrupt	67	59	0x00008A	IFS3[11]	IEC3[11]	IPC14[14:12]
SPI3 Transmitter	_SPI3TXInterrupt	68	60	0x00008C	IFS3[12]	IEC3[12]	IPC15[2:0]
In-Circuit Debugger	_ICDInterrupt	69	61	0x00008E	IFS3[13]	IEC3[13]	IPC15[6:4]
Reserved	Reserved	70	62	0x000090	—	—	—
PTG Step	_PTGSTEPInterrupt	71	63	0x000092	IFS3[15]	IEC3[15]	IPC15[14:12]
I2C1 Bus Collision	_I2C1BCInterrupt	72	64	0x000094	IFS4[0]	IEC4[0]	IPC16[2:0]
I2C2 Bus Collision	_I2C2BCInterrupt	73	65	0x000096	IFS4[1]	IEC4[1]	IPC16[6:4]
Reserved	Reserved	74	66	0x000098	—	—	—
PWM Generator 1	_PWM1Interrupt	75	67	0x00009A	IFS4[3]	IEC4[3]	IPC16[14:12]
PWM Generator 2	_PWM2Interrupt	76	68	0x00009C	IFS4[4]	IEC4[4]	IPC17[2:0]
PWM Generator 3	_PWM3Interrupt	77	69	0x00009E	IFS4[5]	IEC4[5]	IPC17[6:4]
PWM Generator 4	_PWM4Interrupt	78	70	0x0000A0	IFS4[6]	IEC4[6]	IPC17[10:8]
PWM Generator 5	_PWM5Interrupt	79	71	0x0000A2	IFS4[7]	IEC4[7]	IPC17[14:12]
PWM Generator 6	_PWM6Interrupt	80	72	0x0000A4	IFS4[8]	IEC4[8]	IPC18[2:0]
PWM Generator 7	_PWM7Interrupt	81	73	0x0000A6	IFS4[9]	IEC4[9]	IPC18[6:4]
PWM Generator 8	_PWM8Interrupt	82	74	0x0000A8	IFS4[10]	IEC4[10]	IPC18[10:8]
Change Notice D <sup>(2)</sup>	_CNDInterrupt	83	75	0x0000AA	IFS4[11]	IEC4[11]	IPC18[14:12]
Change Notice E <sup>(2)</sup>	_CNEInterrupt	84	76	0x0000AC	IFS4[12]	IEC4[12]	IPC19[2:0]
Comparator 1	_CMP1Interrupt	85	77	0x0000AE	IFS4[13]	IEC4[13]	IPC19[6:4]
Comparator 2	_CMP2Interrupt	86	78	0x0000B0	IFS4[14]	IEC4[14]	IPC19[10:8]
Comparator 3	_CMP3Interrupt	87	79	0x0000B2	IFS4[15]	IEC4[15]	IPC19[14:12]
Reserved	Reserved	88	80	0x0000B4	—	—	—
PTG Watchdog Timer Time-out	_PTGWDTInterrupt	89	81	0x0000B6	IFS5[1]	IEC5[1]	IPC20[6:4]
PTG Trigger 0	_PTG0Interrupt	90	82	0x0000B8	IFS5[2]	IEC5[2]	IPC20[10:8]
PTG Trigger 1	_PTG1Interrupt	91	83	0x0000BA	IFS5[3]	IEC5[3]	IPC20[14:12]
PTG Trigger 2	_PTG2Interrupt	92	84	0x0000BC	IFS5[4]	IEC5[4]	IPC21[2:0]
PTG Trigger 3	_PTG3Interrupt	93	85	0x0000BE	IFS5[5]	IEC5[6]	IPC21[6:4]

**Note 1:** Availability is dependent on number of supported ADC channels. Refer to [Table 1](#) and [Table 2](#) for ADC channel availability on device variants.

**2:** Availability is dependent on supported I/O ports. Refer to [Table 8-1](#) for availability on device variants.

**3:** Availability is dependent on supported peripherals. Refer to [Table 1](#) and [Table 2](#).

# dsPIC33CK256MP508 FAMILY

**TABLE 7-2: INTERRUPT VECTOR DETAILS (CONTINUED)**

Interrupt Source	MPLAB® XC16 ISR Name	Vector #	IRQ #	IVT Address	Interrupt Bit Location		
					Flag	Enable	Priority
SENT1 TX/RX	_SENT1Interrupt	94	86	0x0000C0	IFS5[6]	IEC5[6]	IPC21[10:8]
SENT1 Error	_SENT1EInterrupt	95	87	0x0000C2	IFS5[7]	IEC5[7]	IPC21[14:12]
SENT2 TX/RX	_SENT2Interrupt	96	88	0x0000C4	IFS5[8]	IEC5[8]	IPC22[2:0]
SENT2 Error	_SENT2EInterrupt	97	89	0x0000C6	IFS5[9]	IEC5[9]	IPC22[6:4]
ADC Global Interrupt	_ADCInterrupt	98	90	0x0000C8	IFS5[10]	IEC5[10]	IPC22[10:8]
ADC AN0 Interrupt	_ADCAN0Interrupt	99	91	0x0000CA	IFS5[11]	IEC5[11]	IPC22[14:12]
ADC AN1 Interrupt	_ADCAN1Interrupt	100	92	0x0000CC	IFS5[12]	IEC5[12]	IPC23[2:0]
ADC AN2 Interrupt	_ADCAN2Interrupt	101	93	0x0000CE	IFS5[13]	IEC5[13]	IPC23[6:4]
ADC AN3 Interrupt	_ADCAN3Interrupt	102	94	0x0000D0	IFS5[14]	IEC5[14]	IPC23[10:8]
ADC AN4 Interrupt	_ADCAN4Interrupt	103	95	0x0000D2	IFS5[15]	IEC5[15]	IPC23[14:12]
ADC AN5 Interrupt	_ADCAN5Interrupt	104	96	0x0000D4	IFS6[0]	IEC6[0]	IPC24[2:0]
ADC AN6 Interrupt	_ADCAN6Interrupt	105	97	0x0000D6	IFS6[1]	IEC6[1]	IPC24[6:4]
ADC AN7 Interrupt	_ADCAN7Interrupt	106	98	0x0000D8	IFS6[2]	IEC6[2]	IPC24[10:8]
ADC AN8 Interrupt	_ADCAN8Interrupt	107	99	0x0000DA	IFS6[3]	IEC6[3]	IPC24[14:12]
ADC AN9 Interrupt	_ADCAN9Interrupt	108	100	0x0000DC	IFS6[4]	IEC6[4]	IPC25[2:0]
ADC AN10 Interrupt	_ADCAN10Interrupt	109	101	0x0000DE	IFS6[5]	IEC6[5]	IPC25[6:4]
ADC AN11 Interrupt	_ADCAN11Interrupt	110	102	0x0000E0	IFS6[6]	IEC6[6]	IPC25[10:8]
ADC AN12 Interrupt <sup>(1)</sup>	_ADCAN12Interrupt	111	103	0x0000E2	IFS6[7]	IEC6[7]	IPC25[14:12]
ADC AN13 Interrupt <sup>(1)</sup>	_ADCAN13Interrupt	112	104	0x0000E4	IFS6[8]	IEC6[8]	IPC26[2:0]
ADC AN14 Interrupt <sup>(1)</sup>	_ADCAN14Interrupt	113	105	0x0000E6	IFS6[9]	IEC6[9]	IPC26[6:4]
ADC AN15 Interrupt <sup>(1)</sup>	_ADCAN15Interrupt	114	106	0x0000E8	IFS6[10]	IEC6[10]	IPC26[10:8]
ADC AN16 Interrupt <sup>(1)</sup>	_ADCAN16Interrupt	115	107	0x0000EA	IFS6[11]	IEC6[11]	IPC26[14:12]
ADC AN17 Interrupt <sup>(1)</sup>	_ADCAN17Interrupt	116	108	0x0000EC	IFS6[12]	IEC6[12]	IPC27[2:0]
ADC AN18 Interrupt <sup>(1)</sup>	_ADCAN18Interrupt	117	109	0x0000EE	IFS6[13]	IEC6[13]	IPC27[6:4]
ADC AN19 Interrupt <sup>(1)</sup>	_ADCAN19Interrupt	118	110	0x0000F0	IFS6[14]	IEC6[14]	IPC27[10:8]
ADC AN20 Interrupt <sup>(1)</sup>	_ADCAN20Interrupt	119	111	0x0000F2	IFS6[15]	IEC6[15]	IPC27[14:12]
ADC AN21 Interrupt <sup>(1)</sup>	_ADCAN21Interrupt	120	112	0x0000F4	IFS7[0]	IEC7[0]	IPC28[2:0]
ADC AN22 Interrupt <sup>(1)</sup>	_ADCAN22Interrupt	121	113	0x0000F6	IFS7[1]	IEC7[1]	IPC28[6:4]
ADC AN23 Interrupt <sup>(1)</sup>	_ADCAN23Interrupt	122	114	0x0000F8	IFS7[2]	IEC7[2]	IPC28[10:8]
ADC Fault	_ADFLTInterrupt	123	115	0x0000FA	IFS7[3]	IEC7[3]	IPC28[14:12]
ADC Digital Comparator 0	_ADCMP0Interrupt	124	116	0x0000FC	IFS7[4]	IEC7[4]	IPC29[2:0]
ADC Digital Comparator 1	_ADCMP1Interrupt	125	117	0x0000FE	IFS7[5]	IEC7[5]	IPC29[6:4]
ADC Digital Comparator 2	_ADCMP2Interrupt	126	118	0x000100	IFS7[6]	IEC7[6]	IPC29[10:8]
ADC Digital Comparator 3	_ADCMP3Interrupt	127	119	0x000102	IFS7[7]	IEC7[7]	IPC29[14:12]
ADC Oversample Filter 0	_ADFLTR0Interrupt	128	120	0x000104	IFS7[8]	IEC7[8]	IPC30[2:0]
ADC Oversample Filter 1	_ADFLTR1Interrupt	129	121	0x000106	IFS7[9]	IEC7[9]	IPC30[6:4]
ADC Oversample Filter 2	_ADFLTR2Interrupt	130	122	0x000108	IFS7[10]	IEC7[10]	IPC30[10:8]
ADC Oversample Filter 3	_ADFLTR3Interrupt	131	123	0x00010A	IFS7[11]	IEC7[11]	IPC30[14:12]
CLC1 Positive Edge	_CLC1PInterrupt	132	124	0x00010C	IFS7[12]	IEC7[12]	IPC31[2:0]
CLC2 Positive Edge	_CLC2PInterrupt	133	125	0x00010E	IFS7[13]	IEC7[13]	IPC31[6:4]
SPI1 Error	_SPI1GInterrupt	134	126	0x000110	IFS7[14]	IEC7[14]	IPC31[10:8]
SPI2 Error	_SPI2GInterrupt	135	127	0x000112	IFS7[15]	IEC7[15]	IPC31[14:12]
SPI3 Error	_SPI3GInterrupt	136	128	0x000114	IFS8[0]	IEC8[0]	IPC32[2:0]

**Note 1:** Availability is dependent on number of supported ADC channels. Refer to [Table 1](#) and [Table 2](#) for ADC channel availability on device variants.

**2:** Availability is dependent on supported I/O ports. Refer to [Table 8-1](#) for availability on device variants.

**3:** Availability is dependent on supported peripherals. Refer to [Table 1](#) and [Table 2](#).

# dsPIC33CK256MP508 FAMILY

**TABLE 7-2: INTERRUPT VECTOR DETAILS (CONTINUED)**

Interrupt Source	MPLAB® XC16 ISR Name	Vector #	IRQ #	IVT Address	Interrupt Bit Location		
					Flag	Enable	Priority
Reserved	Reserved	137-149	129-141	0x000116-0x00012E	—	—	—
I2C3 Client Event	_SI2C3Interrupt	150	142	0x000130	IFS8[14]	IEC8[14]	IPC35[10:8]
I2C3 Host Event	_MI2C3Interrupt	151	143	0x000132	IFS8[15]	IEC8[15]	IPC35[14:12]
I2C3 Bus Collision	_I2C3BCInterrupt	152	144	0x000134	IFS9[0]	IEC9[0]	IPC36[2:0]
Reserved	Reserved	153-156	145-148	0x000136-0x00013C	—	—	—
Input Capture/Output Compare 7	_CCP7Interrupt	157	149	0x00013E	IFS9[5]	IEC9[5]	IPC37[6:4]
CCP7 Timer	_CCT7Interrupt	158	150	0x000140	IFS9[6]	IEC9[6]	IPC37[10:8]
Reserved	Reserved	159	151	0x000142	—	—	—
Input Capture/Output Compare 8	_CCP8Interrupt	160	152	0x000144	IFS9[8]	IEC9[8]	IPC38[2:0]
CCP8 Timer	_CCT8Interrupt	161	153	0x000146	IFS9[9]	IEC9[9]	IPC38[6:4]
Reserved	Reserved	162-176	154-168	0x000148-0x000164	—	—	—
PWM Event A	_PEVTAInterrupt	177	169	0x000166	IFS10[9]	IEC10[9]	IPC42[6:4]
PWM Event B	_PEVTBInterrupt	178	170	0x000168	IFS10[10]	IEC10[10]	IPC42[10:8]
PWM Event C	_PEVTCInterrupt	179	171	0x00016A	IFS10[11]	IEC10[11]	IPC42[14:12]
PWM Event D	_PEVTDInterrupt	180	172	0x00016C	IFS10[12]	IEC10[12]	IPC43[2:0]
PWM Event E	_PEVTEInterrupt	181	173	0x00016E	IFS10[13]	IEC10[13]	IPC43[6:4]
PWM Event F	_PEVTFInterrupt	182	174	0x000170	IFS10[14]	IEC10[14]	IPC43[10:8]
CLC3 Positive Edge	_CLC3PInterrupt	183	175	0x000172	IFS10[15]	IEC10[15]	IPC43[14:12]
CLC4 Positive Edge	_CLC4PInterrupt	184	176	0x000174	IFS11[0]	IEC11[0]	IPC44[2:0]
CLC1 Negative Edge	_CLC1NInterrupt	185	177	0x000176	IFS11[1]	IEC11[1]	IPC44[6:4]
CLC2 Negative Edge	_CLC2NInterrupt	186	178	0x000178	IFS11[2]	IEC11[2]	IPC44[10:8]
CLC3 Negative Edge	_CLC3NInterrupt	187	179	0x00017A	IFS11[3]	IEC11[3]	IPC44[14:12]
CLC4 Negative Edge	_CLC4NInterrupt	188	180	0x00017C	IFS11[4]	IEC11[4]	IPC45[2:0]
Input Capture/Output Compare 9	_CCP9Interrupt	189	181	0x00017E	IFS11[5]	IEC11[5]	IPC45[6:4]
CCP9 Timer	_CCT9Interrupt	190	182	0x000180	IFS11[6]	IEC11[6]	IPC45[10:8]
Reserved	Reserved	191-196	183-188	0x00182-0x0018C	—	—	—
UART1 Event	_U1EVTInterrupt	197	189	0x00018E	IFS11[13]	IF2C11[13]	IPC47[6:4]
UART2 Event	_U2EVTInterrupt	198	190	0x000190	IFS11[14]	IF2C11[14]	IPC47[12:8]
UART3 Event	_U3EVTInterrupt	199	191	0x000192	IFS11[15]	IF2C11[15]	IPC47[14:12]
AN24 Done	_ADCAN24Interrupt	200	192	0x000194	IFS12[0]	IEC12[0]	IPC48[2:0]
AN25 Done	_ADCAN25Interrupt	201	193	0x000196	IFS12[1]	IEC12[1]	IPC48[6:4]
PMP Event <sup>(3)</sup>	_PMPInterrupt	202	194	0x000198	IFS12[2]	IEC12[2]	IPC48[10:8]
PMP Error Event <sup>(3)</sup>	_PMPEInterrupt	203	195	0x00019A	IFS12[3]	IEC12[3]	IPC48[14:12]

**Note 1:** Availability is dependent on number of supported ADC channels. Refer to [Table 1](#) and [Table 2](#) for ADC channel availability on device variants.

**2:** Availability is dependent on supported I/O ports. Refer to [Table 8-1](#) for availability on device variants.

**3:** Availability is dependent on supported peripherals. Refer to [Table 1](#) and [Table 2](#).

**TABLE 7-3: INTERRUPT FLAG REGISTERS**

Register	Address	Bit 15	Bit14	Bit 13	Bit 12	Bit 11	Bit 10	Bit 9	Bit 8	Bit 7	Bit 6	Bit 5	Bit 4	Bit 3	Bit 2	Bit 1	Bit 0
IFS0	800h	INT1IF	NVMIF	ECCSBEIF	U1TXIF	U1RXIF	SPI1TXIF	SPI1RXIF	DMA1IF	CCT1IF	CCP1IF	—	DMA0IF	CNBIF	CNAIF	T1IF	INT0IF
IFS1	802h	C1RXIF	SPI2TXIF	SPI2RXIF	U2TXIF	U2RXIF	INT3IF	C1IF	CCT2IF	CCP2IF	—	DMA3IF	INT2IF	CNCIF	DMA2IF	MI2C1IF	SI2C1IF
IFS2	804h	CCT6IF	CCP6IF	DMTIF	CCT5IF	CCP5IF	—	CCT4IF	CCP4IF	—	MI2C2IF	SI2C2IF	CCT3IF	CCP3IF	—	—	—
IFS3	806h	PTGSTIEPFI	—	ICDIF	SPI3TXIF	SPI3RXIF	U3TXIF	U3RXIF	U3EIF	—	QE12IF	—	C1TXIF	CRCIF	U2EIF	U1EIF	QE11IF
IFS4	808h	CMP3IF	CMP2IF	CMP1IF	CNEIF	CNDIF	PWM8IF	PWM7IF	PWM6IF	PWM5IF	PWM4IF	PWM3IF	PWM2IF	PWM1IF	—	I2C2BCIF	I2C1BCIF
IFS5	80Ah	ADCAN4IF	ADCAN3IF	ADCAN2IF	ADCAN1IF	ADCAN0IF	ADCIF	SENT2EIF	SENT2IF	SENT1EIF	SENT1IF	PTG3IF	PTG2IF	PTG1IF	PTG0IF	PTGWDTIF	—
IFS6	80Ch	ADCAN20IF	ADCAN19IF	ADCAN18IF	ADCAN17IF	ADCAN16IF	ADCAN15IF	ADCAN14IF	ADCAN13IF	ADCAN12IF	ADCAN11IF	ADCAN10IF	ADCAN9IF	ADCAN8IF	ADCAN7IF	ADCAN6IF	ADCAN5IF
IFS7	80Eh	SPI2GIF	SPI1GIF	CLC2PIF	CLC1PIF	ADFLTR3IF	ADFLTR2IF	ADFLTR1IF	ADFLTR0IF	ADCOMP3IF	ADCOMP2IF	ADCOMP1IF	ADCOMP0IF	ADFLTIF	ADCAN23IF	ADCAN22IF	ADCAN21IF
IFS8	810h	MI2C3IF	SI2C3IF	—	—	—	—	—	—	—	—	—	—	—	—	—	SPI3GIF
IFS9	812h	—	—	—	—	—	—	CCT8IF	CCP8IF	—	CCT7IF	CCP7IF	—	—	—	—	I2C3BCIF
IFS10	814h	CLC3PIF	PEVTFIF	PEVTEIF	PEVTDIF	PEVTCIF	PEVTBIF	PEVTAIF	—	—	—	—	—	—	—	—	—
IFS11	816h	U3EVTIF	U2EVTIF	U1EVTIF	—	—	—	—	—	—	CCT9IF	CCP9IF	CLC4NIF	CLC3NIF	CLC2NIF	CLC1NIF	CLC4PIF
IFS12	818h	—	—	—	—	—	—	—	—	—	—	—	—	PMPEIF	PMPIF	ADCAN25IF	ADCAN24IF

Legend: — = Unimplemented.

**TABLE 7-4: INTERRUPT ENABLE REGISTERS**

Register	Address	Bit 15	Bit14	Bit 13	Bit 12	Bit 11	Bit 10	Bit 9	Bit 8	Bit 7	Bit 6	Bit 5	Bit 4	Bit 3	Bit 2	Bit 1	Bit 0
IEC0	820h	INT1IE	NVMIE	ECCSBEIE	U1TXIE	U1RXIE	SPI1TXIE	SPI1RXIE	DMA1IE	CCT1IE	CCP1IE	—	DMA0IE	CNBIE	CNAIE	T1IE	INT0IE
IEC1	822h	C1RXIE	SPI2TXIE	SPI2RXIE	U2TXIE	U2RXIE	INT3IE	C1IE	CCT2IE	CCP2IE	—	DMA3IE	INT2IE	CNCIE	DMA2IE	MI2C1IE	SI2C1IE
IEC2	824h	CCT6IE	CCP6IE	DMTIE	CCT5IE	CCP5IE	—	CCT4IE	CCP4IE	—	MI2C2IE	SI2C2IE	CCT3IE	CCP3IE	—	—	—
IEC3	826h	PTGSTIEPIE	—	ICDIE	SPI3TXIE	SPI3RXIE	U3TXIE	U3RXIE	U3EIE	—	QE12IE	—	C1TXIE	CRCIE	U2EIE	U1EIE	QE11IE
IEC4	828h	CMP3IE	CMP2IE	CMP1IE	CNEIE	CNDIE	PWM8IE	PWM7IE	PWM6IE	PWM5IE	PWM4IE	PWM3IE	PWM2IE	PWM1IE	—	I2C2BCIE	I2C1BCIE
IEC5	82Ah	ADCAN4IE	ADCAN3IE	ADCAN2IE	ADCAN1IE	ADCAN0IE	ADCIE	SENT2EIE	SENT2IE	SENT1EIE	SENT1IE	PTG3IE	PTG2IE	PTG1IE	PTG0IE	PTGWDTIE	—
IEC6	82Ch	ADCAN20IE	ADCAN19IE	ADCAN18IE	ADCAN17IE	ADCAN16IE	ADCAN15IE	ADCAN14IE	ADCAN13IE	ADCAN12IE	ADCAN11IE	ADCAN10IE	ADCAN9IE	ADCAN8IE	ADCAN7IE	ADCAN6IE	ADCAN5IE
IEC7	82Eh	SPI2GIE	SPI1GIE	CLC2PIE	CLC1PIE	ADFLTR3IE	ADFLTR2IE	ADFLTR1IE	ADFLTR0IE	ADCOMP3IE	ADCOMP2IE	ADCOMP1IE	ADCOMP0IE	ADFLTIE	ADCAN23IE	ADCAN22IE	ADCAN21IE
IEC8	830h	MI2C3IE	SI2C3IE	—	—	—	—	—	—	—	—	—	—	—	—	—	SPI3GIE
IEC9	832h	—	—	—	—	—	—	CCT8IE	CCP8IE	—	CCT7IE	CCP7IE	—	—	—	—	I2C3BCIE
IEC10	834h	CLC3PIE	PEVTFIE	PEVTEIE	PEVTDIE	PEVTCIE	PEVTBIE	PEVTAIE	—	—	—	—	—	—	—	—	—
IEC11	836h	U3EVTIE	U2EVTIE	U1EVTIE	—	—	—	—	—	—	CCT9IE	CCP9IE	CLC4NIE	CLC3NIE	CLC2NIE	CLC1NIE	CLC4PIE
IEC12	838h	—	—	—	—	—	—	—	—	—	—	—	—	PMPEIE	PMPIE	ADCAN25IE	ADCAN24IE

Legend: — = Unimplemented.

**TABLE 7-5: INTERRUPT PRIORITY REGISTERS**

Register	Address	Bit 15	Bit14	Bit 13	Bit 12	Bit 11	Bit 10	Bit 9	Bit 8	Bit 7	Bit 6	Bit 5	Bit 4	Bit 3	Bit 2	Bit 1	Bit 0
IPC0	840h	—	CNBIP2	CNBIP1	CNBIP0	—	CNAIP2	CNAIP1	CNAIP0	—	T1IP2	T1IP1	T1IP0	—	INT0IP2	INT0IP1	INT0IP0
IPC1	842h	—	CCT1IP2	CCT1IP1	CCT1IP0	—	CCP1IP2	CCP1IP1	CCP1IP0	—	—	—	—	—	DMA0IP2	DMA0IP1	DMA0IP0
IPC2	844h	—	U1RXIP2	U1RXIP1	U1RXIP0	—	SPI1TXIP2	SPI1TXIP1	SPI1TXIP0	—	SPI1RXIP2	SPI1RXIP1	SPI1RXIP0	—	DMA1IP2	DMA1IP1	DMA1IP0
IPC3	846h	—	INT1IP2	INT1IP1	INT1IP0	—	NVMIP2	NVMIP1	NVMIP0	—	ECCSBEIP2	ECCSBEIP1	ECCSBEIP0	—	U1TXIP2	U1TXIP1	U1TXIP0
IPC4	848h	—	CNCIP2	CNCIP1	CNCIP0	—	DMA2IP2	DMA2IP1	DMA2IP0	—	M2C1IP2	M2C1IP1	M2C1IP0	—	SI2C1IP2	SI2C1IP1	SI2C1IP0
IPC5	84Ah	—	CCP2IP2	CCP2IP1	CCP2IP0	—	—	—	—	—	DMA3IP2	DMA3IP1	DMA3IP20	—	INT2IP2	INT2IP1	INT2IP0
IPC6	84Ch	—	U2RXIP2	U2RXIP1	U2RXIP0	—	INT3IP2	INT3IP1	INT3IP0	—	C1IP2	C1IP1	C1IP0	—	CCT2IP2	CCT2IP1	CCT2IP0
IPC7	84Eh	—	C1RXIP2	C1RXIP1	C1RXIP0	—	SPI2TXIP2	SPI2TXIP1	SPI2TXIP0	—	SPI2RXIP2	SPI2RXIP1	SPI2RXIP0	—	U2TXIP2	U2TXIP1	U2TXIP0
IPC8	850h	—	CCP3IP2	CCP3IP1	CCP3IP0	—	—	—	—	—	—	—	—	—	—	—	—
IPC9	852h	—	—	—	—	—	M2C2IP2	M2C2IP1	M2C2IP0	—	SI2C2IP2	SI2C2IP1	SI2C2IP0	—	CCT3IP2	CCT3IP1	CCT3IP0
IPC10	854h	—	CCP5IP2	CCP5IP1	CCP5IP0	—	—	—	—	—	CCT4IP2	CCT4IP1	CCT4IP0	—	CCP4IP2	CCP4IP1	CCP4IP0
IPC11	856h	—	CCT6IP2	CCT6IP1	CCT6IP0	—	CCP6IP2	CCP6IP1	CCP6IP0	—	DMTIP2	DMTIP1	DMTIP0	—	CCT5IP2	CCT5IP1	CCT5IP0
IPC12	858h	—	CRCIP2	CRCIP1	CRCIP0	—	U2EIP2	U2EIP1	U2EIP0	—	U1EIP2	U1EIP1	U1EIP0	—	QE1IP2	QE1IP1	QE1IP0
IPC13	85Ah	—	—	—	—	—	QE2IP2	QE2IP1	QE2IP0	—	—	—	—	—	C1TXIP2	C1TXIP1	C1TXIP0
IPC14	85Ch	—	SPI3RXIP2	SPI3RXIP1	SPI3RXIP0	—	U3TXIP2	U3TXIP1	U3TXIP0	—	U3RXIP2	U3RXIP1	U3RXIP0	—	U3EIP2	U3EIP1	U3EIP0
IPC15	85Eh	—	PTGSTEIP2	PTGSTEIP1	PTGSTEIP0	—	—	—	—	—	ICDIP2	ICDIP1	ICDIP0	—	SPI3TXIP2	SPI3TXIP1	SPI3TXIP0
IPC16	860h	—	PWM1IP2	PWM1IP1	PWM1IP0	—	—	—	—	—	I2C2BCIP2	I2C2BCIP1	I2C2BCIP0	—	I2C1BCIP2	I2C1BCIP1	I2C1BCIP0
IPC17	862h	—	PWM5IP2	PWM5IP1	PWM5IP0	—	PWM4IP2	PWM4IP1	PWM4IP0	—	PWM3IP2	PWM3IP1	PWM3IP0	—	PWM2IP2	PWM2IP1	PWM2IP0
IPC18	864h	—	CNDIP2	CNDIP1	CNDIP0	—	PWM8IP2	PWM8IP1	PWM8IP0	—	PWM7IP2	PWM7IP1	PWM7IP0	—	PWM6IP2	PWM6IP1	PWM6IP0
IPC19	866h	—	CMP3IP2	CMP3IP1	CMP3IP0	—	CMP2IP2	CMP2IP1	CMP2IP0	—	CMP1IP2	CMP1IP1	CMP1IP0	—	CNEIP2	CNEIP1	CNEIP0
IPC20	868h	—	PTG1IP2	PTG1IP1	PTG1IP0	—	PTG0IP2	PTG0IP1	PTG0IP0	—	PTGWDTIP2	PTGWDTIP1	PTGWDTIP0	—	—	—	—
IPC21	86Ah	—	SENT1EIP2	SENT1EIP1	SENT1EIP0	—	SENT1IP2	SENT1IP1	SENT1IP0	—	PTG3IP2	PTG3IP1	PTG3IP0	—	PTG2IP2	PTG2IP1	PTG2IP0
IPC22	86Ch	—	ADCAN0IP2	ADCAN0IP1	ADCAN0IP0	—	ADCIP2	ADCIP1	ADCIP0	—	SENT2EIP2	SENT2EIP1	SENT2EIP0	—	SENT2IP2	SENT2IP1	SENT2IP0
IPC23	86Eh	—	ADCAN4IP2	ADCAN4IP1	ADCAN4IP0	—	ADCAN3IP2	ADCAN3IP1	ADCAN3IP0	—	ADCAN2IP2	ADCAN2IP1	ADCAN2IP0	—	ADCAN1IP2	ADCAN1IP1	ADCAN1IP0
IPC24	870h	—	ADCAN8IP2	ADCAN8IP1	ADCAN8IP0	—	ADCAN7IP2	ADCAN7IP1	ADCAN7IP0	—	ADCAN6IP2	ADCAN6IP1	ADCAN6IP0	—	ADCAN5IP2	ADCAN5IP1	ADCAN5IP0
IPC25	872h	—	ADCAN12IP2	ADCAN12IP1	ADCAN12IP0	—	ADCAN11IP2	ADCAN11IP1	ADCAN11IP0	—	ADCAN10IP2	ADCAN10IP1	ADCAN10IP0	—	ADCAN9IP2	ADCAN9IP1	ADCAN9IP0
IPC26	874h	—	ADCAN16IP2	ADCAN16IP1	ADCAN16IP0	—	ADCAN15IP2	ADCAN15IP1	ADCAN15IP0	—	ADCAN14IP2	ADCAN14IP1	ADCAN14IP0	—	ADCAN13IP2	ADCAN13IP1	ADCAN13IP0
IPC27	876h	—	ADCAN20IP2	ADCAN20IP1	ADCAN20IP0	—	ADCAN19IP2	ADCAN19IP1	ADCAN19IP0	—	ADCAN18IP2	ADCAN18IP1	ADCAN18IP0	—	ADCAN17IP2	ADCAN17IP1	ADCAN17IP0
IPC28	878h	—	ADFLTIP2	ADFLTIP1	ADFLTIP0	—	ADCAN23IP2	ADCAN23IP1	ADCAN22IP0	—	ADCAN22IP2	ADCAN22IP1	ADCAN22IP0	—	ADCAN21IP2	ADCAN21IP1	ADCAN21IP0
IPC29	87Ah	—	ADCMP3IP2	ADCMP3IP1	ADCMP3IP0	—	ADCMP2IP2	ADCMP2IP1	ADCMP2IP0	—	ADCMP1IP2	ADCMP1IP1	ADCMP1IP0	—	ADCMP0IP2	ADCMP0IP1	ADCMP0IP0
IPC30	87Ch	—	ADFLTR3IP2	ADFLTR3IP1	ADFLTR3IP0	—	ADFLTR2IP2	ADFLTR2IP1	ADFLTR2IP0	—	ADFLTR1IP2	ADFLTR1IP1	ADFLTR1IP0	—	ADFLTR0IP2	ADFLTR0IP1	ADFLTR0IP0
IPC31	87Eh	—	SPI2GIP0	SPI2GIP1	SPI2GIP0	—	SPI1GIP2	SPI1GIP1	SPI1GIP0	—	CLC2PIP2	CLC2PIP1	CLC2PIP0	—	CLC1PIP2	CLC1PIP1	CLC1PIP0
IPC32	880h	—	—	—	—	—	—	—	—	—	—	—	—	—	SPI3GIP2	SPI3GIP1	SPI3GIP0
IPC33	882h	—	—	—	—	—	—	—	—	—	—	—	—	—	—	—	—
IPC34	884h	—	—	—	—	—	—	—	—	—	—	—	—	—	—	—	—

Legend: — = Unimplemented.

**TABLE 7-5: INTERRUPT PRIORITY REGISTERS (CONTINUED)**

Register	Address	Bit 15	Bit 14	Bit 13	Bit 12	Bit 11	Bit 10	Bit 9	Bit 8	Bit 7	Bit 6	Bit 5	Bit 4	Bit 3	Bit 2	Bit 1	Bit 0
IPC35	886h	—	MI2C3IP2	MI2C3IP1	MI2C3IP1	—	SI2C3IP2	SI2C3IP1	SI2C3IP0	—	—	—	—	—	—	—	—
IPC36	888h	—	—	—	—	—	—	—	—	—	—	—	—	—	I2C3BCIP2	I2C3BCIP1	I2C3BCIP0
IPC37	88Ah	—	—	—	—	—	CCT7IP2	CCT7IP1	CCT7IP0	—	CCP7IP2	CCP7IP1	CCP7IP0	—	—	—	—
IPC38	88Ch	—	—	—	—	—	—	—	—	—	CCT8IP2	CCT8IP1	CCT8IP0	—	CCP8IP2	CCP8IP1	CCP8IP0
IPC39	88Eh	—	—	—	—	—	—	—	—	—	—	—	—	—	—	—	—
IPC40	890h	—	—	—	—	—	—	—	—	—	—	—	—	—	—	—	—
IPC41	892h	—	—	—	—	—	—	—	—	—	—	—	—	—	—	—	—
IPC42	894h	—	PEVTCIP2	PEVTCIP1	PEVTCIP0	—	PEVTBIP2	PEVTBIP1	PEVTBIP0	—	PEVTAIP2	PEVTAIP1	PEVTAIP0	—	—	—	—
IPC43	896h	—	CLC3PIP2	CLC3PIP1	CLC3PIP0	—	PEVTFIP2	PEVTFIP1	PEVTFIP0	—	PEVTEIP2	PEVTEIP1	PEVTEIP0	—	PEVTDIP2	PEVTDIP1	PEVTDIP0
IPC44	898h	—	CLC3NIP2	CLC3NIP1	CLC3NIP0	—	CLC2NIP2	CLC2NIP1	CLC2NIP0	—	CLC1NIP2	CLC1NIP1	CLC1NIP0	—	CLC4PIP2	CLC4PIP1	CLC4PIP0
IPC45	89Ah	—	—	—	—	—	CCT9IP2	CCT9IP1	CCT9IP0	—	CCP9IP2	CCP9IP1	CCP9IP0	—	CLC4NIP2	CLC4NIP1	CLC4NIP0
IPC46	89Ch	—	—	—	—	—	—	—	—	—	—	—	—	—	—	—	—
IPC47	89Eh	—	U3EVTIP2	U3EVTIP1	U3EVTIP0	—	U2EVTIP2	U2EVTIP1	U2EVTIP0	—	U1EVTIP2	U1EVTIP1	U1EVTIP0	—	—	—	—
IPC48	900h	—	PMPEIP2	PMPEIP1	PMPEIP0	—	PMPPIP2	PMPPIP1	PMPPIP0	—	ADCAN25IP2	ADCAN25IP1	ADCAN25IP0	—	ADCAN24IP2	ADCAN24IP1	ADCAN24IP0

**Legend:** — = Unimplemented.

# dsPIC33CK256MP508 FAMILY

---

## 7.3 Interrupt Resources

Many useful resources are provided on the main product page of the Microchip website for the devices listed in this data sheet. This product page contains the latest updates and additional information.

### 7.3.1 KEY RESOURCES

- “**Interrupts**” (DS70000600) in the “*dsPIC33/PIC24 Family Reference Manual*”
- Code Samples
- Application Notes
- Software Libraries
- Webinars
- All Related “*dsPIC33/PIC24 Family Reference Manual*” Sections
- Development Tools

## 7.4 Interrupt Control and Status Registers

The dsPIC33CK256MP508 family devices implement the following registers for the interrupt controller:

- INTCON1
- INTCON2
- INTCON3
- INTCON4
- INTTREG

### 7.4.1 INTCON1 THROUGH INTCON4

Global interrupt control functions are controlled from INTCON1, INTCON2, INTCON3 and INTCON4.

INTCON1 contains the Interrupt Nesting Disable bit (NSTDIS), as well as the control and status flags for the processor trap sources.

The INTCON2 register controls external interrupt request signal behavior, contains the Global Interrupt Enable bit (GIE) and the Alternate Interrupt Vector Table Enable bit (AIVTEN).

INTCON3 contains the status flags for the Auxiliary PLL and DO stack overflow status trap sources.

The INTCON4 register contains the Software Generated Hard Trap Status bit (SGHT).

### 7.4.2 IFSx

The IFSx registers maintain all of the interrupt request flags. Each source of interrupt has a status bit, which is set by the respective peripherals or external signal and is cleared via software.

### 7.4.3 IECx

The IECx registers maintain all of the interrupt enable bits. These control bits are used to individually enable interrupts from the peripherals or external signals.

### 7.4.4 IPCx

The IPCx registers are used to set the Interrupt Priority Level (IPL) for each source of interrupt. Each user interrupt source can be assigned to one of seven priority levels.

### 7.4.5 INTTREG

The INTTREG register contains the associated interrupt vector number and the new CPU Interrupt Priority Level, which are latched into the Vector Number (VECNUM[7:0]) and Interrupt Level bits (ILR[3:0]) fields in the INTTREG register. The new Interrupt Priority Level is the priority of the pending interrupt.

The interrupt sources are assigned to the IFSx, IECx and IPCx registers in the same sequence as they are listed in [Table 7-2](#). For example, INT0 (External Interrupt 0) is shown as having Vector Number 8 and a natural order priority of 0. Thus, the INT0IF bit is found in IFS0[0], the INT0IE bit in IEC0[0] and the INT0IP[2:0] bits in the first position of IPC0 (IPC0[2:0]).

### 7.4.6 STATUS/CONTROL REGISTERS

Although these registers are not specifically part of the interrupt control hardware, two of the CPU Control registers contain bits that control interrupt functionality. For more information on these registers, refer to “**Enhanced CPU**” (DS70005158) in the “*dsPIC33/PIC24 Family Reference Manual*”.

- The CPU STATUS Register, SR, contains the IPL[2:0] bits (SR[7:5]). These bits indicate the current CPU Interrupt Priority Level. The user software can change the current CPU Interrupt Priority Level by writing to the IPLx bits.
- The CORCON register contains the IPL3 bit, which together with IPL[2:0], also indicates the current CPU priority level. IPL3 is a read-only bit so that trap events cannot be masked by the user software.

All Interrupt registers are described in [Register 7-3](#) through [Register 7-7](#) in the following pages.



# dsPIC33CK256MP508 FAMILY

## REGISTER 7-1: SR: CPU STATUS REGISTER<sup>(1)</sup>

R/W-0	R/W-0	R/W-0	R/W-0	R/C-0	R/C-0	R-0	R/W-0
OA	OB	SA	SB	OAB	SAB	DA	DC
bit 15						bit 8	

R/W-0 <sup>(3)</sup>	R/W-0 <sup>(3)</sup>	R/W-0 <sup>(3)</sup>	R-0	R/W-0	R/W-0	R/W-0	R/W-0
IPL2 <sup>(2)</sup>	IPL1 <sup>(2)</sup>	IPL0 <sup>(2)</sup>	RA	N	OV	Z	C
bit 7						bit 0	

<b>Legend:</b>	C = Clearable bit
R = Readable bit	W = Writable bit
-n = Value at POR	'1' = Bit is set
	U = Unimplemented bit, read as '0'
	'0' = Bit is cleared
	x = Bit is unknown

### bit 7-5 **IPL[2:0]: CPU Interrupt Priority Level Status bits<sup>(2,3)</sup>**

- 111 = CPU Interrupt Priority Level is 7 (15); user interrupts are disabled
- 110 = CPU Interrupt Priority Level is 6 (14)
- 101 = CPU Interrupt Priority Level is 5 (13)
- 100 = CPU Interrupt Priority Level is 4 (12)
- 011 = CPU Interrupt Priority Level is 3 (11)
- 010 = CPU Interrupt Priority Level is 2 (10)
- 001 = CPU Interrupt Priority Level is 1 (9)
- 000 = CPU Interrupt Priority Level is 0 (8)

- Note 1:** For complete register details, see [Register 3-1](#).
- 2:** The IPL[2:0] bits are concatenated with the IPL[3] bit (CORCON[3]) to form the CPU Interrupt Priority Level. The value in parentheses indicates the IPL, if IPL[3] = 1. User interrupts are disabled when IPL[3] = 1.
- 3:** The IPL[2:0] Status bits are read-only when the NSTDIS bit (INTCON1[15]) = 1.

# dsPIC33CK256MP508 FAMILY

## REGISTER 7-2: CORCON: CORE CONTROL REGISTER<sup>(1)</sup>

R/W-0	U-0	R/W-0	R/W-0	R/W-0	R-0	R-0	R-0
VAR	—	US1	US0	EDT	DL2	DL1	DL0
bit 15							bit 8

R/W-0	R/W-0	R/W-1	R/W-0	R/C-0	R-0	R/W-0	R/W-0
SATA	SATB	SATDW	ACCSAT	IPL3 <sup>(2)</sup>	SFA	RND	IF
bit 7							bit 0

<b>Legend:</b>	C = Clearable bit
R = Readable bit	W = Writable bit
-n = Value at POR	'1' = Bit is set
	U = Unimplemented bit, read as '0'
	'0' = Bit is cleared
	x = Bit is unknown

bit 15      **VAR:** Variable Exception Processing Latency Control bit  
                  1 = Variable exception processing latency is enabled  
                  0 = Fixed exception processing latency is enabled

bit 3      **IPL3:** CPU Interrupt Priority Level Status bit 3<sup>(2)</sup>  
                  1 = CPU Interrupt Priority Level is greater than 7  
                  0 = CPU Interrupt Priority Level is 7 or less

- Note 1:** For complete register details, see [Register 3-2](#).  
**Note 2:** The IPL3 bit is concatenated with the IPL[2:0] bits (SR[7:5]) to form the CPU Interrupt Priority Level.

# dsPIC33CK256MP508 FAMILY

## REGISTER 7-3: INTCON1: INTERRUPT CONTROL REGISTER 1

R/W-0	R/W-0	R/W-0	R/W-0	R/W-0	R/W-0	R/W-0	R/W-0
NSTDIS	OVAERR	OVBERR	COVAERR	COVBERR	OVATE	OVBTE	COVTE
bit 15							bit 8

R/W-0	R/W-0	U-0	R/W-0	R/W-0	R/W-0	R/W-0	U-0
SFTACERR	DIV0ERR	—	MATHERR	ADDRERR	STKERR	OSCFAIL	—
bit 7							bit 0

### Legend:

R = Readable bit	W = Writable bit	U = Unimplemented bit, read as '0'
-n = Value at POR	'1' = Bit is set	'0' = Bit is cleared
		x = Bit is unknown

- bit 15      **NSTDIS:** Interrupt Nesting Disable bit  
1 = Interrupt nesting is disabled  
0 = Interrupt nesting is enabled
- bit 14      **OVAERR:** Accumulator A Overflow Trap Flag bit  
1 = Trap was caused by an overflow of Accumulator A  
0 = Trap was not caused by an overflow of Accumulator A
- bit 13      **OVBERR:** Accumulator B Overflow Trap Flag bit  
1 = Trap was caused by an overflow of Accumulator B  
0 = Trap was not caused by an overflow of Accumulator B
- bit 12      **COVAERR:** Accumulator A Catastrophic Overflow Trap Flag bit  
1 = Trap was caused by a catastrophic overflow of Accumulator A  
0 = Trap was not caused by a catastrophic overflow of Accumulator A
- bit 11      **COVBERR:** Accumulator B Catastrophic Overflow Trap Flag bit  
1 = Trap was caused by a catastrophic overflow of Accumulator B  
0 = Trap was not caused by a catastrophic overflow of Accumulator B
- bit 10      **OVATE:** Accumulator A Overflow Trap Enable bit  
1 = Trap overflow of Accumulator A  
0 = Trap is disabled
- bit 9        **OVBTE:** Accumulator B Overflow Trap Enable bit  
1 = Trap overflow of Accumulator B  
0 = Trap is disabled
- bit 8        **COVTE:** Catastrophic Overflow Trap Enable bit  
1 = Trap catastrophic overflow of Accumulator A or B is enabled  
0 = Trap is disabled
- bit 7        **SFTACERR:** Shift Accumulator Error Status bit  
1 = Math error trap was caused by an invalid accumulator shift  
0 = Math error trap was not caused by an invalid accumulator shift
- bit 6        **DIV0ERR:** Divide-by-Zero Error Status bit  
1 = Math error trap was caused by a divide-by-zero  
0 = Math error trap was not caused by a divide-by-zero
- bit 5        **Unimplemented:** Read as '0'
- bit 4        **MATHERR:** Math Error Status bit  
1 = Math error trap has occurred  
0 = Math error trap has not occurred
- bit 3        **ADDRERR:** Address Error Trap Status bit  
1 = Address error trap has occurred  
0 = Address error trap has not occurred

# dsPIC33CK256MP508 FAMILY

---

## REGISTER 7-3: INTCON1: INTERRUPT CONTROL REGISTER 1 (CONTINUED)

- bit 2      **STKERR:** Stack Error Trap Status bit  
            1 = Stack error trap has occurred  
            0 = Stack error trap has not occurred
- bit 1      **OSCFAIL:** Oscillator Failure Trap Status bit  
            1 = Oscillator failure trap has occurred  
            0 = Oscillator failure trap has not occurred
- bit 0      **Unimplemented:** Read as '0'

# dsPIC33CK256MP508 FAMILY

## REGISTER 7-4: INTCON2: INTERRUPT CONTROL REGISTER 2

R/W-1	R/W-0	R/W-0	U-0	U-0	U-0	U-0	R/W-0
GIE	DISI	SWTRAP	—	—	—	—	AIVTEN
bit 15							bit 8

U-0	U-0	U-0	U-0	R/W-0	R/W-0	R/W-0	R/W-0
—	—	—	—	INT3EP	INT2EP	INT1EP	INT0EP
bit 7							bit 0

### Legend:

R = Readable bit                      W = Writable bit                      U = Unimplemented bit, read as '0'  
-n = Value at POR                      '1' = Bit is set                      '0' = Bit is cleared                      x = Bit is unknown

- bit 15            **GIE:** Global Interrupt Enable bit  
1 = Interrupts and associated IE bits are enabled  
0 = Interrupts are disabled, but traps are still enabled
- bit 14            **DISI:** DISI Instruction Status bit  
1 = DISI instruction is active  
0 = DISI instruction is not active
- bit 13            **SWTRAP:** Software Trap Status bit  
1 = Software trap is enabled  
0 = Software trap is disabled
- bit 12-9        **Unimplemented:** Read as '0'
- bit 8            **AIVTEN:** Alternate Interrupt Vector Table Enable bit  
1 = Uses Alternate Interrupt Vector Table  
0 = Uses standard Interrupt Vector Table
- bit 7-4        **Unimplemented:** Read as '0'
- bit 3            **INT3EP:** External Interrupt 3 Edge Detect Polarity Select bit  
1 = Interrupt on negative edge  
0 = Interrupt on positive edge
- bit 2            **INT2EP:** External Interrupt 2 Edge Detect Polarity Select bit  
1 = Interrupt on negative edge  
0 = Interrupt on positive edge
- bit 1            **INT1EP:** External Interrupt 1 Edge Detect Polarity Select bit  
1 = Interrupt on negative edge  
0 = Interrupt on positive edge
- bit 0            **INT0EP:** External Interrupt 0 Edge Detect Polarity Select bit  
1 = Interrupt on negative edge  
0 = Interrupt on positive edge

# dsPIC33CK256MP508 FAMILY

## REGISTER 7-5: INTCON3: INTERRUPT CONTROL REGISTER 3

U-0	U-0	U-0	U-0	U-0	U-0	R/W-0	R/W-0
—	—	—	—	—	—	CAN <sup>(1)</sup>	NAE
bit 15						bit 8	

U-0	U-0	R/W-0	R/W-0	U-0	U-0	U-0	R/W-0
—	—	DAE	DOOVR	—	—	—	APLL
bit 7						bit 0	

### Legend:

R = Readable bit

W = Writable bit

U = Unimplemented bit, read as '0'

-n = Value at POR

'1' = Bit is set

'0' = Bit is cleared

x = Bit is unknown

- bit 15-10     **Unimplemented:** Read as '0'
- bit 9         **CAN:** CAN Address Error Soft Trap Status bit<sup>(1)</sup>  
               1 = CAN address error soft trap has occurred  
               0 = CAN address error soft trap has not occurred
- bit 8         **NAE:** NVM Address Error Soft Trap Status bit  
               1 = NVM address error soft trap has occurred  
               0 = NVM address error soft trap has not occurred
- bit 7-6       **Unimplemented:** Read as '0'
- bit 5         **DAE:** DMA Address Error (Soft) Trap Status bit  
               1 = DMA address error trap has occurred  
               0 = Trap has not occurred
- bit 4         **DOOVR:** DO Stack Overflow Soft Trap Status bit  
               1 = DO stack overflow soft trap has occurred  
               0 = DO stack overflow soft trap has not occurred
- bit 3-1       **Unimplemented:** Read as '0'
- bit 0         **APLL:** Auxiliary PLL Loss of Lock Soft Trap Status bit  
               1 = APLL lock soft trap has occurred  
               0 = APLL lock soft trap has not occurred

**Note 1:** The CAN peripheral is not available on all devices. Refer to [Table 1](#) and [Table 2](#) for availability.

# dsPIC33CK256MP508 FAMILY

## REGISTER 7-6: INTCON4: INTERRUPT CONTROL REGISTER 4

U-0	U-0	U-0	U-0	U-0	U-0	U-0	U-0
—	—	—	—	—	—	—	—
bit 15							bit 8

U-0	U-0	U-0	U-0	U-0	U-0	R/W-0	R/W-0
—	—	—	—	—	—	ECCDBE	SGHT
bit 7						bit 0	

### Legend:

R = Readable bit                      W = Writable bit                      U = Unimplemented bit, read as '0'  
 -n = Value at POR                      '1' = Bit is set                      '0' = Bit is cleared                      x = Bit is unknown

- bit 15-2        **Unimplemented:** Read as '0'
- bit 1         **ECCDBE:** ECC Double-Bit Error Trap bit
  - 1 = ECC double-bit error trap has occurred
  - 0 = ECC double-bit error trap has not occurred
- bit 0         **SGHT:** Software Generated Hard Trap Status bit
  - 1 = Software generated hard trap has occurred
  - 0 = Software generated hard trap has not occurred

# dsPIC33CK256MP508 FAMILY

## REGISTER 7-7: INTTREG: INTERRUPT CONTROL AND STATUS REGISTER

U-0	U-0	R/W-0	U-0	R-0	R-0	R-0	R-0
—	—	VHOLD	—	ILR3	ILR2	ILR1	ILR0
bit 15						bit 8	

R-0	R-0	R-0	R-0	R-0	R-0	R-0	R-0
VECNUM[7:0]							
bit 7						bit 0	

### Legend:

R = Readable bit	W = Writable bit	U = Unimplemented bit, read as '0'
-n = Value at POR	'1' = Bit is set	'0' = Bit is cleared      x = Bit is unknown

- bit 15-14      **Unimplemented:** Read as '0'
- bit 13        **VHOLD:** Vector Number Capture Enable bit
  - 1 = VECNUM[7:0] bits read current value of vector number encoding tree (i.e., highest priority pending interrupt)
  - 0 = Vector number latched into VECNUM[7:0] at Interrupt Acknowledge and retained until next IACK
- bit 12        **Unimplemented:** Read as '0'
- bit 11-8      **ILR[3:0]:** New CPU Interrupt Priority Level bits
  - 1111 = CPU Interrupt Priority Level is 15
  - ...
  - 0001 = CPU Interrupt Priority Level is 1
  - 0000 = CPU Interrupt Priority Level is 0
- bit 7-0       **VECNUM[7:0]:** Vector Number of Pending Interrupt bits
  - 11111111 = 255, Reserved; do not use
  - ...
  - 00001001 = 9, IC1 – Input Capture 1
  - 00001000 = 8, INT0 – External Interrupt 0
  - 00000111 = 7, Reserved; do not use
  - 00000110 = 6, Generic soft trap
  - 00000101 = 5, Reserved; do not use
  - 00000100 = 4, Math error trap
  - 00000011 = 3, Stack error trap
  - 00000010 = 2, Generic hard trap
  - 00000001 = 1, Address error trap
  - 00000000 = 0, Oscillator fail trap



## 8.0 I/O PORTS

**Note 1:** This data sheet summarizes the features of the dsPIC33CK256MP508 family of devices. It is not intended to be a comprehensive reference source. To complement the information in this data sheet, refer to “I/O Ports with Edge Detect” ([www.microchip.com/DS70005322](http://www.microchip.com/DS70005322)) in the “dsPIC33/PIC24 Family Reference Manual”.

**2:** Some registers and associated bits described in this section may not be available on all devices.

Many of the device pins are shared among the peripherals and the Parallel I/O ports. All I/O input ports feature Schmitt Trigger inputs for improved noise immunity. The PORT registers are located in the SFR.

Some of the key features of the I/O ports are:

- Individual Output Pin Open-Drain Enable/Disable
- Individual Input Pin Weak Pull-up and Pull-Down
- Monitor Selective Inputs and Generate Interrupt when Change in Pin State is Detected
- Operation during Sleep and Idle modes

## 8.1 Parallel I/O (PIO) Ports

All port pins have 12 registers directly associated with their operation as digital I/Os. The Data Direction register (TRISx) determines whether the pin is an input or an output. If the data direction bit is a ‘1’, then the pin is an input.

All port pins are defined as inputs after a Reset. Reads from the latch (LATx), read the latch. Writes to the latch, write the latch. Reads from the port (PORTx), read the port pins, while writes to the port pins, write the latch. Any bit and its associated data and control registers that are not valid for a particular device are disabled. This means the corresponding LATx and TRISx registers, and the port pin are read as zeros.

When a pin is shared with another peripheral or function that is defined as an input only, it is nevertheless regarded as a dedicated port because there is no other competing source of outputs. [Table 8-1](#) shows the pin availability. [Table 8-2](#) shows the 5V input tolerant pins across this device.

# dsPIC33CK256MP508 FAMILY

**TABLE 8-1: PIN AND ANSELx AVAILABILITY**

Device	Rx15	Rx14	Rx13	Rx12	Rx11	Rx10	Rx9	Rx8	Rx7	Rx6	Rx5	Rx4	Rx3	Rx2	Rx1	Rx0
<b>PORTA</b>																
dsPIC33XXXMP508/208	—	—	—	—	—	—	—	—	—	—	—	X	X	X	X	X
dsPIC33XXXMP506/206	—	—	—	—	—	—	—	—	—	—	—	X	X	X	X	X
dsPIC33XXXMP505/205	—	—	—	—	—	—	—	—	—	—	—	X	X	X	X	X
dsPIC33XXXMP503/203	—	—	—	—	—	—	—	—	—	—	—	X	X	X	X	X
dsPIC33XXXMP502/202	—	—	—	—	—	—	—	—	—	—	—	X	X	X	X	X
ANSELA	—	—	—	—	—	—	—	—	—	—	—	X	X	X	X	X
<b>PORTB</b>																
dsPIC33XXXMP508/208	X	X	X	X	X	X	X	X	X	X	X	X	X	X	X	X
dsPIC33XXXMP506/206	X	X	X	X	X	X	X	X	X	X	X	X	X	X	X	X
dsPIC33XXXMP505/205	X	X	X	X	X	X	X	X	X	X	X	X	X	X	X	X
dsPIC33XXXMP503/203	X	X	X	X	X	X	X	X	X	X	X	X	X	X	X	X
dsPIC33XXXMP502/202	X	X	X	X	X	X	X	X	X	X	X	X	X	X	X	X
ANSELB	—	—	—	—	—	—	X	X	X	—	—	X	X	X	X	X
<b>PORTC</b>																
dsPIC33XXXMP508/208	X	X	X	X	X	X	X	X	X	X	X	X	X	X	X	X
dsPIC33XXXMP506/206	X	X	X	X	X	X	X	X	X	X	X	X	X	X	X	X
dsPIC33XXXMP505/205	—	—	X	X	X	X	X	X	X	X	X	X	X	X	X	X
dsPIC33XXXMP503/203	—	—	—	—	—	—	—	—	—	—	X	X	X	X	X	X
dsPIC33XXXMP502/202	—	—	—	—	—	—	—	—	—	—	—	—	—	—	—	—
ANSELC	—	—	—	—	—	—	—	—	X	X	—	—	X	X	X	X
<b>PORTD</b>																
dsPIC33XXXMP508/208	X	X	X	X	X	X	X	X	X	X	X	X	X	X	X	X
dsPIC33XXXMP506/206	X	X	X	X	X	X	X	X	X	X	X	X	X	X	X	X
dsPIC33XXXMP505/205	—	—	X	—	—	X	—	X	—	—	—	—	—	—	X	—
dsPIC33XXXMP503/203	—	—	—	—	—	—	—	—	—	—	—	—	—	—	—	—
dsPIC33XXXMP502/202	—	—	—	—	—	—	—	—	—	—	—	—	—	—	—	—
ANSELD	—	—	X	—	X	X	—	—	—	—	—	—	—	—	—	—
<b>PORTE</b>																
dsPIC33XXXMP508/208	X	X	X	X	X	X	X	X	X	X	X	X	X	X	X	X
dsPIC33XXXMP506/206	—	—	—	—	—	—	—	—	—	—	—	—	—	—	—	—
dsPIC33XXXMP505/205	—	—	—	—	—	—	—	—	—	—	—	—	—	—	—	—
dsPIC33XXXMP503/203	—	—	—	—	—	—	—	—	—	—	—	—	—	—	—	—
dsPIC33XXXMP502/202	—	—	—	—	—	—	—	—	—	—	—	—	—	—	—	—
ANSELE	—	—	—	—	—	—	—	—	—	—	—	X	X	X	X	X

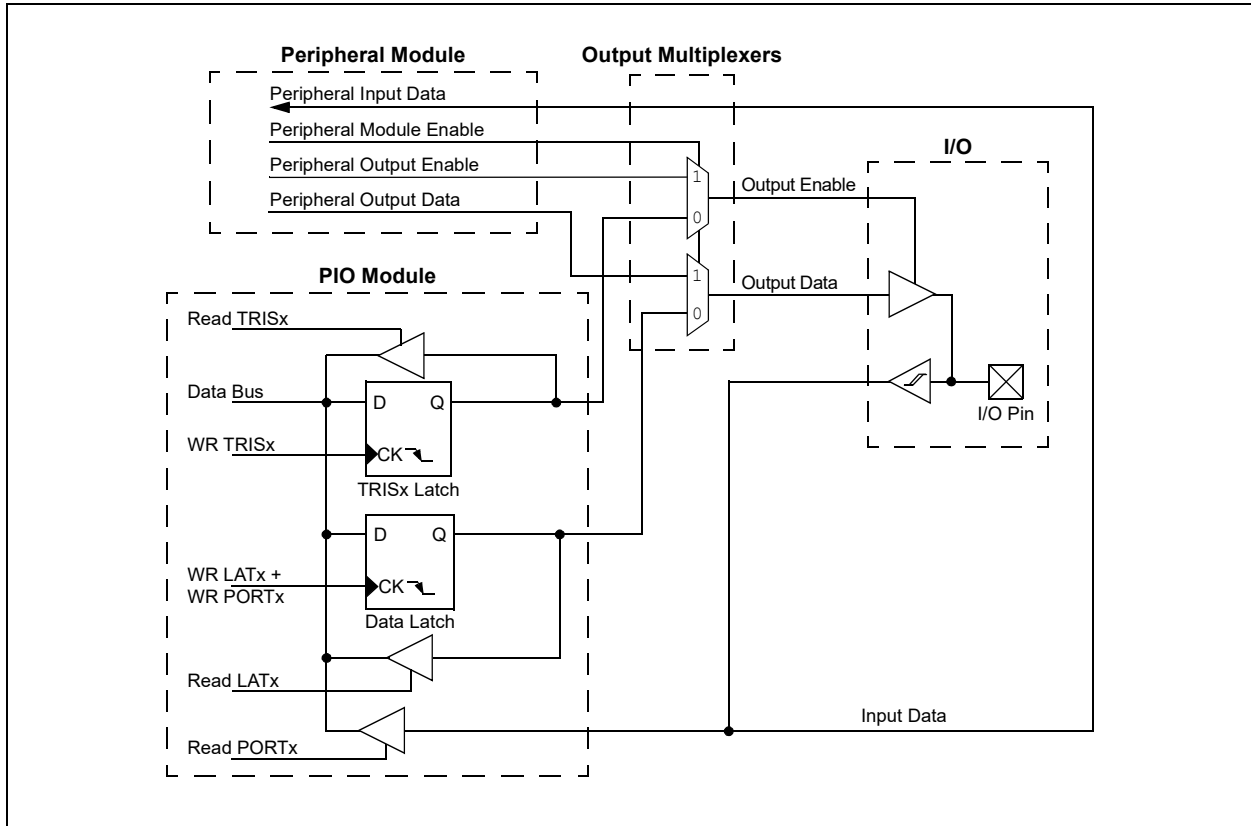
**TABLE 8-2: 5V INPUT TOLERANT PORTS**

PORTA	—	—	—	—	—	—	—	—	—	—	—	RA4	RA3	RA2	RA1	RA0
PORTB	RB15	RB14	RB13	RB12	RB11	RB10	RB9	RB8	RB7	RB6	RB5	RB4	RB3	RB2	RB1	RB0
PORTC	RC15	RC14	RC13	RC12	RC11	RC10	RC9	RC8	RC7	RC6	RC5	RC4	RC3	RC2	RC1	RC0
PORTD	RD15	RD14	RD13	RD12	RD11	RD10	RD9	RD8	RD7	RD6	RD5	RD4	RD3	RD2	RD1	RD0
PORTE	RE15	RE14	RE13	RE12	RE11	RE10	RE9	RE8	RE7	RE6	RE5	RE4	RE3	RE2	RE1	RE0

**Legend:** Shaded pins are up to 5.5 VDC input tolerant.

# dsPIC33CK256MP508 FAMILY

FIGURE 8-1: BLOCK DIAGRAM OF A TYPICAL SHARED PORT STRUCTURE



# dsPIC33CK256MP508 FAMILY

## 8.1.1 OPEN-DRAIN CONFIGURATION

In addition to the PORTx, LATx and TRISx registers for data control, port pins can also be individually configured for either digital or open-drain output. This is controlled by the Open-Drain Enable for PORTx register, ODCx, associated with each port. Setting any of the bits configures the corresponding pin to act as an open-drain output.

The open-drain feature allows the generation of outputs, other than VDD, by using external pull-up resistors. The maximum open-drain voltage allowed on any pin is the same as the maximum VIH specification for that particular pin.

## 8.2 Configuring Analog and Digital Port Pins

The ANSELx registers control the operation of the analog port pins. The port pins that are to function as analog inputs or outputs must have their corresponding ANSELx and TRISx bits set. In order to use port pins for I/O functionality with digital modules, such as timers, UARTs, etc., the corresponding ANSELx bit must be cleared.

The ANSELx registers have a default value of 0xFFFF; therefore, all pins that share analog functions are analog (not digital) by default.

Pins with analog functions affected by the ANSELx registers are listed with a buffer type of analog in the Pinout I/O Descriptions (see Table 1-1).

If the TRISx bit is cleared (output) while the ANSELx bit is set, the digital output level (VOH or VOL) is converted by an analog peripheral, such as the ADC module or comparator module.

When the PORTx register is read, all pins configured as analog input channels are read as cleared (a low level).

Pins configured as digital inputs do not convert an analog input. Analog levels on any pin, defined as a digital input (including the ANx pins), can cause the input buffer to consume current that exceeds the device specifications.

## 8.2.1 I/O PORT WRITE/READ TIMING

One instruction cycle is required between a port direction change or port write operation and a read operation of the same port. Typically, this instruction would be a NOP.

## 8.3 PORT Control Registers

The following registers are in the PORT module:

- Register 8-1: ANSELx (one per port)
- Register 8-2: TRISx (one per port)
- Register 8-3: PORTx (one per port)
- Register 8-4: LATx (one per port)
- Register 8-5: ODCx (one per port)
- Register 8-6: CNPUx (one per port)
- Register 8-7: CNPDx (one per port)
- Register 8-8: CNCONx (one per port – optional)
- Register 8-9: CNEN0x (one per port)
- Register 8-10: CNSTATx (one per port – optional)
- Register 8-11: CNEN1x (one per port)
- Register 8-12: CNFx (one per port)

### REGISTER 8-1: ANSELx: ANALOG SELECT FOR PORTx REGISTER

R/W-1	R/W-1	R/W-1	R/W-1	R/W-1	R/W-1	R/W-1	R/W-1
ANSELx[15:8]							
bit 15				bit 8			

R/W-1	R/W-1	R/W-1	R/W-1	R/W-1	R/W-1	R/W-1	R/W-1
ANSELx[7:0]							
bit 7				bit 0			

#### Legend:

R = Readable bit  
-n = Value at POR

W = Writable bit  
'1' = Bit is set

U = Unimplemented bit, read as '0'  
'0' = Bit is cleared  
x = Bit is unknown

bit 15-0

**ANSELx[15:0]:** Analog Select for PORTx bits

- 1 = Analog input is enabled and digital input is disabled on the PORTx[n] pin
- 0 = Analog input is disabled and digital input is enabled on the PORTx[n] pin

# dsPIC33CK256MP508 FAMILY

## REGISTER 8-2: TRISx: OUTPUT ENABLE FOR PORTx REGISTER

R/W-1	R/W-1	R/W-1	R/W-1	R/W-1	R/W-1	R/W-1	R/W-1
TRISx[15:8]							
bit 15							
bit 8							

R/W-1	R/W-1	R/W-1	R/W-1	R/W-1	R/W-1	R/W-1	R/W-1
TRISx[7:0]							
bit 7							
bit 0							

### Legend:

R = Readable bit                      W = Writable bit                      U = Unimplemented bit, read as '0'  
 -n = Value at POR                      '1' = Bit is set                      '0' = Bit is cleared                      x = Bit is unknown

bit 15-0                      **TRISx[15:0]:** Output Enable for PORTx bits  
 1 = LATx[n] is not driven on the PORTx[n] pin  
 0 = LATx[n] is driven on the PORTx[n] pin

## REGISTER 8-3: PORTx: INPUT DATA FOR PORTx REGISTER

R/W-1	R/W-1	R/W-1	R/W-1	R/W-1	R/W-1	R/W-1	R/W-1
PORTx[15:8]							
bit 15							
bit 8							

R/W-1	R/W-1	R/W-1	R/W-1	R/W-1	R/W-1	R/W-1	R/W-1
PORTx[7:0]							
bit 7							
bit 0							

### Legend:

R = Readable bit                      W = Writable bit                      U = Unimplemented bit, read as '0'  
 -n = Value at POR                      '1' = Bit is set                      '0' = Bit is cleared                      x = Bit is unknown

bit 15-0                      **PORTx[15:0]:** PORTx Data Input Value bits

# dsPIC33CK256MP508 FAMILY

## REGISTER 8-4: LATx: OUTPUT DATA FOR PORTx REGISTER

R/W-x	R/W-x	R/W-x	R/W-x	R/W-x	R/W-x	R/W-x	R/W-x
LATx[15:8]							
bit 15				bit 8			

R/W-x	R/W-x	R/W-x	R/W-x	R/W-x	R/W-x	R/W-x	R/W-x
LATx[7:0]							
bit 7				bit 0			

**Legend:**

R = Readable bit                      W = Writable bit                      U = Unimplemented bit, read as '0'  
 -n = Value at POR                      '1' = Bit is set                      '0' = Bit is cleared                      x = Bit is unknown

bit 15-0                      **LATx[15:0]:** PORTx Data Output Value bits

## REGISTER 8-5: ODCx: OPEN-DRAIN ENABLE FOR PORTx REGISTER

R/W-0	R/W-0	R/W-0	R/W-0	R/W-0	R/W-0	R/W-0	R/W-0
ODCx[15:8]							
bit 15				bit 8			

R/W-0	R/W-0	R/W-0	R/W-0	R/W-0	R/W-0	R/W-0	R/W-0
ODCx[7:0]							
bit 7				bit 0			

**Legend:**

R = Readable bit                      W = Writable bit                      U = Unimplemented bit, read as '0'  
 -n = Value at POR                      '1' = Bit is set                      '0' = Bit is cleared                      x = Bit is unknown

bit 15-0                      **ODCx[15:0]:** PORTx Open-Drain Enable bits  
 1 = Open-drain is enabled on the PORTx pin  
 0 = Open-drain is disabled on the PORTx pin

# dsPIC33CK256MP508 FAMILY

## REGISTER 8-6: CNPUx: CHANGE NOTIFICATION PULL-UP ENABLE FOR PORTx REGISTER

R/W-0	R/W-0	R/W-0	R/W-0	R/W-0	R/W-0	R/W-0	R/W-0
CNPUx[15:8]							
bit 15				bit 8			

R/W-0	R/W-0	R/W-0	R/W-0	R/W-0	R/W-0	R/W-0	R/W-0
CNPUx[7:0]							
bit 7				bit 0			

### Legend:

R = Readable bit	W = Writable bit	U = Unimplemented bit, read as '0'
-n = Value at POR	'1' = Bit is set	'0' = Bit is cleared
		x = Bit is unknown

bit 15-0      **CNPUx[15:0]:** Change Notification Pull-up Enable for PORTx bits  
 1 = The pull-up for PORTx[n] is enabled – takes precedence over the pull-down selection  
 0 = The pull-up for PORTx[n] is disabled

## REGISTER 8-7: CNPDx: CHANGE NOTIFICATION PULL-DOWN ENABLE FOR PORTx REGISTER

R/W-0	R/W-0	R/W-0	R/W-0	R/W-0	R/W-0	R/W-0	R/W-0
CNPDx[15:8]							
bit 15				bit 8			

R/W-0	R/W-0	R/W-0	R/W-0	R/W-0	R/W-0	R/W-0	R/W-0
CNPDx[7:0]							
bit 7				bit 0			

### Legend:

R = Readable bit	W = Writable bit	U = Unimplemented bit, read as '0'
-n = Value at POR	'1' = Bit is set	'0' = Bit is cleared
		x = Bit is unknown

bit 15-0      **CNPDx[15:0]:** Change Notification Pull-down Enable for PORTx bits  
 1 = The pull-down for PORTx[n] is enabled (if the pull-up for PORTx[n] is not enabled)  
 0 = The pull-down for PORTx[n] is disabled

# dsPIC33CK256MP508 FAMILY

## REGISTER 8-8: CNCONx: CHANGE NOTIFICATION CONTROL FOR PORTx REGISTER

R/W-0	U-0	U-0	U-0	R/W-0	U-0	U-0	U-0
ON	—	—	—	CNSTYLE	—	—	—
bit 15				bit 8			
U-0	U-0	U-0	U-0	U-0	U-0	U-0	U-0
—	—	—	—	—	—	—	—
bit 7				bit 0			

### Legend:

R = Readable bit                      W = Writable bit                      U = Unimplemented bit, read as '0'  
 -n = Value at POR                      '1' = Bit is set                      '0' = Bit is cleared                      x = Bit is unknown

- bit 15                      **ON:** Change Notification (CN) Control for PORTx On bit  
                                     1 = CN is enabled  
                                     0 = CN is disabled
- bit 14-12                      **Unimplemented:** Read as '0'
- bit 11                      **CNSTYLE:** Change Notification Style Selection bit  
                                     1 = Edge style (detects edge transitions, CNFx[15:0] bits are used for a Change Notification event)  
                                     0 = Mismatch style (detects change from last port read, CNSTATx[15:0] bits are used for a Change Notification event)
- bit 10-0                      **Unimplemented:** Read as '0'

## REGISTER 8-9: CNEN0x: CHANGE NOTIFICATION INTERRUPT ENABLE FOR PORTx REGISTER

R/W-0	R/W-0	R/W-0	R/W-0	R/W-0	R/W-0	R/W-0	R/W-0
CNEN0x[15:8]							
bit 15				bit 8			
R/W-0	R/W-0	R/W-0	R/W-0	R/W-0	R/W-0	R/W-0	R/W-0
CNEN0x[7:0]							
bit 7				bit 0			

### Legend:

R = Readable bit                      W = Writable bit                      U = Unimplemented bit, read as '0'  
 -n = Value at POR                      '1' = Bit is set                      '0' = Bit is cleared                      x = Bit is unknown

- bit 15-0                      **CNEN0x[15:0]:** Change Notification Interrupt Enable for PORTx bits  
                                     1 = Interrupt-on-change (from the last read value) is enabled for PORTx[n]  
                                     0 = Interrupt-on-change is disabled for PORTx[n]



# dsPIC33CK256MP508 FAMILY

## REGISTER 8-10: CNSTATx: CHANGE NOTIFICATION STATUS FOR PORTx REGISTER

R-0	R-0	R-0	R-0	R-0	R-0	R-0	R-0
CNSTATx[15:8]							
bit 15				bit 8			

R-0	R-0	R-0	R-0	R-0	R-0	R-0	R-0
CNSTATx[7:0]							
bit 7				bit 0			

### Legend:

R = Readable bit                      W = Writable bit                      U = Unimplemented bit, read as '0'  
 -n = Value at POR                      '1' = Bit is set                      '0' = Bit is cleared                      x = Bit is unknown

bit 15-0                      **CNSTATx[15:0]:** Change Notification Status for PORTx bits  
 When CNSTYLE (CNCONx[11]) = 0:  
 1 = Change occurred on PORTx[n] since last read of PORTx[n]  
 0 = Change did not occur on PORTx[n] since last read of PORTx[n]

## REGISTER 8-11: CNEN1x: CHANGE NOTIFICATION EDGE SELECT FOR PORTx REGISTER

R/W-0	R/W-0	R/W-0	R/W-0	R/W-0	R/W-0	R/W-0	R/W-0
CNEN1x[15:8]							
bit 15				bit 8			

R/W-0	R/W-0	R/W-0	R/W-0	R/W-0	R/W-0	R/W-0	R/W-0
CNEN1x[7:0]							
bit 7				bit 0			

### Legend:

R = Readable bit                      W = Writable bit                      U = Unimplemented bit, read as '0'  
 -n = Value at POR                      '1' = Bit is set                      '0' = Bit is cleared                      x = Bit is unknown

bit 15-0                      **CNEN1x[15:0]:** Change Notification Edge Select for PORTx bits

# dsPIC33CK256MP508 FAMILY

## REGISTER 8-12: CNF<sub>x</sub>: CHANGE NOTIFICATION INTERRUPT FLAG FOR PORT<sub>x</sub> REGISTER

R/W-0	R/W-0	R/W-0	R/W-0	R/W-0	R/W-0	R/W-0	R/W-0
CNF <sub>x</sub> [15:8]							
bit 15				bit 8			

R/W-0	R/W-0	R/W-0	R/W-0	R/W-0	R/W-0	R/W-0	R/W-0
CNF <sub>x</sub> [7:0]							
bit 7				bit 0			

### Legend:

R = Readable bit	W = Writable bit	U = Unimplemented bit, read as '0'
-n = Value at POR	'1' = Bit is set	'0' = Bit is cleared
		x = Bit is unknown

bit 15-0 **CNF<sub>x</sub>[15:0]**: Change Notification Interrupt Flag for PORT<sub>x</sub> bits

When CNSTYLE (CNCON<sub>x</sub>[11]) = 1:

1 = An enabled edge event occurred on the PORT<sub>x</sub>[n] pin

0 = An enabled edge event did not occur on the PORT<sub>x</sub>[n] pin

## 8.4 Input Change Notification (ICN)

The Input Change Notification function of the I/O ports allows the dsPIC33CK256MP508 family devices to generate interrupt requests to the processor in response to a Change-of-State (COS) on selected input pins. This feature can detect input Change-of-States, even in Sleep mode, when the clocks are disabled. Every I/O port pin can be selected (enabled) for generating an interrupt request on a Change-of-State. Five control registers are associated with the Change Notification (CN) functionality of each I/O port. To enable the Change Notification feature for the port, the ON bit (CNCONx[15]) must be set.

The CNEN0x and CNEN1x registers contain the CN interrupt enable control bits for each of the input pins. The setting of these bits enables a CN interrupt for the corresponding pins. Also, these bits, in combination with the CNSTYLE bit (CNCONx[11]), define a type of transition when the interrupt is generated. Possible CN event options are listed in [Table 8-3](#).

**TABLE 8-3: CHANGE NOTIFICATION EVENT OPTIONS**

CNSTYLE Bit (CNCONx[11])	CNEN1x Bit	CNEN0x Bit	Change Notification Event Description
0	Does not matter	0	Disabled
0	Does not matter	1	Detects a mismatch between the last read state and the current state of the pin
1	0	0	Disabled
1	0	1	Detects a positive transition only (from '0' to '1')
1	1	0	Detects a negative transition only (from '1' to '0')
1	1	1	Detects both positive and negative transitions

The CNSTATx register indicates whether a change occurred on the corresponding pin since the last read of the PORTx bit. In addition to the CNSTATx register, the CNFx register is implemented for each port. This register contains flags for Change Notification events. These flags are set if the valid transition edge, selected in the CNEN0x and CNEN1x registers, is detected. CNFx stores the occurrence of the event. CNFx bits must be cleared in software to get the next Change Notification interrupt. The CN interrupt is generated only for the I/Os configured as inputs (corresponding TRISx bits must be set).

**Note:** Pull-ups and pull-downs on Input Change Notification pins should always be disabled when the port pin is configured as a digital output.

## 8.5 Peripheral Pin Select (PPS)

A major challenge in general purpose devices is providing the largest possible set of peripheral features, while minimizing the conflict of features on I/O pins. The challenge is even greater on low pin count devices. In an application where more than one peripheral needs to be assigned to a single pin, inconvenient work arounds in application code, or a complete redesign, may be the only option.

Peripheral Pin Select configuration provides an alternative to these choices by enabling peripheral set selection and placement on a wide range of I/O pins. By increasing the pinout options available on a particular device, users can better tailor the device to their entire application, rather than trimming the application to fit the device.

The Peripheral Pin Select configuration feature operates over a fixed subset of digital I/O pins. Users may independently map the input and/or output of most digital peripherals to any one of these I/O pins. Hardware safeguards are included that prevent accidental or spurious changes to the peripheral mapping once it has been established.

### 8.5.1 AVAILABLE PINS

The number of available pins is dependent on the particular device and its pin count. Pins that support the Peripheral Pin Select feature include the label, "RPn", in their full pin designation, where "n" is the remappable pin number. "RP" is used to designate pins that support both remappable input and output functions.

### 8.5.2 AVAILABLE PERIPHERALS

The peripherals managed by the Peripheral Pin Select are all digital only peripherals. These include general serial communications (UART and SPI), general purpose timer clock inputs, timer-related peripherals (input capture and output compare) and interrupt-on-change inputs.

In comparison, some digital only peripheral modules are never included in the Peripheral Pin Select feature. This is because the peripheral's function requires special I/O circuitry on a specific port and cannot be easily connected to multiple pins. One example includes I<sup>2</sup>C modules. A similar requirement excludes all modules with analog inputs, such as the A/D Converter (ADC)

A key difference between remappable and non-remappable peripherals is that remappable peripherals are not associated with a default I/O pin. The peripheral must always be assigned to a specific I/O pin before it can be used. In contrast, non-remappable peripherals are always available on a default pin, assuming that the peripheral is active and not conflicting with another peripheral.

# dsPIC33CK256MP508 FAMILY

When a remappable peripheral is active on a given I/O pin, it takes priority over all other digital I/Os and digital communication peripherals associated with the pin. Priority is given regardless of the type of peripheral that is mapped. Remappable peripherals never take priority over any analog functions associated with the pin.

## 8.5.3 CONTROLLING CONFIGURATION CHANGES

Because peripheral mapping can be changed during run time, some restrictions on peripheral remapping are needed to prevent accidental configuration changes. The dsPIC33CK256MP508 devices have implemented the control register lock sequence.

### 8.5.3.1 Control Register Lock

Under normal operation, writes to the RPINRx and RPORx registers are not allowed. Attempted writes will appear to execute normally, but the contents of the registers will remain unchanged. To change these registers, they must be unlocked in hardware. The register lock is controlled by the IOLOCK bit (RPCON[11]).

Setting IOLOCK prevents writes to the control registers; clearing IOLOCK allows writes. To set or clear IOLOCK, the NVMKEY unlock sequence must be executed:

1. Write 0x55 to NVMKEY.
2. Write 0xAA to NVMKEY.
3. Clear (or set) IOLOCK as a single operation.

IOLOCK remains in one state until changed. This allows all of the Peripheral Pin Selects to be configured with a single unlock sequence, followed by an update to all of the control registers. Then, IOLOCK can be set with a second lock sequence.

## 8.5.4 CONSIDERATIONS FOR PERIPHERAL PIN SELECTION

The ability to control Peripheral Pin Selection introduces several considerations into application design that most users would never think of otherwise. This is particularly true for several common peripherals, which are only available as remappable peripherals.

The main consideration is that the Peripheral Pin Selects are not available on default pins in the device's default (Reset) state. More specifically, because all RPINRx registers reset to '1's and RPORx registers reset to '0's, this means all PPS inputs are tied to Vss, while all PPS outputs are disconnected. This means that before any other application code is executed, the user must initialize the device with the proper peripheral configuration. Because the IOLOCK bit resets in the unlocked state, it is not necessary to execute the unlock sequence after the device has come out of Reset. For application safety, however, it is always better to set IOLOCK and lock the configuration after writing to the control registers.

The NVMKEY unlock sequence must be executed as an Assembly language routine. If the bulk of the application is written in C, or another high-level language, the unlock sequence should be performed by writing in-line assembly or by using the `__builtin_write_RPCON(value)` function provided by the compiler.

Choosing the configuration requires a review of all Peripheral Pin Selects and their pin assignments, particularly those that will not be used in the application. In all cases, unused pin-selectable peripherals should be disabled completely. Unused peripherals should have their inputs assigned to an unused RPn pin function. I/O pins with unused RPn functions should be configured with the null peripheral output.

**Note:** MPLAB® XC16 provides a built-in C language function for unlocking and modifying the RPCON register:

```
__builtin_write_RPCON(value);
```

For more information, see the "MPLAB® XC16 C Compiler User's Guide" (DS50002071).

## 8.5.5 INPUT MAPPING

The inputs of the Peripheral Pin Select options are mapped on the basis of the peripheral. That is, a control register associated with a peripheral dictates the pin it will be mapped to. The RPINRx registers are used to configure peripheral input mapping. Each register contains sets of 8-bit fields, with each set associated with one of the remappable peripherals. Programming a given peripheral's bit field with an appropriate 8-bit index value maps the RPn pin with the corresponding value, or internal signal, to that peripheral. See [Table 8-4](#) for a list of available inputs.

For example, [Figure 8-2](#) illustrates remappable pin selection for the U1RX input. [Example 8-1](#) provides a configuration for bidirectional communication with flow control using UART1. The following input and output functions are used:

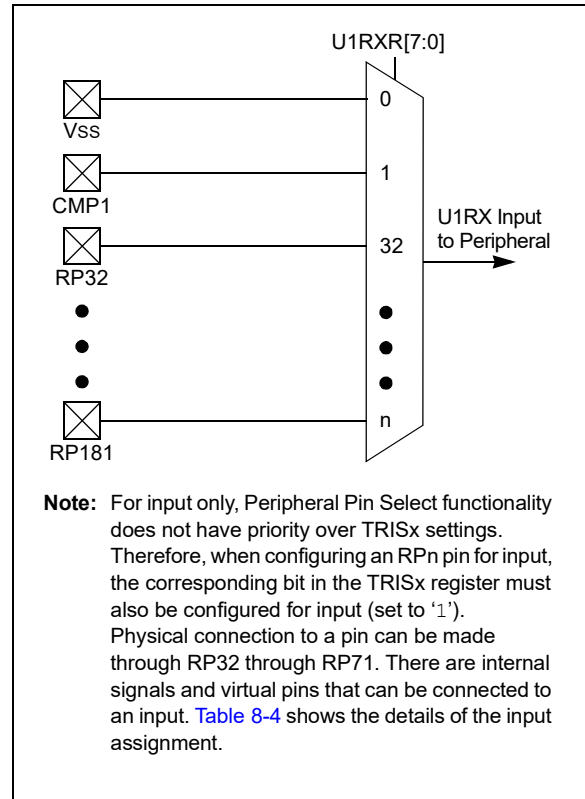
- Input Functions: U1RX,  $\overline{U1CTS}$
- Output Functions: U1TX,  $\overline{U1RTS}$

# dsPIC33CK256MP508 FAMILY

**EXAMPLE 8-1: CONFIGURING UART1 INPUT AND OUTPUT FUNCTIONS**

```
//
*****
// Unlock Registers
//*****
_builtin_write_RPCON(0x0000);
//*****
// Configure Input Functions (See Table 8-5)
// Assign U1Rx To Pin RP35
//*****
_U1RXR = 35;
// Assign U1CTS To Pin RP36
//*****
_U1CTSR = 36;
//*****
// Configure Output Functions (See Table 8-7)
//*****
// Assign U1Tx To Pin RP37
//*****
_RP37R = 1;
//*****
// Assign U1RTS To Pin RP38
//*****
_RP38R = 2;
//*****
// Lock Registers
//*****
_builtin_write_RPCON(0x0800);
```

**FIGURE 8-2: REMAPPABLE INPUT FOR U1RX**



# dsPIC33CK256MP508 FAMILY

**TABLE 8-4: REMAPPABLE PIN INPUTS**

RPINRx[15:8] or RPINRx[7:0]	Function	Available on Ports
0	Vss	Internal
1	Comparator 1	Internal
2	Comparator 2	Internal
3	Comparator 3	Internal
4-5	RP4-RP5	Reserved
6	PTG Trigger 26	Internal
7	PTG Trigger 27	Internal
8-10	RP8-RP10	Reserved
11	PWM Event Out C	Internal
12	PWM Event Out D	Internal
13	PWM Event Out E	Internal
14-31	RP14-RP31	Reserved
32	RP32	Port Pin RB0
33	RP33	Port Pin RB1
34	RP34	Port Pin RB2
35	RP35	Port Pin RB3
36	RP36	Port Pin RB4
37	RP37	Port Pin RB5
38	RP38	Port Pin RB6
39	RP39	Port Pin RB7
40	RP40	Port Pin RB8
41	RP41	Port Pin RB9
42	RP42	Port Pin RB10
43	RP43	Port Pin RB11
44	RP44	Port Pin RB12
45	RP45	Port Pin RB13
46	RP46	Port Pin RB14
47	RP47	Port Pin RB15
48	RP48	Port Pin RC0
49	RP49	Port Pin RC1
50	RP50	Port Pin RC2
51	RP51	Port Pin RC3
52	RP52	Port Pin RC4
53	RP53	Port Pin RC5
54	RP54	Port Pin RC6
55	RP55	Port Pin RC7
56	RP56	Port Pin RC8
57	RP57	Port Pin RC9
58	RP58	Port Pin RC10
59	RP59	Port Pin RC11
60	RP60	Port Pin RC12
61	RP61	Port Pin RC13
62	RP62	Port Pin RC14

# dsPIC33CK256MP508 FAMILY

**TABLE 8-4: REMAPPABLE PIN INPUTS (CONTINUED)**

RPINRx[15:8] or RPINRx[7:0]	Function	Available on Ports
63	RP63	Port Pin RC15
64	RP64	Port Pin RD0
65	RP65	Port Pin RD1
66	RP66	Port Pin RD2
67	RP67	Port Pin RD3
68	RP68	Port Pin RD4
69	RP69	Port Pin RD5
70	RP70	Port Pin RD6
71	RP71	Port Pin RD7
72	RP72	Port Pin RD8
73	RP73	Port Pin RD9
74	RP74	Port Pin RD10
75	RP75	Port Pin RD11
76	RP76	Port Pin RD12
77	RP77	Port Pin RD13
78	RP78	Port Pin RD14
79	RP79	Port Pin RD15
80-163	RP80-RP163	Reserved
164	DAC3 pwm_req_on	Internal
165	DAC3 pwm_req_off	Internal
166	DAC2 pwm_req_on	Internal
167	DAC2 pwm_req_off	Internal
168	DAC1 pwm_req_on	Internal
169	DAC1 pwm_req_off	Internal
170-175	RP170-RP175	Reserved
176	RP176	Virtual RPV0
177	RP177	Virtual RPV1
178	RP178	Virtual RPV2
179	RP179	Virtual RPV3
180	RP180	Virtual RPV4
181	RP181	Virtual RPV5

## 8.5.6 VIRTUAL CONNECTIONS

The dsPIC33CK256MP508 devices support six virtual RPn pins (RP176-RP181), which are identical in functionality to all other RPn pins, with the exception of pinouts. These six pins are internal to the devices and are not connected to a physical device pin.

These pins provide a simple way for inter-peripheral connection without utilizing a physical pin. For example, the output of the analog comparator can be connected to RP176 and the PWM Fault input can be configured for RP176 as well. This configuration allows the analog comparator to trigger PWM Faults without the use of an actual physical pin on the device.

# dsPIC33CK256MP508 FAMILY

**TABLE 8-5: SELECTABLE INPUT SOURCES (MAPS INPUT TO FUNCTION)**

Input Name <sup>(1)</sup>	Function Name	Register	Register Bits
External Interrupt 1	INT1	RPINR0	INT1R[7:0]
External Interrupt 2	INT2	RPINR1	INT2R[7:0]
External Interrupt 3	INT3	RPINR1	INT3R[7:0]
Timer1 External Clock	T1CK	RPINR2	T1CK[7:0]
SCCP Timer1	TCKI1	RPINR3	TCKI1R[7:0]
SCCP Capture 1	ICM1	RPINR3	ICM1R[7:0]
SCCP Timer2	TCKI2	RPINR4	TCKI2R[7:0]
SCCP Capture 2	ICM2	RPINR4	ICM2R[7:0]
SCCP Timer3	TCKI3	RPINR5	TCKI3R[7:0]
SCCP Capture 3	ICM3	RPINR5	ICM3R[7:0]
SCCP Timer4	TCKI4	RPINR6	TCKI4R[7:0]
SCCP Capture 4	ICM4	RPINR6	ICM4R[7:0]
SCCP Timer5	TCKI5	RPINR7	TCKI5R[7:0]
SCCP Capture 5	ICM5	RPINR7	ICM5R[7:0]
SCCP Timer6	TCKI6	RPINR8	TCKI6R[7:0]
SCCP Capture 6	ICM6	RPINR8	ICM6R[7:0]
SCCP Timer7	TCKI7	RPINR9	TCKI7R[7:0]
SCCP Capture 7	ICM7	RPINR9	ICM7R[7:0]
SCCP Timer8	TCKI8	RPINR10	TCKI8R[7:0]
SCCP Capture 8	ICM8	RPINR10	ICM8R[7:0]
xCCP Fault A	OCFA	RPINR11	OCFAR[7:0]
xCCP Fault B	OCFB	RPINR11	OCFBR[7:0]
PWM PCI 8	PCI8	RPINR12	PCI8R[7:0]
PWM PCI 9	PCI9	RPINR12	PCI9R[7:0]
PWM PCI 10	PCI10	RPINR13	PCI10R[7:0]
PWM PCI 11	PCI11	RPINR13	PCI11R[7:0]
QEI1 Input A	QEIA1	RPINR14	QEIA1R[7:0]
QEI1 Input B	QEIB1	RPINR14	QEIB1R[7:0]
QEI1 Index 1 Input	QEINDX1	RPINR15	QEINDX1R[7:0]
QEI1 Home 1 Input	QEIHOM1	RPINR15	QEIHOM1R[7:0]
QEI2 Input A	QEIA2	RPINR16	QEIA2R[7:0]
QEI2 Input B	QEIB2	RPINR16	QEIB2R[7:0]
QEI2 Index 1 Input	QEINDX2	RPINR17	QEINDX2R[7:0]
QEI2 Home 1 Input	QEIHOM2	RPINR17	QEIHOM2R[7:0]
UART1 Receive	U1RX	RPINR18	U1RXR[7:0]
UART1 Data-Set-Ready	$\overline{U1DSR}$	RPINR18	U1DSRR[7:0]
UART2 Receive	U2RX	RPINR19	U2RXR[7:0]
UART2 Data-Set-Ready	$\overline{U2DSR}$	RPINR19	U2DSRR[7:0]
SPI1 Data Input	SDI1	RPINR20	SDI1R[7:0]
SPI1 Clock Input	SCK1IN	RPINR20	SCK1R[7:0]
SPI1 Client Select	$\overline{SS1}$	RPINR21	SS1R[7:0]
Reference Clock Input	REFOI	RPINR21	REFOIR[7:0]
SPI2 Data Input	SDI2	RPINR22	SDI2R[7:0]

**Note 1:** Unless otherwise noted, all inputs use the Schmitt Trigger input buffers.



# dsPIC33CK256MP508 FAMILY

**TABLE 8-5: SELECTABLE INPUT SOURCES (MAPS INPUT TO FUNCTION) (CONTINUED)**

Input Name <sup>(1)</sup>	Function Name	Register	Register Bits
SPI2 Clock Input	SCK2IN	RPINR22	SCK2R[7:0]
SPI2 Client Select	$\overline{SS2}$	RPINR23	SS2R[7:0]
CAN1 Input	CAN1RX	RPINR26	CAN1RXR[7:0]
UART3 Receive	U3RX	RPINR27	U3RXR[7:0]
UART3 Data-Set-Ready	$\overline{U3DSR}$	RPINR27	U3DSRR[7:0]
SPI3 Data Input	SDI3	RPINR29	SDI3R[7:0]
SPI3 Clock Input	SCK3IN	RPINR29	SCK3R[7:0]
SPI3 Client Select	$\overline{SS3}$	RPINR30	SS3R[7:0]
MCCP Timer9	TCKI9	RPINR32	TCKI9R[7:0]
MCCP Capture 9	ICM9	RPINR33	ICM9R[7:0]
xCCP Fault C	OCFC	RPINR37	OCFCR[7:0]
PWM Input 17	PCI17	RPINR37	PCI17R[7:0]
PWM Input 18	PCI18	RPINR38	PCI18R[7:0]
PWM Input 12	PCI12	RPINR42	PCI12R[7:0]
PWM Input 13	PCI13	RPINR42	PCI13R[7:0]
PWM Input 14	PCI14	RPINR43	PCI14R[7:0]
PWM Input 15	PCI15	RPINR43	PCI15R[7:0]
PWM Input 16	PCI16	RPINR44	PCI16R[7:0]
SENT1 Input	SENT1	RPINR44	SENT1R[7:0]
SENT2 Input	SENT2	RPINR45	SENT2R[7:0]
CLC Input A	CLCINA	RPINR45	CLCINAR[7:0]
CLC Input B	CLCINB	RPINR46	CLCINBR[7:0]
CLC Input C	CLCINC	RPINR46	CLCINCR[7:0]
CLC Input D	CLCIND	RPINR47	CLCINDR[7:0]
ADC Trigger Input (ADTRIG31)	ADCTRG	RPINR47	ADCTRGR[7:0]
xCCP Fault D	OCFD	RPINR48	OCFDR[7:0]
UART1 Clear-to-Send	$\overline{U1CTS}$	RPINR48	U1CTSR[7:0]
UART2 Clear-to-Send	$\overline{U2CTS}$	RPINR49	U2CTSR[7:0]
UART3 Clear-to-Send	$\overline{U3CTS}$	RPINR49	U3CTSR[7:0]

**Note 1:** Unless otherwise noted, all inputs use the Schmitt Trigger input buffers.

# dsPIC33CK256MP508 FAMILY

## 8.5.7 OUTPUT MAPPING

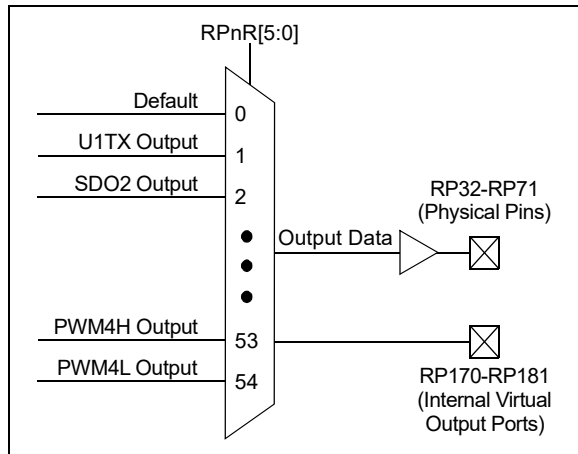
In contrast to inputs, the outputs of the Peripheral Pin Select options are mapped on the basis of the pin. In this case, a control register associated with a particular pin dictates the peripheral output to be mapped. The RPORx registers are used to control output mapping. Each register contains sets of 6-bit fields, with each set associated with one RPn pin (see [Register 8-54](#) through [Register 8-80](#)). The value of the bit field corresponds to one of the peripherals and that peripheral's output is mapped to the pin (see [Table 8-7](#) and [Figure 8-3](#)).

A null output is associated with the output register Reset value of '0'. This is done to ensure that remappable outputs remain disconnected from all output pins by default.

## 8.5.8 MAPPING LIMITATIONS

The control schema of the peripheral select pins is not limited to a small range of fixed peripheral configurations. There are no mutual or hardware-enforced lockouts between any of the peripheral mapping SFRs. Literally, any combination of peripheral mappings, across any or all of the RPn pins, is possible. This includes both many-to-one and one-to-many mappings of peripheral inputs, and outputs to pins. While such mappings may be technically possible from a configuration point of view, they may not be supportable from an electrical point of view (see [Table 8-6](#)).

**FIGURE 8-3: MULTIPLEXING REMAPPABLE OUTPUTS FOR RPn**



**Note 1:** There are six virtual output ports which are not connected to any I/O ports (RP176-RP181). These virtual ports can be accessed by RPOR20, RPOR21 and RPOR22.

# dsPIC33CK256MP508 FAMILY

**TABLE 8-6: REMAPPABLE OUTPUT PIN REGISTERS**

Register	RP Pin	I/O Port
RPOR0[5:0]	RP32	Port Pin RB0
RPOR0[13:8]	RP33	Port Pin RB1
RPOR1[5:0]	RP34	Port Pin RB2
RPOR1[13:8]	RP35	Port Pin RB3
RPOR2[5:0]	RP36	Port Pin RB4
RPOR2[13:8]	RP37	Port Pin RB5
RPOR3[5:0]	RP38	Port Pin RB6
RPOR3[13:8]	RP39	Port Pin RB7
RPOR4[5:0]	RP40	Port Pin RB8
RPOR4[13:8]	RP41	Port Pin RB9
RPOR5[5:0]	RP42	Port Pin RB10
RPOR5[13:8]	RP43	Port Pin RB11
RPOR6[5:0]	RP44	Port Pin RB12
RPOR6[13:8]	RP45	Port Pin RB13
RPOR7[5:0]	RP46	Port Pin RB14
RPOR7[13:8]	RP47	Port Pin RB15
RPOR8[5:0] <sup>(1)</sup>	RP48	Port Pin RC0
RPOR8[13:8] <sup>(1)</sup>	RP49	Port Pin RC1
RPOR9[5:0] <sup>(1)</sup>	RP50	Port Pin RC2
RPOR9[13:8] <sup>(1)</sup>	RP51	Port Pin RC3
RPOR10[5:0] <sup>(1)</sup>	RP52	Port Pin RC4
RPOR10[13:8] <sup>(1)</sup>	RP53	Port Pin RC5
RPOR11[5:0] <sup>(1)</sup>	RP54	Port Pin RC6
RPOR11[13:8] <sup>(1)</sup>	RP55	Port Pin RC7
RPOR12[5:0] <sup>(1)</sup>	RP56	Port Pin RC8
RPOR12[13:8] <sup>(1)</sup>	RP57	Port Pin RC9
RPOR13[5:0] <sup>(1)</sup>	RP58	Port Pin RC10
RPOR13[13:8] <sup>(1)</sup>	RP59	Port Pin RC11
RPOR14[5:0] <sup>(1)</sup>	RP60	Port Pin RC12
RPOR14[13:8] <sup>(1)</sup>	RP61	Port Pin RC13
RPOR15[5:0] <sup>(1)</sup>	RP62	Port Pin RC14
RPOR15[13:8] <sup>(1)</sup>	RP63	Port Pin RC15
RPOR16[5:0] <sup>(1)</sup>	RP64	Port Pin RD0
RPOR16[13:8] <sup>(1)</sup>	RP65	Port Pin RD1
RPOR17[5:0] <sup>(1)</sup>	RP66	Port Pin RD2
RPOR17[13:8] <sup>(1)</sup>	RP67	Port Pin RD3
RPOR18[5:0] <sup>(1)</sup>	RP68	Port Pin RD4
RPOR18[13:8] <sup>(1)</sup>	RP69	Port Pin RD5
RPOR19[5:0] <sup>(1)</sup>	RP70	Port Pin RD6
RPOR19[13:8] <sup>(1)</sup>	RP71	Port Pin RD7
RPOR20[5:0] <sup>(1)</sup>	RP72	Port Pin RD8
RPOR20[13:8] <sup>(1)</sup>	RP73	Port Pin RD9
RPOR21[5:0] <sup>(1)</sup>	RP74	Port Pin D10

**Note 1:** Availability is dependent on supported I/O ports. Refer to [Table 8-1](#) for availability on device variants.

# dsPIC33CK256MP508 FAMILY

TABLE 8-6: REMAPPABLE OUTPUT PIN REGISTERS (CONTINUED)

Register	RP Pin	I/O Port
RPOR21[13:8] <sup>(1)</sup>	RP75	Port Pin RD11
RPOR22[5:0] <sup>(1)</sup>	RP76	Port Pin RD12
RPOR22[13:8] <sup>(1)</sup>	RP77	Port Pin RD13
RPOR23[5:0] <sup>(1)</sup>	RP78	Port Pin RD14
RPOR23[13:8] <sup>(1)</sup>	RP79	Port Pin RD15
	RP80-RP175	Reserved
RPOR24[5:0]	RP176	Virtual Pin RPV0
RPOR24[13:8]	RP177	Virtual Pin RPV1
RPOR25[5:0]	RP178	Virtual Pin RPV2
RPOR25[13:8]	RP179	Virtual Pin RPV3
RPOR26[5:0]	RP180	Virtual Pin RPV4
RPOR26[13:8]	RP181	Virtual Pin RPV5

**Note 1:** Availability is dependent on supported I/O ports. Refer to [Table 8-1](#) for availability on device variants.

# dsPIC33CK256MP508 FAMILY

**TABLE 8-7: OUTPUT SELECTION FOR REMAPPABLE PINS (RPn)**

Function	RPnR[5:0]	Output Name
Default PORT	0	RPn tied to Default Pin
U1TX	1	RPn tied to UART1 Transmit
$\overline{\text{U1RTS}}$	2	RPn tied to UART1 Request-to-Send
U2TX	3	RPn tied to UART2 Transmit
$\overline{\text{U2RTS}}$	4	RPn tied to UART2 Request-to-Send
SDO1	5	RPn tied to SPI1 Data Output
SCK1	6	RPn tied to SPI1 Clock Output
$\overline{\text{SS1}}$	7	RPn tied to SPI1 Client Select
SDO2	8	RPn tied to SPI2 Data Output
SCK2	9	RPn tied to SPI2 Clock Output
$\overline{\text{SS2}}$	10	RPn tied to SPI2 Client Select
SDO3	11	RPn tied to SPI3 Data Output
SCK3	12	RPn tied to SPI3 Clock Output
$\overline{\text{SS3}}$	13	RPn tied to SPI3 Client Select
REFCLKO	14	RPn tied to Reference Clock Output
OCM1	15	RPn tied to SCCP1 Output
OCM2	16	RPn tied to SCCP2 Output
OCM3	17	RPn tied to SCCP3 Output
OCM4	18	RPn tied to SCCP4 Output
OCM5	19	RPn tied to SCCP5 Output
OCM6	20	RPn tied to SCCP6 Output
CAN1TX	21	RPn tied to CAN1 Transmit
CMP1	23	RPn tied to Comparator 1 Output
CMP2	24	RPn tied to Comparator 2 Output
CMP3	25	RPn tied to Comparator 3 Output
U3TX	27	RPn tied to UART3 Transmit
$\overline{\text{U3RTS}}$	28	RPn tied to UART3 Request-to-Send
PWM4H	34	RPn tied to PWM4H Output
PWM4L	35	RPn tied to PWM4L Output
PWMEA	36	RPn tied to PWM Event A Output
PWMEB	37	RPn tied to PWM Event B Output
QEICMP1	38	RPn tied to QEI1 Comparator Output
QEICMP2	39	RPn tied to QEI2 Comparator Output
CLC1OUT	40	RPn tied to CLC1 Output
CLC2OUT	41	RPn tied to CLC2 Output
OCM7	42	RPn tied to SCCP7 Output
OCM8	43	RPn tied to SCCP8 Output
PWMEC	44	RPn tied to PWM Event C Output
PWMEC	45	RPn tied to PWM Event D Output
PTGTRG24	46	PTG Trigger Output 24
PTGTRG25	47	PTG Trigger Output 25
SENT1OUT	48	RPn tied to SENT1 Output
SENT2OUT	49	RPn tied to SENT2 Output

# dsPIC33CK256MP508 FAMILY

---

---

**TABLE 8-7: OUTPUT SELECTION FOR REMAPPABLE PINS (RPn) (CONTINUED)**

Function	RPnR[5:0]	Output Name
MCCP9A	50	RPn tied to MCCP9 Output A
MCCP9B	51	RPn tied to MCCP9 Output B
MCCP9C	52	RPn tied to MCCP9 Output C
MCCP9D	53	RPn tied to MCCP9 Output D
MCCP9E	54	RPn tied to MCCP9 Output E
MCCP9F	55	RPn tied to MCCP9 Output F
CLC3OUT	59	RPn tied to CLC4 Output
CLC4OUT	60	RPn tied to CLC4 Output
U1DTR	61	RPn tied to UART1 DTR
U2DTR	62	RPn tied to UART2 DTR
U3DTR	63	RPn tied to UART3 DTR

## 8.5.9 I/O HELPFUL TIPS

1. In some cases, certain pins, as defined in [Table 33-16](#) under “Injection Current”, have internal protection diodes to VDD and VSS. The term, “Injection Current”, is also referred to as “Clamp Current”. On designated pins, with sufficient external current-limiting precautions by the user, I/O pin input voltages are allowed to be greater or lesser than the data sheet absolute maximum ratings, with respect to the VSS and VDD supplies. Note that when the user application forward biases either of the high or low-side internal input clamp diodes, that the resulting current being injected into the device that is clamped internally by the VDD and VSS power rails, may affect the ADC accuracy by four to six counts.
2. I/O pins that are shared with any analog input pin (i.e., ANx) are always analog pins, by default, after any Reset. Consequently, configuring a pin as an analog input pin automatically disables the digital input pin buffer and any attempt to read the digital input level by reading PORTx or LATx will always return a ‘0’, regardless of the digital logic level on the pin. To use a pin as a digital I/O pin on a shared ANx pin, the user application needs to configure the Analog Select for PORTx registers in the I/O ports module (i.e., ANSELx) by setting the appropriate bit that corresponds to that I/O port pin to a ‘0’.

**Note:** Although it is not possible to use a digital input pin when its analog function is enabled, it is possible to use the digital I/O output function, TRISx = 0x0, while the analog function is also enabled. However, this is not recommended, particularly if the analog input is connected to an external analog voltage source, which would create signal contention between the analog signal and the output pin driver.

3. Most I/O pins have multiple functions. Referring to the device pin diagrams in this data sheet, the priorities of the functions allocated to any pins are indicated by reading the pin name, from left-to-right. The left most function name takes precedence over any function to its right in the naming convention. For example: AN16/T2CK/T7CK/RC1; this indicates that AN16 is the highest priority in this example and will supersede all other functions to its right in the list. Those other functions to its right, even if enabled, would not work as long as any other function to its left was enabled. This rule applies to all of the functions listed for a given pin.
4. Each pin has an internal weak pull-up resistor and pull-down resistor that can be configured using the CNPUs and CNPDx registers, respectively. These resistors eliminate the need for external resistors in certain applications. The internal pull-up is up to  $\sim(VDD - 0.8)$ , not VDD. This value is still above the minimum  $V_{IH}$  of CMOS and TTL devices.
5. When driving LEDs directly, the I/O pin can source or sink more current than what is specified in the  $V_{OH}/I_{OH}$  and  $V_{OL}/I_{OL}$  DC characteristics specification. The respective  $I_{OH}$  and  $I_{OL}$  current rating only applies to maintaining the corresponding output at or above the  $V_{OH}$ , and at or below the  $V_{OL}$  levels. However, for LEDs, unlike digital inputs of an externally connected device, they are not governed by the same minimum  $V_{IH}/V_{IL}$  levels. An I/O pin output can safely sink or source any current less than that listed in the Absolute Maximum Ratings in [Section 33.0 “Electrical Characteristics”](#) of this data sheet. For example:

$$V_{OH} = 2.4v @ I_{OH} = -8 \text{ mA and } V_{DD} = 3.3V$$

The maximum output current sourced by any 8 mA I/O pin = 12 mA.

LED source current < 12 mA is technically permitted.

# dsPIC33CK256MP508 FAMILY

---

6. The Peripheral Pin Select (PPS) pin mapping rules are as follows:

- a) Only one “output” function can be active on a given pin at any time, regardless if it is a dedicated or remappable function (one pin, one output).
- b) It is possible to assign a “remappable output” function to multiple pins and externally short or tie them together for increased current drive.
- c) If any “dedicated output” function is enabled on a pin, it will take precedence over any remappable “output” function.
- d) If any “dedicated digital” (input or output) function is enabled on a pin, any number of “input” remappable functions can be mapped to the same pin.
- e) If any “dedicated analog” function(s) are enabled on a given pin, “digital input(s)” of any kind will all be disabled, although a single “digital output”, at the user’s cautionary discretion, can be enabled and active as long as there is no signal contention with an external analog input signal. For example, it is possible for the ADC to convert the digital output logic level, or to toggle a digital output on a comparator or ADC input, provided there is no external analog input, such as for a built-in self-test.
- f) Any number of “input” remappable functions can be mapped to the same pin(s) at the same time, including to any pin with a single output from either a dedicated or remappable “output”.
- g) The TRISx registers control *only* the digital I/O output buffer. Any other dedicated or remappable active “output” will automatically override the TRISx setting. The TRISx register *does not* control the digital logic “input” buffer. Remappable digital “inputs” do not automatically override TRISx settings, which means that the TRISx bit must be set to input for pins with only remappable input function(s) assigned.
- h) All analog pins are enabled by default after any Reset and the corresponding digital input buffer on the pin has been disabled. Only the Analog Select for PORTx (ANSELx) registers control the digital input buffer, *not* the TRISx register. The user must disable the analog function on a pin using the Analog Select for PORTx registers in order to use any “digital input(s)” on a corresponding pin, no exceptions.

## 8.5.10 I/O PORTS RESOURCES

Many useful resources are provided on the main product page of the Microchip website for the devices listed in this data sheet. This product page contains the latest updates and additional information.

### 8.5.10.1 Key Resources

- “**I/O Ports with Edge Detect**” (DS70005322) in the “*dsPIC33/PIC24 Family Reference Manual*”
- Code Samples
- Application Notes
- Software Libraries
- Webinars
- All Related “*dsPIC33/PIC24 Family Reference Manual*” Sections
- Development Tools



**TABLE 8-8: PORTA REGISTER SUMMARY**

Register	Bit 15	Bit 14	Bit 13	Bit 12	Bit 11	Bit 10	Bit 9	Bit 8	Bit 7	Bit 6	Bit 5	Bit 4	Bit 3	Bit 2	Bit 1	Bit 0
ANSELA	—	—	—	—	—	—	—	—	—	—	—	ANSELA[4:0]				
TRISA	—	—	—	—	—	—	—	—	—	—	—	TRISA[4:0]				
PORTA	—	—	—	—	—	—	—	—	—	—	—	RA[4:0]				
LATA	—	—	—	—	—	—	—	—	—	—	—	LATA[4:0]				
ODCA	—	—	—	—	—	—	—	—	—	—	—	ODCA[4:0]				
CNPUA	—	—	—	—	—	—	—	—	—	—	—	CNPUA[4:0]				
CNPDA	—	—	—	—	—	—	—	—	—	—	—	CNPDA[4:0]				
CNCONA	ON	—	—	—	CNSTYLE	—	—	—	—	—	—	—	—	—	—	—
CNEN0A	—	—	—	—	—	—	—	—	—	—	—	CNEN0A[4:0]				
CNSTATA	—	—	—	—	—	—	—	—	—	—	—	CNSTATA[4:0]				
CNEN1A	—	—	—	—	—	—	—	—	—	—	—	CNEN1A[4:0]				
CNFA	—	—	—	—	—	—	—	—	—	—	—	CNFA[4:0]				

**TABLE 8-9: PORTB REGISTER SUMMARY**

Register	Bit 15	Bit 14	Bit 13	Bit 12	Bit 11	Bit 10	Bit 9	Bit 8	Bit 7	Bit 6	Bit 5	Bit 4	Bit 3	Bit 2	Bit 1	Bit 0
ANSELB	—	—	—	—	—	—	ANSELB[9:7]			—	—	ANSELB[4:0]				
TRISB								TRISB[15:0]								
PORTB								RB[15:0]								
LATB								LATB[15:0]								
ODCB								ODCB[15:0]								
CNPUB								CNPUB[15:0]								
CNPDB								CNPDB[15:0]								
CNCONB	ON	—	—	—	CNSTYLE	—	—	—	—	—	—	—	—	—	—	—
CNEN0B								CNEN0[15:0]								
CNSTATB								CNSTATB[15:0]								
CNEN1B								CNEN1B[15:0]								
CNFB								CNFB[15:0]								

**TABLE 8-10: PORTC REGISTER SUMMARY**

Register	Bit 15	Bit 14	Bit 13	Bit 12	Bit 11	Bit 10	Bit 9	Bit 8	Bit 7	Bit 6	Bit 5	Bit 4	Bit 3	Bit 2	Bit 1	Bit 0
ANSELC	—	—	—	—	—	—	—	—	ANSELC[7:6]			—	—	ANSELC[3:0]		
TRISC	TRISC[15:0]															
PORTC	RC[15:0]															
LATC	LATC[15:0]															
ODCC	ODCC[15:0]															
CNPUC	CNPUC[15:0]															
CNPDC	CNPDC[15:0]															
CNCONC	ON	—	—	—	CNSTYLE	—	—	—	—	—	—	—	—	—	—	—
CNEN0C	CNEN0C[15:0]															
CNSTATC	CNSTATC[15:0]															
CNEN1C	CNEN1C[15:0]															
CNFC	CNFC[15:0]															

**TABLE 8-11: PORTD REGISTER SUMMARY**

Register	Bit 15	Bit 14	Bit 13	Bit 12	Bit 11	Bit 10	Bit 9	Bit 8	Bit 7	Bit 6	Bit 5	Bit 4	Bit 3	Bit 2	Bit 1	Bit 0
ANSELD	—	—	ANSELD[13]	—	ANSELD[11:10]			—	—	—	—	—	—	—	—	—
TRISD	TRISD[15:0]															
PORTD	RD[15:0]															
LATD	LATD[15:0]															
ODCD	ODCD[15:0]															
CNPUD	CNPUD[15:0]															
CNPDD	CNPDD[15:0]															
CNCOND	ON	—	—	—	CNSTYLE	—	—	—	—	—	—	—	—	—	—	—
CNEN0D	CNEN0D[15:0]															
CNSTATD	CNSTATD[15:0]															
CNEN1D	CNEN1D[15:0]															
CNFD	CNFD[15:0]															

**TABLE 8-12: PORTE REGISTER SUMMARY**

Register	Bit 15	Bit 14	Bit 13	Bit 12	Bit 11	Bit 10	Bit 9	Bit 8	Bit 7	Bit 6	Bit 5	Bit 4	Bit 3	Bit 2	Bit 1	Bit 0
ANSLE	—	—	—	—	—	—	—	—	—	—	—	—	—	—	—	—
TRISE	TRISE[15:0]															
PORTE	RE[15:0]															
LATE	LATE[15:0]															
ODCE	ODCE[15:0]															
CNPUE	CNPUE[15:0]															
CNPDE	CNPDE[15:0]															
CNCONE	ON	—	—	—	CNSTYLE	—	—	—	—	—	—	—	—	—	—	—
CNEN0E	CNEN0E[15:0]															
CNSTATE	CNSTATE[15:0]															
CNEN1E	CNEN1E[15:0]															
CNFE	CNFE[15:0]															

# dsPIC33CK256MP508 FAMILY

## 8.5.11 PERIPHERAL PIN SELECT REGISTERS

### REGISTER 8-13: RPCON: PERIPHERAL REMAPPING CONFIGURATION REGISTER<sup>(1)</sup>

U-0	U-0	U-0	U-0	R/W-0	U-0	U-0	U-0
—	—	—	—	IOLOCK	—	—	—
bit 15							bit 8

U-0	U-0	U-0	U-0	U-0	U-0	U-0	U-0
—	—	—	—	—	—	—	—
bit 7							bit 0

**Legend:**

R = Readable bit                      W = Writable bit                      U = Unimplemented bit, read as '0'  
 -n = Value at POR                      '1' = Bit is set                      '0' = Bit is cleared                      x = Bit is unknown

- bit 15-12      **Unimplemented:** Read as '0'
- bit 11      **IOLOCK:** Peripheral Remapping Register Lock bit  
                     1 = All Peripheral Remapping registers are locked and cannot be written  
                     0 = All Peripheral Remapping registers are unlocked and can be written
- bit 10-0      **Unimplemented:** Read as '0'

**Note 1:** Writing to this register needs an unlock sequence (see [Section 8.5.3 “Controlling Configuration Changes”](#)).

### REGISTER 8-14: RPINR0: PERIPHERAL PIN SELECT INPUT REGISTER

R/W-0	R/W-0	R/W-0	R/W-0	R/W-0	R/W-0	R/W-0	R/W-0
INT1R7	INT1R6	INT1R5	INT1R4	INT1R3	INT1R2	INT1R1	INT1R0
bit 15							bit 8

U-0	U-0	U-0	U-0	U-0	U-0	U-0	U-0
—	—	—	—	—	—	—	—
bit 7							bit 0

**Legend:**

R = Readable bit                      W = Writable bit                      U = Unimplemented bit, read as '0'  
 -n = Value at POR                      '1' = Bit is set                      '0' = Bit is cleared                      x = Bit is unknown

- bit 15-8      **INT1R[7:0]:** Assign External Interrupt 1 (INT1) to the Corresponding RPn Pin bits  
                     See [Table 8-4](#).
- bit 7-0      **Unimplemented:** Read as '0'

# dsPIC33CK256MP508 FAMILY

## REGISTER 8-15: RPINR1: PERIPHERAL PIN SELECT INPUT REGISTER 1

R/W-0	R/W-0	R/W-0	R/W-0	R/W-0	R/W-0	R/W-0	R/W-0
INT3R7	INT3R6	INT3R5	INT3R4	INT3R3	INT3R2	INT3R1	INT3R0
bit 15							bit 8

R/W-0	R/W-0	R/W-0	R/W-0	R/W-0	R/W-0	R/W-0	R/W-0
INT2R7	INT2R6	INT2R5	INT2R4	INT2R3	INT2R2	INT2R1	INT2R0
bit 7							bit 0

### Legend:

R = Readable bit                      W = Writable bit                      U = Unimplemented bit, read as '0'  
 -n = Value at POR                      '1' = Bit is set                      '0' = Bit is cleared                      x = Bit is unknown

bit 15-8            **INT3R[7:0]:** Assign External Interrupt 3 (INT3) to the Corresponding RPn Pin bits  
 See [Table 8-4](#).

bit 7-0            **INT2R[7:0]:** Assign External Interrupt 2 (INT2) to the Corresponding RPn Pin bits  
 See [Table 8-4](#).

## REGISTER 8-16: RPINR2: PERIPHERAL PIN SELECT INPUT REGISTER 2

R/W-0	R/W-0	R/W-0	R/W-0	R/W-0	R/W-0	R/W-0	R/W-0
T1CKR7	T1CKR6	T1CKR5	T1CKR4	T1CKR3	T1CKR2	T1CKR1	T1CKR0
bit 15							bit 8

U-0	U-0	U-0	U-0	U-0	U-0	U-0	U-0
—	—	—	—	—	—	—	—
bit 7							bit 0

### Legend:

R = Readable bit                      W = Writable bit                      U = Unimplemented bit, read as '0'  
 -n = Value at POR                      '1' = Bit is set                      '0' = Bit is cleared                      x = Bit is unknown

bit 15-8            **T1CKR[7:0]:** Assign Timer1 External Clock (T1CK) to the Corresponding RPn Pin bits  
 See [Table 8-4](#).

bit 7-0            **Unimplemented:** Read as '0'

# dsPIC33CK256MP508 FAMILY

## REGISTER 8-17: RPINR3: PERIPHERAL PIN SELECT INPUT REGISTER 3

R/W-0	R/W-0	R/W-0	R/W-0	R/W-0	R/W-0	R/W-0	R/W-0
ICM1R7	ICM1R6	ICM1R5	ICM1R4	ICM1R3	ICM1R2	ICM1R1	ICM1R0
bit 15							bit 8

R/W-0	R/W-0	R/W-0	R/W-0	R/W-0	R/W-0	R/W-0	R/W-0
TCKI1R7	TCKI1R6	TCKI1R5	TCKI1R4	TCKI1R3	TCKI1R2	TCKI1R1	TCKI1R0
bit 7							bit 0

### Legend:

R = Readable bit                      W = Writable bit                      U = Unimplemented bit, read as '0'  
 -n = Value at POR                      '1' = Bit is set                      '0' = Bit is cleared                      x = Bit is unknown

bit 15-8            **ICM1R[7:0]:** Assign SCCP Capture 1 (ICM1) Input to the Corresponding RPn Pin bits  
 See [Table 8-4](#).

bit 7-0            **TCKI1[7:0]:** Assign SCCP Timer1 (TCKI1) Input to the Corresponding RPn Pin bits  
 See [Table 8-4](#).

## REGISTER 8-18: RPINR4: PERIPHERAL PIN SELECT INPUT REGISTER 4

R/W-0	R/W-0	R/W-0	R/W-0	R/W-0	R/W-0	R/W-0	R/W-0
ICM2R7	ICM2R6	ICM2R5	ICM2R4	ICM2R3	ICM2R2	ICM2R1	ICM2R0
bit 15							bit 8

R/W-0	R/W-0	R/W-0	R/W-0	R/W-0	R/W-0	R/W-0	R/W-0
TCKI2R7	TCKI2R6	TCKI2R5	TCKI2R4	TCKI2R3	TCKI2R2	TCKI2R1	TCKI2R0
bit 7							bit 0

### Legend:

R = Readable bit                      W = Writable bit                      U = Unimplemented bit, read as '0'  
 -n = Value at POR                      '1' = Bit is set                      '0' = Bit is cleared                      x = Bit is unknown

bit 15-8            **ICM2R[7:0]:** Assign SCCP Capture 2 (ICM2) Input to the Corresponding RPn Pin bits  
 See [Table 8-4](#).

bit 7-0            **TCKI2R[7:0]:** Assign SCCP Timer2 (TCKI2) Input to the Corresponding RPn Pin bits  
 See [Table 8-4](#).

# dsPIC33CK256MP508 FAMILY

## REGISTER 8-19: RPINR5: PERIPHERAL PIN SELECT INPUT REGISTER 5

R/W-0	R/W-0	R/W-0	R/W-0	R/W-0	R/W-0	R/W-0	R/W-0
ICM3R7	ICM3R6	ICM3R5	ICM3R4	ICM3R3	ICM3R2	ICM3R1	ICM3R0
bit 15							bit 8

R/W-0	R/W-0	R/W-0	R/W-0	R/W-0	R/W-0	R/W-0	R/W-0
TCKI3R7	TCKI3R6	TCKI3R5	TCKI3R4	TCKI3R3	TCKI3R2	TCKI3R1	TCKI3R0
bit 7							bit 0

### Legend:

R = Readable bit                      W = Writable bit                      U = Unimplemented bit, read as '0'  
 -n = Value at POR                      '1' = Bit is set                      '0' = Bit is cleared                      x = Bit is unknown

bit 15-8                      **ICM3R[7:0]:** Assign SCCP Capture 3 (ICM3) Input to the Corresponding RPn Pin bits  
 See [Table 8-4](#).

bit 7-0                      **TCKI3R[7:0]:** Assign SCCP Timer3 (TCKI3) Input to the Corresponding RPn Pin bits  
 See [Table 8-4](#).

## REGISTER 8-20: RPINR6: PERIPHERAL PIN SELECT INPUT REGISTER 6

R/W-0	R/W-0	R/W-0	R/W-0	R/W-0	R/W-0	R/W-0	R/W-0
ICM4R7	ICM4R6	ICM4R5	ICM4R4	ICM4R3	ICM4R2	ICM4R1	ICM4R0
bit 15							bit 8

R/W-0	R/W-0	R/W-0	R/W-0	R/W-0	R/W-0	R/W-0	R/W-0
TCKI4R7	TCKI4R6	TCKI4R5	TCKI4R4	TCKI4R3	TCKI4R2	TCKI4R1	TCKI4R0
bit 7							bit 0

### Legend:

R = Readable bit                      W = Writable bit                      U = Unimplemented bit, read as '0'  
 -n = Value at POR                      '1' = Bit is set                      '0' = Bit is cleared                      x = Bit is unknown

bit 15-8                      **ICM4R[7:0]:** Assign SCCP Capture 4 (ICM4) Input to the Corresponding RPn Pin bits  
 See [Table 8-4](#).

bit 7-0                      **TCKI4R[7:0]:** Assign SCCP Timer4 (TCKI4) Input to the Corresponding RPn Pin bits  
 See [Table 8-4](#).

# dsPIC33CK256MP508 FAMILY

## REGISTER 8-21: RPINR7: PERIPHERAL PIN SELECT INPUT REGISTER 7

R/W-0	R/W-0	R/W-0	R/W-0	R/W-0	R/W-0	R/W-0	R/W-0
ICM5R7	ICM5R6	ICM5R5	ICM5R4	ICM5R3	ICM5R2	ICM5R1	ICM5R0
bit 15							bit 8

R/W-0	R/W-0	R/W-0	R/W-0	R/W-0	R/W-0	R/W-0	R/W-0
TCKI5R7	TCKI5R6	TCKI5R5	TCKI5R4	TCKI5R3	TCKI5R2	TCKI5R1	TCKI5R0
bit 7							bit 0

**Legend:**

R = Readable bit                      W = Writable bit                      U = Unimplemented bit, read as '0'  
 -n = Value at POR                      '1' = Bit is set                      '0' = Bit is cleared                      x = Bit is unknown

bit 15-8            **ICM5R[7:0]:** Assign SCCP Capture 5 (ICM5) Input to the Corresponding RPn Pin bits  
 See [Table 8-4](#).

bit 7-0            **TCKI5R[7:0]:** Assign SCCP Timer5 (TCKI5) Input to the Corresponding RPn Pin bits  
 See [Table 8-4](#).

## REGISTER 8-22: RPINR8: PERIPHERAL PIN SELECT INPUT REGISTER 8

R/W-0	R/W-0	R/W-0	R/W-0	R/W-0	R/W-0	R/W-0	R/W-0
ICM6R7	ICM6R6	ICM6R5	ICM6R4	ICM6R3	ICM6R2	ICM6R1	ICM6R0
bit 15							bit 8

R/W-0	R/W-0	R/W-0	R/W-0	R/W-0	R/W-0	R/W-0	R/W-0
TCKI6R7	TCKI6R6	TCKI6R5	TCKI6R4	TCKI6R3	TCKI6R2	TCKI6R1	TCKI6R0
bit 7							bit 0

**Legend:**

R = Readable bit                      W = Writable bit                      U = Unimplemented bit, read as '0'  
 -n = Value at POR                      '1' = Bit is set                      '0' = Bit is cleared                      x = Bit is unknown

bit 15-8            **ICM6R[7:0]:** Assign SCCP Capture 6 (ICM6) Input to the Corresponding RPn Pin bits  
 See [Table 8-4](#).

bit 7-0            **TCKI6R[7:0]:** Assign SCCP Timer6 (TCKI6) Input to the Corresponding RPn Pin bits  
 See [Table 8-4](#).



# dsPIC33CK256MP508 FAMILY

## REGISTER 8-23: RPINR9: PERIPHERAL PIN SELECT INPUT REGISTER 9

R/W-0	R/W-0	R/W-0	R/W-0	R/W-0	R/W-0	R/W-0	R/W-0
ICM7R7	ICM7R6	ICM7R5	ICM7R4	ICM7R3	ICM7R2	ICM7R1	ICM7R0
bit 15							bit 8

R/W-0	R/W-0	R/W-0	R/W-0	R/W-0	R/W-0	R/W-0	R/W-0
TCKI7R7	TCKI7R6	TCKI7R5	TCKI7R4	TCKI7R3	TCKI7R2	TCKI7R1	TCKI7R0
bit 7							bit 0

### Legend:

R = Readable bit                      W = Writable bit                      U = Unimplemented bit, read as '0'  
 -n = Value at POR                      '1' = Bit is set                      '0' = Bit is cleared                      x = Bit is unknown

bit 15-8            **ICM7R[7:0]:** Assign SCCP Capture 7 (ICM7) Input to the Corresponding RPn Pin bits  
 See [Table 8-4](#).

bit 7-0            **TCKI7R[7:0]:** Assign SCCP Timer7 (TCKI7) Input to the Corresponding RPn Pin bits  
 See [Table 8-4](#).

## REGISTER 8-24: RPINR10: PERIPHERAL PIN SELECT INPUT REGISTER 10

R/W-0	R/W-0	R/W-0	R/W-0	R/W-0	R/W-0	R/W-0	R/W-0
ICM8R7	ICM8R6	ICM8R5	ICM8R4	ICM8R3	ICM8R2	ICM8R1	ICM8R0
bit 15							bit 8

R/W-0	R/W-0	R/W-0	R/W-0	R/W-0	R/W-0	R/W-0	R/W-0
TCKI8R7	TCKI8R6	TCKI8R5	TCKI8R4	TCKI8R3	TCKI8R2	TCKI8R1	TCKI8R0
bit 7							bit 0

### Legend:

R = Readable bit                      W = Writable bit                      U = Unimplemented bit, read as '0'  
 -n = Value at POR                      '1' = Bit is set                      '0' = Bit is cleared                      x = Bit is unknown

bit 15-8            **ICM8R[7:0]:** Assign SCCP Capture 8 (ICM8) Input to the Corresponding RPn Pin bits  
 See [Table 8-4](#).

bit 7-0            **TCKI8R[7:0]:** Assign SCCP Timer8 (TCKI8) Input to the Corresponding RPn Pin bits  
 See [Table 8-4](#).

# dsPIC33CK256MP508 FAMILY

## REGISTER 8-25: RPINR11: PERIPHERAL PIN SELECT INPUT REGISTER 11

R/W-0	R/W-0	R/W-0	R/W-0	R/W-0	R/W-0	R/W-0	R/W-0
OCFBR7	OCFBR6	OCFBR5	OCFBR4	OCFBR3	OCFBR2	OCFBR1	OCFBR0
bit 15							bit 8

R/W-0	R/W-0	R/W-0	R/W-0	R/W-0	R/W-0	R/W-0	R/W-0
OCFAR7	OCFAR6	OCFAR5	OCFAR4	OCFAR3	OCFAR2	OCFAR1	OCFAR0
bit 7							bit 0

**Legend:**

R = Readable bit                      W = Writable bit                      U = Unimplemented bit, read as '0'  
 -n = Value at POR                      '1' = Bit is set                      '0' = Bit is cleared                      x = Bit is unknown

bit 15-8            **OCFBR[7:0]:** Assign SCCP Fault B (OCFB) Input to the Corresponding RPn Pin bits  
 See [Table 8-4](#).

bit 7-0             **OCFAR[7:0]:** Assign SCCP Fault A (OCFA) Input to the Corresponding RPn Pin bits  
 See [Table 8-4](#).

## REGISTER 8-26: RPINR12: PERIPHERAL PIN SELECT INPUT REGISTER 12

R/W-0	R/W-0	R/W-0	R/W-0	R/W-0	R/W-0	R/W-0	R/W-0
PCI9R7	PCI9R6	PCI9R5	PCI9R4	PCI9R3	PCI9R2	PCI9R1	PCI9R0
bit 15							bit 8

R/W-0	R/W-0	R/W-0	R/W-0	R/W-0	R/W-0	R/W-0	R/W-0
PCI8R7	PCI8R6	PCI8R5	PCI8R4	PCI8R3	PCI8R2	PCI8R1	PCI8R0
bit 7							bit 0

**Legend:**

R = Readable bit                      W = Writable bit                      U = Unimplemented bit, read as '0'  
 -n = Value at POR                      '1' = Bit is set                      '0' = Bit is cleared                      x = Bit is unknown

bit 15-8            **PCI9R[7:0]:** Assign PWM Input 9 (PCI9) to the Corresponding RPn Pin bits  
 See [Table 8-4](#).

bit 7-0             **PCI8R[7:0]:** Assign PWM Input 8 (PCI8) to the Corresponding RPn Pin bits  
 See [Table 8-4](#).

# dsPIC33CK256MP508 FAMILY

## REGISTER 8-27: RPINR13: PERIPHERAL PIN SELECT INPUT REGISTER 13

R/W-0	R/W-0	R/W-0	R/W-0	R/W-0	R/W-0	R/W-0	R/W-0
PCI11R7	PCI11R6	PCI11R5	PCI11R4	PCI11R3	PCI11R2	PCI11R1	PCI11R0
bit 15							bit 8

R/W-0	R/W-0	R/W-0	R/W-0	R/W-0	R/W-0	R/W-0	R/W-0
PCI10R7	PCI10R6	PCI10R5	PCI10R4	PCI10R3	PCI10R2	PCI10R1	PCI10R0
bit 7							bit 0

### Legend:

R = Readable bit                      W = Writable bit                      U = Unimplemented bit, read as '0'  
 -n = Value at POR                      '1' = Bit is set                      '0' = Bit is cleared                      x = Bit is unknown

bit 15-8                      **PCI11R[7:0]**: Assign PWM Input 11 (PCI11) to the Corresponding RPn Pin bits  
 See [Table 8-4](#).

bit 7-0                      **PCI10R[7:0]**: Assign PWM Input 10 (PCI10) to the Corresponding RPn Pin bits  
 See [Table 8-4](#).

## REGISTER 8-28: RPINR14: PERIPHERAL PIN SELECT INPUT REGISTER 14

R/W-0	R/W-0	R/W-0	R/W-0	R/W-0	R/W-0	R/W-0	R/W-0
QEIB1R7	QEIB1R6	QEIB1R5	QEIB1R4	QEIB1R3	QEIB1R2	QEIB1R1	QEIB1R0
bit 15							bit 8

R/W-0	R/W-0	R/W-0	R/W-0	R/W-0	R/W-0	R/W-0	R/W-0
QEIA1R7	QEIA1R6	QEIA1R5	QEIA1R4	QEIA1R3	QEIA1R2	QEIA1R1	QEIA1R0
bit 7							bit 0

### Legend:

R = Readable bit                      W = Writable bit                      U = Unimplemented bit, read as '0'  
 -n = Value at POR                      '1' = Bit is set                      '0' = Bit is cleared                      x = Bit is unknown

bit 15-8                      **QEIB1R[7:0]**: Assign QEI1 Input B (QEIB1) to the Corresponding RPn Pin bits  
 See [Table 8-4](#).

bit 7-0                      **QEIA1R[7:0]**: Assign QEI1 Input A (QEIA1) to the Corresponding RPn Pin bits  
 See [Table 8-4](#).

# dsPIC33CK256MP508 FAMILY

## REGISTER 8-29: RPINR15: PERIPHERAL PIN SELECT INPUT REGISTER 15

R/W-0	R/W-0	R/W-0	R/W-0	R/W-0	R/W-0	R/W-0	R/W-0
QEIHOM1R7	QEIHOM1R6	QEIHOM1R5	QEIHOM1R4	QEIHOM1R3	QEIHOM1R2	QEIHOM1R1	QEIHOM1R0
bit 15							bit 8

R/W-0	R/W-0	R/W-0	R/W-0	R/W-0	R/W-0	R/W-0	R/W-0
QEINDX1R7	QEINDX1R6	QEINDX1R5	QEINDX1R4	QEINDX1R3	QEINDX1R2	QEINDX1R1	QEINDX1R0
bit 7							bit 0

### Legend:

R = Readable bit                      W = Writable bit                      U = Unimplemented bit, read as '0'  
 -n = Value at POR                      '1' = Bit is set                      '0' = Bit is cleared                      x = Bit is unknown

bit 15-8        **QEIHOM1R[7:0]:** Assign QEI Home 1 Input (QEIHOM1) to the Corresponding RPn Pin bits  
 See [Table 8-4](#).

bit 7-0        **QEINDX1R[7:0]:** Assign QEI Index 1 Input (QEINDX1) to the Corresponding RPn Pin bits  
 See [Table 8-4](#).

## REGISTER 8-30: RPINR16: PERIPHERAL PIN SELECT INPUT REGISTER 16

R/W-0	R/W-0	R/W-0	R/W-0	R/W-0	R/W-0	R/W-0	R/W-0
QEIB2R7	QEIB2R6	QEIB2R5	QEIB2R4	QEIB2R3	QEIB2R2	QEIB2R1	QEIB2R0
bit 15							bit 8

R/W-0	R/W-0	R/W-0	R/W-0	R/W-0	R/W-0	R/W-0	R/W-0
QEIA2R7	QEIA2R6	QEIA2R5	QEIA2R4	QEIA2R3	QEIA2R2	QEIA2R1	QEIA2R0
bit 7							bit 0

### Legend:

R = Readable bit                      W = Writable bit                      U = Unimplemented bit, read as '0'  
 -n = Value at POR                      '1' = Bit is set                      '0' = Bit is cleared                      x = Bit is unknown

bit 15-8        **QEIB2R[7:0]:** Assign QEI2 Input B (QEIB2) to the Corresponding RPn Pin bits  
 See [Table 8-4](#).

bit 7-0        **QEIA2R[7:0]:** Assign QEI2 Input A (QEIA2) to the Corresponding RPn Pin bits  
 See [Table 8-4](#).

# dsPIC33CK256MP508 FAMILY

## REGISTER 8-31: RPINR17: PERIPHERAL PIN SELECT INPUT REGISTER 17

R/W-0	R/W-0	R/W-0	R/W-0	R/W-0	R/W-0	R/W-0	R/W-0
QEIHOM2R7	QEIHOM2R6	QEIHOM2R5	QEIHOM2R4	QEIHOM2R3	QEIHOM2R2	QEIHOM2R1	QEIHOM2R0
bit 15							bit 8

R/W-0	R/W-0	R/W-0	R/W-0	R/W-0	R/W-0	R/W-0	R/W-0
QEINDX2R7	QEINDX2R6	QEINDX2R5	QEINDX2R4	QEINDX2R3	QEINDX2R2	QEINDX2R1	QEINDX2R0
bit 7							bit 0

### Legend:

R = Readable bit                      W = Writable bit                      U = Unimplemented bit, read as '0'  
 -n = Value at POR                      '1' = Bit is set                      '0' = Bit is cleared                      x = Bit is unknown

bit 15-8                      **QEIHOM2R[7:0]**: Assign QEI Home 2 Input (QEIHOM2) to the Corresponding RPn Pin bits  
 See [Table 8-4](#).

bit 7-0                      **QEINDX2R[7:0]**: Assign QEI Index 2 Input (QEINDX2) to the Corresponding RPn Pin bits  
 See [Table 8-4](#).

## REGISTER 8-32: RPINR18: PERIPHERAL PIN SELECT INPUT REGISTER 18

R/W-0	R/W-0	R/W-0	R/W-0	R/W-0	R/W-0	R/W-0	R/W-0
U1DSRR7	U1DSRR6	U1DSRR5	U1DSRR4	U1DSRR3	U1DSRR2	U1DSRR1	U1DSRR0
bit 15							bit 8

R/W-0	R/W-0	R/W-0	R/W-0	R/W-0	R/W-0	R/W-0	R/W-0
U1RXR7	U1RXR6	U1RXR5	U1RXR4	U1RXR3	U1RXR2	U1RXR1	U1RXR0
bit 7							bit 0

### Legend:

R = Readable bit                      W = Writable bit                      U = Unimplemented bit, read as '0'  
 -n = Value at POR                      '1' = Bit is set                      '0' = Bit is cleared                      x = Bit is unknown

bit 15-8                      **U1DSRR[7:0]**: Assign UART1 Data-Set-Ready ( $\overline{U1DSR}$ ) to the Corresponding RPn Pin bits  
 See [Table 8-4](#).

bit 7-0                      **U1RXR[7:0]**: Assign UART1 Receive (U1RX) to the Corresponding RPn Pin bits  
 See [Table 8-4](#).

# dsPIC33CK256MP508 FAMILY

## REGISTER 8-33: RPINR19: PERIPHERAL PIN SELECT INPUT REGISTER 19

R/W-0	R/W-0	R/W-0	R/W-0	R/W-0	R/W-0	R/W-0	R/W-0
U2DSRR7	U2DSRR6	U2DSRR5	U2DSRR4	U2DSRR3	U2DSRR2	U2DSRR1	U2DSRR0
bit 15							bit 8

R/W-0	R/W-0	R/W-0	R/W-0	R/W-0	R/W-0	R/W-0	R/W-0
U2RXR7	U2RXR6	U2RXR5	U2RXR4	U2RXR3	U2RXR2	U2RXR1	U2RXR0
bit 7							bit 0

### Legend:

R = Readable bit                      W = Writable bit                      U = Unimplemented bit, read as '0'  
 -n = Value at POR                      '1' = Bit is set                      '0' = Bit is cleared                      x = Bit is unknown

bit 15-8            **U2DSRR[7:0]**: Assign UART2 Data-Set-Ready ( $\overline{U2DSR}$ ) to the Corresponding RPn Pin bits  
 See [Table 8-4](#).

bit 7-0            **U2RXR[7:0]**: Assign UART2 Receive (U2RX) to the Corresponding RPn Pin bits  
 See [Table 8-4](#).

## REGISTER 8-34: RPINR20: PERIPHERAL PIN SELECT INPUT REGISTER 20

R/W-0	R/W-0	R/W-0	R/W-0	R/W-0	R/W-0	R/W-0	R/W-0
SCK1R7	SCK1R6	SCK1R5	SCK1R4	SCK1R3	SCK1R2	SCK1R1	SCK1R0
bit 15							bit 8

R/W-0	R/W-0	R/W-0	R/W-0	R/W-0	R/W-0	R/W-0	R/W-0
SDI1R7	SDI1R6	SDI1R5	SDI1R4	SDI1R3	SDI1R2	SDI1R1	SDI1R0
bit 7							bit 0

### Legend:

R = Readable bit                      W = Writable bit                      U = Unimplemented bit, read as '0'  
 -n = Value at POR                      '1' = Bit is set                      '0' = Bit is cleared                      x = Bit is unknown

bit 15-8            **SCK1R[7:0]**: Assign SPI1 Clock Input (SCK1IN) to the Corresponding RPn Pin bits  
 See [Table 8-4](#).

bit 7-0            **SDI1R[7:0]**: Assign SPI1 Data Input (SDI1) to the Corresponding RPn Pin bits  
 See [Table 8-4](#).

# dsPIC33CK256MP508 FAMILY

## REGISTER 8-35: RPINR21: PERIPHERAL PIN SELECT INPUT REGISTER 21

R/W-0	R/W-0	R/W-0	R/W-0	R/W-0	R/W-0	R/W-0	R/W-0
REFOIR7	REFOIR6	REFOIR5	REFOIR4	REFOIR3	REFOIR2	REFOIR1	REFOIR0
bit 15							bit 8

R/W-0	R/W-0	R/W-0	R/W-0	R/W-0	R/W-0	R/W-0	R/W-0
SS1R7	SS1R6	SS1R5	SS1R4	SS1R3	SS1R2	SS1R1	SS1R0
bit 7							bit 0

### Legend:

R = Readable bit                      W = Writable bit                      U = Unimplemented bit, read as '0'  
 -n = Value at POR                      '1' = Bit is set                      '0' = Bit is cleared                      x = Bit is unknown

bit 15-8                      **REFOIR[7:0]:** Assign Reference Clock Input (REFOI) to the Corresponding RPn Pin bits  
 See [Table 8-4](#).

bit 7-0                      **SS1R[7:0]:** Assign SPI1 Client Select ( $\overline{SS1}$ ) to the Corresponding RPn Pin bits  
 See [Table 8-4](#).

## REGISTER 8-36: RPINR22: PERIPHERAL PIN SELECT INPUT REGISTER 22

R/W-0	R/W-0	R/W-0	R/W-0	R/W-0	R/W-0	R/W-0	R/W-0
SCK2R7	SCK2R6	SCK2R5	SCK2R4	SCK2R3	SCK2R2	SCK2R1	SCK2R0
bit 15							bit 8

R/W-0	R/W-0	R/W-0	R/W-0	R/W-0	R/W-0	R/W-0	R/W-0
SDI2R7	SDI2R6	SDI2R5	SDI2R4	SDI2R3	SDI2R2	SDI2R1	SDI2R0
bit 7							bit 0

### Legend:

R = Readable bit                      W = Writable bit                      U = Unimplemented bit, read as '0'  
 -n = Value at POR                      '1' = Bit is set                      '0' = Bit is cleared                      x = Bit is unknown

bit 15-8                      **SCK2R[7:0]:** Assign SPI2 Clock Input (SCK2IN) to the Corresponding RPn Pin bits  
 See [Table 8-4](#).

bit 7-0                      **SDI2R[7:0]:** Assign SPI2 Data Input (SDI2) to the Corresponding RPn Pin bits  
 See [Table 8-4](#).

# dsPIC33CK256MP508 FAMILY

## REGISTER 8-37: RPINR23: PERIPHERAL PIN SELECT INPUT REGISTER 23

U-0	U-0	U-0	U-0	U-0	U-0	U-0	U-0
—	—	—	—	—	—	—	—
bit 15							bit 8

R/W-0	R/W-0	R/W-0	R/W-0	R/W-0	R/W-0	R/W-0	R/W-0
SS2R7	SS2R6	SS2R5	SS2R4	SS2R3	SS2R2	SS2R1	SS2R0
bit 7							bit 0

**Legend:**

R = Readable bit                      W = Writable bit                      U = Unimplemented bit, read as '0'  
 -n = Value at POR                      '1' = Bit is set                      '0' = Bit is cleared                      x = Bit is unknown

bit 15-8                      **Unimplemented:** Read as '0'  
 bit 7-0                      **SS2R[7:0]:** Assign SPI2 Client Select ( $\overline{SS2}$ ) to the Corresponding RPN Pin bits  
 See [Table 8-4](#).

## REGISTER 8-38: RPINR26: PERIPHERAL PIN SELECT INPUT REGISTER 26

U-0	U-0	U-0	U-0	U-0	U-0	U-0	U-0
—	—	—	—	—	—	—	—
bit 15							bit 8

R/W-0	R/W-0	R/W-0	R/W-0	R/W-0	R/W-0	R/W-0	R/W-0
CAN1RXR7	CAN1RXR6	CAN1RXR5	CAN1RXR4	CAN1RXR3	CAN1RXR2	CAN1RXR1	CAN1RXR0
bit 7							bit 0

**Legend:**

R = Readable bit                      W = Writable bit                      U = Unimplemented bit, read as '0'  
 -n = Value at POR                      '1' = Bit is set                      '0' = Bit is cleared                      x = Bit is unknown

bit 15-8                      **Unimplemented:** Read as '0'  
 bit 7-0                      **CAN1RXR[7:0]:** Assign CAN1 Input (CAN1RX) to the Corresponding RPN Pin bits  
 See [Table 8-4](#).



# dsPIC33CK256MP508 FAMILY

## REGISTER 8-39: RPINR27: PERIPHERAL PIN SELECT INPUT REGISTER 27

R/W-0	R/W-0	R/W-0	R/W-0	R/W-0	R/W-0	R/W-0	R/W-0
U3DSRR7	U3DSRR6	U3DSRR5	U3DSRR4	U3DSRR3	U3DSRR2	U3DSRR1	U3DSRR0
bit 15							bit 8

R/W-0	R/W-0	R/W-0	R/W-0	R/W-0	R/W-0	R/W-0	R/W-0
U3RXR7	U3RXR6	U3RXR5	U3RXR4	U3RXR3	U3RXR2	U3RXR1	U3RXR0
bit 7							bit 0

### Legend:

R = Readable bit                      W = Writable bit                      U = Unimplemented bit, read as '0'  
 -n = Value at POR                      '1' = Bit is set                      '0' = Bit is cleared                      x = Bit is unknown

bit 15-8                      **U3DSRR[7:0]**: Assign UART3 Data-Set-Ready ( $\overline{U3DSR}$ ) to the Corresponding RPn Pin bits  
 See [Table 8-4](#).

bit 7-0                      **U3RXR[7:0]**: Assign UART3 Receive (U3RX) to the Corresponding RPn Pin bits  
 See [Table 8-4](#).

## REGISTER 8-40: RPINR29: PERIPHERAL PIN SELECT INPUT REGISTER 29

R/W-0	R/W-0	R/W-0	R/W-0	R/W-0	R/W-0	R/W-0	R/W-0
SCK3R7	SCK3R6	SCK3R5	SCK3R4	SCK3R3	SCK3R2	SCK3R1	SCK3R0
bit 15							bit 8

R/W-0	R/W-0	R/W-0	R/W-0	R/W-0	R/W-0	R/W-0	R/W-0
SDI3R7	SDI3R6	SDI3R5	SDI3R4	SDI3R3	SDI3R2	SDI3R1	SDI3R0
bit 7							bit 0

### Legend:

R = Readable bit                      W = Writable bit                      U = Unimplemented bit, read as '0'  
 -n = Value at POR                      '1' = Bit is set                      '0' = Bit is cleared                      x = Bit is unknown

bit 15-8                      **SCK3R[7:0]**: Assign SPI3 Clock Input (SCK3IN) to the Corresponding RPn Pin bits  
 See [Table 8-4](#).

bit 7-0                      **SDI3R[7:0]**: Assign SPI3 Data Input (SDI3) to the Corresponding RPn Pin bits  
 See [Table 8-4](#).

# dsPIC33CK256MP508 FAMILY

## REGISTER 8-41: RPINR30: PERIPHERAL PIN SELECT INPUT REGISTER 30

U-0	U-0	U-0	U-0	U-0	U-0	U-0	U-0
—	—	—	—	—	—	—	—
bit 15							bit 8

R/W-0	R/W-0	R/W-0	R/W-0	R/W-0	R/W-0	R/W-0	R/W-0
SS3R7	SS3R6	SS3R5	SS3R4	SS3R3	SS3R2	SS3R1	SS3R0
bit 7							bit 0

**Legend:**

R = Readable bit                      W = Writable bit                      U = Unimplemented bit, read as '0'  
 -n = Value at POR                      '1' = Bit is set                      '0' = Bit is cleared                      x = Bit is unknown

bit 15-8                      **Unimplemented:** Read as '0'  
 bit 7-0                      **SS3R[7:0]:** Assign SPI3 Client Select ( $\overline{SS2}$ ) to the Corresponding RPN Pin bits  
 See [Table 8-4](#).

## REGISTER 8-42: RPINR32: PERIPHERAL PIN SELECT INPUT REGISTER 32

R/W-0	R/W-0	R/W-0	R/W-0	R/W-0	R/W-0	R/W-0	R/W-0
TCKI9R7	TCKI9R6	TCKI9R5	TCKI9R4	TCKI9R3	TCKI9R2	TCKI9R1	TCKI9R0
bit 15							bit 8

U-0	U-0	U-0	U-0	U-0	U-0	U-0	U-0
—	—	—	—	—	—	—	—
bit 7							bit 0

**Legend:**

R = Readable bit                      W = Writable bit                      U = Unimplemented bit, read as '0'  
 -n = Value at POR                      '1' = Bit is set                      '0' = Bit is cleared                      x = Bit is unknown

bit 15-8                      **TCKI9R[7:0]:** Assign MCCP Timer9 Input (TCKI9) to the Corresponding RPN Pin bits  
 See [Table 8-4](#).  
 bit 7-0                      **Unimplemented:** Read as '0'

# dsPIC33CK256MP508 FAMILY

## REGISTER 8-43: RPINR33: PERIPHERAL PIN SELECT INPUT REGISTER 33

U-0	U-0	U-0	U-0	U-0	U-0	U-0	U-0
—	—	—	—	—	—	—	—
bit 15							bit 8

R/W-0	R/W-0	R/W-0	R/W-0	R/W-0	R/W-0	R/W-0	R/W-0
ICM9R7	ICM9R6	ICM9R5	ICM9R4	ICM9R3	ICM9R2	ICM9R1	ICM9R0
bit 7							bit 0

### Legend:

R = Readable bit                      W = Writable bit                      U = Unimplemented bit, read as '0'  
 -n = Value at POR                      '1' = Bit is set                      '0' = Bit is cleared                      x = Bit is unknown

bit 15-8                      **Unimplemented:** Read as '0'  
 bit 7-0                      **ICM9R[7:0]:** Assign MCCP Capture 9 Input (ICM9) to the Corresponding RPn Pin bits  
 See [Table 8-4](#).

## REGISTER 8-44: RPINR37: PERIPHERAL PIN SELECT INPUT REGISTER 37

R/W-0	R/W-0	R/W-0	R/W-0	R/W-0	R/W-0	R/W-0	R/W-0
PCI17R7	PCI17R6	PCI17R5	PCI17R4	PCI17R3	PCI17R2	PCI17R1	PCI17R0
bit 15							bit 8

R/W-0	R/W-0	R/W-0	R/W-0	R/W-0	R/W-0	R/W-0	R/W-0
OCFCR7	OCFCR6	OCFCR5	OCFCR4	OCFCR3	OCFCR2	OCFCR1	OCFCR0
bit 7							bit 0

### Legend:

R = Readable bit                      W = Writable bit                      U = Unimplemented bit, read as '0'  
 -n = Value at POR                      '1' = Bit is set                      '0' = Bit is cleared                      x = Bit is unknown

bit 15-8                      **PCI17R[7:0]:** Assign PWM Input 17 (PCI17) to the Corresponding RPn Pin bits  
 See [Table 8-4](#).  
 bit 7-0                      **OCFCR[7:0]:** Assign xCCP Fault C (OCFC) to the Corresponding RPn Pin bits  
 See [Table 8-4](#).

# dsPIC33CK256MP508 FAMILY

## REGISTER 8-45: RPINR38: PERIPHERAL PIN SELECT INPUT REGISTER 38

U-0	U-0	U-0	U-0	U-0	U-0	U-0	U-0
—	—	—	—	—	—	—	—
bit 15							bit 8

R/W-0	R/W-0	R/W-0	R/W-0	R/W-0	R/W-0	R/W-0	R/W-0
PCI18R7	PCI18R6	PCI18R5	PCI18R4	PCI18R3	PCI18R2	PCI18R1	PCI18R0
bit 7							bit 0

**Legend:**

R = Readable bit                      W = Writable bit                      U = Unimplemented bit, read as '0'  
 -n = Value at POR                      '1' = Bit is set                      '0' = Bit is cleared                      x = Bit is unknown

bit 15-8                      **Unimplemented:** Read as '0'  
 bit 7-0                      **PCI17R[7:0]:** Assign PWM Input 17 (PCI17) to the Corresponding RPN Pin bits  
 See [Table 8-4](#).

## REGISTER 8-46: RPINR42: PERIPHERAL PIN SELECT INPUT REGISTER 42

R/W-0	R/W-0	R/W-0	R/W-0	R/W-0	R/W-0	R/W-0	R/W-0
PCI13R7	PCI13R6	PCI13R5	PCI13R4	PCI13R3	PCI13R2	PCI13R1	PCI13R0
bit 15							bit 8

R/W-0	R/W-0	R/W-0	R/W-0	R/W-0	R/W-0	R/W-0	R/W-0
PCI12R7	PCI12R6	PCI12R5	PCI12R4	PCI12R3	PCI12R2	PCI12R1	PCI12R0
bit 7							bit 0

**Legend:**

R = Readable bit                      W = Writable bit                      U = Unimplemented bit, read as '0'  
 -n = Value at POR                      '1' = Bit is set                      '0' = Bit is cleared                      x = Bit is unknown

bit 15-8                      **PCI13R[7:0]:** Assign PWM Input 13 (PCI13) to the Corresponding RPN Pin bits  
 See [Table 8-4](#).  
 bit 7-0                      **PCI12R[7:0]:** Assign PWM Input 12 (PCI12) to the Corresponding RPN Pin bits  
 See [Table 8-4](#).

# dsPIC33CK256MP508 FAMILY

## REGISTER 8-47: RPINR43: PERIPHERAL PIN SELECT INPUT REGISTER 43

R/W-0	R/W-0	R/W-0	R/W-0	R/W-0	R/W-0	R/W-0	R/W-0
PCI15R7	PCI15R6	PCI15R5	PCI15R4	PCI15R3	PCI15R2	PCI15R1	PCI15R0
bit 15							bit 8

R/W-0	R/W-0	R/W-0	R/W-0	R/W-0	R/W-0	R/W-0	R/W-0
PCI14R7	PCI14R6	PCI14R5	PCI14R4	PCI14R3	PCI14R2	PCI14R1	PCI14R0
bit 7							bit 0

### Legend:

R = Readable bit                      W = Writable bit                      U = Unimplemented bit, read as '0'  
 -n = Value at POR                      '1' = Bit is set                      '0' = Bit is cleared                      x = Bit is unknown

bit 15-8                      **PCI15R[7:0]**: Assign PWM Input 15 (PCI15) to the Corresponding RPn Pin bits  
 See [Table 8-4](#).

bit 7-0                      **PCI14R[7:0]**: Assign PWM Input 14 (PCI14) to the Corresponding RPn Pin bits  
 See [Table 8-4](#).

## REGISTER 8-48: RPINR44: PERIPHERAL PIN SELECT INPUT REGISTER 44

R/W-0	R/W-0	R/W-0	R/W-0	R/W-0	R/W-0	R/W-0	R/W-0
SENT1R7	SENT1R6	SENT1R5	SENT1R4	SENT1R3	SENT1R2	SENT1R1	SENT1R0
bit 15							bit 8

R/W-0	R/W-0	R/W-0	R/W-0	R/W-0	R/W-0	R/W-0	R/W-0
PCI16R7	PCI16R6	PCI16R5	PCI16R4	PCI16R3	PCI16R2	PCI16R1	PCI16R0
bit 7							bit 0

### Legend:

R = Readable bit                      W = Writable bit                      U = Unimplemented bit, read as '0'  
 -n = Value at POR                      '1' = Bit is set                      '0' = Bit is cleared                      x = Bit is unknown

bit 15-8                      **SENT1R[7:0]**: Assign SENT1 Input (SENT1) to the Corresponding RPn Pin bits  
 See [Table 8-4](#).

bit 7-0                      **PCI16[7:0]**: Assign PWM Input 16 (PCI16) to the Corresponding RPn Pin bits  
 See [Table 8-4](#).

# dsPIC33CK256MP508 FAMILY

## REGISTER 8-49: RPINR45: PERIPHERAL PIN SELECT INPUT REGISTER 45

R/W-0	R/W-0	R/W-0	R/W-0	R/W-0	R/W-0	R/W-0	R/W-0
CLCINAR7	CLCINAR6	CLCINAR5	CLCINAR4	CLCINAR3	CLCINAR2	CLCINAR1	CLCINAR0
bit 15							bit 8

R/W-0	R/W-0	R/W-0	R/W-0	R/W-0	R/W-0	R/W-0	R/W-0
SENT2R7	SENT2R6	SENT2R5	SENT2R4	SENT2R3	SENT2R2	SENT2R1	SENT2R0
bit 7							bit 0

### Legend:

R = Readable bit                      W = Writable bit                      U = Unimplemented bit, read as '0'  
 -n = Value at POR                      '1' = Bit is set                      '0' = Bit is cleared                      x = Bit is unknown

bit 15-8                      **CLCINAR[7:0]**: Assign CLC Input A (CLCINA) to the Corresponding RPn Pin bits  
 See [Table 8-4](#).

bit 7-0                      **SENT2R[7:0]**: Assign SENT2 Input (SENT2) to the Corresponding RPn Pin bits  
 See [Table 8-4](#).

## REGISTER 8-50: RPINR46: PERIPHERAL PIN SELECT INPUT REGISTER 46

R/W-0	R/W-0	R/W-0	R/W-0	R/W-0	R/W-0	R/W-0	R/W-0
CLCINCR7	CLCINCR6	CLCINCR5	CLCINCR4	CLCINCR3	CLCINCR2	CLCINCR1	CLCINCR0
bit 15							bit 8

R/W-0	R/W-0	R/W-0	R/W-0	R/W-0	R/W-0	R/W-0	R/W-0
CLCINBR7	CLCINBR6	CLCINBR5	CLCINBR4	CLCINBR3	CLCINBR2	CLCINBR1	CLCINBR0
bit 7							bit 0

### Legend:

R = Readable bit                      W = Writable bit                      U = Unimplemented bit, read as '0'  
 -n = Value at POR                      '1' = Bit is set                      '0' = Bit is cleared                      x = Bit is unknown

bit 15-8                      **CLCINCR[7:0]**: Assign CLC Input C (CLCINC) to the Corresponding RPn Pin bits  
 See [Table 8-4](#).

bit 7-0                      **CLCINBR[7:0]**: Assign CLC Input B (CLCINB) to the Corresponding RPn Pin bits  
 See [Table 8-4](#).

# dsPIC33CK256MP508 FAMILY

## REGISTER 8-51: RPINR47: PERIPHERAL PIN SELECT INPUT REGISTER 47

R/W-0	R/W-0	R/W-0	R/W-0	R/W-0	R/W-0	R/W-0	R/W-0
ADCTRGR7	ADCTRGR6	ADCTRGR5	ADCTRGR4	ADCTRGR3	ADCTRGR2	ADCTRGR1	ADCTRGR0
bit 15							bit 8

R/W-0	R/W-0	R/W-0	R/W-0	R/W-0	R/W-0	R/W-0	R/W-0
CLCINDR7	CLCINDR6	CLCINDR5	CLCINDR4	CLCINDR3	CLCINDR2	CLCINDR1	CLCINDR0
bit 7							bit 0

### Legend:

R = Readable bit                      W = Writable bit                      U = Unimplemented bit, read as '0'  
 -n = Value at POR                      '1' = Bit is set                      '0' = Bit is cleared                      x = Bit is unknown

bit 15-8                      **ADCTRGR[7:0]:** Assign ADC Trigger Input (ADCTRG) to the Corresponding RPn Pin bits  
 See [Table 8-4](#).

bit 7-0                      **CLCINDR[7:0]:** Assign CLC Input D (CLCIND) to the Corresponding RPn Pin bits  
 See [Table 8-4](#).

## REGISTER 8-52: RPINR48: PERIPHERAL PIN SELECT INPUT REGISTER 48

R/W-0	R/W-0	R/W-0	R/W-0	R/W-0	R/W-0	R/W-0	R/W-0
U1CTSR7	U1CTSR6	U1CTSR5	U1CTSR4	U1CTSR3	U1CTSR2	U1CTSR1	U1CTSR0
bit 15							bit 8

R/W-0	R/W-0	R/W-0	R/W-0	R/W-0	R/W-0	R/W-0	R/W-0
OCFDR7	OCFDR6	OCFDR5	OCFDR4	OCFDR3	OCFDR2	OCFDR1	OCFDR0
bit 7							bit 0

### Legend:

R = Readable bit                      W = Writable bit                      U = Unimplemented bit, read as '0'  
 -n = Value at POR                      '1' = Bit is set                      '0' = Bit is cleared                      x = Bit is unknown

bit 15-8                      **U1CTSR[7:0]:** Assign UART1 Clear-to-Send ( $\overline{U1CTS}$ ) to the Corresponding RPn Pin bits  
 See [Table 8-4](#).

bit 7-0                      **OCFDR[7:0]:** Assign xCCP Fault D (OCFD) to the Corresponding RPn Pin bits  
 See [Table 8-4](#).

# dsPIC33CK256MP508 FAMILY

## REGISTER 8-53: RPINR49: PERIPHERAL PIN SELECT INPUT REGISTER 49

R/W-0	R/W-0	R/W-0	R/W-0	R/W-0	R/W-0	R/W-0	R/W-0
U3CTSR7	U3CTSR6	U3CTSR5	U3CTSR4	U3CTSR3	U3CTSR2	U3CTSR1	U3CTSR0
bit 15							bit 8

R/W-0	R/W-0	R/W-0	R/W-0	R/W-0	R/W-0	R/W-0	R/W-0
U2CTSR7	U2CTSR6	U2CTSR5	U2CTSR4	U2CTSR3	U2CTSR2	U2CTSR1	U2CTSR0
bit 7							bit 0

### Legend:

R = Readable bit	W = Writable bit	U = Unimplemented bit, read as '0'
-n = Value at POR	'1' = Bit is set	'0' = Bit is cleared      x = Bit is unknown

bit 15-8      **U3CTSR[7:0]:** Assign UART3 Clear-to-Send ( $\overline{U3CTS}$ ) to the Corresponding RPn Pin bits  
See [Table 8-4](#).

bit 7-0      **U2CTSR[7:0]:** Assign UART2 Clear-to-Send ( $\overline{U2CTS}$ ) to the Corresponding RPn Pin bits  
See [Table 8-4](#).



# dsPIC33CK256MP508 FAMILY

## REGISTER 8-54: RPOR0: PERIPHERAL PIN SELECT OUTPUT REGISTER 0

U-0	U-0	R/W-0	R/W-0	R/W-0	R/W-0	R/W-0	R/W-0
—	—	RP33R5	RP33R4	RP33R3	RP33R2	RP33R1	RP33R0
bit 15							bit 8

U-0	U-0	R/W-0	R/W-0	R/W-0	R/W-0	R/W-0	R/W-0
—	—	RP32R5	RP32R4	RP32R3	RP32R2	RP32R1	RP32R0
bit 7							bit 0

### Legend:

R = Readable bit                      W = Writable bit                      U = Unimplemented bit, read as '0'  
 -n = Value at POR                      '1' = Bit is set                      '0' = Bit is cleared                      x = Bit is unknown

- bit 15-14      **Unimplemented:** Read as '0'
- bit 13-8      **RP33R[5:0]:** Peripheral Output Function is Assigned to RP33 Output Pin bits  
 (see [Table 8-7](#) for peripheral function numbers)
- bit 7-6      **Unimplemented:** Read as '0'
- bit 5-0      **RP32R[5:0]:** Peripheral Output Function is Assigned to RP32 Output Pin bits  
 (see [Table 8-7](#) for peripheral function numbers)

## REGISTER 8-55: RPOR1: PERIPHERAL PIN SELECT OUTPUT REGISTER 1

U-0	U-0	R/W-0	R/W-0	R/W-0	R/W-0	R/W-0	R/W-0
—	—	RP35R5	RP35R4	RP35R3	RP35R2	RP35R1	RP35R0
bit 15							bit 8

U-0	U-0	R/W-0	R/W-0	R/W-0	R/W-0	R/W-0	R/W-0
—	—	RP34R5	RP34R4	RP34R3	RP34R2	RP34R1	RP34R0
bit 7							bit 0

### Legend:

R = Readable bit                      W = Writable bit                      U = Unimplemented bit, read as '0'  
 -n = Value at POR                      '1' = Bit is set                      '0' = Bit is cleared                      x = Bit is unknown

- bit 15-14      **Unimplemented:** Read as '0'
- bit 13-8      **RP35R[5:0]:** Peripheral Output Function is Assigned to RP35 Output Pin bits  
 (see [Table 8-7](#) for peripheral function numbers)
- bit 7-6      **Unimplemented:** Read as '0'
- bit 5-0      **RP34R[5:0]:** Peripheral Output Function is Assigned to RP34 Output Pin bits  
 (see [Table 8-7](#) for peripheral function numbers)

# dsPIC33CK256MP508 FAMILY

## REGISTER 8-56: RPOR2: PERIPHERAL PIN SELECT OUTPUT REGISTER 2

U-0	U-0	R/W-0	R/W-0	R/W-0	R/W-0	R/W-0	R/W-0
—	—	RP37R5	RP37R4	RP37R3	RP37R2	RP37R1	RP37R0
bit 15							bit 8

U-0	U-0	R/W-0	R/W-0	R/W-0	R/W-0	R/W-0	R/W-0
—	—	RP36R5	RP36R4	RP36R3	RP36R2	RP36R1	RP36R0
bit 7							bit 0

### Legend:

R = Readable bit                      W = Writable bit                      U = Unimplemented bit, read as '0'  
 -n = Value at POR                      '1' = Bit is set                      '0' = Bit is cleared                      x = Bit is unknown

- bit 15-14      **Unimplemented:** Read as '0'
- bit 13-8      **RP37R[5:0]:** Peripheral Output Function is Assigned to RP37 Output Pin bits  
 (see [Table 8-7](#) for peripheral function numbers)
- bit 7-6      **Unimplemented:** Read as '0'
- bit 5-0      **RP36R[5:0]:** Peripheral Output Function is Assigned to RP36 Output Pin bits  
 (see [Table 8-7](#) for peripheral function numbers)

## REGISTER 8-57: RPOR3: PERIPHERAL PIN SELECT OUTPUT REGISTER 3

U-0	U-0	R/W-0	R/W-0	R/W-0	R/W-0	R/W-0	R/W-0
—	—	RP39R5	RP39R4	RP39R3	RP39R2	RP39R1	RP39R0
bit 15							bit 8

U-0	U-0	R/W-0	R/W-0	R/W-0	R/W-0	R/W-0	R/W-0
—	—	RP38R5	RP38R5	RP38R5	RP38R5	RP38R5	RP38R5
bit 7							bit 0

### Legend:

R = Readable bit                      W = Writable bit                      U = Unimplemented bit, read as '0'  
 -n = Value at POR                      '1' = Bit is set                      '0' = Bit is cleared                      x = Bit is unknown

- bit 15-14      **Unimplemented:** Read as '0'
- bit 13-8      **RP39R[5:0]:** Peripheral Output Function is Assigned to RP39 Output Pin bits  
 (see [Table 8-7](#) for peripheral function numbers)
- bit 7-6      **Unimplemented:** Read as '0'
- bit 5-0      **RP38R[5:0]:** Peripheral Output Function is Assigned to RP38 Output Pin bits  
 (see [Table 8-7](#) for peripheral function numbers)

# dsPIC33CK256MP508 FAMILY

## REGISTER 8-58: RPOR4: PERIPHERAL PIN SELECT OUTPUT REGISTER 4

U-0	U-0	R/W-0	R/W-0	R/W-0	R/W-0	R/W-0	R/W-0
—	—	RP41R5	RP41R4	RP41R3	RP41R2	RP41R1	RP41R0
bit 15							bit 8

U-0	U-0	R/W-0	R/W-0	R/W-0	R/W-0	R/W-0	R/W-0
—	—	RP40R5	RP40R4	RP40R3	RP40R2	RP40R1	RP40R0
bit 7							bit 0

### Legend:

R = Readable bit                      W = Writable bit                      U = Unimplemented bit, read as '0'  
 -n = Value at POR                      '1' = Bit is set                      '0' = Bit is cleared                      x = Bit is unknown

- bit 15-14      **Unimplemented:** Read as '0'
- bit 13-8      **RP41R[5:0]:** Peripheral Output Function is Assigned to RP41 Output Pin bits  
 (see [Table 8-7](#) for peripheral function numbers)
- bit 7-6      **Unimplemented:** Read as '0'
- bit 5-0      **RP40R[5:0]:** Peripheral Output Function is Assigned to RP40 Output Pin bits  
 (see [Table 8-7](#) for peripheral function numbers)

## REGISTER 8-59: RPOR5: PERIPHERAL PIN SELECT OUTPUT REGISTER 5

U-0	U-0	R/W-0	R/W-0	R/W-0	R/W-0	R/W-0	R/W-0
—	—	RP43R5	RP43R4	RP43R3	RP43R2	RP43R1	RP43R0
bit 15							bit 8

U-0	U-0	R/W-0	R/W-0	R/W-0	R/W-0	R/W-0	R/W-0
—	—	RP42R5	RP42R4	RP42R3	RP42R2	RP42R1	RP42R0
bit 7							bit 0

### Legend:

R = Readable bit                      W = Writable bit                      U = Unimplemented bit, read as '0'  
 -n = Value at POR                      '1' = Bit is set                      '0' = Bit is cleared                      x = Bit is unknown

- bit 15-14      **Unimplemented:** Read as '0'
- bit 13-8      **RP43R[5:0]:** Peripheral Output Function is Assigned to RP43 Output Pin bits  
 (see [Table 8-7](#) for peripheral function numbers)
- bit 7-6      **Unimplemented:** Read as '0'
- bit 5-0      **RP42R[5:0]:** Peripheral Output Function is Assigned to RP42 Output Pin bits  
 (see [Table 8-7](#) for peripheral function numbers)

# dsPIC33CK256MP508 FAMILY

## REGISTER 8-60: RPOR6: PERIPHERAL PIN SELECT OUTPUT REGISTER 6

U-0	U-0	R/W-0	R/W-0	R/W-0	R/W-0	R/W-0	R/W-0
—	—	RP45R5	RP45R4	RP45R3	RP45R2	RP45R1	RP45R0
bit 15							bit 8

U-0	U-0	R/W-0	R/W-0	R/W-0	R/W-0	R/W-0	R/W-0
—	—	RP44R5	RP44R4	RP44R3	RP44R2	RP44R1	RP44R0
bit 7							bit 0

### Legend:

R = Readable bit                      W = Writable bit                      U = Unimplemented bit, read as '0'  
 -n = Value at POR                      '1' = Bit is set                      '0' = Bit is cleared                      x = Bit is unknown

- bit 15-14      **Unimplemented:** Read as '0'
- bit 13-8      **RP45R[5:0]:** Peripheral Output Function is Assigned to RP45 Output Pin bits  
 (see [Table 8-7](#) for peripheral function numbers)
- bit 7-6        **Unimplemented:** Read as '0'
- bit 5-0        **RP44R[5:0]:** Peripheral Output Function is Assigned to RP44 Output Pin bits  
 (see [Table 8-7](#) for peripheral function numbers)

## REGISTER 8-61: RPOR7: PERIPHERAL PIN SELECT OUTPUT REGISTER 7

U-0	U-0	R/W-0	R/W-0	R/W-0	R/W-0	R/W-0	R/W-0
—	—	RP47R5	RP47R4	RP47R3	RP47R2	RP47R1	RP47R0
bit 15							bit 8

U-0	U-0	R/W-0	R/W-0	R/W-0	R/W-0	R/W-0	R/W-0
—	—	RP46R5	RP46R4	RP46R3	RP46R2	RP46R1	RP46R0
bit 7							bit 0

### Legend:

R = Readable bit                      W = Writable bit                      U = Unimplemented bit, read as '0'  
 -n = Value at POR                      '1' = Bit is set                      '0' = Bit is cleared                      x = Bit is unknown

- bit 15-14      **Unimplemented:** Read as '0'
- bit 13-8      **RP47R[5:0]:** Peripheral Output Function is Assigned to RP47 Output Pin bits  
 (see [Table 8-7](#) for peripheral function numbers)
- bit 7-6        **Unimplemented:** Read as '0'
- bit 5-0        **RP46R[5:0]:** Peripheral Output Function is Assigned to RP46 Output Pin bits  
 (see [Table 8-7](#) for peripheral function numbers)

# dsPIC33CK256MP508 FAMILY

## REGISTER 8-62: RPOR8: PERIPHERAL PIN SELECT OUTPUT REGISTER 8

U-0	U-0	R/W-0	R/W-0	R/W-0	R/W-0	R/W-0	R/W-0
—	—	RP49R5	RP49R4	RP49R3	RP49R2	RP49R1	RP49R0
bit 15							bit 8

U-0	U-0	R/W-0	R/W-0	R/W-0	R/W-0	R/W-0	R/W-0
—	—	RP48R5	RP48R4	RP48R3	RP48R2	RP48R1	RP48R0
bit 7							bit 0

### Legend:

R = Readable bit                      W = Writable bit                      U = Unimplemented bit, read as '0'  
 -n = Value at POR                      '1' = Bit is set                      '0' = Bit is cleared                      x = Bit is unknown

- bit 15-14      **Unimplemented:** Read as '0'
- bit 13-8      **RP49R[5:0]:** Peripheral Output Function is Assigned to RP49 Output Pin bits  
 (see [Table 8-7](#) for peripheral function numbers)
- bit 7-6      **Unimplemented:** Read as '0'
- bit 5-0      **RP48R[5:0]:** Peripheral Output Function is Assigned to RP48 Output Pin bits  
 (see [Table 8-7](#) for peripheral function numbers)

## REGISTER 8-63: RPOR9: PERIPHERAL PIN SELECT OUTPUT REGISTER 9

U-0	U-0	R/W-0	R/W-0	R/W-0	R/W-0	R/W-0	R/W-0
—	—	RP51R5	RP51R4	RP51R3	RP51R2	RP51R1	RP51R0
bit 15							bit 8

U-0	U-0	R/W-0	R/W-0	R/W-0	R/W-0	R/W-0	R/W-0
—	—	RP50R5	RP50R4	RP50R3	RP50R2	RP50R1	RP50R0
bit 7							bit 0

### Legend:

R = Readable bit                      W = Writable bit                      U = Unimplemented bit, read as '0'  
 -n = Value at POR                      '1' = Bit is set                      '0' = Bit is cleared                      x = Bit is unknown

- bit 15-14      **Unimplemented:** Read as '0'
- bit 13-8      **RP51R[5:0]:** Peripheral Output Function is Assigned to RP51 Output Pin bits  
 (see [Table 8-7](#) for peripheral function numbers)
- bit 7-6      **Unimplemented:** Read as '0'
- bit 5-0      **RP50R[5:0]:** Peripheral Output Function is Assigned to RP50 Output Pin bits  
 (see [Table 8-7](#) for peripheral function numbers)

# dsPIC33CK256MP508 FAMILY

## REGISTER 8-64: RPOR10: PERIPHERAL PIN SELECT OUTPUT REGISTER 10

U-0	U-0	R/W-0	R/W-0	R/W-0	R/W-0	R/W-0	R/W-0
—	—	RP53R5	RP53R4	RP53R3	RP53R2	RP53R1	RP53R0
bit 15							bit 8

U-0	U-0	R/W-0	R/W-0	R/W-0	R/W-0	R/W-0	R/W-0
—	—	RP52R5	RP52R4	RP52R3	RP52R2	RP52R1	RP52R0
bit 7							bit 0

### Legend:

R = Readable bit                      W = Writable bit                      U = Unimplemented bit, read as '0'  
 -n = Value at POR                      '1' = Bit is set                      '0' = Bit is cleared                      x = Bit is unknown

- bit 15-14      **Unimplemented:** Read as '0'
- bit 13-8      **RP53[5:0]:** Peripheral Output Function is Assigned to RP53 Output Pin bits  
 (see [Table 8-7](#) for peripheral function numbers)
- bit 7-6      **Unimplemented:** Read as '0'
- bit 5-0      **RP52R[5:0]:** Peripheral Output Function is Assigned to RP52 Output Pin bits  
 (see [Table 8-7](#) for peripheral function numbers)

## REGISTER 8-65: RPOR11: PERIPHERAL PIN SELECT OUTPUT REGISTER 11

U-0	U-0	R/W-0	R/W-0	R/W-0	R/W-0	R/W-0	R/W-0
—	—	RP55R5	RP55R4	RP55R3	RP55R2	RP55R1	RP55R0
bit 15							bit 8

U-0	U-0	R/W-0	R/W-0	R/W-0	R/W-0	R/W-0	R/W-0
—	—	RP54R5	RP54R4	RP54R3	RP54R2	RP54R1	RP54R0
bit 7							bit 0

### Legend:

R = Readable bit                      W = Writable bit                      U = Unimplemented bit, read as '0'  
 -n = Value at POR                      '1' = Bit is set                      '0' = Bit is cleared                      x = Bit is unknown

- bit 15-14      **Unimplemented:** Read as '0'
- bit 13-8      **RP55R[5:0]:** Peripheral Output Function is Assigned to RP55 Output Pin bits  
 (see [Table 8-7](#) for peripheral function numbers)
- bit 7-6      **Unimplemented:** Read as '0'
- bit 5-0      **RP54R[5:0]:** Peripheral Output Function is Assigned to RP54 Output Pin bits  
 (see [Table 8-7](#) for peripheral function numbers)

# dsPIC33CK256MP508 FAMILY

## REGISTER 8-66: RPOR12: PERIPHERAL PIN SELECT OUTPUT REGISTER 12

U-0	U-0	R/W-0	R/W-0	R/W-0	R/W-0	R/W-0	R/W-0
—	—	RP57R5	RP57R4	RP57R3	RP57R2	RP57R1	RP57R0
bit 15							bit 8

U-0	U-0	R/W-0	R/W-0	R/W-0	R/W-0	R/W-0	R/W-0
—	—	RP56R5	RP56R4	RP56R3	RP56R2	RP56R1	RP56R0
bit 7							bit 0

### Legend:

R = Readable bit                      W = Writable bit                      U = Unimplemented bit, read as '0'  
 -n = Value at POR                      '1' = Bit is set                      '0' = Bit is cleared                      x = Bit is unknown

- bit 15-14      **Unimplemented:** Read as '0'
- bit 13-8      **RP57R[5:0]:** Peripheral Output Function is Assigned to RP57 Output Pin bits  
 (see [Table 8-7](#) for peripheral function numbers)
- bit 7-6      **Unimplemented:** Read as '0'
- bit 5-0      **RP56R[5:0]:** Peripheral Output Function is Assigned to RP56 Output Pin bits  
 (see [Table 8-7](#) for peripheral function numbers)

## REGISTER 8-67: RPOR13: PERIPHERAL PIN SELECT OUTPUT REGISTER 13

U-0	U-0	R/W-0	R/W-0	R/W-0	R/W-0	R/W-0	R/W-0
—	—	RP59R5	RP59R4	RP59R3	RP59R2	RP59R1	RP59R0
bit 15							bit 8

U-0	U-0	R/W-0	R/W-0	R/W-0	R/W-0	R/W-0	R/W-0
—	—	RP58R5	RP58R4	RP58R3	RP58R2	RP58R1	RP58R0
bit 7							bit 0

### Legend:

R = Readable bit                      W = Writable bit                      U = Unimplemented bit, read as '0'  
 -n = Value at POR                      '1' = Bit is set                      '0' = Bit is cleared                      x = Bit is unknown

- bit 15-14      **Unimplemented:** Read as '0'
- bit 13-8      **RP59R[5:0]:** Peripheral Output Function is Assigned to RP59 Output Pin bits  
 (see [Table 8-7](#) for peripheral function numbers)
- bit 7-6      **Unimplemented:** Read as '0'
- bit 5-0      **RP58R[5:0]:** Peripheral Output Function is Assigned to RP58 Output Pin bits  
 (see [Table 8-7](#) for peripheral function numbers)

# dsPIC33CK256MP508 FAMILY

## REGISTER 8-68: RPOR14: PERIPHERAL PIN SELECT OUTPUT REGISTER 14

U-0	U-0	R/W-0	R/W-0	R/W-0	R/W-0	R/W-0	R/W-0
—	—	RP61R5	RP61R4	RP61R3	RP61R2	RP61R1	RP61R0
bit 15							bit 8

U-0	U-0	R/W-0	R/W-0	R/W-0	R/W-0	R/W-0	R/W-0
—	—	RP60R5	RP60R4	RP60R3	RP60R2	RP60R1	RP60R0
bit 7							bit 0

### Legend:

R = Readable bit                      W = Writable bit                      U = Unimplemented bit, read as '0'  
 -n = Value at POR                      '1' = Bit is set                      '0' = Bit is cleared                      x = Bit is unknown

- bit 15-14      **Unimplemented:** Read as '0'
- bit 13-8      **RP61R[5:0]:** Peripheral Output Function is Assigned to RP61 Output Pin bits  
 (see [Table 8-7](#) for peripheral function numbers)
- bit 7-6        **Unimplemented:** Read as '0'
- bit 5-0        **RP60R[5:0]:** Peripheral Output Function is Assigned to RP60 Output Pin bits  
 (see [Table 8-7](#) for peripheral function numbers)

## REGISTER 8-69: RPOR15: PERIPHERAL PIN SELECT OUTPUT REGISTER 15

U-0	U-0	R/W-0	R/W-0	R/W-0	R/W-0	R/W-0	R/W-0
—	—	RP63R5	RP63R4	RP63R3	RP63R2	RP63R1	RP63R0
bit 15							bit 8

U-0	U-0	R/W-0	R/W-0	R/W-0	R/W-0	R/W-0	R/W-0
—	—	RP62R5	RP62R4	RP62R3	RP62R2	RP62R1	RP62R0
bit 7							bit 0

### Legend:

R = Readable bit                      W = Writable bit                      U = Unimplemented bit, read as '0'  
 -n = Value at POR                      '1' = Bit is set                      '0' = Bit is cleared                      x = Bit is unknown

- bit 15-14      **Unimplemented:** Read as '0'
- bit 13-8      **RP63R[5:0]:** Peripheral Output Function is Assigned to RP63 Output Pin bits  
 (see [Table 8-7](#) for peripheral function numbers)
- bit 7-6        **Unimplemented:** Read as '0'
- bit 5-0        **RP62R[5:0]:** Peripheral Output Function is Assigned to RP62 Output Pin bits  
 (see [Table 8-7](#) for peripheral function numbers)



# dsPIC33CK256MP508 FAMILY

## REGISTER 8-70: RPOR16: PERIPHERAL PIN SELECT OUTPUT REGISTER 16

U-0	U-0	R/W-0	R/W-0	R/W-0	R/W-0	R/W-0	R/W-0
—	—	RP65R5	RP65R4	RP65R3	RP65R2	RP65R1	RP65R0
bit 15							bit 8

U-0	U-0	R/W-0	R/W-0	R/W-0	R/W-0	R/W-0	R/W-0
—	—	RP64R5	RP64R4	RP64R3	RP64R2	RP64R1	RP64R0
bit 7							bit 0

### Legend:

R = Readable bit                      W = Writable bit                      U = Unimplemented bit, read as '0'  
 -n = Value at POR                      '1' = Bit is set                      '0' = Bit is cleared                      x = Bit is unknown

- bit 15-14      **Unimplemented:** Read as '0'
- bit 13-8      **RP65R[5:0]:** Peripheral Output Function is Assigned to RP65 Output Pin bits  
 (see [Table 8-7](#) for peripheral function numbers)
- bit 7-6      **Unimplemented:** Read as '0'
- bit 5-0      **RP64R[5:0]:** Peripheral Output Function is Assigned to RP64 Output Pin bits  
 (see [Table 8-7](#) for peripheral function numbers)

## REGISTER 8-71: RPOR17: PERIPHERAL PIN SELECT OUTPUT REGISTER 17

U-0	U-0	R/W-0	R/W-0	R/W-0	R/W-0	R/W-0	R/W-0
—	—	RP67R5	RP67R4	RP67R3	RP67R2	RP67R1	RP67R0
bit 15							bit 8

U-0	U-0	R/W-0	R/W-0	R/W-0	R/W-0	R/W-0	R/W-0
—	—	RP66R5	RP66R4	RP66R3	RP66R2	RP66R1	RP66R0
bit 7							bit 0

### Legend:

R = Readable bit                      W = Writable bit                      U = Unimplemented bit, read as '0'  
 -n = Value at POR                      '1' = Bit is set                      '0' = Bit is cleared                      x = Bit is unknown

- bit 15-14      **Unimplemented:** Read as '0'
- bit 13-8      **RP67R[5:0]:** Peripheral Output Function is Assigned to RP67 Output Pin bits  
 (see [Table 8-7](#) for peripheral function numbers)
- bit 7-6      **Unimplemented:** Read as '0'
- bit 5-0      **RP66R[5:0]:** Peripheral Output Function is Assigned to RP66 Output Pin bits  
 (see [Table 8-7](#) for peripheral function numbers)

# dsPIC33CK256MP508 FAMILY

## REGISTER 8-72: RPOR18: PERIPHERAL PIN SELECT OUTPUT REGISTER 18

U-0	U-0	R/W-0	R/W-0	R/W-0	R/W-0	R/W-0	R/W-0
—	—	RP69R5	RP69R4	RP69R3	RP69R2	RP69R1	RP69R0
bit 15							bit 8

U-0	U-0	R/W-0	R/W-0	R/W-0	R/W-0	R/W-0	R/W-0
—	—	RP68R5	RP68R4	RP68R3	RP68R2	RP68R1	RP68R0
bit 7							bit 0

### Legend:

R = Readable bit                      W = Writable bit                      U = Unimplemented bit, read as '0'  
 -n = Value at POR                      '1' = Bit is set                      '0' = Bit is cleared                      x = Bit is unknown

- bit 15-14        **Unimplemented:** Read as '0'
- bit 13-8        **RP69R[5:0]:** Peripheral Output Function is Assigned to RP69 Output Pin bits  
 (see [Table 8-7](#) for peripheral function numbers)
- bit 7-6         **Unimplemented:** Read as '0'
- bit 5-0         **RP68R[5:0]:** Peripheral Output Function is Assigned to RP68 Output Pin bits  
 (see [Table 8-7](#) for peripheral function numbers)

## REGISTER 8-73: RPOR19: PERIPHERAL PIN SELECT OUTPUT REGISTER 19

U-0	U-0	R/W-0	R/W-0	R/W-0	R/W-0	R/W-0	R/W-0
—	—	RP71R5	RP71R4	RP71R3	RP71R2	RP71R1	RP71R0
bit 15							bit 8

U-0	U-0	R/W-0	R/W-0	R/W-0	R/W-0	R/W-0	R/W-0
—	—	RP70R5	RP70R4	RP70R3	RP70R2	RP70R1	RP70R0
bit 7							bit 0

### Legend:

R = Readable bit                      W = Writable bit                      U = Unimplemented bit, read as '0'  
 -n = Value at POR                      '1' = Bit is set                      '0' = Bit is cleared                      x = Bit is unknown

- bit 15-14        **Unimplemented:** Read as '0'
- bit 13-8        **RP71R[5:0]:** Peripheral Output Function is Assigned to RP71 Output Pin bits  
 (see [Table 8-7](#) for peripheral function numbers)
- bit 7-6         **Unimplemented:** Read as '0'
- bit 5-0         **RP70R[5:0]:** Peripheral Output Function is Assigned to RP70 Output Pin bits  
 (see [Table 8-7](#) for peripheral function numbers)

# dsPIC33CK256MP508 FAMILY

## REGISTER 8-74: RPOR20: PERIPHERAL PIN SELECT OUTPUT REGISTER 20

U-0	U-0	R/W-0	R/W-0	R/W-0	R/W-0	R/W-0	R/W-0
—	—	RP73R5	RP73R4	RP73R3	RP73R2	RP73R1	RP73R0
bit 15							bit 8

U-0	U-0	R/W-0	R/W-0	R/W-0	R/W-0	R/W-0	R/W-0
—	—	RP72R5	RP72R4	RP72R3	RP72R2	RP72R1	RP72R0
bit 7							bit 0

### Legend:

R = Readable bit                      W = Writable bit                      U = Unimplemented bit, read as '0'  
 -n = Value at POR                      '1' = Bit is set                      '0' = Bit is cleared                      x = Bit is unknown

- bit 15-14      **Unimplemented:** Read as '0'
- bit 13-8      **RP73R[5:0]:** Peripheral Output Function is Assigned to RP73 Output Pin bits  
 (see [Table 8-7](#) for peripheral function numbers)
- bit 7-6      **Unimplemented:** Read as '0'
- bit 5-0      **RP72R[5:0]:** Peripheral Output Function is Assigned to RP72 Output Pin bits  
 (see [Table 8-7](#) for peripheral function numbers)

## REGISTER 8-75: RPOR21: PERIPHERAL PIN SELECT OUTPUT REGISTER 21

U-0	U-0	R/W-0	R/W-0	R/W-0	R/W-0	R/W-0	R/W-0
—	—	RP75R5	RP75R4	RP75R3	RP75R2	RP75R1	RP75R0
bit 15							bit 8

U-0	U-0	R/W-0	R/W-0	R/W-0	R/W-0	R/W-0	R/W-0
—	—	RP74R5	RP74R4	RP74R3	RP74R2	RP74R1	RP74R0
bit 7							bit 0

### Legend:

R = Readable bit                      W = Writable bit                      U = Unimplemented bit, read as '0'  
 -n = Value at POR                      '1' = Bit is set                      '0' = Bit is cleared                      x = Bit is unknown

- bit 15-14      **Unimplemented:** Read as '0'
- bit 13-8      **RP75R[5:0]:** Peripheral Output Function is Assigned to RP75 Output Pin bits  
 (see [Table 8-7](#) for peripheral function numbers)
- bit 7-6      **Unimplemented:** Read as '0'
- bit 5-0      **RP74R[5:0]:** Peripheral Output Function is Assigned to RP74 Output Pin bits  
 (see [Table 8-7](#) for peripheral function numbers)

# dsPIC33CK256MP508 FAMILY

## REGISTER 8-76: RPOR22: PERIPHERAL PIN SELECT OUTPUT REGISTER 22

U-0	U-0	R/W-0	R/W-0	R/W-0	R/W-0	R/W-0	R/W-0
—	—	RP77R5	RP77R4	RP77R3	RP77R2	RP77R1	RP77R0
bit 15							bit 8

U-0	U-0	R/W-0	R/W-0	R/W-0	R/W-0	R/W-0	R/W-0
—	—	RP76R5	RP76R4	RP76R3	RP76R2	RP76R1	RP76R0
bit 7							bit 0

### Legend:

R = Readable bit                      W = Writable bit                      U = Unimplemented bit, read as '0'  
 -n = Value at POR                      '1' = Bit is set                      '0' = Bit is cleared                      x = Bit is unknown

- bit 15-14        **Unimplemented:** Read as '0'
- bit 13-8        **RP77R[5:0]:** Peripheral Output Function is Assigned to RP77 Output Pin bits  
                   (see [Table 8-7](#) for peripheral function numbers)
- bit 7-6         **Unimplemented:** Read as '0'
- bit 5-0         **RP76R[5:0]:** Peripheral Output Function is Assigned to RP76 Output Pin bits  
                   (see [Table 8-7](#) for peripheral function numbers)

## REGISTER 8-77: RPOR23: PERIPHERAL PIN SELECT OUTPUT REGISTER 23

U-0	U-0	R/W-0	R/W-0	R/W-0	R/W-0	R/W-0	R/W-0
—	—	RP79R5	RP79R4	RP79R3	RP79R2	RP79R1	RP79R0
bit 15							bit 8

U-0	U-0	R/W-0	R/W-0	R/W-0	R/W-0	R/W-0	R/W-0
—	—	RP78R5	RP78R4	RP78R3	RP78R2	RP78R1	RP78R0
bit 7							bit 0

### Legend:

R = Readable bit                      W = Writable bit                      U = Unimplemented bit, read as '0'  
 -n = Value at POR                      '1' = Bit is set                      '0' = Bit is cleared                      x = Bit is unknown

- bit 15-14        **Unimplemented:** Read as '0'
- bit 13-8        **RP79R[5:0]:** Peripheral Output Function is Assigned to RP79 Output Pin bits  
                   (see [Table 8-7](#) for peripheral function numbers)
- bit 7-6         **Unimplemented:** Read as '0'
- bit 5-0         **RP78R[5:0]:** Peripheral Output Function is Assigned to RP78 Output Pin bits  
                   (see [Table 8-7](#) for peripheral function numbers)

# dsPIC33CK256MP508 FAMILY

## REGISTER 8-78: RPOR24: PERIPHERAL PIN SELECT OUTPUT REGISTER 24

U-0	U-0	R/W-0	R/W-0	R/W-0	R/W-0	R/W-0	R/W-0
—	—	RP177R5 <sup>(1)</sup>	RP177R4 <sup>(1)</sup>	RP177R3 <sup>(1)</sup>	RP177R2 <sup>(1)</sup>	RP177R1 <sup>(1)</sup>	RP177R0 <sup>(1)</sup>
bit 15							bit 8

U-0	U-0	R/W-0	R/W-0	R/W-0	R/W-0	R/W-0	R/W-0
—	—	RP176R5 <sup>(1)</sup>	RP176R4 <sup>(1)</sup>	RP176R3 <sup>(1)</sup>	RP176R2 <sup>(1)</sup>	RP176R1 <sup>(1)</sup>	RP176R0 <sup>(1)</sup>
bit 7							bit 0

### Legend:

R = Readable bit                      W = Writable bit                      U = Unimplemented bit, read as '0'  
 -n = Value at POR                      '1' = Bit is set                      '0' = Bit is cleared                      x = Bit is unknown

- bit 15-14      **Unimplemented:** Read as '0'
- bit 13-8      **RP177R[5:0]:** Peripheral Output Function is Assigned to RP177 Output Pin bits<sup>(1)</sup>  
                   (see [Table 8-7](#) for peripheral function numbers)
- bit 7-6        **Unimplemented:** Read as '0'
- bit 5-0        **RP176R[5:0]:** Peripheral Output Function is Assigned to RP176 Output Pin bits<sup>(1)</sup>  
                   (see [Table 8-7](#) for peripheral function numbers)

**Note 1:** These are virtual output ports.

## REGISTER 8-79: RPOR25: PERIPHERAL PIN SELECT OUTPUT REGISTER 25

U-0	U-0	R/W-0	R/W-0	R/W-0	R/W-0	R/W-0	R/W-0
—	—	RP179R5 <sup>(1)</sup>	RP179R4 <sup>(1)</sup>	RP179R3 <sup>(1)</sup>	RP179R2 <sup>(1)</sup>	RP179R1 <sup>(1)</sup>	RP179R0 <sup>(1)</sup>
bit 15							bit 8

U-0	U-0	R/W-0	R/W-0	R/W-0	R/W-0	R/W-0	R/W-0
—	—	RP178R5 <sup>(1)</sup>	RP178R4 <sup>(1)</sup>	RP178R3 <sup>(1)</sup>	RP178R2 <sup>(1)</sup>	RP178R1 <sup>(1)</sup>	RP178R0 <sup>(1)</sup>
bit 7							bit 0

### Legend:

R = Readable bit                      W = Writable bit                      U = Unimplemented bit, read as '0'  
 -n = Value at POR                      '1' = Bit is set                      '0' = Bit is cleared                      x = Bit is unknown

- bit 15-14      **Unimplemented:** Read as '0'
- bit 13-8      **RP179R[5:0]:** Peripheral Output Function is Assigned to RP179 Output Pin bits<sup>(1)</sup>  
                   (see [Table 8-7](#) for peripheral function numbers)
- bit 7-6        **Unimplemented:** Read as '0'
- bit 5-0        **RP178R[5:0]:** Peripheral Output Function is Assigned to RP178 Output Pin bits<sup>(1)</sup>  
                   (see [Table 8-7](#) for peripheral function numbers)

**Note 1:** These are virtual output ports.

# dsPIC33CK256MP508 FAMILY

## REGISTER 8-80: RPOR26: PERIPHERAL PIN SELECT OUTPUT REGISTER 26

U-0	U-0	R/W-0	R/W-0	R/W-0	R/W-0	R/W-0	R/W-0
—	—	RP181R5 <sup>(1)</sup>	RP181R4 <sup>(1)</sup>	RP181R3 <sup>(1)</sup>	RP181R2 <sup>(1)</sup>	RP181R1 <sup>(1)</sup>	RP181R0 <sup>(1)</sup>
bit 15							bit 8

U-0	U-0	R/W-0	R/W-0	R/W-0	R/W-0	R/W-0	R/W-0
—	—	RP180R5 <sup>(1)</sup>	RP180R4 <sup>(1)</sup>	RP180R3 <sup>(1)</sup>	RP180R2 <sup>(1)</sup>	RP180R1 <sup>(1)</sup>	RP180R0 <sup>(1)</sup>
bit 7							bit 0

### Legend:

R = Readable bit	W = Writable bit	U = Unimplemented bit, read as '0'
-n = Value at POR	'1' = Bit is set	'0' = Bit is cleared      x = Bit is unknown

bit 15-14      **Unimplemented:** Read as '0'

bit 13-8      **RP181R[5:0]:** Peripheral Output Function is Assigned to RP181 Output Pin bits  
(see [Table 8-7](#) for peripheral function numbers)

bit 7-6      **Unimplemented:** Read as '0'

bit 5-0      **RP180R[5:0]:** Peripheral Output Function is Assigned to RP180 Output Pin bits  
(see [Table 8-7](#) for peripheral function numbers)

**Note 1:** These are virtual output ports.

**TABLE 8-13: PPS INPUT CONTROL REGISTERS**

Register	Bit 15	Bit 14	Bit 13	Bit 12	Bit 11	Bit 10	Bit 9	Bit 8	Bit 7	Bit 6	Bit 5	Bit 4	Bit 3	Bit 2	Bit 1	Bit 0
RPCON	—	—	—	—	IOLOCK	—	—	—	—	—	—	—	—	—	—	—
RPINR0	INT1R7	INT1R6	INT1R5	INT1R4	INT1R3	INT1R2	INT1R1	INT1R0	—	—	—	—	—	—	—	—
RPINR1	INT3R7	INT3R6	INT3R5	INT3R4	INT3R3	INT3R2	INT3R1	INT3R0	INT2R7	INT2R6	INT2R5	INT2R4	INT2R3	INT2R2	INT2R1	INT2R0
RPINR2	T1CKR7	T1CKR6	T1CKR5	T1CKR4	T1CKR3	T1CKR2	T1CKR1	T1CKR0	—	—	—	—	—	—	—	—
RPINR3	ICM1R7	ICM1R6	ICM1R5	ICM1R4	ICM1R3	ICM1R2	ICM1R1	ICM1R0	TCKI1R7	TCKI1R6	TCKI1R5	TCKI1R4	TCKI1R3	TCKI1R2	TCKI1R1	TCKI1R0
RPINR4	ICM2R7	ICM2R6	ICM2R5	ICM2R4	ICM2R3	ICM2R2	ICM2R1	ICM2R0	TCKI2R7	TCKI2R6	TCKI2R5	TCKI2R4	TCKI2R3	TCKI2R2	TCKI2R1	TCKI2R0
RPINR5	ICM3R7	ICM3R6	ICM3R5	ICM3R4	ICM3R3	ICM3R2	ICM3R1	ICM3R0	TCKI3R7	TCKI3R6	TCKI3R5	TCKI3R4	TCKI3R3	TCKI3R2	TCKI3R1	TCKI3R0
RPINR6	ICM4R7	ICM4R6	ICM4R5	ICM4R4	ICM4R3	ICM4R2	ICM4R1	ICM4R0	TCKI4R7	TCKI4R6	TCKI4R5	TCKI4R4	TCKI4R3	TCKI4R2	TCKI4R1	TCKI4R0
RPINR7	ICM5R7	ICM5R6	ICM5R5	ICM5R4	ICM5R3	ICM5R2	ICM5R1	ICM5R0	TCKI5R7	TCKI5R6	TCKI5R5	TCKI5R4	TCKI5R3	TCKI5R2	TCKI5R1	TCKI5R0
RPINR8	ICM6R7	ICM6R6	ICM6R5	ICM6R4	ICM6R3	ICM6R2	ICM6R1	ICM6R0	TCKI6R7	TCKI6R6	TCKI6R5	TCKI6R4	TCKI6R3	TCKI6R2	TCKI6R1	TCKI6R0
RPINR9	ICM7R7	ICM7R6	ICM7R5	ICM7R4	ICM7R3	ICM7R2	ICM7R1	ICM7R0	TCKI7R7	TCKI7R6	TCKI7R5	TCKI7R4	TCKI7R3	TCKI7R2	TCKI7R1	TCKI7R0
RPINR10	ICM8R7	ICM8R6	ICM8R5	ICM8R4	ICM8R3	ICM8R2	ICM8R1	ICM8R0	TCKI8R7	TCKI8R6	TCKI8R5	TCKI8R4	TCKI8R3	TCKI8R2	TCKI8R1	TCKI8R0
RPINR11	OCFBR7	OCFBR6	OCFBR5	OCFBR4	OCFBR3	OCFBR2	OCFBR1	OCFBR0	OCFAR7	OCFAR6	OCFAR5	OCFAR4	OCFAR3	OCFAR2	OCFAR1	OCFAR0
RPINR12	PCI9R7	PCI9R6	PCI9R5	PCI9R4	PCI9R3	PCI9R2	PCI9R1	PCI9R0	PCI8R7	PCI8R6	PCI8R5	PCI8R4	PCI8R3	PCI8R2	PCI8R1	PCI8R0
RPINR13	PCI11R7	PCI11R6	PCI11R5	PCI11R4	PCI11R3	PCI11R2	PCI11R1	PCI11R0	PCI10R7	PCI10R6	PCI10R5	PCI10R4	PCI10R3	PCI10R2	PCI10R1	PCI10R0
RPINR14	QEIB1R7	QEIB1R6	QEIB1R5	QEIB1R4	QEIB1R3	QEIB1R2	QEIB1R1	QEIB1R0	QEIA1R7	QEIA1R6	QEIA1R5	QEIA1R4	QEIA1R3	QEIA1R2	QEIA1R1	QEIA1R0
RPINR15	QEIHM1R7	QEIHM1R6	QEIHM1R5	QEIHM1R4	QEIHM1R3	QEIHM1R2	QEIHM1R1	QEIHM1R0	QEINDX1R7	QEINDX1R6	QEINDX1R5	QEINDX1R4	QEINDX1R3	QEINDX1R2	QEINDX1R1	QEINDX1R0
RPINR16	QEIB2R7	QEIB2R6	QEIB2R5	QEIB2R4	QEIB2R3	QEIB2R2	QEIB2R1	QEIB2R0	QEIA2R7	QEIA2R6	QEIA2R5	QEIA2R4	QEIA2R3	QEIA2R2	QEIA2R1	QEIA2R0
RPINR17	QEIHM2R7	QEIHM2R6	QEIHM2R5	QEIHM2R4	QEIHM2R3	QEIHM2R2	QEIHM2R1	QEIHM2R0	QEINDX2R7	QEINDX2R6	QEINDX2R5	QEINDX2R4	QEINDX2R3	QEINDX2R2	QEINDX2R1	QEINDX2R0
RPINR18	U1DSRR7	U1DSRR6	U1DSRR5	U1DSRR4	U1DSRR3	U1DSRR2	U1DSRR1	U1DSRR0	U1RXR7	U1RXR6	U1RXR5	U1RXR4	U1RXR3	U1RXR2	U1RXR1	U1RXR0
RPINR19	U2DSRR7	U2DSRR6	U2DSRR5	U2DSRR4	U2DSRR3	U2DSRR2	U2DSRR1	U2DSRR0	U2RXR7	U2RXR6	U2RXR5	U2RXR4	U2RXR3	U2RXR2	U2RXR1	U2RXR0
RPINR20	SCK1R7	SCK1R6	SCK1R5	SCK1R4	SCK1R3	SCK1R2	SCK1R1	SCK1R0	SDI1R7	SDI1R6	SDI1R5	SDI1R4	SDI1R3	SDI1R2	SDI1R1	SDI1R0
RPINR21	REFOIR7	REFOIR6	REFOIR5	REFOIR4	REFOIR3	REFOIR2	REFOIR1	REFOIR0	SS1R7	SS1R6	SS1R5	SS1R4	SS1R3	SS1R2	SS1R1	SS1R0
RPINR22	SCK2R7	SCK2R6	SCK2R5	SCK2R4	SCK2R3	SCK2R2	SCK2R1	SCK2R0	SDI2R7	SDI2R6	SDI2R5	SDI2R4	SDI2R3	SDI2R2	SDI2R1	SDI2R0
RPINR23	—	—	—	—	—	—	—	—	SS2R7	SS2R6	SS2R5	SS2R4	SS2R3	SS2R2	SS2R1	SS2R0
RPINR26	—	—	—	—	—	—	—	—	CAN1RXR7	CAN1RXR6	CAN1RXR5	CAN1RXR4	CAN1RXR3	CAN1RXR2	CAN1RXR1	CAN1RXR0
RPINR27	U3DSRR7	U3DSRR6	U3DSRR5	U3DSRR4	U3DSRR3	U3DSRR2	U3DSRR1	U3DSRR0	U3RXR7	U3RXR6	U3RXR5	U3RXR4	U3RXR3	U3RXR2	U3RXR1	U3RXR0
RPINR29	SCK3R7	SCK3R6	SCK3R5	SCK3R4	SCK3R3	SCK3R2	SCK3R1	SCK3R0	SDI3R7	SDI3R6	SDI3R5	SDI3R4	SDI3R3	SDI3R2	SDI3R1	SDI3R0
RPINR30	—	—	—	—	—	—	—	—	SS3R7	SS3R6	SS3R5	SS3R4	SS3R3	SS3R2	SS3R1	SS3R0
RPINR32	TCKI9R7	TCKI9R6	TCKI9R5	TCKI9R4	TCKI9R3	TCKI9R2	TCKI9R1	TCKI9R0	—	—	—	—	—	—	—	—
RPINR33	—	—	—	—	—	—	—	—	ICM9R7	ICM9R6	ICM9R5	ICM9R4	ICM9R3	ICM9R2	ICM9R1	ICM9R0
RPINR37	PCI17R7	PCI17R6	PCI17R5	PCI17R4	PCI17R3	PCI17R2	PCI17R1	PCI17R0	OCFCR7	OCFCR6	OCFCR5	OCFCR4	OCFCR3	OCFCR2	OCFCR1	OCFCR0
RPINR38	—	—	—	—	—	—	—	—	PCI18R7	PCI18R6	PCI18R5	PCI18R4	PCI18R3	PCI18R2	PCI18R1	PCI18R0
RPINR42	PCI13R7	PCI13R6	PCI13R5	PCI13R4	PCI13R3	PCI13R2	PCI13R1	PCI13R0	PCI12R7	PCI12R6	PCI12R5	PCI12R4	PCI12R3	PCI12R2	PCI12R1	PCI12R0
RPINR43	PCI15R7	PCI15R6	PCI15R5	PCI15R4	PCI15R3	PCI15R2	PCI15R1	PCI15R0	PCI14R7	PCI14R6	PCI14R5	PCI14R4	PCI14R3	PCI14R2	PCI14R1	PCI14R0
RPINR44	SENT1R7	SENT1R6	SENT1R5	SENT1R4	SENT1R3	SENT1R2	SENT1R1	SENT1R0	PCI16R7	PCI16R6	PCI16R5	PCI16R4	PCI16R3	PCI16R2	PCI16R1	PCI16R0
RPINR45	CLCINAR7	CLCINAR6	CLCINAR5	CLCINAR4	CLCINAR3	CLCINAR2	CLCINAR1	CLCINAR0	SENT2R7	SENT2R6	SENT2R5	SENT2R4	SENT2R3	SENT2R2	SENT2R1	SENT2R0
RPINR46	CLCINCR7	CLCINCR6	CLCINCR5	CLCINCR4	CLCINCR3	CLCINCR2	CLCINCR1	CLCINCR0	CLCINBR7	CLCINBR6	CLCINBR5	CLCINBR4	CLCINBR3	CLCINBR2	CLCINBR1	CLCINBR0
RPINR47	ADCTRGR7	ADCTRGR6	ADCTRGR5	ADCTRGR4	ADCTRGR3	ADCTRGR2	ADCTRGR1	ADCTRGR0	CLCINDR7	CLCINDR6	CLCINDR5	CLCINDR4	CLCINDR3	CLCINDR2	CLCINDR1	CLCINDR0
RPINR48	U1CTSR7	U1CTSR6	U1CTSR5	U1CTSR4	U1CTSR3	U1CTSR2	U1CTSR1	U1CTSR0	OCFDR7	OCFDR6	OCFDR5	OCFDR4	OCFDR3	OCFDR2	OCFDR1	OCFDR0
RPINR49	U3CTSR7	U3CTSR6	U3CTSR5	U3CTSR4	U3CTSR3	U3CTSR2	U3CTSR1	U3CTSR0	U2CTSR7	U2CTSR6	U2CTSR5	U2CTSR4	U2CTSR3	U2CTSR2	U2CTSR1	U2CTSR0

**TABLE 8-14: PPS OUTPUT CONTROL REGISTERS**

Register	Bit 15	Bit 14	Bit 13	Bit 12	Bit 11	Bit 10	Bit 9	Bit 8	Bit 7	Bit 6	Bit 5	Bit 4	Bit 3	Bit 2	Bit 1	Bit 0
RPOR0	—	—	RP33R5	RP33R4	RP33R3	RP33R2	RP33R1	RP33R0	—	—	RP32R5	RP32R4	RP32R3	RP32R2	RP32R1	RP32R0
RPOR1	—	—	RP35R5	RP35R4	RP35R3	RP35R2	RP35R1	RP35R0	—	—	RP34R5	RP34R4	RP34R3	RP34R2	RP34R1	RP34R0
RPOR2	—	—	RP37R5	RP37R4	RP37R3	RP37R2	RP37R1	RP37R0	—	—	RP36R5	RP36R4	RP36R3	RP36R2	RP36R1	RP36R0
RPOR3	—	—	RP39R5	RP39R4	RP39R3	RP39R2	RP39R1	RP39R0	—	—	RP38R5	RP38R4	RP38R3	RP38R2	RP38R1	RP38R0
RPOR4	—	—	RP41R5	RP41R4	RP41R3	RP41R2	RP41R1	RP41R0	—	—	RP40R5	RP40R4	RP40R3	RP40R2	RP40R1	RP40R0
RPOR5	—	—	RP43R5	RP43R4	RP43R3	RP43R2	RP43R1	RP43R0	—	—	RP42R5	RP42R4	RP42R3	RP42R2	RP42R1	RP42R0
RPOR6	—	—	RP45R5	RP45R4	RP45R3	RP45R2	RP45R1	RP45R0	—	—	RP44R5	RP44R4	RP44R3	RP44R2	RP44R1	RP44R0
RPOR7	—	—	RP47R5	RP47R4	RP47R3	RP47R2	RP47R1	RP47R0	—	—	RP46R5	RP46R4	RP46R3	RP46R2	RP46R1	RP46R0
RPOR8 <sup>(1)</sup>	—	—	RP49R5	RP49R4	RP49R3	RP49R2	RP49R1	RP49R0	—	—	RP48R5	RP48R4	RP48R3	RP48R2	RP48R1	RP48R0
RPOR9 <sup>(1)</sup>	—	—	RP51R5	RP51R4	RP51R3	RP51R2	RP51R1	RP51R0	—	—	RP50R5	RP50R4	RP50R3	RP50R2	RP50R1	RP50R0
RPOR10 <sup>(1)</sup>	—	—	RP53R5	RP53R4	RP53R3	RP53R2	RP53R1	RP53R0	—	—	RP52R5	RP52R4	RP52R3	RP52R2	RP52R1	RP52R0
RPOR11 <sup>(1)</sup>	—	—	RP55R5	RP55R4	RP55R3	RP55R2	RP55R1	RP55R0	—	—	RP54R5	RP54R4	RP54R3	RP54R2	RP54R1	RP54R0
RPOR12 <sup>(1)</sup>	—	—	RP57R5	RP57R4	RP57R3	RP57R2	RP57R1	RP57R0	—	—	RP56R5	RP56R4	RP56R3	RP56R2	RP56R1	RP56R0
RPOR13 <sup>(1)</sup>	—	—	RP59R5	RP59R4	RP59R3	RP59R2	RP59R1	RP59R0	—	—	RP58R5	RP58R4	RP58R3	RP58R2	RP58R1	RP58R0
RPOR14 <sup>(1)</sup>	—	—	RP61R5	RP61R4	RP61R3	RP61R2	RP61R1	RP61R0	—	—	RP60R5	RP60R4	RP60R3	RP60R2	RP60R1	RP60R0
RPOR15 <sup>(1)</sup>	—	—	RP63R5	RP63R4	RP63R3	RP63R2	RP63R1	RP63R0	—	—	RP62R5	RP62R4	RP62R3	RP62R2	RP62R1	RP62R0
RPOR16 <sup>(1)</sup>	—	—	RP65R5	RP65R4	RP65R3	RP65R2	RP65R1	RP65R0	—	—	RP64R5	RP64R4	RP64R3	RP64R2	RP64R1	RP64R0
RPOR17 <sup>(1)</sup>	—	—	RP67R5	RP67R4	RP67R3	RP67R2	RP67R1	RP67R0	—	—	RP66R5	RP66R4	RP66R3	RP66R2	RP66R1	RP66R0
RPOR18 <sup>(1)</sup>	—	—	RP69R5	RP69R4	RP69R3	RP69R2	RP69R1	RP69R0	—	—	RP68R5	RP68R4	RP68R3	RP68R2	RP68R1	RP68R0
RPOR19 <sup>(1)</sup>	—	—	RP71R5	RP71R4	RP71R3	RP71R2	RP71R1	RP71R0	—	—	RP70R5	RP70R4	RP70R3	RP70R2	RP70R1	RP70R0
RPOR20 <sup>(1)</sup>	—	—	RP73R5	RP73R4	RP73R3	RP73R2	RP73R1	RP73R0	—	—	RP72R5	RP72R4	RP72R3	RP72R2	RP72R1	RP72R0
RPOR21 <sup>(1)</sup>	—	—	RP75R5	RP75R4	RP75R3	RP75R2	RP75R1	RP75R0	—	—	RP74R5	RP74R4	RP74R3	RP74R2	RP74R1	RP74R0
RPOR22 <sup>(1)</sup>	—	—	RP77R5	RP77R4	RP77R3	RP77R2	RP77R1	RP77R0	—	—	RP76R5	RP76R4	RP76R3	RP76R2	RP76R1	RP76R0
RPOR23 <sup>(1)</sup>	—	—	RP79R5	RP79R4	RP79R3	RP79R2	RP79R1	RP79R0	—	—	RP78R5	RP78R4	RP78R3	RP78R2	RP78R1	RP78R0
RPOR24	—	—	RP177R5	RP177R4	RP177R3	RP177R2	RP177R1	RP177R0	—	—	RP176R5	RP176R4	RP176R3	RP176R2	RP176R1	RP176R0
RPOR25	—	—	RP179R5	RP179R4	RP179R3	RP179R2	RP179R1	RP179R0	—	—	RP178R5	RP178R4	RP178R3	RP178R2	RP178R1	RP178R0
RPOR26	—	—	RP181R5	RP181R4	RP181R3	RP181R2	RP181R1	RP181R0	—	—	RP180R5	RP180R4	RP180R3	RP180R2	RP180R1	RP180R0

**Note 1:** Availability is dependent on supported I/O ports. Refer to [Table 8-1](#) and [Table 8-6](#) for availability on device variants.



## 9.0 OSCILLATOR WITH HIGH-FREQUENCY PLL

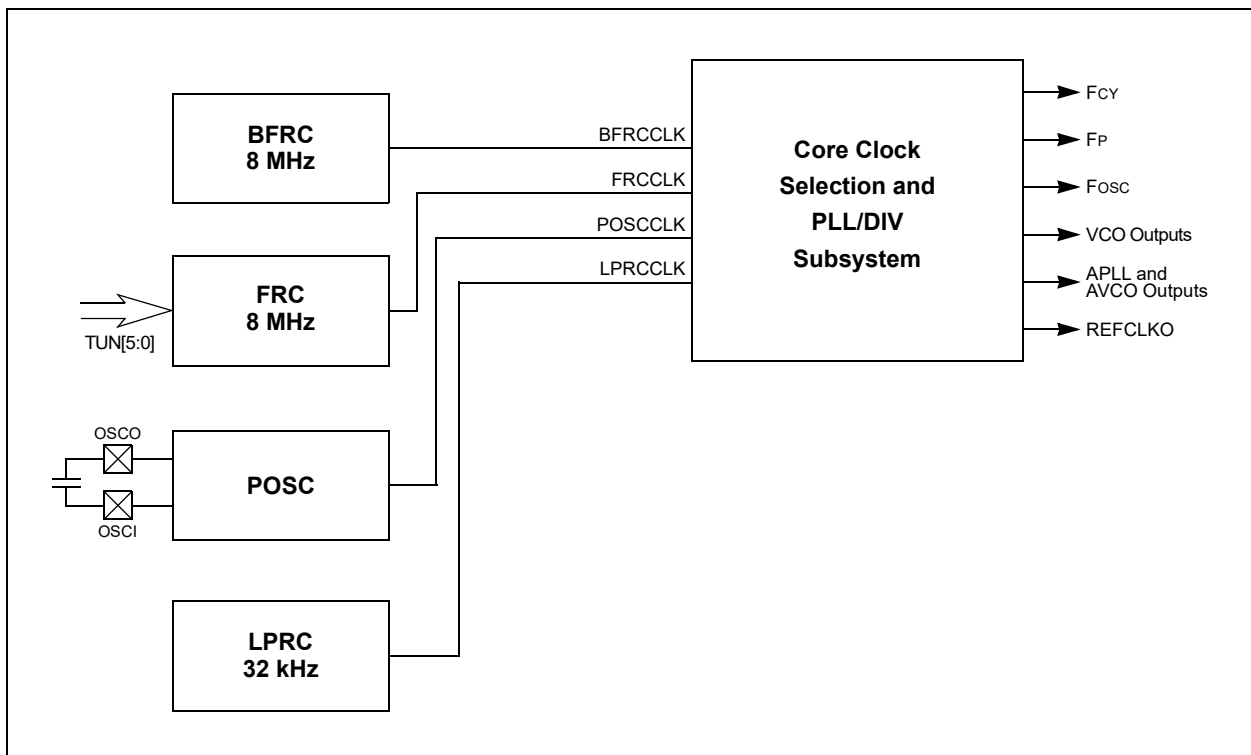
**Note 1:** This data sheet summarizes the features of the dsPIC33CK256MP508 family of devices. It is not intended to be a comprehensive reference source. To complement the information in this data sheet, refer to “Oscillator Module with High-Speed PLL” ([www.microchip.com/DS70005255](http://www.microchip.com/DS70005255)) in the “dsPIC33/PIC24 Family Reference Manual”.

The dsPIC33CK256MP508 family oscillator with high-frequency PLL includes these characteristics:

- On-Chip Phase-Locked Loop (PLL) to Boost Internal Operating Frequency on Select Internal and External Oscillator Sources
- Auxiliary PLL (APLL) Clock Generator to Boost Operating Frequency for Peripherals
- Doze mode for System Power Savings
- Scalable Reference Clock Output (REFCLKO)
- On-the-Fly Clock Switching between Various Clock Sources
- Fail-Safe Clock Monitoring (FSCM) that Detects Clock Failure and Permits Safe Application Recovery or Shutdown

A block diagram of the dsPIC33CK256MP508 oscillator system is shown in [Figure 9-1](#).

**FIGURE 9-1: dsPIC33CK256MP508 CORE CLOCK SOURCES BLOCK DIAGRAM**





# dsPIC33CK256MP508 FAMILY

## 9.1 Primary PLL

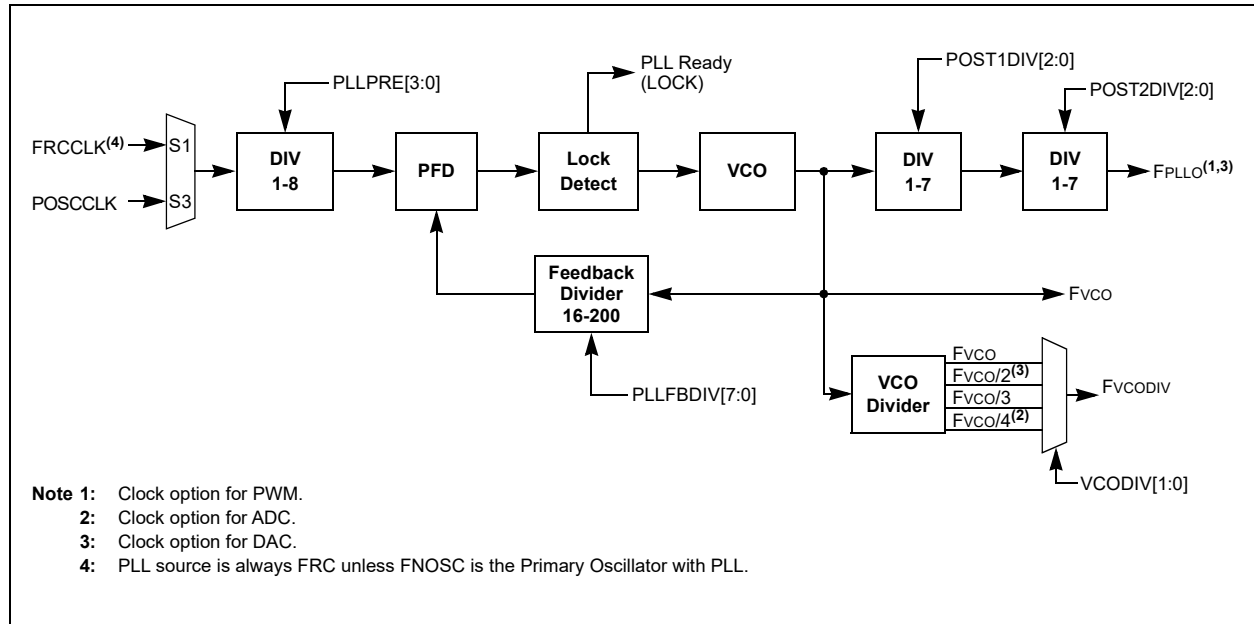
The Primary Oscillator and internal FRC Oscillator sources can optionally use an on-chip PLL to obtain higher operating speeds. Figure 9-3 illustrates a block diagram of the PLL module.

For PLL operation, the following requirements must be met at all times without exception:

- The PLL Input Frequency ( $F_{PLL}$ ) must be in the range of 8 MHz to 64 MHz
- The PFD Input Frequency ( $F_{PFD}$ ) must be in the range of 8 MHz to ( $F_{VCO}/16$ ) MHz

The VCO Output Frequency ( $F_{VCO}$ ) must be in the range of 400 MHz to 1600 MHz.

**FIGURE 9-3: PLL AND VCO DETAIL**



# dsPIC33CK256MP508 FAMILY

Equation 9-1 provides the relationship between the PLL Input Frequency (F<sub>PLLI</sub>) and VCO Output Frequency (F<sub>VCO</sub>).

## EQUATION 9-1: F<sub>VCO</sub> CALCULATION

$$F_{VCO} = F_{PLLI} \times \left(\frac{M}{N1}\right) = F_{PLLI} \times \left(\frac{PLLFBDIV[7:0]}{PLLPRE[3:0]}\right)$$

Equation 9-2 provides the relationship between the PLL Input Frequency (F<sub>PLLI</sub>) and PLL Output Frequency (F<sub>PLLO</sub>).

## EQUATION 9-2: F<sub>PLLO</sub> CALCULATION

$$F_{PLLO} = F_{PLLI} \times \left(\frac{M}{N1 \times N2 \times N3}\right) = F_{PLLI} \times \left(\frac{PLLFBDIV[7:0]}{PLLPRE[3:0] \times POST1DIV[2:0] \times POST2DIV[2:0]}\right)$$

Where:

$M = PLLFBDIV[7:0]$

$N1 = PLLPRE[3:0]$

$N2 = POST1DIV[2:0]$

$N3 = POST2DIV[2:0]$

**Note:** The PLL Phase Detector Input Divider Select (PLLPREx) bits and the PLL Feedback Divider (PLLFBDIVx) bits should not be changed when operating in PLL mode. Therefore, the user must start in either a non-PLL mode or clock switch to a non-PLL mode (e.g., internal FRC Oscillator) to make any necessary changes and then clock switch to the desired PLL mode.

It is not permitted to directly clock switch from one PLL clock source to a different PLL clock source. The user would need to transition between PLL clock sources with a clock switch to a non-PLL clock source.

## EXAMPLE 9-1: CODE EXAMPLE FOR USING PRIMARY PLL WITH 8 MHz INTERNAL FRC

```
//code example for 50 MIPS system clock using 8MHz FRC
// Select FRC on POR
#pragma config FNOSC = FRC           // Oscillator Source Selection (Internal Fast RC (FRC))
#pragma config IESO = OFF
// Enable Clock Switching
#pragma config FCKSM = CSECMD
int    main()
{
// Configure PLL prescaler, both PLL postscalers, and PLL feedback divider
CLKDIVbits.PLLPRE = 1;             // N1=1
PLLFBDbits.PLLFBDIV = 125;        // M = 125
PLLDIVbits.POST1DIV = 5;          // N2=5
PLLDIVbits.POST2DIV = 1;          // N3=1
// Initiate Clock Switch to FRC with PLL (NOSC=0b001)
__builtin_write_OSCCONH(0x01);
__builtin_write_OSCCONL(OSCCON | 0x01);
// Wait for Clock switch to occur
while (OSCCONbits.OSWEN != 0);
}
```

# dsPIC33CK256MP508 FAMILY

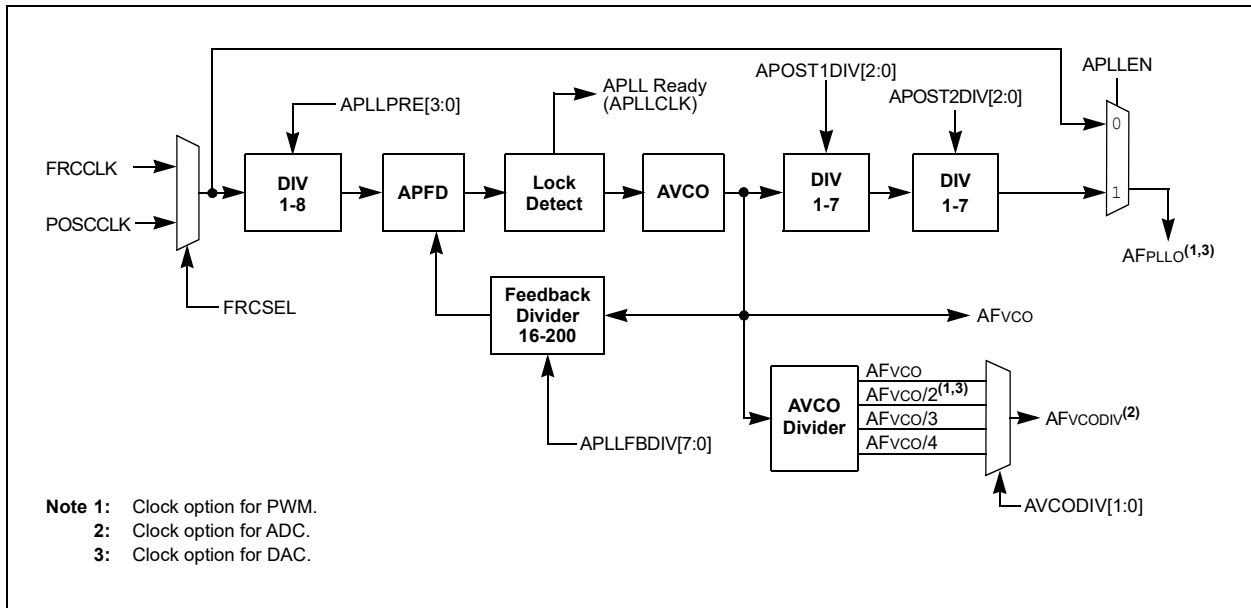
## 9.2 Auxiliary PLL

The dsPIC33CK256MP508 device family implements an Auxiliary PLL (APLL) module, which is used to generate various peripheral clock sources independent of the system clock. Figure 9-4 shows a block diagram of the APLL module.

For APLL operation, the following requirements must be met at all times without exception:

- The APLL Input Frequency (AF<sub>PLL</sub>I) must be in the range of 8 MHz to 64 MHz
- The APFD Input Frequency (AF<sub>PF</sub>D) must be in the range of 8 MHz to (AF<sub>V</sub>CO/16) MHz
- The AVCO Output Frequency (AF<sub>V</sub>CO) must be in the range of 400 MHz to 1600 MHz

**FIGURE 9-4: APLL AND VCO DETAIL**



# dsPIC33CK256MP508 FAMILY

Equation 9-3 provides the relationship between the APLL Input Frequency (AF<sub>PLLI</sub>) and the AVCO Output Frequency (AF<sub>VCO</sub>).

## EQUATION 9-3: AF<sub>VCO</sub> CALCULATION

$$AF_{VCO} = AF_{PLLI} \times \left(\frac{M}{N1}\right) = AF_{PLLI} \times \left(\frac{APLLFBDIV[7:0]}{APLLPRE[3:0]}\right)$$

Equation 9-4 provides the relationship between the APLL Input Frequency (AF<sub>PLLI</sub>) and APLL Output Frequency (AF<sub>PLLO</sub>).

## EQUATION 9-4: AF<sub>PLLO</sub> CALCULATION

$$AF_{PLLO} = AF_{PLLI} \times \left(\frac{M}{N1 \times N2 \times N3}\right) = AF_{PLLI} \times \left(\frac{APLLFBDIV[7:0]}{APLLPRE[3:0] \times APOST1DIV[2:0] \times APOST2DIV[2:0]}\right)$$

Where:

$M = APLLFBDIV[7:0]$

$N1 = APLLPRE[3:0]$

$N2 = APOST1DIV[2:0]$

$N3 = APOST2DIV[2:0]$

## EXAMPLE 9-2: CODE EXAMPLE FOR USING AUXILIARY PLL WITH THE INTERNAL FRC OSCILLATOR

```
//code example for AFVCO = 1 GHz and AFPLLO = 500 MHz using 8 MHz internal FRC
// Configure the source clock for the APLL
ACLKCON1bits.FRCSEL = 1;           // Select internal FRC as the clock source
// Configure the APLL prescaler, APLL feedback divider, and both APLL postscalers.
ACLKCON1bits.APLLPRE = 1;         // N1 = 1
APLLFBD1bits.APLLFBDIV = 125;    // M = 125
APLLDIV1bits.APOST1DIV = 2;      // N2 = 2
APLLDIV1bits.APOST2DIV = 1;      // N3 = 1
// Enable APLL
ACLKCON1bits.APLEN = 1;
```

**Note:** Even with the APLEN bit set, another peripheral must generate a clock request before the APLL will start.

# dsPIC33CK256MP508 FAMILY

## 9.3 CPU Clocking

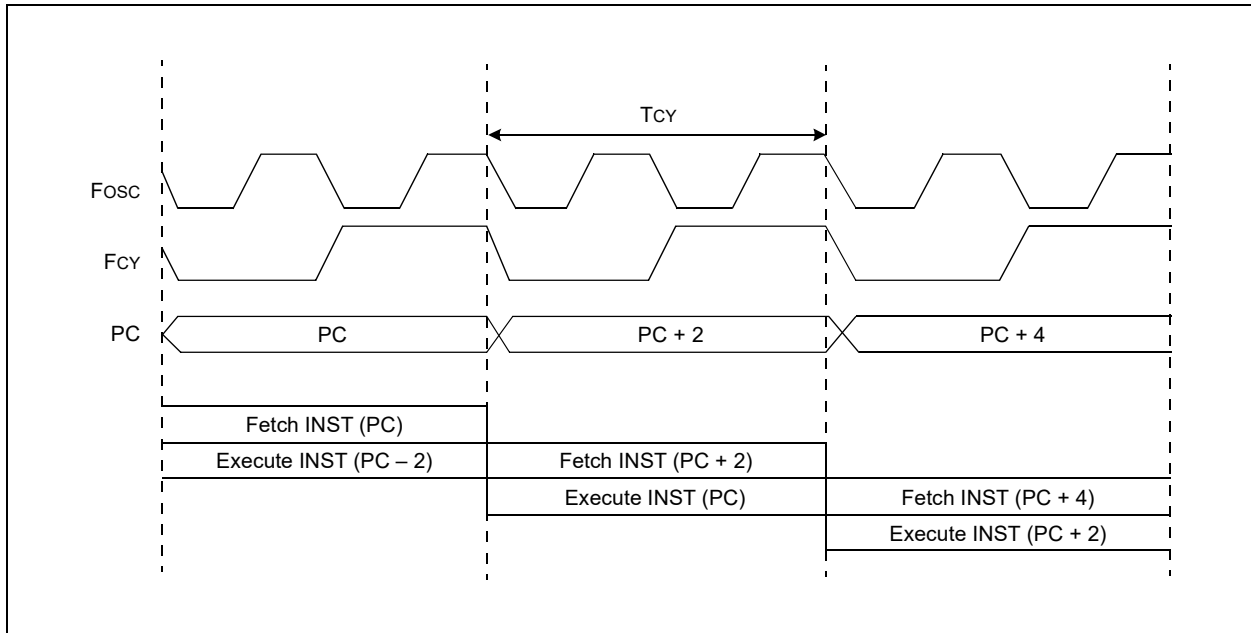
The dsPIC33CK256MP508 devices can be configured to use any of the following clock configurations:

- Primary Oscillator (POSC) on the OSC1 and OSCO pins
- Internal Fast RC Oscillator (FRC) with optional clock divider
- Internal Low-Power RC Oscillator (LPRC)
- Primary Oscillator with PLL (ECPLL, HSPLL, XTPLL)
- Internal Fast RC Oscillator with PLL (FRCPLL)
- Backup Internal Fast RC Oscillator (BFRC)

The system clock source is divided by two to produce the internal instruction cycle clock. In this document, the instruction cycle clock is denoted by F<sub>cy</sub>. The timing diagram in Figure 9-5 illustrates the relationship between the system clock (F<sub>osc</sub>), the instruction cycle clock (F<sub>cy</sub>) and the Program Counter (PC).

The internal instruction cycle clock (F<sub>cy</sub>) can be output on the OSCO I/O pin if the Primary Oscillator mode (POSCMD[1:0]) is not configured as HS/XT. For more information, see Section 9.0 “Oscillator with High-Frequency PLL”.

**FIGURE 9-5: CLOCK AND INSTRUCTION CYCLE TIMING**



# dsPIC33CK256MP508 FAMILY

## 9.4 Primary Oscillator (POSC)

The dsPIC33CK256MP508 family devices feature a Primary Oscillator (POSC) and it is available on the OSCI and OSCO pins. This connection enables an external crystal (or ceramic resonator) to provide the clock to the device. The Primary Oscillator provides three modes of operation:

- Medium Speed Oscillator (XT Mode):  
The XT mode is a Medium Gain, Medium Frequency mode used to work with crystal frequencies of 3.5 MHz to 10 MHz.

- High-Speed Oscillator (HS Mode):  
The HS mode is a High-Gain, High-Frequency mode used to work with crystal frequencies of 10 MHz to 32 MHz.
- External Clock Source Operation (EC Mode):  
If the on-chip oscillator is not used, the EC mode allows the internal oscillator to be bypassed. The device clocks are generated from an external source (0 MHz to up to 64 MHz) and input on the OSCI pin.

**Example 9-3** illustrates code for using the PLL (50 MIPS) with the Primary Oscillator.

### EXAMPLE 9-3: CODE EXAMPLE FOR USING PLL (50 MIPS) WITH PRIMARY OSCILLATOR (POSC)

```
//code example for 50 MIPS system clock using POSC with 10 MHz external crystal

// Select FRC on POR
#pragma config FNOSC = FRC           // Oscillator Source Selection (Internal Fast RC (FRC))
#pragma config IESO = OFF
/// Enable Clock Switching and Configure POSC in XT mode
#pragma config POSCMD = XT
#pragma config FCKSM = CSECMD

int    main()
{
    // Configure PLL prescaler, both PLL postscalers, and PLL feedback divider
    CLKDIVbits.PLLPRE = 1;           // N1=1
    PLLFBDbits.PLLFBDIV = 100;      // M = 100
    PLLDIVbits.POST1DIV = 5;        // N2=5
    PLLDIVbits.POST2DIV = 1;        // N3=1

    // Initiate Clock Switch to Primary Oscillator with PLL (NOSC=0b011)
    __builtin_write_OSCCONH(0x03);
    __builtin_write_OSCCONL(OSCCON | 0x01);

    // Wait for Clock switch to occur
    while (OSCCONbits.OSWEN!= 0);

    // Wait for PLL to lock
    while (OSCCONbits.LOCK!= 1);
}
```

### 9.4.1 PRIMARY OSCILLATOR PIN FUNCTIONALITY

The Primary Oscillator pins (OSCI and OSCO) can be used for other functions when the Primary Oscillator is not being used. The POSCMD[1:0] Configuration bits in the Oscillator Configuration register (FOSC[1:0]) determine the oscillator pin function. The OSCIOFNC bit

(FOSC[2]) determines the OSCO/CLKO pin function. By default, the CLKO function is active and the pin will output a clock frequency of Fcy. A clock signal is present on the OSCO/CLKO pin when the device is unprogrammed or during the programming sequence. Care should be taken when the OSCO/CLKO pin is used to drive other circuitry.



# dsPIC33CK256MP508 FAMILY

## 9.5 Internal Fast RC (FRC) Oscillator

The dsPIC33CK256MP508 family devices contain one instance of the internal Fast RC (FRC) Oscillator and it provides a nominal 8 MHz clock without requiring an external crystal or ceramic resonator, which results in system cost savings for applications that do not require a precise clock reference.

The application software can tune the frequency of the oscillator using the FRC Oscillator Tuning bits (TUN[5:0]) in the FRC Oscillator Tuning register (OSCTUN[5:0]).

## 9.6 Low-Power RC (LPRC) Oscillator

The dsPIC33CK256MP508 family devices contain one instance of the Low-Power RC (LPRC) Oscillator which provides a nominal clock frequency of 32 kHz, and is the clock source for the Watchdog Timer (WDT) and Fail-Safe Clock Monitor (FSCM) circuits in the clock subsystem. The LPRC Oscillator is shut off in Sleep mode.

The LPRC Oscillator remains enabled under these conditions:

- The FSCM is enabled
- The WDT is enabled
- The LPRC Oscillator is selected as the system clock

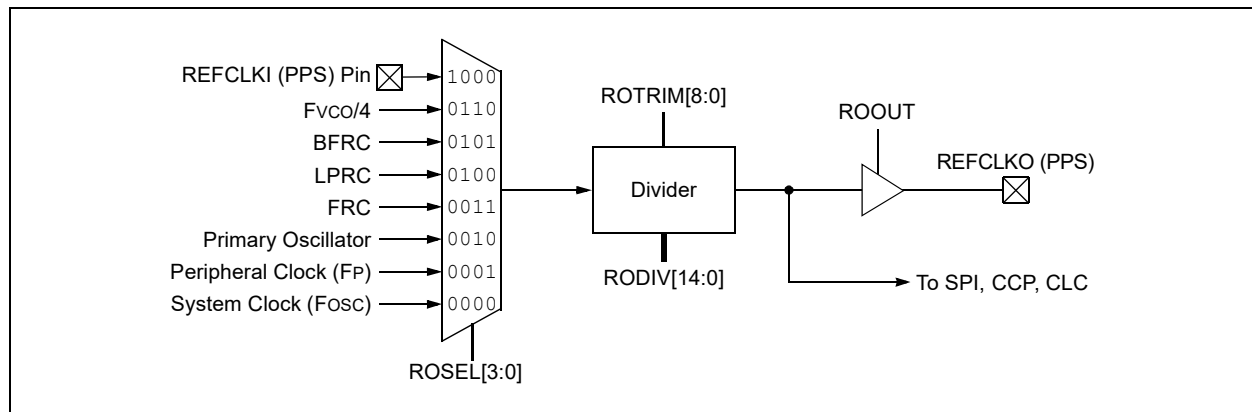
## 9.7 Backup Internal Fast RC (BFRC) Oscillator

The oscillator block provides a stable reference clock source for the Fail-Safe Clock Monitor (FSCM). When FSCM is enabled in the FCKSM[1:0] Configuration bits (FOSC[7:6]), it constantly monitors the main clock source against a reference signal from the 8 MHz Backup Internal Fast RC (BFRC) Oscillator. In case of a clock failure, the Fail-Safe Clock Monitor switches the clock to the BFRC Oscillator, allowing for continued low-speed operation or a safe application shutdown.

## 9.8 Reference Clock Output

In addition to the CLKO output (Fosc/2), the dsPIC33CK256MP508 family devices can be configured to provide a reference clock output signal to a port pin. This feature is available in all oscillator configurations and allows the user to select a greater range of clock sub-multiples to drive external devices in the application. CLKO is enabled by Configuration bit, OSCIOFNC, and is independent of the REFCLKO reference clock. REFCLKO is mappable to any I/O pin that has mapped output capability. Refer to [Table 8-7](#) for more information. The Reference Clock Output module block diagram is shown in [Figure 9-6](#).

**FIGURE 9-6: REFERENCE CLOCK GENERATOR**



# dsPIC33CK256MP508 FAMILY

---

This reference clock output is controlled by the REFOCONL and REFOCONH registers. Setting the ROEN bit (REFOCONL[15]) makes the clock signal available on the REFCLKO pin. The RODIV[14:0] bits (REFOCONH[14:0]) and ROTRIM[8:0] bits (REFOTRIM[15:7]) enable the selection of different clock divider options. The formula for determining the final frequency output is shown in Equation 9-5. The ROSWEN bit (REFOCONL[9]) indicates that the clock divider has been successfully switched. In order to switch the REFCLKO divider, the user should ensure that this bit reads as '0'. Write the updated values to the RODIV[14:0] or ROTRIM[8:0] bits, set the ROSWEN bit and then wait until it is cleared before assuming that the REFCLKO clock is valid.

## EQUATION 9-5: CALCULATING FREQUENCY OUTPUT

$$F_{REFOUT} = \frac{F_{REFIN}}{2 \cdot (RODIV[14:0] + ROTRIM[8:0]/512)}$$

Where:  $F_{REFOUT}$  = Output Frequency  
 $F_{REFIN}$  = Input Frequency  
When  $RODIV[14:0] = 0$ , the output clock is the same as the input clock.

The ROSEL[3:0] bits (REFOCONL[3:0]) determine which clock source is used for the reference clock output. The ROSLP bit (REFOCONL[11]) determines if the reference source is available on REFCLKO when the device is in Sleep mode.

To use the reference clock output in Sleep mode, both the ROSLP bit must be set and the clock selected by the ROSEL[3:0] bits must be enabled for operation during Sleep mode, if possible. Clearing the ROSEL[3:0] bits allows the reference output frequency to change, as the system clock changes, during any clock switches. The ROOUT bit enables/disables the reference clock output on the REFCLKO pin.

The ROACTIV bit (REFOCONL[8]) indicates that the module is active; it can be cleared by disabling the module (setting ROEN to '0'). The user must not change the reference clock source, or adjust the divider when the ROACTIV bit indicates that the module is active. To avoid glitches, the user should not disable the module until the ROACTIV bit is '1'.

# dsPIC33CK256MP508 FAMILY

## 9.9 Oscillator Configuration

The oscillator system has both Configuration registers and SFRs to configure, control and monitor the system. The FOSCSEL and FOSC Configuration registers (Register 30-4 and Register 30-5, respectively) are used for initial setup.

Table 9-1 lists the configuration settings that select the device's oscillator source and operating mode at a Power-on Reset (POR).

**TABLE 9-1: CONFIGURATION BIT VALUES FOR CLOCK SELECTION**

Oscillator Source	Oscillator Mode	FNOSC[2:0] Value	POSCMD[1:0] Value	Notes
S0	Fast RC Oscillator (FRC)	000	xx	1
S1	Fast RC Oscillator with PLL (FRCPLL)	001	xx	1
S2	Primary Oscillator (EC)	010	00	1
S2	Primary Oscillator (XT)	010	01	
S2	Primary Oscillator (HS)	010	10	
S3	Primary Oscillator with PLL (ECPLL)	011	00	1
S3	Primary Oscillator with PLL (XTPLL)	011	01	
S3	Primary Oscillator with PLL (HSPLL)	011	10	
S4	Reserved	100	xx	
S5	Low-Power RC Oscillator (LPRC)	101	xx	1
S6	Backup FRC (BFRC)	110	xx	1
S7	Fast RC Oscillator with ÷ N Divider (FRCDIVN)	111	xx	1, 2

**Note 1:** The OSCO pin function is determined by the OSCIOFNC Configuration bit.

**2:** This is the default oscillator mode for an unprogrammed (erased) device.

## 9.10 OSCCON Unlock Sequence

The OSCCON register is protected against unintended writes through a lock mechanism. The upper and lower bytes of OSCCON have their own unlock sequence, and both must be used when writing to both bytes of the register.

Before OSCCON can be written to, the following unlock sequence must be used:

- Execute the unlock sequence for the OSCCON high byte.  
In two back-to-back instructions:
  - Write 0x78 to OSCCON[15:8]
  - Write 0x9A to OSCCON[15:8]
- In the instruction immediately following the unlock sequence, the OSCCON[10:8] bits can be modified.

- Execute the unlock sequence for the OSCCON low byte.  
In two back-to-back instructions:
  - Write 0x46 to OSCCON[7:0]
  - Write 0x57 to OSCCON[7:0]
- In the instruction immediately following the unlock sequence, the OSCCON[7:0] bits can be modified.

**Note:** MPLAB® XC16 provides built-in C language function for unlocking the OSCCON register:

```
__builtin_write_OSCCONH(value)
__builtin_write_OSCCONL(OSCCON | value)
```

For more information, see the "MPLAB® XC16 C Compiler User's Guide" (DS50002071).

# dsPIC33CK256MP508 FAMILY

## 9.11 Oscillator Control Registers

### REGISTER 9-1: OSCCON: OSCILLATOR CONTROL REGISTER<sup>(1)</sup>

U-0	R-0	R-0	R-0	U-0	R/W-y	R/W-y	R/W-y
—	COSC2	COSC1	COSC0	—	NOSC2 <sup>(2)</sup>	NOSC1 <sup>(2)</sup>	NOSC0 <sup>(2)</sup>
bit 15				bit 8			

R/W-0	U-0	R-0	U-0	R/W-0	U-0	U-0	R/W-0
CLKLOCK	—	LOCK	—	CF <sup>(3)</sup>	—	—	OSWEN
bit 7				bit 0			

<b>Legend:</b>	y = Value set from Configuration bits on POR		
R = Readable bit	W = Writable bit	U = Unimplemented bit, read as '0'	
-n = Value at POR	'1' = Bit is set	'0' = Bit is cleared	x = Bit is unknown

bit 15 **Unimplemented:** Read as '0'

bit 14-12 **COSC[2:0]:** Current Oscillator Selection bits (read-only)

- 111 = Fast RC Oscillator (FRC) with Divide-by-n (FRCDIVN)
- 110 = Backup FRC (BFRC)
- 101 = Low-Power RC Oscillator (LPRC)
- 100 = Reserved – default to FRC
- 011 = Primary Oscillator (XT, HS, EC) with PLL (XTPLL, HSPLL, ECPLL)
- 010 = Primary Oscillator (XT, HS, EC)
- 001 = Fast RC Oscillator (FRC) with PLL (FRCPLL)
- 000 = Fast RC Oscillator (FRC)

bit 11 **Unimplemented:** Read as '0'

bit 10-8 **NOSC[2:0]:** New Oscillator Selection bits<sup>(2)</sup>

- 111 = Fast RC Oscillator (FRC) with Divide-by-n (FRCDIVN)
- 110 = Backup FRC (BFRC)
- 101 = Low-Power RC Oscillator (LPRC)
- 100 = Reserved – default to FRC
- 011 = Primary Oscillator (XT, HS, EC) with PLL (XTPLL, HSPLL, ECPLL)
- 010 = Primary Oscillator (XT, HS, EC)
- 001 = Fast RC Oscillator (FRC) with PLL (FRCPLL)
- 000 = Fast RC Oscillator (FRC)

bit 7 **CLKLOCK:** Clock Lock Enable bit

- 1 = If (FCKSM0 = 1), then clock and PLL configurations are locked; if (FCKSM0 = 0), then clock and PLL configurations may be modified
- 0 = Clock and PLL selections are not locked, configurations may be modified

bit 6 **Unimplemented:** Read as '0'

bit 5 **LOCK:** PLL Lock Status bit (read-only)

- 1 = Indicates that PLL is in lock or PLL start-up timer is satisfied
- 0 = Indicates that PLL is out of lock, start-up timer is in progress or PLL is disabled

bit 4 **Unimplemented:** Read as '0'

**Note 1:** Writes to this register require an unlock sequence (see [Section 9.10 “OSCCON Unlock Sequence”](#)).

**Note 2:** Direct clock switches between any Primary Oscillator mode with PLL and FRCPLL mode are not permitted. This applies to clock switches in either direction. In these instances, the application must switch to FRC mode as a transitional clock source between the two PLL modes.

**Note 3:** This bit should only be cleared in software. Setting the bit in software (= 1) will have the same effect as an actual oscillator failure and will trigger an oscillator failure trap.

# dsPIC33CK256MP508 FAMILY

---

## REGISTER 9-1: OSCCON: OSCILLATOR CONTROL REGISTER<sup>(1)</sup> (CONTINUED)

- bit 3      **CF:** Clock Fail Detect bit<sup>(3)</sup>  
            1 = FSCM has detected a clock failure  
            0 = FSCM has not detected a clock failure
- bit 2-1    **Unimplemented:** Read as '0'
- bit 0      **OSWEN:** Oscillator Switch Enable bit  
            1 = Requests oscillator switch to the selection specified by the NOSC[2:0] bits  
            0 = Oscillator switch is complete

- Note 1:** Writes to this register require an unlock sequence (see [Section 9.10 “OSCCON Unlock Sequence”](#)).
- 2:** Direct clock switches between any Primary Oscillator mode with PLL and FRCPLL mode are not permitted. This applies to clock switches in either direction. In these instances, the application must switch to FRC mode as a transitional clock source between the two PLL modes.
- 3:** This bit should only be cleared in software. Setting the bit in software (= 1) will have the same effect as an actual oscillator failure and will trigger an oscillator failure trap.

# dsPIC33CK256MP508 FAMILY

## REGISTER 9-2: CLKDIV: CLOCK DIVIDER REGISTER

R/W-0	R/W-0	R/W-1	R/W-1	R/W-0	R/W-0	R/W-0	R/W-0
ROI	DOZE2 <sup>(1)</sup>	DOZE1 <sup>(1)</sup>	DOZE0 <sup>(1)</sup>	DOZEN <sup>(2,3)</sup>	FRCDIV2	FRCDIV1	FRCDIV0
bit 15						bit 8	

U-0	U-0	r-0	r-0	R/W-0	R/W-0	R/W-0	R/W-1
—	—	—	—	PLLPRE[3:0] <sup>(4)</sup>			
bit 7						bit 0	

<b>Legend:</b>	r = Reserved bit		
R = Readable bit	W = Writable bit	U = Unimplemented bit, read as '0'	
-n = Value at POR	'1' = Bit is set	'0' = Bit is cleared	x = Bit is unknown

- bit 15      **ROI:** Recover on Interrupt bit  
 1 = Interrupts will clear the DOZEN bit and the processor clock, and the peripheral clock ratio is set to 1:1  
 0 = Interrupts have no effect on the DOZEN bit
- bit 14-12    **DOZE[2:0]:** Processor Clock Reduction Select bits<sup>(1)</sup>  
 111 = FP divided by 128  
 110 = FP divided by 64  
 101 = FP divided by 32  
 100 = FP divided by 16  
 011 = FP divided by 8 (default)  
 010 = FP divided by 4  
 001 = FP divided by 2  
 000 = FP divided by 1
- bit 11      **DOZEN:** Doze Mode Enable bit<sup>(2,3)</sup>  
 1 = DOZE[2:0] field specifies the ratio between the peripheral clocks and the processor clocks  
 0 = Processor clock and peripheral clock ratio is forced to 1:1
- bit 10-8    **FRCDIV[2:0]:** Internal Fast RC Oscillator Postscaler bits  
 111 = FRC divided by 256  
 110 = FRC divided by 64  
 101 = FRC divided by 32  
 100 = FRC divided by 16  
 011 = FRC divided by 8  
 010 = FRC divided by 4  
 001 = FRC divided by 2  
 000 = FRC divided by 1 (default)
- bit 7-6     **Unimplemented:** Read as '0'
- bit 5-4     **Reserved:** Read as '0'

- Note 1:** The DOZE[2:0] bits can only be written to when the DOZEN bit is clear. If DOZEN = 1, any writes to DOZE[2:0] are ignored.
- 2:** This bit is cleared when the ROI bit is set and an interrupt occurs.
- 3:** The DOZEN bit cannot be set if DOZE[2:0] = 000. If DOZE[2:0] = 000, any attempt by user software to set the DOZEN bit is ignored.
- 4:** PLLPRE[3:0] may be updated while the PLL is operating, but the VCO may overshoot.

# dsPIC33CK256MP508 FAMILY

---

## REGISTER 9-2: CLKDIV: CLOCK DIVIDER REGISTER (CONTINUED)

bit 3-0      **PLLPRE[3:0]**: PLL Phase Detector Input Divider Select bits (also denoted as 'N1', PLL prescaler)<sup>(4)</sup>

- 11111 = Reserved
- ...
- 1001 = Reserved
- 1000 = Input divided by 8
- 0111 = Input divided by 7
- 0110 = Input divided by 6
- 0101 = Input divided by 5
- 0100 = Input divided by 4
- 0011 = Input divided by 3
- 0010 = Input divided by 2
- 0001 = Input divided by 1 (power-on default selection)
- 0000 = Reserved

- Note 1:** The DOZE[2:0] bits can only be written to when the DOZEN bit is clear. If DOZEN = 1, any writes to DOZE[2:0] are ignored.
- 2:** This bit is cleared when the ROI bit is set and an interrupt occurs.
- 3:** The DOZEN bit cannot be set if DOZE[2:0] = 000. If DOZE[2:0] = 000, any attempt by user software to set the DOZEN bit is ignored.
- 4:** PLLPRE[3:0] may be updated while the PLL is operating, but the VCO may overshoot.

# dsPIC33CK256MP508 FAMILY

## REGISTER 9-3: PLLFBD: PLL FEEDBACK DIVIDER REGISTER

U-0	U-0	U-0	U-0	r-0	r-0	r-0	r-0
—	—	—	—	—	—	—	—
bit 15							bit 8

R/W-1	R/W-0	R/W-0	R/W-1	R/W-0	R/W-1	R/W-1	R/W-0
PLLFBDIV[7:0]							
bit 7							bit 0

<b>Legend:</b>	r = Reserved bit		
R = Readable bit	W = Writable bit	U = Unimplemented bit, read as '0'	
-n = Value at POR	'1' = Bit is set	'0' = Bit is cleared	x = Bit is unknown

- bit 15-12     **Unimplemented:** Read as '0'
- bit 11-8     **Reserved:** Maintain as '0'
- bit 7-0      **PLLFBDIV[7:0]:** PLL Feedback Divider bits (also denoted as 'M', PLL multiplier)
  - 11111111 = Reserved
  - ...
  - 11001000 = 200 Maximum<sup>(1)</sup>
  - ...
  - 10010110 = 150 (default)
  - ...
  - 00010000 = 16 Minimum<sup>(1)</sup>
  - ...
  - 00000010 = Reserved
  - 00000001 = Reserved
  - 00000000 = Reserved

**Note 1:** The allowed range is 16-200 (decimal). The rest of the values are reserved and should be avoided. The power on the default feedback divider is 150 (decimal) with an 8 MHz FRC input clock. The VCO frequency is 1.2 GHz.



# dsPIC33CK256MP508 FAMILY

## REGISTER 9-4: OSCTUN: FRC OSCILLATOR TUNING REGISTER

U-0	U-0	U-0	U-0	U-0	U-0	U-0	U-0
—	—	—	—	—	—	—	—
bit 15							bit 8

U-0	U-0	R/W-0	R/W-0	R/W-0	R/W-0	R/W-0	R/W-0
—	—	TUN[5:0]					
bit 7							bit 0

### Legend:

R = Readable bit	W = Writable bit	U = Unimplemented bit, read as '0'
-n = Value at POR	'1' = Bit is set	'0' = Bit is cleared
		x = Bit is unknown

bit 15-6     **Unimplemented:** Read as '0'

bit 5-0     **TUN[5:0]:** FRC Oscillator Tuning bits

0111111 = Maximum frequency deviation of 1.45% (MHz)

0111110 = Center frequency + 1.40% (MHz)

...

0000001 = Center frequency + 0.047% (MHz)

0000000 = Center frequency (8.00 MHz nominal)

1111111 = Center frequency – 0.047% (MHz)

...

1000001 = Center frequency – 1.45% (MHz)

1000000 = Minimum frequency deviation of -1.50% (MHz)

# dsPIC33CK256MP508 FAMILY

## REGISTER 9-5: PLLDIV: PLL OUTPUT DIVIDER REGISTER

U-0	U-0	U-0	U-0	U-0	U-0	R/W-0	R/W-0
—	—	—	—	—	—	VCODIV[1:0]	
bit 15						bit 8	

U-0	R/W-1	R/W-0	R/W-0	U-0	R/W-0	R/W-0	R/W-1
—	POST1DIV[2:0] <sup>(1,2)</sup>			—	POST2DIV[2:0] <sup>(1,2)</sup>		
bit 7				bit 0			

### Legend:

R = Readable bit      W = Writable bit      U = Unimplemented bit, read as '0'  
 -n = Value at POR      '1' = Bit is set      '0' = Bit is cleared      x = Bit is unknown

bit 15-10      **Unimplemented:** Read as '0'

bit 9-8      **VCODIV[1:0]:** PLL VCO Output Divider Select bits

11 = FVCO  
 10 = FVCO/2  
 01 = FVCO/3  
 00 = FVCO/4

bit 7      **Unimplemented:** Read as '0'

bit 6-4      **POST1DIV[2:0]:** PLL Output Divider #1 Ratio bits<sup>(1,2)</sup>

POST1DIV[2:0] can have a valid value, from 1 to 7 (POST1DIVx value should be greater than or equal to the POST2DIVx value). The POST1DIVx divider is designed to operate at higher clock rates than the POST2DIVx divider.

bit 3      **Unimplemented:** Read as '0'

bit 2-0      **POST2DIV[2:0]:** PLL Output Divider #2 Ratio bits<sup>(1,2)</sup>

POST2DIV[2:0] can have a valid value, from 1 to 7 (POST2DIVx value should be less than or equal to the POST1DIVx value). The POST1DIVx divider is designed to operate at higher clock rates than the POST2DIVx divider.

**Note 1:** The POST1DIVx and POST2DIVx divider values must not be changed while the PLL is operating.

**Note 2:** The default values for POST1DIVx and POST2DIVx are 4 and 1, respectively, yielding a 150 MHz system source clock.

# dsPIC33CK256MP508 FAMILY

## REGISTER 9-6: ACLKCON1: AUXILIARY CLOCK CONTROL REGISTER

R/W-0	R/W-0	U-0	U-0	U-0	U-0	U-0	R/W-0
APLLEN <sup>(1)</sup>	APLLCK	—	—	—	—	—	FRCSEL
bit 15							bit 8

U-0	U-0	r-0	r-0	R/W-0	R/W-0	R/W-0	R/W-1
—	—	—	—	APLLPRE[3:0]			
bit 7							bit 0

<b>Legend:</b>	r = Reserved bit		
R = Readable bit	W = Writable bit	U = Unimplemented bit, read as '0'	
-n = Value at POR	'1' = Bit is set	'0' = Bit is cleared	x = Bit is unknown

- bit 15      **APLLEN:** Auxiliary PLL Enable/Bypass Select bit<sup>(1)</sup>  
 1 = AFPLLO is connected to the APLL post-divider output (bypass disabled)  
 0 = AFPLLO is connected to the APLL input clock (bypass enabled)
- bit 14      **APLLCK:** APLL Phase-Locked State Status bit  
 1 = Auxiliary PLL is in lock  
 0 = Auxiliary PLL is not in lock
- bit 13-9    **Unimplemented:** Read as '0'
- bit 8        **FRCSEL:** FRC Clock Source Select bit  
 1 = FRC is the clock source for APLL  
 0 = Primary Oscillator is the clock source for APLL
- bit 7-6     **Unimplemented:** Read as '0'
- bit 5-4     **Reserved:** Maintain as '0'
- bit 3-0     **APLLPRE[3:0]:** Auxiliary PLL Phase Detector Input Divider bits  
 1111 = Reserved  
 ...  
 1001 = Reserved  
 1000 = Input divided by 8  
 0111 = Input divided by 7  
 0110 = Input divided by 6  
 0101 = Input divided by 5  
 0100 = Input divided by 4  
 0011 = Input divided by 3  
 0010 = Input divided by 2  
 0001 = Input divided by 1 (power-on default selection)  
 0000 = Reserved

**Note 1:** Even with the APLLEN bit set, another peripheral must generate a clock request before the APLL will start.

# dsPIC33CK256MP508 FAMILY

## REGISTER 9-7: APLLFBDD1: APLL FEEDBACK DIVIDER REGISTER

U-0	U-0	U-0	U-0	r-0	r-0	r-0	r-0
—	—	—	—	—	—	—	—
bit 15							bit 8

R/W-1	R/W-0	R/W-0	R/W-1	R/W-0	R/W-1	R/W-1	R/W-0
APLLFBDDIV[7:0]							
bit 7							bit 0

<b>Legend:</b>	r = Reserved bit		
R = Readable bit	W = Writable bit	U = Unimplemented bit, read as '0'	
-n = Value at POR	'1' = Bit is set	'0' = Bit is cleared	x = Bit is unknown

- bit 15-12     **Unimplemented:** Read as '0'
- bit 11-8     **Reserved:** Maintain as '0'
- bit 7-0      **APLLFBDDIV[7:0]:** APLL Feedback Divider bits
  - 11111111 = Reserved
  - ...
  - 11001000 = 200 maximum<sup>(1)</sup>
  - ...
  - 10010110 = 150 (default)
  - ...
  - 00010000 = 16 minimum<sup>(1)</sup>
  - ...
  - 00000010 = Reserved
  - 00000001 = Reserved
  - 00000000 = Reserved

**Note 1:** The allowed range is 16-200 (decimal). The rest of the values are reserved and should be avoided. The power-on default feedback divider is 150 (decimal) with an 8 MHz FRC input clock; the VCO frequency is 1.2 GHz.

# dsPIC33CK256MP508 FAMILY

## REGISTER 9-8: APLL DIV1: APLL OUTPUT DIVIDER REGISTER

U-0	U-0	U-0	U-0	U-0	U-0	R/W-0	R/W-0
—	—	—	—	—	—	AVCODIV[1:0]	
bit 15						bit 8	

U-0	R/W-1	R/W-0	R/W-0	U-0	R/W-0	R/W-0	R/W-1
—	APOST1DIV[2:0] <sup>(1,2)</sup>			—	APOST2DIV[2:0] <sup>(1,2)</sup>		
bit 7				bit 0			

### Legend:

R = Readable bit

W = Writable bit

U = Unimplemented bit, read as '0'

-n = Value at POR

'1' = Bit is set

'0' = Bit is cleared

x = Bit is unknown

bit 15-10 **Unimplemented:** Read as '0'

bit 9-8 **AVCODIV[1:0]:** APLL VCO Output Divider Select bits

11 = AFVCO

10 = AFVCO/2

01 = AFVCO/3

00 = AFVCO/4

bit 7 **Unimplemented:** Read as '0'

bit 6-4 **APOST1DIV[2:0]:** APLL Output Divider #1 Ratio bits<sup>(1,2)</sup>

APOST1DIV[2:0] can have a valid value, from 1 to 7 (the APOST1DIVx value should be greater than or equal to the APOST2DIVx value). The APOST1DIVx divider is designed to operate at higher clock rates than the APOST2DIVx divider.

bit 3 **Unimplemented:** Read as '0'

bit 2-0 **APOST2DIV[2:0]:** APLL Output Divider #2 Ratio bits<sup>(1,2)</sup>

APOST2DIV[2:0] can have a valid value, from 1 to 7 (the APOST2DIVx value should be less than or equal to the APOST1DIVx value). The APOST1DIVx divider is designed to operate at higher clock rates than the APOST2DIVx divider.

**Note 1:** The APOST1DIVx and APOST2DIVx values must not be changed while the PLL is operating.

**Note 2:** The default values for APOST1DIVx and APOST2DIVx are 4 and 1, respectively, yielding a 150 MHz system source clock.

# dsPIC33CK256MP508 FAMILY

## REGISTER 9-9: CANCLKCON: CAN CLOCK CONTROL REGISTER

R/W-0	U-0	U-0	U-0	R/W-0	R/W-0	R/W-0	R/W-0
CANCLKEN	—	—	—	CANCLKSEL[3:0] <sup>(1)</sup>			
bit 15				bit 8			

U-0	R/W-0	R/W-0	R/W-0	R/W-0	R/W-0	R/W-0	R/W-0
—	CANCLKDIV[6:0] <sup>(2,3)</sup>						
bit 7							bit 0

### Legend:

R = Readable bit

W = Writable bit

U = Unimplemented bit, read as '0'

-n = Value at POR

'1' = Bit is set

'0' = Bit is cleared

x = Bit is unknown

bit 15 **CANCLKEN:** Enables the CAN Clock Generator bit

1 = CAN clock generation circuitry is enabled

0 = CAN clock generation circuitry is disabled

bit 14-12 **Unimplemented:** Read as '0'

bit 11-8 **CANCLKSEL[3:0]:** CAN Clock Source Select bits<sup>(1)</sup>

1011-1111 = Reserved (no clock selected)

1010 = AFVCO/4

1001 = AFVCO/3

1000 = AFVCO/2

0111 = AFVCO

0110 = AFPLLO

0101 = FVCO/4

0100 = FVCO/3

0011 = FVCO/2

0010 = FPLLO

0001 = FVCO

0000 = 0 (no clock selected)

bit 7 **Unimplemented:** Read as '0'

bit 6-0 **CANCLKDIV[6:0]:** CAN Clock Divider Select bits<sup>(2,3)</sup>

1111111 = Divide-by-128

...

0000010 = Divide-by-3

0000001 = Divide-by-2

0000000 = Divide-by-1

**Note 1:** The user must ensure the input clock source is 640 MHz or less. Operation with input reference frequency above 640 MHz will result in unpredictable behavior.

**2:** The CANCLKDIVx divider value must not be changed during CAN module operation.

**3:** The user must ensure the maximum clock output frequency of the divider is 80 MHz or less.

# dsPIC33CK256MP508 FAMILY

## REGISTER 9-10: REFOCONL: REFERENCE CLOCK CONTROL LOW REGISTER

R/W-0	U-0	R/W-0	R/W-0	R/W-0	U-0	HC/R/W-0	HSC/R-0
ROEN	—	ROSIDL	ROOUT	ROSLP	—	ROSWEN	ROACTIV
bit 15						bit 8	

U-0	U-0	U-0	U-0	R/W-0	R/W-0	R/W-0	R/W-0
—	—	—	—	ROSEL[3:0]			
bit 7						bit 0	

<b>Legend:</b>	HC = Hardware Clearable bit	HSC = Hardware Settable/Clearable bit
R = Readable bit	W = Writable bit	U = Unimplemented bit, read as '0'
-n = Value at POR	'1' = Bit is set	'0' = Bit is cleared
		x = Bit is unknown

- bit 15     **ROEN:** Reference Clock Enable bit  
1 = Reference Oscillator is enabled on the REFCLKO pin  
0 = Reference Oscillator is disabled
- bit 14     **Unimplemented:** Read as '0'
- bit 13     **ROSIDL:** Reference Clock Stop in Idle bit  
1 = Reference Oscillator is disabled in Idle mode  
0 = Reference Oscillator continues to run in Idle mode
- bit 12     **ROOUT:** Reference Clock Output Enable bit  
1 = Reference clock external output is enabled and available on the REFCLKO pin  
0 = Reference clock external output is disabled
- bit 11     **ROSLP:** Reference Clock Stop in Sleep bit  
1 = Reference Oscillator continues to run in Sleep modes  
0 = Reference Oscillator is disabled in Sleep modes
- bit 10     **Unimplemented:** Read as '0'
- bit 9       **ROSWEN:** Reference Clock Switch Request and Status bit  
1 = Clock divider change (requested by changes to RODIVx) is requested or is in progress (set in software, cleared by hardware upon completion)  
0 = Clock divider change has completed or is not pending
- bit 8       **ROACTIV:** Reference Clock Status bit  
1 = Reference clock is active; do not change clock source  
0 = Reference clock is stopped; clock source and configuration may be safely changed
- bit 7-4    **Unimplemented:** Read as '0'
- bit 3-0    **ROSEL[3:0]:** Reference Clock Source Select bits  
1111 = Reserved  
... = Reserved  
1000 = Reserved  
0111 = REFI pin  
0110 = FVCO/4  
0101 = BFRC  
0100 = LPRC  
0011 = FRC  
0010 = Primary Oscillator  
0001 = Peripheral clock (FP)  
0000 = System clock (FOSC)

# dsPIC33CK256MP508 FAMILY

## REGISTER 9-11: REFOCONH: REFERENCE CLOCK CONTROL HIGH REGISTER

U-0	R/W-0	R/W-0	R/W-0	R/W-0	R/W-0	R/W-0	R/W-0
—	RODIV[14:8]						
bit 15	bit 8						

R/W-0	R/W-0	R/W-0	R/W-0	R/W-0	R/W-0	R/W-0	R/W-0
RODIV[7:0]							
bit 7	bit 0						

### Legend:

R = Readable bit	W = Writable bit	U = Unimplemented bit, read as '0'
-n = Value at POR	'1' = Bit is set	'0' = Bit is cleared      x = Bit is unknown

bit 15      **Unimplemented:** Read as '0'

bit 14-0    **RODIV[14:0]:** Reference Clock Integer Divider Select bits

Divider for the selected input clock source is two times the selected value.

111 1111 1111 1111 = Base clock value divided by 65,534 (2 \* 7FFFh)

111 1111 1111 1110 = Base clock value divided by 65,532 (2 \* 7FFEh)

111 1111 1111 1101 = Base clock value divided by 65,530 (2 \* 7FFDh)

...

000 0000 0000 0010 = Base clock value divided by 4 (2 \* 2)

000 0000 0000 0001 = Base clock value divided by 2 (2 \* 1)

000 0000 0000 0000 = Base clock value



# dsPIC33CK256MP508 FAMILY

## REGISTER 9-12: REFOTRIMH: REFERENCE OSCILLATOR TRIM REGISTER

R/W-0	R/W-0	R/W-0	R/W-0	R/W-0	R/W-0	R/W-0	R/W-0
ROTRIM[8:1]							
bit 15							bit 8

R/W-0	U-0	U-0	U-0	U-0	U-0	U-0	U-0
ROTRIM0	—	—	—	—	—	—	—
bit 7							bit 0

<b>Legend:</b>			
R = Readable bit	W = Writable bit	U = Unimplemented bit, read as '0'	
-n = Value at POR	'1' = Bit is set	'0' = Bit is cleared	x = Bit is unknown

bit 15-7     **ROTRIM[8:0]:** REFO Trim bits

These bits provide a fractional additive to the RODIV[14:0] value for the 1/2 period of the REFO clock.

000000000 = 0/512 (0.0 divisor added to the RODIV[14:0] value)

000000001 = 1/512 (0.001953125 divisor added to the RODIV[14:0] value)

000000010 = 2/512 (0.00390625 divisor added to the RODIV[14:0] value)

...

100000000 = 256/512 (0.5000 divisor added to the RODIV[14:0] value)

...

111111110 = 510/512 (0.99609375 divisor added to the RODIV[14:0] value)

111111111 = 511/512 (0.998046875 divisor added to the RODIV[14:0] value)

bit 6-0     **Unimplemented:** Read as '0'

# dsPIC33CK256MP508 FAMILY

---

---

NOTES:

## 10.0 DIRECT MEMORY ACCESS (DMA) CONTROLLER

**Note 1:** This data sheet summarizes the features of this group of dsPIC33 devices. It is not intended to be a comprehensive reference source. For more information, refer to “**Direct Memory Access Controller (DMA)**” ([www.microchip.com/DS30009742](http://www.microchip.com/DS30009742)) in the “*dsPIC33/PIC24 Family Reference Manual*”.

The Direct Memory Access (DMA) Controller is designed to service high data throughput peripherals operating on the SFR bus, allowing them to access data memory directly and alleviating the need for CPU-intensive management. By allowing these data-intensive peripherals to share their own data path, the main data bus is also deloaded, resulting in additional power savings.

The DMA Controller functions both as a peripheral and a direct extension of the CPU. It is located on the microcontroller data bus, between the CPU and DMA-enabled peripherals, with direct access to SRAM. This partitions the SFR bus into two buses, allowing the DMA Controller access to the DMA-capable peripherals located on the new DMA SFR bus. The controller serves as an Initiator device on the DMA SFR bus, controlling data flow from DMA-capable peripherals.

The controller also monitors CPU instruction processing directly, allowing it to be aware of when the CPU requires access to peripherals on the DMA bus and automatically relinquishing control to the CPU as needed. This increases the effective bandwidth for handling data without DMA operations, causing a processor Stall. This makes the controller essentially transparent to the user.

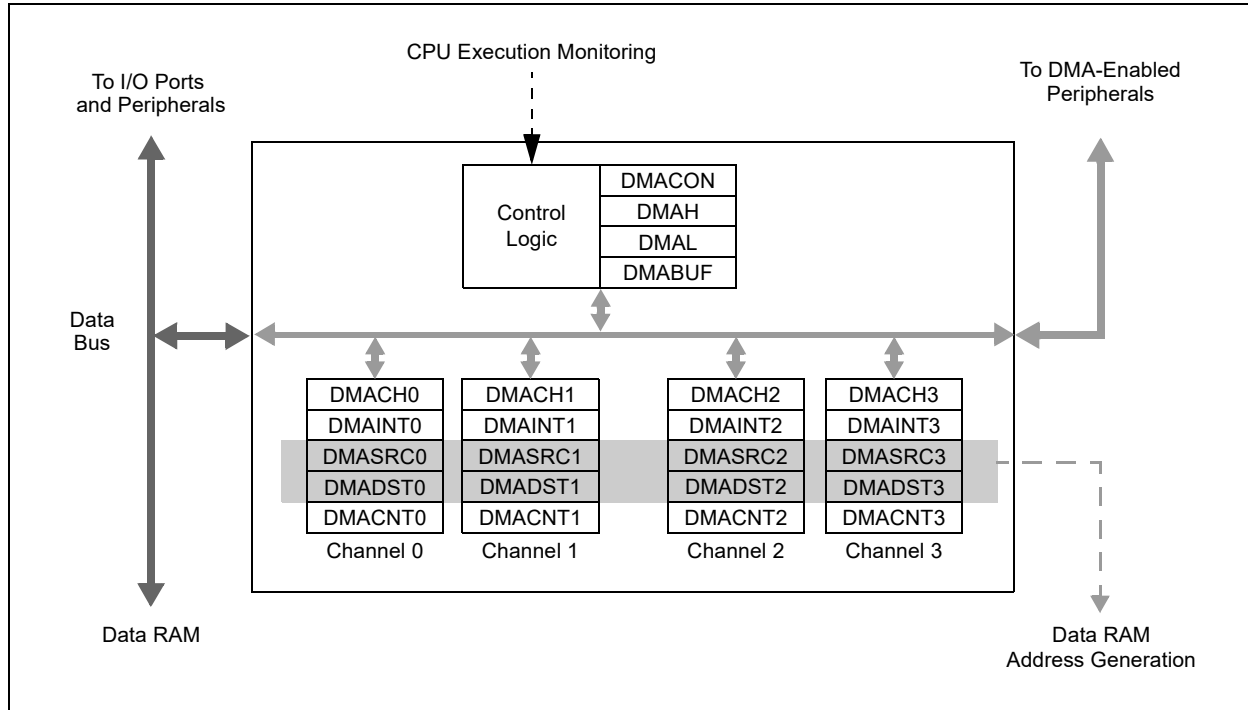
The DMA Controller has these features:

- Four Independently Programmable Channels
- Concurrent Operation with the CPU (no DMA caused Wait states)
- DMA Bus Arbitration
- Five Programmable Address modes
- Four Programmable Transfer modes
- Four Flexible Internal Data Transfer modes
- Byte or Word Support for Data Transfer
- 16-Bit Source and Destination Address Register for each Channel, Dynamically Updated and Reloadable
- 16-Bit Transaction Count Register, Dynamically Updated and Reloadable
- Upper and Lower Address Limit Registers
- Counter Half-Full Level Interrupt
- Software Triggered Transfer
- Null Write mode for Symmetric Buffer Operations

A simplified block diagram of the DMA Controller is shown in [Figure 10-1](#).

# dsPIC33CK256MP508 FAMILY

**FIGURE 10-1: DMA FUNCTIONAL BLOCK DIAGRAM**



## 10.1 Summary of DMA Operations

The DMA Controller is capable of moving data between addresses according to a number of different parameters. Each of these parameters can be independently configured for any transaction. In addition, any or all of the DMA channels can independently perform a different transaction at the same time. Transactions are classified by these parameters:

- Source and destination (SFRs and data RAM)
- Data size (byte or word)
- Trigger source
- Transfer mode (One-Shot, Repeated or Continuous)
- Addressing modes (Fixed Address or Address Blocks with or without Address Increment/Decrement)

In addition, the DMA Controller provides channel priority arbitration for all channels.

### 10.1.1 SOURCE AND DESTINATION

Using the DMA Controller, data may be moved between any two addresses in the Data Space. The SFR space (0000h to 0FFFh) or the data RAM space (1000h to 4FFFh) can serve as either the source or the destination. Data can be moved between these areas in either direction or between addresses in either area. The four different combinations are shown in [Figure 10-2](#).

If it is necessary to protect areas of data RAM, the DMA Controller allows the user to set upper and lower address boundaries for operations in the Data Space above the SFR space. The boundaries are set by the DMAH and DMAL Limit registers. If a DMA channel attempts an operation outside of the address boundaries, the transaction is terminated and an interrupt is generated.

### 10.1.2 DATA SIZE

The DMA Controller can handle both 8-bit and 16-bit transactions. Size is user-selectable using the SIZE bit (DMACHn[1]). By default, each channel is configured for word-size transactions. When byte-size transactions are chosen, the LSB of the source and/or destination address determines if the data represent the upper or lower byte of the data RAM location.

### 10.1.3 TRIGGER SOURCE

The DMA Controller can use 82 of the device's interrupt sources to initiate a transaction. The DMA trigger sources occur in reverse order from their natural interrupt priority and are shown in [Table 10-1](#).

Since the source and destination addresses for any transaction can be programmed independently of the trigger source, the DMA Controller can use any trigger to perform an operation on any peripheral. This also allows DMA channels to be cascaded to perform more complex transfer operations.

### 10.1.4 TRANSFER MODE

The DMA Controller supports four types of data transfers, based on the volume of data to be moved for each trigger.

- One-Shot: A single transaction occurs for each trigger.
- Continuous: A series of back-to-back transactions occur for each trigger; the number of transactions is determined by the DMACNTn transaction counter.
- Repeated One-Shot: A single transaction is performed repeatedly, once per trigger, until the DMA channel is disabled.
- Repeated Continuous: A series of transactions are performed repeatedly, one cycle per trigger, until the DMA channel is disabled.

All transfer modes allow the option to have the source and destination addresses, and counter value, automatically reloaded after the completion of a transaction.

### 10.1.5 ADDRESSING MODES

The DMA Controller also supports transfers between single addresses or address ranges. The four basic options are:

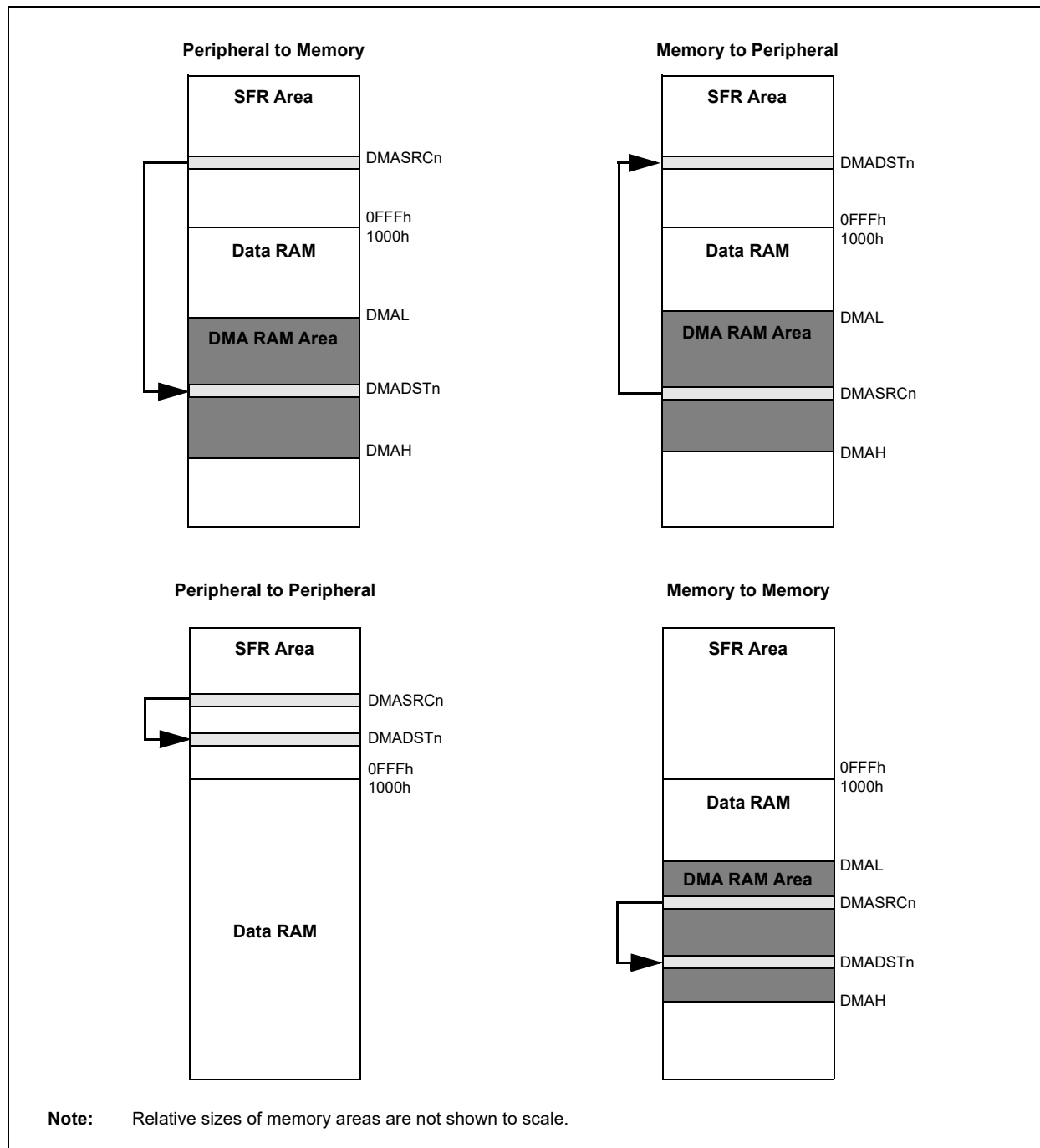
- Fixed-to-Fixed: Between two constant addresses
- Fixed-to-Block: From a constant source address to a range of destination addresses
- Block-to-Fixed: From a range of source addresses to a single, constant destination address
- Block-to-Block: From a range of source addresses to a range of destination addresses

The option to select auto-increment or auto-decrement of source and/or destination addresses is available for Block Addressing modes.

In addition to the four basic modes, the DMA Controller also supports Peripheral Indirect Addressing (PIA) mode, where the source or destination address is generated jointly by the DMA Controller and a PIA-capable peripheral. When enabled, the DMA channel provides a base source and/or destination address, while the peripheral provides a fixed range offset address.

# dsPIC33CK256MP508 FAMILY

FIGURE 10-2: TYPES OF DMA DATA TRANSFERS



## 10.1.6 CHANNEL PRIORITY

Each DMA channel functions independently of the others, but also competes with the others for access to the data and DMA buses. When access collisions occur, the DMA Controller arbitrates between the channels using a user-selectable priority scheme. Two schemes are available:

- Round Robin: When two or more channels collide, the lower numbered channel receives priority on the first collision. On subsequent collisions, the higher numbered channels each receive priority based on their channel number.
- Fixed: When two or more channels collide, the lowest numbered channel always receives priority, regardless of past history; however, any channel being actively processed is not available for an immediate retrigger. If a higher priority channel is continually requesting service, it will be scheduled for service after the next lower priority channel with a pending request.

## 10.2 Typical Setup

To set up a DMA channel for a basic data transfer:

1. Enable the DMA Controller (DMAEN = 1) and select an appropriate channel priority scheme by setting or clearing PRSSEL.
2. Program DMAH and DMAL with appropriate upper and lower address boundaries for data RAM operations.
3. Select the DMA channel to be used and disable its operation (CHEN = 0).
4. Program the appropriate source and destination addresses for the transaction into the channel's DMASRCn and DMADSTn registers. For PIA mode addressing, use the base address value.
5. Program the DMACNTn register for the number of triggers per transfer (One-Shot or Continuous modes) or the number of words (bytes) to be transferred (Repeated modes).
6. Set or clear the SIZE bit to select the data size.
7. Program the TRMODE[1:0] bits to select the Data Transfer mode.
8. Program the SAMODE[1:0] and DAMODE[1:0] bits to select the addressing mode.
9. Enable the DMA channel by setting CHEN.
10. Enable the trigger source interrupt.

## 10.3 Peripheral Module Disable

The channels of the DMA Controller can be individually powered down using the Peripheral Module Disable (PMD) registers.

## 10.4 Registers

The DMA Controller uses a number of registers to control its operation. The number of registers depends on the number of channels implemented for a particular device.

There are always four module-level registers (one control and three buffer/address):

- DMACON: DMA Engine Control Register ([Register 10-1](#))
- DMAH and DMAL: DMA High and Low Address Limit Registers
- DMABUF: DMA Transfer Data Buffer

Each of the DMA channels implements five registers (two control and three buffer/address):

- DMACHn: DMA Channel n Control Register ([Register 10-2](#))
- DMAINTn: DMA Channel n Interrupt Register ([Register 10-3](#))
- DMASRCn: DMA Data Source Address for Channel n Register
- DMADSTn: DMA Data Destination Address for Channel n Register
- DMACNTn: DMA Transaction Counter for Channel n Register

For dsPIC33CK256MP508 devices, there are a total of 34 registers.

# dsPIC33CK256MP508 FAMILY

## REGISTER 10-1: DMACON: DMA ENGINE CONTROL REGISTER

R/W-0	U-0	U-0	U-0	U-0	U-0	U-0	U-0
DMAEN	—	—	—	—	—	—	—
bit 15							bit 8

U-0	U-0	U-0	U-0	U-0	U-0	U-0	R/W-0
—	—	—	—	—	—	—	PRSEL
bit 7							bit 0

### Legend:

R = Readable bit                      W = Writable bit                      U = Unimplemented bit, read as '0'  
 -n = Value at POR                      '1' = Bit is set                      '0' = Bit is cleared                      x = Bit is unknown

- bit 15            **DMAEN:** DMA Module Enable bit
  - 1 = Enables module
  - 0 = Disables module and terminates all active DMA operation(s)
- bit 14-1       **Unimplemented:** Read as '0'
- bit 0            **PRSEL:** Channel Priority Scheme Selection bit
  - 1 = Round robin scheme
  - 0 = Fixed priority scheme



# dsPIC33CK256MP508 FAMILY

## REGISTER 10-2: DMACHn: DMA CHANNEL n CONTROL REGISTER

U-0	U-0	U-0	r-0	U-0	R/W-0	R/W-0	R/W-0
—	—	—	—	—	NULLW	RELOAD <sup>(1)</sup>	CHREQ <sup>(3)</sup>
bit 15						bit 8	

R/W-0	R/W-0	R/W-0	R/W-0	R/W-0	R/W-0	R/W-0	R/W-0
SAMODE1	SAMODE0	DAMODE1	DAMODE0	TRMODE1	TRMODE0	SIZE	CHEN
bit 7						bit 0	

<b>Legend:</b>	r = Reserved bit	U = Unimplemented bit, read as '0'
R = Readable bit	W = Writable bit	'0' = Bit is cleared
-n = Value at POR	'1' = Bit is set	x = Bit is unknown

- bit 15-13 **Unimplemented:** Read as '0'
- bit 12 **Reserved:** Maintain as '0'
- bit 11 **Unimplemented:** Read as '0'
- bit 10 **NULLW:** Null Write Mode bit  
1 = A dummy write is initiated to DMASRCn for every write to DMADSTn  
0 = No dummy write is initiated
- bit 9 **RELOAD:** Address and Count Reload bit<sup>(1)</sup>  
1 = DMASRCn, DMADSTn and DMACNTn registers are reloaded to their previous values upon the start of the next operation  
0 = DMASRCn, DMADSTn and DMACNTn are not reloaded on the start of the next operation<sup>(2)</sup>
- bit 8 **CHREQ:** DMA Channel Software Request bit<sup>(3)</sup>  
1 = A DMA request is initiated by software; automatically cleared upon completion of a DMA transfer  
0 = No DMA request is pending
- bit 7-6 **SAMODE[1:0]:** Source Address Mode Selection bits  
11 = DMASRCn is used in Peripheral Indirect Addressing and remains unchanged  
10 = DMASRCn is decremented based on the SIZE bit after a transfer completion  
01 = DMASRCn is incremented based on the SIZE bit after a transfer completion  
00 = DMASRCn remains unchanged after a transfer completion
- bit 5-4 **DAMODE[1:0]:** Destination Address Mode Selection bits  
11 = DMADSTn is used in Peripheral Indirect Addressing and remains unchanged  
10 = DMADSTn is decremented based on the SIZE bit after a transfer completion  
01 = DMADSTn is incremented based on the SIZE bit after a transfer completion  
00 = DMADSTn remains unchanged after a transfer completion
- bit 3-2 **TRMODE[1:0]:** Transfer Mode Selection bits  
11 = Repeated Continuous  
10 = Continuous  
01 = Repeated One-Shot  
00 = One-Shot
- bit 1 **SIZE:** Data Size Selection bit  
1 = Byte (8-bit)  
0 = Word (16-bit)
- bit 0 **CHEN:** DMA Channel Enable bit  
1 = The corresponding channel is enabled  
0 = The corresponding channel is disabled

- Note 1:** Only the original DMACNTn is required to be stored to recover the original DMASRCn and DMADSTn values.
- 2:** DMACNTn will always be reloaded in Repeated mode transfers, regardless of the state of the RELOAD bit.
- 3:** The number of transfers executed while CHREQ is set depends on the configuration of TRMODE[1:0].

# dsPIC33CK256MP508 FAMILY

## REGISTER 10-3: DMAINTn: DMA CHANNEL n INTERRUPT REGISTER

R-0	R/W-0	R/W-0	R/W-0	R/W-0	R/W-0	R/W-0	R/W-0
DBUFWF <sup>(1)</sup>	CHSEL6	CHSEL5	CHSEL4	CHSEL3	CHSEL2	CHSEL1	CHSEL0
bit 15							bit 8

R/W-0	R/W-0	R/W-0	R/W-0	R/W-0	U-0	U-0	R/W-0
HIGHIF <sup>(1,2)</sup>	LOWIF <sup>(1,2)</sup>	DONEIF <sup>(1)</sup>	HALFIF <sup>(1)</sup>	OVRUNIF <sup>(1)</sup>	—	—	HALFEN
bit 7							bit 0

### Legend:

R = Readable bit                      W = Writable bit                      U = Unimplemented bit, read as '0'  
 -n = Value at POR                      '1' = Bit is set                      '0' = Bit is cleared                      x = Bit is unknown

- bit 15            **DBUFWF:** DMA Buffered Data Write Flag bit<sup>(1)</sup>  
 1 = The content of the DMA buffer has not been written to the location specified in DMADSTn or DMASRCn in Null Write mode  
 0 = The content of the DMA buffer has been written to the location specified in DMADSTn or DMASRCn in Null Write mode
- bit 14-8        **CHSEL[6:0]:** DMA Channel Trigger Selection bits  
 See [Table 10-1](#) for a complete list.
- bit 7            **HIGHIF:** DMA High Address Limit Interrupt Flag bit<sup>(1,2)</sup>  
 1 = The DMA channel has attempted to access an address higher than DMAH or the upper limit of the data RAM space  
 0 = The DMA channel has not invoked the high address limit interrupt
- bit 6            **LOWIF:** DMA Low Address Limit Interrupt Flag bit<sup>(1,2)</sup>  
 1 = The DMA channel has attempted to access the DMA SFR address lower than DMAL, but above the SFR range (07FFh)  
 0 = The DMA channel has not invoked the low address limit interrupt
- bit 5            **DONEIF:** DMA Complete Operation Interrupt Flag bit<sup>(1)</sup>  
If CHEN = 1:  
 1 = The previous DMA session has ended with completion  
 0 = The current DMA session has not yet completed  
If CHEN = 0:  
 1 = The previous DMA session has ended with completion  
 0 = The previous DMA session has ended without completion
- bit 4            **HALFIF:** DMA 50% Watermark Level Interrupt Flag bit<sup>(1)</sup>  
 1 = DMACNTn has reached the halfway point to 0000h  
 0 = DMACNTn has not reached the halfway point
- bit 3            **OVRUNIF:** DMA Channel Overrun Flag bit<sup>(1)</sup>  
 1 = The DMA channel is triggered while it is still completing the operation based on the previous trigger  
 0 = The overrun condition has not occurred
- bit 2-1        **Unimplemented:** Read as '0'
- bit 0            **HALFEN:** Halfway Completion Watermark bit  
 1 = Interrupts are invoked when DMACNTn has reached its halfway point and at completion  
 0 = An interrupt is invoked only at the completion of the transfer

- Note 1:** Setting these flags in software does not generate an interrupt.  
**Note 2:** Testing for address limit violations (DMASRCn or DMADSTn is either greater than DMAH or less than DMAL) is NOT done before the actual access.

# dsPIC33CK256MP508 FAMILY

**TABLE 10-1: DMA CHANNEL TRIGGER SOURCES**

CHSEL[6:0]	Trigger (Interrupt)	CHSEL[6:0]	Trigger (Interrupt)	CHSEL[6:0]	Trigger (Interrupt)
00h	INT0 – External Interrupt 0	23h	PWM Generator 8	44h	CLC1 Positive Edge Interrupt
01h	SCCP1 Interrupt	24h	PWM Event C	45h	CLC2 Positive Edge Interrupt
02h	SPI1 Receiver	25h	SENT1 TX/RX	46h	SPI1 – Fault Interrupt
03h	SPI1 Transmitter	26h	SENT2 TX/RX	47h	SPI2 – Fault Interrupt
04h	UART1 Receiver	27h	ADC1 Group Convert Done	48h	(Reserved, do not use)
05h	UART1 Transmitter	28h	ADC Done AN0	...	
06h	ECC Single-Bit Error	29h	ADC Done AN1	56h	
07h	NVM Write Complete	2Ah	ADC Done AN2	57h	PWM Event D
08h	INT1 – External Interrupt 1	2Bh	ADC Done AN3	58h	PWM Event E
09h	SI2C1 – I2C1 Client Event	2Ch	ADC Done AN4	59h	PWM Event F
0Ah	MI2C1 – I2C1 Host Event	2Dh	ADC Done AN5	5Ah	(Reserved, do not use)
0Bh	INT2 – External Interrupt 2	2Eh	ADC Done AN6	5Bh	(Reserved, do not use)
0Ch	SCCP2 Interrupt	2Fh	ADC Done AN7	5Ch	SCCP7 Interrupt
0Dh	INT3 – External Interrupt 3	30h	ADC Done AN8	5Dh	SCCP8 Interrupt
0Eh	UART2 Receiver	31h	ADC Done AN9	5Eh	(Reserved, do not use)
0Fh	UART2 Transmitter	32h	ADC Done AN10	5Fh	(Reserved, do not use)
10h	SPI2 Receiver	33h	ADC Done AN11	60h	CLC3 Positive Edge Interrupt
11h	SPI2 Transmitter	34h	ADC Done AN12	61h	CLC4 Positive Edge Interrupt
12h	SCCP3 Interrupt	35h	ADC Done AN13	62h	SPI3 Receiver
13h	SI2C2 – I2C2 Client Event	36h	ADC Done AN14	63h	SPI3 Transmitter
14h	MI2C2 – I2C1 Host Event	37h	ADC Done AN15	64h	SI2C3 – I2C3 Client Event
15h	SCCP4 Interrupt	38h	ADC Done AN16	65h	MI2C3 – I2C3 Host Event
16h	SCCP5 Interrupt	39h	ADC Done AN17	66h	SPI3 Fault
17h	SCCP6 Interrupt	3Ah	ADC Done AN18	67h	MCCP9
18h	CRC Generator Interrupt	3Bh	ADC Done AN19	68h	UART3 Receiver
19h	PWM Event A	3Ch	ADC Done AN20	69h	UART3 Transmitter
1Ah	(Reserved, do not use)	3Dh	ADC Done AN21	6Ah	ADC Done AN24
1Bh	PWM Event B	3Eh	ADC Done AN22	6Bh	ADC Done AN25
1Ch	PWM Generator 1	3Fh	ADC Done AN23	6Ch	PMP Event
1Dh	PWM Generator 2	40h	AD1FLTR1 – Oversample Filter 1	6Dh	PMP Error Event
1Eh	PWM Generator 3	41h	AD1FLTR2 – Oversample Filter 2	6Eh	(Reserved, do not use)
1Fh	PWM Generator 4	42h	AD1FLTR3 – Oversample Filter 3	...	
20h	PWM Generator 5	43h	AD1FLTR4 – Oversample Filter 4	7Fh	
21h	PWM Generator 6				
22h	PWM Generator 7				

# dsPIC33CK256MP508 FAMILY

---

NOTES:

## 11.0 CONTROLLER AREA NETWORK (CAN FD) MODULE

**Note 1:** This data sheet summarizes the features of the dsPIC33CK256MP508 family of devices. It is not intended to be a comprehensive reference source. For more information, refer to “CAN Flexible Data-Rate (FD) Protocol Module” ([www.microchip.com/DS70005340](http://www.microchip.com/DS70005340)) in the “dsPIC33/PIC24 Family Reference Manual”.

**2:** Not all device variants include the CAN FD peripheral. Refer to [Table 1](#) and [Table 2](#) for availability.

### 11.1 Features

The CAN FD module has the following features:

#### General

- Nominal (Arbitration) Bit Rate up to 1 Mbps
- Data Bit Rate up to 8 Mbps
- CAN FD Controller modes:
  - Mixed CAN 2.0B and CAN FD mode
  - CAN 2.0B mode
- Conforms to ISO 11898-1:2015

#### Message FIFOs

- Seven FIFOs, Configurable as Transmit or Receive FIFOs
- One Transmit Queue (TXQ)
- Transmit Event FIFO (TEF) with 32-Bit Timestamp

#### Message Transmission

- Message Transmission Prioritization:
  - Based on priority bit field, and/or
  - Message with lowest ID gets transmitted first using the TXQ
- Programmable Automatic Retransmission Attempts: Unlimited, Three Attempts or Disabled

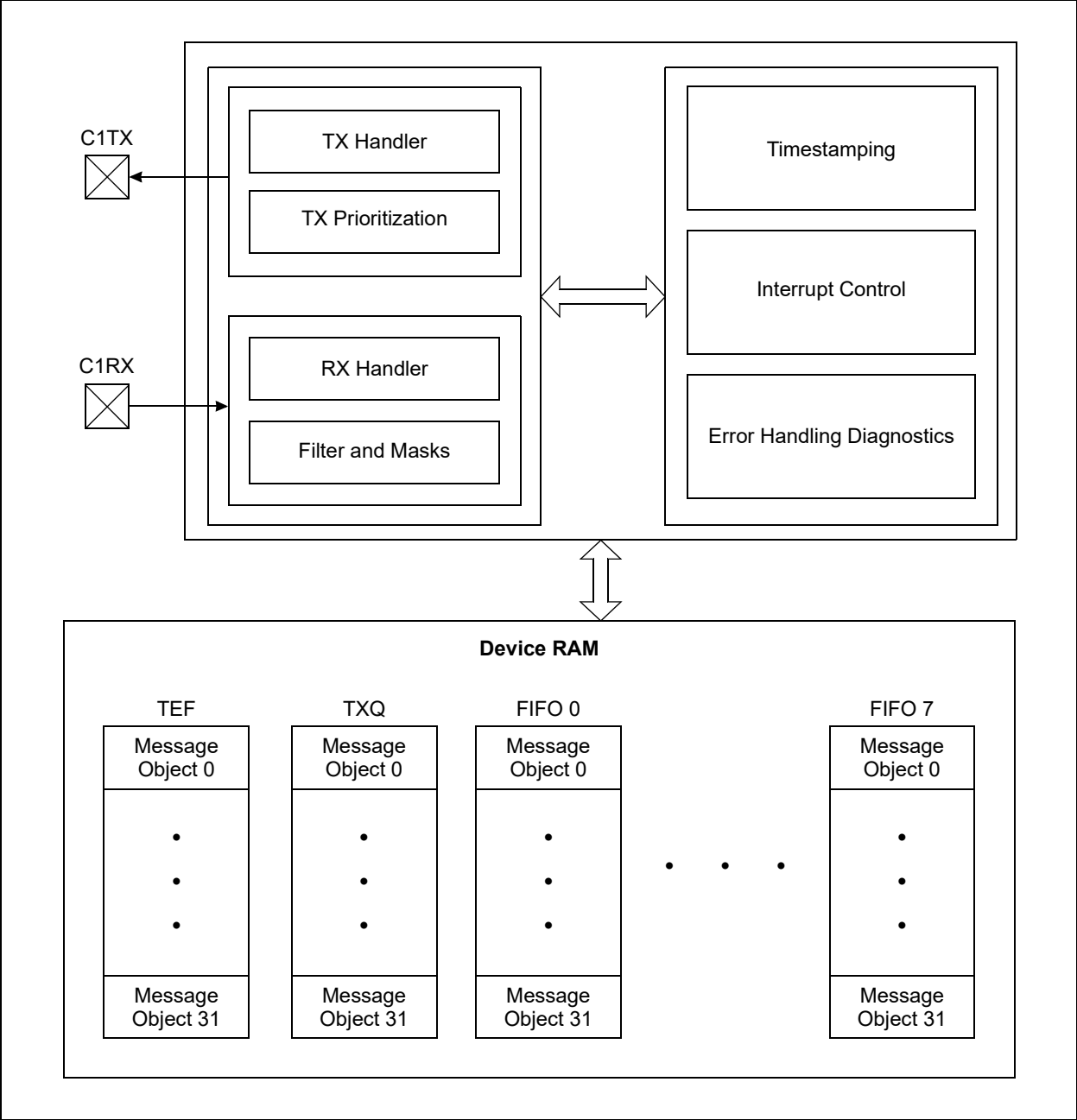
#### Message Reception

- 16 Flexible Filter and Mask Objects.
- Each Object can be Configured to Filter either:
  - Standard ID + first 18 data bits or
  - Extended ID
- 32-Bit Timestamp.
- The CAN FD Bit Stream Processor (BSP) Implements the Medium Access Control of the CAN FD Protocol Described in ISO 11898-1:2015. It serializes and deserializes the bit stream, encodes and decodes the CAN FD frames, manages the medium access, Acknowledges frames, and detects and signals errors.
- The TX Handler Prioritizes the Messages that are Requested for Transmission by the Transmit FIFOs. It uses the RAM interface to fetch the transmit data from RAM and provides them to the BSP for transmission.
- The BSP provides Received Messages to the RX Handler. The RX handler uses acceptance filters to filter out messages that shall be stored in the Receive FIFOs. It uses the RAM interface to store received data into RAM.
- Each FIFO can be Configured either as a Transmit or Receive FIFO. The FIFO control keeps track of the FIFO head and tail, and calculates the user address. In a TX FIFO, the user address points to the address in RAM where the data for the next transmit message shall be stored. In an RX FIFO, the user address points to the address in RAM where the data of the next receive message shall be read. The user notifies the FIFO that a message was written to or read from RAM by incrementing the head/tail of the FIFO.
- The Transmit Queue (TXQ) is a Special Transmit FIFO that Transmits the Messages based on the ID of the Messages Stored in the Queue.
- The Transmit Event FIFO (TEF) Stores the Message IDs of the Transmitted Messages.
- A Free-Running Time Base Counter is used to Timestamp Received Messages. Messages in the TEF can also be timestamped.
- The CAN FD Controller module Generates Interrupts when New Messages are Received or when Messages were Transmitted Successfully.

[Figure 11-1](#) shows the CAN FD system block diagram.

# dsPIC33CK256MP508 FAMILY

FIGURE 11-1: CAN FD MODULE BLOCK DIAGRAM



# dsPIC33CK256MP508 FAMILY

## 11.2 Can Control Registers

### REGISTER 11-1: C1CONH: CAN CONTROL REGISTER HIGH

R/W-0	R/W-0	R/W-0	R/W-0	S/HC-0	R/W-1	R/W-0	R/W-0
TXBWS3	TXBWS2	TXBWS1	TXBWS0	ABAT	REQOP2	REQOP1	REQOP0
bit 15							bit 8

R-1	R-0	R-0	R/W-1	R/W-1	R/W-0	R/W-0	R/W-0
OPMOD2	OPMOD1	OPMOD0	TXQEN <sup>(1)</sup>	STEF <sup>(1)</sup>	SERRLOM <sup>(1)</sup>	ESIGM <sup>(1)</sup>	RTXAT <sup>(1)</sup>
bit 7							bit 0

<b>Legend:</b>	S = Settable bit	HC = Hardware Clearable bit
R = Readable bit	W = Writable bit	U = Unimplemented bit, read as '0'
-n = Value at POR	'1' = Bit is set	'0' = Bit is cleared
		x = Bit is unknown

bit 15-12 **TXBWS[3:0]:** Transmit Bandwidth Sharing bits

1111-1100 = 4096  
 1011 = 2048  
 1010 = 1024  
 1001 = 512  
 1000 = 256  
 0111 = 128  
 0110 = 64  
 0101 = 32  
 0100 = 16  
 0011 = 8  
 0010 = 4  
 0001 = 2  
 0000 = No delay

bit 11 **ABAT:** Abort All Pending Transmissions bit

1 = Signals all transmit buffers to abort transmission  
 0 = Module will clear this bit when all transmissions are aborted

bit 10-8 **REQOP[2:0]:** Request Operation Mode bits

111 = Sets Restricted Operation mode  
 110 = Sets Normal CAN 2.0 mode; error frames on CAN FD frames  
 101 = Sets External Loopback mode  
 100 = Sets Configuration mode  
 011 = Sets Listen Only mode  
 010 = Sets Internal Loopback mode  
 001 = Sets Disable mode  
 000 = Sets Normal CAN FD mode; supports mixing of full CAN FD and classic CAN 2.0 frames

bit 7-5 **OPMOD[2:0]:** Operation Mode Status bits

111 = Module is in Restricted Operation mode  
 110 = Module is in Normal CAN 2.0 mode; error frames on CAN FD frames  
 101 = Module is in External Loopback mode  
 100 = Module is in Configuration mode  
 011 = Module is in Listen Only mode  
 010 = Module is in Internal Loopback mode  
 001 = Module is in Disable mode  
 000 = Module is in Normal CAN FD mode; supports mixing of full CAN FD and classic CAN 2.0 frames

**Note 1:** These bits can only be modified in Configuration mode (OPMOD[2:0] = 100).

# dsPIC33CK256MP508 FAMILY

---

## REGISTER 11-1: C1CONH: CAN CONTROL REGISTER HIGH (CONTINUED)

- bit 4      **TXQEN:** Enable Transmit Queue bit<sup>(1)</sup>  
1 = Enables Transmit Message Queue (TXQ) and reserves space in RAM  
0 = Does not reserve space in RAM for TXQ
- bit 3      **STEF:** Store in Transmit Event FIFO bit<sup>(1)</sup>  
1 = Saves transmitted messages in TEF  
0 = Does not save transmitted messages in TEF
- bit 2      **SERRLOM:** Transition to Listen Only Mode on System Error bit<sup>(1)</sup>  
1 = Transitions to Listen Only mode  
0 = Transitions to Restricted Operation mode
- bit 1      **ESIGM:** Transmit ESI in Gateway Mode bit<sup>(1)</sup>  
1 = ESI is transmitted as recessive when ESI of the message is high or CAN controller is error passive  
0 = ESI reflects error status of CAN controller
- bit 0      **RTXAT:** Restrict Retransmission Attempts bit<sup>(1)</sup>  
1 = Restricted retransmission attempts, uses TXAT[1:0] bits (C1TXQCONH[6:5])  
0 = Unlimited number of retransmission attempts, TXAT[1:0] bits will be ignored

**Note 1:** These bits can only be modified in Configuration mode (OPMOD[2:0] = 100).



# dsPIC33CK256MP508 FAMILY

## REGISTER 11-2: C1CONL: CAN CONTROL REGISTER LOW

R/W-0	U-0	R/W-0	R/W-0	R/W-0	R/W-1	R/W-1	R/W-1
CON	—	SIDL	BRSDIS	BUSY	WFT1	WFT0	WAKFIL <sup>(1)</sup>
bit 15						bit 8	

R/W-0	R/W-1	R/W-1	R/W-0	R/W-0	R/W-0	R/W-0	R/W-0
CLKSEL <sup>(1)</sup>	PXEDIS <sup>(1)</sup>	ISOCRCEN <sup>(1)</sup>	DNCNT4	DNCNT3	DNCNT2	DNCNT1	DNCNT0
bit 7						bit 0	

### Legend:

R = Readable bit	W = Writable bit	U = Unimplemented bit, read as '0'
-n = Value at POR	'1' = Bit is set	'0' = Bit is cleared
		x = Bit is unknown

bit 15	<b>CON:</b> CAN Enable bit 1 = CAN module is enabled 0 = CAN module is disabled
bit 14	<b>Unimplemented:</b> Read as '0'
bit 13	<b>SIDL:</b> CAN Stop in Idle Control bit 1 = Stops module operation in Idle mode 0 = Does not stop module operation in Idle mode
bit 12	<b>BRSDIS:</b> Bit Rate Switching (BRS) Disable bit 1 = Bit Rate Switching is disabled, regardless of BRS in the transmit message object 0 = Bit Rate Switching depends on BRS in the transmit message object
bit 11	<b>BUSY:</b> CAN Module is Busy bit 1 = The CAN module is active 0 = The CAN module is inactive
bit 10-9	<b>WFT[1:0]:</b> Selectable Wake-up Filter Time bits 11 = T11FILTER 10 = T10FILTER 01 = T01FILTER 00 = T00FILTER
bit 8	<b>WAKFIL:</b> Enable CAN Bus Line Wake-up Filter bit <sup>(1)</sup> 1 = Uses CAN bus line filter for wake-up 0 = CAN bus line filter is not used for wake-up
bit 7	<b>CLKSEL:</b> Module Clock Source Select bit <sup>(1)</sup> 1 = Auxiliary clock is active when module is enabled 0 = CAN clock is not active when module is enabled
bit 6	<b>PXEDIS:</b> Protocol Exception Event Detection Disabled bit <sup>(1)</sup> A recessive "reserved bit" following a recessive FDF bit is called a Protocol Exception. 1 = Protocol Exception is treated as a form error 0 = If a Protocol Exception is detected, CAN will enter the bus integrating state
bit 5	<b>ISOCRCEN:</b> Enable ISO CRC in CAN FD Frames bit <sup>(1)</sup> 1 = Includes stuff bit count in CRC field and uses non-zero CRC initialization vector 0 = Does not include stuff bit count in CRC field and uses CRC initialization vector with all zeros
bit 4-0	<b>DNCNT[4:0]:</b> DeviceNet™ Filter Bit Number bits 10011–11111 = Invalid selection (compares up to 18 bits of data with EID) 10010 = Compares up to Data Byte 2, bit 6 with EID17 ... 00001 = Compares up to Data Byte 0, bit 7 with EID0 00000 = Does not compare data bytes

**Note 1:** These bits can only be modified in Configuration mode (OPMOD[2:0] = 100).

# dsPIC33CK256MP508 FAMILY

## REGISTER 11-3: C1NBTCFGH: CAN NOMINAL BIT TIME CONFIGURATION REGISTER HIGH<sup>(1)</sup>

R/W-0	R/W-0	R/W-0	R/W-0	R/W-0	R/W-0	R/W-0	R/W-0
BRP[7:0]							
bit 15				bit 8			

R/W-0	R/W-0	R/W-1	R/W-1	R/W-1	R/W-1	R/W-0	R/W-0
TSEG1[7:0]							
bit 7				bit 0			

### Legend:

R = Readable bit                      W = Writable bit                      U = Unimplemented bit, read as '0'  
 -n = Value at POR                      '1' = Bit is set                      '0' = Bit is cleared                      x = Bit is unknown

bit 15-8                      **BRP[7:0]:** Baud Rate Prescaler bits

1111 1111 =  $T_q = 256/F_{sys}$

...

0000 0000 =  $T_q = 1/F_{sys}$

bit 7-0                      **TSEG1[7:0]:** Time Segment 1 bits (Propagation Segment + Phase Segment 1)

1111 1111 = Length is  $256 \times T_q$

...

0000 0000 = Length is  $1 \times T_q$

**Note 1:** These bits can only be modified in Configuration mode (OPMOD[2:0] = 100).

## REGISTER 11-4: C1NBTCFGL: CAN NOMINAL BIT TIME CONFIGURATION REGISTER LOW<sup>(1)</sup>

U-0	R/W-0	R/W-0	R/W-0	R/W-1	R/W-1	R/W-1	R/W-1
—	TSEG2[6:0]						
bit 15				bit 8			

U-0	R/W-0	R/W-0	R/W-0	R/W-1	R/W-1	R/W-1	R/W-1
—	SJW[6:0]						
bit 7				bit 0			

### Legend:

R = Readable bit                      W = Writable bit                      U = Unimplemented bit, read as '0'  
 -n = Value at POR                      '1' = Bit is set                      '0' = Bit is cleared                      x = Bit is unknown

bit 15                      **Unimplemented:** Read as '0'

bit 14-8                      **TSEG2[6:0]:** Time Segment 2 bits (Phase Segment 2)

111 1111 = Length is  $128 \times T_q$

...

000 0000 = Length is  $1 \times T_q$

bit 7                      **Unimplemented:** Read as '0'

bit 6-0                      **SJW[6:0]:** Synchronization Jump Width bits

111 1111 = Length is  $128 \times T_q$

...

000 0000 = Length is  $1 \times T_q$

**Note 1:** These bits can only be modified in Configuration mode (OPMOD[2:0] = 100).

# dsPIC33CK256MP508 FAMILY

## REGISTER 11-5: C1DBTCFGH: CAN DATA BIT TIME CONFIGURATION REGISTER HIGH<sup>(1)</sup>

R/W-0	R/W-0	R/W-0	R/W-0	R/W-0	R/W-0	R/W-0	R/W-0	
BRP[7:0]								
bit 15								bit 8
U-0	U-0	U-0	R/W-0	R/W-1	R/W-1	R/W-1	R/W-0	
—	—	—	TSEG1[4:0]					
bit 7								bit 0

### Legend:

R = Readable bit                      W = Writable bit                      U = Unimplemented bit, read as '0'  
 -n = Value at POR                      '1' = Bit is set                      '0' = Bit is cleared                      x = Bit is unknown

- bit 15-8        **BRP[7:0]:** Baud Rate Prescaler bits  
                   1111 1111 =  $T_Q = 256/F_{SYS}$   
                   ...  
                   0000 0000 =  $T_Q = 1/F_{SYS}$
- bit 7-5        **Unimplemented:** Read as '0'
- bit 4-0        **TSEG1[4:0]:** Time Segment 1 bits (Propagation Segment + Phase Segment 1)  
                   1 1111 = Length is 32 x  $T_Q$   
                   ...  
                   0 0000 = Length is 1 x  $T_Q$

**Note 1:** This register can only be modified in Configuration mode (OPMOD[2:0] = 100).

## REGISTER 11-6: C1DBTCFGL: CAN DATA BIT TIME CONFIGURATION REGISTER LOW<sup>(1)</sup>

U-0	U-0	U-0	U-0	R/W-0	R/W-0	R/W-1	R/W-1	
—	—	—	—	TSEG2[3:0]				
bit 15								bit 8
U-0	U-0	U-0	U-0	R/W-0	R/W-0	R/W-1	R/W-1	
—	—	—	—	SJW[3:0]				
bit 7								bit 0

### Legend:

R = Readable bit                      W = Writable bit                      U = Unimplemented bit, read as '0'  
 -n = Value at POR                      '1' = Bit is set                      '0' = Bit is cleared                      x = Bit is unknown

- bit 15-12      **Unimplemented:** Read as '0'
- bit 11-8        **TSEG2[3:0]:** Time Segment 2 bits (Phase Segment 2)  
                   1111 = Length is 16 x  $T_Q$   
                   ...  
                   0000 = Length is 1 x  $T_Q$
- bit 7-4        **Unimplemented:** Read as '0'
- bit 3-0        **SJW[3:0]:** Synchronization Jump Width bits  
                   1111 = Length is 16 x  $T_Q$   
                   ...  
                   0000 = Length is 1 x  $T_Q$

**Note 1:** This register can only be modified in Configuration mode (OPMOD[2:0] = 100).

# dsPIC33CK256MP508 FAMILY

## REGISTER 11-7: C1TDCH: CAN TRANSMITTER DELAY COMPENSATION REGISTER HIGH<sup>(1)</sup>

U-0	U-0	U-0	U-0	U-0	U-0	R/W-0	R/W-0
—	—	—	—	—	—	EDGFLTEN	SID11EN
bit 15						bit 8	

U-0	U-0	U-0	U-0	U-0	U-0	R/W-1	R/W-0
—	—	—	—	—	—	TDCMOD[1:0]	
bit 7						bit 0	

### Legend:

R = Readable bit                      W = Writable bit                      U = Unimplemented bit, read as '0'  
 -n = Value at POR                      '1' = Bit is set                      '0' = Bit is cleared                      x = Bit is unknown

- bit 15-10      **Unimplemented:** Read as '0'
- bit 9          **EDGFLTEN:** Enable Edge Filtering During Bus Integration State bit  
                   1 = Edge filtering is enabled according to ISO 11898-1:2015  
                   0 = Edge filtering is disabled
- bit 8          **SID11EN:** Enable 12-Bit SID in CAN FD Base Format Messages bit  
                   1 = RRS is used as SID11 in CAN FD base format messages: SID[11:0] = {SID[10:0], SID11}  
                   0 = Does not use RRS; SID[10:0]
- bit 7-2       **Unimplemented:** Read as '0'
- bit 1-0       **TDCMOD[1:0]:** Transmitter Delay Compensation Mode bits (Secondary Sample Point (SSP))  
                   10-11 = Auto: Measures delay and adds TDCO[6:0]  
                   01 = Manual: Does not measure, uses TDCV[5:0] + TDCO[6:0] from register  
                   00 = Disable

**Note 1:** This register can only be modified in Configuration mode (OPMOD[2:0] = 100).

# dsPIC33CK256MP508 FAMILY

## REGISTER 11-8: C1TDCL: CAN TRANSMITTER DELAY COMPENSATION REGISTER LOW<sup>(1,2)</sup>

U-0	R/W-0	R/W-0	R/W-1	R/W-0	R/W-0	R/W-0	R/W-0
—	TDCO[6:0]						
bit 15	bit 8						

U-0	U-0	R/W-0	R/W-0	R/W-0	R/W-0	R/W-0	R/W-0
—	—	TDCV[5:0]					
bit 7	bit 0						

### Legend:

R = Readable bit

W = Writable bit

U = Unimplemented bit, read as '0'

-n = Value at POR

'1' = Bit is set

'0' = Bit is cleared

x = Bit is unknown

bit 15 **Unimplemented:** Read as '0'

bit 14-8 **TDCO[6:0]:** Transmitter Delay Compensation Offset bits (Secondary Sample Point (SSP))

111 1111 = -64 x TCAN

...

011 1111 = 63 x TCAN

...

000 0000 = 0 x TCAN

bit 7-6 **Unimplemented:** Read as '0'

bit 5-0 **TDCV[5:0]:** Transmitter Delay Compensation Value bits (Secondary Sample Point (SSP))

11 1111 = 63 x TCAN

...

00 0000 = 0 x TCAN

**Note 1:** This register can only be modified in Configuration mode (OPMOD[2:0] = 100).

**Note 2:** TCAN = 1/FCAN. FCAN is the clock which comes out of the CAN clock generator.

# dsPIC33CK256MP508 FAMILY

## REGISTER 11-9: C1TBCH: CAN TIME BASE COUNTER REGISTER HIGH<sup>(1,2)</sup>

R/W-0	R/W-0	R/W-0	R/W-0	R/W-0	R/W-0	R/W-0	R/W-0
TBC[31:24]							
bit 15				bit 8			

R/W-0	R/W-0	R/W-0	R/W-0	R/W-0	R/W-0	R/W-0	R/W-0
TBC[23:16]							
bit 7				bit 0			

**Legend:**

R = Readable bit                      W = Writable bit                      U = Unimplemented bit, read as '0'  
 -n = Value at POR                      '1' = Bit is set                      '0' = Bit is cleared                      x = Bit is unknown

bit 15-0                      **TBC[31:16]** CAN Time Base Counter bits  
 This is a free-running timer that increments every TBCPREx clock when TBCEN is set.

- Note 1:** The Time Base Counter (TBC) will be stopped and reset when TBCEN = 0 to save power.  
**Note 2:** The TBC prescaler count will be reset on any write to C1TBCH/L (TBCPREx will be unaffected).

## REGISTER 11-10: C1TBCL: CAN TIME BASE COUNTER REGISTER LOW<sup>(1,2)</sup>

R/W-0	R/W-0	R/W-0	R/W-0	R/W-0	R/W-0	R/W-0	R/W-0
TBC[15:8]							
bit 15				bit 8			

R/W-0	R/W-0	R/W-0	R/W-0	R/W-0	R/W-0	R/W-0	R/W-0
TBC[7:0]							
bit 7				bit 0			

**Legend:**

R = Readable bit                      W = Writable bit                      U = Unimplemented bit, read as '0'  
 -n = Value at POR                      '1' = Bit is set                      '0' = Bit is cleared                      x = Bit is unknown

bit 15-0                      **TBC[15:0]** CAN Time Base Counter bits  
 This is a free-running timer that increments every TBCPREx clock when TBCEN is set.

- Note 1:** The TBC will be stopped and reset when TBCEN = 0 to save power.  
**Note 2:** The TBC prescaler count will be reset on any write to C1TBCH/L (TBCPREx will be unaffected).

# dsPIC33CK256MP508 FAMILY

## REGISTER 11-11: C1TSCONH: CAN TIMESTAMP CONTROL REGISTER HIGH

U-0	U-0	U-0	U-0	U-0	U-0	U-0	U-0
—	—	—	—	—	—	—	—
bit 15						bit 8	

U-0	U-0	U-0	U-0	U-0	R/W-0	R/W-0	R/W-0
—	—	—	—	—	TSRES	TSEOF	TBCEN
bit 7						bit 0	

### Legend:

R = Readable bit                      W = Writable bit                      U = Unimplemented bit, read as '0'  
 -n = Value at POR                      '1' = Bit is set                      '0' = Bit is cleared                      x = Bit is unknown

- bit 15-3      **Unimplemented:** Read as '0'
- bit 2      **TSRES:** Timestamp Reset bit (CAN FD frames only)
  - 1 = At sample point of the bit following the FDF bit
  - 0 = At sample point of Start-of-Frame (SOF)
- bit 1      **TSEOF:** Timestamp End-of-Frame (EOF) bit
  - 1 = Timestamp when frame is taken valid (11898-1 10.7):
    - RX no error until last, but one bit of EOF
    - TX no error until the end of EOF
  - 0 = Timestamp at "beginning" of frame:
    - Classical Frame: At sample point of SOF
    - FD Frame: See TSRES bit
- bit 0      **TBCEN:** Time Base Counter Enable bit
  - 1 = Enables TBC
  - 0 = Stops and resets TBC

## REGISTER 11-12: C1TSCONL: CAN TIMESTAMP CONTROL REGISTER LOW

U-0	U-0	U-0	U-0	U-0	U-0	R/W-0	R/W-0
—	—	—	—	—	—	TBCPRE[9:8]	
bit 15						bit 8	

R/W-0	R/W-0	R/W-0	R/W-0	R/W-0	R/W-0	R/W-0	R/W-0
TBCPRE[7:0]							
bit 7						bit 0	

### Legend:

R = Readable bit                      W = Writable bit                      U = Unimplemented bit, read as '0'  
 -n = Value at POR                      '1' = Bit is set                      '0' = Bit is cleared                      x = Bit is unknown

- bit 15-10      **Unimplemented:** Read as '0'
- bit 9-0      **TBCPRE[9:0]:** CAN Time Base Counter Prescaler bits
  - 1023 = TBC increments every 1024 clocks
  - ...
  - 0 = TBC increments every 1 clock

# dsPIC33CK256MP508 FAMILY

## REGISTER 11-13: C1VECH: CAN INTERRUPT CODE REGISTER HIGH

U-0	R-1	R-0	R-0	R-0	R-0	R-0	R-0	
—	RXCODE[6:0]							
bit 15								bit 8

U-0	R-1	R-0	R-0	R-0	R-0	R-0	R-0	
—	TXCODE[6:0]							
bit 7								bit 0

### Legend:

R = Readable bit	W = Writable bit	U = Unimplemented bit, read as '0'
-n = Value at POR	'1' = Bit is set	'0' = Bit is cleared
		x = Bit is unknown

bit 15      **Unimplemented:** Read as '0'

bit 14-8    **RXCODE[6:0]:** Receive Interrupt Flag Code bits  
 1000001-1111111 = Reserved  
 1000000 = No interrupt  
 0001000-0111111 = Reserved  
 0000111 = FIFO 7 interrupt (RFIF7 is set)  
 ...  
 0000010 = FIFO 2 interrupt (RFIF2 is set)  
 0000001 = FIFO 1 interrupt (RFIF1 is set)  
 0000000 = Reserved; FIFO 0 cannot receive

bit 7      **Unimplemented:** Read as '0'

bit 6-0    **TXCODE[6:0]:** Transmit Interrupt Flag Code bits  
 1000001-1111111 = Reserved  
 1000000 = No interrupt  
 0001000-0111111 = Reserved  
 0000111 = FIFO 7 interrupt (TFIF7 is set)  
 ...  
 0000001 = FIFO 1 interrupt (TFIF1 is set)  
 0000000 = FIFO 0 interrupt (TFIF0 is set)



# dsPIC33CK256MP508 FAMILY

## REGISTER 11-14: C1VECL: CAN INTERRUPT CODE REGISTER LOW

U-0	U-0	U-0	R-0	R-0	R-0	R-0	R-0
—	—	—	FILHIT[4:0]				
bit 15							bit 8

U-0	R-1	R-0	R-0	R-0	R-0	R-0	R-0
—	ICODE[6:0]						
bit 7							bit 0

### Legend:

R = Readable bit                      W = Writable bit                      U = Unimplemented bit, read as '0'  
 -n = Value at POR                      '1' = Bit is set                      '0' = Bit is cleared                      x = Bit is unknown

bit 15-13      **Unimplemented:** Read as '0'

bit 12-8      **FILHIT[4:0]:** Filter Hit Number bits

01111 = Filter 15  
 01110 = Filter 14  
 ...  
 00001 = Filter 1  
 00000 = Filter 0

bit 7      **Unimplemented:** Read as '0'

bit 6-0      **ICODE[6:0]:** Interrupt Flag Code bits

1001011-1111111 = Reserved  
 1001010 = Transmit attempt interrupt (any bit in C1TXATIF is set)  
 1001001 = Transmit event FIFO interrupt (any bit in C1TEFSTA is set)  
 1001000 = Invalid message occurred (IVMIF/IE)  
 1000111 = CAN module mode change occurred (MODIF/IE)  
 1000110 = CAN timer overflow (TBCIF/IE)  
 1000101 = RX/TX MAB overflow/underflow (RX: Message received before previous message was saved to memory; TX: Can't feed TX MAB fast enough to transmit consistent data)  
 1000100 = Address error interrupt (illegal FIFO address presented to system)  
 1000011 = Receive FIFO overflow interrupt (any bit in C1RXOVIF is set)  
 1000010 = Wake-up interrupt (WAKIF/WAKIE)  
 1000001 = Error interrupt (CERRIF/IE)  
 1000000 = No interrupt  
 0001000-0111111 = Reserved  
 0000111 = FIFO 7 interrupt (TFIF7 or RFIF7 is set)  
 ...  
 0000001 = FIFO 1 interrupt (TFIF1 or RFIF1 is set)  
 0000000 = FIFO 0 interrupt (TFIF0 is set)

# dsPIC33CK256MP508 FAMILY

## REGISTER 11-15: C1INTH: CAN INTERRUPT REGISTER HIGH

R/W-0	R/W-0	R/W-0	R/W-0	R/W-0	R/W-0	U-0	U-0
IVMIE	WAKIE	CERRIE	SERRIE	RXOVIE	TXATIE	—	—
bit 15						bit 8	

U-0	U-0	U-0	R/W-0	R/W-0	R/W-0	R/W-0	R/W-0
—	—	—	TEFIE	MODIE	TBCIE	RXIE	TXIE
bit 7						bit 0	

### Legend:

R = Readable bit                      W = Writable bit                      U = Unimplemented bit, read as '0'  
 -n = Value at POR                      '1' = Bit is set                      '0' = Bit is cleared                      x = Bit is unknown

- bit 15            **IVMIE:** Invalid Message Interrupt Enable bit  
                   1 = Invalid message interrupt is enabled  
                   0 = Invalid message interrupt is disabled
- bit 14            **WAKIE:** Bus Wake-up Activity Interrupt Enable bit  
                   1 = Wake-up activity interrupt is enabled  
                   0 = Wake-up Activity Interrupt is disabled
- bit 13            **CERRIE:** CAN Bus Error Interrupt Enable bit  
                   1 = CAN bus error interrupt is enabled  
                   0 = CAN bus error interrupt is disabled
- bit 12            **SERRIE:** System Error Interrupt Enable bit  
                   1 = System error interrupt is enabled  
                   0 = System error interrupt is disabled
- bit 11            **RXOVIE:** Receive Buffer Overflow Interrupt Enable bit  
                   1 = Receive buffer overflow interrupt is enabled  
                   0 = Receive buffer overflow interrupt is disabled
- bit 10            **TXATIE:** Transmit Attempt Interrupt Enable bit  
                   1 = Transmit attempt interrupt is enabled  
                   0 = Transmit attempt interrupt is disabled
- bit 9-5           **Unimplemented:** Read as '0'
- bit 4            **TEFIE:** Transmit Event FIFO Interrupt Enable bit  
                   1 = Transmit event FIFO interrupt is enabled  
                   0 = Transmit event FIFO interrupt is disabled
- bit 3            **MODIE:** Mode Change Interrupt Enable bit  
                   1 = Mode change interrupt is enabled  
                   0 = Mode change interrupt is disabled
- bit 2            **TBCIE:** CAN Timer Interrupt Enable bit  
                   1 = CAN timer interrupt is enabled  
                   0 = CAN timer interrupt is disabled
- bit 1            **RXIE:** Receive Object Interrupt Enable bit  
                   1 = Receive object interrupt is enabled  
                   0 = Receive object interrupt is disabled
- bit 0            **TXIE:** Transmit Object Interrupt Enable bit  
                   1 = Transmit object interrupt is enabled  
                   0 = Transmit object interrupt is disabled

# dsPIC33CK256MP508 FAMILY

## REGISTER 11-16: C1INTL: CAN INTERRUPT REGISTER LOW

HS/C-0	HS/C-0	HS/C-0	HS/C-0	R-0	R-0	U-0	U-0
IVMIF <sup>(1)</sup>	WAKIF <sup>(1)</sup>	CERRIF <sup>(1)</sup>	SERRIF <sup>(1)</sup>	RXOVIF	TXATIF	—	—
bit 15						bit 8	

U-0	U-0	U-0	R-0	HS/C-0	HS/C-0	R-0	R-0
—	—	—	TEFIF	MODIF <sup>(1)</sup>	TBCIF <sup>(1)</sup>	RXIF	TXIF
bit 7						bit 0	

<b>Legend:</b>	C = Clearable bit	HS = Hardware Settable bit
R = Readable bit	W = Writable bit	U = Unimplemented bit, read as '0'
-n = Value at POR	'1' = Bit is set	'0' = Bit is cleared
		x = Bit is unknown

- bit 15      **IVMIF:** Invalid Message Interrupt Flag bit<sup>(1)</sup>  
1 = Invalid message interrupt occurred  
0 = No invalid message interrupt occurred
- bit 14      **WAKIF:** Bus Wake-up Activity Interrupt Flag bit<sup>(1)</sup>  
1 = Wake-up activity interrupt occurred  
0 = No wake-up activity interrupt occurred
- bit 13      **CERRIF:** CAN Bus Error Interrupt Flag bit<sup>(1)</sup>  
1 = CAN bus error interrupt occurred  
0 = No CAN bus error interrupt occurred
- bit 12      **SERRIF:** System Error Interrupt Flag bit<sup>(1)</sup>  
1 = System error interrupt occurred  
0 = No system error interrupt occurred
- bit 11      **RXOVIF:** Receive Buffer Overflow Interrupt Flag bit  
1 = Receive buffer overflow interrupt occurred  
0 = No receive buffer overflow interrupt occurred
- bit 10      **TXATIF:** Transmit Attempt Interrupt Flag bit  
1 = Transmit attempt interrupt occurred  
0 = No transmit attempt Interrupt occurred
- bit 9-5      **Unimplemented:** Read as '0'
- bit 4      **TEFIF:** Transmit Event FIFO Interrupt Flag bit  
1 = Transmit event FIFO interrupt occurred  
0 = No transmit event FIFO interrupt occurred
- bit 3      **MODIF:** CAN Mode Change Interrupt Flag bit<sup>(1)</sup>  
1 = CAN module mode change occurred (OPMOD[2:0] have changed to reflect REQOP[2:0])  
0 = No mode change occurred
- bit 2      **TBCIF:** CAN Timer Overflow Interrupt Flag bit<sup>(1)</sup>  
1 = TBC has overflowed  
0 = TBC has not overflowed
- bit 1      **RXIF:** Receive Object Interrupt Flag bit  
1 = Receive object interrupt is pending  
0 = No receive object interrupts are pending
- bit 0      **TXIF:** Transmit Object Interrupt Flag bit  
1 = Transmit object interrupt is pending  
0 = No transmit object interrupts are pending

**Note 1:** C1INTL: Flags are set by hardware and cleared by application.

# dsPIC33CK256MP508 FAMILY

## REGISTER 11-17: C1RXIFH: CAN RECEIVE INTERRUPT STATUS REGISTER HIGH<sup>(1)</sup>

R-0	R-0	R-0	R-0	R-0	R-0	R-0	R-0
RFIF[31:24]							
bit 15				bit 8			

R-0	R-0	R-0	R-0	R-0	R-0	R-0	R-0
RFIF[23:16]							
bit 7				bit 0			

### Legend:

R = Readable bit                      W = Writable bit                      U = Unimplemented bit, read as '0'  
 -n = Value at POR                      '1' = Bit is set                      '0' = Bit is cleared                      x = Bit is unknown

bit 15-0                      **RFIF[31:16]:** Unimplemented

**Note 1:** C1RXIFH: FIFO: RFIFx = 'or' of enabled RX FIFO flags (flags need to be cleared in the FIFO register).

## REGISTER 11-18: C1RXIFL: CAN RECEIVE INTERRUPT STATUS REGISTER LOW<sup>(1)</sup>

R-0	R-0	R-0	R-0	R-0	R-0	R-0	R-0
RFIF[15:8]							
bit 15				bit 8			

R-0	R-0	R-0	R-0	R-0	R-0	R-0	U-0
RFIF[7:1]							—
bit 7				bit 0			

### Legend:

R = Readable bit                      W = Writable bit                      U = Unimplemented bit, read as '0'  
 -n = Value at POR                      '1' = Bit is set                      '0' = Bit is cleared                      x = Bit is unknown

bit 15-8                      **RFIF[15:8]:** Unimplemented

bit 7-1                      **RFIF[7:1]:** Receive FIFO Interrupt Pending bits  
                                     1 = One or more enabled receive FIFO interrupts are pending  
                                     0 = No enabled receive FIFO interrupts are pending

bit 0                      **Unimplemented:** Read as '0'

**Note 1:** C1RXIFL: FIFO: RFIFx = 'or' of enabled RX FIFO flags (flags need to be cleared in the FIFO register).

# dsPIC33CK256MP508 FAMILY

## REGISTER 11-19: C1RXOVIFH: CAN RECEIVE OVERFLOW INTERRUPT STATUS REGISTER HIGH<sup>(1)</sup>

R-0	R-0	R-0	R-0	R-0	R-0	R-0	R-0
RFOVIF[31:24]							
bit 15							
bit 8							

R-0	R-0	R-0	R-0	R-0	R-0	R-0	R-0
RFOVIF[23:16]							
bit 7							
bit 0							

### Legend:

R = Readable bit                      W = Writable bit                      U = Unimplemented bit, read as '0'  
 -n = Value at POR                      '1' = Bit is set                      '0' = Bit is cleared                      x = Bit is unknown

bit 15-0                      **RFOVIF[31:16]:** Unimplemented

**Note 1:** C1RXOVIFH: FIFO: RFOVIFx (flag needs to be cleared in the FIFO register).

## REGISTER 11-20: C1RXOVIFL: CAN RECEIVE OVERFLOW INTERRUPT STATUS REGISTER LOW<sup>(1)</sup>

R-0	R-0	R-0	R-0	R-0	R-0	R-0	R-0
RFOVIF[15:8]							
bit 15							
bit 8							

R-0	R-0	R-0	R-0	R-0	R-0	R-0	U-0
RFOVIF[7:1]							—
bit 7							
bit 0							

### Legend:

R = Readable bit                      W = Writable bit                      U = Unimplemented bit, read as '0'  
 -n = Value at POR                      '1' = Bit is set                      '0' = Bit is cleared                      x = Bit is unknown

bit 15-8                      **RFOVIF[15:8]:** Unimplemented

bit 7-1                      **RFOVIF[7:1]:** Receive FIFO Overflow Interrupt Pending bits

1 = Interrupt is pending  
 0 = Interrupt is not pending

bit 0                      **Unimplemented:** Read as '0'

**Note 1:** C1RXOVIFL: FIFO: RFOVIFx (flag needs to be cleared in the FIFO register).

# dsPIC33CK256MP508 FAMILY

## REGISTER 11-21: C1TXIFH: CAN TRANSMIT INTERRUPT STATUS REGISTER HIGH<sup>(1)</sup>

R-0	R-0	R-0	R-0	R-0	R-0	R-0	R-0
TFIF[31:24]							
bit 15							bit 8

R-0	R-0	R-0	R-0	R-0	R-0	R-0	R-0
TFIF[23:16]							
bit 7							bit 0

### Legend:

R = Readable bit                      W = Writable bit                      U = Unimplemented bit, read as '0'  
-n = Value at POR                      '1' = Bit is set                      '0' = Bit is cleared                      x = Bit is unknown

bit 15-0            **TFIF[31:16]:** Unimplemented

**Note 1:** C1TXIFH: FIFO: TFIFx = 'or' of the enabled TX FIFO flags (flags need to be cleared in the FIFO register).

## REGISTER 11-22: C1TXIFL: CAN TRANSMIT INTERRUPT STATUS REGISTER LOW<sup>(1)</sup>

R-0	R-0	R-0	R-0	R-0	R-0	R-0	R-0
TFIF[15:8]							
bit 15							bit 8

R-0	R-0	R-0	R-0	R-0	R-0	R-0	R-0
TFIF[7:0] <sup>(2)</sup>							
bit 7							bit 0

### Legend:

R = Readable bit                      W = Writable bit                      U = Unimplemented bit, read as '0'  
-n = Value at POR                      '1' = Bit is set                      '0' = Bit is cleared                      x = Bit is unknown

bit 15-8            **TFIF[15:8]:** Unimplemented

bit 7-0            **TFIF[7:0]:** Transmit FIFO/TXQ Interrupt Pending bits<sup>(2)</sup>

1 = One or more enabled transmit FIFO/TXQ interrupts are pending  
0 = No enabled transmit FIFO/TXQ interrupts are pending

**Note 1:** C1TXIFL: FIFO: TFIFx = 'or' of the enabled TX FIFO flags (flags need to be cleared in the FIFO register).

**2:** TFIF0 is for the transmit queue.

# dsPIC33CK256MP508 FAMILY

## REGISTER 11-23: C1TXATIFH: CAN TRANSMIT ATTEMPT INTERRUPT STATUS REGISTER HIGH<sup>(1)</sup>

R-0	R-0	R-0	R-0	R-0	R-0	R-0	R-0
TFATIF[31:24]							
bit 15				bit 8			

R-0	R-0	R-0	R-0	R-0	R-0	R-0	R-0
TFATIF[23:16]							
bit 7				bit 0			

### Legend:

R = Readable bit

W = Writable bit

U = Unimplemented bit, read as '0'

-n = Value at POR

'1' = Bit is set

'0' = Bit is cleared

x = Bit is unknown

bit 15-0      **TFATIF[31:16]:** Unimplemented

**Note 1:** C1TXATIFH: FIFO: TFATIFx (flag needs to be cleared in the FIFO register).

## REGISTER 11-24: C1TXATIFL: CAN TRANSMIT ATTEMPT INTERRUPT STATUS REGISTER LOW<sup>(1)</sup>

R-0	R-0	R-0	R-0	R-0	R-0	R-0	R-0
TFATIF[15:8]							
bit 15				bit 8			

R-0	R-0	R-0	R-0	R-0	R-0	R-0	R-0
TFATIF[7:0] <sup>(2)</sup>							
bit 7				bit 0			

### Legend:

R = Readable bit

W = Writable bit

U = Unimplemented bit, read as '0'

-n = Value at POR

'1' = Bit is set

'0' = Bit is cleared

x = Bit is unknown

bit 15-8      **TFATIF[15:8]:** Unimplemented

bit 7-0      **TFATIF[7:0]:** Transmit FIFO/TXQ Attempt Interrupt Pending bits<sup>(2)</sup>

1 = Interrupt is pending

0 = Interrupt is not pending

**Note 1:** C1TXATIFL: FIFO: TFATIFx (flag needs to be cleared in the FIFO register).

**2:** TFATIF0 is for the transmit queue.

# dsPIC33CK256MP508 FAMILY

## REGISTER 11-25: C1TXREQH: CAN TRANSMIT REQUEST REGISTER HIGH

S/HC-0	S/HC-0	S/HC-0	S/HC-0	S/HC-0	S/HC-0	S/HC-0	S/HC-0
TXREQ[31:24]							
bit 15				bit 8			

S/HC-0	S/HC-0	S/HC-0	S/HC-0	S/HC-0	S/HC-0	S/HC-0	S/HC-0
TXREQ[23:16]							
bit 7				bit 0			

<b>Legend:</b>	S = Settable bit	HC = Hardware Clearable bit
R = Readable bit	W = Writable bit	U = Unimplemented bit, read as '0'
-n = Value at POR	'1' = Bit is set	'0' = Bit is cleared      x = Bit is unknown

bit 15-0      **TXREQ[31:16]:** Unimplemented

## REGISTER 11-26: C1TXREQL: CAN TRANSMIT REQUEST REGISTER LOW

S/HC-0	S/HC-0	S/HC-0	S/HC-0	S/HC-0	S/HC-0	S/HC-0	S/HC-0
TXREQ[15:8]							
bit 15				bit 8			

S/HC-0	S/HC-0	S/HC-0	S/HC-0	S/HC-0	S/HC-0	S/HC-0	S/HC-0
TXREQ[7:1]						TXREQ0	
bit 7				bit 0			

<b>Legend:</b>	S = Settable bit	HC = Hardware Clearable bit
R = Readable bit	W = Writable bit	U = Unimplemented bit, read as '0'
-n = Value at POR	'1' = Bit is set	'0' = Bit is cleared      x = Bit is unknown

bit 15-8      **TXREQ[15:8]:** Unimplemented

bit 7-1      **TXREQ[7:1]:** Message Send Request bits

TXEN = 1 (object configured as a transmit object):

Setting this bit to '1' requests sending a message. The bit will automatically clear when the message(s) queued in the object is (are) successfully sent. This bit can NOT be used for aborting a transmission.

TXEN = 0 (object configured as a receive object):

This bit has no effect.

bit 0      **TXREQ0:** Transmit Queue Message Send Request bit

Setting this bit to '1' requests sending a message. The bit will automatically clear when the message(s) queued in the object is (are) successfully sent. This bit can NOT be used for aborting a transmission.



# dsPIC33CK256MP508 FAMILY

## REGISTER 11-27: C1FIFOBH: CAN MESSAGE MEMORY BASE ADDRESS REGISTER HIGH

R/W-0	R/W-0	R/W-0	R/W-0	R/W-0	R/W-0	R/W-0	R/W-0
FIFOBH[31:24]							
bit 15							bit 8

R/W-0	R/W-0	R/W-0	R/W-0	R/W-0	R/W-0	R/W-0	R/W-0
FIFOBH[23:16]							
bit 7							bit 0

### Legend:

R = Readable bit

W = Writable bit

U = Unimplemented bit, read as '0'

-n = Value at POR

'1' = Bit is set

'0' = Bit is cleared

x = Bit is unknown

bit 15-0

**FIFOBH[31:16]:** Message Memory Base Address bits

Defines the base address for the transmit event FIFO followed by the message objects.

## REGISTER 11-28: C1FIFOBAL: CAN MESSAGE MEMORY BASE ADDRESS REGISTER LOW

R/W-0	R/W-0	R/W-0	R/W-0	R/W-0	R/W-0	R/W-0	R/W-0
FIFOBAL[15:8]							
bit 15							bit 8

R/W-0	R/W-0	R/W-0	R/W-0	R/W-0	R/W-0	R-0 <sup>(1)</sup>	R-0 <sup>(1)</sup>
FIFOBAL[7:0]							
bit 7							bit 0

### Legend:

R = Readable bit

W = Writable bit

U = Unimplemented bit, read as '0'

-n = Value at POR

'1' = Bit is set

'0' = Bit is cleared

x = Bit is unknown

bit 15-0

**FIFOBAL[15:0]:** Message Memory Base Address bits<sup>(1)</sup>

Defines the base address for the transmit event FIFO followed by the message objects.

**Note 1:** Bits[1:0] are '0' to make base address location 32-bit word-aligned.

# dsPIC33CK256MP508 FAMILY

## REGISTER 11-29: C1TXQCONH: CAN TRANSMIT QUEUE CONTROL REGISTER HIGH

R/W-0	R/W-0	R/W-0	R/W-0	R/W-0	R/W-0	R/W-0	R/W-0
PLSIZE2 <sup>(1)</sup>	PLSIZE1 <sup>(1)</sup>	PLSIZE0 <sup>(1)</sup>	FSIZE4 <sup>(1)</sup>	FSIZE3 <sup>(1)</sup>	FSIZE2 <sup>(1)</sup>	FSIZE1 <sup>(1)</sup>	FSIZE0 <sup>(1)</sup>
bit 15							bit 8

U-0	R/W-1	R/W-1	R/W-0	R/W-0	R/W-0	R/W-0	R/W-0
—	TXAT1	TXAT0	TXPRI4	TXPRI3	TXPRI2	TXPRI1	TXPRI0
bit 7							bit 0

### Legend:

R = Readable bit                      W = Writable bit                      U = Unimplemented bit, read as '0'  
 -n = Value at POR                      '1' = Bit is set                      '0' = Bit is cleared                      x = Bit is unknown

bit 15-13      **PLSIZE[2:0]:** Payload Size bits<sup>(1)</sup>

111 = 64 data bytes  
 110 = 48 data bytes  
 101 = 32 data bytes  
 100 = 24 data bytes  
 011 = 20 data bytes  
 010 = 16 data bytes  
 001 = 12 data bytes  
 000 = 8 data bytes

bit 12-8      **FSIZE[4:0]:** FIFO Size bits<sup>(1)</sup>

11111 = FIFO is 32 messages deep  
 ...  
 00010 = FIFO is 3 messages deep  
 00001 = FIFO is 2 messages deep  
 00000 = FIFO is 1 message deep

bit 7      **Unimplemented:** Read as '0'

bit 6-5      **TXAT[1:0]:** Retransmission Attempts bits

This feature is enabled when RTXAT (C1CONH[0]) is set.  
 11 = Unlimited number of retransmission attempts  
 10 = Unlimited number of retransmission attempts  
 01 = Three retransmission attempts  
 00 = Disables retransmission attempts

bit 4-0      **TXPRI[4:0]:** Message Transmit Priority bits

11111 = Highest message priority  
 ...  
 00000 = Lowest message priority

**Note 1:** These bits can only be modified in Configuration mode (OPMOD[2:0] = 100).

# dsPIC33CK256MP508 FAMILY

## REGISTER 11-30: C1TXQCONL: CAN TRANSMIT QUEUE CONTROL REGISTER LOW

U-0	U-0	U-0	U-0	U-0	R/W-0	R/W-0	R/W-0
—	—	—	—	—	FRESET	TXREQ	UINC
bit 15						bit 8	

R-0	U-0	U-0	R/W-0	U-0	R/W-0	U-0	R/W-0
TXEN	—	—	TXATIE	—	TXQEIE	—	TXQNIE
bit 7						bit 0	

### Legend:

R = Readable bit                      W = Writable bit                      U = Unimplemented bit, read as '0'  
 -n = Value at POR                      '1' = Bit is set                      '0' = Bit is cleared                      x = Bit is unknown

- bit 15-11      **Unimplemented:** Read as '0'
- bit 10      **FRESET:** FIFO Reset bit  
             1 = FIFO will be reset when bit is set, cleared by hardware when FIFO is reset; user should poll whether this bit is clear before taking any action  
             0 = No effect
- bit 9      **TXREQ:** Message Send Request bit  
             1 = Requests sending a message; the bit will automatically clear when all the messages queued in the TXQ are successfully sent  
             0 = Clearing the bit to '0' while set ('1') will request a message abort
- bit 8      **UINC:** Increment Head/Tail bit  
             When this bit is set, the FIFO head will increment by a single message.
- bit 7      **TXEN:** TX Enable bit
- bit 6-5      **Unimplemented:** Read as '0'
- bit 4      **TXATIE:** Transmit Attempts Exhausted Interrupt Enable bit  
             1 = Enables interrupt  
             0 = Disables interrupt
- bit 3      **Unimplemented:** Read as '0'
- bit 2      **TXQEIE:** Transmit Queue Empty Interrupt Enable bit  
             1 = Interrupt is enabled for TXQ empty  
             0 = Interrupt is disabled for TXQ empty
- bit 1      **Unimplemented:** Read as '0'
- bit 0      **TXQNIE:** Transmit Queue Not Full Interrupt Enable bit  
             1 = Interrupt is enabled for TXQ not full  
             0 = Interrupt is disabled for TXQ not full

# dsPIC33CK256MP508 FAMILY

## REGISTER 11-31: C1TXQSTA: CAN TRANSMIT QUEUE STATUS REGISTER

U-0	U-0	U-0	R-0	R-0	R-0	R-0	R-0
—	—	—	TXQCI[4:0] <sup>(1)</sup>				
bit 15							bit 8

R-0	R-0	R-0	C/HS-0	U-0	R-1	U-0	R-1
TXABT <sup>(2)</sup>	TXLARB	TXERR	TXATIF	—	TXQEIF	—	TXQNIF
bit 7							bit 0

<b>Legend:</b>	C = Clearable bit	HS = Hardware Settable bit
R = Readable bit	W = Writable bit	U = Unimplemented bit, read as '0'
-n = Value at POR	'1' = Bit is set	'0' = Bit is cleared      x = Bit is unknown

- bit 15-13      **Unimplemented:** Read as '0'
- bit 12-8      **TXQCI[4:0]:** Transmit Message Queue Index bits<sup>(1)</sup>  
A read of this register will return an index to the message that the FIFO will next attempt to transmit.
- bit 7          **TXABT:** Message Aborted Status bit<sup>(2)</sup>  
1 = Message was aborted  
0 = Message completed successfully
- bit 6          **TXLARB:** Message Lost Arbitration Status bit  
1 = Message lost arbitration while being sent  
0 = Message did not lose arbitration while being sent
- bit 5          **TXERR:** Error Detected During Transmission bit  
1 = A bus error occurred while the message was being sent  
0 = A bus error did not occur while the message was being sent
- bit 4          **TXATIF:** Transmit Attempts Exhausted Interrupt Pending bit  
1 = Interrupt is pending  
0 = Interrupt is not pending
- bit 3          **Unimplemented:** Read as '0'
- bit 2          **TXQEIF:** Transmit Queue Empty Interrupt Flag bit  
1 = TXQ is empty  
0 = TXQ is not empty, at least 1 message is queued to be transmitted
- bit 1          **Unimplemented:** Read as '0'
- bit 0          **TXQNIF:** Transmit Queue Not Full Interrupt Flag bit  
1 = TXQ is not full  
0 = TXQ is full

- Note 1:** The TXQCI[4:0] bits give a zero-indexed value to the message in the TXQ. If the TXQ is four messages deep (FSIZE[4:0] = 3), TXQCIx will take on a value of 0 to 3, depending on the state of the TXQ.
- Note 2:** This bit is updated when a message completes (or aborts) or when the TXQ is reset.

# dsPIC33CK256MP508 FAMILY

## REGISTER 11-32: C1FIFOCONHx: CAN FIFO CONTROL REGISTER x (x = 1 TO 7) HIGH

R/W-0	R/W-0	R/W-0	R/W-0	R/W-0	R/W-0	R/W-0	R/W-0
PLSIZE2 <sup>(1)</sup>	PLSIZE1 <sup>(1)</sup>	PLSIZE0 <sup>(1)</sup>	FSIZE4 <sup>(1)</sup>	FSIZE3 <sup>(1)</sup>	FSIZE2 <sup>(1)</sup>	FSIZE1 <sup>(1)</sup>	FSIZE0 <sup>(1)</sup>
bit 15							bit 8

U-0	R/W-1	R/W-1	R/W-0	R/W-0	R/W-0	R/W-0	R/W-0
—	TXAT1	TXAT0	TXPRI4	TXPRI3	TXPRI2	TXPRI1	TXPRI0
bit 7							bit 0

### Legend:

R = Readable bit                      W = Writable bit                      U = Unimplemented bit, read as '0'  
 -n = Value at POR                      '1' = Bit is set                      '0' = Bit is cleared                      x = Bit is unknown

bit 15-13      **PLSIZE[2:0]:** Payload Size bits<sup>(1)</sup>

111 = 64 data bytes  
 110 = 48 data bytes  
 101 = 32 data bytes  
 100 = 24 data bytes  
 011 = 20 data bytes  
 010 = 16 data bytes  
 001 = 12 data bytes  
 000 = 8 data bytes

bit 12-8      **FSIZE[4:0]:** FIFO Size bits<sup>(1)</sup>

11111 = FIFO is 32 messages deep  
 ...  
 00010 = FIFO is 3 messages deep  
 00001 = FIFO is 2 messages deep  
 00000 = FIFO is 1 message deep

bit 7      **Unimplemented:** Read as '0'

bit 6-5      **TXAT[1:0]:** Retransmission Attempts bits

This feature is enabled when RTXAT (C1CONH[0]) is set.  
 11 = Unlimited number of retransmission attempts  
 10 = Unlimited number of retransmission attempts  
 01 = Three retransmission attempts  
 00 = Disables retransmission attempts

bit 4-0      **TXPRI[4:0]:** Message Transmit Priority bits

11111 = Highest message priority  
 ...  
 00000 = Lowest message priority

**Note 1:** These bits can only be modified in Configuration mode (OPMOD[2:0] = 100).

# dsPIC33CK256MP508 FAMILY

## REGISTER 11-33: C1FIFOCONLx: CAN FIFO CONTROL REGISTER x (x = 1 TO 7) LOW

U-0	U-0	U-0	U-0	U-0	S/HC-1	R/W/HC-0	S/HC-0
—	—	—	—	—	FRESET	TXREQ	UINC
bit 15						bit 8	

R/W-0	R/W-0	R/W-0	R/W-0	R/W-0	R/W-0	R/W-0	R/W-0
TXEN	RTREN	RXTSEN <sup>(1)</sup>	TXATIE	RXOVIE	TFERFFIE	TFHRFHIE	TFNRFNIE
bit 7						bit 0	

<b>Legend:</b>	S = Settable bit	HC = Hardware Clearable bit
R = Readable bit	W = Writable bit	U = Unimplemented bit, read as '0'
-n = Value at POR	'1' = Bit is set	'0' = Bit is cleared      x = Bit is unknown

bit 15-11      **Unimplemented:** Read as '0'

bit 10      **FRESET:** FIFO Reset bit

1 = FIFO will be reset when bit is set, cleared by hardware when FIFO is reset; user should poll whether this bit is clear before taking any action

0 = No effect

bit 9      **TXREQ:** Message Send Request bit

TXEN = 1 (FIFO configured as a transmit FIFO):

1 = Requests sending a message; the bit will automatically clear when all the messages queued in the FIFO are successfully sent

0 = Clearing the bit to '0' while set ('1') will request a message abort

TXEN = 0 (FIFO configured as a receive FIFO):

This bit has no effect.

bit 8      **UINC:** Increment Head/Tail bit

TXEN = 1 (FIFO configured as a transmit FIFO):

When this bit is set, the FIFO head will increment by a single message.

TXEN = 0 (FIFO configured as a receive FIFO):

When this bit is set, the FIFO tail will increment by a single message.

bit 7      **TXEN:** TX/RX Buffer Selection bit

1 = Transmits message object

0 = Receives message object

bit 6      **RTREN:** Auto-Remote Transmit (RTR) Enable bit

1 = When a Remote Transmit is received, TXREQ will be set

0 = When a Remote Transmit is received, TXREQ will be unaffected

bit 5      **RXTSEN:** Received Message Timestamp Enable bit<sup>(1)</sup>

1 = Captures timestamp in received message object in RAM

0 = Does not capture timestamp

bit 4      **TXATIE:** Transmit Attempts Exhausted Interrupt Enable bit

1 = Enables interrupt

0 = Disables interrupt

bit 3      **RXOVIE:** Overflow Interrupt Enable bit

1 = Interrupt is enabled for overflow event

0 = Interrupt is disabled for overflow event

**Note 1:** This bit can only be modified in Configuration mode (OPMOD[2:0] = 100).

# dsPIC33CK256MP508 FAMILY

---

---

## REGISTER 11-33: C1FIFOCONLx: CAN FIFO CONTROL REGISTER x (x = 1 TO 7) LOW (CONTINUED)

- bit 2      **TFERFFIE:** Transmit/Receive FIFO Empty/Full Interrupt Enable bit  
TXEN = 1 (FIFO configured as a transmit FIFO):  
Transmit FIFO Empty Interrupt Enable  
1 = Interrupt is enabled for FIFO empty  
0 = Interrupt is disabled for FIFO empty  
TXEN = 0 (FIFO configured as a receive FIFO):  
Receive FIFO Full Interrupt Enable  
1 = Interrupt is enabled for FIFO full  
0 = Interrupt is disabled for FIFO full
- bit 1      **TFHRFHIE:** Transmit/Receive FIFO Half Empty/Half Full Interrupt Enable bit  
TXEN = 1 (FIFO configured as a transmit FIFO):  
Transmit FIFO Half Empty Interrupt Enable  
1 = Interrupt is enabled for FIFO half empty  
0 = Interrupt is disabled for FIFO half empty  
TXEN = 0 (FIFO configured as a receive FIFO):  
Receive FIFO Half Full Interrupt Enable  
1 = Interrupt is enabled for FIFO half full  
0 = Interrupt is disabled for FIFO half full
- bit 0      **TFNRFNIE:** Transmit/Receive FIFO Not Full/Not Empty Interrupt Enable bit  
TXEN = 1 (FIFO configured as a transmit FIFO):  
Transmit FIFO Not Full Interrupt Enable  
1 = Interrupt is enabled for FIFO not full  
0 = Interrupt is disabled for FIFO not full  
TXEN = 0 (FIFO configured as a receive FIFO):  
Receive FIFO Not Empty Interrupt Enable  
1 = Interrupt is enabled for FIFO not empty  
0 = Interrupt is disabled for FIFO not empty

**Note 1:** This bit can only be modified in Configuration mode (OPMOD[2:0] = 100).

# dsPIC33CK256MP508 FAMILY

## REGISTER 11-34: C1FIFOSTAx: CAN FIFO STATUS REGISTER x (x = 1 TO 7)

U-0	U-0	U-0	R-0	R-0	R-0	R-0	R-0
—	—	—	FIFOCI[4:0] <sup>(1)</sup>				
bit 15							bit 8

R-0	R-0	R-0	C/HS-0	C/HS-0	R-0	R-0	R-0
TXABT <sup>(3)</sup>	TXLARB <sup>(2)</sup>	TXERR <sup>(2)</sup>	TXATIF	RXOVIF	TFERFFIF	TFHRFHIF	TFNRFNIF
bit 7							bit 0

<b>Legend:</b>	C = Clearable bit	HS = Hardware Settable bit
R = Readable bit	W = Writable bit	U = Unimplemented bit, read as '0'
-n = Value at POR	'1' = Bit is set	'0' = Bit is cleared      x = Bit is unknown

bit 15-13      **Unimplemented:** Read as '0'

bit 12-8      **FIFOCI[4:0]:** FIFO Message Index bits<sup>(1)</sup>

TXEN = 1 (FIFO configured as a transmit buffer):

A read of this register will return an index to the message that the FIFO will next attempt to transmit.

TXEN = 0 (FIFO configured as a receive buffer):

A read of this register will return an index to the message that the FIFO will use to save the next message.

bit 7      **TXABT:** Message Aborted Status bit<sup>(3)</sup>

1 = Message was aborted

0 = Message completed successfully

bit 6      **TXLARB:** Message Lost Arbitration Status bit<sup>(2)</sup>

1 = Message lost arbitration while being sent

0 = Message did not lose arbitration while being sent

bit 5      **TXERR:** Error Detected During Transmission bit<sup>(2)</sup>

1 = A bus error occurred while the message was being sent

0 = A bus error did not occur while the message was being sent

bit 4      **TXATIF:** Transmit Attempts Exhausted Interrupt Pending bit

TXEN = 1 (FIFO configured as a transmit buffer):

1 = Interrupt is pending

0 = Interrupt is not pending

TXEN = 0 (FIFO configured as a receive buffer):

Unused, read as '0'.

bit 3      **RXOVIF:** Receive FIFO Overflow Interrupt Flag bit

TXEN = 1 (FIFO configured as a transmit buffer):

Unused, read as '0'.

TXEN = 0 (FIFO configured as a receive buffer):

1 = Overflow event has occurred

0 = No overflow event has occurred

**Note 1:** FIFOCI[4:0] gives a zero-indexed value to the message in the FIFO. If the FIFO is four messages deep (FSIZE[4:0] = 3), FIFOCIx will take on a value of 0 to 3, depending on the state of the FIFO.

**Note 2:** These bits are updated when a message completes (or aborts) or when the FIFO is reset.

**Note 3:** This bit is reset on any read of this register or when the TXQ is reset. The bits are cleared when TXREQ is set or using an SPI write.



# dsPIC33CK256MP508 FAMILY

## REGISTER 11-34: C1FIFOSTAx: CAN FIFO STATUS REGISTER x (x = 1 TO 7) (CONTINUED)

- bit 2      **TFERFFIF:** Transmit/Receive FIFO Empty/Full Interrupt Flag bit  
TXEN = 1 (FIFO configured as a transmit FIFO):  
Transmit FIFO Empty Interrupt Flag  
1 = FIFO is empty  
0 = FIFO is not empty, at least one message is queued to be transmitted  
TXEN = 0 (FIFO configured as a receive FIFO):  
Receive FIFO Full Interrupt Flag  
1 = FIFO is full  
0 = FIFO is not full
- bit 1      **TFHRFHIF:** Transmit/Receive FIFO Half Empty/Half Full Interrupt Flag bit  
TXEN = 1 (FIFO configured as a transmit FIFO):  
Transmit FIFO Half Empty Interrupt Flag  
1 = FIFO is  $\leq$  half full  
0 = FIFO is  $>$  half full  
TXEN = 0 (FIFO configured as a receive FIFO):  
Receive FIFO Half Full Interrupt Flag  
1 = FIFO is  $\geq$  half full  
0 = FIFO is  $<$  half full
- bit 0      **TFNRFNIF:** Transmit/Receive FIFO Not Full/Not Empty Interrupt Flag bit  
TXEN = 1 (FIFO configured as a transmit FIFO):  
Transmit FIFO Not Full Interrupt Flag  
1 = FIFO is not full  
0 = FIFO is full  
TXEN = 0 (FIFO configured as a receive FIFO):  
Receive FIFO Not Empty Interrupt Flag  
1 = FIFO is not empty, has at least 1 message  
0 = FIFO is empty

- Note 1:** FIFOCI[4:0] gives a zero-indexed value to the message in the FIFO. If the FIFO is four messages deep (FSIZE[4:0] = 3), FIFOCIx will take on a value of 0 to 3, depending on the state of the FIFO.
- 2:** These bits are updated when a message completes (or aborts) or when the FIFO is reset.
- 3:** This bit is reset on any read of this register or when the TXQ is reset. The bits are cleared when TXREQ is set or using an SPI write.

# dsPIC33CK256MP508 FAMILY

## REGISTER 11-35: C1TEFCONH: CAN TRANSMIT EVENT FIFO CONTROL REGISTER HIGH

U-0	U-0	U-0	R/W-0	R/W-0	R/W-0	R/W-0	R/W-0
—	—	—	FSIZE[4:0] <sup>(1)</sup>				
bit 15							bit 8

U-0	U-0	U-0	U-0	U-0	U-0	U-0	U-0
—	—	—	—	—	—	—	—
bit 7							bit 0

### Legend:

R = Readable bit	W = Writable bit	U = Unimplemented bit, read as '0'
-n = Value at POR	'1' = Bit is set	'0' = Bit is cleared
		x = Bit is unknown

bit 15-13     **Unimplemented:** Read as '0'

bit 12-8     **FSIZE[4:0]:** FIFO Size bits<sup>(1)</sup>  
 11111 = FIFO is 32 messages deep  
 . . .  
 00010 = FIFO is 3 messages deep  
 00001 = FIFO is 2 messages deep  
 00000 = FIFO is 1 message deep

bit 7-0     **Unimplemented:** Read as '0'

**Note 1:** These bits can only be modified in Configuration mode (OPMOD[2:0] = 100).

# dsPIC33CK256MP508 FAMILY

## REGISTER 11-36: C1TEFCONL: CAN TRANSMIT EVENT FIFO CONTROL REGISTER LOW

U-0	U-0	U-0	U-0	U-0	S/HC-0	U-0	S/HC-0
—	—	—	—	—	FRESET	—	UINC
bit 15						bit 8	

U-0	U-0	R/W-0	U-0	R/W-0	R/W-0	R/W-0	R/W-0
—	—	TEFTSEN <sup>(1)</sup>	—	TEFOVIE	TEFFIE	TEFHIE	TEFNEIE
bit 7						bit 0	

<b>Legend:</b>	S = Settable bit	HC = Hardware Clearable bit
R = Readable bit	W = Writable bit	U = Unimplemented bit, read as '0'
-n = Value at POR	'1' = Bit is set	'0' = Bit is cleared
		x = Bit is unknown

- bit 15-11 **Unimplemented:** Read as '0'
- bit 10 **FRESET:** FIFO Reset bit  
 1 = FIFO will be reset when bit is set, cleared by hardware when FIFO is reset; the user should poll whether this bit is clear before taking any action  
 0 = No effect
- bit 9 **Unimplemented:** Read as '0'
- bit 8 **UINC:** Increment Tail bit  
 1 = When this bit is set, the FIFO tail will increment by a single message  
 0 = FIFO tail will not increment
- bit 7-6 **Unimplemented:** Read as '0'
- bit 5 **TEFTSEN:** Transmit Event FIFO Timestamp Enable bit<sup>(1)</sup>  
 1 = Timestamps elements in TEF  
 0 = Does not timestamp elements in TEF
- bit 4 **Unimplemented:** Read as '0'
- bit 3 **TEFOVIE:** Transmit Event FIFO Overflow Interrupt Enable bit  
 1 = Interrupt is enabled for overflow event  
 0 = Interrupt is disabled for overflow event
- bit 2 **TEFFIE:** Transmit Event FIFO Full Interrupt Enable bit  
 1 = Interrupt is enabled for FIFO full  
 0 = Interrupt is disabled for FIFO full
- bit 1 **TEFHIE:** Transmit Event FIFO Half Full Interrupt Enable bit  
 1 = Interrupt is enabled for FIFO half full  
 0 = Interrupt is disabled for FIFO half full
- bit 0 **TEFNEIE:** Transmit Event FIFO Not Empty Interrupt Enable bit  
 1 = Interrupt is enabled for FIFO not empty  
 0 = Interrupt is disabled for FIFO not empty

**Note 1:** These bits can only be modified in Configuration mode (OPMOD[2:0] = 100).

# dsPIC33CK256MP508 FAMILY

## REGISTER 11-37: C1TEFSTA: CAN TRANSMIT EVENT FIFO STATUS REGISTER

U-0	U-0	U-0	U-0	U-0	U-0	U-0	U-0
—	—	—	—	—	—	—	—
bit 15						bit 8	

U-0	U-0	U-0	U-0	S/HC-0	R-0	R-0	R-0
—	—	—	—	TEFOVIF	TEFFIF <sup>(1)</sup>	TEFHIF <sup>(1)</sup>	TEFNEIF <sup>(1)</sup>
bit 7						bit 0	

<b>Legend:</b>	HC = Hardware Clearable bit	S = Settable bit Can Set by '1'
R = Readable bit	W = Writable bit	U = Unimplemented bit, read as '0'
-n = Value at POR	'1' = Bit is set	'0' = Bit is cleared
		x = Bit is unknown

- bit 15-4      **Unimplemented:** Read as '0'
- bit 3        **TEFOVIF:** Transmit Event FIFO Overflow Interrupt Flag bit
  - 1 = Overflow event has occurred
  - 0 = No overflow event has occurred
- bit 2        **TEFFIF:** Transmit Event FIFO Full Interrupt Flag bit<sup>(1)</sup>
  - 1 = FIFO is full
  - 0 = FIFO is not full
- bit 1        **TEFHIF:** Transmit Event FIFO Half Full Interrupt Flag bit<sup>(1)</sup>
  - 1 = FIFO is ≥ half full
  - 0 = FIFO is < half full
- bit 0        **TEFNEIF:** Transmit Event FIFO Not Empty Interrupt Flag bit<sup>(1)</sup>
  - 1 = FIFO is not empty
  - 0 = FIFO is empty

**Note 1:** These bits are read-only and reflect the status of the FIFO.

# dsPIC33CK256MP508 FAMILY

## REGISTER 11-38: C1FIFOUAHx: CAN FIFO USER ADDRESS REGISTER x (x = 1 TO 7) HIGH<sup>(1)</sup>

R-x	R-x	R-x	R-x	R-x	R-x	R-x	R-x
FIFOUA[31:24]							
bit 15				bit 8			

R-x	R-x	R-x	R-x	R-x	R-x	R-x	R-x
FIFOUA[23:16]							
bit 7				bit 0			

### Legend:

R = Readable bit

W = Writable bit

U = Unimplemented bit, read as '0'

-n = Value at POR

'1' = Bit is set

'0' = Bit is cleared

x = Bit is unknown

bit 15-0 **FIFOUA[31:16]:** FIFO User Address bits

TXEN = 1 (FIFO configured as a transmit buffer):

A read of this register will return the address where the next message is to be written (FIFO head).

TXEN = 0 (FIFO configured as a receive buffer):

A read of this register will return the address where the next message is to be read (FIFO tail).

**Note 1:** This register is not ensured to read correctly in Configuration mode and should only be accessed when the module is not in Configuration mode.

## REGISTER 11-39: C1FIFOUALx: CAN FIFO USER ADDRESS REGISTER x (x = 1 TO 7) LOW<sup>(1)</sup>

R-x	R-x	R-x	R-x	R-x	R-x	R-x	R-x
FIFOUA[15:8]							
bit 15				bit 8			

R-x	R-x	R-x	R-x	R-x	R-x	R-x	R-x
FIFOUA[7:0]							
bit 7				bit 0			

### Legend:

R = Readable bit

W = Writable bit

U = Unimplemented bit, read as '0'

-n = Value at POR

'1' = Bit is set

'0' = Bit is cleared

x = Bit is unknown

bit 15-0 **FIFOUA[15:0]:** FIFO User Address bits

TXEN = 1 (FIFO configured as a transmit buffer):

A read of this register will return the address where the next message is to be written (FIFO head).

TXEN = 0 (FIFO configured as a receive buffer):

A read of this register will return the address where the next message is to be read (FIFO tail).

**Note 1:** This register is not ensured to read correctly in Configuration mode and should only be accessed when the module is not in Configuration mode.

# dsPIC33CK256MP508 FAMILY

## REGISTER 11-40: C1TEFUAH: CAN TRANSMIT EVENT FIFO USER ADDRESS REGISTER HIGH<sup>(1)</sup>

R-x	R-x	R-x	R-x	R-x	R-x	R-x	R-x
TEFUA[31:24]							
bit 15				bit 8			

R-x	R-x	R-x	R-x	R-x	R-x	R-x	R-x
TEFUA[23:16]							
bit 7				bit 0			

### Legend:

R = Readable bit                      W = Writable bit                      U = Unimplemented bit, read as '0'  
-n = Value at POR                      '1' = Bit is set                      '0' = Bit is cleared                      x = Bit is unknown

bit 15-0                      **TEFUA[31:16]:** Transmit Event FIFO User Address bits

A read of this register will return the address where the next event is to be read (FIFO tail).

**Note 1:** This register is not ensured to read correctly in Configuration mode and should only be accessed when the module is not in Configuration mode.

## REGISTER 11-41: C1TEFUL: CAN TRANSMIT EVENT FIFO USER ADDRESS REGISTER LOW<sup>(1)</sup>

R-x	R-x	R-x	R-x	R-x	R-x	R-x	R-x
TEFUL[15:8]							
bit 15				bit 8			

R-x	R-x	R-x	R-x	R-x	R-x	R-x	R-x
TEFUL[7:0]							
bit 7				bit 0			

### Legend:

R = Readable bit                      W = Writable bit                      U = Unimplemented bit, read as '0'  
-n = Value at POR                      '1' = Bit is set                      '0' = Bit is cleared                      x = Bit is unknown

bit 15-0                      **TEFUL[15:0]:** Transmit Event FIFO User Address bits

A read of this register will return the address where the next event is to be read (FIFO tail).

**Note 1:** This register is not ensured to read correctly in Configuration mode and should only be accessed when the module is not in Configuration mode.

# dsPIC33CK256MP508 FAMILY

## REGISTER 11-42: C1TXQUAH: CAN TRANSMIT QUEUE USER ADDRESS REGISTER HIGH<sup>(1)</sup>

R-x	R-x	R-x	R-x	R-x	R-x	R-x	R-x
TXQUA[31:24]							
bit 15							bit 8

R-x	R-x	R-x	R-x	R-x	R-x	R-x	R-x
TXQUA[23:16]							
bit 7							bit 0

### Legend:

R = Readable bit

W = Writable bit

U = Unimplemented bit, read as '0'

-n = Value at POR

'1' = Bit is set

'0' = Bit is cleared

x = Bit is unknown

bit 15-0 **TXQUA[31:16]:** TXQ User Address bits

A read of this register will return the address where the next message is to be written (TXQ head).

**Note 1:** This register is not ensured to read correctly in Configuration mode and should only be accessed when the module is not in Configuration mode.

## REGISTER 11-43: C1TXQUAL: CAN TRANSMIT QUEUE USER ADDRESS REGISTER LOW<sup>(1)</sup>

R-x	R-x	R-x	R-x	R-x	R-x	R-x	R-x
TXQUA[15:8]							
bit 15							bit 8

R-x	R-x	R-x	R-x	R-x	R-x	R-x	R-x
TXQUA[7:0]							
bit 7							bit 0

### Legend:

R = Readable bit

W = Writable bit

U = Unimplemented bit, read as '0'

-n = Value at POR

'1' = Bit is set

'0' = Bit is cleared

x = Bit is unknown

bit 15-0 **TXQUA[15:0]:** TXQ User Address bits

A read of this register will return the address where the next message is to be written (TXQ head).

**Note 1:** This register is not ensured to read correctly in Configuration mode and should only be accessed when the module is not in Configuration mode.

# dsPIC33CK256MP508 FAMILY

## REGISTER 11-44: C1TRECH: CAN TRANSMIT/RECEIVE ERROR COUNT REGISTER HIGH

U-0	U-0	U-0	U-0	U-0	U-0	U-0	U-0
—	—	—	—	—	—	—	—
bit 15							bit 8

U-0	U-0	R-1	R-0	R-0	R-0	R-0	R-0
—	—	TXBO	TXBP	RXBP	TXWARN	RXWARN	EWARN
bit 7							bit 0

### Legend:

R = Readable bit                      W = Writable bit                      U = Unimplemented bit, read as '0'  
 -n = Value at POR                      '1' = Bit is set                      '0' = Bit is cleared                      x = Bit is unknown

- bit 15-6        **Unimplemented:** Read as '0'
- bit 5            **TXBO:** Transmitter in Bus Off Error State bit (TERRCNT[7:0] > 255)  
                   In Configuration mode, TXBO is set since the module is not on the bus.
- bit 4            **TXBP:** Transmitter in Bus Passive Error State bit (TERRCNT[7:0] > 127)
- bit 3            **RXBP:** Receiver in Bus Passive Error State bit (RERRCNT[7:0] > 127)
- bit 2            **TXWARN:** Transmitter in Warning State bit (128 > TERRCNT[7:0] > 95)
- bit 1            **RXWARN:** Receiver in Warning State bit (128 > RERRCNT[7:0] > 95)
- bit 0            **EWARN:** Transmitter or Receiver in Warning State bit

## REGISTER 11-45: C1TRECL: CAN TRANSMIT/RECEIVE ERROR COUNT REGISTER LOW

R-0	R-0	R-0	R-0	R-0	R-0	R-0	R-0
TERRCNT[7:0]							
bit 15							bit 8

R-0	R-0	R-0	R-0	R-0	R-0	R-0	R-0
RERRCNT[7:0]							
bit 7							bit 0

### Legend:

R = Readable bit                      W = Writable bit                      U = Unimplemented bit, read as '0'  
 -n = Value at POR                      '1' = Bit is set                      '0' = Bit is cleared                      x = Bit is unknown

- bit 15-8        **TERRCNT[7:0]:** Transmit Error Counter bits
- bit 7-0         **RERRCNT[7:0]:** Receive Error Counter bits



# dsPIC33CK256MP508 FAMILY

## REGISTER 11-46: C1BDIAG0H: CAN BUS DIAGNOSTICS REGISTER 0 HIGH

R/W-0	R/W-0	R/W-0	R/W-0	R/W-0	R/W-0	R/W-0	R/W-0
DTERRCNT[7:0]							
bit 15				bit 8			

R/W-0	R/W-0	R/W-0	R/W-0	R/W-0	R/W-0	R/W-0	R/W-0
DRERRCNT[7:0]							
bit 7				bit 0			

### Legend:

R = Readable bit                      W = Writable bit                      U = Unimplemented bit, read as '0'  
-n = Value at POR                      '1' = Bit is set                      '0' = Bit is cleared                      x = Bit is unknown

bit 15-8        **DTERRCNT[7:0]**: Data Bit Rate Transmit Error Counter bits

bit 7-0        **DRERRCNT[7:0]**: Data Bit Rate Receive Error Counter bits

## REGISTER 11-47: C1BDIAG0L: CAN BUS DIAGNOSTICS REGISTER 0 LOW

R/W-0	R/W-0	R/W-0	R/W-0	R/W-0	R/W-0	R/W-0	R/W-0
NTERRCNT[7:0]							
bit 15				bit 8			

R/W-0	R/W-0	R/W-0	R/W-0	R/W-0	R/W-0	R/W-0	R/W-0
NRERRCNT[7:0]							
bit 7				bit 0			

### Legend:

R = Readable bit                      W = Writable bit                      U = Unimplemented bit, read as '0'  
-n = Value at POR                      '1' = Bit is set                      '0' = Bit is cleared                      x = Bit is unknown

bit 15-8        **NTERRCNT[7:0]**: Nominal Bit Rate Transmit Error Counter bits

bit 7-0        **NRERRCNT[7:0]**: Nominal Bit Rate Receive Error Counter bits

# dsPIC33CK256MP508 FAMILY

## REGISTER 11-48: C1BDIAG1H: CAN BUS DIAGNOSTICS REGISTER 1 HIGH

R/W-0	R/W-0	R/C-0	R/W-0	R/W-0	U-0	R/W-0	R/W-0
DLCMM	ESI	DCRCERR	DSTUFERR	DFORMERR	—	DBIT1ERR	DBIT0ERR
bit 15							bit 8

R/W-0	U-0	R/W-0	R/W-0	R/W-0	R/W-0	R/W-0	R/W-0
TXBOERR	—	NCRCERR	NSTUFERR	NFORMERR	NACKERR	NBIT1ERR	NBIT0ERR
bit 7							bit 0

<b>Legend:</b>	C = Clearable bit		
R = Readable bit	W = Writable bit	U = Unimplemented bit, read as '0'	
-n = Value at POR	'1' = Bit is set	'0' = Bit is cleared	x = Bit is unknown

- bit 15     **DLCMM:** DLC Mismatch bit  
During a transmission or reception, the specified DLC is larger than the PLSIZE[2:0] of the FIFO element.
- bit 14     **ESI:** ESI Flag of a Received CAN FD Message Set bit
- bit 13     **DCRCERR:** Same as for nominal bit rate
- bit 12     **DSTUFERR:** Same as for nominal bit rate
- bit 11     **DFORMERR:** Same as for nominal bit rate
- bit 10     **Unimplemented:** Read as '0'
- bit 9      **DBIT1ERR:** Same as for nominal bit rate
- bit 8      **DBIT0ERR:** Same as for nominal bit rate
- bit 7      **TXBOERR:** Device Went to Bus Off bit (and auto-recovered)
- bit 6      **Unimplemented:** Read as '0'
- bit 5      **NCRCERR:** Received Message with CRC Incorrect Checksum bit  
The CRC checksum of a received message was incorrect. The CRC of an incoming message does not match with the CRC calculated from the received data.
- bit 4      **NSTUFERR:** Received Message with Illegal Sequence bit  
More than 5 equal bits in a sequence have occurred in a part of a received message where this is not allowed.
- bit 3      **NFORMERR:** Received Frame Fixed Format bit  
A fixed format part of a received frame has the wrong format.
- bit 2      **NACKERR:** Transmitted Message Not Acknowledged bit  
Transmitted message was not acknowledged.
- bit 1      **NBIT1ERR:** Transmitted Message Recessive Level bit  
During the transmission of a message (with the exception of the arbitration field), the device wanted to send a recessive level (bit of logical value '1'), but the monitored bus value was dominant.
- bit 0      **NBIT0ERR:** Transmitted Message Dominant Level bit  
During the transmission of a message (or Acknowledge bit, active error flag or overload flag), the device wanted to send a dominant level (data or identifier bit of logical value '0'), but the monitored bus value was recessive. During bus off recovery, this status is set each time a sequence of 11 recessive bits has been monitored. This enables the CPU to monitor the proceeding of the bus off recovery sequence (indicating the bus is not stuck at dominant or continuously disturbed).

# dsPIC33CK256MP508 FAMILY

## REGISTER 11-49: C1BDIAG1L: CAN BUS DIAGNOSTICS REGISTER 1 LOW

R/W-0	R/W-0	R/W-0	R/W-0	R/W-0	R/W-0	R/W-0	R/W-0
EFMSGCNT[15:8]							
bit 15							bit 8

R/W-0	R/W-0	R/W-0	R/W-0	R/W-0	R/W-0	R/W-0	R/W-0
EFMSGCNT[7:0]							
bit 7							bit 0

### Legend:

R = Readable bit

W = Writable bit

U = Unimplemented bit, read as '0'

-n = Value at POR

'1' = Bit is set

'0' = Bit is cleared

x = Bit is unknown

bit 15-0      **EFMSGCNT[15:0]:** Error-Free Message Counter bits

# dsPIC33CK256MP508 FAMILY

**REGISTER 11-50: C1FLTCONxH: CAN FILTER CONTROL REGISTER x HIGH (x = 0 TO 3;  
c = 2, 6, 10, 14; d = 3, 7, 11, 15)**

R/W-0	U-0	U-0	R/W-0	R/W-0	R/W-0	R/W-0	R/W-0
FLTENDd	—	—	FdBP4	FdBP3	FdBP2	FdBP1	FdBP0
bit 15							bit 8

R/W-0	U-0	U-0	R/W-0	R/W-0	R/W-0	R/W-0	R/W-0
FLTENCc	—	—	FcBP4	FcBP3	FcBP2	FcBP1	FcBP0
bit 7							bit 0

**Legend:**

R = Readable bit	W = Writable bit	U = Unimplemented bit, read as '0'
-n = Value at POR	'1' = Bit is set	'0' = Bit is cleared
		x = Bit is unknown

- bit 15      **FLTENDd:** Enable Filter d to Accept Messages bit  
             1 = Filter is enabled  
             0 = Filter is disabled
- bit 14-13    **Unimplemented:** Read as '0'
- bit 12-8     **FdBP[4:0]:** Pointer to Object When Filter d Hits bits  
             11111 to 11000 = Reserved  
             00111 = Message matching filter is stored in Object 7  
             00110 = Message matching filter is stored in Object 6  
             ...  
             00010 = Message matching filter is stored in Object 2  
             00001 = Message matching filter is stored in Object 1  
             00000 = Reserved; Object 0 is the TX Queue and can't receive messages
- bit 7        **FLTENCc:** Enable Filter c to Accept Messages bit  
             1 = Filter is enabled  
             0 = Filter is disabled
- bit 6-5     **Unimplemented:** Read as '0'
- bit 4-0     **FcBP[4:0]:** Pointer to Object When Filter c Hits bits  
             11111 to 11000 = Reserved  
             00111 = Message matching filter is stored in Object 7  
             00110 = Message matching filter is stored in Object 6  
             ...  
             00010 = Message matching filter is stored in Object 2  
             00001 = Message matching filter is stored in Object 1  
             00000 = Reserved; Object 0 is the TX Queue and can't receive messages

# dsPIC33CK256MP508 FAMILY

## REGISTER 11-51: C1FLTCONxL: CAN FILTER CONTROL REGISTER x LOW (x = 0 TO 3; a = 0, 4, 8, 12; b = 1, 5, 9, 13)

R/W-0	U-0	U-0	R/W-0	R/W-0	R/W-0	R/W-0	R/W-0
FLTENb	—	—	FbBP4	FbBP3	FbBP2	FbBP1	FbBP0
bit 15							bit 8

R/W-0	U-0	U-0	R/W-0	R/W-0	R/W-0	R/W-0	R/W-0
FLTENA	—	—	FaBP4	FaBP3	FaBP2	FaBP1	FaBP0
bit 7							bit 0

### Legend:

R = Readable bit                      W = Writable bit                      U = Unimplemented bit, read as '0'  
 -n = Value at POR                      '1' = Bit is set                      '0' = Bit is cleared                      x = Bit is unknown

- bit 15            **FLTENb**: Enable Filter b to Accept Messages bit  
                   1 = Filter is enabled  
                   0 = Filter is disabled
- bit 14-13       **Unimplemented**: Read as '0'
- bit 12-8        **FbBP[4:0]**: Pointer to Object When Filter b Hits bits  
                   11111 to 11000 = Reserved  
                   00111 = Message matching filter is stored in Object 7  
                   00110 = Message matching filter is stored in Object 6  
                   ...  
                   00010 = Message matching filter is stored in Object 2  
                   00001 = Message matching filter is stored in Object 1  
                   00000 = Reserved; Object 0 is the TX Queue and can't receive messages
- bit 7            **FLTENA**: Enable Filter a to Accept Messages bit  
                   1 = Filter is enabled  
                   0 = Filter is disabled
- bit 6-5        **Unimplemented**: Read as '0'
- bit 4-0        **FaBP[4:0]**: Pointer to Object When Filter a Hits bits  
                   11111 to 11000 = Reserved  
                   00111 = Message matching filter is stored in Object 7  
                   00110 = Message matching filter is stored in Object 6  
                   ...  
                   00010 = Message matching filter is stored in Object 2  
                   00001 = Message matching filter is stored in Object 1  
                   00000 = Reserved; Object 0 is the TX Queue and can't receive messages

# dsPIC33CK256MP508 FAMILY

## REGISTER 11-52: C1FLTOBJxH: CAN FILTER OBJECT REGISTER x HIGH (x = 0 TO 15)

U-0	R/W-0	R/W-0	R/W-0	R/W-0	R/W-0	R/W-0	R/W-0
—	EXIDE	SID11	EID[17:13]				
bit 15							bit 8

R/W-0	R/W-0	R/W-0	R/W-0	R/W-0	R/W-0	R/W-0	R/W-0
EID[12:5]							
bit 7							bit 0

### Legend:

R = Readable bit                      W = Writable bit                      U = Unimplemented bit, read as '0'  
-n = Value at POR                      '1' = Bit is set                      '0' = Bit is cleared                      x = Bit is unknown

- bit 15            **Unimplemented:** Read as '0'
- bit 14            **EXIDE:** Extended Identifier Enable bit  
                    If MIDE = 1:  
                    1 = Matches only messages with Extended Identifier addresses  
                    0 = Matches only messages with Standard Identifier addresses
- bit 13            **SID11:** Standard Identifier Filter bit
- bit 12-0        **EID[17:5]:** Extended Identifier Filter bits  
                    In DeviceNet™ mode, these are the filter bits for the first two data bytes.

## REGISTER 11-53: C1FLTOBJxL: CAN FILTER OBJECT REGISTER x LOW (x = 0 TO 15)

R/W-0	R/W-0	R/W-0	R/W-0	R/W-0	R/W-0	R/W-0	R/W-0
EID[4:0]				SID[10:8]			
bit 15							bit 8

R/W-0	R/W-0	R/W-0	R/W-0	R/W-0	R/W-0	R/W-0	R/W-0
SID[7:0]							
bit 7							bit 0

### Legend:

R = Readable bit                      W = Writable bit                      U = Unimplemented bit, read as '0'  
-n = Value at POR                      '1' = Bit is set                      '0' = Bit is cleared                      x = Bit is unknown

- bit 15-11        **EID[4:0]:** Extended Identifier Filter bits  
                    In DeviceNet™ mode, these are the filter bits for the first two data bytes.
- bit 10-0        **SID[10:0]:** Standard Identifier Filter bits

# dsPIC33CK256MP508 FAMILY

## REGISTER 11-54: C1MASKxH: CAN MASK REGISTER x HIGH (x = 0 TO 15)

U-0	R/W-0	R/W-0	R/W-0	R/W-0	R/W-0	R/W-0	R/W-0
—	MIDE	MSID11	MEID[17:13]				
bit 15							bit 8

R/W-0	R/W-0	R/W-0	R/W-0	R/W-0	R/W-0	R/W-0	R/W-0
MEID[12:5]							
bit 7							bit 0

<b>Legend:</b>			
R = Readable bit	W = Writable bit	U = Unimplemented bit, read as '0'	
-n = Value at POR	'1' = Bit is set	'0' = Bit is cleared	x = Bit is unknown

- bit 15      **Unimplemented:** Read as '0'
- bit 14      **MIDE:** Identifier Receive Mode bit
  - 1 = Matches only message types (standard or extended address) that correspond to the EXIDE bit in the filter
  - 0 = Matches either standard or extended address message if filters match (i.e., if (Filter SID) = (Message SID) or if (Filter SID/EID) = (Message SID/EID))
- bit 13      **MSID11:** Standard Identifier Mask bit
- bit 12-0    **MEID[17:5]:** Extended Identifier Mask bits  
In DeviceNet™ mode, these are the mask bits for the first two data bytes.

## REGISTER 11-55: C1MASKxL: CAN MASK REGISTER x LOW (x = 0 TO 15)

R/W-0	R/W-0	R/W-0	R/W-0	R/W-0	R/W-0	R/W-0	R/W-0
MEID[4:0]				MSID[10:8]			
bit 15							bit 8

R/W-0	R/W-0	R/W-0	R/W-0	R/W-0	R/W-0	R/W-0	R/W-0
MSID[7:0]							
bit 7							bit 0

<b>Legend:</b>			
R = Readable bit	W = Writable bit	U = Unimplemented bit, read as '0'	
-n = Value at POR	'1' = Bit is set	'0' = Bit is cleared	x = Bit is unknown

- bit 15-11    **MEID[4:0]:** Extended Identifier Mask bits  
In DeviceNet™ mode, these are the mask bits for the first two data bytes.
- bit 10-0    **MSID[10:0]:** Standard Identifier Mask bits

# dsPIC33CK256MP508 FAMILY

---

NOTES:



## 12.0 HIGH-RESOLUTION PWM WITH FINE EDGE PLACEMENT

**Note 1:** This data sheet summarizes the features of the dsPIC33CK256MP508 family of devices. It is not intended to be a comprehensive reference source. To complement the information in this data sheet, refer to “**High-Resolution PWM with Fine Edge Placement**” ([www.microchip.com/DS70005320](http://www.microchip.com/DS70005320)) in the “*dsPIC33/PIC24 Family Reference Manual*”.

The High-Speed PWM (HSPWM) module is a Pulse-Width Modulated (PWM) module to support both motor control and power supply applications. This flexible module provides features to support many types of Motor Control (MC) and Power Control (PC) applications, including:

- AC-to-DC Converters
- DC-to-DC Converters
- AC and DC Motors: BLDC, PMSM, ACIM, SRM, etc.
- Inverters
- Battery Chargers
- Digital Lighting
- Power Factor Correction (PFC)

Due to pin limitations, only the larger pin count packages have all eight pairs of PWM outputs available. PWM4H and PWM4L are always available on Peripheral Pin Select (PPS). See [Table 12-1](#) for PWM output availability.

**TABLE 12-1: PWM OUTPUT AVAILABILITY**

Package Type	Total PGx Instances	Dedicated Outputs	Dedicated + PPS Outputs
80-pin	8	8 pairs	8 pairs
64-pin	8	8 pairs	8 pairs
48-pin	8	8 pairs	8 pairs
36-pin	8	5 pairs	6 pairs
28-pin	8	3 pairs	4 pairs

## 12.1 Features

- Eight Independent PWM Generators, each with Dual Outputs
- Operating modes:
  - Independent Edge mode
  - Variable Phase PWM mode
  - Center-Aligned mode
  - Double Update Center-Aligned mode
  - Dual Edge Center-Aligned mode
  - Dual PWM mode
- Output modes:
  - Complementary
  - Independent
  - Push-Pull
- Dead-Time Generator
- Leading-Edge Blanking (LEB)
- Output Override for Fault Handling
- Flexible Period/Duty Cycle Updating Options
- Programmable Control Inputs (PCI)
- Advanced Triggering Options
- Six Combinatorial Logic Outputs
- Six PWM Event Outputs

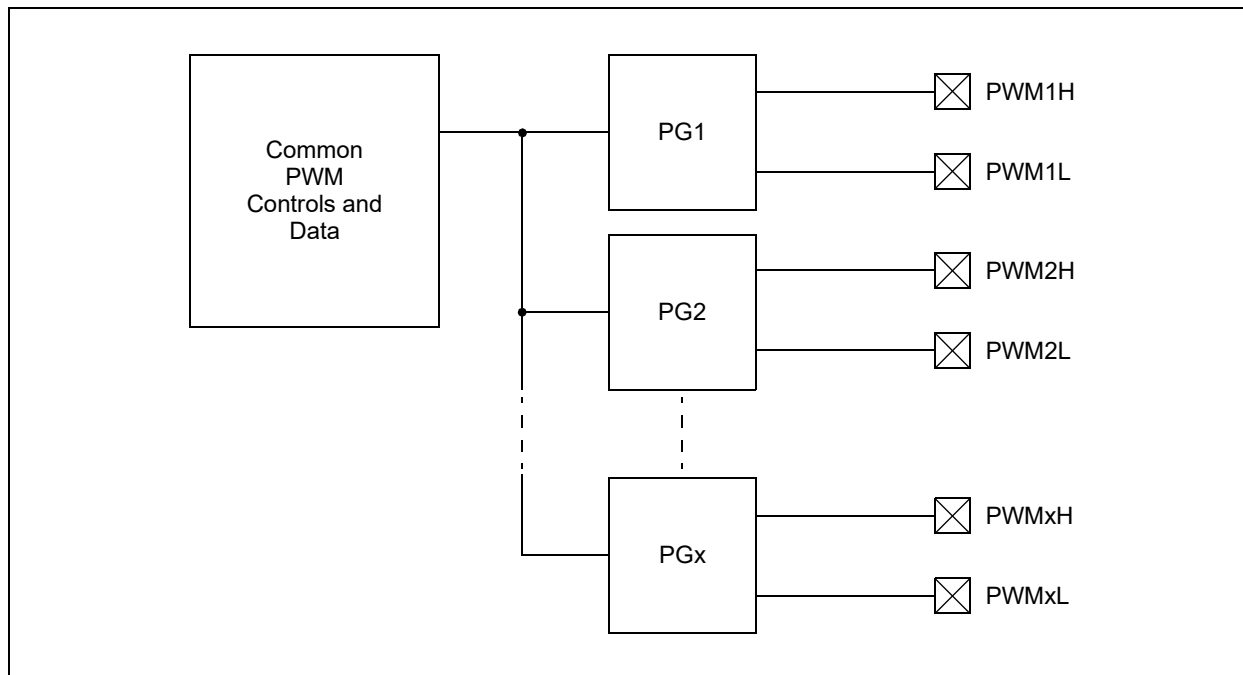
# dsPIC33CK256MP508 FAMILY

## 12.2 Architecture Overview

The PWM module consists of a common set of controls and features, and multiple instantiations of PWM Generators (PGs). Each PWM Generator can be independently configured or multiple PWM Generators can

be used to achieve complex multiphase systems. PWM Generators can also be used to implement sophisticated triggering, protection and logic functions. A high-level block diagram is shown in [Figure 12-1](#).

**FIGURE 12-1: PWM HIGH-LEVEL BLOCK DIAGRAM**



## 12.3 Lock and Write Restrictions

The LOCK bit (PCLKCON[8]) may be set in software to block writes to certain registers. For more information, refer to **“High-Resolution PWM with Fine Edge Placement”** ([www.microchip.com/DS70005320](http://www.microchip.com/DS70005320)) in the *“dsPIC33/PIC24 Family Reference Manual”*.

The following lock/unlock sequence is required to set or clear the LOCK bit.

1. Write 0x55 to NVMKEY.
2. Write 0xAA to NVMKEY.
3. Clear (or set) the LOCK bit (PCLKCON[8]) as a single operation.

In general, modifications to configuration controls should not be done while the module is running, as indicated by the ON bit (PGxCONL[15]) being set.

## 12.4 PWM4H/L Output on Peripheral Pin Select

All devices support the capability to output PWM4H and PWM4L signals via Peripheral Pin Select (PPS) on to any “RPn” pin. This feature is intended for lower pin count devices that do not have PWM4H/L on dedicated pins. If PWM4H/L PPS output functions are used on devices that also have fixed PWM4H/L pins, the output signal will be present on both dedicated and “RPn” pins. The output port enable bits, PENH and PENL (PGxIOCONH[3:2]), control both dedicated and PPS pins together; it is not possible to disable the dedicated pins and use only PPS.

Given the natural priority of the “RPn” functions above that of the PWM, it is possible to use the PPS output functions on the dedicated PWM4H/L pins while the PWM4 signals are routed to other pins via PPS. Any of the peripheral outputs listed in [Table 8-7](#), with the exception of ‘Default Port’, can be used. Input functions, including the ports and peripherals listed in [Table 8-5](#), cannot be used through the “RPn” function on dedicated PWM4H/L pins when PWM4 is active.

# dsPIC33CK256MP508 FAMILY

## 12.5 Control Registers

There are two categories of Special Function Registers (SFRs) used to control the operation of the PWM module:

- Common, shared by all PWM Generators
- PWM Generator-specific

An 'x' in the register name denotes an instance of a PWM Generator.

A 'y' in the register name denotes an instance of the common function.

### REGISTER 12-1: PCLKCON: PWM CLOCK CONTROL REGISTER

R/W-0	R/W-0	U-0	U-0	U-0	U-0	U-0	R/W-0
HRRDY	HRERR	—	—	—	—	—	LOCK <sup>(1)</sup>
bit 15							bit 8

U-0	U-0	R/W-0	R/W-0	U-0	U-0	R/W-0	R/W-0
—	—	DIVSEL1	DIVSEL0	—	—	MCLKSEL1 <sup>(2)</sup>	MCLKSEL0 <sup>(2)</sup>
bit 7							bit 0

#### Legend:

R = Readable bit

W = Writable bit

U = Unimplemented bit, read as '0'

-n = Value at POR

'1' = Bit is set

'0' = Bit is cleared

x = Bit is unknown

bit 15 **HRRDY:** High-Resolution Ready bit  
 1 = The high-resolution circuitry is ready  
 0 = The high-resolution circuitry is not ready

bit 14 **HRERR:** High-Resolution Error bit  
 1 = An error has occurred; PWM signals will have limited resolution  
 0 = No error has occurred; PWM signals will have full resolution when HRRDY = 1

bit 13-9 **Unimplemented:** Read as '0'

bit 8 **LOCK:** Lock bit<sup>(1)</sup>  
 1 = Write-protected registers and bits are locked  
 0 = Write-protected registers and bits are unlocked

bit 7-6 **Unimplemented:** Read as '0'

bit 5-4 **DIVSEL[1:0]:** PWM Clock Divider Selection bits  
 11 = Divide ratio is 1:16  
 10 = Divide ratio is 1:8  
 01 = Divide ratio is 1:4  
 00 = Divide ratio is 1:2

bit 3-2 **Unimplemented:** Read as '0'

bit 1-0 **MCLKSEL[1:0]:** PWM Master Clock Selection bits<sup>(2)</sup>  
 11 = AFPLLO – Auxiliary PLL post-divider output  
 10 = FPLLO – Primary PLL post-divider output  
 01 = AFVCO/2 – Auxiliary VCO/2  
 00 = FOSC

**Note 1:** An unlock sequence must be performed before this bit can be cleared (see [Section 12.3 “Lock and Write Restrictions”](#)).

**2:** Changing the MCLKSEL[1:0] bits while ON (PGxCONL[15]) = 1 is not recommended.

# dsPIC33CK256MP508 FAMILY

## REGISTER 12-2: FSCL: FREQUENCY SCALE REGISTER

R/W-0	R/W-0	R/W-0	R/W-0	R/W-0	R/W-0	R/W-0	R/W-0
FSCL[15:8]							
bit 15				bit 8			

R/W-0	R/W-0	R/W-0	R/W-0	R/W-0	R/W-0	R/W-0	R/W-0
FSCL[7:0]							
bit 7				bit 0			

<b>Legend:</b>							
R = Readable bit	W = Writable bit	U = Unimplemented bit, read as '0'					
-n = Value at POR	'1' = Bit is set	'0' = Bit is cleared	x = Bit is unknown				

bit 15-0      **FSCL[15:0]:** Frequency Scale Register bits  
 The value in this register is added to the frequency scaling accumulator at each pwm\_master\_clk. When the accumulated value exceeds the value of FSMINPER, a clock pulse is produced.

## REGISTER 12-3: FSMINPER: FREQUENCY SCALING MINIMUM PERIOD REGISTER

R/W-0	R/W-0	R/W-0	R/W-0	R/W-0	R/W-0	R/W-0	R/W-0
FSMINPER[15:8]							
bit 15				bit 8			

R/W-0	R/W-0	R/W-0	R/W-0	R/W-0	R/W-0	R/W-0	R/W-0
FSMINPER[7:0]							
bit 7				bit 0			

<b>Legend:</b>							
R = Readable bit	W = Writable bit	U = Unimplemented bit, read as '0'					
-n = Value at POR	'1' = Bit is set	'0' = Bit is cleared	x = Bit is unknown				

bit 15-0      **FSMINPER[15:0]:** Frequency Scaling Minimum Period Register bits  
 This register holds the minimum clock period (maximum clock frequency) that can be produced by the frequency scaling circuit.

# dsPIC33CK256MP508 FAMILY

## REGISTER 12-4: MPHASE: MASTER PHASE REGISTER

R/W-0	R/W-0	R/W-0	R/W-0	R/W-0	R/W-0	R/W-0	R/W-0
MPHASE[15:8]							
bit 15							bit 8

R/W-0	R/W-0	R/W-0	R/W-0	R/W-0	R/W-0	R/W-0	R/W-0
MPHASE[7:0]							
bit 7							bit 0

### Legend:

R = Readable bit                      W = Writable bit                      U = Unimplemented bit, read as '0'  
 -n = Value at POR                      '1' = Bit is set                      '0' = Bit is cleared                      x = Bit is unknown

bit 15-0                      **MPHASE[15:0]:** Master Phase Register bits  
 This register holds the phase offset value that can be shared by multiple PWM Generators.

## REGISTER 12-5: MDC: MASTER DUTY CYCLE REGISTER

R/W-0	R/W-0	R/W-0	R/W-0	R/W-0	R/W-0	R/W-0	R/W-0
MDC[15:8] <sup>(1)</sup>							
bit 15							bit 8

R/W-0	R/W-0	R/W-0	R/W-0	R/W-0	R/W-0	R/W-0	R/W-0
MDC[7:0] <sup>(1)</sup>							
bit 7							bit 0

### Legend:

R = Readable bit                      W = Writable bit                      U = Unimplemented bit, read as '0'  
 -n = Value at POR                      '1' = Bit is set                      '0' = Bit is cleared                      x = Bit is unknown

bit 15-0                      **MDC[15:0]:** Master Duty Cycle Register bits<sup>(1)</sup>  
 This register holds the duty cycle value that can be shared by multiple PWM Generators.

**Note 1:** Duty cycle values less than '0x0008' should not be used ('0x0020' in High-Resolution mode).

# dsPIC33CK256MP508 FAMILY

## REGISTER 12-6: MPER: MASTER PERIOD REGISTER

R/W-0	R/W-0	R/W-0	R/W-0	R/W-0	R/W-0	R/W-0	R/W-0
MPER[15:8] <sup>(1)</sup>							
bit 15							
bit 8							

R/W-0	R/W-0	R/W-0	R/W-0	R/W-0	R/W-0	R/W-0	R/W-0
MPER[7:0] <sup>(1)</sup>							
bit 7							
bit 0							

### Legend:

R = Readable bit

W = Writable bit

U = Unimplemented bit, read as '0'

-n = Value at POR

'1' = Bit is set

'0' = Bit is cleared

x = Bit is unknown

bit 15-0      **MPER[15:0]:** Master Period Register bits<sup>(1)</sup>

This register holds the period value that can be shared by multiple PWM Generators.

**Note 1:** Period values less than '0x0010' should not be used ('0x0080' in High-Resolution mode).

# dsPIC33CK256MP508 FAMILY

## REGISTER 12-7: CMBTRIGL: COMBINATIONAL TRIGGER REGISTER LOW

U-0	U-0	U-0	U-0	U-0	U-0	U-0	U-0
—	—	—	—	—	—	—	—
bit 15							bit 8

R/W-0	R/W-0	R/W-0	R/W-0	R/W-0	R/W-0	R/W-0	R/W-0
CTA8EN	CTA7EN	CTA6EN	CTA5EN	CTA4EN	CTA3EN	CTA2EN	CTA1EN
bit 7							bit 0

### Legend:

R = Readable bit                      W = Writable bit                      U = Unimplemented bit, read as '0'  
 -n = Value at POR                      '1' = Bit is set                      '0' = Bit is cleared                      x = Bit is unknown

- bit 15-8            **Unimplemented:** Read as '0'
- bit 7              **CTA8EN:** Enable Trigger Output from PWM Generator #8 as Source for Combinational Trigger A bit  
                     1 = Enables specified trigger signal to be OR'd into the Combinatorial Trigger A signal  
                     0 = Disabled
- bit 6              **CTA7EN:** Enable Trigger Output from PWM Generator #7 as Source for Combinational Trigger A bit  
                     1 = Enables specified trigger signal to be OR'd into the Combinatorial Trigger A signal  
                     0 = Disabled
- bit 5              **CTA6EN:** Enable Trigger Output from PWM Generator #6 as Source for Combinational Trigger A bit  
                     1 = Enables specified trigger signal to be OR'd into the Combinatorial Trigger A signal  
                     0 = Disabled
- bit 4              **CTA5EN:** Enable Trigger Output from PWM Generator #5 as Source for Combinational Trigger A bit  
                     1 = Enables specified trigger signal to be OR'd into the Combinatorial Trigger A signal  
                     0 = Disabled
- bit 3              **CTA4EN:** Enable Trigger Output from PWM Generator #4 as Source for Combinational Trigger A bit  
                     1 = Enables specified trigger signal to be OR'd into the Combinatorial Trigger A signal  
                     0 = Disabled
- bit 2              **CTA3EN:** Enable Trigger Output from PWM Generator #3 as Source for Combinational Trigger A bit  
                     1 = Enables specified trigger signal to be OR'd into the Combinatorial Trigger A signal  
                     0 = Disabled
- bit 1              **CTA2EN:** Enable Trigger Output from PWM Generator #2 as Source for Combinational Trigger A bit  
                     1 = Enables specified trigger signal to be OR'd into the Combinatorial Trigger A signal  
                     0 = Disabled
- bit 0              **CTA1EN:** Enable Trigger Output from PWM Generator #1 as Source for Combinational Trigger A bit  
                     1 = Enables specified trigger signal to be OR'd into the Combinatorial Trigger A signal  
                     0 = Disabled



# dsPIC33CK256MP508 FAMILY

**REGISTER 12-8: CMBTRIGH: COMBINATIONAL TRIGGER REGISTER HIGH**

U-0	U-0	U-0	U-0	U-0	U-0	U-0	U-0
—	—	—	—	—	—	—	—
bit 15							bit 8

R/W-0	R/W-0	R/W-0	R/W-0	R/W-0	R/W-0	R/W-0	R/W-0
CTB8EN	CTB7EN	CTB6EN	CTB5EN	CTB4EN	CTB3EN	CTB2EN	CTB1EN
bit 7							bit 0

<b>Legend:</b>			
R = Readable bit	W = Writable bit	U = Unimplemented bit, read as '0'	
-n = Value at POR	'1' = Bit is set	'0' = Bit is cleared	x = Bit is unknown

- bit 15-8      **Unimplemented:** Read as '0'
- bit 7        **CTB8EN:** Enable Trigger Output from PWM Generator #8 as Source for Combinational Trigger B bit  
                  1 = Enables specified trigger signal to be OR'd into the Combinatorial Trigger B signal  
                  0 = Disabled
- bit 6        **CTB7EN:** Enable Trigger Output from PWM Generator #7 as Source for Combinational Trigger B bit  
                  1 = Enables specified trigger signal to be OR'd into the Combinatorial Trigger B signal  
                  0 = Disabled
- bit 5        **CTB6EN:** Enable Trigger Output from PWM Generator #6 as Source for Combinational Trigger B bit  
                  1 = Enables specified trigger signal to be OR'd into the Combinatorial Trigger B signal  
                  0 = Disabled
- bit 4        **CTB5EN:** Enable Trigger Output from PWM Generator #5 as Source for Combinational Trigger B bit  
                  1 = Enables specified trigger signal to be OR'd into the Combinatorial Trigger B signal  
                  0 = Disabled
- bit 3        **CTB4EN:** Enable Trigger Output from PWM Generator #4 as Source for Combinational Trigger B bit  
                  1 = Enables specified trigger signal to be OR'd into the Combinatorial Trigger B signal  
                  0 = Disabled
- bit 2        **CTB3EN:** Enable Trigger Output from PWM Generator #3 as Source for Combinational Trigger B bit  
                  1 = Enables specified trigger signal to be OR'd into the Combinatorial Trigger B signal  
                  0 = Disabled
- bit 1        **CTB2EN:** Enable Trigger Output from PWM Generator #2 as Source for Combinational Trigger B bit  
                  1 = Enables specified trigger signal to be OR'd into the Combinatorial Trigger B signal  
                  0 = Disabled
- bit 0        **CTB1EN:** Enable Trigger Output from PWM Generator #1 as Source for Combinational Trigger B bit  
                  1 = Enables specified trigger signal to be OR'd into the Combinatorial Trigger B signal  
                  0 = Disabled

# dsPIC33CK256MP508 FAMILY

## REGISTER 12-9: LOGCONy: COMBINATORIAL PWM LOGIC CONTROL REGISTER y<sup>(2)</sup>

R/W-0	R/W-0	R/W-0	R/W-0	R/W-0	R/W-0	R/W-0	R/W-0
PWMS1y3 <sup>(1)</sup>	PWMS1y2 <sup>(1)</sup>	PWMS1y1 <sup>(1)</sup>	PWMS1y0 <sup>(1)</sup>	PWMS2y3 <sup>(1)</sup>	PWMS2y2 <sup>(1)</sup>	PWMS2y1 <sup>(1)</sup>	PWMS2y0 <sup>(1)</sup>
bit 15							bit 8

R/W-0	R/W-0	R/W-0	R/W-0	U-0	R/W-0	R/W-0	R/W-0
S1yPOL	S2yPOL	PWMLFy1	PWMLFy0	—	PWMLFyD2 <sup>(3)</sup>	PWMLFyD1 <sup>(3)</sup>	PWMLFyD0 <sup>(3)</sup>
bit 7							bit 0

### Legend:

R = Readable bit                      W = Writable bit                      U = Unimplemented bit, read as '0'  
 -n = Value at POR                      '1' = Bit is set                      '0' = Bit is cleared                      x = Bit is unknown

bit 15-12      **PWMS1y[3:0]:** Combinatorial PWM Logic Source #1 Selection bits<sup>(1)</sup>

1111 = PWM8L  
 1110 = PWM8H  
 1101 = PWM7L  
 1100 = PWM7H  
 1011 = PWM6L  
 1010 = PWM6H  
 1001 = PWM5L  
 1000 = PWM5H  
 0111 = PWM4L  
 0110 = PWM4H  
 0101 = PWM3L  
 0100 = PWM3H  
 0011 = PWM2L  
 0010 = PWM2H  
 0001 = PWM1L  
 0000 = PWM1H

bit 11-8      **PWMS2y[3:0]:** Combinatorial PWM Logic Source #2 Selection bits<sup>(1)</sup>

1111 = PWM8L  
 1110 = PWM8H  
 1101 = PWM7L  
 1100 = PWM7H  
 1011 = PWM6L  
 1010 = PWM6H  
 1001 = PWM5L  
 1000 = PWM5H  
 0111 = PWM4L  
 0110 = PWM4H  
 0101 = PWM3L  
 0100 = PWM3H  
 0011 = PWM2L  
 0010 = PWM2H  
 0001 = PWM1L  
 0000 = PWM1H

- Note 1:** Logic function input will be connected to '0' if the PWM channel is not present.  
**Note 2:** 'y' denotes a common instance (A-F).  
**Note 3:** Instances of y = A, C, E of LOGCONy assign logic function output to the PWMxH pin. Instances of y = B, D, F of LOGCONy assign logic function to the PWMxL pin.

# dsPIC33CK256MP508 FAMILY

---

---

## REGISTER 12-9: LOGCONy: COMBINATORIAL PWM LOGIC CONTROL REGISTER y<sup>(2)</sup> (CONTINUED)

bit 7	<b>S1yPOL:</b> Combinatorial PWM Logic Source #1 Polarity bit 1 = Input is inverted 0 = Input is positive logic
bit 6	<b>S2yPOL:</b> Combinatorial PWM Logic Source #2 Polarity bit 1 = Input is inverted 0 = Input is positive logic
bit 5-4	<b>PWMLFy[1:0]:</b> Combinatorial PWM Logic Function Selection bits 11 = Reserved 10 = PWMS1y ^ PWMS2y (XOR) 01 = PWMS1y & PWMS2y (AND) 00 = PWMS1y   PWMS2y (OR)
bit 3	<b>Unimplemented:</b> Read as '0'
bit 2-0	<b>PWMLFyD[2:0]:</b> Combinatorial PWM Logic Destination Selection bits <sup>(3)</sup> 111 = Logic function is assigned to PWM8H or PWM8L pin 110 = Logic function is assigned to PWM7H or PWM7L pin 101 = Logic function is assigned to PWM6H or PWM6L pin 100 = Logic function is assigned to PWM5H or PWM5L pin 011 = Logic function is assigned to PWM4H or PWM4L pin 010 = Logic function is assigned to PWM3H or PWM3L pin 001 = Logic function is assigned to PWM2H or PWM2L pin 000 = No assignment, combinatorial PWM logic function is disabled

**Note 1:** Logic function input will be connected to '0' if the PWM channel is not present.

**2:** 'y' denotes a common instance (A-F).

**3:** Instances of y = A, C, E of LOGCONy assign logic function output to the PWMxH pin. Instances of y = B, D, F of LOGCONy assign logic function to the PWMxL pin.

# dsPIC33CK256MP508 FAMILY

## REGISTER 12-10: PWMEV<sub>Ty</sub>: PWM EVENT OUTPUT CONTROL REGISTER <sub>y</sub><sup>(5)</sup>

R/W-0	R/W-0	R/W-0	R/W-0	U-0	U-0	U-0	U-0
EVTyOEN	EVTyPOL	EVTySTRD	EVTySYNC	—	—	—	—
bit 15							bit 8

R/W-0	R/W-0	R/W-0	R/W-0	U-0	R/W-0	R/W-0	R/W-0
EVTySEL3	EVTySEL2	EVTySEL1	EVTySEL0	—	EVTyPGS2 <sup>(2)</sup>	EVTyPGS1 <sup>(2)</sup>	EVTyPGS0 <sup>(2)</sup>
bit 7							bit 0

### Legend:

R = Readable bit

W = Writable bit

U = Unimplemented bit, read as '0'

-n = Value at POR

'1' = Bit is set

'0' = Bit is cleared

x = Bit is unknown

- bit 15      **EVTyOEN:** PWM Event Output Enable bit  
 1 = Event output signal is output on PWME<sub>y</sub> pin  
 0 = Event output signal is internal only
- bit 14      **EVTyPOL:** PWM Event Output Polarity bit  
 1 = Event output signal is active-low  
 0 = Event output signal is active-high
- bit 13      **EVTySTRD:** PWM Event Output Stretch Disable bit  
 1 = Event output signal pulse width is not stretched  
 0 = Event output signal is stretched to eight PWM clock cycles minimum<sup>(1)</sup>
- bit 12      **EVTySYNC:** PWM Event Output Sync bit  
 1 = Event output signal is synchronized to the system clock  
 0 = Event output is not synchronized to the system clock  
 Event output signal pulse will be two system clocks when this bit is set and EVTySTRD = 1.
- bit 11-8    **Unimplemented:** Read as '0'
- bit 7-4      **EVTySEL[3:0]:** PWM Event Selection bits  
 1111 = High-resolution error event signal  
 1110-1010 = Reserved  
 1001 = ADC Trigger 2 signal  
 1000 = ADC Trigger 1 signal  
 0111 = STEER signal (available in Push-Pull Output modes only)<sup>(4)</sup>  
 0110 = CAHALF signal (available in Center-Aligned modes only)<sup>(4)</sup>  
 0101 = PCI Fault active output signal  
 0100 = PCI current-limit active output signal  
 0011 = PCI feed-forward active output signal  
 0010 = PCI Sync active output signal  
 0001 = PWM Generator output signal<sup>(3)</sup>  
 0000 = Source is selected by the PGTRGSEL[2:0] bits
- bit 3        **Unimplemented:** Read as '0'

**Note 1:** The event signal is stretched using peripheral\_clk because different PWM Generators may be operating from different clock sources.

**2:** No event will be produced if the selected PWM Generator is not present.

**3:** This is the PWM Generator output signal prior to output mode logic and any output override logic.

**4:** This signal should be the PG<sub>x</sub>\_clk domain signal prior to any synchronization into the system clock domain.

**5:** 'y' denotes a common instance (A-F).

# dsPIC33CK256MP508 FAMILY

---

## REGISTER 12-10: PWMEVT<sub>y</sub>: PWM EVENT OUTPUT CONTROL REGISTER <sub>y</sub><sup>(5)</sup> (CONTINUED)

bit 2-0      **EVT<sub>y</sub>PGS[2:0]**: PWM Event Source Selection bits<sup>(2)</sup>  
              111 = PWM Generator 8  
              110 = PWM Generator 7  
              . . .  
              000 = PWM Generator 1

- Note 1:** The event signal is stretched using peripheral\_clk because different PWM Generators may be operating from different clock sources.
- 2:** No event will be produced if the selected PWM Generator is not present.
- 3:** This is the PWM Generator output signal prior to output mode logic and any output override logic.
- 4:** This signal should be the PG<sub>x</sub>\_clk domain signal prior to any synchronization into the system clock domain.
- 5:** 'y' denotes a common instance (A-F).

# dsPIC33CK256MP508 FAMILY

## REGISTER 12-11: LFSR: LINEAR FEEDBACK SHIFT REGISTER

U-0	R/W-0	R/W-0	R/W-0	R/W-0	R/W-0	R/W-0	R/W-0	
—	LFSR[14:8]							
bit 15								bit 8

R/W-0	R/W-0	R/W-0	R/W-0	R/W-0	R/W-0	R/W-0	R/W-0
LFSR[7:0]							
bit 7							bit 0

### Legend:

R = Readable bit                      W = Writable bit                      U = Unimplemented bit, read as '0'  
 -n = Value at POR                      '1' = Bit is set                      '0' = Bit is cleared                      x = Bit is unknown

bit 15                      **Unimplemented:** Read as '0'

bit 14-0                      **LFSR[14:0]:** Linear Feedback Shift Register bits

A read of this register will provide a 15-bit pseudorandom value.

# dsPIC33CK256MP508 FAMILY

## REGISTER 12-12: PGxCONL: PWM GENERATOR x CONTROL REGISTER LOW

R/W-0	r-0	U-0	U-0	U-0	R/W-0	R/W-0	R/W-0
ON	—	—	—	—	TRGCNT2	TRGCNT1	TRGCNT0
bit 15						bit 8	

R/W-0	U-0	U-0	R/W-0	R/W-0	R/W-0	R/W-0	R/W-0
HREN	—	—	CLKSEL1	CLKSEL0	MODSEL2	MODSEL1	MODSEL0
bit 7						bit 0	

<b>Legend:</b>	r = Reserved bit	W = Writable bit	U = Unimplemented bit, read as '0'
R = Readable bit		'1' = Bit is set	'0' = Bit is cleared
-n = Value at POR			x = Bit is unknown

- bit 15      **ON:** Enable bit  
                  1 = PWM Generator is enabled  
                  0 = PWM Generator is not enabled
- bit 14      **Reserved:** Maintain as '0'
- bit 13-11   **Unimplemented:** Read as '0'
- bit 10-8    **TRGCNT[2:0]:** Trigger Count Select bits  
                  111 = PWM Generator produces eight PWM cycles after triggered  
                  110 = PWM Generator produces seven PWM cycles after triggered  
                  101 = PWM Generator produces six PWM cycles after triggered  
                  100 = PWM Generator produces five PWM cycles after triggered  
                  011 = PWM Generator produces four PWM cycles after triggered  
                  010 = PWM Generator produces three PWM cycles after triggered  
                  001 = PWM Generator produces two PWM cycles after triggered  
                  000 = PWM Generator produces one PWM cycle after triggered
- bit 7        **HREN:** PWM Generator x High-Resolution Enable bit  
                  1 = PWM Generator x operates in High-Resolution mode<sup>(2)</sup>  
                  0 = PWM Generator x operates in standard resolution
- bit 6-5     **Unimplemented:** Read as '0'
- bit 4-3     **CLKSEL[1:0]:** Clock Selection bits  
                  11 = PWM Generator uses Master clock scaled by frequency scaling circuit<sup>(1)</sup>  
                  10 = PWM Generator uses Master clock divided by clock divider circuit<sup>(1)</sup>  
                  01 = PWM Generator uses Master clock selected by the MCLKSEL[1:0] (PCLKCON[1:0]) control bits  
                  00 = No clock selected, PWM Generator is in lowest power state (default)
- bit 2-0     **MODSEL[2:0]:** Mode Selection bits  
                  111 = Dual Edge Center-Aligned PWM mode (interrupt/register update twice per cycle)  
                  110 = Dual Edge Center-Aligned PWM mode (interrupt/register update once per cycle)  
                  101 = Double-Update Center-Aligned PWM mode  
                  100 = Center-Aligned PWM mode  
                  011 = Reserved  
                  010 = Independent Edge PWM mode, dual output  
                  001 = Variable Phase PWM mode  
                  000 = Independent Edge PWM mode

- Note 1:** The PWM Generator time base operates from the frequency scaling circuit clock, effectively scaling the duty cycle and period of the PWM Generator output.
- 2:** Input frequency of 500 MHz must be used for High-Resolution mode.

# dsPIC33CK256MP508 FAMILY

## REGISTER 12-13: PGxCONH: PWM GENERATOR x CONTROL REGISTER HIGH

R/W-0	R/W-0	R/W-0	U-0	R/W-0	R/W-0	R/W-0	R/W-0
MDCSEL	MPERSEL	MPHSEL	—	MSTEN	UPDMOD2	UPDMOD1	UPDMOD0
bit 15							bit 8

r-0	R/W-0	U-0	U-0	R/W-0	R/W-0	R/W-0	R/W-0
—	TRGMOD	—	—	SOCS3 <sup>(1,2,3)</sup>	SOCS2 <sup>(1,2,3)</sup>	SOCS1 <sup>(1,2,3)</sup>	SOCS0 <sup>(1,2,3)</sup>
bit 7							bit 0

<b>Legend:</b>	r = Reserved bit		
R = Readable bit	W = Writable bit	U = Unimplemented bit, read as '0'	
-n = Value at POR	'1' = Bit is set	'0' = Bit is cleared	x = Bit is unknown

- bit 15      **MDCSEL:** Master Duty Cycle Register Select bit  
 1 = PWM Generator uses MDC register  
 0 = PWM Generator uses PGxDC register
- bit 14      **MPERSEL:** Master Period Register Select bit  
 1 = PWM Generator uses MPER register  
 0 = PWM Generator uses PGxPER register
- bit 13      **MPHSEL:** Master Phase Register Select bit  
 1 = PWM Generator uses MPHASE register  
 0 = PWM Generator uses PGxPHASE register
- bit 12      **Unimplemented:** Read as '0'
- bit 11      **MSTEN:** Host Update Enable bit  
 1 = PWM Generator broadcasts software set/clear of the UPDREQ status bit and EOC signal to other PWM Generators  
 0 = PWM Generator does not broadcast the UPDREQ status bit state or EOC signal
- bit 10-8    **UPDMOD[2:0]:** PWM Buffer Update Mode Selection bits  
 011 = Client immediate update  
 Update data registers immediately, or as soon as possible, when a Host update request is received. A Host update request will be transmitted if MSTEN = 1 and UPDREQ = 1 for the requesting PWM Generator.
- 010 = Client SOC update  
 Update data registers at start of next cycle if a Host update request is received. A Host update request will be transmitted if MSTEN = 1 and UPDREQ = 1 for the requesting PWM Generator.
- 001 = Immediate update  
 Data registers immediately, or as soon as possible, if UPDREQ = 1. The UPDATE status bit will be cleared automatically after the update occurs.
- 000 = SOC update  
 Data registers at start of next PWM cycle if UPDREQ = 1. The UPDATE status bit will be cleared automatically after the update occurs<sup>(1)</sup>
- bit 7      **Reserved:** Maintain as '0'

- Note 1:** The PCI selected Sync signal is always available to be OR'd with the selected SOC signal per the SOCS[3:0] bits if the PCI Sync function is enabled.
- 2:** The source selected by the SOCS[3:0] bits MUST operate from the same clock source as the local PWM Generator. If not, the source must be routed through the PCI Sync logic so the trigger signal may be synchronized to the PWM Generator clock domain.
- 3:** PWM Generators are grouped into groups of four: PG1-PG4 and PG5-PG8, if available. Any generator within a group of four may be used to trigger another generator within the same group.



# dsPIC33CK256MP508 FAMILY

---

## REGISTER 12-13: PGxCONH: PWM GENERATOR x CONTROL REGISTER HIGH (CONTINUED)

bit 6	<b>TRGMOD:</b> PWM Generator Trigger Mode Selection bit 1 = PWM Generator operates in Retriggerable mode 0 = PWM Generator operates in Single Trigger mode
bit 5-4	<b>Unimplemented:</b> Read as '0'
bit 3-0	<b>SOCS[3:0]:</b> Start-of-Cycle Selection bits <sup>(1,2,3)</sup> 1111 = TRIG bit or PCI Sync function only (no hardware trigger source is selected) 1110-0101 = Reserved 0100 = Trigger output selected by PG4 or PG8 PGTRGSEL[2:0] bits (PGxEVTL[2:0]) 0011 = Trigger output selected by PG3 or PG7 PGTRGSEL[2:0] bits (PGxEVTL[2:0]) 0010 = Trigger output selected by PG2 or PG6 PGTRGSEL[2:0] bits (PGxEVTL[2:0]) 0001 = Trigger output selected by PG1 or PG5 PGTRGSEL[2:0] bits (PGxEVTL[2:0]) 0000 = Local EOC – PWM Generator is self-triggered

- Note 1:** The PCI selected Sync signal is always available to be OR'd with the selected SOC signal per the SOCS[3:0] bits if the PCI Sync function is enabled.
- 2:** The source selected by the SOCS[3:0] bits MUST operate from the same clock source as the local PWM Generator. If not, the source must be routed through the PCI Sync logic so the trigger signal may be synchronized to the PWM Generator clock domain.
- 3:** PWM Generators are grouped into groups of four: PG1-PG4 and PG5-PG8, if available. Any generator within a group of four may be used to trigger another generator within the same group.

# dsPIC33CK256MP508 FAMILY

## REGISTER 12-14: PGxSTAT: PWM GENERATOR x STATUS REGISTER

HS/C-0	HS/C-0	HS/C-0	HS/C-0	R-0	R-0	R-0	R-0
SEVT	FLTEVT	CLEVT	FFEVT	SACT	FLTACT	CLACT	FFACT
bit 15						bit 8	

W-0	W-0	HS/R-0	R-0	W-0	R-0	R-0	R-0
TRSET	TRCLR	CAP <sup>(1)</sup>	UPDATE	UPDREQ	STEER	CAHALF	TRIG
bit 7						bit 0	

<b>Legend:</b>	C = Clearable bit	HS = Hardware Settable bit
R = Readable bit	W = Writable bit	'0' = Bit is cleared      x = Bit is unknown
-n = Value at POR	'1' = Bit is set	U = Unimplemented bit, read as '0'

- bit 15      **SEVT:** PCI Sync Event bit  
 1 = A PCI Sync event has occurred (rising edge on PCI Sync output or PCI Sync output is high when module is enabled)  
 0 = No PCI Sync event has occurred
- bit 14      **FLTEVT:** PCI Fault Active Status bit  
 1 = A Fault event has occurred (rising edge on PCI Fault output or PCI Fault output is high when module is enabled)  
 0 = No Fault event has occurred
- bit 13      **CLEVT:** PCI Current-Limit Status bit  
 1 = A PCI current-limit event has occurred (rising edge on PCI current-limit output or PCI current-limit output is high when module is enabled)  
 0 = No PCI current-limit event has occurred
- bit 12      **FFEVT:** PCI Feed-Forward Active Status bit  
 1 = A PCI feed-forward event has occurred (rising edge on PCI feed-forward output or PCI feed-forward output is high when module is enabled)  
 0 = No PCI feed-forward event has occurred
- bit 11      **SACT:** PCI Sync Status bit  
 1 = PCI Sync output is active  
 0 = PCI Sync output is inactive
- bit 10      **FLTACT:** PCI Fault Active Status bit  
 1 = PCI Fault output is active  
 0 = PCI Fault output is inactive
- bit 9        **CLACT:** PCI Current-Limit Status bit  
 1 = PCI current-limit output is active  
 0 = PCI current-limit output is inactive
- bit 8        **FFACT:** PCI Feed-Forward Active Status bit  
 1 = PCI feed-forward output is active  
 0 = PCI feed-forward output is inactive
- bit 7        **TRSET:** PWM Generator Software Trigger Set bit  
 User software writes a '1' to this bit location to trigger a PWM Generator cycle. The bit location always reads as '0'. The TRIG bit will indicate '1' when the PWM Generator is triggered.
- bit 6        **TRCLR:** PWM Generator Software Trigger Clear bit  
 User software writes a '1' to this bit location to stop a PWM Generator cycle. The bit location always reads as '0'. The TRIG bit will indicate '0' when the PWM Generator is not triggered.

**Note 1:** The CAP status bit will be set when the capture event has occurred. No further captures will occur until CAP is cleared by software.

# dsPIC33CK256MP508 FAMILY

---

## REGISTER 12-14: PGxSTAT: PWM GENERATOR x STATUS REGISTER (CONTINUED)

- bit 5      **CAP:** Capture Status bit<sup>(1)</sup>  
1 = PWM Generator time base value has been captured in PGxCAP  
0 = No capture has occurred
- bit 4      **UPDATE:** PWM Data Register Update Status bit  
1 = PWM Data register update is pending – user Data registers are not writable  
0 = No PWM Data register update is pending
- bit 3      **UPDREQ:** PWM Data Register Update Request bit  
User software writes a '1' to this bit location to request a PWM Data register update. The bit location always reads as '0'. The UPDATE status bit will indicate '1' when an update is pending.
- bit 2      **STEER:** Output Steering Status bit (Push-Pull Output mode only)  
1 = PWM Generator is in 2nd cycle of Push-Pull mode  
0 = PWM Generator is in 1st cycle of Push-Pull mode
- bit 1      **CAHALF:** Half Cycle Status bit (Center-Aligned modes only)  
1 = PWM Generator is in 2nd half of time base cycle  
0 = PWM Generator is in 1st half of time base cycle
- bit 0      **TRIG:** PWM Trigger Status bit  
1 = PWM Generator is triggered and PWM cycle is in progress  
0 = No PWM cycle is in progress

**Note 1:** The CAP status bit will be set when the capture event has occurred. No further captures will occur until CAP is cleared by software.

# dsPIC33CK256MP508 FAMILY

## REGISTER 12-15: PGxIOCONL: PWM GENERATOR x I/O CONTROL REGISTER LOW

R/W-0	R/W-0	R/W-0	R/W-0	R/W-0	R/W-0	R/W-0	R/W-0
CLMOD	SWAP	OVRENH	OVRENL	OVRDAT1	OVRDAT0	OSYNC1	OSYNC0
bit 15						bit 8	

R/W-0	R/W-0	R/W-0	R/W-0	R/W-0	R/W-0	R/W-0	R/W-0
FLTDAT1	FLTDAT0	CLDAT1	CLDAT0	FFDAT1	FFDAT0	DBDAT1	DBDAT0
bit 7						bit 0	

### Legend:

R = Readable bit      W = Writable bit      U = Unimplemented bit, read as '0'  
 -n = Value at POR      '1' = Bit is set      '0' = Bit is cleared      x = Bit is unknown

- bit 15      **CLMOD:** Current-Limit Mode Select bit  
 1 = If PCI current limit is active, then the PWMxH and PWMxL output signals are inverted (bit flipping), and the CLDAT[1:0] bits are not used  
 0 = If PCI current limit is active, then the CLDAT[1:0] bits define the PWM output levels
- bit 14      **SWAP:** Swap PWM Signals to PWMxH and PWMxL Device Pins bit  
 1 = The PWMxH signal is connected to the PWMxL pin and the PWMxL signal is connected to the PWMxH pin  
 0 = PWMxH/L signals are mapped to their respective pins
- bit 13      **OVRENH:** User Override Enable for PWMxH Pin bit  
 1 = OVRDAT1 provides data for output on the PWMxH pin  
 0 = PWM Generator provides data for the PWMxH pin
- bit 12      **OVRENL:** User Override Enable for PWMxL Pin bit  
 1 = OVRDAT0 provides data for output on the PWMxL pin  
 0 = PWM Generator provides data for the PWMxL pin
- bit 11-10      **OVRDAT[1:0]:** Data for PWMxH/PWMxL Pins if Override is Enabled bits  
 If OVERENH = 1, then OVRDAT1 provides data for PWMxH.  
 If OVERENL = 1, then OVRDAT0 provides data for PWMxL.
- bit 9-8      **OSYNC[1:0]:** User Output Override Synchronization Control bits  
 11 = Reserved  
 10 = User output overrides via the OVRENH/L and OVRDAT[1:0] bits occur when specified by the UPDMOD[2:0] bits in the PGxCONH register  
 01 = User output overrides via the OVRENH/L and OVRDAT[1:0] bits occur immediately (as soon as possible)  
 00 = User output overrides via the OVRENH/L and OVRDAT[1:0] bits are synchronized to the local PWM time base (next Start-of-Cycle)
- bit 7-6      **FLTDAT[1:0]:** Data for PWMxH/PWMxL Pins if Fault Event is Active bits  
 If Fault is active, then FLTDAT1 provides data for PWMxH.  
 If Fault is active, then FLTDAT0 provides data for PWMxL.
- bit 5-4      **CLDAT[1:0]:** Data for PWMxH/PWMxL Pins if Current-Limit Event is Active bits  
 If current limit is active, then CLDAT1 provides data for PWMxH.  
 If current limit is active, then CLDAT0 provides data for PWMxL.
- bit 3-2      **FFDAT[1:0]:** Data for PWMxH/PWMxL Pins if Feed-Forward Event is Active bits  
 If feed-forward is active, then FFDAT1 provides data for PWMxH.  
 If feed-forward is active, then FFDAT0 provides data for PWMxL.
- bit 1-0      **DBDAT[1:0]:** Data for PWMxH/PWMxL Pins if Debug Mode is Active bits  
 If Debug mode is active and device halted, then DBDAT1 provides data for PWMxH.  
 If Debug mode is active and device halted, then DBDAT0 provides data for PWMxL.

# dsPIC33CK256MP508 FAMILY

## REGISTER 12-16: PGxIOCONH: PWM GENERATOR x I/O CONTROL REGISTER HIGH

U-0	R/W-0	R/W-0	R/W-0	U-0	U-0	U-0	R/W-0
—	CAPSRC2 <sup>(1)</sup>	CAPSRC1 <sup>(1)</sup>	CAPSRC0 <sup>(1)</sup>	—	—	—	DTCMPSEL
bit 15							bit 8

U-0	U-0	R/W-0	R/W-0	R/W-0	R/W-0	R/W-0	R/W-0
—	—	PMOD1	PMOD0	PENH	PENL	POLH	POLL
bit 7							bit 0

### Legend:

R = Readable bit      W = Writable bit      U = Unimplemented bit, read as '0'  
 -n = Value at POR      '1' = Bit is set      '0' = Bit is cleared      x = Bit is unknown

- bit 15      **Unimplemented:** Read as '0'
- bit 14-12      **CAPSRC[2:0]:** Time Base Capture Source Selection bits<sup>(1)</sup>  
 111 = Reserved  
 110 = Reserved  
 101 = Reserved  
 100 = Capture time base value at assertion of selected PCI Fault signal  
 011 = Capture time base value at assertion of selected PCI current-limit signal  
 010 = Capture time base value at assertion of selected PCI feed-forward signal  
 001 = Capture time base value at assertion of selected PCI Sync signal  
 000 = No hardware source selected for time base capture – software only
- bit 11-9      **Unimplemented:** Read as '0'
- bit 8      **DTCMPSEL:** Dead-Time Compensation Select bit  
 1 = Dead-time compensation is controlled by PCI feed-forward limit logic  
 0 = Dead-time compensation is controlled by PCI Sync logic
- bit 7-6      **Unimplemented:** Read as '0'
- bit 5-4      **PMOD[1:0]:** PWM Generator Output Mode Selection bits  
 11 = Reserved  
 10 = PWM Generator outputs operate in Push-Pull mode  
 01 = PWM Generator outputs operate in Independent mode  
 00 = PWM Generator outputs operate in Complementary mode
- bit 3      **PENH:** PWMxH Output Port Enable bit  
 1 = PWM Generator controls the PWMxH output pin  
 0 = PWM Generator does not control the PWMxH output pin
- bit 2      **PENL:** PWMxL Output Port Enable bit  
 1 = PWM Generator controls the PWMxL output pin  
 0 = PWM Generator does not control the PWMxL output pin
- bit 1      **POLH:** PWMxH Output Polarity bit  
 1 = Output pin is active-low  
 0 = Output pin is active-high
- bit 0      **POLL:** PWMxL Output Polarity bit  
 1 = Output pin is active-low  
 0 = Output pin is active-high

**Note 1:** A capture may be initiated in software at any time by writing a '1' to PGxCAP[0].

# dsPIC33CK256MP508 FAMILY

## REGISTER 12-17: PGxEVTL: PWM GENERATOR x EVENT REGISTER LOW

R/W-0	R/W-0	R/W-0	R/W-0	R/W-0	R/W-0	R/W-0	R/W-0
ADTR1PS4	ADTR1PS3	ADTR1PS2	ADTR1PS1	ADTR1PS0	ADTR1EN3	ADTR1EN2	ADTR1EN1
bit 15							bit 8

U-0	U-0	U-0	R/W-0	R/W-0	R/W-0	R/W-0	R/W-0
—	—	—	UPDTRG1	UPDTRG0	PGTRGSEL2 <sup>(1)</sup>	PGTRGSEL1 <sup>(1)</sup>	PGTRGSEL0 <sup>(1)</sup>
bit 7							bit 0

### Legend:

R = Readable bit      W = Writable bit      U = Unimplemented bit, read as '0'  
 -n = Value at POR      '1' = Bit is set      '0' = Bit is cleared      x = Bit is unknown

bit 15-11 **ADTR1PS[4:0]:** ADC Trigger 1 Postscaler Selection bits

11111 = 1:32

...

00010 = 1:3

00001 = 1:2

00000 = 1:1

bit 10 **ADTR1EN3:** ADC Trigger 1 Source is PGxTRIGC Compare Event Enable bit

1 = PGxTRIGC register compare event is enabled as trigger source for ADC Trigger 1

0 = PGxTRIGC register compare event is disabled as trigger source for ADC Trigger 1

bit 9 **ADTR1EN2:** ADC Trigger 1 Source is PGxTRIGB Compare Event Enable bit

1 = PGxTRIGB register compare event is enabled as trigger source for ADC Trigger 1

0 = PGxTRIGB register compare event is disabled as trigger source for ADC Trigger 1

bit 8 **ADTR1EN1:** ADC Trigger 1 Source is PGxTRIGA Compare Event Enable bit

1 = PGxTRIGA register compare event is enabled as trigger source for ADC Trigger 1

0 = PGxTRIGA register compare event is disabled as trigger source for ADC Trigger 1

bit 7-5 **Unimplemented:** Read as '0'

bit 4-3 **UPDTRG[1:0]:** Update Trigger Select bits

11 = A write of the PGxTRIGA register automatically sets the UPDATE bit

10 = A write of the PGxPHASE register automatically sets the UPDATE bit

01 = A write of the PGxDC register automatically sets the UPDATE bit

00 = User must set the UPDREQ bit (PGxSTAT[3]) manually

bit 2-0 **PGTRGSEL[2:0]:** PWM Generator Trigger Output Selection bits<sup>(1)</sup>

111 = Reserved

110 = Reserved

101 = Reserved

100 = Reserved

011 = PGxTRIGC compare event is the PWM Generator trigger

010 = PGxTRIGB compare event is the PWM Generator trigger

001 = PGxTRIGA compare event is the PWM Generator trigger

000 = EOC event is the PWM Generator trigger

**Note 1:** These events are derived from the internal PWM Generator time base comparison events.

# dsPIC33CK256MP508 FAMILY

## REGISTER 12-18: PGxEVTH: PWM GENERATOR x EVENT REGISTER HIGH

R/W-0	R/W-0	R/W-0	R/W-0	U-0	U-0	R/W-0	R/W-0
FLTIE <sup>(1)</sup>	CLIE <sup>(2)</sup>	FFIE <sup>(3)</sup>	SIEN <sup>(4)</sup>	—	—	IEVTSEL1	IEVTSEL0
bit 15						bit 8	

R/W-0	R/W-0	R/W-0	R/W-0	R/W-0	R/W-0	R/W-0	R/W-0
ADTR2EN3	ADTR2EN2	ADTR2EN1	ADTR1OFS4	ADTR1OFS3	ADTR1OFS2	ADTR1OFS1	ADTR1OFS0
bit 7						bit 0	

### Legend:

R = Readable bit	W = Writable bit	U = Unimplemented bit, read as '0'
-n = Value at POR	'1' = Bit is set	'0' = Bit is cleared
		x = Bit is unknown

- bit 15      **FLTIE**: PCI Fault Interrupt Enable bit<sup>(1)</sup>  
 1 = Fault interrupt is enabled  
 0 = Fault interrupt is disabled
- bit 14      **CLIE**: PCI Current-Limit Interrupt Enable bit<sup>(2)</sup>  
 1 = Current-limit interrupt is enabled  
 0 = Current-limit interrupt is disabled
- bit 13      **FFIE**: PCI Feed-Forward Interrupt Enable bit<sup>(3)</sup>  
 1 = Feed-forward interrupt is enabled  
 0 = Feed-forward interrupt is disabled
- bit 12      **SIEN**: PCI Sync Interrupt Enable bit<sup>(4)</sup>  
 1 = Sync interrupt is enabled  
 0 = Sync interrupt is disabled
- bit 11-10   **Unimplemented**: Read as '0'
- bit 9-8      **IEVTSEL[1:0]**: Interrupt Event Selection bits  
 11 = Time base interrupts are disabled (Sync, Fault, current-limit and feed-forward events can be independently enabled)  
 10 = Interrupts CPU at ADC Trigger 1 event  
 01 = Interrupts CPU at TRIGA compare event  
 00 = Interrupts CPU at EOC
- bit 7      **ADTR2EN3**: ADC Trigger 2 Source is PGxTRIGC Compare Event Enable bit  
 1 = PGxTRIGC register compare event is enabled as trigger source for ADC Trigger 2  
 0 = PGxTRIGC register compare event is disabled as trigger source for ADC Trigger 2
- bit 6      **ADTR2EN2**: ADC Trigger 2 Source is PGxTRIGB Compare Event Enable bit  
 1 = PGxTRIGB register compare event is enabled as trigger source for ADC Trigger 2  
 0 = PGxTRIGB register compare event is disabled as trigger source for ADC Trigger 2
- bit 5      **ADTR2EN1**: ADC Trigger 2 Source is PGxTRIGA Compare Event Enable bit  
 1 = PGxTRIGA register compare event is enabled as trigger source for ADC Trigger 2  
 0 = PGxTRIGA register compare event is disabled as trigger source for ADC Trigger 2

- Note 1:** An interrupt is only generated on the rising edge of the PCI Fault active signal.  
**2:** An interrupt is only generated on the rising edge of the PCI current-limit active signal.  
**3:** An interrupt is only generated on the rising edge of the PCI feed-forward active signal.  
**4:** An interrupt is only generated on the rising edge of the PCI Sync active signal.

# dsPIC33CK256MP508 FAMILY

---

## REGISTER 12-18: PGxEVTH: PWM GENERATOR x EVENT REGISTER HIGH (CONTINUED)

bit 4-0      **ADTR1OFS[4:0]**: ADC Trigger 1 Offset Selection bits

11111 = Offset by 31 trigger events

...

00010 = Offset by 2 trigger events

00001 = Offset by 1 trigger event

00000 = No offset

- Note 1:** An interrupt is only generated on the rising edge of the PCI Fault active signal.
- 2:** An interrupt is only generated on the rising edge of the PCI current-limit active signal.
- 3:** An interrupt is only generated on the rising edge of the PCI feed-forward active signal.
- 4:** An interrupt is only generated on the rising edge of the PCI Sync active signal.



# dsPIC33CK256MP508 FAMILY

## REGISTER 12-19: PGxyPCIL: PWM GENERATOR xy PCI REGISTER LOW (x = PWM GENERATOR #; y = F, CL, FF OR S)

R/W-0	R/W-0	R/W-0	R/W-0	R/W-0	R/W-0	R/W-0	R/W-0
TSYNCDIS	TERM2	TERM1	TERM0	AQPS	AQSS2	AQSS1	AQSS0
bit 15							bit 8

R/W-0	R/W-0	R/W-0	R/W-0	R/W-0	R/W-0	R/W-0	R/W-0
SWTERM	PSYNC	PPS	PSS4	PSS3	PSS2	PSS1	PSS0
bit 7							bit 0

### Legend:

R = Readable bit                      W = Writable bit                      U = Unimplemented bit, read as '0'  
-n = Value at POR                      '1' = Bit is set                      '0' = Bit is cleared                      x = Bit is unknown

- bit 15        **TSYNCDIS:** Termination Synchronization Disable bit  
1 = Termination of latched PCI occurs immediately  
0 = Termination of latched PCI occurs at PWM EOC
- bit 14-12    **TERM[2:0]:** Termination Event Selection bits  
111 = Selects PCI Source #9  
110 = Selects PCI Source #8  
101 = Selects PCI Source #1 (PWM Generator output selected by the PWMPCI[2:0] bits)  
100 = PGxTRIGC trigger event  
011 = PGxTRIGB trigger event  
010 = PGxTRIGA trigger event  
001 = Auto-Terminate: Terminate when PCI source transitions from active to inactive  
000 = Manual Terminate: Terminate on a write of '1' to the SWTERM bit location
- bit 11        **AQPS:** Acceptance Qualifier Polarity Select bit  
1 = Inverted  
0 = Not inverted
- bit 10-8     **AQSS[2:0]:** Acceptance Qualifier Source Selection bits  
111 = SWPCI control bit only (qualifier forced to '0')  
110 = Selects PCI Source #9  
101 = Selects PCI Source #8  
100 = Selects PCI Source #1 (PWM Generator output selected by the PWMPCI[2:0] bits)  
011 = PWM Generator is triggered  
010 = LEB is active  
001 = Duty cycle is active (base PWM Generator signal)  
000 = No acceptance qualifier is used (qualifier forced to '1')
- bit 7        **SWTERM:** PCI Software Termination bit  
A write of '1' to this location will produce a termination event. This bit location always reads as '0'.
- bit 6        **PSYNC:** PCI Synchronization Control bit  
1 = PCI source is synchronized to PWM EOC  
0 = PCI source is not synchronized to PWM EOC
- bit 5        **PPS:** PCI Polarity Select bit  
1 = Inverted  
0 = Not inverted

# dsPIC33CK256MP508 FAMILY

---

## REGISTER 12-19: PGxyPCIL: PWM GENERATOR xy PCI REGISTER LOW (x = PWM GENERATOR #; y = F, CL, FF OR S) (CONTINUED)

bit 4-0     **PSS[4:0]:** PCI Source Selection bits

- 11111 = CLC1
- 11110 = Reserved
- 11101 = Comparator 3 output
- 11100 = Comparator 2 output
- 11011 = Comparator 1 output
- 11010 = PWM Event D
- 11001 = PWM Event C
- 11000 = PWM Event B
- 10111 = PWM Event A
- 10110 = Device pin, PCI[22]
- 10101 = Device pin, PCI[21]
- 10100 = Device pin, PCI[20]
- 10011 = Device pin, PCI[19]
- 10010 = RPn input, PCI18R
- 10001 = RPn input, PCI17R
- 10000 = RPn input, PCI16R
- 01111 = RPn input, PCI15R
- 01110 = RPn input, PCI14R
- 01101 = RPn input, PCI13R
- 01100 = RPn input, PCI12R
- 01011 = RPn input, PCI11R
- 01010 = RPn input, PCI10R
- 01001 = RPn input, PCI9R
- 01000 = RPn input, PCI8R
- 00111 = Reserved
- 00110 = Reserved
- 00101 = Reserved
- 00100 = Reserved
- 00011 = Internally connected to Combo Trigger B
- 00010 = Internally connected to Combo Trigger A
- 00001 = Internally connected to the output of PWMPCI[2:0] MUX
- 00000 = Tied to '0'

# dsPIC33CK256MP508 FAMILY

## REGISTER 12-20: PG<sub>xy</sub>PCIH: PWM GENERATOR <sub>xy</sub> PCI REGISTER HIGH (x = PWM GENERATOR #; y = F, CL, FF OR S)

R/W-0	R/W-0	R/W-0	R/W-0	U-0	R/W-0	R/W-0	R/W-0
BPEN	BPSEL2 <sup>(1)</sup>	BPSEL1 <sup>(1)</sup>	BPSEL0 <sup>(1)</sup>	—	ACP2	ACP1	ACP0
bit 15							bit 8

R/W-0	R/W-0	R/W-0	R/W-0	R/W-0	R/W-0	R/W-0	R/W-0
SWPCI	SWPCIM1	SWPCIM0	LATMOD	TQPS	TQSS2	TQSS1	TQSS0
bit 7							bit 0

### Legend:

R = Readable bit	W = Writable bit	U = Unimplemented bit, read as '0'
-n = Value at POR	'1' = Bit is set	'0' = Bit is cleared
		x = Bit is unknown

- bit 15     **BPEN:** PCI Bypass Enable bit  
 1 = PCI function is enabled and local PCI logic is bypassed; PWM Generator will be controlled by PCI function in the PWM Generator selected by the BPSEL[2:0] bits  
 0 = PCI function is not bypassed
- bit 14-12   **BPSEL[2:0]:** PCI Bypass Source Selection bits<sup>(1)</sup>  
 111 = PCI control is sourced from PWM Generator 8 PCI logic when BPEN = 1  
 110 = PCI control is sourced from PWM Generator 7 PCI logic when BPEN = 1  
 101 = PCI control is sourced from PWM Generator 6 PCI logic when BPEN = 1  
 100 = PCI control is sourced from PWM Generator 5 PCI logic when BPEN = 1  
 011 = PCI control is sourced from PWM Generator 4 PCI logic when BPEN = 1  
 010 = PCI control is sourced from PWM Generator 3 PCI logic when BPEN = 1  
 001 = PCI control is sourced from PWM Generator 2 PCI logic when BPEN = 1  
 000 = PCI control is sourced from PWM Generator 1 PCI logic when BPEN = 1
- bit 11     **Unimplemented:** Read as '0'
- bit 10-8   **ACP[2:0]:** PCI Acceptance Criteria Selection bits  
 111 = Reserved  
 110 = Reserved  
 101 = Latched any edge  
 100 = Latched rising edge  
 011 = Latched  
 010 = Any edge  
 001 = Rising edge  
 000 = Level-sensitive
- bit 7     **SWPCI:** Software PCI Control bit  
 1 = Drives a '1' to PCI logic assigned to by the SWPCIM[1:0] control bits  
 0 = Drives a '0' to PCI logic assigned to by the SWPCIM[1:0] control bits
- bit 6-5   **SWPCIM[1:0]:** Software PCI Control Mode bits  
 11 = Reserved  
 10 = SWPCI bit is assigned to termination qualifier logic  
 01 = SWPCI bit is assigned to acceptance qualifier logic  
 00 = SWPCI bit is assigned to PCI acceptance logic
- bit 4     **LATMOD:** PCI SR Latch Mode bit  
 1 = SR latch is Reset-dominant in Latched Acceptance modes  
 0 = SR latch is Set-dominant in Latched Acceptance modes

**Note 1:** Selects '0' if selected PWM Generator is not present.

# dsPIC33CK256MP508 FAMILY

---

## REGISTER 12-20: PGxyPCIH: PWM GENERATOR xy PCI REGISTER HIGH (x = PWM GENERATOR #; y = F, CL, FF OR S) (CONTINUED)

bit 3        **TQPS:** Termination Qualifier Polarity Select bit

1 = Inverted

0 = Not inverted

bit 2-0     **TQSS[2:0]:** Termination Qualifier Source Selection bits

111 = SWPCI control bit only (qualifier forced to '0')

110 = Selects PCI Source #9

101 = Selects PCI Source #8

100 = Selects PCI Source #1 (PWM Generator output selected by the PWMPCI[2:0] bits)

011 = PWM Generator is triggered

010 = LEB is active

001 = Duty cycle is active (base PWM Generator signal)

000 = No termination qualifier used (qualifier forced to '1')

**Note 1:** Selects '0' if selected PWM Generator is not present.

# dsPIC33CK256MP508 FAMILY

## REGISTER 12-21: PGxLEBL: PWM GENERATOR x LEADING-EDGE BLANKING REGISTER LOW

R/W-0	R/W-0	R/W-0	R/W-0	R/W-0	R/W-0	R/W-0	R/W-0
LEB[15:8]							
bit 15							bit 8

R/W-0	R/W-0	R/W-0	R/W-0	R/W-0	R-0 <sup>(1)</sup>	R-0 <sup>(1)</sup>	R-0 <sup>(1)</sup>
LEB[7:0]							
bit 7							bit 0

### Legend:

R = Readable bit

W = Writable bit

U = Unimplemented bit, read as '0'

-n = Value at POR

'1' = Bit is set

'0' = Bit is cleared

x = Bit is unknown

bit 15-0     **LEB[15:0]:** Leading-Edge Blanking Period bits

Leading-Edge Blanking period. The three LSBs of the blanking time are not used, providing a blanking resolution of eight PGx\_clks. The minimum blanking period is eight PGx\_clks which occurs when LEB[15:3] = 0.

**Note 1:** Bits[2:0] are read-only and always remain as '0'.

# dsPIC33CK256MP508 FAMILY

## REGISTER 12-22: PGxLEBH: PWM GENERATOR x LEADING-EDGE BLANKING REGISTER HIGH

U-0	U-0	U-0	U-0	U-0	R/W-0	R/W-0	R/W-0
—	—	—	—	—	PWMPCI[2:0] <sup>(1)</sup>		
bit 15						bit 8	

U-0	U-0	U-0	U-0	R/W-0	R/W-0	R/W-0	R/W-0
—	—	—	—	PHR	PHF	PLR	PLF
bit 7						bit 0	

### Legend:

R = Readable bit      W = Writable bit      U = Unimplemented bit, read as '0'  
 -n = Value at POR      '1' = Bit is set      '0' = Bit is cleared      x = Bit is unknown

bit 15-11      **Unimplemented:** Read as '0'

bit 10-8      **PWMPCI[2:0]:** PWM Source for PCI Selection bits<sup>(1)</sup>

111 = PWM Generator #8 output is made available to PCI logic  
 110 = PWM Generator #7 output is made available to PCI logic  
 101 = PWM Generator #6 output is made available to PCI logic  
 100 = PWM Generator #5 output is made available to PCI logic  
 011 = PWM Generator #4 output is made available to PCI logic  
 010 = PWM Generator #3 output is made available to PCI logic  
 001 = PWM Generator #2 output is made available to PCI logic  
 000 = PWM Generator #1 output is made available to PCI logic

bit 7-4      **Unimplemented:** Read as '0'

bit 3      **PHR:** PWMxH Rising Edge Trigger Enable bit

1 = Rising edge of PWMxH will trigger the LEB duration counter  
 0 = LEB ignores the rising edge of PWMxH

bit 2      **PHF:** PWMxH Falling Edge Trigger Enable bit

1 = Falling edge of PWMxH will trigger the LEB duration counter  
 0 = LEB ignores the falling edge of PWMxH

bit 1      **PLR:** PWMxL Rising Edge Trigger Enable bit

1 = Rising edge of PWMxL will trigger the LEB duration counter  
 0 = LEB ignores the rising edge of PWMxL

bit 0      **PLF:** PWMxL Falling Edge Trigger Enable bit

1 = Falling edge of PWMxL will trigger the LEB duration counter  
 0 = LEB ignores the falling edge of PWMxL

**Note 1:** The selected PWM Generator source does not affect the LEB counter. This source can be optionally used as a PCI input, PCI qualifier, PCI terminator or PCI terminator qualifier (see the description in [Register 12-19](#) and [Register 12-20](#) for more information).

# dsPIC33CK256MP508 FAMILY

## REGISTER 12-23: PGxPHASE: PWM GENERATOR x PHASE REGISTER

R/W-0	R/W-0	R/W-0	R/W-0	R/W-0	R/W-0	R/W-0	R/W-0
PGxPHASE[15:8]							
bit 15				bit 8			

R/W-0	R/W-0	R/W-0	R/W-0	R/W-0	R/W-0	R/W-0	R/W-0
PGxPHASE[7:0]							
bit 7				bit 0			

### Legend:

R = Readable bit      W = Writable bit      U = Unimplemented bit, read as '0'  
-n = Value at POR      '1' = Bit is set      '0' = Bit is cleared      x = Bit is unknown

bit 15-0      **PGxPHASE[15:0]**: PWM Generator x Phase Register bits

## REGISTER 12-24: PGxDC: PWM GENERATOR x DUTY CYCLE REGISTER

R/W-0	R/W-0	R/W-0	R/W-0	R/W-0	R/W-0	R/W-0	R/W-0
PGxDC[15:8] <sup>(1)</sup>							
bit 15				bit 8			

R/W-0	R/W-0	R/W-0	R/W-0	R/W-0	R/W-0	R/W-0	R/W-0
PGxDC[7:0] <sup>(1)</sup>							
bit 7				bit 0			

### Legend:

R = Readable bit      W = Writable bit      U = Unimplemented bit, read as '0'  
-n = Value at POR      '1' = Bit is set      '0' = Bit is cleared      x = Bit is unknown

bit 15-0      **PGxDC[15:0]**: PWM Generator x Duty Cycle Register bits<sup>(1)</sup>

**Note 1:** Duty cycle values less than '0x0008' should not be used ('0x0020' in High-Resolution mode).

# dsPIC33CK256MP508 FAMILY

## REGISTER 12-25: PGxDCA: PWM GENERATOR x DUTY CYCLE ADJUSTMENT REGISTER

U-0	U-0	U-0	U-0	U-0	U-0	U-0	U-0
—	—	—	—	—	—	—	—
bit 15							bit 8

R/W-0	R/W-0	R/W-0	R/W-0	R/W-0	R/W-0	R/W-0	R/W-0
PGxDCA[7:0]							
bit 7							bit 0

### Legend:

R = Readable bit

W = Writable bit

U = Unimplemented bit, read as '0'

-n = Value at POR

'1' = Bit is set

'0' = Bit is cleared

x = Bit is unknown

bit 15-8 **Unimplemented:** Read as '0'

bit 7-0 **PGxDCA[7:0]:** PWM Generator x Duty Cycle Adjustment Value bits

Depending on the state of the selected PCI source, the PGxDCA value will be added to the value in the PGxDC register to create the effective duty cycle. When the PCI source is active, PGxDCA is added.

## REGISTER 12-26: PGxPER: PWM GENERATOR x PERIOD REGISTER

R/W-0	R/W-0	R/W-0	R/W-0	R/W-0	R/W-0	R/W-0	R/W-0
PGxPER[15:8] <sup>(1)</sup>							
bit 15							bit 8

R/W-0	R/W-0	R/W-0	R/W-0	R/W-0	R/W-0	R/W-0	R/W-0
PGxPER[7:0] <sup>(1)</sup>							
bit 7							bit 0

### Legend:

R = Readable bit

W = Writable bit

U = Unimplemented bit, read as '0'

-n = Value at POR

'1' = Bit is set

'0' = Bit is cleared

x = Bit is unknown

bit 15-0 **PGxPER[15:0]:** PWM Generator x Period Register bits<sup>(1)</sup>

**Note 1:** Period values less than '0x0010' should not be used ('0x0080' in High-Resolution mode).



# dsPIC33CK256MP508 FAMILY

## REGISTER 12-27: PGxTRIGA: PWM GENERATOR x TRIGGER A REGISTER

R/W-0	R/W-0	R/W-0	R/W-0	R/W-0	R/W-0	R/W-0	R/W-0
PGxTRIGA[15:8]							
bit 15							bit 8

R/W-0	R/W-0	R/W-0	R/W-0	R/W-0	R/W-0	R/W-0	R/W-0
PGxTRIGA[7:0]							
bit 7							bit 0

### Legend:

R = Readable bit      W = Writable bit      U = Unimplemented bit, read as '0'  
 -n = Value at POR      '1' = Bit is set      '0' = Bit is cleared      x = Bit is unknown

bit 15-0      **PGxTRIGA[15:0]**: PWM Generator x Trigger A Register bits

## REGISTER 12-28: PGxTRIGB: PWM GENERATOR x TRIGGER B REGISTER

R/W-0	R/W-0	R/W-0	R/W-0	R/W-0	R/W-0	R/W-0	R/W-0
PGxTRIGB[15:8]							
bit 15							bit 8

R/W-0	R/W-0	R/W-0	R/W-0	R/W-0	R/W-0	R/W-0	R/W-0
PGxTRIGB[7:0]							
bit 7							bit 0

### Legend:

R = Readable bit      W = Writable bit      U = Unimplemented bit, read as '0'  
 -n = Value at POR      '1' = Bit is set      '0' = Bit is cleared      x = Bit is unknown

bit 15-0      **PGxTRIGB[15:0]**: PWM Generator x Trigger B Register bits

## REGISTER 12-29: PGxTRIGC: PWM GENERATOR x TRIGGER C REGISTER

R/W-0	R/W-0	R/W-0	R/W-0	R/W-0	R/W-0	R/W-0	R/W-0
PGxTRIGC[15:8]							
bit 15							bit 8

R/W-0	R/W-0	R/W-0	R/W-0	R/W-0	R/W-0	R/W-0	R/W-0
PGxTRIGC[7:0]							
bit 7							bit 0

### Legend:

R = Readable bit      W = Writable bit      U = Unimplemented bit, read as '0'  
 -n = Value at POR      '1' = Bit is set      '0' = Bit is cleared      x = Bit is unknown

bit 15-0      **PGxTRIGC[15:0]**: PWM Generator x Trigger C Register bits

# dsPIC33CK256MP508 FAMILY

## REGISTER 12-30: PGxDTL: PWM GENERATOR x DEAD-TIME REGISTER LOW

U-0	U-0	R/W-0	R/W-0	R/W-0	R/W-0	R/W-0	R/W-0
—	—	DTL[13:8] <sup>(1)</sup>					
bit 15							bit 8

R/W-0	R/W-0	R/W-0	R/W-0	R/W-0	R/W-0	R/W-0	R/W-0
DTL[7:0]							
bit 7							bit 0

### Legend:

R = Readable bit                      W = Writable bit                      U = Unimplemented bit, read as '0'  
 -n = Value at POR                      '1' = Bit is set                      '0' = Bit is cleared                      x = Bit is unknown

bit 15-14    **Unimplemented:** Read as '0'  
 bit 13-0    **DTL[13:0]:** PWMxL Dead-Time Delay bits<sup>(1)</sup>

**Note 1:** DTL[13:11] bits are not available when HREN (PGxCONL[7]) = 0.

## REGISTER 12-31: PGxDTH: PWM GENERATOR x DEAD-TIME REGISTER HIGH

U-0	U-0	R/W-0	R/W-0	R/W-0	R/W-0	R/W-0	R/W-0
—	—	DTH[13:8] <sup>(1)</sup>					
bit 15							bit 8

R/W-0	R/W-0	R/W-0	R/W-0	R/W-0	R/W-0	R/W-0	R/W-0
DTH[7:0]							
bit 7							bit 0

### Legend:

R = Readable bit                      W = Writable bit                      U = Unimplemented bit, read as '0'  
 -n = Value at POR                      '1' = Bit is set                      '0' = Bit is cleared                      x = Bit is unknown

bit 15-14    **Unimplemented:** Read as '0'  
 bit 13-0    **DTH[13:0]:** PWMxH Dead-Time Delay bits<sup>(1)</sup>

**Note 1:** DTH[13:11] bits are not available when HREN (PGxCONL[7]) = 0.

# dsPIC33CK256MP508 FAMILY

## REGISTER 12-32: PGxCAP: PWM GENERATOR x CAPTURE REGISTER

R-0	R-0	R-0	R-0	R-0	R-0	R-0	R-0
PGxCAP[15:8]							
bit 15							
bit 8							

R-0	R-0	R-0	R-0	R-0	R-0	R-0	R/W-0
PGxCAP[7:0] <sup>(1)</sup>							
bit 7							
bit 0							

### Legend:

R = Readable bit

W = Writable bit

U = Unimplemented bit, read as '0'

-n = Value at POR

'1' = Bit is set

'0' = Bit is cleared

x = Bit is unknown

bit 15-0      **PGxCAP[15:0]:** PGx Time Base Capture bits<sup>(1)</sup>

**Note 1:** A capture event can be manually initiated in software by writing a '1' to PGxCAP[0]. The CAP bit (PGxSTAT[5]) will indicate when a new capture value is available. A read of PGxCAP will automatically clear the CAP bit and allow a new capture event to occur. The PGxCAP[1:0] bits will always read as '0'. In High-Resolution mode, the PGxCAP[4:0] bits will always read as '0'.

# dsPIC33CK256MP508 FAMILY

---

NOTES:

## 13.0 HIGH-SPEED, 12-BIT ANALOG-TO-DIGITAL CONVERTER (ADC)

**Note 1:** This data sheet summarizes the features of the dsPIC33CK256MP508 family of devices. It is not intended to be a comprehensive reference source. To complement the information in this data sheet, refer to “**12-Bit High-Speed, Multiple SARs A/D Converter (ADC)**” ([www.microchip.com/DS70005213](http://www.microchip.com/DS70005213)) in the “dsPIC33/PIC24 Family Reference Manual”.

**2:** Some registers and associated bits described in this section may not be available on all devices due to the number of implemented ADC channels. Refer to [Table 1](#) and [Table 2](#) for ADC channel availability on device variants.

The dsPIC33CK256MP508 devices have a high-speed, 12-bit Analog-to-Digital Converter (ADC) that features a low conversion latency, high resolution and over-sampling capabilities to improve performance in AC/DC, DC/DC power converters. The devices implement the ADC with three SAR cores, two dedicated and one shared.

The number of available channels and negative inputs is dependent on package size, as shown in [Table 13-1](#).

**TABLE 13-1: ADC EXTERNAL INPUT AVAILABILITY**

Package Type	External Inputs	Negative Inputs
80-pin	AN0-AN25	ANN0-ANN2
64-pin	AN0-AN19	ANN0-ANN2
48-pin	AN0-AN18	ANN0-ANN2
36-pin	AN0-AN15	ANN0
28-pin	AN0-AN11	—

### 13.1 ADC Features Overview

The High-Speed, 12-Bit Multiple SARs Analog-to-Digital Converter (ADC) includes the following features:

- Three ADC Cores: Two Dedicated Cores and One Shared (common) Core
- User-Configurable Resolution of up to 12 Bits for each Core
- Up to 3.5 Msps Conversion Rate per Channel at 12-Bit Resolution
- Low-Latency Conversion
- Up to 24 Analog Input Channels, with a Separate 16-Bit Conversion Result Register for each Input

- Conversion Result can be Formatted as Unsigned or Signed Data, on a per Channel Basis, for All Channels
- Simultaneous Sampling of up to Three Analog Inputs
- Channel Scan Capability
- Multiple Conversion Trigger Options for each Core, including:
  - PWM triggers from CPU cores
  - MCCP/SCCP modules triggers
  - CLC modules triggers
  - External pin trigger event (ADTRG31)
  - Software trigger
- Four Integrated Digital Comparators with Dedicated Interrupts:
  - Multiple comparison options
  - Assignable to specific analog inputs
- Four Oversampling Filters with Dedicated Interrupts:
  - Provide increased resolution
  - Assignable to a specific analog input

The module consists of three independent SAR ADC cores. Simplified block diagrams of the Multiple SARs 12-Bit ADC are shown in [Figure 13-1](#) and [Figure 13-2](#).

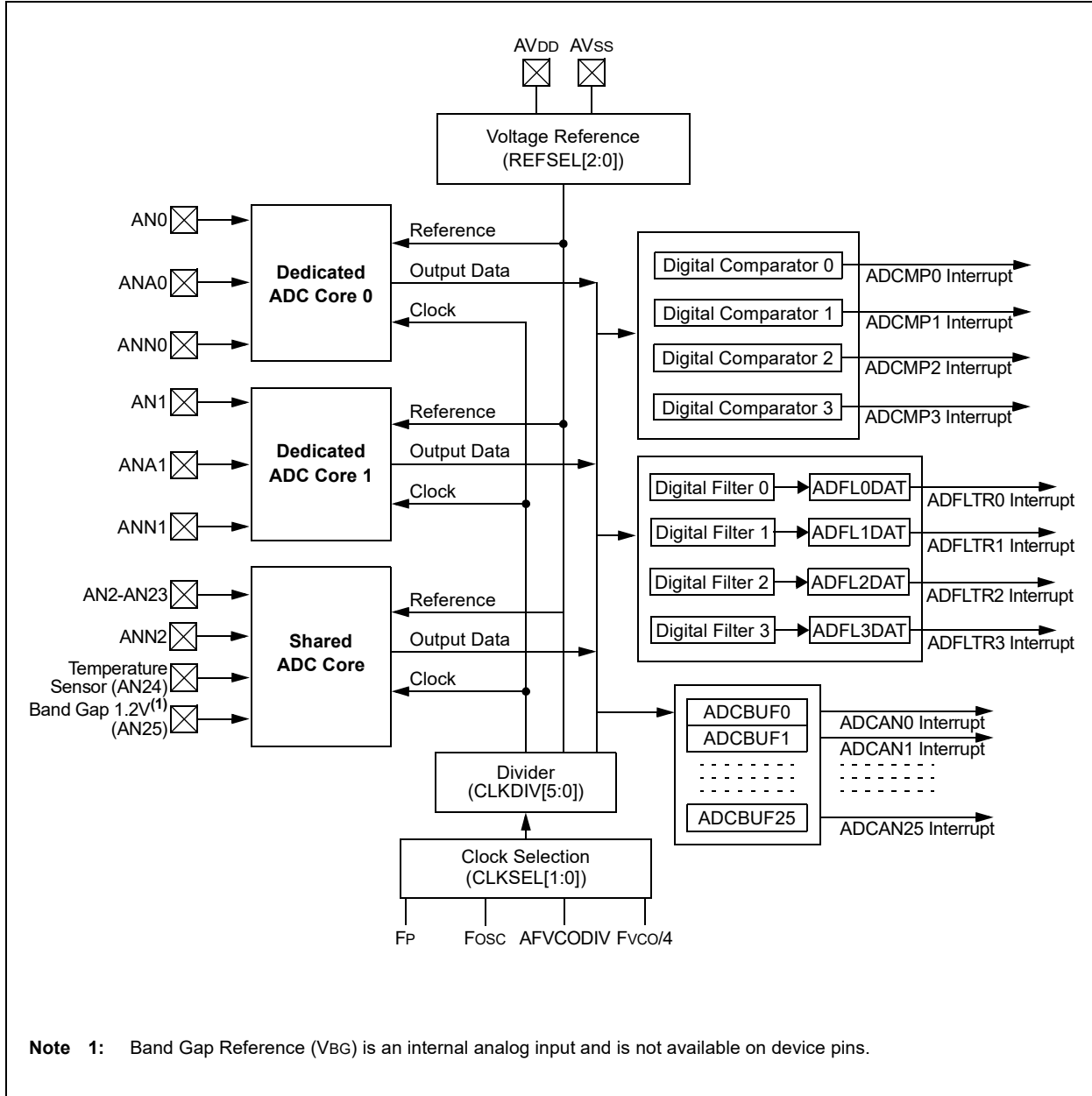
The analog inputs (channels) are connected through multiplexers and switches to the Sample-and-Hold (S&H) circuit of each ADC core. The core uses the channel information (the output format, the Measurement mode and the input number) to process the analog sample. When conversion is complete, the result is stored in the result buffer for the specific analog input, and passed to the digital filter and digital comparator if they were configured to use data from this particular channel.

The ADC module can sample up to three inputs at a time (two inputs from the dedicated SAR cores and one from the shared SAR core). If multiple ADC inputs request conversion on the shared core, the module will convert them in a sequential manner, starting with the lowest order input.

The ADC provides each analog input the ability to specify its own trigger source. This capability allows the ADC to sample and convert analog inputs that are associated with PWM generators operating on independent time bases.

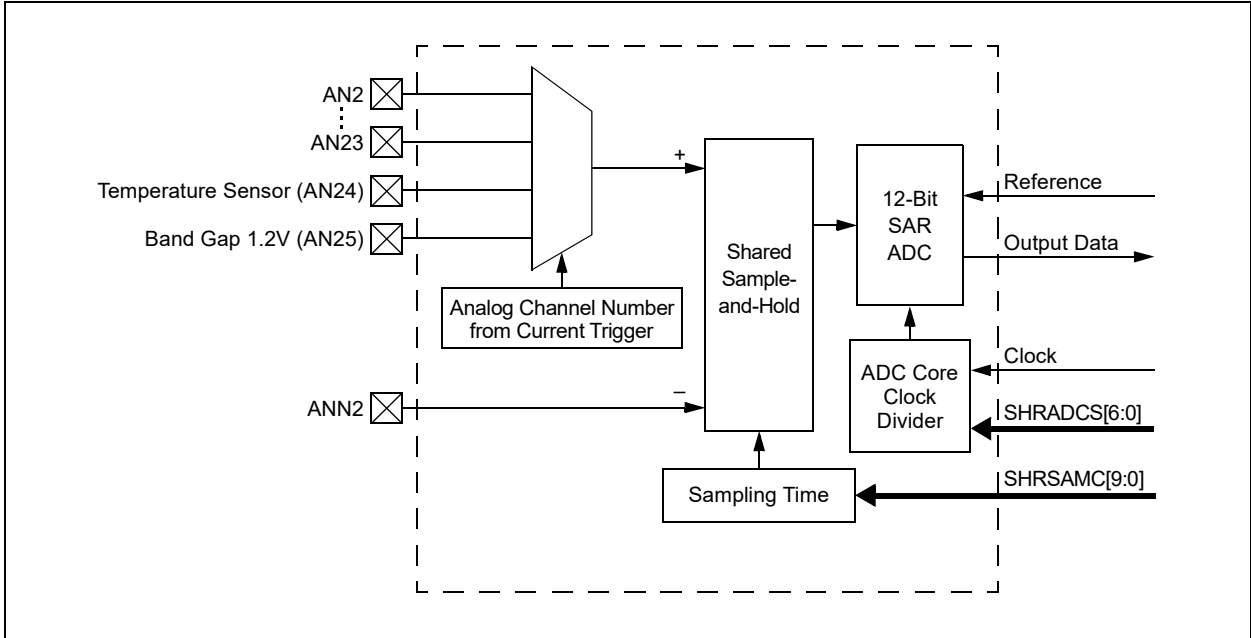
# dsPIC33CK256MP508 FAMILY

FIGURE 13-1: ADC MODULE BLOCK DIAGRAM

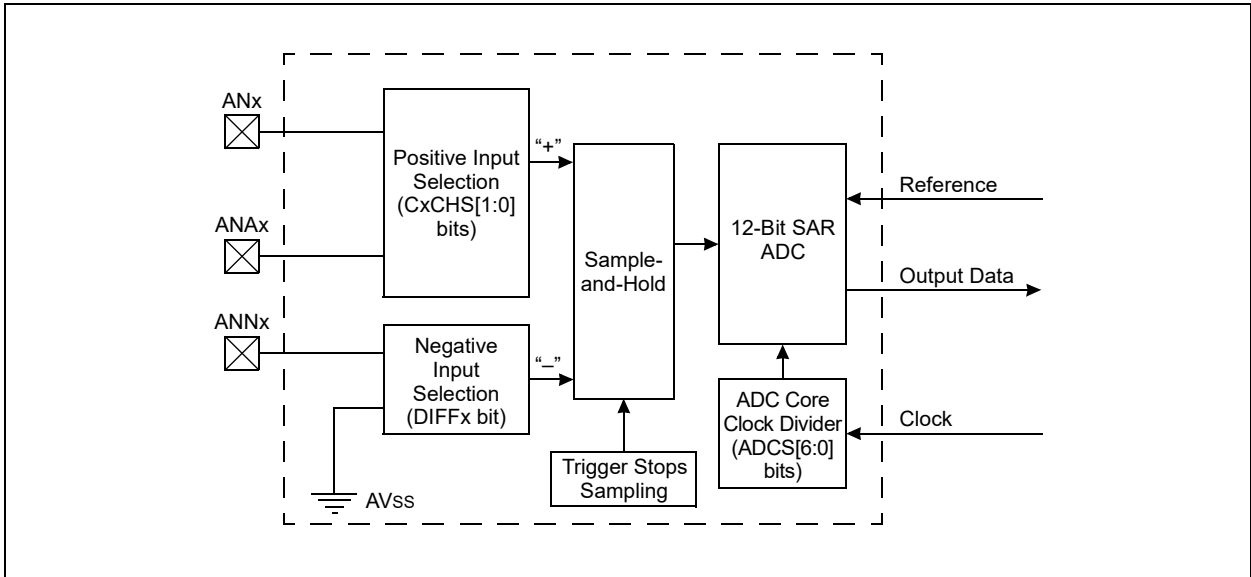


# dsPIC33CK256MP508 FAMILY

**FIGURE 13-2: ADC SHARED CORE BLOCK DIAGRAM**



**FIGURE 13-3: DEDICATED ADC CORE**



# dsPIC33CK256MP508 FAMILY

---

## 13.2 Temperature Sensor

The ADC channel, AN24, is connected to a forward-biased diode. It can be used to measure a die temperature. This diode provides a voltage output that can be monitored by the ADC.

The temperature coefficient is listed in [Table 33-39](#) in [Section 33.0 “Electrical Characteristics”](#). To get the exact gain and offset numbers, the two temperature points’ calibration is recommended.

## 13.3 Analog-to-Digital Converter Resources

Many useful resources are provided on the main product page of the Microchip website for the devices listed in this data sheet. This product page contains the latest updates and additional information.

## 13.4 Differential-Mode

ANNx negative external inputs are used for Differential-mode, as shown in [Figure 13-2](#). To enable Differential-mode, the DIFF bit (in ADMODxL or ADMODxH register) is set for the corresponding channel.

### 13.4.1 KEY RESOURCES

- **“12-Bit High-Speed, Multiple SARs A/D Converter (ADC)”** (DS70005213) in the *“dsPIC33/PIC24 Family Reference Manual”*
- Code Samples
- Application Notes
- Software Libraries
- Webinars
- All Related *“dsPIC33/PIC24 Family Reference Manual”* Sections
- Development Tools



# dsPIC33CK256MP508 FAMILY

## 13.5 Control Registers

**REGISTER 13-1: ADCON1L: ADC CONTROL REGISTER 1 LOW**

R/W-0	U-0	R/W-0	U-0	r-0	U-0	U-0	U-0
ADON <sup>(1)</sup>	—	ADSIDL	—	—	—	—	—
bit 15							bit 8

U-0	U-0	U-0	U-0	U-0	U-0	U-0	U-0
—	—	—	—	—	—	—	—
bit 7							bit 0

<b>Legend:</b>	r = Reserved bit
R = Readable bit	W = Writable bit
-n = Value at POR	'1' = Bit is set
	U = Unimplemented bit, read as '0'
	'0' = Bit is cleared
	x = Bit is unknown

- bit 15      **ADON:** ADC Enable bit<sup>(1)</sup>  
             1 = ADC module is enabled  
             0 = ADC module is off
- bit 14      **Unimplemented:** Read as '0'
- bit 13      **ADSIDL:** ADC Stop in Idle Mode bit  
             1 = Discontinues module operation when device enters Idle mode  
             0 = Continues module operation in Idle mode
- bit 12      **Unimplemented:** Read as '0'
- bit 11      **Reserved:** Maintain as '0'
- bit 10-0    **Unimplemented:** Read as '0'

**Note 1:** Set the ADON bit only after the ADC module has been configured. Changing ADC Configuration bits when ADON = 1 will result in unpredictable behavior.

# dsPIC33CK256MP508 FAMILY

## REGISTER 13-2: ADCON1H: ADC CONTROL REGISTER 1 HIGH

U-0	U-0	U-0	U-0	U-0	U-0	U-0	U-0
—	—	—	—	—	—	—	—
bit 15							bit 8

R/W-0	R/W-1	R/W-1	U-0	U-0	U-0	U-0	U-0
FORM	SHRRES1	SHRRES0	—	—	—	—	—
bit 7							bit 0

### Legend:

R = Readable bit

W = Writable bit

U = Unimplemented bit, read as '0'

-n = Value at POR

'1' = Bit is set

'0' = Bit is cleared

x = Bit is unknown

bit 15-8

**Unimplemented:** Read as '0'

bit 7

**FORM:** Fractional Data Output Format bit

1 = Fractional

0 = Integer

bit 6-5

**SHRRES[1:0]:** Shared ADC Core Resolution Selection bits

11 = 12-bit resolution

10 = 10-bit resolution

01 = 8-bit resolution

00 = 6-bit resolution

bit 4-0

**Unimplemented:** Read as '0'

# dsPIC33CK256MP508 FAMILY

## REGISTER 13-3: ADCON2L: ADC CONTROL REGISTER 2 LOW

R/W-0	R/W-0	U-0	R/W-0	R/W-0	R/W-0	R/W-0	R/W-0
REFCIE	REFERCIE	—	EIEN	PTGEN	SHREISEL2 <sup>(1)</sup>	SHREISEL1 <sup>(1)</sup>	SHREISEL0 <sup>(1)</sup>
bit 15							bit 8

U-0	R/W-0	R/W-0	R/W-0	R/W-0	R/W-0	R/W-0	R/W-0
—	SHRADCS[6:0]						—
bit 7							bit 0

### Legend:

R = Readable bit	W = Writable bit	U = Unimplemented bit, read as '0'
-n = Value at POR	'1' = Bit is set	'0' = Bit is cleared
		x = Bit is unknown

- bit 15     **REFCIE:** Band Gap and Reference Voltage Ready Common Interrupt Enable bit  
1 = Common interrupt will be generated when the band gap will become ready  
0 = Common interrupt is disabled for the band gap ready event
- bit 14     **REFERCIE:** Band Gap or Reference Voltage Error Common Interrupt Enable bit  
1 = Common interrupt will be generated when a band gap or reference voltage error is detected  
0 = Common interrupt is disabled for the band gap and reference voltage error event
- bit 13     **Unimplemented:** Read as '0'
- bit 12     **EIEN:** Early Interrupts Enable bit  
1 = The early interrupt feature is enabled for the input channel interrupts (when the E1STATx flag is set)  
0 = The individual interrupts are generated when conversion is done (when the ANxRDY flag is set)
- bit 11     **PTGEN:** External Conversion Request Interface bit  
Setting this bit will enable the PTG to request conversion of an ADC input.
- bit 10-8   **SHREISEL[2:0]:** Shared Core Early Interrupt Time Selection bits<sup>(1)</sup>  
111 = Early interrupt is set and interrupt is generated 8 TADCORE clocks prior to when the data are ready  
110 = Early interrupt is set and interrupt is generated 7 TADCORE clocks prior to when the data are ready  
101 = Early interrupt is set and interrupt is generated 6 TADCORE clocks prior to when the data are ready  
100 = Early interrupt is set and interrupt is generated 5 TADCORE clocks prior to when the data are ready  
011 = Early interrupt is set and interrupt is generated 4 TADCORE clocks prior to when the data are ready  
010 = Early interrupt is set and interrupt is generated 3 TADCORE clocks prior to when the data are ready  
001 = Early interrupt is set and interrupt is generated 2 TADCORE clocks prior to when the data are ready  
000 = Early interrupt is set and interrupt is generated 1 TADCORE clock prior to when the data are ready
- bit 7     **Unimplemented:** Read as '0'
- bit 6-0   **SHRADCS[6:0]:** Shared ADC Core Input Clock Divider bits  
These bits determine the number of TCOESRC (Source Clock Periods) for one shared TADCORE (Core Clock Period).  
11111111 = 254 Source Clock Periods  
...  
00000111 = 6 Source Clock Periods  
0000010 = 4 Source Clock Periods  
0000001 = 2 Source Clock Periods  
0000000 = 2 Source Clock Periods

**Note 1:** For the 6-bit shared ADC core resolution (SHRRES[1:0] = 00), the SHREISEL[2:0] settings, from '100' to '111', are not valid and should not be used. For the 8-bit shared ADC core resolution (SHRRES[1:0] = 01), the SHREISEL[2:0] settings, '110' and '111', are not valid and should not be used.

# dsPIC33CK256MP508 FAMILY

## REGISTER 13-4: ADCON2H: ADC CONTROL REGISTER 2 HIGH

HSC/R-0	HSC/R-0	U-0	r-0	r-0	r-0	R/W-0	R/W-0
REFRDY	REFERR	—	—	—	—	SHRSAMC[9:8]	
bit 15						bit 8	

R/W-0	R/W-0	R/W-0	R/W-0	R/W-0	R/W-0	R/W-0	R/W-0
SHRSAMC[7:0]							
bit 7						bit 0	

<b>Legend:</b>	r = Reserved bit	U = Unimplemented bit, read as '0'
R = Readable bit	W = Writable bit	HSC = Hardware Settable/Clearable bit
-n = Value at POR	'1' = Bit is set	'0' = Bit is cleared      x = Bit is unknown

- bit 15      **REFRDY:** Band Gap and Reference Voltage Ready Flag bit  
             1 = Band gap is ready  
             0 = Band gap is not ready
- bit 14      **REFERR:** Band Gap or Reference Voltage Error Flag bit  
             1 = Band gap was removed after the ADC module was enabled (ADON = 1)  
             0 = No band gap error was detected
- bit 13      **Unimplemented:** Read as '0'
- bit 12-10   **Reserved:** Maintain as '0'
- bit 9-0      **SHRSAMC[9:0]:** Shared ADC Core Sample Time Selection bits  
             These bits specify the number of shared ADC Core Clock Periods (TADCORE) for the shared ADC core sample time.  
             1111111111 = 1025 TADCORE  
             ...  
             0000000001 = 3 TADCORE  
             0000000000 = 2 TADCORE

# dsPIC33CK256MP508 FAMILY

## REGISTER 13-5: ADCON3L: ADC CONTROL REGISTER 3 LOW

R/W-0	R/W-0	R/W-0	R/W-0	R/W-0	HSC/R-0	R/W-0	HSC/R-0
REFSEL2	REFSEL1	REFSEL0	SUSPEND	SUSPCIE	SUSPRDY	SHRSAMP	CNVRTCH
bit 15						bit 8	

R/W-0	HSC/R-0	R/W-0	R/W-0	R/W-0	R/W-0	R/W-0	R/W-0
SWLCTRG	SWCTRG	CNVCHSEL5	CNVCHSEL4	CNVCHSEL3	CNVCHSEL2	CNVCHSEL1	CNVCHSEL0
bit 7						bit 0	

<b>Legend:</b>	U = Unimplemented bit, read as '0'
R = Readable bit	W = Writable bit
-n = Value at POR	'1' = Bit is set
	HSC = Hardware Settable/Clearable bit
	'0' = Bit is cleared
	x = Bit is unknown

bit 15-13 **REFSEL[2:0]:** ADC Reference Voltage Selection bits

Value	VREFH	VREFL
000	AVDD	AVSS

001-111 = **Unimplemented:** Do not use

bit 12 **SUSPEND:** All ADC Core Triggers Disable bit

1 = All new trigger events for all ADC cores are disabled  
0 = All ADC cores can be triggered

bit 11 **SUSPCIE:** Suspend All ADC Cores Common Interrupt Enable bit

1 = Common interrupt will be generated when ADC core triggers are suspended (SUSPEND bit = 1) and all previous conversions are finished (SUSPRDY bit becomes set)  
0 = Common interrupt is not generated for suspend ADC cores event

bit 10 **SUSPRDY:** All ADC Cores Suspended Flag bit

1 = All ADC cores are suspended (SUSPEND bit = 1) and have no conversions in progress  
0 = ADC cores have previous conversions in progress

bit 9 **SHRSAMP:** Shared ADC Core Sampling Direct Control bit

This bit should be used with the individual channel conversion trigger controlled by the CNVRTCH bit. It connects an analog input, specified by the CNVCHSEL[5:0] bits, to the shared ADC core and allows extending the sampling time. This bit is not controlled by hardware.  
1 = Shared ADC core samples an analog input specified by the CNVCHSEL[5:0] bits  
0 = Sampling is controlled by the shared ADC core hardware

bit 8 **CNVRTCH:** Software Individual Channel Conversion Trigger bit

1 = Single trigger is generated for an analog input specified by the CNVCHSEL[5:0] bits; when the bit is set, it is automatically cleared by hardware on the next instruction cycle  
0 = Next individual channel conversion trigger can be generated

bit 7 **SWLCTRG:** Software Level-Sensitive Common Trigger bit

1 = Triggers are continuously generated for all channels with the software, level-sensitive common trigger selected as a source in the ADTRIGNL and ADTRIGNH registers  
0 = No software, level-sensitive common triggers are generated

bit 6 **SWCTRG:** Software Common Trigger bit

1 = Single trigger is generated for all channels with the software; common trigger selected as a source in the ADTRIGNL and ADTRIGNH registers; when the bit is set, it is automatically cleared by hardware on the next instruction cycle  
0 = Ready to generate the next software common trigger

bit 5-0 **CNVCHSEL [5:0]:** Channel Number Selection for Software Individual Channel Conversion Trigger bits

These bits define a channel to be converted when the CNVRTCH bit is set.

# dsPIC33CK256MP508 FAMILY

## REGISTER 13-6: ADCON3H: ADC CONTROL REGISTER 3 HIGH

R/W-0	R/W-0	R/W-0	R/W-0	R/W-0	R/W-0	R/W-0	R/W-0
CLKSEL1 <sup>(1)</sup>	CLKSEL0 <sup>(1)</sup>	CLKDIV5 <sup>(2)</sup>	CLKDIV4 <sup>(2)</sup>	CLKDIV3 <sup>(2)</sup>	CLKDIV2 <sup>(2)</sup>	CLKDIV1 <sup>(2)</sup>	CLKDIV0 <sup>(2)</sup>
bit 15						bit 8	

R/W-0	U-0	U-0	U-0	U-0	U-0	R/W-0	R/W-0
SHREN	—	—	—	—	—	C1EN	C0EN
bit 7						bit 0	

### Legend:

R = Readable bit                      W = Writable bit                      U = Unimplemented bit, read as '0'  
 -n = Value at POR                      '1' = Bit is set                      '0' = Bit is cleared                      x = Bit is unknown

bit 15-14      **CLKSEL[1:0]:** ADC Module Clock Source Selection bits<sup>(1)</sup>

11 = Fvco/4  
 10 = AFVCO DIV  
 01 = FOSC  
 00 = FP (Peripheral Clock)

bit 13-8      **CLKDIV[5:0]:** ADC Module Clock Source Divider bits<sup>(2)</sup>

The divider forms a Tcoresrc clock used by all ADC cores (shared and dedicated) from the Tsrc ADC module clock source selected by the CLKSEL[1:0] bits. Then, each ADC core individually divides the Tcoresrc clock to get a core-specific Tadc core clock using the ADCS[6:0] bits in the ADCORExH register or the SHRADCS[6:0] bits in the ADCON2L register.

111111 = 64 Source Clock Periods  
 ...  
 000011 = 4 Source Clock Periods  
 000010 = 3 Source Clock Periods  
 000001 = 2 Source Clock Periods  
 000000 = 1 Source Clock Period

bit 7      **SHREN:** Shared ADC Core Enable bit

1 = Shared ADC core is enabled  
 0 = Shared ADC core is disabled

bit 6-2      **Unimplemented:** Read as '0'

bit 1      **C1EN:** Dedicated ADC Core 1 Enable bits

1 = Dedicated ADC Core 1 is enabled  
 0 = Dedicated ADC Core 1 is disabled

bit 0      **C0EN:** Dedicated ADC Core 0 Enable bits

1 = Dedicated ADC Core 0 is enabled  
 0 = Dedicated ADC Core 0 is disabled

**Note 1:** The ADC input clock frequency, selected by the CLKSEL[1:0] bits, must not exceed [AD67](#) listed in [Table 33-39](#).

**2:** The ADC clock frequency, after the divider selected by the CLKDIV[5:0] bits, must not exceed [AD67](#) listed in [Table 33-39](#).

# dsPIC33CK256MP508 FAMILY

## REGISTER 13-7: ADCON4L: ADC CONTROL REGISTER 4 LOW

U-0	U-0	U-0	U-0	U-0	U-0	r-0	r-0
—	—	—	—	—	—	—	—
bit 15						bit 8	

U-0	U-0	U-0	U-0	U-0	U-0	R/W-0	R/W-0
—	—	—	—	—	—	SAMC1EN	SAMC0EN
bit 7						bit 0	

<b>Legend:</b>	r = Reserved bit
R = Readable bit	W = Writable bit
-n = Value at POR	'1' = Bit is set
	'0' = Bit is cleared
	x = Bit is unknown

- bit 15-10    **Unimplemented:** Read as '0'
- bit 9-8     **Reserved:** Must be written as '0'
- bit 7-2     **Unimplemented:** Read as '0'
- bit 1       **SAMC1EN:** Dedicated ADC Core 1 Conversion Delay Enable bit
  - 1 = After trigger, the conversion will be delayed and the ADC core will continue sampling during the time specified by the SAMC[9:0] bits in the ADCORE1L register
  - 0 = After trigger, the sampling will be stopped immediately and the conversion will be started on the next core clock cycle
- bit 0       **SAMC0EN:** Dedicated ADC Core 0 Conversion Delay Enable bit
  - 1 = After trigger, the conversion will be delayed and the ADC core will continue sampling during the time specified by the SAMC[9:0] bits in the ADCORE0L register
  - 0 = After trigger, the sampling will be stopped immediately and the conversion will be started on the next core clock cycle

# dsPIC33CK256MP508 FAMILY

## REGISTER 13-8: ADCON4H: ADC CONTROL REGISTER 4 HIGH

U-0	U-0	U-0	U-0	U-0	U-0	U-0	U-0
—	—	—	—	—	—	—	—
bit 15						bit 8	

U-0	U-0	U-0	U-0	R/W-0	R/W-0	R/W-0	R/W-0
—	—	—	—	C1CHS1	C1CHS0	C0CHS1	C0CHS0
bit 7				bit 0			

### Legend:

R = Readable bit

W = Writable bit

U = Unimplemented bit, read as '0'

-n = Value at POR

'1' = Bit is set

'0' = Bit is cleared

x = Bit is unknown

bit 15-4

**Unimplemented:** Read as '0'

bit 3-2

**C1CHS[1:0]:** Dedicated ADC Core 1 Input Channel Selection bits

11 = Reserved

10 = Reserved

01 = ANA1

00 = AN1

bit 1-0

**C0CHS[1:0]:** Dedicated ADC Core 0 Input Channel Selection bits

11 = Reserved

10 = Reserved

01 = ANA0

00 = AN0



# dsPIC33CK256MP508 FAMILY

## REGISTER 13-9: ADCON5L: ADC CONTROL REGISTER 5 LOW

HSC/R-0	U-0	U-0	U-0	U-0	U-0	HSC/R-0	HSC/R-0
SHRRDY	—	—	—	—	—	C1RDY	C0RDY
bit 15						bit 8	

R/W-0	U-0	U-0	U-0	U-0	U-0	R/W-0	R/W-0
SHRPWR	—	—	—	—	—	C1PWR	C0PWR
bit 7						bit 0	

<b>Legend:</b>	U = Unimplemented bit, read as '0'
R = Readable bit	W = Writable bit
-n = Value at POR	'1' = Bit is set
	'0' = Bit is cleared
	x = Bit is unknown
	HSC = Hardware Settable/Clearable bit

- bit 15     **SHRRDY:** Shared ADC Core Ready Flag bit  
           1 = ADC core is powered and ready for operation  
           0 = ADC core is not ready for operation
- bit 14-10   **Unimplemented:** Read as '0'
- bit 9       **C1RDY:** Dedicated ADC Core 1 Ready Flag bit  
           1 = ADC Core 1 is powered and ready for operation  
           0 = ADC Core 1 is not ready for operation
- bit 8       **C0RDY:** Dedicated ADC Core 0 Ready Flag bit  
           1 = ADC Core 0 is powered and ready for operation  
           0 = ADC Core 0 is not ready for operation
- bit 7       **SHRPWR:** Shared ADC Core Power Enable bit  
           1 = ADC core is powered  
           0 = ADC core is off
- bit 6-2     **Unimplemented:** Read as '0'
- bit 1       **C1PWR:** Dedicated ADC Core 1 Power Enable bit  
           1 = ADC Core 1 is powered  
           0 = ADC Core 1 is off
- bit 0       **C0PWR:** Dedicated ADC Core 0 Power Enable bit  
           1 = ADC Core 0 is powered  
           0 = ADC Core 0 is off

# dsPIC33CK256MP508 FAMILY

## REGISTER 13-10: ADCON5H: ADC CONTROL REGISTER 5 HIGH

U-0	U-0	U-0	U-0	R/W-0	R/W-0	R/W-0	R/W-0
—	—	—	—	WARMTIME[3:0]			
bit 15				bit 8			

R/W-0	U-0	U-0	U-0	U-0	U-0	R/W-0	R/W-0
SHRCIE	—	—	—	—	—	C1CIE	C0CIE
bit 7						bit 0	

### Legend:

R = Readable bit

W = Writable bit

U = Unimplemented bit, read as '0'

-n = Value at POR

'1' = Bit is set

'0' = Bit is cleared

x = Bit is unknown

bit 15-12 **Unimplemented:** Read as '0'

bit 11-8 **WARMTIME[3:0]:** ADC Dedicated Core x Power-up Delay bits

These bits determine the power-up delay in the number of the Core Source Clock Periods (TCORESRC) for all ADC cores.

1111 = 32768 Source Clock Periods

1110 = 16384 Source Clock Periods

1101 = 8192 Source Clock Periods

1100 = 4096 Source Clock Periods

1011 = 2048 Source Clock Periods

1010 = 1024 Source Clock Periods

1001 = 512 Source Clock Periods

1000 = 256 Source Clock Periods

0111 = 128 Source Clock Periods

0110 = 64 Source Clock Periods

0101 = 32 Source Clock Periods

0100 = 16 Source Clock Periods

00xxx = 16 Source Clock Periods

bit 7 **SHRCIE:** Shared ADC Core Ready Common Interrupt Enable bit

1 = Common interrupt will be generated when ADC core is powered and ready for operation

0 = Common interrupt is disabled for an ADC core ready event

bit 6-2 **Unimplemented:** Read as '0'

bit 1 **C1CIE:** Dedicated ADC Core 1 Ready Common Interrupt Enable bit

1 = Common interrupt will be generated when ADC Core 1 is powered and ready for operation

0 = Common interrupt is disabled for an ADC Core 1 ready event

bit 0 **C0CIE:** Dedicated ADC Core 0 Ready Common Interrupt Enable bit

1 = Common interrupt will be generated when ADC Core 0 is powered and ready for operation

0 = Common interrupt is disabled for an ADC Core 0 ready event

# dsPIC33CK256MP508 FAMILY

## REGISTER 13-11: ADCORExL: DEDICATED ADC CORE x CONTROL REGISTER LOW (x = 0 TO 1)

U-0	U-0	U-0	U-0	U-0	U-0	R/W-0	R/W-0
—	—	—	—	—	—	SAMC[9:8]	
bit 15						bit 8	

R/W-0	R/W-0	R/W-0	R/W-0	R/W-0	R/W-0	R/W-0	R/W-0
SAMC[7:0]							
bit 7						bit 0	

<b>Legend:</b>			
R = Readable bit	W = Writable bit	U = Unimplemented bit, read as '0'	
-n = Value at POR	'1' = Bit is set	'0' = Bit is cleared	x = Bit is unknown

bit 15-10 **Unimplemented:** Read as '0'

bit 9-0 **SAMC[9:0]:** Dedicated ADC Core x Conversion Delay Selection bits

These bits determine the time between the trigger event and the start of conversion in the number of the Core Clock Periods (TADCORE). During this time, the ADC Core x still continues sampling. This feature is enabled by the SAMCxEN bits in the ADCON4L register.

1111111111 = 1025 TADCORE

...

0000000001 = 3 TADCORE

0000000000 = 2 TADCORE

# dsPIC33CK256MP508 FAMILY

## REGISTER 13-12: ADCORExH: DEDICATED ADC CORE x CONTROL REGISTER HIGH (x = 0 TO 1)

U-0	U-0	U-0	R/W-0	R/W-0	R/W-0	R/W-0	R/W-0
—	—	—	EISEL2	EISEL1	EISEL0	RES1	RES2
bit 15						bit 8	

U-0	R/W-0	R/W-0	R/W-0	R/W-0	R/W-0	R/W-0	R/W-0
—	ADCS[6:0]						—
bit 7							bit 0

### Legend:

R = Readable bit      W = Writable bit      U = Unimplemented bit, read as '0'  
 -n = Value at POR      '1' = Bit is set      '0' = Bit is cleared      x = Bit is unknown

bit 15-13 **Unimplemented:** Read as '0'

bit 12-10 **EISEL[2:0]:** ADC Core x Early Interrupt Time Selection bits

111 = Early interrupt is set and an interrupt is generated 8 TADCORE clocks prior to when the data are ready  
 110 = Early interrupt is set and an interrupt is generated 7 TADCORE clocks prior to when the data are ready  
 101 = Early interrupt is set and an interrupt is generated 6 TADCORE clocks prior to when the data are ready  
 100 = Early interrupt is set and an interrupt is generated 5 TADCORE clocks prior to when the data are ready  
 011 = Early interrupt is set and an interrupt is generated 4 TADCORE clocks prior to when the data are ready  
 010 = Early interrupt is set and an interrupt is generated 3 TADCORE clocks prior to when the data are ready  
 001 = Early interrupt is set and an interrupt is generated 2 TADCORE clocks prior to when the data are ready  
 000 = Early interrupt is set and an interrupt is generated 1 TADCORE clock prior to when the data are ready

bit 9-8 **RES[1:0]:** ADC Core x Resolution Selection bits

11 = 12-bit resolution  
 10 = 10-bit resolution  
 01 = 8-bit resolution<sup>(1)</sup>  
 00 = 6-bit resolution<sup>(1)</sup>

bit 7 **Unimplemented:** Read as '0'

bit 6-0 **ADCS[6:0]:** ADC Core x Input Clock Divider bits

These bits determine the number of Source Clock Periods (TCORESRC) for one Core Clock Period (TADCORE).  
 1111111 = 254 Source Clock Periods  
 ...  
 0000011 = 6 Source Clock Periods  
 0000010 = 4 Source Clock Periods  
 0000001 = 2 Source Clock Periods  
 0000000 = 2 Source Clock Periods

**Note 1:** For the 6-bit ADC core resolution (RES[1:0] = 00), the EISEL[2:0] bits setting, from '100' to '111', are not valid and should not be used. For the 8-bit ADC core resolution (RES[1:0] = 01), the EISEL[2:0] bits setting, '110' and '111', are not valid and should not be used.

# dsPIC33CK256MP508 FAMILY

## REGISTER 13-13: ADLVLTRGL: ADC LEVEL-SENSITIVE TRIGGER CONTROL REGISTER LOW<sup>(1)</sup>

R/W-0	R/W-0	R/W-0	R/W-0	R/W-0	R/W-0	R/W-0	R/W-0
LVLEN[15:8]							
bit 15				bit 8			

R/W-0	R/W-0	R/W-0	R/W-0	R/W-0	R/W-0	R/W-0	R/W-0
LVLEN[7:0]							
bit 7				bit 0			

### Legend:

R = Readable bit                      W = Writable bit                      U = Unimplemented bit, read as '0'  
 -n = Value at POR                      '1' = Bit is set                      '0' = Bit is cleared                      x = Bit is unknown

bit 15-0      **LVLEN[15:0]:** Level Trigger for Corresponding Analog Input Enable bits  
                   1 = Input trigger is level-sensitive  
                   0 = Input trigger is edge-sensitive

**Note 1:** Bit availability is dependent on the number of supported ADC channels. Refer to [Table 1](#) and [Table 2](#) for ADC channel availability on package variants.

## REGISTER 13-14: ADLVLTRGH: ADC LEVEL-SENSITIVE TRIGGER CONTROL REGISTER HIGH<sup>(1)</sup>

U-0	U-0	U-0	U-0	U-0	U-0	R/W-0	R/W-0
—	—	—	—	—	—	LVLEN[25:24]	
bit 15						bit 8	

R/W-0	R/W-0	R/W-0	R/W-0	R/W-0	R/W-0	R/W-0	R/W-0
LVLEN[23:16]							
bit 7				bit 0			

### Legend:

R = Readable bit                      W = Writable bit                      U = Unimplemented bit, read as '0'  
 -n = Value at POR                      '1' = Bit is set                      '0' = Bit is cleared                      x = Bit is unknown

bit 15-10      **Unimplemented:** Read as '0'  
 bit 9-0      **LVLEN[25:16]:** Level Trigger for Corresponding Analog Input Enable bits  
                   1 = Input trigger is level-sensitive  
                   0 = Input trigger is edge-sensitive

**Note 1:** Bit availability is dependent on the number of supported ADC channels. Refer to [Table 1](#) and [Table 2](#) for ADC channel availability on package variants.

# dsPIC33CK256MP508 FAMILY

## REGISTER 13-15: ADEIEL: ADC EARLY INTERRUPT ENABLE REGISTER LOW<sup>(1)</sup>

R/W-0	R/W-0	R/W-0	R/W-0	R/W-0	R/W-0	R/W-0	R/W-0
EIEN[15:8]							
bit 15				bit 8			

R/W-0	R/W-0	R/W-0	R/W-0	R/W-0	R/W-0	R/W-0	R/W-0
EIEN[7:0]							
bit 7				bit 0			

### Legend:

R = Readable bit                      W = Writable bit                      U = Unimplemented bit, read as '0'  
 -n = Value at POR                      '1' = Bit is set                      '0' = Bit is cleared                      x = Bit is unknown

bit 15-0            **EIEN[15:0]:** Early Interrupt Enable for Corresponding Analog Inputs bits  
                          1 = Early interrupt is enabled for the channel  
                          0 = Early interrupt is disabled for the channel

**Note 1:** Bit availability is dependent on the number of supported ADC channels. Refer to [Table 1](#) and [Table 2](#) for ADC channel availability on package variants.

## REGISTER 13-16: ADEIEH: ADC EARLY INTERRUPT ENABLE REGISTER HIGH<sup>(1)</sup>

U-0	U-0	U-0	U-0	U-0	U-0	R/W-0	R/W-0
—	—	—	—	—	—	EIEN[25:24]	
bit 15						bit 8	

R/W-0	R/W-0	R/W-0	R/W-0	R/W-0	R/W-0	R/W-0	R/W-0
EIEN[23:16]							
bit 7				bit 0			

### Legend:

R = Readable bit                      W = Writable bit                      U = Unimplemented bit, read as '0'  
 -n = Value at POR                      '1' = Bit is set                      '0' = Bit is cleared                      x = Bit is unknown

bit 15-10            **Unimplemented:** Read as '0'  
 bit 9-0              **EIEN[25:16]:** Early Interrupt Enable for Corresponding Analog Inputs bits  
                          1 = Early interrupt is enabled for the channel  
                          0 = Early interrupt is disabled for the channel

**Note 1:** Bit availability is dependent on the number of supported ADC channels. Refer to [Table 1](#) and [Table 2](#) for ADC channel availability on package variants.

# dsPIC33CK256MP508 FAMILY

## REGISTER 13-17: ADEISTATL: ADC EARLY INTERRUPT STATUS REGISTER LOW<sup>(1)</sup>

R/W-0	R/W-0	R/W-0	R/W-0	R/W-0	R/W-0	R/W-0	R/W-0
EISTAT[15:8]							
bit 15				bit 8			

R/W-0	R/W-0	R/W-0	R/W-0	R/W-0	R/W-0	R/W-0	R/W-0
EISTAT[7:0]							
bit 7				bit 0			

### Legend:

R = Readable bit                      W = Writable bit                      U = Unimplemented bit, read as '0'  
 -n = Value at POR                      '1' = Bit is set                      '0' = Bit is cleared                      x = Bit is unknown

bit 15-0      **EISTAT[15:0]:** Early Interrupt Status for Corresponding Analog Inputs bits  
                   1 = Early interrupt was generated  
                   0 = Early interrupt was not generated since the last ADCBUFx read

**Note 1:** Bit availability is dependent on the number of supported ADC channels. Refer to [Table 1](#) and [Table 2](#) for ADC channel availability on package variants.

## REGISTER 13-18: ADEISTATH: ADC EARLY INTERRUPT STATUS REGISTER HIGH<sup>(1)</sup>

U-0	U-0	U-0	U-0	U-0	U-0	R/W-0	R/W-0
—	—	—	—	—	—	EISTAT[25:24]	
bit 15						bit 8	

R/W-0	R/W-0	R/W-0	R/W-0	R/W-0	R/W-0	R/W-0	R/W-0
EISTAT[23:16]							
bit 7						bit 0	

### Legend:

R = Readable bit                      W = Writable bit                      U = Unimplemented bit, read as '0'  
 -n = Value at POR                      '1' = Bit is set                      '0' = Bit is cleared                      x = Bit is unknown

bit 15-10      **Unimplemented:** Read as '0'  
 bit 9-0      **EISTAT[25:16]:** Early Interrupt Status for Corresponding Analog Inputs bits  
                   1 = Early interrupt was generated  
                   0 = Early interrupt was not generated since the last ADCBUFx read

**Note 1:** Bit availability is dependent on the number of supported ADC channels. Refer to [Table 1](#) and [Table 2](#) for ADC channel availability on package variants.

# dsPIC33CK256MP508 FAMILY

## REGISTER 13-19: ADMOD0L: ADC INPUT MODE CONTROL REGISTER 0 LOW

R/W-0	R/W-0	R/W-0	R/W-0	R/W-0	R/W-0	R/W-0	R/W-0
DIFF7	SIGN7	DIFF6	SIGN6	DIFF5	SIGN5	DIFF4	SIGN4
bit 15						bit 8	

R/W-0	R/W-0	R/W-0	R/W-0	R/W-0	R/W-0	R/W-0	R/W-0
DIFF3	SIGN3	DIFF2	SIGN2	DIFF1	SIGN1	DIFF0	SIGN0
bit 7						bit 0	

### Legend:

R = Readable bit                      W = Writable bit                      U = Unimplemented bit, read as '0'  
 -n = Value at POR                      '1' = Bit is set                      '0' = Bit is cleared                      x = Bit is unknown

bit 15 through bit 1 (odd) **DIFF[7:0]:** Differential-Mode for Corresponding Analog Inputs bits  
 1 = Channel is differential  
 0 = Channel is single-ended

bit 14 through bit 0 (even) **SIGN[7:0]:** Output Data Sign for Corresponding Analog Inputs bits  
 1 = Channel output data are signed  
 0 = Channel output data are unsigned

## REGISTER 13-20: ADMOD0H: ADC INPUT MODE CONTROL REGISTER 0 HIGH<sup>(1)</sup>

R/W-0	R/W-0	R/W-0	R/W-0	R/W-0	R/W-0	R/W-0	R/W-0
DIFF15	SIGN15	DIFF14	SIGN14	DIFF13	SIGN13	DIFF12	SIGN12
bit 15						bit 8	

R/W-0	R/W-0	R/W-0	R/W-0	R/W-0	R/W-0	R/W-0	R/W-0
DIFF11	SIGN11	DIFF10	SIGN10	DIFF9	SIGN9	DIFF8	SIGN8
bit 7						bit 0	

### Legend:

R = Readable bit                      W = Writable bit                      U = Unimplemented bit, read as '0'  
 -n = Value at POR                      '1' = Bit is set                      '0' = Bit is cleared                      x = Bit is unknown

bit 15 through bit 1 (odd) **DIFF[15:8]:** Differential-Mode for Corresponding Analog Inputs bits  
 1 = Channel is differential  
 0 = Channel is single-ended

bit 14 through bit 0 (even) **SIGN[15:8]:** Output Data Sign for Corresponding Analog Inputs bits  
 1 = Channel output data are signed  
 0 = Channel output data are unsigned

**Note 1:** Bit availability is dependent on the number of supported ADC channels. Refer to [Table 1](#) and [Table 2](#) for ADC channel availability on package variants.



# dsPIC33CK256MP508 FAMILY

## REGISTER 13-21: ADMOD1L: ADC INPUT MODE CONTROL REGISTER 1 LOW<sup>(1)</sup>

R/W-0	R/W-0	R/W-0	R/W-0	R/W-0	R/W-0	R/W-0	R/W-0
DIFF23	SIGN23	DIFF22	SIGN22	DIFF21	SIGN21	DIFF20	SIGN20
bit 15							bit 8

R/W-0	R/W-0	R/W-0	R/W-0	R/W-0	R/W-0	R/W-0	R/W-0
DIFF19	SIGN19	DIFF18	SIGN18	DIFF17	SIGN17	DIFF16	SIGN16
bit 7							bit 0

### Legend:

R = Readable bit                      W = Writable bit                      U = Unimplemented bit, read as '0'  
 -n = Value at POR                      '1' = Bit is set                      '0' = Bit is cleared                      x = Bit is unknown

bit 15 through bit 1 (odd) **DIFF[23:16]:** Differential-Mode for Corresponding Analog Inputs bits  
 1 = Channel is differential  
 0 = Channel is single-ended

bit 14 through bit 0 (even) **SIGN[23:16]:** Output Data Sign for Corresponding Analog Inputs bits  
 1 = Channel output data are signed  
 0 = Channel output data are unsigned

**Note 1:** Bit availability is dependent on the number of supported ADC channels. Refer to [Table 1](#) and [Table 2](#) for ADC channel availability on package variants.

## REGISTER 13-22: ADMOD1H: ADC INPUT MODE CONTROL REGISTER 1 HIGH<sup>(1)</sup>

U-0	U-0	U-0	U-0	U-0	U-0	U-0	U-0
—	—	—	—	—	—	—	—
bit 15							bit 8

U-0	U-0	U-0	U-0	R/W-0	R/W-0	R/W-0	R/W-0
—	—	—	—	DIFF25	SIGN25	DIFF24	SIGN24
bit 7							bit 0

### Legend:

R = Readable bit                      W = Writable bit                      U = Unimplemented bit, read as '0'  
 -n = Value at POR                      '1' = Bit is set                      '0' = Bit is cleared                      x = Bit is unknown

bit 3 through bit 1 (odd) **DIFF[25:24]:** Differential-Mode for Corresponding Analog Inputs bits  
 1 = Channel is differential  
 0 = Channel is single-ended

bit 2 through bit 0 (even) **SIGN[25:24]:** Output Data Sign for Corresponding Analog Inputs bits  
 1 = Channel output data are signed  
 0 = Channel output data are unsigned

**Note 1:** Bit availability is dependent on the number of supported ADC channels. Refer to [Table 1](#) and [Table 2](#) for ADC channel availability on package variants.

# dsPIC33CK256MP508 FAMILY

## REGISTER 13-23: ADIEL: ADC INTERRUPT ENABLE REGISTER LOW<sup>(1)</sup>

R/W-0	R/W-0	R/W-0	R/W-0	R/W-0	R/W-0	R/W-0	R/W-0
IE[15:8]							
bit 15				bit 8			

R/W-0	R/W-0	R/W-0	R/W-0	R/W-0	R/W-0	R/W-0	R/W-0
IE[7:0]							
bit 7				bit 0			

### Legend:

R = Readable bit                      W = Writable bit                      U = Unimplemented bit, read as '0'  
 -n = Value at POR                      '1' = Bit is set                      '0' = Bit is cleared                      x = Bit is unknown

bit 15-0                      **IE[15:0]:** Common Interrupt Enable bits  
    1 = Common and individual interrupts are enabled for the corresponding channel  
    0 = Common and individual interrupts are disabled for the corresponding channel

**Note 1:** Bit availability is dependent on the number of supported ADC channels. Refer to [Table 1](#) and [Table 2](#) for ADC channel availability on package variants.

## REGISTER 13-24: ADIEH: ADC INTERRUPT ENABLE REGISTER HIGH<sup>(1)</sup>

U-0	U-0	U-0	U-0	U-0	U-0	R/W-0	R/W-0
—	—	—	—	—	—	IE[25:24]	
bit 15						bit 8	

R/W-0	R/W-0	R/W-0	R/W-0	R/W-0	R/W-0	R/W-0	R/W-0
IE[23:16]							
bit 7				bit 0			

### Legend:

R = Readable bit                      W = Writable bit                      U = Unimplemented bit, read as '0'  
 -n = Value at POR                      '1' = Bit is set                      '0' = Bit is cleared                      x = Bit is unknown

bit 15-10                      **Unimplemented:** Read as '0'  
 bit 9-0                      **IE[25:16]:** Common Interrupt Enable bits  
    1 = Common and individual interrupts are enabled for the corresponding channel  
    0 = Common and individual interrupts are disabled for the corresponding channel

**Note 1:** Bit availability is dependent on the number of supported ADC channels. Refer to [Table 1](#) and [Table 2](#) for ADC channel availability on package variants.

# dsPIC33CK256MP508 FAMILY

## REGISTER 13-25: ADSTATL: ADC DATA READY STATUS REGISTER LOW<sup>(1)</sup>

HSC/R-0	HSC/R-0	HSC/R-0	HSC/R-0	HSC/R-0	HSC/R-0	HSC/R-0	HSC/R-0
AN[15:8]RDY							
bit 15							bit 8

HSC/R-0	HSC/R-0	HSC/R-0	HSC/R-0	HSC/R-0	HSC/R-0	HSC/R-0	HSC/R-0
AN[7:0]RDY							
bit 7							bit 0

<b>Legend:</b>	U = Unimplemented bit, read as '0'
R = Readable bit	W = Writable bit
-n = Value at POR	'1' = Bit is set
	'0' = Bit is cleared
	x = Bit is unknown

bit 15-0 **AN[15:0]RDY:** Common Interrupt Enable for Corresponding Analog Inputs bits  
 1 = Channel conversion result is ready in the corresponding ADCBUFx register  
 0 = Channel conversion result is not ready

**Note 1:** Bit availability is dependent on the number of supported ADC channels. Refer to [Table 1](#) and [Table 2](#) for ADC channel availability on package variants.

## REGISTER 13-26: ADSTATH: ADC DATA READY STATUS REGISTER HIGH<sup>(1)</sup>

U-0	U-0	U-0	U-0	U-0	U-0	HSC/R-0	HSC/R-0
—						AN[25:24]RDY	
bit 15							bit 8

HSC/R-0	HSC/R-0	HSC/R-0	HSC/R-0	HSC/R-0	HSC/R-0	HSC/R-0	HSC/R-0
AN[23:16]RDY							
bit 7							bit 0

<b>Legend:</b>	U = Unimplemented bit, read as '0'
R = Readable bit	W = Writable bit
-n = Value at POR	'1' = Bit is set
	'0' = Bit is cleared
	x = Bit is unknown

bit 15-10 **Unimplemented:** Read as '0'

bit 9-0 **AN[25:16]RDY:** Common Interrupt Enable for Corresponding Analog Inputs bits  
 1 = Channel conversion result is ready in the corresponding ADCBUFx register  
 0 = Channel conversion result is not ready

**Note 1:** Bit availability is dependent on the number of supported ADC channels. Refer to [Table 1](#) and [Table 2](#) for ADC channel availability on package variants.

# dsPIC33CK256MP508 FAMILY

## REGISTER 13-27: ADTRIGnL/ADTRIGnH: ADC CHANNEL TRIGGER n(x) SELECTION REGISTERS LOW AND HIGH (x = 0 TO 25; n = 0 TO 6)<sup>(1)</sup>

U-0	U-0	U-0	R/W-0	R/W-0	R/W-0	R/W-0	R/W-0
—	—	—	TRGSRC(x+1)4	TRGSRC(x+1)3	TRGSRC(x+1)2	TRGSRC(x+1)1	TRGSRC(x+1)0
bit 15							bit 8

U-0	U-0	U-0	R/W-0	R/W-0	R/W-0	R/W-0	R/W-0
—	—	—	TRGSRCx4	TRGSRCx3	TRGSRCx2	TRGSRCx1	TRGSRCx0
bit 7							bit 0

### Legend:

R = Readable bit	W = Writable bit	U = Unimplemented bit, read as '0'
-n = Value at POR	'1' = Bit is set	'0' = Bit is cleared
		x = Bit is unknown

bit 15-13 **Unimplemented:** Read as '0'

bit 12-8 **TRGSRC(x+1)[4:0]:** Trigger Source Selection for Corresponding Analog Inputs bits (TRGSRC1 to TRGSRC25 – Odd)

11111 = ADTRG31 (PPS input)  
 11110 = PTG  
 11101 = CLC2  
 11100 = CLC1  
 11011 = Input Capture/Output Compare 9  
 11010 = Input Capture/Output Compare 7  
 11001 = Input Capture/Output Compare 6  
 11000 = Input Capture/Output Compare 5  
 10111 = Input Capture/Output Compare 4  
 10110 = Input Capture/Output Compare 3  
 10101 = Input Capture/Output Compare 2  
 10100 = Input Capture/Output Compare 1  
 10011 = PWM8 Trigger 2  
 10010 = PWM8 Trigger 1  
 10001 = PWM7 Trigger 2  
 10000 = PWM7 Trigger 1  
 01111 = PWM6 Trigger 2  
 01110 = PWM6 Trigger 1  
 01101 = PWM5 Trigger 2  
 01100 = PWM5 Trigger 1  
 01011 = PWM4 Trigger 2  
 01010 = PWM4 Trigger 1  
 01001 = PWM3 Trigger 2  
 01000 = PWM3 Trigger 1  
 00111 = PWM2 Trigger 2  
 00110 = PWM2 Trigger 1  
 00101 = PWM1 Trigger 2  
 00100 = PWM1 Trigger 1  
 00011 = Reserved  
 00010 = Level software trigger  
 00001 = Common software trigger  
 00000 = No trigger is enabled

bit 7-5 **Unimplemented:** Read as '0'

**Note 1:** The number of implemented registers is dependent on the number of available ADC channels. Refer to [Table 1](#) and [Table 2](#) for ADC channel availability of package variants.

# dsPIC33CK256MP508 FAMILY

## REGISTER 13-27: ADTRIGnL/ADTRIGnH: ADC CHANNEL TRIGGER n(x) SELECTION REGISTERS LOW AND HIGH (x = 0 TO 25; n = 0 TO 6)<sup>(1)</sup> (CONTINUED)

bit 4-0     **TRGSRCx[4:0]**: Common Interrupt Enable for Corresponding Analog Inputs bits (TRGSRC0 to TRGSRC24 – Even)

11111 = ADTRG31 (PPS input)  
11110 = PTG  
11101 = CLC2  
11100 = CLC1  
11011 = Input Capture/Output Compare 9  
11010 = Input Capture/Output Compare 7  
11001 = Input Capture/Output Compare 6  
11000 = Input Capture/Output Compare 5  
10111 = Input Capture/Output Compare 4  
10110 = Input Capture/Output Compare 3  
10101 = Input Capture/Output Compare 2  
10100 = Input Capture/Output Compare 1  
10011 = PWM8 Trigger 2  
10010 = PWM8 Trigger 1  
10001 = PWM7 Trigger 2  
10000 = PWM7 Trigger 1  
01111 = PWM6 Trigger 2  
01110 = PWM6 Trigger 1  
01101 = PWM5 Trigger 2  
01100 = PWM5 Trigger 1  
01011 = PWM4 Trigger 2  
01010 = PWM4 Trigger 1  
01001 = PWM3 Trigger 2  
01000 = PWM3 Trigger 1  
00111 = PWM2 Trigger 2  
00110 = PWM2 Trigger 1  
00101 = PWM1 Trigger 2  
00100 = PWM1 Trigger 1  
00011 = Reserved  
00010 = Level software trigger  
00001 = Common software trigger  
00000 = No trigger is enabled

**Note 1:** The number of implemented registers is dependent on the number of available ADC channels. Refer to [Table 1](#) and [Table 2](#) for ADC channel availability of package variants.

# dsPIC33CK256MP508 FAMILY

---

**TABLE 13-2: ADC CHANNEL TRIGGER SOURCE TO REGISTER ASSOCIATION**

Channel	Location
TRGSRC0	ADTRIG0L[4:0]
TRGSRC1	ADTRIG0L[12:8]
TRGSRC2	ADTRIG0H[4:0]
TRGSRC3	ADTRIG0H[12:8]
TRGSRC4	ADTRIG1L[4:0]
TRGSRC5	ADTRIG1L[12:8]
TRGSRC6	ADTRIG1H[4:0]
TRGSRC7	ADTRIG1H[12:8]
TRGSRC8	ADTRIG2L[4:0]
TRGSRC9	ADTRIG2L[12:8]
TRGSRC10	ADTRIG2H[4:0]
TRGSRC11	ADTRIG2H[12:8]
TRGSRC12	ADTRIG3L[4:0]
TRGSRC13	ADTRIG3L[12:8]
TRGSRC14	ADTRIG3H[4:0]
TRGSRC15	ADTRIG3H[12:8]
TRGSRC16	ADTRIG4L[4:0]
TRGSRC17	ADTRIG4L[12:8]
TRGSRC18	ADTRIG4H[4:0]
TRGSRC19	ADTRIG4H[12:8]
TRGSRC20	ADTRIG5L[4:0]
TRGSRC21	ADTRIG5L[12:8]
TRGSRC22	ADTRIG5H[4:0]
TRGSRC23	ADTRIG5H[12:8]
TRGSRC24	ADTRIG6L[4:0]
TRGSRC25	ADTRIG6L[12:8]

# dsPIC33CK256MP508 FAMILY

**REGISTER 13-28: ADCMPxCON: ADC DIGITAL COMPARATOR x CONTROL REGISTER (x = 0, 1, 2, 3)**

U-0	U-0	U-0	HSC/R-0	HSC/R-0	HSC/R-0	HSC/R-0	HSC/R-0
—	—	—	CHNL[4:0]				
bit 15							bit 8

R/W-0	R/W-0	HS/HC/R-0	R/W-0	R/W-0	R/W-0	R/W-0	R/W-0
CMPEN	IE	STAT	BTWN	HIHI	HILO	LOHI	LOLO
bit 7							bit 0

<b>Legend:</b>	HC = Hardware Clearable bit	U = Unimplemented bit, read as '0'
R = Readable bit	W = Writable bit	HSC = Hardware Settable/Clearable bit
-n = Value at POR	'1' = Bit is set	'0' = Bit is cleared
		HS = Hardware Settable bit

bit 15-13 **Unimplemented:** Read as '0'

bit 12-8 **CHNL[4:0]:** Input Channel Number bits

If the comparator has detected an event for a channel, this channel number is written to these bits.

11111 = Reserved

...

11010 = Reserved

11001 = Band gap, 1.2V (AN25)

11000 = Temperature sensor (AN24)

10111 = AN23

...

00011 = AN3

00010 = AN2

00001 = AN1

00000 = AN0

bit 7 **CMPEN:** Comparator Enable bit

1 = Comparator is enabled

0 = Comparator is disabled and the STAT status bit is cleared

bit 6 **IE:** Comparator Common ADC Interrupt Enable bit

1 = Common ADC interrupt will be generated if the comparator detects a comparison event instead of a digital comparator interrupt

0 = Common ADC interrupt will not be generated for the comparator

bit 5 **STAT:** Comparator Event Status bit

This bit is cleared by hardware when the channel number is read from the CHNL[4:0] bits.

1 = A comparison event has been detected since the last read of the CHNL[4:0] bits

0 = A comparison event has not been detected since the last read of the CHNL[4:0] bits

bit 4 **BTWN:** Between Low/High Comparator Event bit

1 = Generates a comparator event when  $ADCMPxLO \leq ADCBUFx < ADCMPxHI$

0 = Does not generate a digital comparator event when  $ADCMPxLO \leq ADCBUFx < ADCMPxHI$

bit 3 **HIHI:** High/High Comparator Event bit

1 = Generates a digital comparator event when  $ADCBUFx \geq ADCMPxHI$

0 = Does not generate a digital comparator event when  $ADCBUFx \geq ADCMPxHI$

bit 2 **HILO:** High/Low Comparator Event bit

1 = Generates a digital comparator event when  $ADCBUFx < ADCMPxHI$

0 = Does not generate a digital comparator event when  $ADCBUFx < ADCMPxHI$

bit 1 **LOHI:** Low/High Comparator Event bit

1 = Generates a digital comparator event when  $ADCBUFx \geq ADCMPxLO$

0 = Does not generate a digital comparator event when  $ADCBUFx \geq ADCMPxLO$

bit 0 **LOLO:** Low/Low Comparator Event bit

1 = Generates a digital comparator event when  $ADCBUFx < ADCMPxLO$

0 = Does not generate a digital comparator event when  $ADCBUFx < ADCMPxLO$

# dsPIC33CK256MP508 FAMILY

## REGISTER 13-29: ADCMP<sub>x</sub>ENL: ADC DIGITAL COMPARATOR x CHANNEL ENABLE REGISTER LOW (x = 0, 1, 2, 3)<sup>(1)</sup>

R/W-0	R/W-0	R/W-0	R/W-0	R/W-0	R/W-0	R/W-0	R/W-0
CMPEN[15:8]							
bit 15				bit 8			

R/W-0	R/W-0	R/W-0	R/W-0	R/W-0	R/W-0	R/W-0	R/W-0
CMPEN[7:0]							
bit 7				bit 0			

### Legend:

R = Readable bit                      W = Writable bit                      U = Unimplemented bit, read as '0'  
 -n = Value at POR                      '1' = Bit is set                      '0' = Bit is cleared                      x = Bit is unknown

bit 15-0                      **CMPEN[15:0]:** Comparator Enable for Corresponding Input Channels bits  
    1 = Conversion result for corresponding channel is used by the comparator  
    0 = Conversion result for corresponding channel is not used by the comparator

**Note 1:** Bit availability is dependent on the number of supported ADC channels. Refer to [Table 1](#) and [Table 2](#) for ADC channel availability on package variants.

## REGISTER 13-30: ADCMP<sub>x</sub>ENH: ADC DIGITAL COMPARATOR x CHANNEL ENABLE REGISTER HIGH (x = 0, 1, 2, 3)<sup>(1)</sup>

U-0	U-0	U-0	U-0	U-0	U-0	R/W-0	R/W-0
—						CMPEN[25:24]	
bit 15				bit 8			

R/W-0	R/W-0	R/W-0	R/W-0	R/W-0	R/W-0	R/W-0	R/W-0
CMPEN[23:16]							
bit 7				bit 0			

### Legend:

R = Readable bit                      W = Writable bit                      U = Unimplemented bit, read as '0'  
 -n = Value at POR                      '1' = Bit is set                      '0' = Bit is cleared                      x = Bit is unknown

bit 15-10                      **Unimplemented:** Read as '0'  
 bit 9-0                      **CMPEN[25:16]:** Comparator Enable for Corresponding Input Channels bits  
    1 = Conversion result for corresponding channel is used by the comparator  
    0 = Conversion result for corresponding channel is not used by the comparator

**Note 1:** Bit availability is dependent on the number of supported ADC channels. Refer to [Table 1](#) and [Table 2](#) for ADC channel availability on package variants.



# dsPIC33CK256MP508 FAMILY

## REGISTER 13-31: ADFLxCON: ADC DIGITAL FILTER x CONTROL REGISTER (x = 0, 1, 2, 3)

R/W-0	R/W-0	R/W-0	R/W-0	R/W-0	R/W-0	R/W-0	HSC/R-0
FLEN	MODE1	MODE0	OVRSAM2	OVRSAM1	OVRSAM0	IE	RDY
bit 15							bit 8

U-0	U-0	U-0	R/W-0	R/W-0	R/W-0	R/W-0	R/W-0	
—	—	—	FLCHSEL[4:0]				—	—
bit 7							bit 0	

<b>Legend:</b>	U = Unimplemented bit, read as '0'
R = Readable bit	W = Writable bit
-n = Value at POR	'1' = Bit is set
	'0' = Bit is cleared
	x = Bit is unknown
	HSC = Hardware Settable/Clearable bit

- bit 15     **FLEN:** Filter Enable bit  
           1 = Filter is enabled  
           0 = Filter is disabled and the RDY bit is cleared
- bit 14-13   **MODE[1:0]:** Filter Mode bits  
           11 = Averaging mode  
           10 = Reserved  
           01 = Reserved  
           00 = Oversampling mode
- bit 12-10   **OVRSAM[2:0]:** Filter Averaging/Oversampling Ratio bits  
           If MODE[1:0] = 00:  
           111 = 128x (16-bit result in the ADFLxDAT register is in 12.4 format)  
           110 = 32x (15-bit result in the ADFLxDAT register is in 12.3 format)  
           101 = 8x (14-bit result in the ADFLxDAT register is in 12.2 format)  
           100 = 2x (13-bit result in the ADFLxDAT register is in 12.1 format)  
           011 = 256x (16-bit result in the ADFLxDAT register is in 12.4 format)  
           010 = 64x (15-bit result in the ADFLxDAT register is in 12.3 format)  
           001 = 16x (14-bit result in the ADFLxDAT register is in 12.2 format)  
           000 = 4x (13-bit result in the ADFLxDAT register is in 12.1 format)  
           If MODE[1:0] = 11 (12-bit result in the ADFLxDAT register in all instances):  
           111 = 256x  
           110 = 128x  
           101 = 64x  
           100 = 32x  
           011 = 16x  
           110 = 8x  
           001 = 4x  
           000 = 2x
- bit 9       **IE:** Filter Interrupts Enable bit  
           1 = Individual and common interrupts will be generated when the filter result is ready  
           0 = Individual and common interrupts will not be generated for the filter
- bit 8       **RDY:** Oversampling Filter Data Ready Flag bit  
           This bit is cleared by hardware when the result is read from the ADFLxDAT register.  
           1 = Data in the ADFLxDAT register are ready  
           0 = The ADFLxDAT register has been read and new data in the ADFLxDAT register are not ready
- bit 7-5     **Unimplemented:** Read as '0'

# dsPIC33CK256MP508 FAMILY

---

## REGISTER 13-31: ADFLxCON: ADC DIGITAL FILTER x CONTROL REGISTER (x = 0, 1, 2, 3) (CONTINUED)

bit 4-0      **FLCHSEL[4:0]**: Oversampling Filter Input Channel Selection bits

- 11111 = Reserved
- ...
- 11010 = Reserved
- 11001 = Band gap, 1.2V (AN25)
- 11000 = Temperature sensor (AN24)
- 10111 = AN23
- ...
- 00011 = AN3
- 00010 = AN2
- 00001 = AN1
- 00000 = AN0

## 14.0 HIGH-SPEED ANALOG COMPARATOR WITH SLOPE COMPENSATION DAC

**Note 1:** This data sheet summarizes the features of the dsPIC33CK256MP508 family of devices. It is not intended to be a comprehensive reference source. To complement the information in this data sheet, refer to “**High-Speed Analog Comparator Module with Slope Compensation DAC**” ([www.microchip.com/DS70005280](http://www.microchip.com/DS70005280)) in the “dsPIC33/PIC24 Family Reference Manual”.

The high-speed analog comparator module provides a method to monitor voltage, current and other critical signals in a power conversion application that may be too fast for the CPU and ADC to capture. There are a total of 3 comparator modules. The analog comparator module can be used to implement Peak Current mode control, Critical Conduction mode (variable frequency) and Hysteretic Control mode.

### 14.1 Overview

The high-speed analog comparator module is comprised of a high-speed comparator, Pulse Density Modulation (PDM) DAC and a slope compensation unit. The slope compensation unit provides a user-defined slope which can be used to alter the DAC output. This feature is useful in applications, such as Peak Current mode control, where slope compensation is required to maintain the stability of the power supply. The user simply specifies the direction and rate of change for the slope compensation and the output of the DAC is modified accordingly.

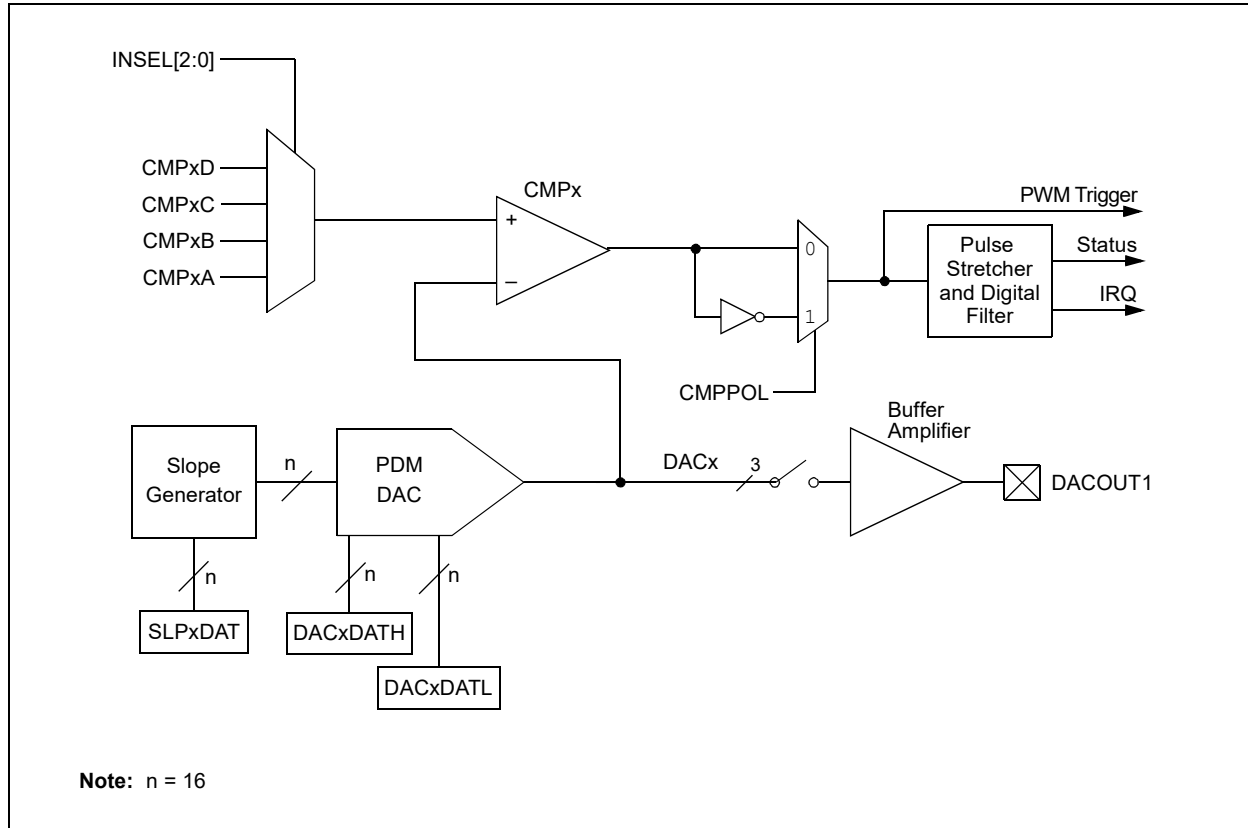
The DAC consists of a PDM unit, followed by a digitally controlled multiphase RC filter. The PDM unit uses a phase accumulator circuit to generate an output stream of pulses. The density of the pulse stream is proportional to the input data value, relative to the maximum value supported by the bit width of the accumulator. The output pulse density is representative of the desired output voltage. The pulse stream is filtered with an RC filter to yield an analog voltage. The output of the DAC is connected to the negative input of the comparator. The positive input of the comparator can be selected using a MUX from any of the input pins. The comparator provides a high-speed operation with a typical delay of 15 ns.

The output of the comparator is processed by the pulse stretcher and the digital filter blocks, which prevent comparator response to unintended fast transients in the inputs. [Figure 14-1](#) shows a block diagram of the high-speed analog comparator module. The DAC module can be operated in one of three modes: Slope Generation mode, Hysteretic mode and Triangle Wave mode. Each of these modes can be used in a variety of power supply applications.

**Note:** The DACOUT1 pin can only be associated with a single DAC output at any given time. If more than one DACOEN bit is set, the DACOUT1 pin will be a combination of the signals.

# dsPIC33CK256MP508 FAMILY

FIGURE 14-1: HIGH-SPEED ANALOG COMPARATOR MODULE BLOCK DIAGRAM



## 14.2 Features Overview

- Three Rail-to-Rail Analog Comparators
- Up to Four Selectable Input Sources per Comparator
- Programmable Comparator Hysteresis
- Programmable Output Polarity
- Interrupt Generation Capability
- Dedicated Pulse Density Modulation DAC for each Analog Comparator:
  - PDM unit followed by a digitally controlled multimode multipole RC filter
- Multimode Multipole RC Output Filter:
  - Transition mode: Provides the fastest response
  - Fast mode: For tracking DAC slopes
  - Steady-State mode: Provides 12-bit resolution
- Slope Compensation along with each DAC:
  - Slope Generation mode
  - Hysteretic Control mode
  - Triangle Wave mode
- Functional Support for the High-Speed PWM module which Includes:
  - PWM duty cycle control
  - PWM period control
  - PWM Fault detect

## 14.3 Control Registers

The DACCTRL1L and DACCTRL2H/L registers are common configuration registers for DAC modules.

The DACxCON, DACxDAT, SLPxCON and SLPxDAT registers specify the operation of individual modules.

# dsPIC33CK256MP508 FAMILY

## REGISTER 14-1: DACCTRL1L: DAC CONTROL 1 LOW REGISTER

R/W-0	U-0	R/W-0	U-0	U-0	U-0	U-0	U-0
DACON	—	DACSIDL	—	—	—	—	—
bit 15							bit 8

R/W-0	R/W-0	R/W-0	R/W-0	U-0	R/W-0	R/W-0	R/W-0
CLKSEL1 <sup>(1,3)</sup>	CLKSEL0 <sup>(1,3)</sup>	CLKDIV1 <sup>(1,3)</sup>	CLKDIV0 <sup>(1,3)</sup>	—	FCLKDIV2 <sup>(2)</sup>	FCLKDIV1 <sup>(2)</sup>	FCLKDIV0 <sup>(2)</sup>
bit 7							bit 0

### Legend:

R = Readable bit                      W = Writable bit                      U = Unimplemented bit, read as '0'  
 -n = Value at POR                      '1' = Bit is set                      '0' = Bit is cleared

- bit 15            **DACON:** Common DAC Module Enable bit  
                   1 = Enables DAC modules  
                   0 = Disables DAC modules and disables FSCM clocks to reduce power consumption; any pending Slope mode and/or underflow conditions are cleared
- bit 14            **Unimplemented:** Read as '0'
- bit 13            **DACSIDL:** DAC Stop in Idle Mode bit  
                   1 = Discontinues module operation when device enters Idle mode  
                   0 = Continues module operation in Idle mode
- bit 12-8         **Unimplemented:** Read as '0'
- bit 7-6          **CLKSEL[1:0]:** DAC Clock Source Select bits<sup>(1,3)</sup>  
                   11 = FPLLO  
                   10 = AFPLLO  
                   01 = FVCO/2  
                   00 = AFVCO/2
- bit 5-4          **CLKDIV[1:0]:** DAC Clock Divider bits<sup>(1,3)</sup>  
                   11 = Divide-by-4  
                   10 = Divide-by-3 (non-uniform duty cycle)  
                   01 = Divide-by-2  
                   00 = 1x
- bit 3             **Unimplemented:** Read as '0'
- bit 2-0          **FCLKDIV[2:0]:** Comparator Filter Clock Divider bits<sup>(2)</sup>  
                   111 = Divide-by-8  
                   110 = Divide-by-7  
                   101 = Divide-by-6  
                   100 = Divide-by-5  
                   011 = Divide-by-4  
                   010 = Divide-by-3  
                   001 = Divide-by-2  
                   000 = 1x

- Note 1:** These bits should only be changed when DACON = 0 to avoid unpredictable behavior.  
**Note 2:** The input clock to this divider is the selected clock input, CLKSEL[1:0], and then divided by two.  
**Note 3:** Clock source and dividers should yield an effective DAC clock input specified in [Table 33-40](#).

# dsPIC33CK256MP508 FAMILY

## REGISTER 14-2: DACCTRL2H: DAC CONTROL 2 HIGH REGISTER

U-0	U-0	U-0	U-0	U-0	U-0	R/W-0	R/W-0
—	—	—	—	—	—	SSTIME[9:8] <sup>(1,2)</sup>	
bit 15						bit 8	

R/W-1	R/W-0	R/W-0	R/W-0	R/W-1	R/W-0	R/W-1	R/W-0
SSTIME[7:0] <sup>(1,2)</sup>							
bit 7						bit 0	

**Legend:**

R = Readable bit                      W = Writable bit                      U = Unimplemented bit, read as '0'  
 -n = Value at POR                      '1' = Bit is set                      '0' = Bit is cleared

bit 15-10      **Unimplemented:** Read as '0'

bit 9-0      **SSTIME[9:0]:** Time from Start of Transition Mode until Steady-State Filter is Enabled bits<sup>(1,2)</sup>

**Note 1:** The value for SSTIME[9:0] should be greater than the TMODTIME[9:0] value.

**2:** The data value for this register should equal the time value specified by DA10 in Table 33-41 given the input clock frequency.

## REGISTER 14-3: DACCTRL2L: DAC CONTROL 2 LOW REGISTER

U-0	U-0	U-0	U-0	U-0	U-0	R/W-0	R/W-0
—	—	—	—	—	—	TMODTIME[9:8] <sup>(1,2)</sup>	
bit 15						bit 8	

R/W-0	R/W-1	R/W-0	R/W-1	R/W-0	R/W-1	R/W-0	R/W-1
TMODTIME[7:0] <sup>(1,2)</sup>							
bit 7						bit 0	

**Legend:**

R = Readable bit                      W = Writable bit                      U = Unimplemented bit, read as '0'  
 -n = Value at POR                      '1' = Bit is set                      '0' = Bit is cleared

bit 15-10      **Unimplemented:** Read as '0'

bit 9-0      **TMODTIME[9:0]:** Transition Mode Duration bits<sup>(1,2)</sup>

**Note 1:** The value for TMODTIME[9:0] should be less than the SSTIME[9:0] value.

**2:** The data value for this register should equal the time value specified by DA09 in Table 33-41 given the input clock frequency.

# dsPIC33CK256MP508 FAMILY

## REGISTER 14-4: DACxCONH: DACx CONTROL HIGH REGISTER

U-0	U-0	U-0	U-0	U-0	U-0	R/W-0	R/W-0
—	—	—	—	—	—	TMCB[9:8]	
bit 15						bit 8	

R/W-0	R/W-0	R/W-0	R/W-0	R/W-0	R/W-0	R/W-0	R/W-0
TMCB[7:0]							
bit 7							bit 0

### Legend:

R = Readable bit                      W = Writable bit                      U = Unimplemented bit, read as '0'  
 -n = Value at POR                      '1' = Bit is set                      '0' = Bit is cleared

bit 15-10      **Unimplemented:** Read as '0'

bit 9-0      **TMCB[9:0]:** DACx Leading-Edge Blanking bits

These register bits specify the blanking period for the comparator, following changes to the DAC output during Change-of-State (COS), for the input signal selected by the HCFSEL[3:0] bits in [Register 14-9](#).

## REGISTER 14-5: DACxCONL: DACx CONTROL LOW REGISTER

R/W-0	R/W-0	R/W-0	U-0	U-0	R/W-0	R/W-0	R/W-0
DACEN	IRQM1 <sup>(1,2)</sup>	IRQM0 <sup>(1,2)</sup>	—	—	CBE	DACOEN	FLTREN
bit 15							bit 8

R/W-0	R/W-0	R/W-0	R/W-0	R/W-0	R/W-0	R/W-0	R/W-0
CMPSTAT	CMPPOL	INSEL2	INSEL1	INSEL0	HYSPOL	HYSSEL1	HYSSEL0
bit 7							bit 0

### Legend:

R = Readable bit                      W = Writable bit                      U = Unimplemented bit, read as '0'  
 -n = Value at POR                      '1' = Bit is set                      '0' = Bit is cleared

bit 15      **DACEN:** Individual DACx Module Enable bit

1 = Enables DACx module

0 = Disables DACx module to reduce power consumption; any pending Slope mode and/or underflow conditions are cleared

bit 14-13      **IRQM[1:0]:** Interrupt Mode select bits<sup>(1,2)</sup>

11 = Generates an interrupt on either a rising or falling edge detect

10 = Generates an interrupt on a falling edge detect

01 = Generates an interrupt on a rising edge detect

00 = Interrupts are disabled

bit 12-11      **Unimplemented:** Read as '0'

**Note 1:** Changing these bits during operation may generate a spurious interrupt.

**2:** The edge selection is a post-polarity selection via the CMPPOL bit.



# dsPIC33CK256MP508 FAMILY

## REGISTER 14-5: DACxCONL: DACx CONTROL LOW REGISTER (CONTINUED)

- bit 10      **CBE:** Comparator Blank Enable bit  
1 = Enables the analog comparator output to be blanked (gated off) during the recovery transition following the completion of a slope operation  
0 = Disables the blanking signal to the analog comparator; therefore, the analog comparator output is always active
- bit 9      **DACOEN:** DACx Output Buffer Enable bit  
1 = DACx analog voltage is connected to the DACOUT1 pin  
0 = DACx analog voltage is not connected to the DACOUT1 pin
- bit 8      **FLTREN:** Comparator Digital Filter Enable bit  
1 = Digital filter is enabled  
0 = Digital filter is disabled
- bit 7      **CMPSTAT:** Comparator Status bits  
The current state of the comparator output including the CMPPOL selection.
- bit 6      **CMPPOL:** Comparator Output Polarity Control bit  
1 = Output is inverted  
0 = Output is noninverted
- bit 5-3    **INSEL[2:0]:** Comparator Input Source Select bits  
111 = Reserved  
110 = Reserved  
101 = Reserved  
100 = Reserved  
011 = CMPxD input pin  
010 = CMPxC input pin  
001 = CMPxB input pin  
000 = CMPxA input pin
- bit 2      **HYSPOL:** Comparator Hysteresis Polarity Select bit  
1 = Hysteresis is applied to the falling edge of the comparator output  
0 = Hysteresis is applied to the rising edge of the comparator output
- bit 1-0    **HYSSEL[1:0]:** Comparator Hysteresis Select bits  
11 = 45 mv hysteresis  
10 = 30 mv hysteresis  
01 = 15 mv hysteresis  
00 = No hysteresis is selected

**Note 1:** Changing these bits during operation may generate a spurious interrupt.

**2:** The edge selection is a post-polarity selection via the CMPPOL bit.

# dsPIC33CK256MP508 FAMILY

## REGISTER 14-6: DACxDATH: DACx DATA HIGH REGISTER

U-0	U-0	U-0	U-0	R/W-0	R/W-0	R/W-0	R/W-0
—	—	—	—	DACDAT[11:8]			
bit 15				bit 8			

R/W-0	R/W-0	R/W-0	R/W-0	R/W-0	R/W-0	R/W-0	R/W-0
DACDAT[7:0]							
bit 7				bit 0			

**Legend:**

R = Readable bit                      W = Writable bit                      U = Unimplemented bit, read as '0'  
 -n = Value at POR                      '1' = Bit is set                      '0' = Bit is cleared

bit 15-12     **Unimplemented:** Read as '0'  
 bit 11-0     **DACDAT[11:0]:** DACx Data bits  
 This register specifies the high DACx data value. Valid values are from 205 to 3890.

## REGISTER 14-7: DACxDATL: DACx DATA LOW REGISTER

U-0	U-0	U-0	U-0	R/W-0	R/W-0	R/W-0	R/W-0
—	—	—	—	DACLOW[11:8]			
bit 15				bit 8			

R/W-0	R/W-0	R/W-0	R/W-0	R/W-0	R/W-0	R/W-0	R/W-0
DACLOW[7:0]							
bit 7				bit 0			

**Legend:**

R = Readable bit                      W = Writable bit                      U = Unimplemented bit, read as '0'  
 -n = Value at POR                      '1' = Bit is set                      '0' = Bit is cleared

bit 15-12     **Unimplemented:** Read as '0'  
 bit 11-0     **DACLOW[11:0]:** DACx Low Data bits  
 In Hysteretic mode, Slope Generator mode and Triangle mode, this register specifies the low data value and/or limit for the DACx module. Valid values are from 205 to 3890.

# dsPIC33CK256MP508 FAMILY

## REGISTER 14-8: SLPxCONH: DACx SLOPE CONTROL HIGH REGISTER

R/W-0	U-0	U-0	U-0	R/W-0	R/W-0	R/W-0	U-0
SLOPEN	—	—	—	HME <sup>(1)</sup>	TWME <sup>(2)</sup>	PSE	—
bit 15							bit 8

U-0	U-0	U-0	U-0	U-0	U-0	U-0	U-0
—	—	—	—	—	—	—	—
bit 7							bit 0

### Legend:

R = Readable bit

W = Writable bit

U = Unimplemented bit, read as '0'

-n = Value at POR

'1' = Bit is set

'0' = Bit is cleared

- bit 15      **SLOPEN:** Slope Function Enable/On bit  
 1 = Enables slope function  
 0 = Disables slope function; slope accumulator is disabled to reduce power consumption
- bit 14-12    **Unimplemented:** Read as '0'
- bit 11      **HME:** Hysteretic Mode Enable bit<sup>(1)</sup>  
 1 = Enables Hysteretic mode for DACx  
 0 = Disables Hysteretic mode for DACx
- bit 10      **TWME:** Triangle Wave Mode Enable bit<sup>(2)</sup>  
 1 = Enables Triangle Wave mode for DACx  
 0 = Disables Triangle Wave mode for DACx
- bit 9        **PSE:** Positive Slope Mode Enable bit  
 1 = Slope mode is positive (increasing)  
 0 = Slope mode is negative (decreasing)
- bit 8-0     **Unimplemented:** Read as '0'

**Note 1:** HME mode requires the user to disable the slope function (SLOPEN = 0).

**2:** TWME mode requires the user to enable the slope function (SLOPEN = 1).

# dsPIC33CK256MP508 FAMILY

## REGISTER 14-9: SLPxCONL: DACx SLOPE CONTROL LOW REGISTER

R/W-0	R/W-0	R/W-0	R/W-0	R/W-0	R/W-0	R/W-0	R/W-0
HCFSEL3	HCFSEL2	HCFSEL1	HCFSEL0	SLPSTOPA3	SLPSTOPA2	SLPSTOPA1	SLPSTOPA0
bit 15							bit 8

R/W-0	R/W-0	R/W-0	R/W-0	R/W-0	R/W-0	R/W-0	R/W-0
SLPSTOPB3	SLPSTOPB2	SLPSTOPB1	SLPSTOPB0	SLPSTRT3	SLPSTRT2	SLPSTRT1	SLPSTRT0
bit 7							bit 0

### Legend:

R = Readable bit                      W = Writable bit                      U = Unimplemented bit, read as '0'  
 -n = Value at POR                      '1' = Bit is set0                      '0' = Bit is cleared

bit 15-12      **HCFSEL[3:0]:** Hysteretic Comparator Function Input Select bits

The selected input signal controls the switching between the DACx high limit (DACxDATH) and the DACx low limit (DACxDATL) as the data source for the PDM DAC. It modifies the polarity of the comparator, and the rising and falling edges initiate the start of the LEB counter (TMCB[9:0] bits in [Register 14-4](#)).

Input Selection	Source
1111	1
1100	0
1011	0
1010	0
1001	0
1000	PWM8H
0111	PWM7H
0110	PWM6H
0101	PWM5H
0100	PWM4H
0011	PWM3H
0010	PWM2H
0001	PWM1H
0000	0

# dsPIC33CK256MP508 FAMILY

## REGISTER 14-9: SLPxCONL: DACx SLOPE CONTROL LOW REGISTER (CONTINUED)

bit 11-8 **SLPSTOPA[3:0]:** Slope Stop A Signal Select bits

The selected Slope Stop A signal is logically OR'd with the selected Slope Stop B signal to terminate the slope function.

Slope Stop A Signal Selection	Source
1101-1111	1
1000	PWM8 Trigger 2
0111	PWM7 Trigger 2
0110	PWM6 Trigger 2
0101	PWM5 Trigger 2
0100	PWM4 Trigger 2
0011	PWM3 Trigger 2
0010	PWM2 Trigger 2
0001	PWM1 Trigger 2
0000	0

bit 7-4 **SLPSTOPB[3:0]:** Slope Stop B Signal Select bits

The selected Slope Stop B signal is logically OR'd with the selected Slope Stop A signal to terminate the slope function.

Slope Stop B Signal Selection	Source
0100-1111	1
0011	CMP3 Out
0010	CMP2 Out
0001	CMP1 Out
0000	0

bit 3-0 **SLPSTRT[3:0]:** Slope Start Signal Select bits

Slope Start Signal Selection	Source
1101-1111	1
1000	PWM8 Trigger 1
0111	PWM7 Trigger 1
0110	PWM6 Trigger 1
0101	PWM5 Trigger 1
0100	PWM4 Trigger 1
0011	PWM3 Trigger 1
0010	PWM2 Trigger 1
0001	PWM1 Trigger 1
0000	0

# dsPIC33CK256MP508 FAMILY

---

## REGISTER 14-10: SLPxDAT: DACx SLOPE DATA REGISTER<sup>(1)</sup>

R/W-0	R/W-0	R/W-0	R/W-0	R/W-0	R/W-0	R/W-0	R/W-0
SLPDAT[15:8]							
bit 15							bit 8

R/W-0	R/W-0	R/W-0	R/W-0	R/W-0	R/W-0	R/W-0	R/W-0
SLPDAT[7:0]							
bit 7							bit 0

### Legend:

R = Readable bit

W = Writable bit

U = Unimplemented bit, read as '0'

-n = Value at POR

'1' = Bit is set

'0' = Bit is cleared

bit 15-0      **SLPDAT[15:0]:** Slope Ramp Rate Value bits  
The SLPDATx value is in 12.4 format.

**Note 1:** Register data are left justified.

## 15.0 QUADRATURE ENCODER INTERFACE (QEI)

**Note 1:** This data sheet summarizes the features of the dsPIC33CK256MP508 family of devices. It is not intended to be a comprehensive resource. For more information, refer to “**Quadrature Encoder Interface (QEI)**” ([www.microchip.com/DS70000601](http://www.microchip.com/DS70000601)) in the “*dsPIC33/PIC24 Family Reference Manual*”.

The Quadrature Encoder Interface (QEI) module provides the interface to incremental encoders for obtaining mechanical position data. The dsPIC33CK256MP508 family implements two instances of the QEI. Quadrature Encoders, also known as incremental encoders or optical encoders, detect position and speed of rotating motion systems. Quadrature Encoders enable closed-loop control of motor control applications, such as Switched Reluctance (SR) and AC Induction Motors (ACIM).

A typical Quadrature Encoder includes a slotted wheel attached to the shaft of the motor and an emitter/detector module that senses the slots in the wheel. Typically, three output channels, Phase A (QEAx),

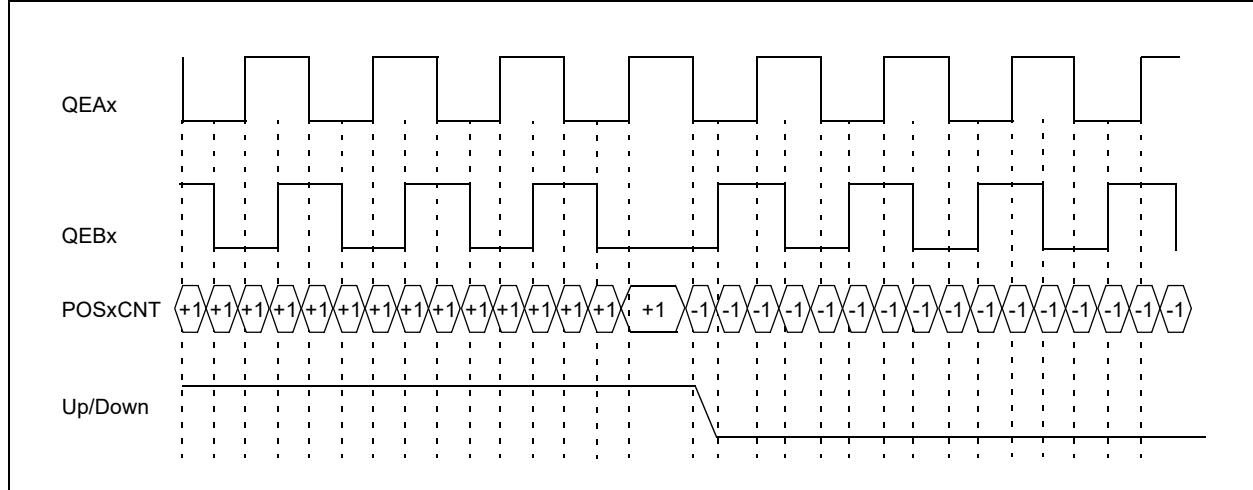
Phase B (QEBx) and Index (INDXx), provide information on the movement of the motor shaft, including distance and direction.

The two channels, Phase A (QEAx) and Phase B (QEBx), are typically 90 degrees out of phase with respect to each other. The Phase A and Phase B channels have a unique relationship. If Phase A leads Phase B, the direction of the motor is deemed positive or forward. If Phase A lags Phase B, the direction of the motor is deemed negative or reverse. The Index pulse occurs once per mechanical revolution and is used as a reference to indicate an absolute position. [Figure 15-1](#) illustrates the Quadrature Encoder Interface signals.

The Quadrature signals from the encoder can have four unique states ('01', '00', '10' and '11') that reflect the relationship between QEAx and QEBx. [Figure 15-1](#) illustrates these states for one count cycle. The order of the states get reversed when the direction of travel changes.

The Quadrature Decoder increments or decrements the 32-bit up/down Position x Counter (POSxCNTH/L) registers for each Change-of-State (COS). The counter increments when QEAx leads QEBx and decrements when QEBx leads QEAx.

**FIGURE 15-1: QUADRATURE ENCODER INTERFACE SIGNALS**



# dsPIC33CK256MP508 FAMILY

Table 15-1 shows the truth table that describes how the Quadrature signals are decoded.

**TABLE 15-1: TRUTH TABLE FOR QUADRATURE ENCODER**

Current Quadrature State		Previous Quadrature State		Action
QEA	QEB	QEA	QEB	
1	1	1	1	No count or direction change
1	1	1	0	Count up
1	1	0	1	Count down
1	1	0	0	Invalid state change; ignore
1	0	1	1	Count down
1	0	1	0	No count or direction change
1	0	0	1	Invalid state change; ignore
1	0	0	0	Count up
0	1	1	1	Count up
0	1	1	0	Invalid state change; ignore
0	1	0	1	No count or direction change
0	1	0	0	Count down
0	0	1	1	Invalid state change; ignore
0	0	1	0	Count down
0	0	0	1	Count up
0	0	0	0	No count or direction change

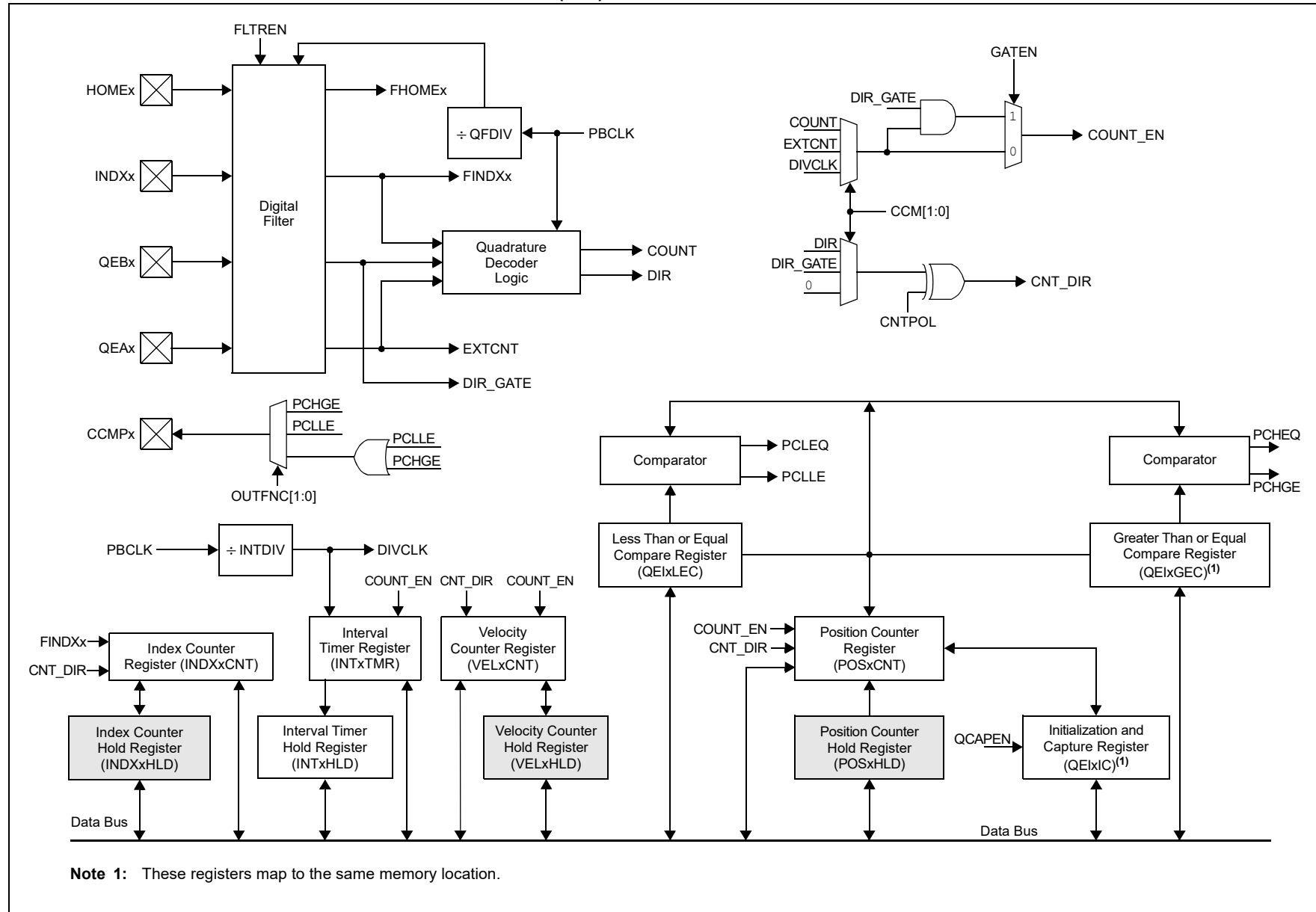
Figure 15-2 illustrates the simplified block diagram of the QEI module. The QEI module consists of decoder logic to interpret the Phase A (QEAx) and Phase B (QEBx) signals, and an up/down counter to accumulate the count. The counter pulses are generated when the Quadrature state changes. The count direction information must be maintained in a register until a direction change is detected. The module also includes digital noise filters, which condition the input signal.

The QEI module consists of the following major features:

- Four Input Pins: Two Phase Signals, an Index Pulse and a Home Pulse
- Programmable Digital Noise Filters on Inputs
- Quadrature Decoder providing Counter Pulses and Count Direction
- Count Direction Status
- 4x Count Resolution
- Index (INDXx) Pulse to Reset the Position Counter
- General Purpose 32-Bit Timer/Counter mode
- Interrupts generated by QEI or Counter Events
- 32-Bit Velocity Counter
- 32-Bit Position Counter
- 32-Bit Index Pulse Counter
- 32-Bit Interval Timer
- 32-Bit Position Initialization/Capture Register
- 32-Bit Compare Less Than and Greater Than Registers
- External Up/Down Count mode
- External Gated Count mode
- External Gated Timer mode
- Interval Timer mode



**FIGURE 15-2: QUADRATURE ENCODER INTERFACE (QEI) MODULE BLOCK DIAGRAM**



**Note 1:** These registers map to the same memory location.

# dsPIC33CK256MP508 FAMILY

## 15.1 QEI Control and Status Registers

### REGISTER 15-1: QEIXCON: QEIX CONTROL REGISTER

R/W-0	U-0	R/W-0	R/W-0	R/W-0	R/W-0	R/W-0	R/W-0
QEIEN	—	QEISIDL	PIMOD2 <sup>(1,5)</sup>	PIMOD1 <sup>(1,5)</sup>	PIMOD0 <sup>(1,5)</sup>	IMV1 <sup>(2)</sup>	IMV0 <sup>(2)</sup>
bit 15							bit 8

U-0	R/W-0	R/W-0	R/W-0	R/W-0	R/W-0	R/W-0	R/W-0
—	INTDIV2 <sup>(3)</sup>	INTDIV1 <sup>(3)</sup>	INTDIV0 <sup>(3)</sup>	CNTPOL	GATEN	CCM1	CCM0
bit 7							bit 0

#### Legend:

R = Readable bit                      W = Writable bit                      U = Unimplemented bit, read as '0'  
 -n = Value at POR                      '1' = Bit is set                      '0' = Bit is cleared                      x = Bit is unknown

- bit 15            **QEIEN:** Quadrature Encoder Interface Module Enable bit  
                   1 = Module counters are enabled  
                   0 = Module counters are disabled, but SFRs can be read or written
- bit 14            **Unimplemented:** Read as '0'
- bit 13            **QEISIDL:** QEI Stop in Idle Mode bit  
                   1 = Discontinues module operation when device enters Idle mode  
                   0 = Continues module operation in Idle mode
- bit 12-10       **PIMOD[2:0]:** Position Counter Initialization Mode Select bits<sup>(1,5)</sup>  
                   111 = Modulo Count mode for position counter and every Index event resets the position counter<sup>(4)</sup>  
                   110 = Modulo Count mode for position counter  
                   101 = Resets the position counter when the position counter equals the QEIXGEC register  
                   100 = Second Index event after Home event initializes position counter with contents of QEIXIC register  
                   011 = First Index event after Home event initializes position counter with contents of QEIXIC register  
                   010 = Next Index input event initializes the position counter with contents of QEIXIC register  
                   001 = Every Index input event resets the position counter  
                   000 = Index input event does not affect the position counter
- bit 9-8           **IMV[1:0]:** Index Match Value bits<sup>(2)</sup>  
                   11 = Index match occurs when QEBx = 1 and QEAX = 1  
                   10 = Index match occurs when QEBx = 1 and QEAX = 0  
                   01 = Index match occurs when QEBx = 0 and QEAX = 1  
                   00 = Index match occurs when QEBx = 0 and QEAX = 0
- bit 7            **Unimplemented:** Read as '0'

- Note 1:** When CCMx = 10 or CCMx = 11, all of the QEI counters operate as timers and the PIMOD[2:0] bits are ignored.
- 2:** When CCMx = 00, and QEAX and QEBx values match the Index Match Value (IMV), the POSxCNTH and POSxCNTL registers are reset.
- 3:** The selected clock rate should be at least twice the expected maximum quadrature count rate.
- 4:** Not all devices support this mode.
- 5:** The QCAPEN and HCAPEN bits must be cleared during PIMODx Modes 2 through 7 to ensure proper functionality. Not all devices support HCAPEN.

# dsPIC33CK256MP508 FAMILY

## REGISTER 15-1: QEIxCON: QEIx CONTROL REGISTER (CONTINUED)

- bit 6-4      **INTDIV[2:0]:** Timer Input Clock Prescale Select bits<sup>(3)</sup>  
(interval timer, main timer (position counter), velocity counter and Index counter internal clock divider select)
- 111 = 1:256 prescale value
  - 110 = 1:64 prescale value
  - 101 = 1:32 prescale value
  - 100 = 1:16 prescale value
  - 011 = 1:8 prescale value
  - 010 = 1:4 prescale value
  - 001 = 1:2 prescale value
  - 000 = 1:1 prescale value
- bit 3      **CNTPOL:** Position and Index Counter/Timer Direction Select bit
- 1 = Counter direction is negative unless modified by external up/down signal
  - 0 = Counter direction is positive unless modified by external up/down signal
- bit 2      **GATEN:** External Count Gate Enable bit
- 1 = External gate signal controls position counter operation
  - 0 = External gate signal does not affect position counter operation
- bit 1-0     **CCM[1:0]:** Counter Control Mode Selection bits
- 11 = Internal Timer mode
  - 10 = External Clock Count with External Gate mode
  - 01 = External Clock Count with External Up/Down mode
  - 00 = Quadrature Encoder mode

- Note 1:** When CCMx = 10 or CCMx = 11, all of the QEI counters operate as timers and the PIMOD[2:0] bits are ignored.
- 2:** When CCMx = 00, and QEAx and QEBx values match the Index Match Value (IMV), the POSxCNTH and POSxCNTL registers are reset.
- 3:** The selected clock rate should be at least twice the expected maximum quadrature count rate.
- 4:** Not all devices support this mode.
- 5:** The QCAPEN and HCAPEN bits must be cleared during PIMODx Modes 2 through 7 to ensure proper functionality. Not all devices support HCAPEN.

# dsPIC33CK256MP508 FAMILY

## REGISTER 15-2: QEIxIOC: QEIx I/O CONTROL REGISTER

R/W-0	R/W-0	R/W-0	R/W-0	R/W-0	R/W-0	R/W-0	R/W-0
QCAPEN	FLTREN	QFDIV2	QFDIV1	QFDIV0	OUTFNC1	OUTFNC0	SWPAB
bit 15						bit 8	

R/W-0	R/W-0	R/W-0	R/W-0	R-x	R-x	R-x	R-x
HOMPOL	IDXPOL	QEBPOL	QEAPOL	HOME	INDEX	QEB	QEA
bit 7						bit 0	

### Legend:

R = Readable bit                      W = Writable bit                      U = Unimplemented bit, read as '0'  
 -n = Value at POR                      '1' = Bit is set                      '0' = Bit is cleared                      x = Bit is unknown

- bit 15            **QCAPEN:** QEIx Position Counter Input Capture by Index Event Enable bit  
 1 = Index match event (positive edge) triggers a position capture event  
 0 = Index match event (positive edge) does not trigger a position capture event
- bit 14            **FLTREN:** QEAx/QEBx/INDXx/HOMEx Digital Filter Enable bit  
 1 = Input pin digital filter is enabled  
 0 = Input pin digital filter is disabled (bypassed)
- bit 13-11        **QFDIV[2:0]:** QEAx/QEBx/INDXx/HOMEx Digital Input Filter Clock Divide Select bits  
 111 = 1:256 clock divide  
 110 = 1:64 clock divide  
 101 = 1:32 clock divide  
 100 = 1:16 clock divide  
 011 = 1:8 clock divide  
 010 = 1:4 clock divide  
 001 = 1:2 clock divide  
 000 = 1:1 clock divide
- bit 10-9         **OUTFNC[1:0]:** QEIx Module Output Function Mode Select bits  
 11 = The QEICMPx pin goes high when POSxCNT ≤ QEIxLEC or POSxCNT ≥ QEIxGEC  
 10 = The QEICMPx pin goes high when POSxCNT ≤ QEIxLEC  
 01 = The QEICMPx pin goes high when POSxCNT ≥ QEIxGEC  
 00 = Output is disabled
- bit 8            **SWPAB:** Swap QEAx and QEBx Inputs bit  
 1 = QEAx and QEBx are swapped prior to Quadrature Decoder logic  
 0 = QEAx and QEBx are not swapped
- bit 7            **HOMPOL:** HOMEx Input Polarity Select bit  
 1 = Input is inverted  
 0 = Input is not inverted
- bit 6            **IDXPOL:** INDXx Input Polarity Select bit  
 1 = Input is inverted  
 0 = Input is not inverted
- bit 5            **QEBPOL:** QEBx Input Polarity Select bit  
 1 = Input is inverted  
 0 = Input is not inverted
- bit 4            **QEAPOL:** QEAx Input Polarity Select bit  
 1 = Input is inverted  
 0 = Input is not inverted
- bit 3            **HOME:** Status of HOMEx Input Pin After Polarity Control bit (read-only)  
 1 = Pin is at logic '1' if the HOMPOL bit is set to '0'; pin is at logic '0' if the HOMPOL bit is set to '1'  
 0 = Pin is at logic '0' if the HOMPOL bit is set to '0'; pin is at logic '1' if the HOMPOL bit is set to '1'

# dsPIC33CK256MP508 FAMILY

## REGISTER 15-2: QEIXIOC: QEIX I/O CONTROL REGISTER (CONTINUED)

- bit 2      **INDEX:** Status of INDXx Input Pin After Polarity Control bit (read-only)  
 1 = Pin is at logic '1' if the IDXPOL bit is set to '0'; pin is at logic '0' if the IDXPOL bit is set to '1'  
 0 = Pin is at logic '0' if the IDXPOL bit is set to '0'; pin is at logic '1' if the IDXPOL bit is set to '1'
- bit 1      **QEB:** Status of QEBx Input Pin After Polarity Control and SWPAB Pin Swapping bit (read-only)  
 1 = Physical pin, QEBx, is at logic '1' if the QEBPOL bit is set to '0' and the SWPAB bit is set to '0';  
       physical pin, QEBx, is at logic '0' if the QEBPOL bit is set to '1' and the SWPAB bit is set to '0';  
       physical pin, QEAx, is at logic '1' if the QEBPOL bit is set to '0' and the SWPAB bit is set to '1';  
       physical pin, QEAx, is at logic '0' if the QEBPOL bit is set to '1' and the SWPAB bit is set to '1';  
 0 = Physical pin, QEBx, is at logic '0' if the QEBPOL bit is set to '0' and the SWPAB bit is set to '0';  
       physical pin, QEBx, is at logic '1' if the QEBPOL bit is set to '1' and the SWPAB bit is set to '0';  
       physical pin, QEAx, is at logic '0' if the QEBPOL bit is set to '0' and the SWPAB bit is set to '1';  
       physical pin, QEAx, is at logic '1' if the QEBPOL bit is set to '1' and the SWPAB bit is set to '1'
- bit 0      **QEA:** Status of QEAx Input Pin After Polarity Control and SWPAB Pin Swapping bit (read-only)  
 1 = Physical pin, QEAx, is at logic '1' if the QEAPOL bit is set to '0' and the SWPAB bit is set to '0';  
       physical pin, QEAx, is at logic '0' if the QEAPOL bit is set to '1' and the SWPAB bit is set to '0';  
       physical pin, QEBx, is at logic '1' if the QEAPOL bit is set to '0' and the SWPAB bit is set to '1';  
       physical pin, QEBx, is at logic '0' if the QEAPOL bit is set to '1' and the SWPAB bit is set to '1';  
 0 = Physical pin, QEAx, is at logic '0' if the QEAPOL bit is set to '0' and the SWPAB bit is set to '0';  
       physical pin, QEAx, is at logic '1' if the QEAPOL bit is set to '1' and the SWPAB bit is set to '0';  
       physical pin, QEBx, is at logic '0' if the QEAPOL bit is set to '0' and the SWPAB bit is set to '1';  
       physical pin, QEBx, is at logic '1' if the QEAPOL bit is set to '1' and the SWPAB bit is set to '1'

## REGISTER 15-3: QEIXIOCH: QEIX I/O CONTROL HIGH REGISTER<sup>(1)</sup>

U-0	U-0	U-0	U-0	U-0	U-0	U-0	U-0
—	—	—	—	—	—	—	—
bit 15							bit 8

U-0	U-0	U-0	U-0	U-0	U-0	U-0	R/W-0
—	—	—	—	—	—	—	HCAPEN
bit 7							bit 0

### Legend:

R = Readable bit	W = Writable bit	U = Unimplemented bit, read as '0'
-n = Value at POR	'1' = Bit is set	'0' = Bit is cleared      x = Bit is unknown

bit 15-1      **Unimplemented:** Read as '0'

bit 0      **HCAPEN:** Position Counter Input Capture by Home Event Enable bit  
 1 = HOMEx input event (positive edge) triggers a position capture event  
 0 = HOMEx input event (positive edge) does not trigger a position capture event

**Note 1:** This register is not present on all devices.

# dsPIC33CK256MP508 FAMILY

## REGISTER 15-4: QEIXSTAT: QEIX STATUS REGISTER

U-0	U-0	HS/R/C-0	R/W-0	HS/R/C-0	R/W-0	HS/R/C-0	R/W-0
—	—	PCHEQIRQ	PCHEQIEN	PCLEQIRQ	PCLEQIEN	POSOVIRQ	POSOVIEN
bit 15						bit 8	

HS/R/C-0	R/W-0	HS/R/C-0	R/W-0	HS/R/C-0	R/W-0	HS/R/C-0	R/W-0
PCIIRQ <sup>(1)</sup>	PCIEN	VELOVIRQ	VELOVIEN	HOMIRQ	HOMIEN	IDXIRQ	IDXIEN
bit 7						bit 0	

<b>Legend:</b>	C = Clearable bit	HS = Hardware Settable bit
R = Readable bit	W = Writable bit	U = Unimplemented bit, read as '0'
-n = Value at POR	'1' = Bit is set	'0' = Bit is cleared      x = Bit is unknown

- bit 15-14      **Unimplemented:** Read as '0'
- bit 13      **PCHEQIRQ:** Position Counter Greater Than Compare Status bit  
                  1 = POSxCNT ≥ QEIXGEC  
                  0 = POSxCNT < QEIXGEC
- bit 12      **PCHEQIEN:** Position Counter Greater Than Compare Interrupt Enable bit  
                  1 = Interrupt is enabled  
                  0 = Interrupt is disabled
- bit 11      **PCLEQIRQ:** Position Counter Less Than Compare Status bit  
                  1 = POSxCNT ≤ QEIXLEC  
                  0 = POSxCNT > QEIXLEC
- bit 10      **PCLEQIEN:** Position Counter Less Than Compare Interrupt Enable bit  
                  1 = Interrupt is enabled  
                  0 = Interrupt is disabled
- bit 9      **POSOVIRQ:** Position Counter Overflow Status bit  
                  1 = Overflow has occurred  
                  0 = No overflow has occurred
- bit 8      **POSOVIEN:** Position Counter Overflow Interrupt Enable bit  
                  1 = Interrupt is enabled  
                  0 = Interrupt is disabled
- bit 7      **PCIIRQ:** Position Counter (Homing) Initialization Process Complete Status bit<sup>(1)</sup>  
                  1 = POSxCNT was reinitialized  
                  0 = POSxCNT was not reinitialized
- bit 6      **PCIEN:** Position Counter (Homing) Initialization Process Complete Interrupt Enable bit  
                  1 = Interrupt is enabled  
                  0 = Interrupt is disabled
- bit 5      **VELOVIRQ:** Velocity Counter Overflow Status bit  
                  1 = Overflow has occurred  
                  0 = No overflow has occurred
- bit 4      **VELOVIEN:** Velocity Counter Overflow Interrupt Enable bit  
                  1 = Interrupt is enabled  
                  0 = Interrupt is disabled
- bit 3      **HOMIRQ:** Status Flag for Home Event Status bit  
                  1 = Home event has occurred  
                  0 = No Home event has occurred

**Note 1:** This status bit is only applicable to PIMOD[2:0] modes, '011' and '100'.

# dsPIC33CK256MP508 FAMILY

---

## REGISTER 15-4: QEIxSTAT: QEIx STATUS REGISTER (CONTINUED)

- bit 2      **HOMIEN:** Home Input Event Interrupt Enable bit  
            1 = Interrupt is enabled  
            0 = Interrupt is disabled
- bit 1      **IDXIRQ:** Status Flag for Index Event Status bit  
            1 = Index event has occurred  
            0 = No Index event has occurred
- bit 0      **IDXIEN:** Index Input Event Interrupt Enable bit  
            1 = Interrupt is enabled  
            0 = Interrupt is disabled

**Note 1:** This status bit is only applicable to PIMOD[2:0] modes, '011' and '100'.

# dsPIC33CK256MP508 FAMILY

## REGISTER 15-5: POSxCNTL: POSITION x COUNTER REGISTER LOW

R/W-0	R/W-0	R/W-0	R/W-0	R/W-0	R/W-0	R/W-0	R/W-0
POSCNT[15:8]							
bit 15				bit 8			

R/W-0	R/W-0	R/W-0	R/W-0	R/W-0	R/W-0	R/W-0	R/W-0
POSCNT[7:0]							
bit 7				bit 0			

**Legend:**

R = Readable bit                      W = Writable bit                      U = Unimplemented bit, read as '0'  
 -n = Value at POR                      '1' = Bit is set                      '0' = Bit is cleared                      x = Bit is unknown

bit 15-0                      **POSCNT[15:0]:** Low Word Used to Form 32-Bit Position Counter Register (POSxCNT) bits

## REGISTER 15-6: POSxCNTH: POSITION x COUNTER REGISTER HIGH

R/W-0	R/W-0	R/W-0	R/W-0	R/W-0	R/W-0	R/W-0	R/W-0
POSCNT[31:24]							
bit 15				bit 8			

R/W-0	R/W-0	R/W-0	R/W-0	R/W-0	R/W-0	R/W-0	R/W-0
POSCNT[23:16]							
bit 7				bit 0			

**Legend:**

R = Readable bit                      W = Writable bit                      U = Unimplemented bit, read as '0'  
 -n = Value at POR                      '1' = Bit is set                      '0' = Bit is cleared                      x = Bit is unknown

bit 15-0                      **POSCNT[31:16]:** High Word Used to Form 32-Bit Position Counter Register (POSxCNT) bits



# dsPIC33CK256MP508 FAMILY

## REGISTER 15-7: POSxHLD: POSITION x COUNTER HOLD REGISTER

R/W-0	R/W-0	R/W-0	R/W-0	R/W-0	R/W-0	R/W-0	R/W-0
POSHLD[15:8]							
bit 15							
bit 8							

R/W-0	R/W-0	R/W-0	R/W-0	R/W-0	R/W-0	R/W-0	R/W-0
POSHLD[7:0]							
bit 7							
bit 0							

### Legend:

R = Readable bit

W = Writable bit

U = Unimplemented bit, read as '0'

-n = Value at POR

'1' = Bit is set

'0' = Bit is cleared

x = Bit is unknown

bit 15-0     **POSHLD[15:0]:** Hold Register for Reading/Writing Position x Counter High Word Register (POSxCNTH) (POSxCNT[31:16]) bits

# dsPIC33CK256MP508 FAMILY

## REGISTER 15-8: VELxCNT: VELOCITY x COUNTER REGISTER

R/W-0	R/W-0	R/W-0	R/W-0	R/W-0	R/W-0	R/W-0	R/W-0
VELCNT[15:8]							
bit 15				bit 8			

R/W-0	R/W-0	R/W-0	R/W-0	R/W-0	R/W-0	R/W-0	R/W-0
VELCNT[7:0]							
bit 7				bit 0			

### Legend:

R = Readable bit

W = Writable bit

U = Unimplemented bit, read as '0'

-n = Value at POR

'1' = Bit is set

'0' = Bit is cleared

x = Bit is unknown

bit 15-0      **VELCNT[15:0]**: Velocity Counter bits

## REGISTER 15-9: VELxCNTH: VELOCITY x COUNTER REGISTER HIGH<sup>(1)</sup>

R/W-0	R/W-0	R/W-0	R/W-0	R/W-0	R/W-0	R/W-0	R/W-0
VELCNT[31:24]							
bit 15				bit 8			

R/W-0	R/W-0	R/W-0	R/W-0	R/W-0	R/W-0	R/W-0	R/W-0
VELCNT[23:16]							
bit 7				bit 0			

### Legend:

R = Readable bit

W = Writable bit

U = Unimplemented bit, read as '0'

-n = Value at POR

'1' = Bit is set

'0' = Bit is cleared

x = Bit is unknown

bit 15-0      **VELCNT[31:16]**: Velocity Counter bits

**Note 1:** This register is not present on all devices.

# dsPIC33CK256MP508 FAMILY

## REGISTER 15-10: VELxHLD: VELOCITY x COUNTER HOLD REGISTER<sup>(1)</sup>

R/W-0	R/W-0	R/W-0	R/W-0	R/W-0	R/W-0	R/W-0	R/W-0
VELHLD[15:8]							
bit 15				bit 8			
R/W-0	R/W-0	R/W-0	R/W-0	R/W-0	R/W-0	R/W-0	R/W-0
VELHLD[7:0]							
bit 7				bit 0			

### Legend:

R = Readable bit

W = Writable bit

U = Unimplemented bit, read as '0'

-n = Value at POR

'1' = Bit is set

'0' = Bit is cleared

x = Bit is unknown

bit 15-0      **VELHLD[15:0]:** Hold for Reading/Writing Velocity Counter Register (VELxCNT[31:16]) bits

**Note 1:** This register is not present on all devices.

# dsPIC33CK256MP508 FAMILY

## REGISTER 15-11: INTxTMRL: INTERVAL x TIMER REGISTER LOW

R/W-0	R/W-0	R/W-0	R/W-0	R/W-0	R/W-0	R/W-0	R/W-0
INTTMR[15:8]							
bit 15				bit 8			

R/W-0	R/W-0	R/W-0	R/W-0	R/W-0	R/W-0	R/W-0	R/W-0
INTTMR[7:0]							
bit 7				bit 0			

**Legend:**

R = Readable bit                      W = Writable bit                      U = Unimplemented bit, read as '0'  
 -n = Value at POR                      '1' = Bit is set                      '0' = Bit is cleared                      x = Bit is unknown

bit 15-0                      **INTTMR[15:0]:** Low Word Used to Form 32-Bit Interval Timer Register (INTxTMR) bits

## REGISTER 15-12: INTxTMRH: INTERVAL x TIMER REGISTER HIGH

R/W-0	R/W-0	R/W-0	R/W-0	R/W-0	R/W-0	R/W-0	R/W-0
INTTMR[31:24]							
bit 15				bit 8			

R/W-0	R/W-0	R/W-0	R/W-0	R/W-0	R/W-0	R/W-0	R/W-0
INTTMR[23:16]							
bit 7				bit 0			

**Legend:**

R = Readable bit                      W = Writable bit                      U = Unimplemented bit, read as '0'  
 -n = Value at POR                      '1' = Bit is set                      '0' = Bit is cleared                      x = Bit is unknown

bit 15-0                      **INTTMR[31:16]:** High Word Used to Form 32-Bit Interval Timer Register (INTxTMR) bits

# dsPIC33CK256MP508 FAMILY

## REGISTER 15-13: INTxHLDL: INTERVAL x TIMER HOLD REGISTER LOW

R/W-0	R/W-0	R/W-0	R/W-0	R/W-0	R/W-0	R/W-0	R/W-0
INTHLD[15:8]							
bit 15							
bit 8							

R/W-0	R/W-0	R/W-0	R/W-0	R/W-0	R/W-0	R/W-0	R/W-0
INTHLD[7:0]							
bit 7							
bit 0							

**Legend:**

R = Readable bit                      W = Writable bit                      U = Unimplemented bit, read as '0'  
 -n = Value at POR                      '1' = Bit is set                      '0' = Bit is cleared                      x = Bit is unknown

bit 15-0                      **INTHLD[15:0]:** Low Word Used to Form 32-Bit Interval Timer Hold Register (INTxHLD) bits

## REGISTER 15-14: INTxHLDH: INTERVAL x TIMER HOLD REGISTER HIGH

R/W-0	R/W-0	R/W-0	R/W-0	R/W-0	R/W-0	R/W-0	R/W-0
INTHLD[31:24]							
bit 15							
bit 8							

R/W-0	R/W-0	R/W-0	R/W-0	R/W-0	R/W-0	R/W-0	R/W-0
INTHLD[23:16]							
bit 7							
bit 0							

**Legend:**

R = Readable bit                      W = Writable bit                      U = Unimplemented bit, read as '0'  
 -n = Value at POR                      '1' = Bit is set                      '0' = Bit is cleared                      x = Bit is unknown

bit 15-0                      **INTHLD[31:16]:** High Word Used to Form 32-Bit Interval Timer Hold Register (INTxHLD) bits

# dsPIC33CK256MP508 FAMILY

## REGISTER 15-15: INDXxCNTL: INDEX x COUNTER REGISTER LOW

R/W-0	R/W-0	R/W-0	R/W-0	R/W-0	R/W-0	R/W-0	R/W-0
INDXCNT[15:8]							
bit 15				bit 8			

R/W-0	R/W-0	R/W-0	R/W-0	R/W-0	R/W-0	R/W-0	R/W-0
INDXCNT[7:0]							
bit 7				bit 0			

**Legend:**

R = Readable bit                      W = Writable bit                      U = Unimplemented bit, read as '0'  
 -n = Value at POR                      '1' = Bit is set                      '0' = Bit is cleared                      x = Bit is unknown

bit 15-0                      **INDXCNT[15:0]:** Low Word Used to Form 32-Bit Index x Counter Register (INDXxCNT) bits

## REGISTER 15-16: INDXxCNTH: INDEX x COUNTER REGISTER HIGH

R/W-0	R/W-0	R/W-0	R/W-0	R/W-0	R/W-0	R/W-0	R/W-0
INDXCNT[31:24]							
bit 15				bit 8			

R/W-0	R/W-0	R/W-0	R/W-0	R/W-0	R/W-0	R/W-0	R/W-0
INDXCNT[23:16]							
bit 7				bit 0			

**Legend:**

R = Readable bit                      W = Writable bit                      U = Unimplemented bit, read as '0'  
 -n = Value at POR                      '1' = Bit is set                      '0' = Bit is cleared                      x = Bit is unknown

bit 15-0                      **INDXCNT[31:16]:** High Word Used to Form 32-Bit Index x Counter Register (INDXxCNT) bits

# dsPIC33CK256MP508 FAMILY

## REGISTER 15-17: INDXxHLD: INDEX x COUNTER HOLD REGISTER

R/W-0	R/W-0	R/W-0	R/W-0	R/W-0	R/W-0	R/W-0	R/W-0
INDXHLD[15:8]							
bit 15							
bit 8							

R/W-0	R/W-0	R/W-0	R/W-0	R/W-0	R/W-0	R/W-0	R/W-0
INDXHLD[7:0]							
bit 7							
bit 0							

### Legend:

R = Readable bit

W = Writable bit

U = Unimplemented bit, read as '0'

-n = Value at POR

'1' = Bit is set

'0' = Bit is cleared

x = Bit is unknown

bit 15-0     **INDXHLD[15:0]:** Hold Register for Reading/Writing Index x Counter High Word Register (INDXxCNTH[31:16]) bits

# dsPIC33CK256MP508 FAMILY

## REGISTER 15-18: QEIXICL: QEIX INITIALIZATION/CAPTURE REGISTER LOW

R/W-0	R/W-0	R/W-0	R/W-0	R/W-0	R/W-0	R/W-0	R/W-0
QEIIC[15:8]							
bit 15							bit 8

R/W-0	R/W-0	R/W-0	R/W-0	R/W-0	R/W-0	R/W-0	R/W-0
QEIIC[7:0]							
bit 7							bit 0

**Legend:**

R = Readable bit	W = Writable bit	U = Unimplemented bit, read as '0'
-n = Value at POR	'1' = Bit is set	'0' = Bit is cleared      x = Bit is unknown

bit 15-0      **QEIIC[15:0]:** Low Word Used to Form 32-Bit Initialization/Capture Register (QEIXIC) bits

## REGISTER 15-19: QEIXICH: QEIX INITIALIZATION/CAPTURE REGISTER HIGH

R/W-0	R/W-0	R/W-0	R/W-0	R/W-0	R/W-0	R/W-0	R/W-0
QEIIC[31:24]							
bit 15							bit 8

R/W-0	R/W-0	R/W-0	R/W-0	R/W-0	R/W-0	R/W-0	R/W-0
QEIIC[23:16]							
bit 7							bit 0

**Legend:**

R = Readable bit	W = Writable bit	U = Unimplemented bit, read as '0'
-n = Value at POR	'1' = Bit is set	'0' = Bit is cleared      x = Bit is unknown

bit 15-0      **QEIIC[31:16]:** High Word Used to Form 32-Bit Initialization/Capture Register (QEIXIC) bits



# dsPIC33CK256MP508 FAMILY

## REGISTER 15-20: QEIxLECL: QEIx LESS THAN OR EQUAL COMPARE REGISTER LOW

R/W-0	R/W-0	R/W-0	R/W-0	R/W-0	R/W-0	R/W-0	R/W-0
QEILEC[15:8]							
bit 15				bit 8			

R/W-0	R/W-0	R/W-0	R/W-0	R/W-0	R/W-0	R/W-0	R/W-0
QEILEC[7:0]							
bit 7				bit 0			

**Legend:**

R = Readable bit                      W = Writable bit                      U = Unimplemented bit, read as '0'  
 -n = Value at POR                      '1' = Bit is set                      '0' = Bit is cleared                      x = Bit is unknown

bit 15-0                      **QEILEC[15:0]:** Low Word Used to Form 32-Bit Less Than or Equal Compare Register (QEIxLEC) bits

## REGISTER 15-21: QEIxLECH: QEIx LESS THAN OR EQUAL COMPARE REGISTER HIGH

R/W-0	R/W-0	R/W-0	R/W-0	R/W-0	R/W-0	R/W-0	R/W-0
QEILEC[31:24]							
bit 15				bit 8			

R/W-0	R/W-0	R/W-0	R/W-0	R/W-0	R/W-0	R/W-0	R/W-0
QEILEC[23:16]							
bit 7				bit 0			

**Legend:**

R = Readable bit                      W = Writable bit                      U = Unimplemented bit, read as '0'  
 -n = Value at POR                      '1' = Bit is set                      '0' = Bit is cleared                      x = Bit is unknown

bit 15-0                      **QEILEC[31:16]:** High Word Used to Form 32-Bit Less Than or Equal Compare Register (QEIxLEC) bits

# dsPIC33CK256MP508 FAMILY

## REGISTER 15-22: QEIxGECL: QEIx GREATER THAN OR EQUAL COMPARE REGISTER LOW

R/W-0	R/W-0	R/W-0	R/W-0	R/W-0	R/W-0	R/W-0	R/W-0
QEIGEC[15:8]							
bit 15				bit 8			

R/W-0	R/W-0	R/W-0	R/W-0	R/W-0	R/W-0	R/W-0	R/W-0
QEIGEC[7:0]							
bit 7				bit 0			

**Legend:**

R = Readable bit                      W = Writable bit                      U = Unimplemented bit, read as '0'  
 -n = Value at POR                      '1' = Bit is set                      '0' = Bit is cleared                      x = Bit is unknown

bit 15-0                      **QEIGEC[15:0]:** Low Word Used to Form 32-Bit Greater Than or Equal Compare Register (QEIxGEC) bits

## REGISTER 15-23: QEIxGECH: QEIx GREATER THAN OR EQUAL COMPARE REGISTER HIGH

R/W-0	R/W-0	R/W-0	R/W-0	R/W-0	R/W-0	R/W-0	R/W-0
QEIGEC[31:24]							
bit 15				bit 8			

R/W-0	R/W-0	R/W-0	R/W-0	R/W-0	R/W-0	R/W-0	R/W-0
QEIGEC[23:16]							
bit 7				bit 0			

**Legend:**

R = Readable bit                      W = Writable bit                      U = Unimplemented bit, read as '0'  
 -n = Value at POR                      '1' = Bit is set                      '0' = Bit is cleared                      x = Bit is unknown

bit 15-0                      **QEIGEC[31:16]:** High Word Used to Form 32-Bit Greater Than or Equal Compare Register (QEIxGEC) bits

## 16.0 UNIVERSAL ASYNCHRONOUS RECEIVER TRANSMITTER (UART)

**Note 1:** This data sheet summarizes the features of the dsPIC33CK256MP508 family of devices. It is not intended to be a comprehensive reference source. To complement the information in this data sheet, refer to “**Multiprotocol Universal Asynchronous Receiver Transmitter (UART) Module**” ([www.microchip.com/DS70005288](http://www.microchip.com/DS70005288)) in the “*dsPIC33/PIC24 Family Reference Manual*”.

The Universal Asynchronous Receiver Transmitter (UART) is a flexible serial communication peripheral used to interface dsPIC<sup>®</sup> microcontrollers with other equipment, including computers and peripherals. The UART is a full-duplex, asynchronous communication channel that can be used to implement protocols, such as RS-232 and RS-485. The UART also supports the following hardware extensions:

- LIN/J2602
- IrDA<sup>®</sup>
- Digital Multiplex (DMX)
- Smart Card

The primary features of the UART are:

- Full or Half-Duplex Operation
- Up to 8-Deep TX and RX First In, First Out (FIFO) Buffers
- 8-Bit or 9-Bit Data Width
- Configurable Stop Bit Length
- Flow Control
- Auto-Baud Calibration
- Parity, Framing and Buffer Overrun Error Detection
- Address Detect
- Break Transmission
- Transmit and Receive Polarity Control
- Manchester Encoder/Decoder
- Operation in Sleep mode
- Wake from Sleep on Sync Break Received Interrupt

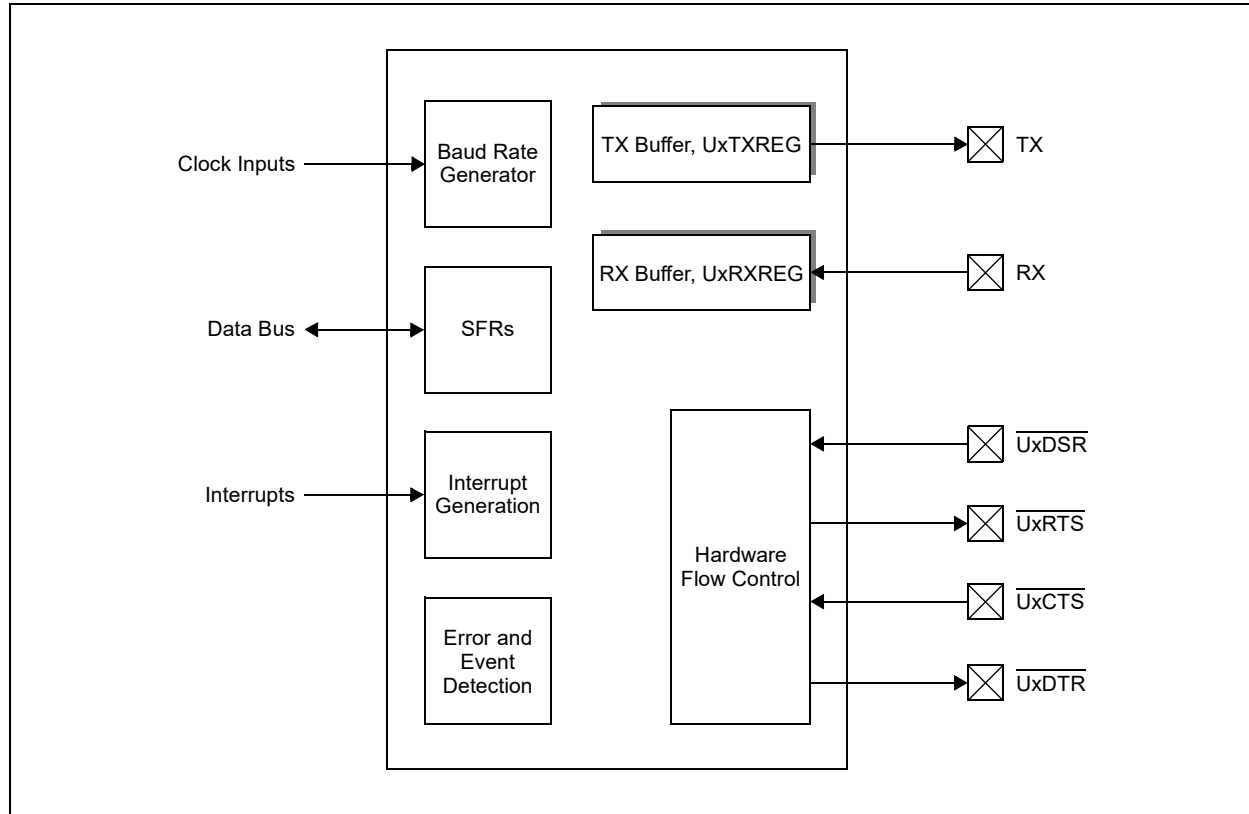
# dsPIC33CK256MP508 FAMILY

## 16.1 Architectural Overview

The UART transfers bytes of data, to and from device pins, using First-In First-Out (FIFO) buffers up to eight bytes deep. The status of the buffers and data is made available to user software through Special Function

Registers (SFRs). The UART implements multiple interrupt channels for handling transmit, receive and error events. A simplified block diagram of the UART is shown in [Figure 16-1](#).

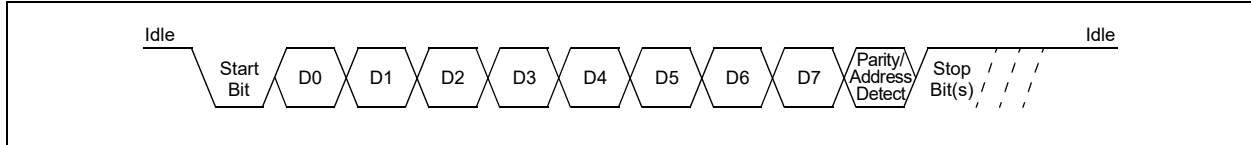
**FIGURE 16-1: SIMPLIFIED UARTx BLOCK DIAGRAM**



## 16.2 Character Frame

A typical UART character frame is shown in [Figure 16-2](#). The Idle state is high with a 'Start' condition indicated by a falling edge. The Start bit is followed by the number of data, parity/address detect and Stop bits defined by the MOD[3:0] (UxMODE[3:0]) bits selected.

**FIGURE 16-2: UART CHARACTER FRAME**



## 16.3 Data Buffers

Both transmit and receive functions use buffers to store data shifted to/from the pins. These buffers are FIFOs and are accessed by reading the SFRs, UxTXREG and UxRXREG, respectively. Each data buffer has multiple flags associated with its operation to allow software to read the status. Interrupts can also be configured based on the space available in the buffers. The transmit and receive buffers can be cleared and their pointers reset using the associated TX/RX Buffer Empty Status bits, UTXBE (UxSTAH[5]) and URXBE (UxSTAH[1]).

## 16.4 Protocol Extensions

The UART provides hardware support for LIN/J2602, IrDA<sup>®</sup>, DMX and smart card protocol extensions to reduce software overhead. A protocol extension is enabled by writing a value to the MOD[3:0] (UxMODE[3:0]) selection bits and further configured using the UARTx Timing Parameter registers, UxP1 ([Register 16-9](#)), UxP2 ([Register 16-10](#)), UxP3 ([Register 16-11](#)) and UxP3H ([Register 16-12](#)). Details regarding operation and usage are discussed in their respective chapters. Not all protocols are available on all devices. Please refer to the specific device data sheet for availability.

# dsPIC33CK256MP508 FAMILY

## 16.5 UART Control Registers

**REGISTER 16-1: UxMODE: UARTx CONFIGURATION REGISTER**

R/W-0	U-0	R/W-0	R/W-0	R/W-0	U-0	R/W-0	HC/R/W-0 <sup>(1)</sup>
UARTEN	—	USIDL	WAKE	RXBIMD	—	BRKOVr	UTXBRK
bit 15							bit 8

R/W-0	HC/R/W-0	R/W-0	R/W-0	R/W-0	R/W-0	R/W-0	R/W-0
BRGH	ABAUD	UTXEN	URXEN	MOD3	MOD2	MOD1	MOD0
bit 7							bit 0

<b>Legend:</b>	HC = Hardware Clearable bit	HS = Hardware Settable bit
R = Readable bit	W = Writable bit	U = Unimplemented bit, read as '0'
-n = Value at POR	'1' = Bit is set	'0' = Bit is cleared
		x = Bit is unknown

- bit 15      **UARTEN:** UART Enable bit  
 1 = UART is ready to transmit and receive  
 0 = UART state machine, FIFO Buffer Pointers and counters are reset; registers are readable and writable
- bit 14      **Unimplemented:** Read as '0'
- bit 13      **USIDL:** UART Stop in Idle Mode bit  
 1 = Discontinues module operation when device enters Idle mode  
 0 = Continues module operation in Idle mode
- bit 12      **WAKE:** Wake-up Enable bit  
 1 = Module will continue to sample the RX pin – interrupt generated on falling edge, bit cleared in hardware on following rising edge; if ABAUD is set, Auto-Baud Detection (ABD) will begin immediately  
 0 = RX pin is not monitored nor rising edge detected
- bit 11      **RXBIMD:** Receive Break Interrupt Mode bit  
 1 = RXBKIF flag when a minimum of 23 (DMX)/11 (asynchronous or LIN/J2602) low bit periods are detected  
 0 = RXBKIF flag when the Break makes a low-to-high transition after being low for at least 23/11 bit periods
- bit 10      **Unimplemented:** Read as '0'
- bit 9        **BRKOVr:** Send Break Software Override bit  
Overrides the TX Data Line:  
 1 = Makes the TX line active (Output 0 when UTXINV = 0, Output 1 when UTXINV = 1)  
 0 = TX line is driven by the shifter
- bit 8        **UTXBRK:** UART Transmit Break bit<sup>(1)</sup>  
 1 = Sends Sync Break on next transmission; cleared by hardware upon completion  
 0 = Sync Break transmission is disabled or has completed
- bit 7        **BRGH:** High Baud Rate Select bit  
 1 = High Speed: Baud rate is baudclk/4  
 0 = Low Speed: Baud rate is baudclk/16
- bit 6        **ABAUD:** Auto-Baud Detect Enable bit (read-only when MOD[3:0] = 1xxx)  
 1 = Enables baud rate measurement on the next character – requires reception of a Sync field (55h); cleared in hardware upon completion  
 0 = Baud rate measurement is disabled or has completed

**Note 1:** R/HS/HC in DMX and LIN mode.

# dsPIC33CK256MP508 FAMILY

---

## REGISTER 16-1: UxMODE: UARTx CONFIGURATION REGISTER (CONTINUED)

- bit 5        **UTXEN:** UART Transmit Enable bit  
            1 = Transmit enabled – except during Auto-Baud Detection  
            0 = Transmit disabled – all transmit counters, pointers and state machines are reset; TX buffer is not flushed, status bits are not reset
- bit 4        **URXEN:** UART Receive Enable bit  
            1 = Receive enabled – except during Auto-Baud Detection  
            0 = Receive disabled – all receive counters, pointers and state machines are reset; RX buffer is not flushed, status bits are not reset
- bit 3-0      **MOD[3:0]:** UART Mode bits  
            Other = Reserved  
            1111 = Smart card  
            1110 = IrDA®  
            1101 = Reserved  
            1100 = LIN Commander/Responder  
            1011 = LIN Responder only  
            1010 = DMX  
            1001 = Reserved  
            1000 = Reserved  
            0111 = Reserved  
            0110 = Reserved  
            0101 = Reserved  
            0100 = Asynchronous 9-bit UART with address detect, ninth bit = 1 signals address  
            0011 = Asynchronous 8-bit UART without address detect, ninth bit is used as an even parity bit  
            0010 = Asynchronous 8-bit UART without address detect, ninth bit is used as an odd parity bit  
            0001 = Asynchronous 7-bit UART  
            0000 = Asynchronous 8-bit UART

**Note 1:** R/HS/HC in DMX and LIN mode.

# dsPIC33CK256MP508 FAMILY

## REGISTER 16-2: UxMODEH: UARTx CONFIGURATION REGISTER HIGH

R/W-0	R-0	U-0	U-0	R/W-0	R/W-0	R/W-0	R/W-0
SLPEN	ACTIVE	—	—	BCLKMOD	BCLKSEL1	BCLKSEL0	HALFDPLX
bit 15				bit 8			

R/W-0	R/W-0	R/W-0	R/W-0	R/W-0	R/W-0	R/W-0	R/W-0
RUNOVF	URXINV	STSEL1	STSEL0	C0EN	UTXINV	FLO1	FLO0
bit 7				bit 0			

### Legend:

R = Readable bit                      W = Writable bit                      U = Unimplemented bit, read as '0'  
-n = Value at POR                      '1' = Bit is set                      '0' = Bit is cleared                      x = Bit is unknown

- bit 15            **SLPEN:** Run During Sleep Enable bit  
1 = UART BRG clock runs during Sleep  
0 = UART BRG clock is turned off during Sleep
- bit 14            **ACTIVE:** UART Running Status bit  
1 = UART clock request is active (user can not update the UxMODE/UxMODEH registers)  
0 = UART clock request is not active (user can update the UxMODE/UxMODEH registers)
- bit 13-12        **Unimplemented:** Read as '0'
- bit 11            **BCLKMOD:** Baud Clock Generation Mode Select bit  
1 = Uses fractional Baud Rate Generation  
0 = Uses legacy divide-by-x counter for baud clock generation (x = 4 or 16 depending on the BRGH bit)
- bit 10-9         **BCLKSEL[1:0]:** Baud Clock Source Selection bits  
11 = AFVCO/3  
10 = FOSC  
01 = Reserved  
00 = FOSC/2 (Fp)
- bit 8             **HALFDPLX:** UART Half-Duplex Selection Mode bit  
1 = Half-Duplex mode: UxTX is driven as an output when transmitting and tri-stated when TX is Idle  
0 = Full-Duplex mode: UxTX is driven as an output at all times when both UxRTEN and UxTXEN are set
- bit 7             **RUNOVF:** Run During Overflow Condition Mode bit  
1 = When an Overflow Error (OERR) condition is detected, the RX shifter continues to run so as to remain synchronized with incoming RX data; data are not transferred to UxRXREG when it is full (i.e., no UxRXREG data are overwritten)  
0 = When an Overflow Error (OERR) condition is detected, the RX shifter stops accepting new data (Legacy mode)
- bit 6             **URXINV:** UART Receive Polarity bit  
1 = Inverts RX polarity; Idle state is low  
0 = Input is not inverted; Idle state is high
- bit 5-4          **STSEL[1:0]:** Number of Stop Bits Selection bits  
11 = 2 Stop bits sent, 1 checked at receive  
10 = 2 Stop bits sent, 2 checked at receive  
01 = 1.5 Stop bits sent, 1.5 checked at receive  
00 = 1 Stop bit sent, 1 checked at receive
- bit 3             **C0EN:** Enable Legacy Checksum (C0) Transmit and Receive bit  
1 = Checksum Mode 1 (enhanced LIN checksum in LIN mode; add all TX/RX words in all other modes)  
0 = Checksum Mode 0 (legacy LIN checksum in LIN mode; not used in all other modes)



# dsPIC33CK256MP508 FAMILY

---

## REGISTER 16-2: UxMODEH: UARTx CONFIGURATION REGISTER HIGH (CONTINUED)

- bit 2            **UTXINV:** UART Transmit Polarity bit  
1 = Inverts TX polarity; TX is low in Idle state  
0 = Output data are not inverted; TX output is high in Idle state
- bit 1-0        **FLO[1:0]:** Flow Control Enable bits (only valid when MOD[3:0] = 0xxxx)  
11 = Reserved  
10 =  $\overline{\text{RTS}}\text{-}\overline{\text{DSR}}$  (for TX side)/ $\overline{\text{CTS}}\text{-DTR}$  (for RX side) hardware flow control  
01 = XON/XOFF software flow control  
00 = Flow control off

# dsPIC33CK256MP508 FAMILY

## REGISTER 16-3: UxSTA: UARTx STATUS REGISTER

R/W-0	R/W-0	R/W-0	R/W-0	R/W-0	R/W-0	R/W-0	R/W-0
TXMTIE	PERIE	ABDOVE	CERIE	FERIE	RXBKIE	OERIE	TXCIE
bit 15							bit 8

R-1	R-0	HS/R/W-0	HS/R/W-0	R-0	HS/R/W-0	HS/R/W-0	HS/R/W-0
TRMT	PERR	ABDOVF	CERIF	FERR	RXBKIF	OERR	TXCIF
bit 7							bit 0

<b>Legend:</b>	HS = Hardware Settable bit		
R = Readable bit	W = Writable bit	U = Unimplemented bit, read as '0'	
-n = Value at POR	'1' = Bit is set	'0' = Bit is cleared	x = Bit is unknown

- bit 15      **TXMTIE:** Transmit Shifter Empty Interrupt Enable bit  
 1 = Interrupt is enabled  
 0 = Interrupt is disabled
- bit 14      **PERIE:** Parity Error Interrupt Enable bit  
 1 = Interrupt is enabled  
 0 = Interrupt is disabled
- bit 13      **ABDOVE:** Auto-Baud Rate Acquisition Interrupt Enable bit  
 1 = Interrupt is enabled  
 0 = Interrupt is disabled
- bit 12      **CERIE:** Checksum Error Interrupt Enable bit  
 1 = Interrupt is enabled  
 0 = Interrupt is disabled
- bit 11      **FERIE:** Framing Error Interrupt Enable bit  
 1 = Interrupt is enabled  
 0 = Interrupt is disabled
- bit 10      **RXBKIE:** Receive Break Interrupt Enable bit  
 1 = Interrupt is enabled  
 0 = Interrupt is disabled
- bit 9        **OERIE:** Receive Buffer Overflow Interrupt Enable bit  
 1 = Interrupt is enabled  
 0 = Interrupt is disabled
- bit 8        **TXCIE:** Transmit Collision Interrupt Enable bit  
 1 = Interrupt is enabled  
 0 = Interrupt is disabled
- bit 7        **TRMT:** Transmit Shifter Empty Interrupt Flag bit (read-only)  
 1 = Transmit Shift Register (TSR) is empty (end of last Stop bit when STPMD = 1 or middle of first Stop bit when STPMD = 0)  
 0 = Transmit Shift Register is not empty
- bit 6        **PERR:** Parity Error/Address Received/Forward Frame Interrupt Flag bit  
LIN and Parity Modes:  
 1 = Parity error detected  
 0 = No parity error detected  
Address Mode:  
 1 = Address received  
 0 = No address detected  
All Other Modes:  
 Not used.

# dsPIC33CK256MP508 FAMILY

---

## REGISTER 16-3: UxSTA: UARTx STATUS REGISTER (CONTINUED)

- bit 5      **ABDOVF**: Auto-Baud Rate Acquisition Interrupt Flag bit (must be cleared by software)  
          1 = BRG rolled over during the auto-baud rate acquisition sequence (must be cleared in software)  
          0 = BRG has not rolled over during the auto-baud rate acquisition sequence
- bit 4      **CERIF**: Checksum Error Interrupt Flag bit (must be cleared by software)  
          1 = Checksum error  
          0 = No checksum error
- bit 3      **FERR**: Framing Error Interrupt Flag bit  
          1 = Framing Error: Inverted level of the Stop bit corresponding to the topmost character in the buffer;  
              propagates through the buffer with the received character  
          0 = No framing error
- bit 2      **RXBKIF**: Receive Break Interrupt Flag bit (must be cleared by software)  
          1 = A Break was received  
          0 = No Break was detected
- bit 1      **OERR**: Receive Buffer Overflow Interrupt Flag bit (must be cleared by software)  
          1 = Receive buffer has overflowed  
          0 = Receive buffer has not overflowed
- bit 0      **TXCIF**: Transmit Collision Interrupt Flag bit (must be cleared by software)  
          1 = Transmitted word is not equal to the received word  
          0 = Transmitted word is equal to the received word

# dsPIC33CK256MP508 FAMILY

## REGISTER 16-4: UxSTAH: UARTx STATUS REGISTER HIGH

U-0	R/W-0	R/W-0	R/W-0	U-0	R/W-0	R/W-0	R/W-0
—	UTXISEL2	UTXISEL1	UTXISEL0	—	URXISEL2 <sup>(1)</sup>	URXISEL1 <sup>(1)</sup>	URXISEL0 <sup>(1)</sup>
bit 15				bit 8			

HS/R/W-0	R/W-0	R/S-1	R-0	R-1	R-1	R/S-1	R-0
TXWRE	STPMD	UTXBE	UTXBF	RIDLE	XON	URXBE	URXBF
bit 7							bit 0

<b>Legend:</b>	HS = Hardware Settable bit	S = Settable bit
R = Readable bit	W = Writable bit	U = Unimplemented bit, read as '0'
-n = Value at POR	'1' = Bit is set	'0' = Bit is cleared
		x = Bit is unknown

- bit 15      **Unimplemented:** Read as '0'
- bit 14-12    **UTXISEL[2:0]:** UART Transmit Interrupt Select bits
  - 111 = Sets transmit interrupt when there is one empty slot left in the buffer
  - ...
  - 010 = Sets transmit interrupt when there are six empty slots or more in the buffer
  - 001 = Sets transmit interrupt when there are seven empty slots or more in the buffer
  - 000 = Sets transmit interrupt when there are eight empty slots in the buffer; TX buffer is empty
- bit 11      **Unimplemented:** Read as '0'
- bit 10-8    **URXISEL[2:0]:** UART Receive Interrupt Select bits<sup>(1)</sup>
  - 111 = Triggers receive interrupt when there are eight words in the buffer; RX buffer is full
  - ...
  - 001 = Triggers receive interrupt when there are two words or more in the buffer
  - 000 = Triggers receive interrupt when there is one word or more in the buffer
- bit 7      **TXWRE:** TX Write Transmit Error Status bit
  - LIN and Parity Modes:
  - 1 = A new byte was written when the buffer was full or when P2[8:0] = 0 (must be cleared by software)
  - 0 = No error
  - Address Detect Mode:
  - 1 = A new byte was written when the buffer was full or to P1[8:0] when P1x was full (must be cleared by software)
  - 0 = No error
  - Other Modes:
  - 1 = A new byte was written when the buffer was full (must be cleared by software)
  - 0 = No error
- bit 6      **STPMD:** Stop Bit Detection Mode bit
  - 1 = Triggers RXIF at the end of the last Stop bit
  - 0 = Triggers RXIF in the middle of the first (or second, depending on the STSEL[1:0] setting) Stop bit
- bit 5      **UTXBE:** UART TX Buffer Empty Status bit
  - 1 = Transmit buffer is empty; writing '1' when UTXEN = 0 will reset the TX FIFO Pointers and counters
  - 0 = Transmit buffer is not empty
- bit 4      **UTXBF:** UART TX Buffer Full Status bit
  - 1 = Transmit buffer is full
  - 0 = Transmit buffer is not full
- bit 3      **RIDLE:** Receive Idle bit
  - 1 = UART RX line is in the Idle state
  - 0 = UART RX line is receiving something

**Note 1:** The receive watermark interrupt is not set if PERR or FERR is set and the corresponding IE bit is set.

# dsPIC33CK256MP508 FAMILY

---

## REGISTER 16-4: UxSTAH: UARTx STATUS REGISTER HIGH (CONTINUED)

- bit 2        **XON**: UART in XON Mode bit  
Only valid when FLO[1:0] control bits are set to XON/XOFF mode.  
1 = UART has received XON  
0 = UART has not received XON or XOFF was received
- bit 1        **URXBE**: UART RX Buffer Empty Status bit  
1 = Receive buffer is empty; writing '1' when URXEN = 0 will reset the RX FIFO Pointers and counters  
0 = Receive buffer is not empty
- bit 0        **URXBF**: UART RX Buffer Full Status bit  
1 = Receive buffer is full  
0 = Receive buffer is not full

**Note 1:** The receive watermark interrupt is not set if PERR or FERR is set and the corresponding IE bit is set.

# dsPIC33CK256MP508 FAMILY

## REGISTER 16-5: UxBRG: UARTx BAUD RATE REGISTER

R/W-0	R/W-0	R/W-0	R/W-0	R/W-0	R/W-0	R/W-0	R/W-0
BRG[15:8]							
bit 15							
bit 8							

R/W-0	R/W-0	R/W-0	R/W-0	R/W-0	R/W-0	R/W-0	R/W-0
BRG[7:0]							
bit 7							
bit 0							

**Legend:**

R = Readable bit                      W = Writable bit                      U = Unimplemented bit, read as '0'  
 -n = Value at POR                      '1' = Bit is set                      '0' = Bit is cleared                      x = Bit is unknown

bit 15                      **BRG[15:0]:** Baud Rate Divisor bits

## REGISTER 16-6: UxBRGH: UARTx BAUD RATE REGISTER HIGH

U-0	U-0	U-0	U-0	U-0	U-0	U-0	U-0
—	—	—	—	—	—	—	—
bit 15							
bit 8							

U-0	U-0	U-0	U-0	R/W-0	R/W-0	R/W-0	R/W-0
—	—	—	—	BRG[19:16]			
bit 7							
bit 0							

**Legend:**

R = Readable bit                      W = Writable bit                      U = Unimplemented bit, read as '0'  
 -n = Value at POR                      '1' = Bit is set                      '0' = Bit is cleared                      x = Bit is unknown

bit 15-4                      **Unimplemented:** Read as '0'  
 bit 3-0                      **BRG[19:16]:** Baud Rate Divisor bits

# dsPIC33CK256MP508 FAMILY

## REGISTER 16-7: UxRXREG: UARTx RECEIVE BUFFER REGISTER

U-0	U-0	U-0	U-0	U-0	U-0	U-0	U-0
—	—	—	—	—	—	—	—
bit 15							bit 8

R-x	R-x	R-x	R-x	R-x	R-x	R-x	R-x
RXREG[7:0]							
bit 7							bit 0

**Legend:**

R = Readable bit                      W = Writable bit                      U = Unimplemented bit, read as '0'  
 -n = Value at POR                      '1' = Bit is set                      '0' = Bit is cleared                      x = Bit is unknown

bit 15-8            **Unimplemented:** Read as '0'  
 bit 7-0            **RXREG[7:0]:** Received Character Data bits 7-0

## REGISTER 16-8: UxTXREG: UARTx TRANSMIT BUFFER REGISTER

W-x	U-0	U-0	U-0	U-0	U-0	U-0	U-0
LAST	—	—	—	—	—	—	—
bit 15							bit 8

W-x	W-x	W-x	W-x	W-x	W-x	W-x	W-x
TXREG[7:0]							
bit 7							bit 0

**Legend:**

R = Readable bit                      W = Writable bit                      U = Unimplemented bit, read as '0'  
 -n = Value at POR                      '1' = Bit is set                      '0' = Bit is cleared                      x = Bit is unknown

bit 15            **LAST:** Last Byte Indicator for Smart Card Support bit  
 bit 14-8        **Unimplemented:** Read as '0'  
 bit 7-0        **TXREG[7:0]:** Transmitted Character Data bits 7-0  
                   If the buffer is full, further writes to the buffer are ignored.

# dsPIC33CK256MP508 FAMILY

## REGISTER 16-9: UxP1: UARTx TIMING PARAMETER 1 REGISTER

U-0	U-0	U-0	U-0	U-0	U-0	U-0	R/W-0
—	—	—	—	—	—	—	P1[8]
bit 15							bit 8

R/W-0	R/W-0	R/W-0	R/W-0	R/W-0	R/W-0	R/W-0	R/W-0
P1[7:0]							
bit 7							bit 0

### Legend:

R = Readable bit                      W = Writable bit                      U = Unimplemented bit, read as '0'  
 -n = Value at POR                      '1' = Bit is set                      '0' = Bit is cleared                      x = Bit is unknown

bit 15-9                      **Unimplemented:** Read as '0'

bit 8-0                      **P1[8:0]:** Parameter 1 bits

DMX TX:

Number of Bytes to Transmit – 1 (not including Start code).

LIN Commander TX:

PID to transmit (bits[5:0]).

Asynchronous TX with Address Detect:

Address to transmit. A '1' is automatically inserted into bit 9 (bits[7:0]).

Smart Card Mode:

Guard Time Counter bits. This counter is operated on the bit clock whose period is always equal to one ETU (bits[8:0]).

Other Modes:

Not used.



# dsPIC33CK256MP508 FAMILY

## REGISTER 16-10: UxP2: UARTx TIMING PARAMETER 2 REGISTER

U-0	U-0	U-0	U-0	U-0	U-0	U-0	R/W-0
—	—	—	—	—	—	—	P2[8]
bit 15							bit 8

R/W-0	R/W-0	R/W-0	R/W-0	R/W-0	R/W-0	R/W-0	R/W-0
P2[7:0]							
bit 7							bit 0

### Legend:

R = Readable bit	W = Writable bit	U = Unimplemented bit, read as '0'
-n = Value at POR	'1' = Bit is set	'0' = Bit is cleared      x = Bit is unknown

bit 15-9      **Unimplemented:** Read as '0'

bit 8-0      **P2[8:0]:** Parameter 2 bits

#### DMX RX:

The first byte number to receive – 1, not including Start code (bits[8:0]).

#### LIN Responder TX:

Number of bytes to transmit (bits[7:0]).

#### Asynchronous RX with Address Detect:

Address to start matching (bits[7:0]).

#### Smart Card Mode:

Block Time Counter bits. This counter is operated on the bit clock whose period is always equal to one ETU (bits[8:0]).

#### Other Modes:

Not used.

# dsPIC33CK256MP508 FAMILY

## REGISTER 16-11: UxP3: UARTx TIMING PARAMETER 3 REGISTER

R/W-0	R/W-0	R/W-0	R/W-0	R/W-0	R/W-0	R/W-0	R/W-0
P3[15:8]							
bit 15							
bit 8							

R/W-0	R/W-0	R/W-0	R/W-0	R/W-0	R/W-0	R/W-0	R/W-0
P3[7:0]							
bit 7							
bit 0							

### Legend:

R = Readable bit                      W = Writable bit                      U = Unimplemented bit, read as '0'  
 -n = Value at POR                      '1' = Bit is set                      '0' = Bit is cleared                      x = Bit is unknown

bit 15-0      **P3[15:0]:** Parameter 3 bits  
DMX RX:  
 The last byte number to receive – 1, not including Start code (bits[8:0]).  
LIN Responder RX:  
 Number of bytes to receive (bits[7:0]).  
Asynchronous RX:  
 Used to mask the UxP2 address bits; 1 = P2 address bit is used, 0 = P2 address bit is masked off (bits[7:0]).  
Smart Card Mode:  
 Waiting Time Counter bits (bits[15:0]).  
Other Modes:  
 Not used.

## REGISTER 16-12: UxP3H: UARTx TIMING PARAMETER 3 REGISTER HIGH

U-0	U-0	U-0	U-0	U-0	U-0	U-0	U-0
—							
bit 15							
bit 8							

R/W-0	R/W-0	R/W-0	R/W-0	R/W-0	R/W-0	R/W-0	R/W-0
P3[23:16]							
bit 7							
bit 0							

### Legend:

R = Readable bit                      W = Writable bit                      U = Unimplemented bit, read as '0'  
 -n = Value at POR                      '1' = Bit is set                      '0' = Bit is cleared                      x = Bit is unknown

bit 15-8      **Unimplemented:** Read as '0'  
 bit 7-0      **P3[23:16]:** Parameter 3 High bits  
Smart Card Mode:  
 Waiting Time Counter bits (bits[23:16]).  
Other Modes:  
 Not used.

# dsPIC33CK256MP508 FAMILY

## REGISTER 16-13: UxTXCHK: UARTx TRANSMIT CHECKSUM REGISTER

U-0	U-0	U-0	U-0	U-0	U-0	U-0	U-0
—	—	—	—	—	—	—	—
bit 15							bit 8

R/W-0	R/W-0	R/W-0	R/W-0	R/W-0	R/W-0	R/W-0	R/W-0
TXCHK[7:0]							
bit 7							bit 0

### Legend:

R = Readable bit

W = Writable bit

U = Unimplemented bit, read as '0'

-n = Value at POR

'1' = Bit is set

'0' = Bit is cleared

x = Bit is unknown

bit 15-8 **Unimplemented:** Read as '0'

bit 7-0 **TXCHK[7:0]:** Transmit Checksum bits (calculated from TX words)

#### LIN Modes:

C0EN = 1: Sum of all transmitted data + addition carries, including PID.

C0EN = 0: Sum of all transmitted data + addition carries, excluding PID.

#### LIN Responder:

Cleared when Break is detected.

#### LIN Commander/Responder:

Cleared when Break is detected.

#### Other Modes:

C0EN = 1: Sum of every byte transmitted + addition carries.

C0EN = 0: Value remains unchanged.

# dsPIC33CK256MP508 FAMILY

## REGISTER 16-14: UxRXCHK: UARTx RECEIVE CHECKSUM REGISTER

U-0	U-0	U-0	U-0	U-0	U-0	U-0	U-0
—	—	—	—	—	—	—	—
bit 15							bit 8

R/W-0	R/W-0	R/W-0	R/W-0	R/W-0	R/W-0	R/W-0	R/W-0
RXCHK[7:0]							
bit 7							bit 0

### Legend:

R = Readable bit	W = Writable bit	U = Unimplemented bit, read as '0'
-n = Value at POR	'1' = Bit is set	'0' = Bit is cleared
		x = Bit is unknown

bit 15-8      **Unimplemented:** Read as '0'

bit 7-0      **RXCHK[7:0]:** Receive Checksum bits (calculated from RX words)

#### LIN Modes:

C0EN = 1: Sum of all received data + addition carries, including PID.

C0EN = 0: Sum of all received data + addition carries, excluding PID.

#### LIN Responder:

Cleared when Break is detected.

#### LIN Commander/Responder:

Cleared when Break is detected.

#### Other Modes:

C0EN = 1: Sum of every byte received + addition carries.

C0EN = 0: Value remains unchanged.

# dsPIC33CK256MP508 FAMILY

## REGISTER 16-15: UxSCCON: UARTx SMART CARD CONFIGURATION REGISTER

U-0	U-0	U-0	U-0	U-0	U-0	U-0	U-0
—	—	—	—	—	—	—	—
bit 15							bit 8

U-0	U-0	R/W-0	R/W-0	R/W-0	R/W-0	R/W-0	U-0
—	—	TXRPT1	TXRPT0	CONV	T0PD	PRTCL	—
bit 7							bit 0

### Legend:

R = Readable bit

W = Writable bit

U = Unimplemented bit, read as '0'

-n = Value at POR

'1' = Bit is set

'0' = Bit is cleared

x = Bit is unknown

- bit 15-6     **Unimplemented:** Read as '0'
- bit 5-4     **TXRPT[1:0]:** Transmit Repeat Selection bits  
             11 = Retransmits the error byte four times  
             10 = Retransmits the error byte three times  
             01 = Retransmits the error byte twice  
             00 = Retransmits the error byte once
- bit 3       **CONV:** Logic Convention Selection bit  
             1 = Inverse logic convention  
             0 = Direct logic convention
- bit 2       **T0PD:** Pull-Down Duration for T = 0 Error Handling bit  
             1 = Two ETU  
             0 = One ETU
- bit 1       **PRTCL:** Smart Card Protocol Selection bit  
             1 = T = 1  
             0 = T = 0
- bit 0       **Unimplemented:** Read as '0'

# dsPIC33CK256MP508 FAMILY

## REGISTER 16-16: UxSCINT: UARTx SMART CARD INTERRUPT REGISTER

U-0	U-0	HS/R/W-0	HS/R/W-0	U-0	HS/R/W-0	HS/R/W-0	HS/R/W-0
—	—	RXRPTIF	TXRPTIF	—	BTCIF	WTCIF	GTCIF
bit 15				bit 8			

U-0	U-0	R/W-0	R/W-0	U-0	R/W-0	R/W-0	R/W-0
—	—	RXRPTIE	TXRPTIE	—	BTCIE	WTCIE	GTCIE
bit 7				bit 0			

<b>Legend:</b>	HS = Hardware Settable bit		
R = Readable bit	W = Writable bit	U = Unimplemented bit, read as '0'	
-n = Value at POR	'1' = Bit is set	'0' = Bit is cleared	x = Bit is unknown

- bit 15-14     **Unimplemented:** Read as '0'
- bit 13       **RXRPTIF:** Receive Repeat Interrupt Flag bit  
 1 = Parity error has persisted after the same character has been received five times (four retransmits)  
 0 = Flag is cleared
- bit 12       **TXRPTIF:** Transmit Repeat Interrupt Flag bit  
 1 = Line error has been detected after the last retransmit per TXRPT[1:0]  
 0 = Flag is cleared
- bit 11       **Unimplemented:** Read as '0'
- bit 10       **BTCIF:** Block Time Counter Interrupt Flag bit  
 1 = Block Time Counter has reached 0  
 0 = Block Time Counter has not reached 0
- bit 9         **WTCIF:** Waiting Time Counter Interrupt Flag bit  
 1 = Waiting Time Counter has reached 0  
 0 = Waiting Time Counter has not reached 0
- bit 8         **GTCIF:** Guard Time Counter Interrupt Flag bit  
 1 = Guard Time Counter has reached 0  
 0 = Guard Time Counter has not reached 0
- bit 7-6      **Unimplemented:** Read as '0'
- bit 5         **RXRPTIE:** Receive Repeat Interrupt Enable bit  
 1 = An interrupt is invoked when a parity error has persisted after the same character has been received five times (four retransmits)  
 0 = Interrupt is disabled
- bit 4         **TXRPTIE:** Transmit Repeat Interrupt Enable bit  
 1 = An interrupt is invoked when a line error is detected after the last retransmit per TXRPT[1:0] has been completed  
 0 = Interrupt is disabled
- bit 3         **Unimplemented:** Read as '0'
- bit 2         **BTCIE:** Block Time Counter Interrupt Enable bit  
 1 = Block Time Counter interrupt is enabled  
 0 = Block Time Counter interrupt is disabled
- bit 1         **WTCIE:** Waiting Time Counter Interrupt Enable bit  
 1 = Waiting Time Counter interrupt is enabled  
 0 = Waiting Time Counter Interrupt is disabled
- bit 0         **GTCIE:** Guard Time Counter interrupt enable bit  
 1 = Guard Time Counter interrupt is enabled  
 0 = Guard Time Counter interrupt is disabled

# dsPIC33CK256MP508 FAMILY

## REGISTER 16-17: UxINT: UARTx INTERRUPT REGISTER

U-0	U-0	U-0	U-0	U-0	U-0	U-0	U-0
—	—	—	—	—	—	—	—
bit 15						bit 8	

HS/R/W-0	HS/R/W-0	U-0	U-0	U-0	R/W-0	U-0	U-0
WUIF	ABDIF	—	—	—	ABDIE	—	—
bit 7						bit 0	

<b>Legend:</b>	HS = Hardware Settable bit
R = Readable bit	W = Writable bit
-n = Value at POR	'1' = Bit is set
	'0' = Bit is cleared
	x = Bit is unknown

- bit 15-8     **Unimplemented:** Read as '0'
- bit 7       **WUIF:** Wake-up Interrupt Flag bit
  - 1 = Sets when WAKE = 1 and RX makes a '1'-to-'0' transition; triggers event interrupt (must be cleared by software)
  - 0 = WAKE is not enabled or WAKE is enabled, but no wake-up event has occurred
- bit 6       **ABDIF:** Auto-Baud Completed Interrupt Flag bit
  - 1 = Sets when ABD sequence makes the final '1'-to-'0' transition; triggers event interrupt (must be cleared by software)
  - 0 = ABAUD is not enabled or ABAUD is enabled but auto-baud has not completed
- bit 5-3     **Unimplemented:** Read as '0'
- bit 2       **ABDIE:** Auto-Baud Completed Interrupt Enable Flag bit
  - 1 = Allows ABDIF to set an event interrupt
  - 0 = ABDIF does not set an event interrupt
- bit 1-0     **Unimplemented:** Read as '0'

# dsPIC33CK256MP508 FAMILY

---

NOTES:



## 17.0 SERIAL PERIPHERAL INTERFACE (SPI)

**Note 1:** This data sheet summarizes the features of the dsPIC33CK256MP508 family of devices. It is not intended to be a comprehensive reference source. To complement the information in this data sheet, refer to “**Serial Peripheral Interface (SPI) with Audio Codec Support**” ([www.microchip.com/DS70005136](http://www.microchip.com/DS70005136)) in the “*dsPIC33/PIC24 Family Reference Manual*”.

The Serial Peripheral Interface (SPI) module is a synchronous serial interface, useful for communicating with other peripheral or microcontroller devices. These peripheral devices may be serial EEPROMs, shift registers, display drivers, A/D Converters, etc. The SPI module is compatible with the Motorola® SPI and SIOP interfaces. All devices in the dsPIC33CK256MP508 family include three SPI modules. On 48, 64 and 80-pin devices, SPI instance SPI2 can operate at higher speeds when selected as a non-PPS pin. The selection is done using the SPI2PIN bit (FDEVOP[13]). If the bit for SPI2PIN is '1', the PPS pin will be used. When SPI2PIN is '0', the SPI signals are routed to dedicated pins.

The module supports operation in two Buffer modes. In Standard mode, data are shifted through a single serial buffer. In Enhanced Buffer mode, data are shifted through a FIFO buffer. The FIFO level depends on the configured mode.

**Note:** FIFO depth for this device is four (in 8-Bit Data mode).

Variable length data can be transmitted and received, from 2 to 32 bits.

**Note:** Do not perform Read-Modify-Write operations (such as bit-oriented instructions) on the SPIxBUF register in either Standard or Enhanced Buffer mode.

The module also supports a basic framed SPI protocol while operating in either Host or Client mode. A total of four framed SPI configurations are supported.

The module also supports Audio modes. Four different Audio modes are available.

- I<sup>2</sup>S mode
- Left Justified mode
- Right Justified mode
- PCM/DSP mode

In each of these modes, the serial clock is free-running and audio data are always transferred.

If an audio protocol data transfer takes place between two devices, then usually one device is the Host and the other is the Client. However, audio data can be transferred between two Clients. Because the audio protocols require free-running clocks, the Host can be a third-party controller. In either case, the Host generates two free-running clocks: SCKx and LRC (Left, Right Channel Clock/ $\overline{SSx}$ /FSYNC).

The SPI serial interface consists of four pins:

- SDIx: Serial Data Input
- SDOx: Serial Data Output
- SCKx: Shift Clock Input or Output
- $\overline{SSx}$ : Active-Low Client Select or Frame Synchronization I/O Pulse

The SPI module can be configured to operate using two, three or four pins. In the 3-pin mode,  $\overline{SSx}$  is not used. In the 2-pin mode, both SDOx and  $\overline{SSx}$  are not used.

# dsPIC33CK256MP508 FAMILY

The SPI module has the ability to generate three interrupts reflecting the events that occur during the data communication. The following types of interrupts can be generated:

1. Receive interrupts are signalled by SPIxRXIF.  
This event occurs when:
  - RX watermark interrupt
  - SPIROV = 1
  - SPIRBF = 1
  - SPIRBE = 1provided the respective mask bits are enabled in SPIxIMSKL/H.
2. Transmit interrupts are signalled by SPIxTXIF.  
This event occurs when:
  - TX watermark interrupt
  - SPITUR = 1
  - SPITBF = 1
  - SPITBE = 1provided the respective mask bits are enabled in SPIxIMSKL/H.
3. General interrupts are signalled by SPIxGIF.  
This event occurs when:
  - FRMERR = 1
  - SPIBUSY = 1
  - SRMT = 1provided the respective mask bits are enabled in SPIxIMSKL/H.

Block diagrams of the module in Standard and Enhanced modes are shown in [Figure 17-1](#) and [Figure 17-2](#).

**Note:** In this section, the SPI modules are referred to together as SPIx, or separately as SPI1, SPI2 or SPI3. Special Function Registers will follow a similar notation. For example, SPIxCON1 and SPIxCON2 refer to the control registers for any of the three SPI modules.

To set up the SPIx module for the Standard Host mode of operation:

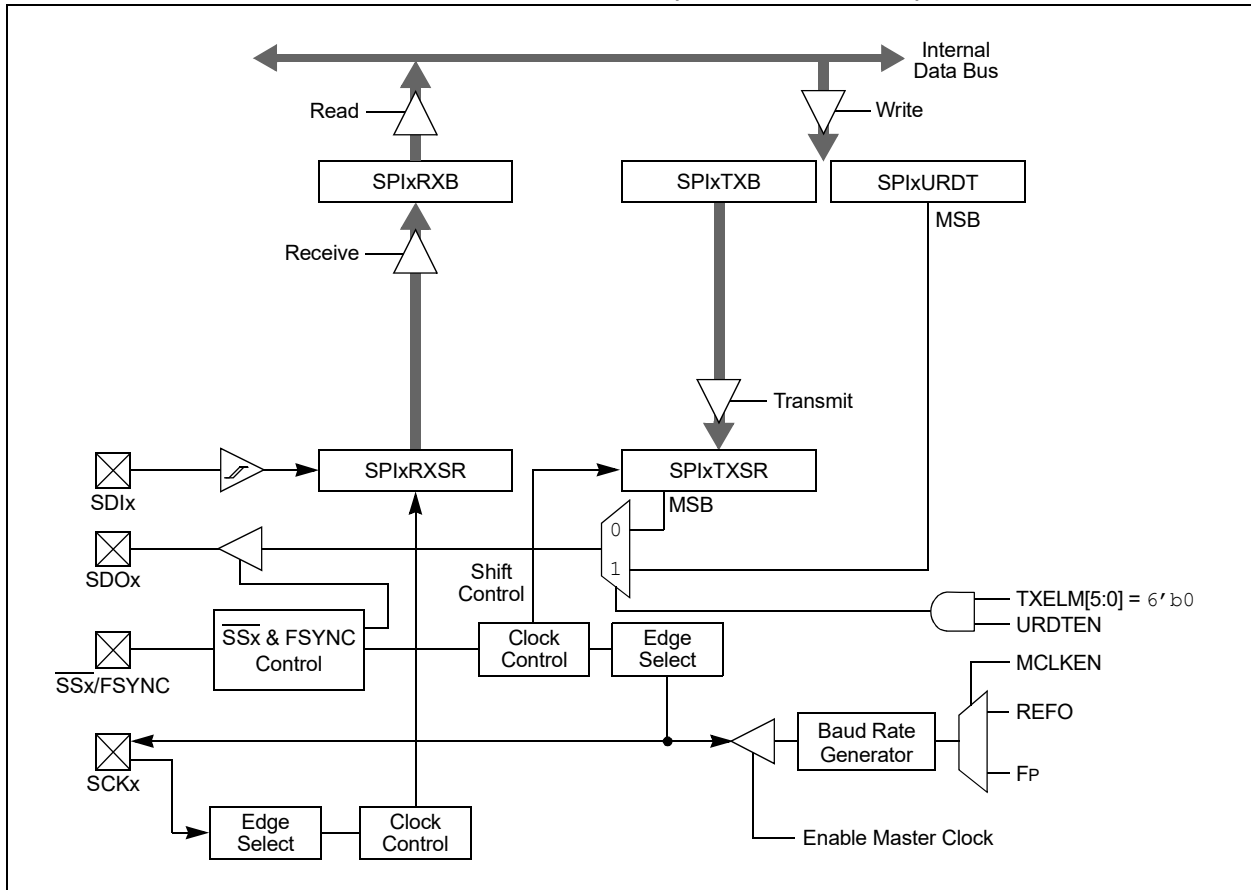
1. If using interrupts:
  - a) Clear the interrupt flag bits in the respective IFSx register.
  - b) Set the interrupt enable bits in the respective IECx register.
  - c) Write the SPIxIP bits in the respective IPCx register to set the interrupt priority.
2. Write the desired settings to the SPIxCON1L and SPIxCON1H registers with the MSTEN bit (SPIxCON1L[5]) = 1.
3. Clear the SPIROV bit (SPIxSTATL[6]).
4. Enable SPIx operation by setting the SPIEN bit (SPIxCON1L[15]).
5. Write the data to be transmitted to the SPIxBUFL and SPIxBUFH registers. Transmission (and reception) will start as soon as data are written to the SPIxBUFL and SPIxBUFH registers.

To set up the SPIx module for the Standard Client mode of operation:

1. Clear the SPIxBUF registers.
2. If using interrupts:
  - a) Clear the SPIxBUFL and SPIxBUFH registers.
  - b) Set the interrupt enable bits in the respective IECx register.
  - c) Write the SPIxIP bits in the respective IPCx register to set the interrupt priority.
3. Write the desired settings to the SPIxCON1L, SPIxCON1H and SPIxCON2L registers with the MSTEN bit (SPIxCON1L[5]) = 0.
4. Clear the SMP bit.
5. If the CKE bit (SPIxCON1L[8]) is set, then the SSEN bit (SPIxCON1L[7]) must be set to enable the SSx pin.
6. Clear the SPIROV bit (SPIxSTATL[6]).
7. Enable SPIx operation by setting the SPIEN bit (SPIxCON1L[15]).

# dsPIC33CK256MP508 FAMILY

FIGURE 17-1: SPIx MODULE BLOCK DIAGRAM (STANDARD MODE)



# dsPIC33CK256MP508 FAMILY

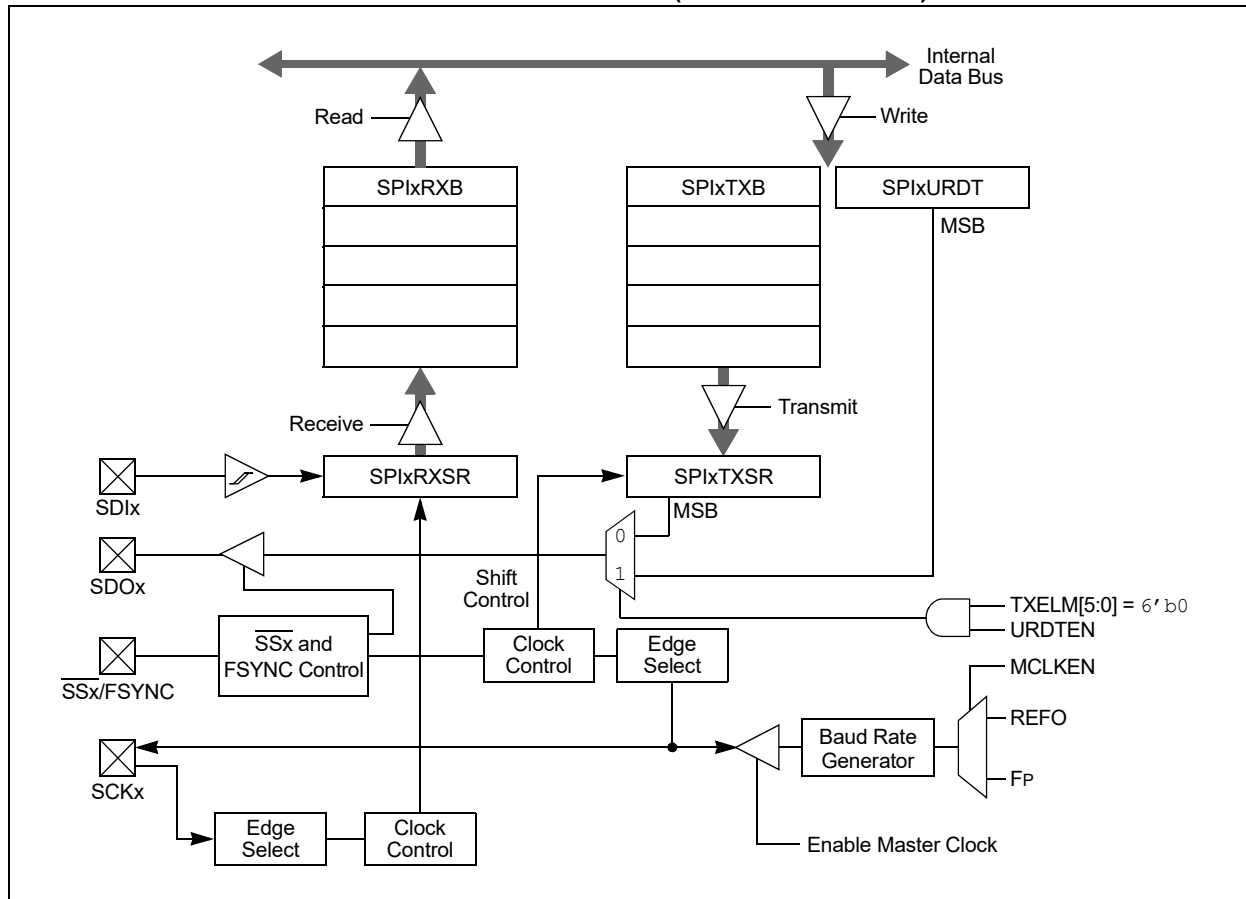
To set up the SPIx module for the Enhanced Buffer Host mode of operation:

- If using interrupts:
  - Clear the interrupt flag bits in the respective IFSx register.
  - Set the interrupt enable bits in the respective IECx register.
  - Write the SPIxIP bits in the respective IPCx register.
- Write the desired settings to the SPIxCON1L, SPIxCON1H and SPIxCON2L registers with MSTEN (SPIxCON1L[5]) = 1.
- Clear the SPIROV bit (SPIxSTATL[6]).
- Select Enhanced Buffer mode by setting the ENHBUF bit (SPIxCON1L[0]).
- Enable SPIx operation by setting the SPIEN bit (SPIxCON1L[15]).
- Write the data to be transmitted to the SPIxBUFL and SPIxBUFH registers. Transmission (and reception) will start as soon as data are written to the SPIxBUFL and SPIxBUFH registers.

To set up the SPIx module for the Enhanced Buffer Client mode of operation:

- Clear the SPIxBUFL and SPIxBUFH registers.
- If using interrupts:
  - Clear the interrupt flag bits in the respective IFSx register.
  - Set the interrupt enable bits in the respective IECx register.
  - Write the SPIxIP bits in the respective IPCx register to set the interrupt priority.
- Write the desired settings to the SPIxCON1L, SPIxCON1H and SPIxCON2L registers with the MSTEN bit (SPIxCON1L[5]) = 0.
- Clear the SMP bit.
- If the CKE bit is set, then the SSEN bit must be set, thus enabling the  $\overline{SSx}$  pin.
- Clear the SPIROV bit (SPIxSTATL[6]).
- Select Enhanced Buffer mode by setting the ENHBUF bit (SPIxCON1L[0]).
- Enable SPIx operation by setting the SPIEN bit (SPIxCON1L[15]).

**FIGURE 17-2: SPIx MODULE BLOCK DIAGRAM (ENHANCED MODE)**



# dsPIC33CK256MP508 FAMILY

---

To set up the SPIx module for Audio mode:

1. Clear the SPIxBUFL and SPIxBUFH registers.
2. If using interrupts:
  - a) Clear the interrupt flag bits in the respective IFSx register.
  - b) Set the interrupt enable bits in the respective IECx register.
  - a) Write the SPIxIP bits in the respective IPCx register to set the interrupt priority.
3. Write the desired settings to the SPIxCON1L, SPIxCON1H and SPIxCON2L registers with AUDEN (SPIxCON1H[15]) = 1.
4. Clear the SPIROV bit (SPIxSTATL[6]).
5. Enable SPIx operation by setting the SPIEN bit (SPIxCON1L[15]).
6. Write the data to be transmitted to the SPIxBUFL and SPIxBUFH registers. Transmission (and reception) will start as soon as data are written to the SPIxBUFL and SPIxBUFH registers.

# dsPIC33CK256MP508 FAMILY

## 17.1 SPI Control Registers

**REGISTER 17-1: SPIxCON1L: SPIx CONTROL REGISTER 1 LOW**

R/W-0	U-0	R/W-0	R/W-0	R/W-0	R/W-0	R/W-0	R/W-0
SPIEN	—	SPISIDL	DISSDO	MODE32 <sup>(1,4)</sup>	MODE16 <sup>(1,4)</sup>	SMP	CKE <sup>(1)</sup>
bit 15							bit 8

R/W-0	R/W-0	R/W-0	R/W-0	R/W-0	R/W-0	R/W-0	R/W-0
SSEN <sup>(2)</sup>	CKP	MSTEN	DISSDI	DISSCK	MCLKEN <sup>(3)</sup>	SPIFE	ENHBUF
bit 7							bit 0

**Legend:**

R = Readable bit                      W = Writable bit                      U = Unimplemented bit, read as '0'  
 -n = Value at POR                      '1' = Bit is set                      '0' = Bit is cleared                      x = Bit is unknown

bit 15            **SPIEN:** SPIx On bit  
                   1 = Enables module  
                   0 = Turns off and resets module, disables clocks, disables interrupt event generation, allows SFR modifications

bit 14            **Unimplemented:** Read as '0'

bit 13            **SPISIDL:** SPIx Stop in Idle Mode bit  
                   1 = Halts in CPU Idle mode  
                   0 = Continues to operate in CPU Idle mode

bit 12            **DISSDO:** Disable SDOx Output Port bit  
                   1 = SDOx pin is not used by the module; pin is controlled by port function  
                   0 = SDOx pin is controlled by the module

bit 11-10        **MODE32 and MODE16:** Serial Word Length Select bits<sup>(1,4)</sup>

MODE32	MODE16	AUDEN	Communication
1	x	0	32-Bit
0	1		16-Bit
0	0		8-Bit
1	1	1	24-Bit Data, 32-Bit FIFO, 32-Bit Channel/64-Bit Frame
1	0		32-Bit Data, 32-Bit FIFO, 32-Bit Channel/64-Bit Frame
0	1		16-Bit Data, 16-Bit FIFO, 32-Bit Channel/64-Bit Frame
0	0		16-Bit FIFO, 16-Bit Channel/32-Bit Frame

bit 9            **SMP:** SPIx Data Input Sample Phase bit  
Host Mode:  
                   1 = Input data sampled at the end of data output time  
                   0 = Input data sampled at the middle of data output time  
Client Mode:  
                   Input data always sampled at the middle of data output time, regardless of the SMP setting.

bit 8            **CKE:** SPIx Clock Edge Select bit<sup>(1)</sup>  
                   1 = Transmit happens on transition from active clock state to Idle clock state  
                   0 = Transmit happens on transition from Idle clock state to active clock state

- Note 1:** When AUDEN (SPIxCON1H[15]) = 1, this module functions as if CKE = 0, regardless of its actual value.  
**Note 2:** When FRMEN = 1, SSEN is not used.  
**Note 3:** MCLKEN can only be written when the SPIEN bit = 0.  
**Note 4:** This channel is not meaningful for DSP/PCM mode as LRC follows FRMSYPW.

# dsPIC33CK256MP508 FAMILY

## REGISTER 17-1: SPIxCON1L: SPIx CONTROL REGISTER 1 LOW (CONTINUED)

bit 7	<b>SSEN:</b> Client Select Enable bit (Client mode) <sup>(2)</sup> 1 = $\overline{SSx}$ pin is used by the macro in Client mode; $\overline{SSx}$ pin is used as the Client select input 0 = $\overline{SSx}$ pin is not used by the macro ( $\overline{SSx}$ pin will be controlled by the port I/O)
bit 6	<b>CKP:</b> Clock Polarity Select bit 1 = Idle state for clock is a high level; active state is a low level 0 = Idle state for clock is a low level; active state is a high level
bit 5	<b>MSTEN:</b> Host Mode Enable bit 1 = Host mode 0 = Client mode
bit 4	<b>DISSDI:</b> Disable SDIx Input Port bit 1 = SDIx pin is not used by the module; pin is controlled by port function 0 = SDIx pin is controlled by the module
bit 3	<b>DISSCK:</b> Disable SCKx Output Port bit 1 = SCKx pin is not used by the module; pin is controlled by port function 0 = SCKx pin is controlled by the module
bit 2	<b>MCLKEN:</b> Master Clock Enable bit <sup>(3)</sup> 1 = REFO is used by the BRG 0 = FP is used by the BRG
bit 1	<b>SPIFE:</b> Frame Sync Pulse Edge Select bit 1 = Frame Sync pulse (Idle-to-active edge) coincides with the first bit clock 0 = Frame Sync pulse (Idle-to-active edge) precedes the first bit clock
bit 0	<b>ENHBUF:</b> Enhanced Buffer Enable bit 1 = Enhanced Buffer mode is enabled 0 = Enhanced Buffer mode is disabled

- Note 1:** When AUDEN (SPIxCON1H[15]) = 1, this module functions as if CKE = 0, regardless of its actual value.
- 2:** When FRMEN = 1, SSEN is not used.
- 3:** MCLKEN can only be written when the SPIEN bit = 0.
- 4:** This channel is not meaningful for DSP/PCM mode as LRC follows FRMSYPW.

# dsPIC33CK256MP508 FAMILY

## REGISTER 17-2: SPIxCON1H: SPIx CONTROL REGISTER 1 HIGH

R/W-0	R/W-0	R/W-0	R/W-0	R/W-0	R/W-0	R/W-0	R/W-0
AUDEN <sup>(1)</sup>	SPISGNEXT	IGNROV	IGNTUR	AUDMONO <sup>(2)</sup>	URDTEN <sup>(3)</sup>	AUDMOD1 <sup>(4)</sup>	AUDMOD0 <sup>(4)</sup>
bit 15						bit 8	

R/W-0	R/W-0	R/W-0	R/W-0	R/W-0	R/W-0	R/W-0	R/W-0
FRMEN	FRMSYNC	FRMPOL	MSEN	FRMSYPW	FRMCNT2	FRMCNT1	FRMCNT0
bit 7						bit 0	

### Legend:

R = Readable bit	W = Writable bit	U = Unimplemented bit, read as '0'
-n = Value at POR	'1' = Bit is set	'0' = Bit is cleared
		x = Bit is unknown

- bit 15     **AUDEN:** Audio Codec Support Enable bit<sup>(1)</sup>  
 1 = Audio protocol is enabled; MSTEN controls the direction of both SCKx and frame (a.k.a. LRC), and this module functions as if FRMEN = 1, FRMSYNC = MSTEN, FRMCNT[2:0] = 001 and SMP = 0, regardless of their actual values  
 0 = Audio protocol is disabled
- bit 14     **SPISGNEXT:** SPIx Sign-Extend RX FIFO Read Data Enable bit  
 1 = Data from RX FIFO are sign-extended  
 0 = Data from RX FIFO are not sign-extended
- bit 13     **IGNROV:** Ignore Receive Overflow bit  
 1 = A Receive Overflow (ROV) is NOT a critical error; during ROV, data in the FIFO are not overwritten by the receive data  
 0 = A ROV is a critical error that stops SPI operation
- bit 12     **IGNTUR:** Ignore Transmit Underrun bit  
 1 = A Transmit Underrun (TUR) is NOT a critical error and data indicated by URDTEN are transmitted until the SPIxTXB is not empty  
 0 = A TUR is a critical error that stops SPI operation
- bit 11     **AUDMONO:** Audio Data Format Transmit bit<sup>(2)</sup>  
 1 = Audio data are mono (i.e., each data word is transmitted on both left and right channels)  
 0 = Audio data are stereo
- bit 10     **URDTEN:** Transmit Underrun Data Enable bit<sup>(3)</sup>  
 1 = Transmits data out of SPIxURDT register during Transmit Underrun conditions  
 0 = Transmits the last received data during Transmit Underrun conditions
- bit 9-8    **AUDMOD[1:0]:** Audio Protocol Mode Selection bits<sup>(4)</sup>  
 11 = PCM/DSP mode  
 10 = Right Justified mode: This module functions as if SPIFE = 1, regardless of its actual value  
 01 = Left Justified mode: This module functions as if SPIFE = 1, regardless of its actual value  
 00 = I<sup>2</sup>S mode: This module functions as if SPIFE = 0, regardless of its actual value
- bit 7     **FRMEN:** Framed SPIx Support bit  
 1 = Framed SPIx support is enabled ( $\overline{SSx}$  pin is used as the FSYNC input/output)  
 0 = Framed SPIx support is disabled

- Note 1:** AUDEN can only be written when the SPIEN bit = 0.  
**Note 2:** AUDMONO can only be written when the SPIEN bit = 0 and is only valid for AUDEN = 1.  
**Note 3:** URDTEN is only valid when IGNTUR = 1.  
**Note 4:** AUDMOD[1:0] can only be written when the SPIEN bit = 0 and is only valid when AUDEN = 1. When NOT in PCM/DSP mode, this module functions as if FRMSYPW = 1, regardless of its actual value.



# dsPIC33CK256MP508 FAMILY

---

## REGISTER 17-2: SPIxCON1H: SPIx CONTROL REGISTER 1 HIGH (CONTINUED)

- bit 6      **FRMSYNC**: Frame Sync Pulse Direction Control bit  
1 = Frame Sync pulse input (Client)  
0 = Frame Sync pulse output (Host)
- bit 5      **FRMPOL**: Frame Sync/Client Select Polarity bit  
1 = Frame Sync pulse/Client select is active-high  
0 = Frame Sync pulse/Client select is active-low
- bit 4      **MSEN**: Host Mode Client Select Enable bit  
1 = SPIx Client select support is enabled with polarity determined by FRMPOL ( $\overline{SSx}$  pin is automatically driven during transmission in Host mode)  
0 = Client select SPIx support is disabled ( $\overline{SSx}$  pin will be controlled by port I/O)
- bit 3      **FRMSYPW**: Frame Sync Pulse-Width bit  
1 = Frame Sync pulse is one serial word length wide (as defined by MODE[32,16]/WLENGTH[4:0])  
0 = Frame Sync pulse is one clock (SCKx) wide
- bit 2-0    **FRMCNT[2:0]**: Frame Sync Pulse Counter bits  
Controls the number of serial words transmitted per Sync pulse.  
111 = Reserved  
110 = Reserved  
101 = Generates a Frame Sync pulse on every 32 serial words  
100 = Generates a Frame Sync pulse on every 16 serial words  
011 = Generates a Frame Sync pulse on every 8 serial words  
010 = Generates a Frame Sync pulse on every 4 serial words  
001 = Generates a Frame Sync pulse on every 2 serial words (value used by audio protocols)  
000 = Generates a Frame Sync pulse on each serial word

- Note 1:** AUDEN can only be written when the SPIEN bit = 0.  
**2:** AUDMONO can only be written when the SPIEN bit = 0 and is only valid for AUDEN = 1.  
**3:** URDTEN is only valid when IGNTUR = 1.  
**4:** AUDMOD[1:0] can only be written when the SPIEN bit = 0 and is only valid when AUDEN = 1. When NOT in PCM/DSP mode, this module functions as if FRMSYPW = 1, regardless of its actual value.

# dsPIC33CK256MP508 FAMILY

## REGISTER 17-3: SPIxCON2L: SPIx CONTROL REGISTER 2 LOW

U-0	U-0	U-0	U-0	U-0	U-0	U-0	U-0
—	—	—	—	—	—	—	—
bit 15							bit 8

U-0	U-0	U-0	R/W-0	R/W-0	R/W-0	R/W-0	R/W-0
—	—	—	WLENGTH[4:0] <sup>(1,2)</sup>				—
bit 7							bit 0

### Legend:

R = Readable bit	W = Writable bit	U = Unimplemented bit, read as '0'
-n = Value at POR	'1' = Bit is set	'0' = Bit is cleared
		x = Bit is unknown

bit 15-5      **Unimplemented:** Read as '0'

bit 4-0      **WLENGTH[4:0]:** Variable Word Length bits<sup>(1,2)</sup>

11111 = 32-bit data  
 11110 = 31-bit data  
 11101 = 30-bit data  
 11100 = 29-bit data  
 11011 = 28-bit data  
 11010 = 27-bit data  
 11001 = 26-bit data  
 11000 = 25-bit data  
 10111 = 24-bit data  
 10110 = 23-bit data  
 10101 = 22-bit data  
 10100 = 21-bit data  
 10011 = 20-bit data  
 10010 = 19-bit data  
 10001 = 18-bit data  
 10000 = 17-bit data  
 01111 = 16-bit data  
 01110 = 15-bit data  
 01101 = 14-bit data  
 01100 = 13-bit data  
 01011 = 12-bit data  
 01010 = 11-bit data  
 01001 = 10-bit data  
 01000 = 9-bit data  
 00111 = 8-bit data  
 00110 = 7-bit data  
 00101 = 6-bit data  
 00100 = 5-bit data  
 00011 = 4-bit data  
 00010 = 3-bit data  
 00001 = 2-bit data  
 00000 = See MODE[32,16] bits in SPIxCON1L[11:10]

**Note 1:** These bits are effective when AUDEN = 0 only.

**Note 2:** Varying the length by changing these bits does not affect the depth of the TX/RX FIFO.

# dsPIC33CK256MP508 FAMILY

## REGISTER 17-4: SPIxSTATL: SPIx STATUS REGISTER LOW

U-0	U-0	U-0	HS/R/C-0	HSC/R-0	U-0	U-0	HSC/R-0
—	—	—	FRMERR	SPIBUSY	—	—	SPITUR <sup>(1)</sup>
bit 15							bit 8

HSC/R-0	HS/R/C-0	HSC/R-1	U-0	HSC/R-1	U-0	HSC/R-0	HSC/R-0
SRMT	SPIROV	SPIRBE	—	SPITBE	—	SPITBF	SPIRBF
bit 7							bit 0

<b>Legend:</b>	C = Clearable bit	U = Unimplemented, read as '0'
R = Readable bit	W = Writable bit	HSC = Hardware Settable/Clearable bit
-n = Value at POR	'1' = Bit is set	'0' = Bit is cleared
		HS = Hardware Settable bit

bit 15-13 **Unimplemented:** Read as '0'

bit 12 **FRMERR:** SPIx Frame Error Status bit

1 = Frame error is detected  
0 = No frame error is detected

bit 11 **SPIBUSY:** SPIx Activity Status bit

1 = Module is currently busy with some transactions  
0 = No ongoing transactions (at time of read)

bit 10-9 **Unimplemented:** Read as '0'

bit 8 **SPITUR:** SPIx Transmit Underrun Status bit<sup>(1)</sup>

1 = Transmit buffer has encountered a Transmit Underrun condition  
0 = Transmit buffer does not have a Transmit Underrun condition

bit 7 **SRMT:** Shift Register Empty Status bit

1 = No current or pending transactions (i.e., neither SPIxTXB or SPIxTXSR contains data to transmit)  
0 = Current or pending transactions

bit 6 **SPIROV:** SPIx Receive Overflow Status bit

1 = A new byte/half-word/word has been completely received when the SPIxRXB was full  
0 = No overflow

bit 5 **SPIRBE:** SPIx RX Buffer Empty Status bit

1 = RX buffer is empty  
0 = RX buffer is not empty

Standard Buffer Mode:

Automatically set in hardware when SPIxBUF is read from, reading SPIxRXB. Automatically cleared in hardware when SPIx transfers data from SPIxRXSR to SPIxRXB.

Enhanced Buffer Mode:

Indicates RXELM[5:0] = 000000.

bit 4 **Unimplemented:** Read as '0'

**Note 1:** SPITUR is cleared when SPIEN = 0. When IGNTUR = 1, SPITUR provides dynamic status of the Transmit Underrun condition, but does not stop RX/TX operation and does not need to be cleared by software.

# dsPIC33CK256MP508 FAMILY

---

## REGISTER 17-4: SPIxSTATL: SPIx STATUS REGISTER LOW (CONTINUED)

- bit 3      **SPITBE:** SPIx Transmit Buffer Empty Status bit  
1 = SPIxTXB is empty  
0 = SPIxTXB is not empty  
Standard Buffer Mode:  
Automatically set in hardware when SPIx transfers data from SPIxTXB to SPIxTXSR. Automatically cleared in hardware when SPIxBUF is written, loading SPIxTXB.  
Enhanced Buffer Mode:  
Indicates TXELM[5:0] = 000000.
- bit 2      **Unimplemented:** Read as '0'
- bit 1      **SPITBF:** SPIx Transmit Buffer Full Status bit  
1 = SPIxTXB is full  
0 = SPIxTXB not full  
Standard Buffer Mode:  
Automatically set in hardware when SPIxBUF is written, loading SPIxTXB. Automatically cleared in hardware when SPIx transfers data from SPIxTXB to SPIxTXSR.  
Enhanced Buffer Mode:  
Indicates TXELM[5:0] = 111111.
- bit 0      **SPIRBF:** SPIx Receive Buffer Full Status bit  
1 = SPIxRXB is full  
0 = SPIxRXB is not full  
Standard Buffer Mode:  
Automatically set in hardware when SPIx transfers data from SPIxRXSR to SPIxRXB. Automatically cleared in hardware when SPIxBUF is read from, reading SPIxRXB.  
Enhanced Buffer Mode:  
Indicates RXELM[5:0] = 111111.

**Note 1:** SPITUR is cleared when SPIEN = 0. When IGNTUR = 1, SPITUR provides dynamic status of the Transmit Underrun condition, but does not stop RX/TX operation and does not need to be cleared by software.

# dsPIC33CK256MP508 FAMILY

## REGISTER 17-5: SPIxSTATH: SPIx STATUS REGISTER HIGH

U-0	U-0	HSC/R-0	HSC/R-0	HSC/R-0	HSC/R-0	HSC/R-0	HSC/R-0
—	—	RXELM5 <sup>(3)</sup>	RXELM4 <sup>(2)</sup>	RXELM3 <sup>(1)</sup>	RXELM2	RXELM1	RXELM0
bit 15							bit 8

U-0	U-0	HSC/R-0	HSC/R-0	HSC/R-0	HSC/R-0	HSC/R-0	HSC/R-0
—	—	TXELM5 <sup>(3)</sup>	TXELM4 <sup>(2)</sup>	TXELM3 <sup>(1)</sup>	TXELM2	TXELM1	TXELM0
bit 7							bit 0

<b>Legend:</b>	HSC = Hardware Settable/Clearable bit		
R = Readable bit	W = Writable bit	U = Unimplemented bit, read as '0'	
-n = Value at POR	'1' = Bit is set	'0' = Bit is cleared	x = Bit is unknown

bit 15-14 **Unimplemented:** Read as '0'

bit 13-8 **RXELM[5:0]:** Receive Buffer Element Count bits (valid in Enhanced Buffer mode)<sup>(1,2,3)</sup>

bit 7-6 **Unimplemented:** Read as '0'

bit 5-0 **TXELM[5:0]:** Transmit Buffer Element Count bits (valid in Enhanced Buffer mode)<sup>(1,2,3)</sup>

- Note 1:** RXELM3 and TXELM3 bits are only present when FIFODEPTH = 8 or higher.  
**Note 2:** RXELM4 and TXELM4 bits are only present when FIFODEPTH = 16 or higher.  
**Note 3:** RXELM5 and TXELM5 bits are only present when FIFODEPTH = 32.

# dsPIC33CK256MP508 FAMILY

## REGISTER 17-6: SPIxIMSKL: SPIx INTERRUPT MASK REGISTER LOW

U-0	U-0	U-0	R/W-0	R/W-0	U-0	U-0	R/W-0	
—	—	—	FRMERREN	BUSYEN	—	—	SPITUREN	
bit 15								bit 8

R/W-0	R/W-0	R/W-0	U-0	R/W-0	U-0	R/W-0	R/W-0
SRMTEN	SPIROVEN	SPIRBEN	—	SPITBEN	—	SPITBFEN	SPIRBFEN
bit 7							bit 0

### Legend:

R = Readable bit

W = Writable bit

U = Unimplemented bit, read as '0'

-n = Value at POR

'1' = Bit is set

'0' = Bit is cleared

x = Bit is unknown

- bit 15-13 **Unimplemented:** Read as '0'
- bit 12 **FRMERREN:** Enable Interrupt Events via FRMERR bit  
 1 = Frame error generates an interrupt event  
 0 = Frame error does not generate an interrupt event
- bit 11 **BUSYEN:** Enable Interrupt Events via SPIBUSY bit  
 1 = SPIBUSY generates an interrupt event  
 0 = SPIBUSY does not generate an interrupt event
- bit 10-9 **Unimplemented:** Read as '0'
- bit 8 **SPITUREN:** Enable Interrupt Events via SPITUR bit  
 1 = Transmit Underrun (TUR) generates an interrupt event  
 0 = Transmit Underrun does not generate an interrupt event
- bit 7 **SRMTEN:** Enable Interrupt Events via SRMT bit  
 1 = Shift Register Empty (SRMT) generates interrupt events  
 0 = Shift Register Empty does not generate interrupt events
- bit 6 **SPIROVEN:** Enable Interrupt Events via SPIROV bit  
 1 = SPIx Receive Overflow (ROV) generates an interrupt event  
 0 = SPIx Receive Overflow does not generate an interrupt event
- bit 5 **SPIRBEN:** Enable Interrupt Events via SPIRBE bit  
 1 = SPIx RX buffer empty generates an interrupt event  
 0 = SPIx RX buffer empty does not generate an interrupt event
- bit 4 **Unimplemented:** Read as '0'
- bit 3 **SPITBEN:** Enable Interrupt Events via SPITBE bit  
 1 = SPIx transmit buffer empty generates an interrupt event  
 0 = SPIx transmit buffer empty does not generate an interrupt event
- bit 2 **Unimplemented:** Read as '0'
- bit 1 **SPITBFEN:** Enable Interrupt Events via SPITBF bit  
 1 = SPIx transmit buffer full generates an interrupt event  
 0 = SPIx transmit buffer full does not generate an interrupt event
- bit 0 **SPIRBFEN:** Enable Interrupt Events via SPIRBF bit  
 1 = SPIx receive buffer full generates an interrupt event  
 0 = SPIx receive buffer full does not generate an interrupt event

# dsPIC33CK256MP508 FAMILY

## REGISTER 17-7: SPIxIMSKH: SPIx INTERRUPT MASK REGISTER HIGH

R/W-0	U-0	R/W-0	R/W-0	R/W-0	R/W-0	R/W-0	R/W-0
RXWIEN	—	RXMSK5 <sup>(1)</sup>	RXMSK4 <sup>(1,4)</sup>	RXMSK3 <sup>(1,3)</sup>	RXMSK2 <sup>(1,2)</sup>	RXMSK1 <sup>(1)</sup>	RXMSK0 <sup>(1)</sup>
bit 15							bit 8

R/W-0	U-0	R/W-0	R/W-0	R/W-0	R/W-0	R/W-0	R/W-0
TXWIEN	—	TXMSK5 <sup>(1)</sup>	TXMSK4 <sup>(1,4)</sup>	TXMSK3 <sup>(1,3)</sup>	TXMSK2 <sup>(1,2)</sup>	TXMSK1 <sup>(1)</sup>	TXMSK0 <sup>(1)</sup>
bit 7							bit 0

### Legend:

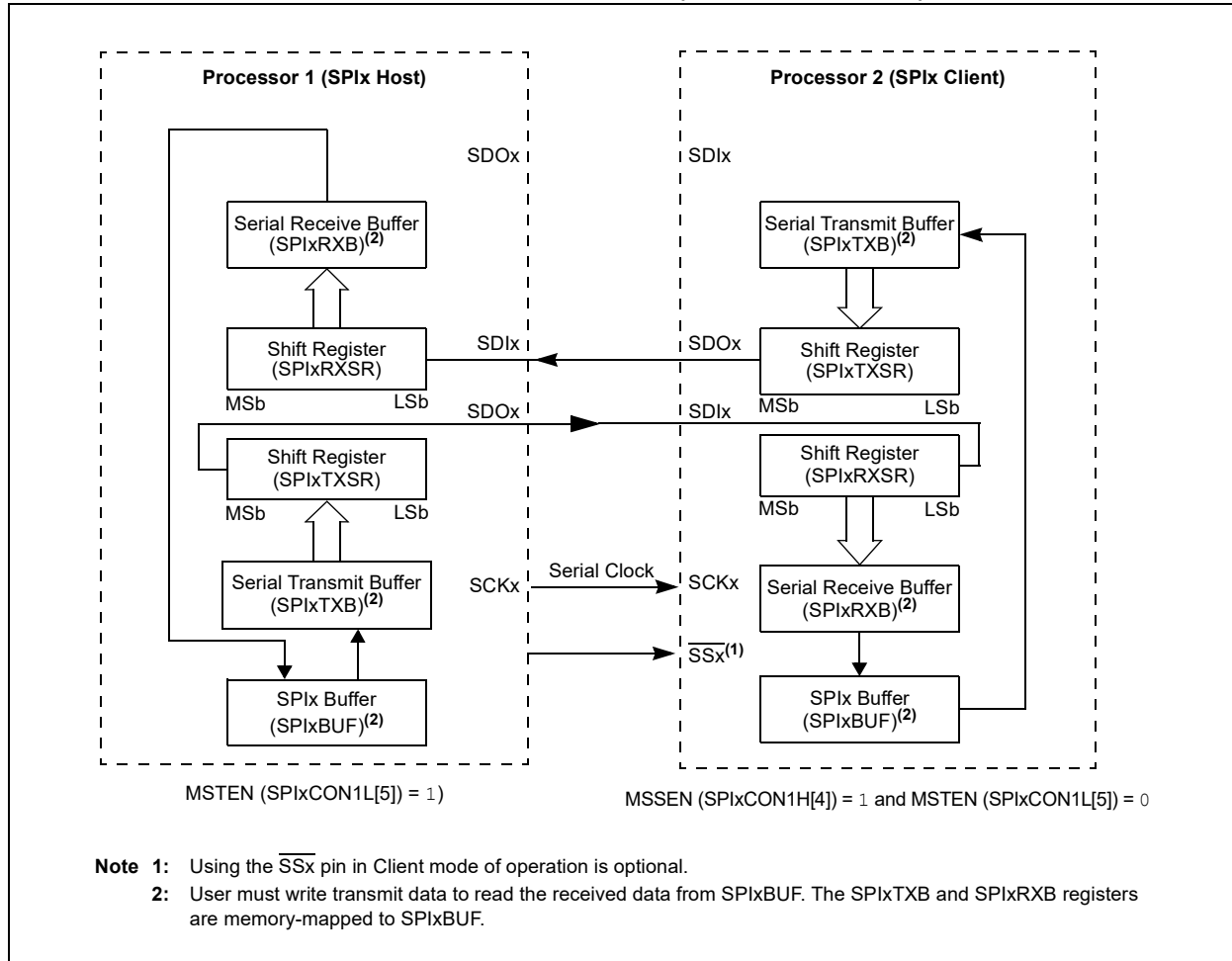
R = Readable bit	W = Writable bit	U = Unimplemented bit, read as '0'
-n = Value at POR	'1' = Bit is set	'0' = Bit is cleared
		x = Bit is unknown

- bit 15      **RXWIEN:** Receive Watermark Interrupt Enable bit  
             1 = Triggers receive buffer element watermark interrupt when RXMSK[5:0] ≤ RXELM[5:0]  
             0 = Disables receive buffer element watermark interrupt
- bit 14      **Unimplemented:** Read as '0'
- bit 13-8    **RXMSK[5:0]:** RX Buffer Mask bits<sup>(1,2,3,4)</sup>  
             RX mask bits; used in conjunction with the RXWIEN bit.
- bit 7        **TXWIEN:** Transmit Watermark Interrupt Enable bit  
             1 = Triggers transmit buffer element watermark interrupt when TXMSK[5:0] = TXELM[5:0]  
             0 = Disables transmit buffer element watermark interrupt
- bit 6        **Unimplemented:** Read as '0'
- bit 5-0     **TXMSK[5:0]:** TX Buffer Mask bits<sup>(1,2,3,4)</sup>  
             TX mask bits; used in conjunction with the TXWIEN bit.

- Note 1:** Mask values higher than FIFODEPTH are not valid. The module will not trigger a match for any value in this case.
- 2:** RXMSK2 and TXMSK2 bits are only present when FIFODEPTH = 8 or higher.
- 3:** RXMSK3 and TXMSK3 bits are only present when FIFODEPTH = 16 or higher.
- 4:** RXMSK4 and TXMSK4 bits are only present when FIFODEPTH = 32.

# dsPIC33CK256MP508 FAMILY

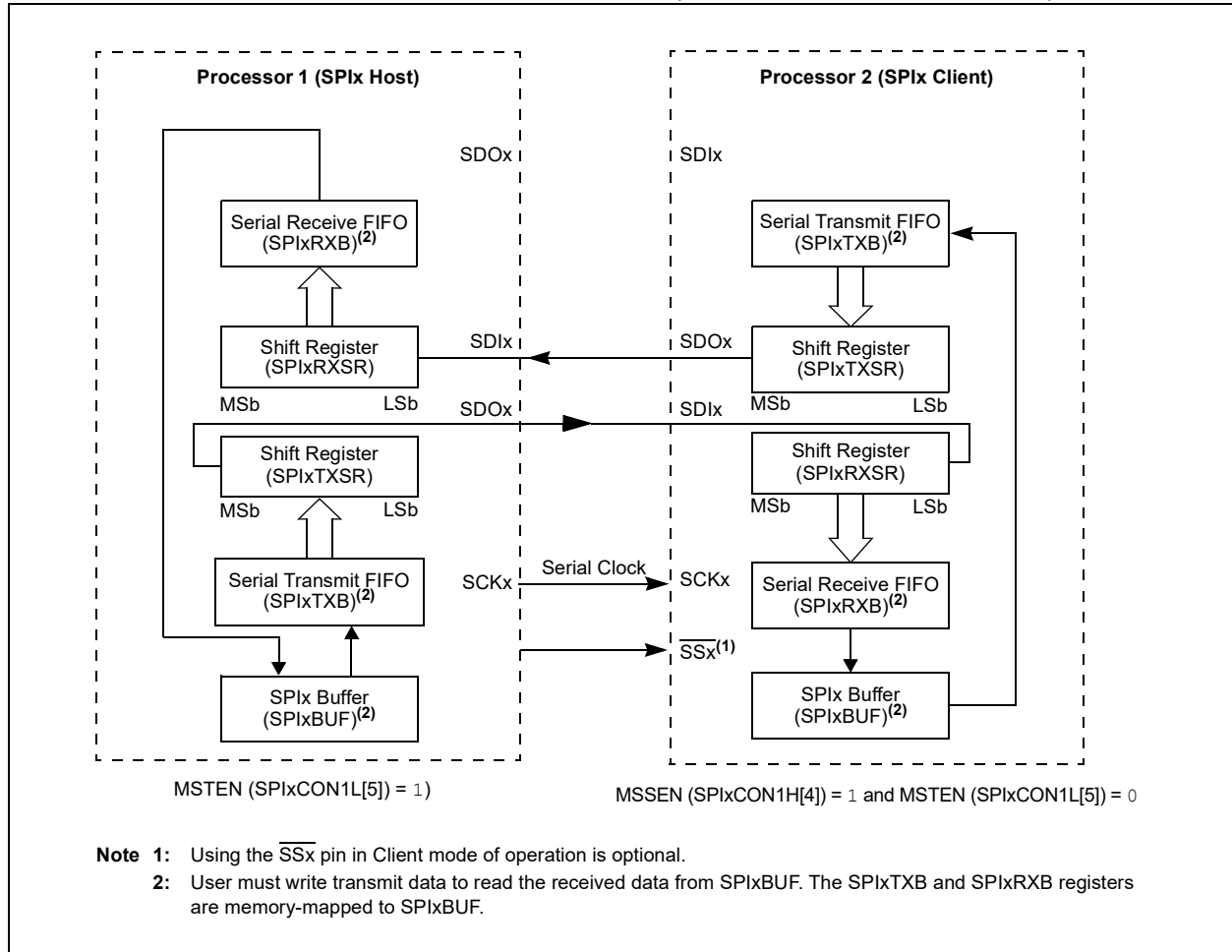
**FIGURE 17-3: SPIx HOST/CLIENT CONNECTION (STANDARD MODE)**



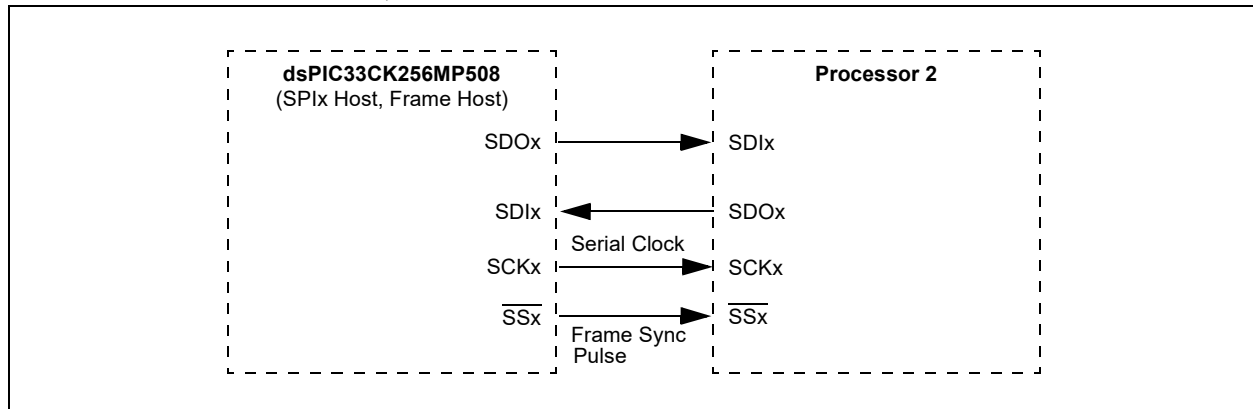


# dsPIC33CK256MP508 FAMILY

**FIGURE 17-4: SPIx HOST/CLIENT CONNECTION (ENHANCED BUFFER MODES)**

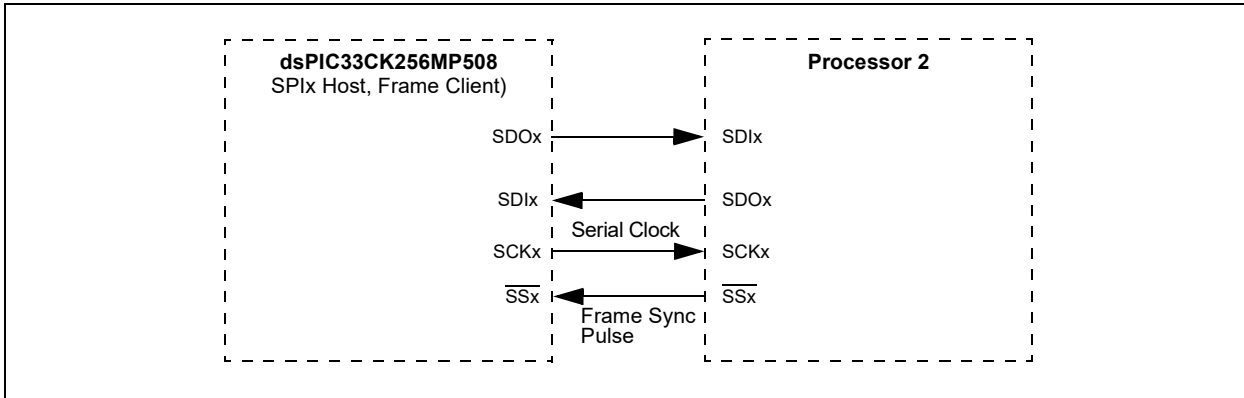


**FIGURE 17-5: SPIx HOST, FRAME HOST CONNECTION DIAGRAM**

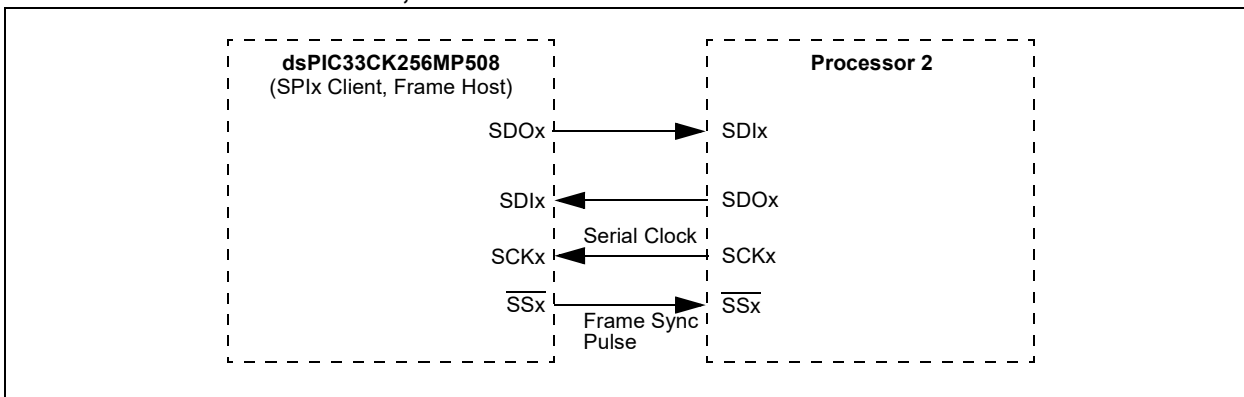


# dsPIC33CK256MP508 FAMILY

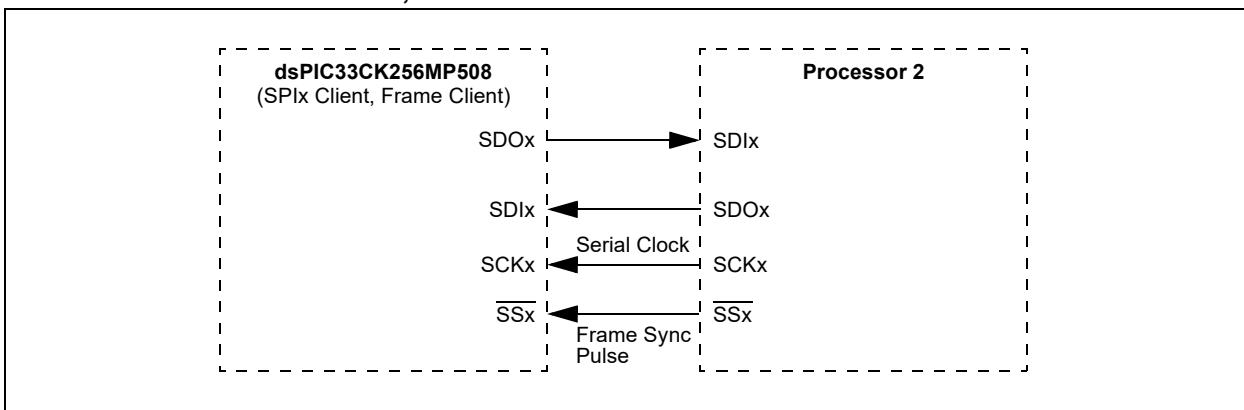
**FIGURE 17-6: SPIx HOST, FRAME CLIENT CONNECTION DIAGRAM**



**FIGURE 17-7: SPIx CLIENT, FRAME HOST CONNECTION DIAGRAM**



**FIGURE 17-8: SPIx CLIENT, FRAME CLIENT CONNECTION DIAGRAM**



**EQUATION 17-1: RELATIONSHIP BETWEEN DEVICE AND SPIx CLOCK SPEED**

$$Baud\ Rate = \frac{FPB}{(2 * (SPIxBRG + 1))}$$

Where:

FPB is the Peripheral Bus Clock Frequency.

## 18.0 INTER-INTEGRATED CIRCUIT (I<sup>2</sup>C)

**Note 1:** This data sheet summarizes the features of the dsPIC33CK256MP508 family of devices. It is not intended to be a comprehensive reference source. For more information, refer to “**Inter-Integrated Circuit (I<sup>2</sup>C)**” ([www.microchip.com/DS70000195](http://www.microchip.com/DS70000195)) in the “*dsPIC33/PIC24 Family Reference Manual*”.

The Inter-Integrated Circuit (I<sup>2</sup>C) module is a serial interface useful for communicating with other peripheral or microcontroller devices. These peripheral devices may be serial EEPROMs, display drivers, A/D Converters, etc.

The I<sup>2</sup>C module supports these features:

- Independent Host and Client Logic
- 7-Bit and 10-Bit Device Addresses
- General Call Address as Defined in the I<sup>2</sup>C Protocol
- Clock Stretching to Provide Delays for the Processor to Respond to a Client Data Request
- Both 100 kHz and 400 kHz Bus Specifications
- Configurable Address Masking
- Multi-Host modes to Prevent Loss of Messages in Arbitration
- Bus Repeater mode, Allowing the Acceptance of All Messages as a Client, regardless of the Address
- Automatic SCL
- SMBus Compatible Voltage Thresholds

A block diagram of the module is shown in [Figure 18-1](#).

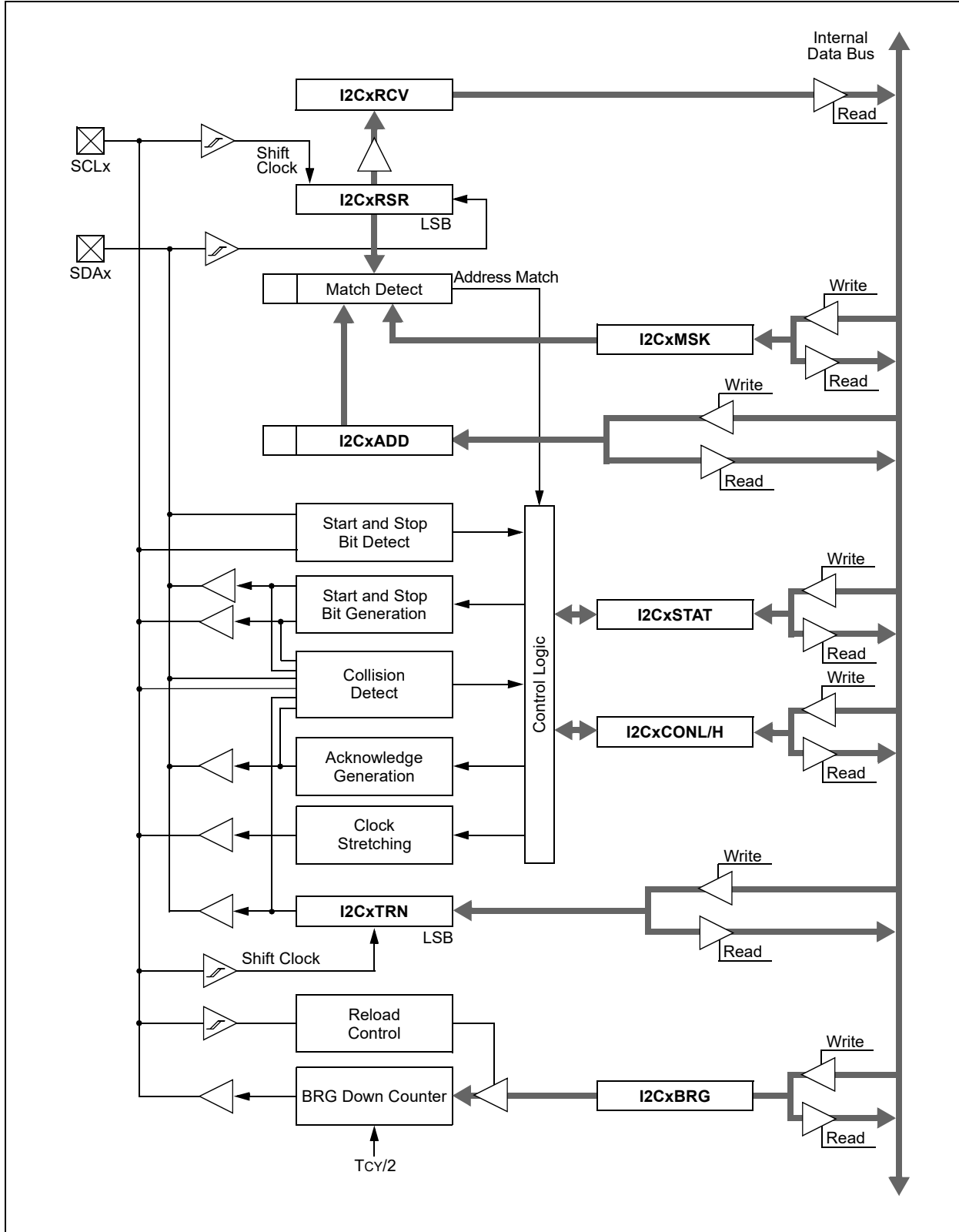
## 18.1 Communicating as a Host in a Single Host Environment

The details of sending a message in Host mode depends on the communication protocol for the device being communicated with. Typically, the sequence of events is as follows:

1. Assert a Start condition on SDAx and SCLx.
2. Send the I<sup>2</sup>C device address byte to the Client with a write indication.
3. Wait for and verify an Acknowledge from the Client.
4. Send the first data byte (sometimes known as the command) to the Client.
5. Wait for and verify an Acknowledge from the Client.
6. Send the serial memory address low byte to the Client.
7. Repeat Steps 4 and 5 until all data bytes are sent.
8. Assert a Repeated Start condition on SDAx and SCLx.
9. Send the device address byte to the Client with a read indication.
10. Wait for and verify an Acknowledge from the Client.
11. Enable Host reception to receive serial memory data.
12. Generate an ACK or NACK condition at the end of a received byte of data.
13. Generate a Stop condition on SDAx and SCLx.

# dsPIC33CK256MP508 FAMILY

FIGURE 18-1: I2Cx BLOCK DIAGRAM



## 18.2 Setting Baud Rate When Operating as a Bus Host

To compute the Baud Rate Generator reload value, use [Equation 18-1](#).

### EQUATION 18-1: COMPUTING BAUD RATE RELOAD VALUE<sup>(1,2,3)</sup>

$$I2CxBRG = ((1/(F_{SCL} - \text{Delay}) \cdot F_P/2) - 2$$

- Note 1:** These clock rate values are for guidance only. The actual clock rate should be measured in its intended application.
- 2:** Typical value of delay varies from 110 ns to 150 ns.
- 3:** I2CxBRG values of 0 to 3 are expressly forbidden. The user should never program the I2CxBRG with a value of 0x0, 0x1, 0x2 or 0x3 as indeterminate results may occur.

## 18.3 Client Address Masking

The I2CxMSK register ([Register 18-4](#)) designates address bit positions as “don’t care” for both 7-Bit and 10-Bit Addressing modes. Setting a particular bit location (= 1) in the I2CxMSK register causes the Client module to respond, whether the corresponding address bit value is a ‘0’ or a ‘1’. For example, when I2CxMSK is set to ‘0010000000’, the Client module will detect both addresses, ‘0000000000’ and ‘0010000000’.

To enable address masking, the Intelligent Peripheral Management Interface (IPMI) must be disabled by clearing the STRICT bit (I2CxCONL[11]).

**Note:** As a result of changes in the I<sup>2</sup>C protocol, the addresses in [Table 18-2](#) are reserved and will not be Acknowledged in Client mode. This includes any address mask settings that include any of these addresses.

**TABLE 18-1: I2Cx CLOCK RATES<sup>(1,2)</sup>**

Fcy	FSCL	I2CxBRG Value	
		Decimal	Hexadecimal
100 MHz	1 MHz	41	29
100 MHz	400 kHz	116	74
100 MHz	100 kHz	491	1EB
80 MHz	1 MHz	32	20
80 MHz	400 kHz	92	5C
80 MHz	100 kHz	392	188
60 MHz	1 MHz	24	18
60 MHz	400 kHz	69	45
60 MHz	100 kHz	294	126
40 MHz	1 MHz	15	0F
40 MHz	400 kHz	45	2D
40 MHz	100 kHz	195	C3
20 MHz	1 MHz	7	7
20 MHz	400 kHz	22	16
20 MHz	100 kHz	97	61

**Note 1:** Based on Fcy = FOSC/2; Doze mode and PLL are disabled.

**2:** These clock rate values are for guidance only. The actual clock rate can be affected by various system-level parameters. The actual clock rate should be measured in its intended application.

# dsPIC33CK256MP508 FAMILY

**TABLE 18-2: I2Cx RESERVED ADDRESSES<sup>(1)</sup>**

Client Address	R/W Bit	Description
0000 000	0	General Call Address <sup>(2)</sup>
0000 000	1	Start Byte
0000 001	x	Cbus Address
0000 01x	x	Reserved
0000 1xx	x	HS Mode Host Code
1111 0xx	x	10-Bit Client Upper Byte <sup>(3)</sup>
1111 1xx	x	Reserved

**Note 1:** The address bits listed here will never cause an address match independent of address mask settings.

**2:** This address will be Acknowledged only if GCEN = 1.

**3:** A match on this address can only occur on the upper byte in 10-Bit Addressing mode.

## 18.4 SMBus Support

The dsPIC33CK256MP508 family devices have support for SMBus through options in the input voltage thresholds. There are two control bits to select one of three options: SMEN (I2CxCONL[8]) and Configuration bit, SMBEN (FDEVOPT[10]). [Table 18-3](#) details the setting of these control bits.

**TABLE 18-3: I<sup>2</sup>C PIN VOLTAGE THRESHOLD**

	SMEN SFR Bit (I2CxCONL[8])	SMBEN Configuration Bit (FDEVOPT[10])
I <sup>2</sup> C (default)	0	x
SMBus 2.0	1	0
SMBus 3.0	1	1

# dsPIC33CK256MP508 FAMILY

## 18.5 I<sup>2</sup>C Control Registers

**REGISTER 18-1: I2CxCONL: I2Cx CONTROL REGISTER LOW**

R/W-0	U-0	HC/R/W-0	R/W-1	R/W-0	R/W-0	R/W-0	R/W-0
I2CEN	—	I2CSIDL	SCLREL <sup>(1)</sup>	STRICT	A10M	DISSLW	SMEN
bit 15							bit 8

R/W-0	R/W-0	R/W-0	HC/R/W-0	HC/R/W-0	HC/R/W-0	HC/R/W-0	HC/R/W-0
GCEN	STREN	ACKDT	ACKEN	RCEN	PEN	RSEN	SEN
bit 7							bit 0

<b>Legend:</b>	HC = Hardware Clearable bit
R = Readable bit	W = Writable bit
-n = Value at POR	'1' = Bit is set
	U = Unimplemented bit, read as '0'
	'0' = Bit is cleared
	x = Bit is unknown

- bit 15      **I2CEN:** I2Cx Enable bit (writable from software only)  
 1 = Enables the I2Cx module, and configures the SDAx and SCLx pins as serial port pins  
 0 = Disables the I2Cx module; all I<sup>2</sup>C pins are controlled by port functions
- bit 14      **Unimplemented:** Read as '0'
- bit 13      **I2CSIDL:** I2Cx Stop in Idle Mode bit  
 1 = Discontinues module operation when device enters Idle mode  
 0 = Continues module operation in Idle mode
- bit 12      **SCLREL:** SCLx Release Control bit (I<sup>2</sup>C Client mode only)<sup>(1)</sup>  
 1 = Releases the SCLx clock  
 0 = Holds the SCLx clock low (clock stretch)  
If STREN = 1:<sup>(2)</sup>  
 User software may write '0' to initiate a clock stretch and write '1' to release the clock. Hardware clears at the beginning of every Client data byte transmission. Hardware clears at the end of every Client address byte reception. Hardware clears at the end of every Client data byte reception.  
If STREN = 0:  
 User software may only write '1' to release the clock. Hardware clears at the beginning of every Client data byte transmission. Hardware clears at the end of every Client address byte reception.
- bit 11      **STRICT:** I2Cx Strict Reserved Address Rule Enable bit  
 1 = Strict reserved addressing is enforced; for reserved addresses, refer to [Table 18-2](#).  
 (In Client Mode) – The device doesn't respond to reserved address space and addresses falling in that category are NACKed.  
 (In Host Mode) – The device is allowed to generate addresses with reserved address space.  
 0 = Reserved addressing would be Acknowledged.  
 (In Client Mode) – The device will respond to an address falling in the reserved address space. When there is a match with any of the reserved addresses, the device will generate an ACK.  
 (In Host Mode) – Reserved.
- bit 10      **A10M:** 10-Bit Client Address Flag bit  
 1 = I2CxADD is a 10-bit Client address  
 0 = I2CxADD is a 7-bit Client address
- bit 9        **DISSLW:** Slew Rate Control Disable bit  
 1 = Slew rate control is disabled for Standard Speed mode (100 kHz, also disabled for 1 MHz mode)  
 0 = Slew rate control is enabled for High-Speed mode (400 kHz)

**Note 1:** Automatically cleared to '0' at the beginning of Client transmission; automatically cleared to '0' at the end of Client reception.

**2:** Automatically cleared to '0' at the beginning of Client transmission.

# dsPIC33CK256MP508 FAMILY

---

## REGISTER 18-1: I2CxCONL: I2Cx CONTROL REGISTER LOW (CONTINUED)

- bit 8      **SMEN:** SMBus Input Levels Enable bit  
1 = Enables input logic so thresholds are compliant with the SMBus specification  
0 = Disables SMBus-specific inputs
- bit 7      **GCEN:** General Call Enable bit (I<sup>2</sup>C Client mode only)  
1 = Enables interrupt when a general call address is received in I2CxRSR; module is enabled for reception  
0 = General call address is disabled.
- bit 6      **STREN:** SCLx Clock Stretch Enable bit  
In I<sup>2</sup>C Client mode only; used in conjunction with the SCLREL bit.  
1 = Enables clock stretching  
0 = Disables clock stretching
- bit 5      **ACKDT:** Acknowledge Data bit  
In I<sup>2</sup>C Host mode during Host Receive mode. The value that will be transmitted when the user initiates an Acknowledge sequence at the end of a receive.  
In I<sup>2</sup>C Client mode when AHEN = 1 or DHEN = 1. The value that the Client will transmit when it initiates an Acknowledge sequence at the end of an address or data reception.  
1 = NACK is sent  
0 = ACK is sent
- bit 4      **ACKEN:** Acknowledge Sequence Enable bit  
In I<sup>2</sup>C Host mode only; applicable during Host Receive mode.  
1 = Initiates Acknowledge sequence on SDAx and SCLx pins, and transmits ACKDT data bit  
0 = Acknowledge sequence is Idle
- bit 3      **RCEN:** Receive Enable bit (I<sup>2</sup>C Host mode only)  
1 = Enables Receive mode for I<sup>2</sup>C; automatically cleared by hardware at end of 8-bit receive data byte  
0 = Receive sequence is not in progress
- bit 2      **PEN:** Stop Condition Enable bit (I<sup>2</sup>C Host mode only)  
1 = Initiates Stop condition on SDAx and SCLx pins  
0 = Stop condition is Idle
- bit 1      **RSEN:** Restart Condition Enable bit (I<sup>2</sup>C Host mode only)  
1 = Initiates Restart condition on SDAx and SCLx pins  
0 = Restart condition is Idle
- bit 0      **SEN:** Start Condition Enable bit (I<sup>2</sup>C Host mode only)  
1 = Initiates Start condition on SDAx and SCLx pins  
0 = Start condition is Idle

**Note 1:** Automatically cleared to '0' at the beginning of Client transmission; automatically cleared to '0' at the end of Client reception.

**2:** Automatically cleared to '0' at the beginning of Client transmission.



# dsPIC33CK256MP508 FAMILY

## REGISTER 18-2: I2CxCONH: I2Cx CONTROL REGISTER HIGH

U-0	U-0	U-0	U-0	U-0	U-0	U-0	U-0
—	—	—	—	—	—	—	—
bit 15							bit 8

U-0	R/W-0	R/W-0	R/W-0	R/W-0	R/W-0	R/W-0	R/W-0
—	PCIE	SCIE	BOEN	SDAHT	SBCDE	AHEN	DHEN
bit 7							bit 0

### Legend:

R = Readable bit                      W = Writable bit                      U = Unimplemented bit, read as '0'  
 -n = Value at POR                      '1' = Bit is set                      '0' = Bit is cleared                      x = Bit is unknown

- bit 15-7      **Unimplemented:** Read as '0'
- bit 6      **PCIE:** Stop Condition Interrupt Enable bit (I<sup>2</sup>C Client mode only).  
 1 = Enables interrupt on detection of Stop condition  
 0 = Stop detection interrupts are disabled
- bit 5      **SCIE:** Start Condition Interrupt Enable bit (I<sup>2</sup>C Client mode only)  
 1 = Enables interrupt on detection of Start or Restart conditions  
 0 = Start detection interrupts are disabled
- bit 4      **BOEN:** Buffer Overwrite Enable bit (I<sup>2</sup>C Client mode only)  
 1 = I2CxRCV is updated and an ACK is generated for a received address/data byte, ignoring the state of the I2COV bit only if RBF bit = 0  
 0 = I2CxRCV is only updated when I2COV is clear
- bit 3      **SDAHT:** SDAx Hold Time Selection bit  
 1 = Minimum of 300 ns hold time on SDAx after the falling edge of SCLx  
 0 = Minimum of 100 ns hold time on SDAx after the falling edge of SCLx
- bit 2      **SBCDE:** Client Mode Bus Collision Detect Enable bit (I<sup>2</sup>C Client mode only)  
 If, on the rising edge of SCLx, SDAx is sampled low when the module is outputting a high state, the BCL bit is set and the bus goes Idle. This Detection mode is only valid during data and ACK transmit sequences.  
 1 = Enables Client bus collision interrupts  
 0 = Client bus collision interrupts are disabled
- bit 1      **AHEN:** Address Hold Enable bit (I<sup>2</sup>C Client mode only)  
 1 = Following the 8th falling edge of SCLx for a matching received address byte; SCLREL bit (I2CxCONL[12]) will be cleared and the SCLx will be held low  
 0 = Address holding is disabled
- bit 0      **DHEN:** Data Hold Enable bit (I<sup>2</sup>C Client mode only)  
 1 = Following the 8th falling edge of SCLx for a received data byte; Client hardware clears the SCLREL bit (I2CxCONL[12]) and SCLx is held low  
 0 = Data holding is disabled

# dsPIC33CK256MP508 FAMILY

## REGISTER 18-3: I2CxSTAT: I2Cx STATUS REGISTER

HSC/R-0	HSC/R-0	HSC/R-0	U-0	U-0	HSC/R/C-0	HSC/R-0	HSC/R-0
ACKSTAT	TRSTAT	ACKTIM	—	—	BCL	GCSTAT	ADD10
bit 15						bit 8	

HS/R/C-0	HS/R/C-0	HSC/R-0	HSC/R-0	HSC/R-0	HSC/R-0	HSC/R-0	HSC/R-0
IWCOL	I2COV	D/ $\bar{A}$	P	S	R/ $\bar{W}$	RBF	TBF
bit 7						bit 0	

<b>Legend:</b>	C = Clearable bit	HSC = Hardware Settable/Clearable bit
R = Readable bit	W = Writable bit	U = Unimplemented bit, read as '0'
-n = Value at POR	'1' = Bit is set	'0' = Bit is cleared
		HS = Hardware Settable bit

- bit 15      **ACKSTAT:** Acknowledge Status bit (updated in all Host and Client modes)  
 1 = Acknowledge was not received from Client  
 0 = Acknowledge was received from Client
- bit 14      **TRSTAT:** Transmit Status bit (when operating as I<sup>2</sup>C Host; applicable to Host transmit operation)  
 1 = Host transmit is in progress (8 bits + ACK)  
 0 = Host transmit is not in progress
- bit 13      **ACKTIM:** Acknowledge Time Status bit (valid in I<sup>2</sup>C Client mode only)  
 1 = Indicates I<sup>2</sup>C bus is in an Acknowledge sequence, set on 8th falling edge of SCLx clock  
 0 = Not an Acknowledge sequence, cleared on 9th rising edge of SCLx clock
- bit 12-11   **Unimplemented:** Read as '0'
- bit 10      **BCL:** Bus Collision Detect bit (Host/Client mode; cleared when I<sup>2</sup>C module is disabled, I2CEN = 0)  
 1 = A bus collision has been detected during a Host or Client transmit operation  
 0 = No bus collision has been detected
- bit 9        **GCSTAT:** General Call Status bit (cleared after Stop detection)  
 1 = General call address was received  
 0 = General call address was not received
- bit 8        **ADD10:** 10-Bit Address Status bit (cleared after Stop detection)  
 1 = 10-bit address was matched  
 0 = 10-bit address was not matched
- bit 7        **IWCOL:** I2Cx Write Collision Detect bit  
 1 = An attempt to write to the I2CxTRN register failed because the I<sup>2</sup>C module is busy; must be cleared in software  
 0 = No collision
- bit 6        **I2COV:** I2Cx Receive Overflow Flag bit  
 1 = A byte was received while the I2CxRCV register is still holding the previous byte; I2COV is a “don't care” in Transmit mode, must be cleared in software  
 0 = No overflow
- bit 5        **D/ $\bar{A}$ :** Data/Address bit (when operating as I<sup>2</sup>C Client)  
 1 = Indicates that the last byte received was data  
 0 = Indicates that the last byte received or transmitted was an address
- bit 4        **P:** I2Cx Stop bit  
 Updated when Start, Reset or Stop is detected; cleared when the I<sup>2</sup>C module is disabled, I2CEN = 0.  
 1 = Indicates that a Stop bit has been detected last  
 0 = Stop bit was not detected last

# dsPIC33CK256MP508 FAMILY

## REGISTER 18-3: I2CxSTAT: I2Cx STATUS REGISTER (CONTINUED)

- bit 3      **S:** I2Cx Start bit  
 Updated when Start, Reset or Stop is detected; cleared when the I<sup>2</sup>C module is disabled, I2CEN = 0.  
 1 = Indicates that a Start (or Repeated Start) bit has been detected last  
 0 = Start bit was not detected last
- bit 2      **R/W:** Read/Write Information bit (when operating as I<sup>2</sup>C Client)  
 1 = Read: Indicates the data transfer is output from the Client  
 0 = Write: Indicates the data transfer is input to the Client
- bit 1      **RBF:** Receive Buffer Full Status bit  
 1 = Receive is complete, I2CxRCV is full  
 0 = Receive is not complete, I2CxRCV is empty
- bit 0      **TBF:** Transmit Buffer Full Status bit  
 1 = Transmit is in progress, I2CxTRN is full (8 bits of data)  
 0 = Transmit is complete, I2CxTRN is empty

## REGISTER 18-4: I2CxMSK: I2Cx CLIENT MODE ADDRESS MASK REGISTER

U-0	U-0	U-0	U-0	U-0	U-0	R/W-0	R/W-0
—	—	—	—	—	—	MSK[9:8]	
bit 15						bit 8	

R/W-0	R/W-0	R/W-0	R/W-0	R/W-0	R/W-0	R/W-0	R/W-0
MSK[7:0]							
bit 7						bit 0	

### Legend:

R = Readable bit	W = Writable bit	U = Unimplemented bit, read as '0'
-n = Value at POR	'1' = Bit is set	'0' = Bit is cleared      x = Bit is unknown

bit 15-10      **Unimplemented:** Read as '0'

bit 9-0      **MSK[9:0]:** I2Cx Mask for Address Bit x Select bits

- 1 = Enables masking for bit x of the incoming message address; bit match is not required in this position  
 0 = Disables masking for bit x; bit match is required in this position

# dsPIC33CK256MP508 FAMILY

---

NOTES:

# dsPIC33CK256MP508 FAMILY

## 19.0 PARALLEL MASTER PORT (PMP)

**Note 1:** This data sheet summarizes the features of the dsPIC33CK256MP508 family of devices. It is not intended to be a comprehensive reference source. To complement the information in this data sheet, refer to “**Parallel Master Port (PMP)**” ([www.microchip.com/DS70005344](http://www.microchip.com/DS70005344)) in the “dsPIC33/PIC24 Family Reference Manual”.

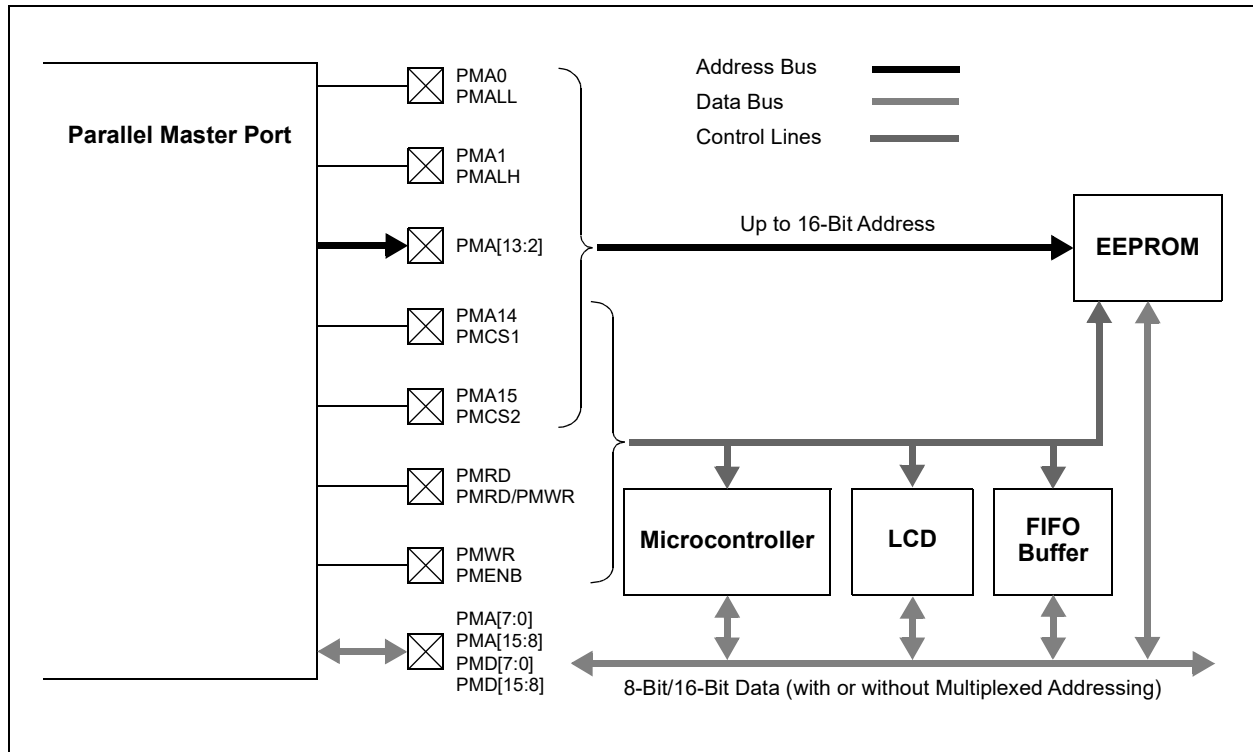
**2:** Not all device variants include the PMP. Refer to [Table 1](#) and [Table 2](#) for availability.

The Parallel Master Port (PMP) is a parallel 8-bit/16-bit I/O module specifically designed to communicate with a wide variety of parallel devices, such as communication peripherals, LCDs, external memory devices and microcontrollers. Because the interfaces to parallel

peripherals vary significantly, the PMP module is highly configurable. The key features of the PMP module include:

- Host and Client Operating modes
- Up to 16 Programmable Address Lines
- Up to Two Chip Select Lines
- Programmable Strobe Options:
  - Individual read and write strobes or read/write strobe with enable strobe
- Address Auto-Increment/Auto-Decrement
- Programmable Address/Data Multiplexing
- Programmable Polarity on Control Signals
- Legacy Parallel Client Port Support
- Enhanced Parallel Client Support:
  - Address support
  - Four bytes deep, auto-incrementing buffer
- Schmitt Trigger or TTL Input Buffers
- Programmable Wait States
- Dual Buffer Mode with Separate Read and Write Registers
- Read Initiate Control

**FIGURE 19-1: PMP MODULE PINOUT AND CONNECTIONS TO EXTERNAL DEVICES**



# dsPIC33CK256MP508 FAMILY

## 19.1 PMP Control Registers

**REGISTER 19-1: PMCON: PMP CONTROL REGISTER**

R/W-0	U-0	R/W-0	R/W-0	R/W-0	R/W-0	R/W-0	R/W-0
ON	—	SIDL	ADRMUX1	ADRMUX0	PMP TTL	PTWREN	PTRDEN
bit 15							bit 8

R/W-0	R/W-0	R/W-0	R/W-0	R/W-0	U-0	R/W-0	R/W-0
CSF1 <sup>(1)</sup>	CSF0 <sup>(1)</sup>	ALP <sup>(1)</sup>	CS2P <sup>(1)</sup>	CS1P <sup>(1)</sup>	—	WRSP	RDSP
bit 7							bit 0

**Legend:**

R = Readable bit	W = Writable bit	U = Unimplemented bit, read as '0'
-n = Value at POR	'1' = Bit is set	'0' = Bit is cleared
		x = Bit is unknown

- bit 15      **ON:** PMP Enable bit  
1 = PMP is enabled  
0 = PMP is disabled, no off-chip access performed
- bit 14      **Unimplemented:** Read as '0'
- bit 13      **SIDL:** PMP Stop in Idle Mode bit  
1 = Discontinues module operation when device enters Idle mode  
0 = Continues module operation in Idle mode
- bit 12-11   **ADRMUX[1:0]:** Address/Data Multiplexing Selection bits  
11 = All 16 bits of address are multiplexed with the 16 bits of data (PMPA[15:0]/PMPD[15:0]) using two phases  
10 = All 16 bits of address are multiplexed with the lower 8 bits of data (PMPA[15:8]/PMPA[7:0]/PMPD[7:0]) using three phases  
01 = Lower 8 bits of address are multiplexed with lower 8 bits of data (PMPA[7:0]/PMPD[7:0])  
00 = Address and data appear on separate pins
- bit 10      **PMP TTL:** PMP Module TTL Input Buffer Select bit  
1 = PMP module uses TTL input buffers  
0 = PMP module uses Schmitt Trigger input buffers
- bit 9        **PTWREN:** PMP Write Enable Strobe Port Enable bit  
1 = PMWR/PMENB port is enabled  
0 = PMWR/PMENB port is disabled
- bit 8        **PTRDEN:** PMP Read/Write Strobe Port Enable bit  
1 = PMRD/PMWR port is enabled  
0 = PMRD/PMWR port is disabled
- bit 7-6     **CSF[1:0]:** Chip Select Function bits<sup>(1)</sup>  
11 = Reserved  
10 = PMCS2 and PMCS1 function as Chip Select  
01 = PMCS2 functions as Chip Select, PMCS1 functions as address bit  
00 = PMCS2 and PMCS1 function as address bits
- bit 5        **ALP:** Address Latch Polarity bit<sup>(1)</sup>  
1 = Active-high (PMALL and PMALH)  
0 = Active-low (PMALL and PMALH)
- bit 4        **CS2P:** Chip Select 2 Polarity bit<sup>(1)</sup>  
1 = Active-high  
0 = Active-low

**Note 1:** These bits have no effect when their corresponding pins are used as address lines.

# dsPIC33CK256MP508 FAMILY

---

## REGISTER 19-1: PMCON: PMP CONTROL REGISTER (CONTINUED)

bit 3	<b>CS1P:</b> Chip Select 1 Polarity bit <sup>(1)</sup> 1 = Active-high 0 = Active-low
bit 2	<b>Unimplemented:</b> Read as '0'
bit 1	<b>WRSP:</b> Write Strobe Polarity bit <u>For Client Modes and Host Mode 2 (MODE[1:0] (PMMODE[9:8]) = 00, 01, 10):</u> 1 = Write strobe is active-high (PMWR) 0 = Write strobe is active-low (PMWR) <u>For Host Mode 1 (MODE[1:0] (PMMODE[9:8]) = 11):</u> 1 = Enables strobe active-high (PMENB) 0 = Enables strobe active-low (PMENB)
bit 0	<b>RDSP:</b> Read Strobe Polarity bit <u>For Client Modes and Host Mode 2 (MODE[1:0] (PMMODE[9:8]) = 00, 01, 10):</u> 1 = Read strobe is active-high (PMRD) 0 = Read strobe is active-low (PMRD) <u>For Host Mode 1 (MODE[1:0] (PMMODE[9:8]) = 11):</u> 1 = Read/write strobe is active-high (PMRD/PMWR) 0 = Read/write strobe is active-low (PMRD/PMWR)

**Note 1:** These bits have no effect when their corresponding pins are used as address lines.

# dsPIC33CK256MP508 FAMILY

## REGISTER 19-2: PMCONH: PMP CONTROL HIGH REGISTER

U-0	U-0	U-0	U-0	U-0	U-0	U-0	U-0
—	—	—	—	—	—	—	—
bit 15							bit 8

R/W/HC-0	U-0	U-0	U-0	U-0	U-0	R/W-0	U-0
RDSTART <sup>(1)</sup>	—	—	—	—	—	DUALBUF	—
bit 7						bit 0	

<b>Legend:</b>	HC = Hardware Clearable bit
R = Readable bit	W = Writable bit
-n = Value at POR	'1' = Bit is set
	'0' = Bit is cleared
	x = Bit is unknown

bit 15-8 **Unimplemented:** Read as '0'

bit 7 **RDSTART:** Start a Read on PMP Bus bit<sup>(1)</sup>

1 = Starts a read cycle on the PMP bus

0 = No effect

bit 6-2 **Unimplemented:** Read as '0'

bit 1 **DUALBUF:** PMP Dual Read/Write Buffers Enable bit (valid in Host mode only)

1 = PMP uses separate registers for reads and writes (PMRADDR, PMDINx, PMWADDR, PMDOUTx)

0 = PMP uses legacy registers (PMADDR, PMDINx)

bit 0 **Unimplemented:** Read as '0'

**Note 1:** This bit is cleared by HW at the end of the read cycle when BUSY (PMMODE[15]) = 0.



# dsPIC33CK256MP508 FAMILY

## REGISTER 19-3: PMMODE: PMP MODE REGISTER

R/HS/HC-0	R/W-0	R/W-0	R/W-0	R/W-0	R/W-0	R/W-0	R/W-0
BUSY	IRQM1	IRQM0	INCM1	INCM0	MODE16	MODE1	MODE0
bit 15							bit 8

R/W-0	R/W-0	R/W-0	R/W-0	R/W-0	R/W-0	R/W-0	R/W-0
WAITB1 <sup>(1)</sup>	WAITB0 <sup>(1)</sup>	WAITM3 <sup>(1)</sup>	WAITM2 <sup>(1)</sup>	WAITM1 <sup>(1)</sup>	WAITM0 <sup>(1)</sup>	WAITE1 <sup>(1)</sup>	WAITE0 <sup>(1)</sup>
bit 7							bit 0

<b>Legend:</b>	HC = Hardware Clearable bit	HS = Hardware Settable bit
R = Readable bit	W = Writable bit	U = Unimplemented bit, read as '0'
-n = Value at POR	'1' = Bit is set	'0' = Bit is cleared
		x = Bit is unknown

bit 15 **BUSY:** Busy bit (Host mode only)

- 1 = Port is busy
- 0 = Port is not busy

bit 14-13 **IRQM[1:0]:** Interrupt Request Mode bits

- 11 = Reserved, do not use
- 10 = Interrupt generated when Read Buffer 3 is read or Write Buffer 3 is written (Buffered PSP mode), or on a read or write operation when PMA[1:0] = 11 (Addressable Client mode only)
- 01 = Interrupt generated at the end of the read/write cycle
- 00 = No Interrupt generated

bit 12-11 **INCM[1:0]:** Increment Mode bits

- 11 = Client mode read and write buffers auto-increment (MODE[1:0] (PMODE[9:8]) = 00 only)
- 10 = Decrements ADDR[15:0] by 1 every read/write cycle<sup>(2,4)</sup>
- 01 = Increments ADDR[15:0] by 1 every read/write cycle<sup>(2,4)</sup>
- 00 = No increment or decrement of address

bit 10 **MODE16:** 8/16-Bit Mode bit

- 1 = 16-Bit Mode: A read or write to the Data register invokes a single 16-bit transfer
- 0 = 8-Bit Mode: A read or write to the Data register invokes a single 8-bit transfer

bit 9-8 **MODE[1:0]:** PMP Mode Select bits

- 11 = Host Mode 1 (PMCSx, PMRD/PMWR, PMENB, PMA[x:0], PMD[7:0] and PMD[8:15]<sup>(3)</sup>)
- 10 = Host Mode 2 (PMCSx, PMRD, PMWR, PMA[x:0], PMD[7:0] and PMD[8:15]<sup>(3)</sup>)
- 01 = Enhanced Client mode, controls signals (PMRD, PMWR, PMCS, PMD[7:0] and PMA[1:0])
- 00 = Legacy Parallel Client Port, controls signals (PMRD, PMWR, PMCS and PMD[7:0])

bit 7-6 **WAITB[1:0]:** Data Setup to Read/Write Strobe Wait States bits<sup>(1)</sup>

- 11 = Data Wait of 4 TP; multiplexed address phase of 4 TP
- 10 = Data Wait of 3 TP; multiplexed address phase of 3 TP
- 01 = Data Wait of 2 TP; multiplexed address phase of 2 TP
- 00 = Data Wait of 1 TP; multiplexed address phase of 1 TP (**default**)

**Note 1:** When WAITM[3:0] = 0000, the WAITBx and WAITEx bits are ignored and forced to 1 TP (peripheral clock) cycle for a write operation; WAITBx = 1 TP cycle, WAITEx = 0 TP cycles for a read operation.

**2:** Address bits, A15 and A14, are not subject to auto-increment/decrement if configured as Chip Select, CS2 and CS1.

**3:** These pins are active when MODE16 = 1 (16-bit mode).

**4:** The PMADDR register is always incremented/decremented by 1 regardless of the transfer data width.

# dsPIC33CK256MP508 FAMILY

---

## REGISTER 19-3: PMMODE: PMP MODE REGISTER (CONTINUED)

- bit 5-2      **WAITM[3:0]:** Data Read/Write Strobe Wait States bits<sup>(1)</sup>  
1111 = Wait of 16 TP  
•  
•  
0001 = Wait of 2 TP  
0000 = Wait of 1 TP **(default)**
- bit 1-0      **WAITE[1:0]:** Data Hold After Read/Write Strobe Wait States bits<sup>(1)</sup>  
11 = Wait of 4 TP  
10 = Wait of 3 TP  
01 = Wait of 2 TP  
00 = Wait of 1 TP **(default)**
- For Read Operations:  
11 = Wait of 3 TP  
10 = Wait of 2 TP  
01 = Wait of 1 TP  
00 = Wait of 0 TP **(default)**

- Note 1:** When WAITM[3:0] = 0000, the WAITBx and WAITE<sub>x</sub> bits are ignored and forced to 1 TP (peripheral clock) cycle for a write operation; WAITB<sub>x</sub> = 1 TP cycle, WAITE<sub>x</sub> = 0 TP cycles for a read operation.
- 2:** Address bits, A15 and A14, are not subject to auto-increment/decrement if configured as Chip Select, CS2 and CS1.
- 3:** These pins are active when MODE16 = 1 (16-bit mode).
- 4:** The PMADDR register is always incremented/decremented by 1 regardless of the transfer data width.

# dsPIC33CK256MP508 FAMILY

## REGISTER 19-4: PMADDR: PMP ADDRESS REGISTER

R/W-0	R/W-0	R/W-0	R/W-0	R/W-0	R/W-0	R/W-0	R/W-0
CS2 <sup>(1)</sup>	CS1 <sup>(1)</sup>	ADDR[13:8]					
ADDR15 <sup>(1)</sup>	ADDR14 <sup>(1)</sup>						
bit 15							bit 8

R/W-0	R/W-0	R/W-0	R/W-0	R/W-0	R/W-0	R/W-0	R/W-0
ADDR[7:0]							
bit 7							bit 0

### Legend:

R = Readable bit                      W = Writable bit                      U = Unimplemented bit, read as '0'  
 -n = Value at POR                      '1' = Bit is set                      '0' = Bit is cleared                      x = Bit is unknown

- bit 15            **CS2:** Chip Select 2 bit<sup>(1)</sup>  
                   1 = Chip Select 2 is active  
                   0 = Chip Select 2 is inactive (ADDR15 function is selected)
- bit 15            **ADDR15:** Target Address bit 15<sup>(1)</sup>
- bit 14            **CS1:** Chip Select 1 bit<sup>(1)</sup>  
                   1 = Chip Select 1 is active  
                   0 = Chip Select 1 is inactive (ADDR14 function is selected)
- bit 14            **ADDR14:** Target Address bit 14<sup>(1)</sup>
- bit 13-0        **ADDR[13:0]:** Target Address bits

**Note 1:** The use of these pins as PMA15/PMA14 or CS2/CS1 is selected by the CSF[1:0] bits (PMCON[7:6]).

# dsPIC33CK256MP508 FAMILY

---

## REGISTER 19-5: PMDOUT1: PMP DATA OUTPUT LOW REGISTER

R/W-0	R/W-0	R/W-0	R/W-0	R/W-0	R/W-0	R/W-0	R/W-0
DATAOUT[15:8]							
bit 15							bit 8

R/W-0	R/W-0	R/W-0	R/W-0	R/W-0	R/W-0	R/W-0	R/W-0
DATAOUT[7:0]							
bit 7							bit 0

### Legend:

R = Readable bit                      W = Writable bit                      U = Unimplemented bit, read as '0'  
-n = Value at POR                      '1' = Bit is set                      '0' = Bit is cleared                      x = Bit is unknown

bit 15-0      **DATAOUT[15:0]:** Output Data Port bits  
These bits are for 8-bit read operations in Client mode and write operations for Dual Buffer Host mode.

## REGISTER 19-6: PMDOUT2: PMP DATA OUTPUT HIGH REGISTER

R/W-0	R/W-0	R/W-0	R/W-0	R/W-0	R/W-0	R/W-0	R/W-0
DATAOUT[31:24]							
bit 15							bit 8

R/W-0	R/W-0	R/W-0	R/W-0	R/W-0	R/W-0	R/W-0	R/W-0
DATAOUT[23:16]							
bit 7							bit 0

### Legend:

R = Readable bit                      W = Writable bit                      U = Unimplemented bit, read as '0'  
-n = Value at POR                      '1' = Bit is set                      '0' = Bit is cleared                      x = Bit is unknown

bit 15-0      **DATAOUT[31:16]:** Output Data Port bits  
These bits are for 8-bit write operations in Client mode.

# dsPIC33CK256MP508 FAMILY

## REGISTER 19-7: PMDIN1: PMP DATA INPUT/OUTPUT LOW REGISTER

R/W-0	R/W-0	R/W-0	R/W-0	R/W-0	R/W-0	R/W-0	R/W-0
DATAIN[15:8]							
bit 15				bit 8			

R/W-0	R/W-0	R/W-0	R/W-0	R/W-0	R/W-0	R/W-0	R/W-0
DATAIN[7:0]							
bit 7				bit 0			

**Legend:**

R = Readable bit	W = Writable bit	U = Unimplemented bit, read as '0'
-n = Value at POR	'1' = Bit is set	'0' = Bit is cleared      x = Bit is unknown

bit 15-0      **DATAIN[15:0]:** Input/Output Data Port bits  
 These bits are for 8-bit or 16-bit read/write operations in Host mode and are the input data port for 8-bit write operations in Client mode.

## REGISTER 19-8: PMDIN2: PMP DATA INPUT/OUTPUT HIGH REGISTER

R/W-0	R/W-0	R/W-0	R/W-0	R/W-0	R/W-0	R/W-0	R/W-0
DATAIN[31:24]							
bit 15				bit 8			

R/W-0	R/W-0	R/W-0	R/W-0	R/W-0	R/W-0	R/W-0	R/W-0
DATAIN[23:16]							
bit 7				bit 0			

**Legend:**

R = Readable bit	W = Writable bit	U = Unimplemented bit, read as '0'
-n = Value at POR	'1' = Bit is set	'0' = Bit is cleared      x = Bit is unknown

bit 15-0      **DATAIN[31:16]:** Input/Output Data Port bits  
 These bits are for 8-bit write operations in Client mode.

# dsPIC33CK256MP508 FAMILY

## REGISTER 19-9: PMAEN: PMP PIN ENABLE REGISTER

R/W-0	R/W-0	R/W-0	R/W-0	R/W-0	R/W-0	R/W-0	R/W-0
PTEN[15:14]		PTEN[13:8]					
bit 15		bit 8					

R/W-0	R/W-0	R/W-0	R/W-0	R/W-0	R/W-0	R/W-0	R/W-0
PTEN[7:2]					PTEN[1:0]		
bit 7					bit 0		

### Legend:

R = Readable bit                      W = Writable bit                      U = Unimplemented bit, read as '0'  
 -n = Value at POR                      '1' = Bit is set                      '0' = Bit is cleared                      x = Bit is unknown

- bit 15-14      **PTEN[15:14]:** PMCSx Strobe Enable bits  
                   1 = PMA15 and PMA14 function as either PMA[15:14] or PMCS2 and PMCS1<sup>(1)</sup>  
                   0 = PMA15 and PMA14 function as port I/Os
- bit 13-2      **PTEN[13:2]:** PMP Address Port Enable bits  
                   1 = PMA[13:2] function as PMP address lines  
                   0 = PMA[13:2] function as port I/Os
- bit 1-0      **PTEN[1:0]:** PMALH/PMALL Strobe Enable bits  
                   1 = PMA1 and PMA0 function as either PMA[1:0] or PMALH and PMALL<sup>(2)</sup>  
                   0 = PMA1 and PMA0 pads function as port I/Os

- Note 1:** The use of these pins as address or Chip Select lines is selected by the CSF[1:0] bits (PMCON[7:6]).  
**Note 2:** The use of these pins as PMA1/PMA0 or PMALH/PMALL depends on the Address/Data Multiplex mode selected by the ADRMUX[1:0] bits in the PMCON register.

# dsPIC33CK256MP508 FAMILY

## REGISTER 19-10: PMSTAT: PMP STATUS REGISTER (CLIENT MODES ONLY)

R-0	R/W-0	U-0	U-0	R-0	R-0	R-0	R-0
IBF	IBOV	—	—	IB3F	IB2F	IB1F	IB0F
bit 15							bit 8

R-1	R/W-0	U-0	U-0	R-1	R-1	R-1	R-1
OBE	OBUF	—	—	OB3E	OB2E	OB1E	OB0E
bit 7							bit 0

### Legend:

R = Readable bit                      W = Writable bit                      U = Unimplemented bit, read as '0'  
 -n = Value at POR                      '1' = Bit is set                      '0' = Bit is cleared                      x = Bit is unknown

- bit 15            **IBF:** Input Buffer Full Status bit  
 1 = All writable Input Buffer registers are full  
 0 = Some or all of the writable Input Buffer registers are empty
- bit 14            **IBOV:** Input Buffer Overflow Status bit  
 1 = A write attempt to a full input byte buffer occurred (must be cleared in software)  
 0 = No overflow occurred  
 This bit is set (= 1) in hardware; it can only be cleared (= 0) in software.
- bit 13-12       **Unimplemented:** Read as '0'
- bit 11-8        **IB[3:0]F:** Input Buffer x Status Full bits  
 1 = Input buffer contains data that have not been read (reading buffer will clear this bit)  
 0 = Input buffer does not contain any unread data
- bit 7            **OBE:** Output Buffer Empty Status bit  
 1 = All readable Output Buffer registers are empty  
 0 = Some or all of the readable Output Buffer registers are full
- bit 6            **OBUF:** Output Buffer Underflow Status bit  
 1 = A read occurred from an empty output byte buffer (must be cleared in software)  
 0 = No underflow occurred  
 This bit is set (= 1) in hardware; it can only be cleared (= 0) in software.
- bit 5-4        **Unimplemented:** Read as '0'
- bit 3-0        **OB[3:0]E:** Output Buffer x Status Empty bits  
 1 = Output buffer is empty (writing data to the buffer will clear this bit)  
 0 = Output buffer contains data that have not been transmitted

# dsPIC33CK256MP508 FAMILY

## REGISTER 19-11: PMWADDR: PMP WRITE ADDRESS REGISTER<sup>(2)</sup>

R/W-0	R/W-0	R/W-0	R/W-0	R/W-0	R/W-0	R/W-0	R/W-0
WCS2 <sup>(1)</sup>	WCS1 <sup>(1)</sup>	WADDR[13:8]					
WADDR15 <sup>(1)</sup>	WADDR14 <sup>(1)</sup>						
bit 15							bit 8

R/W-0	R/W-0	R/W-0	R/W-0	R/W-0	R/W-0	R/W-0	R/W-0
WADDR[7:0]							
bit 7							bit 0

<b>Legend:</b>							
R = Readable bit	W = Writable bit	U = Unimplemented bit, read as '0'					
-n = Value at POR	'1' = Bit is set	'0' = Bit is cleared	x = Bit is unknown				

- bit 15      **WCS2:** Chip Select 2 bit<sup>(1)</sup>  
             1 = Chip Select 2 is active  
             0 = Chip Select 2 is inactive (WADDR15 function is selected)
- bit 15      **WADDR15:** Target Write Address bit 15<sup>(1)</sup>
- bit 14      **WCS1:** Chip Select 1 bit<sup>(1)</sup>  
             1 = Chip Select 1 is active  
             0 = Chip Select 1 is inactive (WADDR14 function is selected)
- bit 14      **WADDR14:** Target Write Address bit 14<sup>(1)</sup>
- bit 13-0    **WADDR[13:0]:** Target Write Address bits

**Note 1:** The use of these pins as PMA15/PMA14 or WCS2/WCS1 is selected by the CSF[1:0] bits (PMCON[7:6]).  
**Note 2:** This register is only used when the DUALBUF bit (PMCONH[1]) is set to '1'.



# dsPIC33CK256MP508 FAMILY

## REGISTER 19-12: PMRADDR: PMP READ ADDRESS REGISTER<sup>(2)</sup>

R/W-0	R/W-0	R/W-0	R/W-0	R/W-0	R/W-0	R/W-0	R/W-0
RCS2 <sup>(1)</sup>	RCS1 <sup>(1)</sup>	RADDR[13:8]					
RADDR15 <sup>(1)</sup>	RADDR14 <sup>(1)</sup>						
bit 15							bit 8

R/W-0	R/W-0	R/W-0	R/W-0	R/W-0	R/W-0	R/W-0	R/W-0
RADDR[7:0]							
bit 7							bit 0

### Legend:

R = Readable bit                      W = Writable bit                      U = Unimplemented bit, read as '0'  
 -n = Value at POR                      '1' = Bit is set                      '0' = Bit is cleared                      x = Bit is unknown

- bit 15            **RCS2:** Chip Select 2 bit<sup>(1)</sup>  
                   1 = Chip Select 2 is active  
                   0 = Chip Select 2 is inactive (RADDR15 function is selected)
- bit 15            **RADDR15:** Target Read Address bit 15<sup>(1)</sup>
- bit 14            **RCS1:** Chip Select 1 bit<sup>(1)</sup>  
                   1 = Chip Select 1 is active  
                   0 = Chip Select 1 is inactive (RADDR14 function is selected)
- bit 14            **RADDR14:** Target Read Address bit 14<sup>(1)</sup>
- bit 13-0        **RADDR[13:0]:** Target Read Address bits

- Note 1:** The use of these pins as PMA15/PMA14 or RCS2/RCS1 is selected by the CSF[1:0] bits (PMCON[7:6]).  
**2:** This register is only used when the DUALBUF bit (PMCONH[1]) is set to '1'.

# dsPIC33CK256MP508 FAMILY

## REGISTER 19-13: PMRDIN: PMP READ INPUT DATA REGISTER<sup>(1)</sup>

R/W-0	R/W-0	R/W-0	R/W-0	R/W-0	R/W-0	R/W-0	R/W-0
RDATAIN[15:8] <sup>(2)</sup>							
bit 15							
bit 8							

R/W-0	R/W-0	R/W-0	R/W-0	R/W-0	R/W-0	R/W-0	R/W-0
RDATAIN[7:0] <sup>(2)</sup>							
bit 7							
bit 0							

### Legend:

R = Readable bit

W = Writable bit

U = Unimplemented bit, read as '0'

-n = Value at POR

'1' = Bit is set

'0' = Bit is cleared

x = Bit is unknown

bit 15-0      **RDATAIN[15:0]:** Port Read Input Data bits<sup>(2)</sup>

**Note 1:** This register is only used when the DUALBUF bit (PMCONH[1]) is set to '1' and exclusively for reads. If the DUALBUF bit is '0', the PMDIN1 register ([Register 19-7](#)) is used for reads instead of PMRDIN.

**2:** Only used when MODE16 = 1.

## 20.0 SINGLE-EDGE NIBBLE TRANSMISSION (SENT)

**Note 1:** This data sheet summarizes the features of this group of dsPIC33CK256MP508 family devices. It is not intended to be a comprehensive reference source. To complement the information in this data sheet, refer to “**Single-Edge Nibble Transmission (SENT) Module**” ([www.microchip.com/DS70005145](http://www.microchip.com/DS70005145)) in the “*dsPIC33/PIC24 Family Reference Manual*”.

The Single-Edge Nibble Transmission (SENT) module is based on the SAE J2716, “*SENT – Single-Edge Nibble Transmission for Automotive Applications*”. The SENT protocol is a one-way, single wire time modulated serial communication, based on successive falling edges. It is intended for use in applications where high-resolution sensor data need to be communicated from a sensor to an Engine Control Unit (ECU).

The SENTx module has the following major features:

- Selectable Transmit or Receive mode
- Synchronous or Asynchronous Transmit modes
- Automatic Data Rate Synchronization
- Optional Automatic Detection of CRC Errors in Receive mode
- Optional Hardware Calculation of CRC in Transmit mode
- Support for Optional Pause Pulse Period
- Data Buffering for One Message Frame
- Selectable Data Length for Transmit/Receive, Up to Six Nibbles
- Automatic Detection of Framing Errors

SENT protocol timing is based on a predetermined time unit,  $T_{TICK}$ . Both the transmitter and receiver must be preconfigured for  $T_{TICK}$ , which can vary from 3 to 90  $\mu$ s. A SENT message frame starts with a Sync pulse. The purpose of the Sync pulse is to allow the receiver to calculate the data rate of the message encoded by the transmitter. The SENT specification allows messages to be validated with up to a 20% variation in  $T_{TICK}$ . This allows for the transmitter and receiver to run from different clocks that may be inaccurate, and drift with time and temperature. The data nibbles are 4 bits in length and are encoded as the data value + 12 ticks. This yields a 0 value of 12 ticks and the maximum value, 0xF, of 27 ticks.

A SENT message consists of the following:

- A synchronization/calibration period of 56 tick times
- A status nibble of 12-27 tick times
- Up to six data nibbles of 12-27 tick times
- A CRC nibble of 12-27 tick times
- An optional pause pulse period of 12-768 tick times

Figure 20-1 shows a block diagram of the SENTx module.

Figure 20-2 shows the construction of a typical 6-nibble data frame, with the numbers representing the minimum or maximum number of tick times for each section.

# dsPIC33CK256MP508 FAMILY

FIGURE 20-1: SENTx MODULE BLOCK DIAGRAM

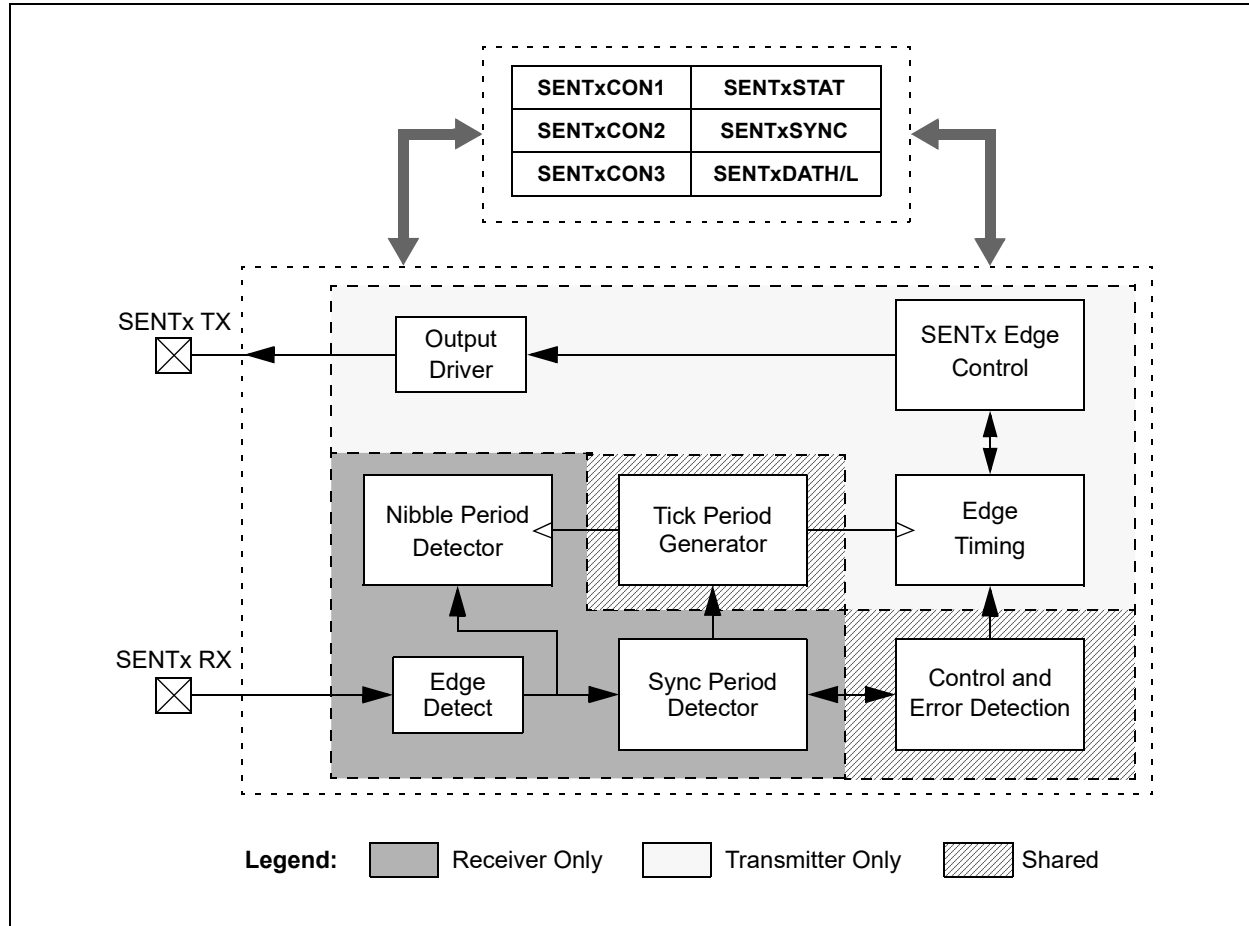
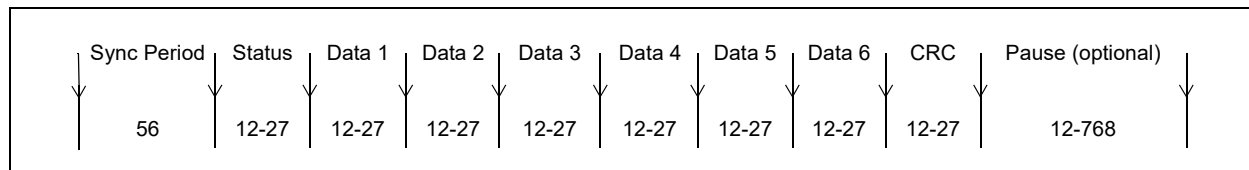


FIGURE 20-2: SENTx PROTOCOL DATA FRAMES



## 20.1 Transmit Mode

By default, the SENTx module is configured for transmit operation. The module can be configured for continuous asynchronous message frame transmission, or alternatively, for Synchronous mode triggered by software. When enabled, the transmitter will send a Sync, followed by the appropriate number of data nibbles, an optional CRC and optional pause pulse. The tick period used by the SENTx transmitter is set by writing a value to the TICKTIME[15:0] (SENTxCON2[15:0]) bits. The tick period calculations are shown in [Equation 20-1](#).

### EQUATION 20-1: TICK PERIOD CALCULATION

$$TICKTIME[15:0] = \frac{T_{TICK}}{T_{CLK}} - 1$$

An optional pause pulse can be used in Asynchronous mode to provide a fixed message frame time period. The frame period used by the SENTx transmitter is set by writing a value to the FRAMETIME[15:0] (SENTxCON3[15:0]) bits. The formulas used to calculate the value of frame time are shown in [Equation 20-2](#).

### EQUATION 20-2: FRAME TIME CALCULATIONS

$$FRAMETIME[15:0] = T_{TICK}/T_{FRAME}$$

$$FRAMETIME[15:0] \geq 122 + 27N$$

$$FRAMETIME[15:0] \geq 848 + 12N$$

Where:

$T_{FRAME}$  = Total time of the message from ms

$N$  = The number of data nibbles in message, 1-6

**Note:** The module will not produce a pause period with less than 12 ticks, regardless of the FRAMETIME[15:0] value. FRAMETIME[15:0] values beyond 2047 will have no effect on the length of a data frame.

## 20.1.1 TRANSMIT MODE CONFIGURATION

### 20.1.1.1 Initializing the SENTx Module

Perform the following steps to initialize the module:

1. Write RCVEN (SENTxCON1[11]) = 0 for Transmit mode.
2. Write TXM (SENTxCON1[10]) = 0 for Asynchronous Transmit mode or TXM = 1 for Synchronous mode.
3. Write NIBCNT[2:0] (SENTxCON1[2:0]) for the desired data frame length.
4. Write CRCEN (SENTxCON1[8]) for hardware or software CRC calculation.
5. Write PPP (SENTxCON1[7]) for optional pause pulse.
6. If PPP = 1, write TFRAME to SENTxCON3.
7. Write SENTxCON2 with the appropriate value for the desired tick period.
8. Enable interrupts and set interrupt priority.
9. Write initial status and data values to SENTxDATH/L.
10. If CRCEN = 0, calculate CRC and write the value to CRC[3:0] (SENTxDATL[3:0]).
11. Set the SNTEN (SENTxCON1[15]) bit to enable the module.

User software updates to SENTxDATH/L must be performed after the completion of the CRC and before the next message frame's status nibble. The recommended method is to use the message frame completion interrupt to trigger data writes.

# dsPIC33CK256MP508 FAMILY

## 20.2 Receive Mode

The module can be configured for receive operation by setting the RCVEN (SENTxCON1[11]) bit. The time between each falling edge is compared to SYNCMIN[15:0] (SENTxCON3[15:0]) and SYNCMAX[15:0] (SENTxCON2[15:0]), and if the measured time lies between the minimum and maximum limits, the module begins to receive data. The validated Sync time is captured in the SENTxSYNC register and the tick time is calculated. Subsequent falling edges are verified to be within the valid data width and the data are stored in the SENTxDATL/H registers. An interrupt event is generated at the completion of the message and the user software should read the SENTx Data registers before the reception of the next nibble. The equation for SYNCMIN[15:0] and SYNCMAX[15:0] is shown in Equation 20-3.

### EQUATION 20-3: SYNCMIN[15:0] AND SYNCMAX[15:0] CALCULATIONS

$$TICK = TCLK \cdot (TICKTIME[15:0] + 1)$$

$$FRAMETIME[15:0] = TICK/TFRAME$$

$$SyncCount = 8 \times FRCV \times TICK$$

$$SYNCMIN[15:0] = 0.8 \times SyncCount$$

$$SYNCMAX[15:0] = 1.2 \times SyncCount$$

$$FRAMETIME[15:0] \geq 122 + 27N$$

$$FRAMETIME[15:0] \geq 848 + 12N$$

Where:

$TFRAME$  = Total time of the message from ms

$N$  = The number of data nibbles in message, 1-6

$FRCV$  =  $FCY \times$  Prescaler

$TCLK$  =  $FCY/$ Prescaler

For  $TICK = 3.0 \mu s$  and  $FCLK = 4 \text{ MHz}$ ,  $SYNCMIN[15:0] = 76$ .

**Note:** To ensure a Sync period can be identified, the value written to SYNCMIN[15:0] must be less than the value written to SYNCMAX[15:0].

## 20.2.1 RECEIVE MODE CONFIGURATION

### 20.2.1.1 Initializing the SENTx Module

Perform the following steps to initialize the module:

1. Write RCVEN (SENTxCON1[11]) = 1 for Receive mode.
2. Write NIBCNT[2:0] (SENTxCON1[2:0]) for the desired data frame length.
3. Write CRCEN (SENTxCON1[8]) for hardware or software CRC validation.
4. Write PPP (SENTxCON1[7]) = 1 if pause pulse is present.
5. Write SENTxCON2 with the value of SYNCMAXx (Nominal Sync Period + 20%).
6. Write SENTxCON3 with the value of SYNCMINx (Nominal Sync Period – 20%).
7. Enable interrupts and set interrupt priority.
8. Set the SNTEN (SENTxCON1[15]) bit to enable the module.

The data should be read from the SENTxDATL/H registers after the completion of the CRC and before the next message frame's status nibble. The recommended method is to use the message frame completion interrupt trigger.

# dsPIC33CK256MP508 FAMILY

## 20.3 SENT Control Registers

### REGISTER 20-1: SENTxCON1: SENTx CONTROL REGISTER 1

R/W-0	U-0	R/W-0	U-0	R/W-0	R/W-0	R/W-0	R/W-0
SNTEN	—	SNTSIDL	—	RCVEN	TXM <sup>(1)</sup>	TXPOL <sup>(1)</sup>	CRCEN
bit 15							bit 8

R/W-0	R/W-0	U-0	R/W-0	U-0	R/W-0	R/W-0	R/W-0
PPP	SPCEN <sup>(2)</sup>	—	PS	—	NIBCNT2	NIBCNT1	NIBCNT0
bit 7							bit 0

#### Legend:

R = Readable bit	W = Writable bit	U = Unimplemented bit, read as '0'
-n = Value at POR	'1' = Bit is set	'0' = Bit is cleared
		x = Bit is unknown

- bit 15      **SNTEN:** SENTx Enable bit  
 1 = SENTx is enabled  
 0 = SENTx is disabled
- bit 14      **Unimplemented:** Read as '0'
- bit 13      **SNTSIDL:** SENTx Stop in Idle Mode bit  
 1 = Discontinues module operation when the device enters Idle mode  
 0 = Continues module operation in Idle mode
- bit 12      **Unimplemented:** Read as '0'
- bit 11      **RCVEN:** SENTx Receive Enable bit  
 1 = SENTx operates as a receiver  
 0 = SENTx operates as a transmitter (sensor)
- bit 10      **TXM:** SENTx Transmit Mode bit<sup>(1)</sup>  
 1 = SENTx transmits data frame only when triggered using the SYNCTXEN status bit  
 0 = SENTx transmits data frames continuously while SNTEN = 1
- bit 9      **TXPOL:** SENTx Transmit Polarity bit<sup>(1)</sup>  
 1 = SENTx data output pin is low in the Idle state  
 0 = SENTx data output pin is high in the Idle state
- bit 8      **CRCEN:** CRC Enable bit  
Module in Receive Mode (RCVEN = 1):  
 1 = SENTx performs CRC verification on received data using the preferred J2716 method  
 0 = SENTx does not perform CRC verification on received data  
Module in Transmit Mode (RCVEN = 1):  
 1 = SENTx automatically calculates CRC using the preferred J2716 method  
 0 = SENTx does not calculate CRC
- bit 7      **PPP:** Pause Pulse Present bit  
 1 = SENTx is configured to transmit/receive SENT messages with pause pulse  
 0 = SENTx is configured to transmit/receive SENT messages without pause pulse
- bit 6      **SPCEN:** Short PWM Code Enable bit<sup>(2)</sup>  
 1 = SPC control from external source is enabled  
 0 = SPC control from external source is disabled
- bit 5      **Unimplemented:** Read as '0'

- Note 1:** This bit has no function in Receive mode (RCVEN = 1).  
**Note 2:** This bit has no function in Transmit mode (RCVEN = 0).

# dsPIC33CK256MP508 FAMILY

---

## REGISTER 20-1: SENTxCON1: SENTx CONTROL REGISTER 1 (CONTINUED)

bit 4            **PS:** SENTx Module Clock Prescaler (divider) bits

1 = Divide-by-4

0 = Divide-by-1

bit 3            **Unimplemented:** Read as '0'

bit 2-0        **NIBCNT[2:0]:** Nibble Count Control bits

111 = Reserved; do not use

110 = Module transmits/receives six data nibbles in a SENT data packet

101 = Module transmits/receives five data nibbles in a SENT data packet

100 = Module transmits/receives four data nibbles in a SENT data packet

011 = Module transmits/receives three data nibbles in a SENT data packet

010 = Module transmits/receives two data nibbles in a SENT data packet

001 = Module transmits/receives one data nibble in a SENT data packet

000 = Reserved; do not use

**Note 1:** This bit has no function in Receive mode (RCVEN = 1).

**2:** This bit has no function in Transmit mode (RCVEN = 0).



# dsPIC33CK256MP508 FAMILY

## REGISTER 20-2: SENTxSTAT: SENTx STATUS REGISTER

U-0	U-0	U-0	U-0	U-0	U-0	U-0	U-0
—	—	—	—	—	—	—	—
bit 15							bit 8

R-0	R-0	R-0	R-0	R/C-0	R/C-0	R-0	HC/R/W-0
PAUSE	NIB2	NIB1	NIB0	CRCERR	FRMERR	RXIDLE	SYNCTXEN <sup>(1)</sup>
bit 7							bit 0

<b>Legend:</b>	C = Clearable bit	HC = Hardware Clearable bit
R = Readable bit	W = Writable bit	U = Unimplemented bit, read as '0'
-n = Value at POR	'1' = Bit is set	'0' = Bit is cleared      x = Bit is unknown

bit 15-8      **Unimplemented:** Read as '0'

bit 7      **PAUSE:** Pause Period Status bit

- 1 = The module is transmitting/receiving a pause period
- 0 = The module is not transmitting/receiving a pause period

bit 6-4      **NIB[2:0]:** Nibble Status bits

Module in Transmit Mode (RCVEN = 0):

- 111 = Module is transmitting a CRC nibble
- 110 = Module is transmitting Data Nibble 6
- 101 = Module is transmitting Data Nibble 5
- 100 = Module is transmitting Data Nibble 4
- 011 = Module is transmitting Data Nibble 3
- 010 = Module is transmitting Data Nibble 2
- 001 = Module is transmitting Data Nibble 1
- 000 = Module is transmitting a status nibble or pause period, or is not transmitting

Module in Receive Mode (RCVEN = 1):

- 111 = Module is receiving a CRC nibble or was receiving this nibble when an error occurred
- 110 = Module is receiving Data Nibble 6 or was receiving this nibble when an error occurred
- 101 = Module is receiving Data Nibble 5 or was receiving this nibble when an error occurred
- 100 = Module is receiving Data Nibble 4 or was receiving this nibble when an error occurred
- 011 = Module is receiving Data Nibble 3 or was receiving this nibble when an error occurred
- 010 = Module is receiving Data Nibble 2 or was receiving this nibble when an error occurred
- 001 = Module is receiving Data Nibble 1 or was receiving this nibble when an error occurred
- 000 = Module is receiving a status nibble or waiting for Sync

bit 3      **CRCERR:** CRC Status bit (Receive mode only)

- 1 = A CRC error has occurred for the 1-6 data nibbles in SENTxDATL/H
- 0 = A CRC error has not occurred

bit 2      **FRMERR:** Framing Error Status bit (Receive mode only)

- 1 = A data nibble was received with less than 12 tick periods or greater than 27 tick periods
- 0 = Framing error has not occurred

bit 1      **RXIDLE:** SENTx Receiver Idle Status bit (Receive mode only)

- 1 = The SENTx data bus has been Idle (high) for a period of SYNCMAX[15:0] or greater
- 0 = The SENTx data bus is not Idle

**Note 1:** In Receive mode (RCVEN = 1), the SYNCTXEN bit is read-only.

# dsPIC33CK256MP508 FAMILY

---

## REGISTER 20-2: SENTxSTAT: SENTx STATUS REGISTER (CONTINUED)

bit 0

**SYNCTXEN:** SENTx Synchronization Period Status/Transmit Enable bit<sup>(1)</sup>

Module in Receive Mode (RCVEN = 1):

1 = A valid synchronization period was detected; the module is receiving nibble data

0 = No synchronization period has been detected; the module is not receiving nibble data

Module in Asynchronous Transmit Mode (RCVEN = 0, TXM = 0):

The bit always reads as '1' when the module is enabled, indicating the module transmits SENTx data frames continuously. The bit reads '0' when the module is disabled.

Module in Synchronous Transmit Mode (RCVEN = 0, TXM = 1):

1 = The module is transmitting a SENTx data frame

0 = The module is not transmitting a data frame, user software may set SYNCTXEN to start another data frame transmission

**Note 1:** In Receive mode (RCVEN = 1), the SYNCTXEN bit is read-only.

# dsPIC33CK256MP508 FAMILY

## REGISTER 20-3: SENTxDATL: SENTx RECEIVE DATA REGISTER LOW<sup>(1)</sup>

R/W-0	R/W-0	R/W-0	R/W-0	R/W-0	R/W-0	R/W-0	R/W-0
DATA4[3:0]				DATA5[3:0]			
bit 15				bit 8			

R/W-0	R/W-0	R/W-0	R/W-0	R/W-0	R/W-0	R/W-0	R/W-0
DATA6[3:0]				CRC[3:0]			
bit 7				bit 0			

### Legend:

R = Readable bit                      W = Writable bit                      U = Unimplemented bit, read as '0'  
 -n = Value at POR                      '1' = Bit is set                      '0' = Bit is cleared                      x = Bit is unknown

bit 15-12      **DATA4[3:0]:** Data Nibble 4 Data bits  
 bit 11-8      **DATA5[3:0]:** Data Nibble 5 Data bits  
 bit 7-4      **DATA6[3:0]:** Data Nibble 6 Data bits  
 bit 3-0      **CRC[3:0]:** CRC Nibble Data bits

**Note 1:** Register bits are read-only in Receive mode (RCVEN = 1). In Transmit mode, the CRC[3:0] bits are read-only when automatic CRC calculation is enabled (RCVEN = 0, CRCEN = 1).

## REGISTER 20-4: SENTxDATH: SENTx RECEIVE DATA REGISTER HIGH<sup>(1)</sup>

R/W-0	R/W-0	R/W-0	R/W-0	R/W-0	R/W-0	R/W-0	R/W-0
STAT[3:0]				DATA1[3:0]			
bit 15				bit 8			

R/W-0	R/W-0	R/W-0	R/W-0	R/W-0	R/W-0	R/W-0	R/W-0
DATA2[3:0]				DATA3[3:0]			
bit 7				bit 0			

### Legend:

R = Readable bit                      W = Writable bit                      U = Unimplemented bit, read as '0'  
 -n = Value at POR                      '1' = Bit is set                      '0' = Bit is cleared                      x = Bit is unknown

bit 15-12      **STAT[3:0]:** Status Nibble Data bits  
 bit 11-8      **DATA1[3:0]:** Data Nibble 1 Data bits  
 bit 7-4      **DATA2[3:0]:** Data Nibble 2 Data bits  
 bit 3-0      **DATA3[3:0]:** Data Nibble 3 Data bits

**Note 1:** Register bits are read-only in Receive mode (RCVEN = 1). In Transmit mode, the CRC[3:0] bits are read-only when automatic CRC calculation is enabled (RCVEN = 0, CRCEN = 1).

# dsPIC33CK256MP508 FAMILY

---

NOTES:

# dsPIC33CK256MP508 FAMILY

## 21.0 TIMER1

**Note 1:** This data sheet summarizes the features of the dsPIC33CK256MP508 family of devices. It is not intended to be a comprehensive reference source. To complement the information in this data sheet, refer to “**Timer1 Module**” ([www.microchip.com/DS70005279](http://www.microchip.com/DS70005279)) in the “dsPIC33/PIC24 Family Reference Manual”.

The Timer1 module is a 16-bit timer that can operate as a free-running interval timer/counter.

The Timer1 module has the following unique features over other timers:

- Can be Operated in Asynchronous Counter mode
- Asynchronous Timer
- Operational during CPU Sleep mode
- Software Selectable Prescalers 1:1, 1:8, 1:64 and 1:256
- External Clock Selection Control
- The Timer1 External Clock Input (T1CK) can Optionally be Synchronized to the Internal Device Clock and the Clock Synchronization is Performed after the Prescaler

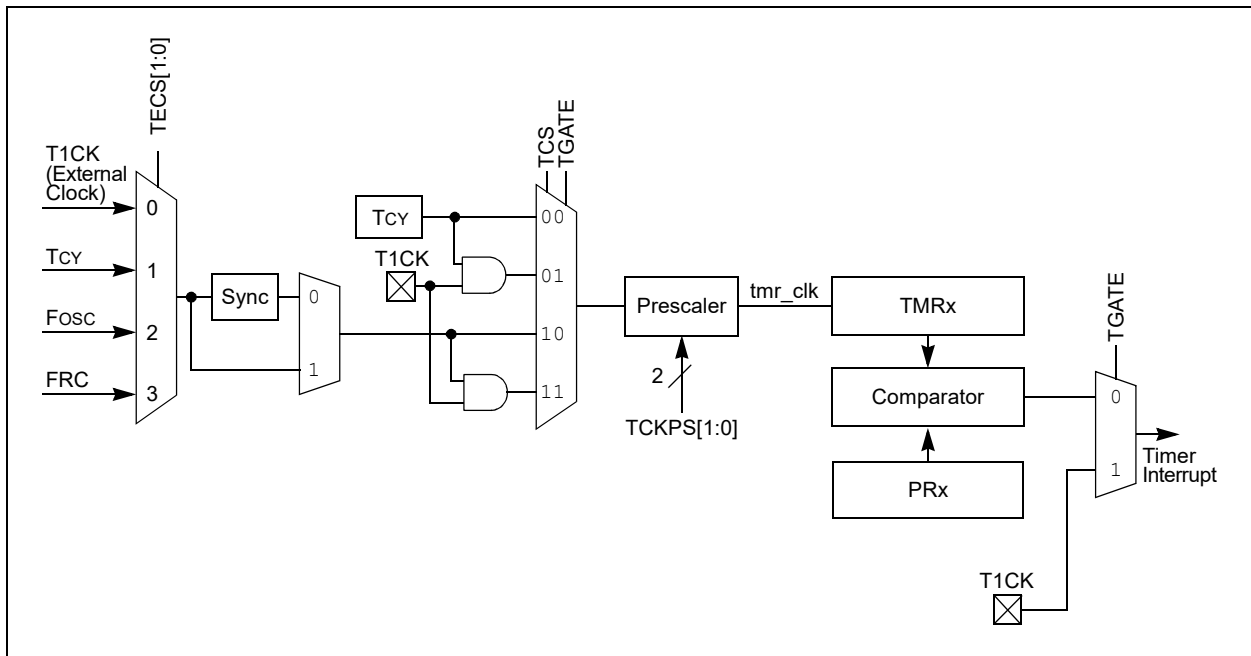
If Timer1 is used for SCCP, the timer should be running in Synchronous mode.

The Timer1 module can operate in one of the following modes:

- Timer mode
- Gated Timer mode
- Synchronous Counter mode
- Asynchronous Counter mode

A block diagram of Timer1 is shown in [Figure 21-1](#).

**FIGURE 21-1: 16-BIT TIMER1 MODULE BLOCK DIAGRAM**



# dsPIC33CK256MP508 FAMILY

## 21.1 Timer1 Control Register

**REGISTER 21-1: T1CON: TIMER1 CONTROL REGISTER**

R/W-0	U-0	R/W-0	R/W-0	R-0	R-0	R/W-0	R/W-0
TON <sup>(1)</sup>	—	SIDL	TMWDIS	TMWIP	PRWIP	TECS1	TECS0
bit 15							bit 8

R/W-0	U-0	R/W-0	R/W-0	U-0	R/W-0	R/W-0	U-0
TGATE	—	TCKPS1	TCKPS0	—	TSYNC <sup>(1)</sup>	TCS <sup>(1)</sup>	—
bit 7							bit 0

**Legend:**

R = Readable bit	W = Writable bit	U = Unimplemented bit, read as '0'
-n = Value at POR	'1' = Bit is set	'0' = Bit is cleared
		x = Bit is unknown

- bit 15      **TON:** Timer1 On bit<sup>(1)</sup>  
1 = Starts 16-bit Timer1  
0 = Stops 16-bit Timer1
- bit 14      **Unimplemented:** Read as '0'
- bit 13      **SIDL:** Timer1 Stop in Idle Mode bit  
1 = Discontinues module operation when device enters Idle mode  
0 = Continues module operation in Idle mode
- bit 12      **TMWDIS:** Asynchronous Timer1 Write Disable bit  
1 = Timer writes are ignored while a posted write to TMR1 or PR1 is synchronized to the asynchronous clock domain  
0 = Back-to-back writes are enabled in Asynchronous mode
- bit 11      **TMWIP:** Asynchronous Timer1 Write in Progress bit  
1 = Write to the timer in Asynchronous mode is pending  
0 = Write to the timer in Asynchronous mode is complete
- bit 10      **PRWIP:** Asynchronous Period Write in Progress bit  
1 = Write to the Period register in Asynchronous mode is pending  
0 = Write to the Period register in Asynchronous mode is complete
- bit 9-8     **TECS[1:0]:** Timer1 Extended Clock Select bits  
11 = FRC clock  
10 = Fosc  
01 = Tcy  
00 = External Clock comes from the T1CK pin
- bit 7      **TGATE:** Timer1 Gated Time Accumulation Enable bit  
When TCS = 1:  
This bit is ignored.  
When TCS = 0:  
1 = Gated time accumulation is enabled  
0 = Gated time accumulation is disabled
- bit 6      **Unimplemented:** Read as '0'

**Note 1:** When Timer1 is enabled in External Synchronous Counter mode (TCS = 1, TSYNC = 1, TON = 1), any attempts by user software to write to the TMR1 register are ignored.

# dsPIC33CK256MP508 FAMILY

---

## REGISTER 21-1: T1CON: TIMER1 CONTROL REGISTER (CONTINUED)

- bit 5-4      **TCKPS[1:0]:** Timer1 Input Clock Prescale Select bits  
11 = 1:256  
10 = 1:64  
01 = 1:8  
00 = 1:1
- bit 3      **Unimplemented:** Read as '0'
- bit 2      **TSYNC:** Timer1 External Clock Input Synchronization Select bit<sup>(1)</sup>  
When TCS = 1:  
1 = Synchronizes the External Clock input  
0 = Does not synchronize the External Clock input  
When TCS = 0:  
This bit is ignored.
- bit 1      **TCS:** Timer1 Clock Source Select bit<sup>(1)</sup>  
1 = External Clock source selected by TECS[1:0]  
0 = Internal peripheral clock (FP)
- bit 0      **Unimplemented:** Read as '0'

**Note 1:** When Timer1 is enabled in External Synchronous Counter mode (TCS = 1, TSYNC = 1, TON = 1), any attempts by user software to write to the TMR1 register are ignored.

# dsPIC33CK256MP508 FAMILY

---

NOTES:



## 22.0 CAPTURE/COMPARE/PWM/TIMER MODULES (SCCP/MCCP)

**Note 1:** This data sheet summarizes the features of the dsPIC33CK256MP508 family of devices. It is not intended to be a comprehensive reference source. For more information on the MCCP/SCCP modules, refer to “**Capture/Compare/PWM/Timer (MCCP and SCCP)**” ([www.microchip.com/DS30003035](http://www.microchip.com/DS30003035)) in the “dsPIC33/PIC24 Family Reference Manual”.

dsPIC33CK256MP508 family devices include eight SCCP and one MCCP Capture/Compare/PWM/Timer base modules, which provide the functionality of three different peripherals from earlier PIC24F devices. The module can operate in one of three major modes:

- General Purpose Timer
- Input Capture
- Output Compare/PWM

The module is provided in two different forms, distinguished by the number of PWM outputs that the module can generate. Single Capture/Compare/PWM (SCCP) output modules provide only one PWM output.

Multiple Capture/Compare/PWM (MCCP) output modules can provide up to six outputs and an extended range of power control features, depending on the pin count of the particular device. All other features of the modules are identical.

The SCCPx and MCCPx modules can be operated in only one of the three major modes at any time. The other modes are not available unless the module is reconfigured for the new mode.

A conceptual block diagram for the module is shown in [Figure 22-1](#). All three modes share a time base generator and a common Timer register pair (CCPxTMRH/L); other shared hardware components are added as a particular mode requires.

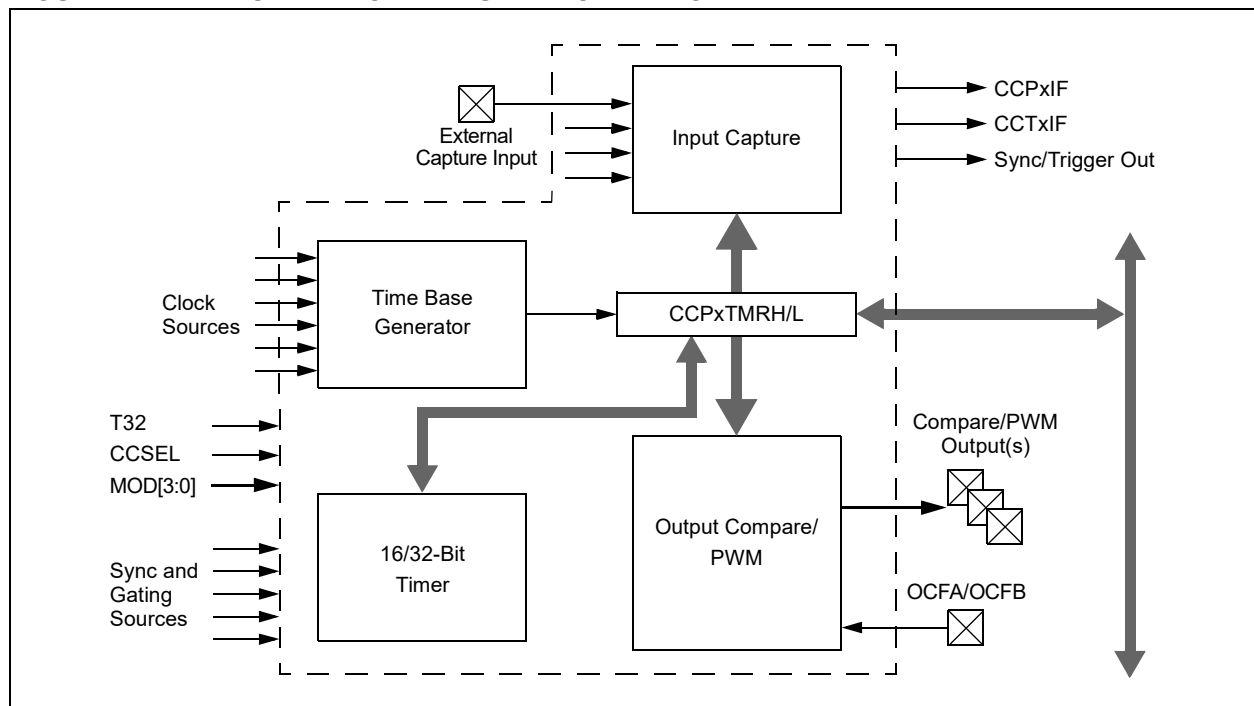
Each module has a total of six control and status registers:

- CCPxCON1L ([Register 22-1](#))
- CCPxCON1H ([Register 22-2](#))
- CCPxCON2L ([Register 22-3](#))
- CCPxCON2H ([Register 22-4](#))
- CCPxCON3H ([Register 22-6](#))
- CCPxSTATL ([Register 22-7](#))

Each module also includes eight buffer/counter registers that serve as Timer Value registers or data holding buffers:

- CCPxTMRH/CCPxTMRL (CCPx Timer High/Low Counters)
- CCPxPRH/CCPxPRL (CCPx Timer Period High/Low)
- CCPxRA (CCPx Primary Output Compare Data Buffer)
- CCPxRB (CCPx Secondary Output Compare Data Buffer)
- CCPxBUFH/CCPxBUFL (CCPx Input Capture High/Low Buffers)

**FIGURE 22-1: SCCPx CONCEPTUAL BLOCK DIAGRAM**



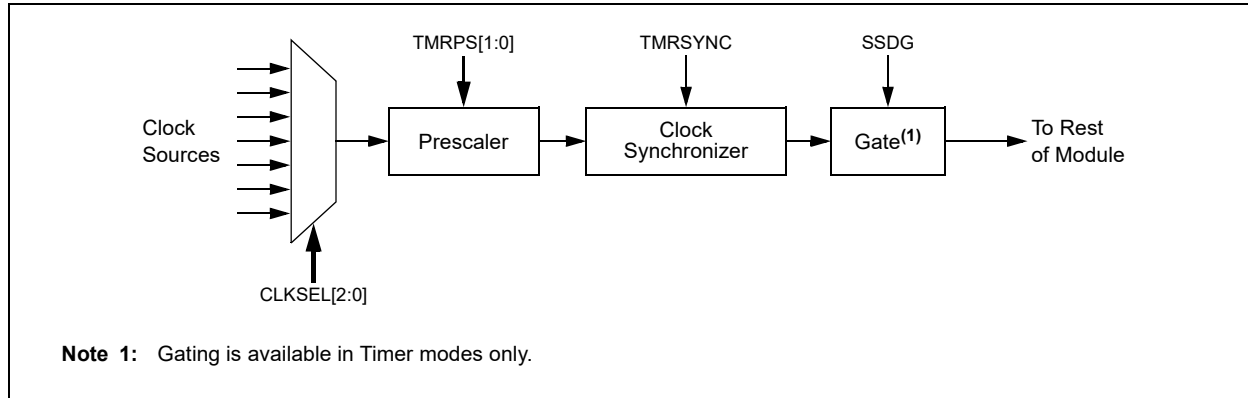
# dsPIC33CK256MP508 FAMILY

## 22.1 Time Base Generator

The Timer Clock Generator (TCG) generates a clock for the module's internal time base, using one of the clock signals already available on the microcontroller. This is used as the time reference for the module in its three major modes. The internal time base is shown in Figure 22-2.

There are eight inputs available to the clock generator, which are selected using the CLKSEL[2:0] bits (CCPxCON1L[10:8]). Available sources include the FRC and LPRC, the Secondary Oscillator and the TCLKI External Clock inputs. The system clock is the default source (CLKSEL[2:0] = 000).

**FIGURE 22-2: TIMER CLOCK GENERATOR**



## 22.2 General Purpose Timer

Timer mode is selected when CCSEL = 0 and MOD[3:0] = 0000. The timer can function as a 32-bit timer or a dual 16-bit timer, depending on the setting of the T32 bit (Table 22-1).

**TABLE 22-1: TIMER OPERATION MODE**

T32 (CCPxCON1L[5])	Operating Mode
0	Dual Timer Mode (16-bit)
1	Timer Mode (32-bit)

Dual 16-Bit Timer mode provides a simple timer function with two independent 16-bit timer/counters. The primary timer uses CCPxTMRL and CCPxPRL. Only the primary timer can interact with other modules on the device. It generates the SCCPx sync out signals for use by other SCCP modules. It can also use the SYNC[4:0] bits signal generated by other modules.

The secondary timer uses CCPxTMRH and CCPxPRH. It is intended to be used only as a periodic interrupt source for scheduling CPU events. It does not generate an output sync/trigger signal like the primary time base. In Dual Timer mode, the CCPx Secondary Timer Period register, CCPxPRH, generates the SCCP compare event (CCPxIF) used by many other modules on the device.

The 32-Bit Timer mode uses the CCPxTMRL and CCPxTMRH registers, together, as a single 32-bit timer. When CCPxTMRL overflows, CCPxTMRH increments by one. This mode provides a simple timer function when it is important to track long time periods. Note that

the T32 bit (CCPxCON1L[5]) should be set before the CCPxTMRL or CCPxPRH registers are written to initialize the 32-bit timer.

### 22.2.1 SYNC AND TRIGGER OPERATION

In both 16-bit and 32-bit modes, the timer can also function in either synchronization ("sync") or trigger operation. Both use the SYNC[4:0] bits (CCPxCON1H[4:0]) to determine the input signal source. The difference is how that signal affects the timer.

In sync operation, the timer Reset or clear occurs when the input selected by SYNC[4:0] is asserted. The timer immediately begins to count again from zero unless it is held for some other reason. Sync operation is used whenever the TRIGEN bit (CCPxCON1H[7]) is cleared. SYNC[4:0] can have any value, except '11111'.

In trigger operation, the timer is held in Reset until the input selected by SYNC[4:0] is asserted; when it occurs, the timer starts counting. Trigger operation is used whenever the TRIGEN bit is set. In Trigger mode, the timer will continue running after a trigger event as long as the CCPTRIG bit (CCPxSTATL[7]) is set. To clear CCPTRIG, the TRCLR bit (CCPxSTATL[5]) must be set to clear the trigger event, reset the timer and hold it at zero until another trigger event occurs. On dsPIC33CK256MP508 family devices, trigger operation can only be used when the system clock is the time base source (CLKSEL[2:0] = 000).

# dsPIC33CK256MP508 FAMILY

## 22.3 Output Compare Mode

Output Compare mode compares the Timer register value with the value of one or two Compare registers, depending on its mode of operation. The Output Compare x module, on compare match events, has the ability to generate a single output transition or a train of

output pulses. Like most PIC® MCU peripherals, the Output Compare x module can also generate interrupts on a compare match event.

Table 22-2 shows the various modes available in Output Compare modes.

**TABLE 22-2: OUTPUT COMPARE x/PWMx MODES**

MOD[3:0] (CCPxCON1L[3:0])	T32 (CCPxCON1L[5])	Operating Mode	
0001	0	Output High on Compare (16-bit)	Single Edge Mode
0001	1	Output High on Compare (32-bit)	
0010	0	Output Low on Compare (16-bit)	
0010	1	Output Low on Compare (32-bit)	
0011	0	Output Toggle on Compare (16-bit)	
0011	1	Output Toggle on Compare (32-bit)	
0100	0	Dual Edge Compare (16-bit)	Dual Edge Mode
0101	0	Dual Edge Compare (16-bit buffered)	PWM Mode

## 22.4 Input Capture Mode

Input Capture mode is used to capture a timer value from an independent timer base, upon an event, on an input pin or other internal trigger source. The input capture features are useful in applications requiring frequency (time period) and pulse measurement.

Input Capture mode uses a dedicated 16/32-bit, synchronous, up counting timer for the capture function. The timer value is written to the FIFO when a capture event occurs. The internal value may be read (with a synchronization delay) using the CCPxTMRH/L register.

To use Input Capture mode, the CCSEL bit (CCPxCON1L[4]) must be set. The T32 and the MOD[3:0] bits are used to select the proper Capture mode, as shown in Table 22-3.

**TABLE 22-3: INPUT CAPTURE x MODES**

MOD[3:0] (CCPxCON1L[3:0])	T32 (CCPxCON1L[5])	Operating Mode
0000	0	Edge Detect (16-bit capture)
0000	1	Edge Detect (32-bit capture)
0001	0	Every Rising (16-bit capture)
0001	1	Every Rising (32-bit capture)
0010	0	Every Falling (16-bit capture)
0010	1	Every Falling (32-bit capture)
0011	0	Every Rising/Falling (16-bit capture)
0011	1	Every Rising/Falling (32-bit capture)
0100	0	Every 4th Rising (16-bit capture)
0100	1	Every 4th Rising (32-bit capture)
0101	0	Every 16th Rising (16-bit capture)
0101	1	Every 16th Rising (32-bit capture)

# dsPIC33CK256MP508 FAMILY

## 22.5 Auxiliary Output

The SCCPx modules have an auxiliary (secondary) output that provides other peripherals access to internal module signals. The auxiliary output is intended to connect to other SCCP modules, or other digital peripherals, to provide these types of functions:

- Time Base Synchronization
- Peripheral Trigger and Clock Inputs
- Signal Gating

The type of output signal is selected using the AUXOUT[1:0] control bits (CCPxCON2H[4:3]). The type of output signal is also dependent on the module operating mode.

**TABLE 22-4: AUXILIARY OUTPUT**

AUXOUT[1:0]	CCSEL	MOD[3:0]	Comments	Signal Description
00	x	xxxx	Auxiliary output disabled	No Output
01	0	0000	Time Base modes	Time Base Period Reset or Rollover
10				Special Event Trigger Output
11				No Output
01	0	0001 through 1111	Output Compare modes	Time Base Period Reset or Rollover
10				Output Compare Event Signal
11				Output Compare Signal
01	1	xxxx	Input Capture modes	Time Base Period Reset or Rollover
10				Reflects the Value of the ICDIS bit
11				Input Capture Event Signal

# dsPIC33CK256MP508 FAMILY

## 22.6 SCCP/MCCP Control Registers

**REGISTER 22-1: CCPxCON1L: CCPx CONTROL 1 LOW REGISTERS**

R/W-0	U-0	R/W-0	R/W-0	R/W-0	R/W-0	R/W-0	R/W-0
CCPON	—	CCPSIDL	CCPSLP	TMRSYNC	CLKSEL2	CLKSEL1	CLKSEL0
bit 15							bit 8

R/W-0	R/W-0	R/W-0	R/W-0	R/W-0	R/W-0	R/W-0	R/W-0
TMRPS1	TMRPS0	T32	CCSEL	MOD3	MOD2	MOD1	MOD0
bit 7							bit 0

**Legend:**

R = Readable bit	W = Writable bit	U = Unimplemented bit, read as '0'
-n = Value at POR	'1' = Bit is set	'0' = Bit is cleared
		x = Bit is unknown

- bit 15      **CCPON:** CCPx Module Enable bit  
1 = Module is enabled with an operating mode specified by the MOD[3:0] control bits  
0 = Module is disabled
- bit 14      **Unimplemented:** Read as '0'
- bit 13      **CCPSIDL:** CCPx Stop in Idle Mode Bit  
1 = Discontinues module operation when device enters Idle mode  
0 = Continues module operation in Idle mode
- bit 12      **CCPSLP:** CCPx Sleep Mode Enable bit  
1 = Module continues to operate in Sleep modes  
0 = Module does not operate in Sleep modes
- bit 11      **TMRSYNC:** Time Base Clock Synchronization bit  
1 = Asynchronous module time base clock is selected and synchronized to the internal system clocks (CLKSEL[2:0] ≠ 000)  
0 = Synchronous module time base clock is selected and does not require synchronization (CLKSEL[2:0] = 000)
- bit 10-8    **CLKSEL[2:0]:** CCPx Time Base Clock Select bits  
111 = PPS TxCK input  
110 = CLC4  
101 = CLC3  
100 = CLC2  
011 = CLC1  
010 = FOSC  
001 = Reference Clock (REFCLKO)  
000 = Fosc/2 (Fp)
- bit 7-6     **TMRPS[1:0]:** Time Base Prescale Select bits  
11 = 1:64 Prescaler  
10 = 1:16 Prescaler  
01 = 1:4 Prescaler  
00 = 1:1 Prescaler
- bit 5       **T32:** 32-Bit Time Base Select bit  
1 = Uses 32-bit time base for timer, single edge output compare or input capture function  
0 = Uses 16-bit time base for timer, single edge output compare or input capture function
- bit 4       **CCSEL:** Capture/Compare Mode Select bit  
1 = Input Capture peripheral  
0 = Output Compare/PWM/Timer peripheral (exact function is selected by the MOD[3:0] bits)

**Note 1:** Center-Aligned mode is only available in MCCP (CCP9).

# dsPIC33CK256MP508 FAMILY

---

## REGISTER 22-1: CCPxCON1L: CCPx CONTROL 1 LOW REGISTERS (CONTINUED)

bit 3-0      **MOD[3:0]:** CCPx Mode Select bits

For CCSEL = 1 (Input Capture modes):

- 1xxx = Reserved
- 011x = Reserved
- 0101 = Capture every 16th rising edge
- 0100 = Capture every 4th rising edge
- 0011 = Capture every rising and falling edge
- 0010 = Capture every falling edge
- 0001 = Capture every rising edge
- 0000 = Capture every rising and falling edge (Edge Detect mode)

For CCSEL = 0 (Output Compare/Timer modes):

- 1111 = External Input mode: Pulse generator is disabled, source is selected by ICS[2:0]
- 1110 = Reserved
- 110x = Reserved
- 10xx = Reserved
- 0111 = Reserved
- 0110 = Center-Aligned PWM mode, buffered<sup>(1)</sup>
- 0101 = Dual Edge Compare mode, buffered
- 0100 = Dual Edge Compare mode
- 0011 = 16-Bit/32-Bit Single Edge mode, toggles output on compare match
- 0010 = 16-Bit/32-Bit Single Edge mode, drives output low on compare match
- 0001 = 16-Bit/32-Bit Single Edge mode, drives output high on compare match
- 0000 = 16-Bit/32-Bit Timer mode, output functions are disabled

**Note 1:** Center-Aligned mode is only available in M CCP (CCP9).

# dsPIC33CK256MP508 FAMILY

## REGISTER 22-2: CCPxCON1H: CCPx CONTROL 1 HIGH REGISTERS

R/W-0	R/W-0	U-0	U-0	R/W-0	R/W-0	R/W-0	R/W-0
OPSSRC <sup>(1)</sup>	RTRGEN <sup>(2)</sup>	—	—	OPS3 <sup>(3)</sup>	OPS2 <sup>(3)</sup>	OPS1 <sup>(3)</sup>	OPS0 <sup>(3)</sup>
bit 15							bit 8

R/W-0	R/W-0	R/W-0	R/W-0	R/W-0	R/W-0	R/W-0	R/W-0
TRIGEN	ONESHOT	ALTSYNC	SYNC4	SYNC3	SYNC2	SYNC1	SYNC0
bit 7							bit 0

### Legend:

R = Readable bit                      W = Writable bit                      U = Unimplemented bit, read as '0'  
 -n = Value at POR                      '1' = Bit is set                      '0' = Bit is cleared                      x = Bit is unknown

- bit 15      **OPSSRC:** Output Postscaler Source Select bit<sup>(1)</sup>  
             1 = Output postscaler scales module trigger output events  
             0 = Output postscaler scales time base interrupt events
- bit 14      **RTRGEN:** Retrigger Enable bit<sup>(2)</sup>  
             1 = Time base can be retriggered when TRIGEN bit = 1  
             0 = Time base may not be retriggered when TRIGEN bit = 1
- bit 13-12   **Unimplemented:** Read as '0'
- bit 11-8    **OPS3[3:0]:** CCPx Interrupt Output Postscale Select bits<sup>(3)</sup>  
             1111 = Interrupt every 16th time base period match  
             1110 = Interrupt every 15th time base period match  
             ...  
             0100 = Interrupt every 5th time base period match  
             0011 = Interrupt every 4th time base period match or 4th input capture event  
             0010 = Interrupt every 3rd time base period match or 3rd input capture event  
             0001 = Interrupt every 2nd time base period match or 2nd input capture event  
             0000 = Interrupt after each time base period match or input capture event
- bit 7        **TRIGEN:** CCPx Trigger Enable bit  
             1 = Trigger operation of time base is enabled  
             0 = Trigger operation of time base is disabled
- bit 6        **ONESHOT:** One-Shot Trigger Mode Enable bit  
             1 = One-Shot Trigger mode is enabled; trigger duration is set by OSCNT[2:0]  
             0 = One-Shot Trigger mode is disabled
- bit 5        **ALTSYNC:** CCPx Alternate Synchronization Output Signal Select bit  
             1 = An alternate signal is used as the module synchronization output signal  
             0 = The module synchronization output signal is the Time Base Reset/rollover event
- bit 4-0      **SYNC[4:0]:** CCPx Synchronization Source Select bits  
             See [Table 22-5](#) for the definition of inputs.

- Note 1:** This control bit has no function in Input Capture modes.  
**Note 2:** This control bit has no function when TRIGEN = 0.  
**Note 3:** Output postscale settings, from 1:5 to 1:16 (0100-1111), will result in a FIFO buffer overflow for Input Capture modes.

# dsPIC33CK256MP508 FAMILY

---

**TABLE 22-5: SYNCHRONIZATION SOURCES**

<b>SYNC[4:0]</b>	<b>Synchronization Source</b>
00000	None; Timer with Rollover on CCPxPR Match or FFFFh
00001	Module's Own Timer Sync Out
00010	Sync Output SCCP2
00011	Sync Output SCCP3
00100	Sync Output SCCP4
00101	Sync Output SCCP5
00110	Sync Output SCCP6
00111	Sync Output SCCP7
01000	Sync Output SCCP8
01001	INT0
01010	INT1
01011	INT2
01100	UART1 RX Edge Detect
01101	UART1 TX Edge Detect
01110	UART2 RX Edge Detect
01111	UART2 TX Edge Detect
10000	CLC1 Output
10001	CLC2 Output
10010	CLC3 Output
10011	CLC4 Output
10100	UART3 RX Edge Detect
10101	UART3 TX Edge Detect
10110	Sync Output M CCP9
10111	Comparator 1 Output
11000	Comparator 2 Output
11001	Comparator 3 Output
11010-11110	Reserved
11111	None; Timer with Auto-Rollover (FFFFh → 0000h)



# dsPIC33CK256MP508 FAMILY

**REGISTER 22-3: CCPxCON2L: CCPx CONTROL 2 LOW REGISTERS**

R/W-0	R/W-0	U-0	R/W-0	U-0	U-0	U-0	U-0
PWMRSEN	ASDGM	—	SSDG	—	—	—	—
bit 15							bit 8

R/W-0	R/W-0	R/W-0	R/W-0	R/W-0	R/W-0	R/W-0	R/W-0
ASDG[7:0]							
bit 7							bit 0

**Legend:**

R = Readable bit                      W = Writable bit                      U = Unimplemented bit, read as '0'  
 -n = Value at POR                      '1' = Bit is set                      '0' = Bit is cleared                      x = Bit is unknown

- bit 15            **PWMRSEN:** CCPx PWM Restart Enable bit  
                   1 = ASEVT bit clears automatically at the beginning of the next PWM period, after the shutdown input has ended  
                   0 = ASEVT bit must be cleared in software to resume PWM activity on output pins
- bit 14            **ASDGM:** CCPx Auto-Shutdown Gate Mode Enable bit  
                   1 = Waits until the next Time Base Reset or rollover for shutdown to occur  
                   0 = Shutdown event occurs immediately
- bit 13            **Unimplemented:** Read as '0'
- bit 12            **SSDG:** CCPx Software Shutdown/Gate Control bit  
                   1 = Manually forces auto-shutdown, timer clock gate or input capture signal gate event (setting of ASDGM bit still applies)  
                   0 = Normal module operation
- bit 11-8        **Unimplemented:** Read as '0'
- bit 7-0         **ASDG[7:0]:** CCPx Auto-Shutdown/Gating Source Enable bits  
                   1 = ASDGx Source n is enabled (see [Table 22-6](#) for auto-shutdown/gating sources)  
                   0 = ASDGx Source n is disabled

**TABLE 22-6: AUTO-SHUTDOWN AND GATING SOURCES**

ASDG[x] Bit	Auto-Shutdown/Gating Source								
	SCCP1	SCCP2	SCCP3	SCCP4	SCCP5	SCCP6	SCCP7	SCCP8	MCCP9
0	Comparator 1 Output								
1	Comparator 2 Output								
2	OCFC								
3	OCFD								
4	ICM1 <sup>(1)</sup>	ICM2 <sup>(1)</sup>	ICM3 <sup>(1)</sup>	ICM4 <sup>(1)</sup>	ICM5 <sup>(1)</sup>	ICM6 <sup>(1)</sup>	ICM7 <sup>(1)</sup>	ICM8 <sup>(1)</sup>	ICM9 <sup>(1)</sup>
5	CLC1 <sup>(1)</sup>								
6	OCFA <sup>(1)</sup>								
7	OCFB <sup>(1)</sup>								

**Note 1:** Selected by Peripheral Pin Select (PPS).

# dsPIC33CK256MP508 FAMILY

## REGISTER 22-4: CCPxCON2H: CCPx CONTROL 2 HIGH REGISTERS

R/W-0	U-0	R/W-0	R/W-0	R/W-0	R/W-0	R/W-0	R/W-0
OENSYNC	—	OCFEN <sup>(1)</sup>	OCEEN <sup>(1)</sup>	OCDEN <sup>(1)</sup>	OCCEN <sup>(1)</sup>	OCBEN <sup>(1)</sup>	OCAEN
bit 15							bit 8

R/W-0	R/W-0	U-0	R/W-0	R/W-0	R/W-0	R/W-0	R/W-0
ICGSM1	ICGSM0	—	AUXOUT1	AUXOUT0	ICS2	ICS1	ICS0
bit 7							bit 0

### Legend:

R = Readable bit                      W = Writable bit                      U = Unimplemented bit, read as '0'  
 -n = Value at POR                      '1' = Bit is set                      '0' = Bit is cleared                      x = Bit is unknown

- bit 15            **OENSYNC:** Output Enable Synchronization bit  
 1 = Update by output enable bits occurs on the next Time Base Reset or rollover  
 0 = Update by output enable bits occurs immediately
- bit 14            **Unimplemented:** Read as '0'
- bit 13-8        **OC[F:A]EN:** Output Enable/Steering Control bits<sup>(1)</sup>  
 1 = OCMx pin is controlled by the CCPx module and produces an output compare or PWM signal  
 0 = OCMx pin is not controlled by the CCPx module; the pin is available to the port logic or another peripheral multiplexed on the pin
- bit 7-6         **ICGSM[1:0]:** Input Capture Gating Source Mode Control bits  
 11 = Reserved  
 10 = One-Shot mode: Falling edge from gating source disables future capture events (ICDIS = 1)  
 01 = One-Shot mode: Rising edge from gating source enables future capture events (ICDIS = 0)  
 00 = Level-Sensitive mode: A high level from gating source will enable future capture events; a low level will disable future capture events
- bit 5            **Unimplemented:** Read as '0'
- bit 4-3         **AUXOUT[1:0]:** Auxiliary Output Signal on Event Selection bits  
 11 = Input capture or output compare event; no signal in Timer mode  
 10 = Signal output is defined by module operating mode (see [Table 22-4](#))  
 01 = Time base rollover event (all modes)  
 00 = Disabled
- bit 2-0         **ICS[2:0]:** Input Capture Source Select bits  
 111 = CLC4 output  
 110 = CLC3 output  
 101 = CLC2 output  
 100 = CLC1 output  
 011 = Comparator 3 output  
 010 = Comparator 2 output  
 001 = Comparator 1 output  
 000 = SCCP Input Capture x (ICx) pin (PPS)

**Note 1:** OCFEN through OCBEN (bits[13:9]) are implemented in the MCCP9 module only.

# dsPIC33CK256MP508 FAMILY

**REGISTER 22-5: CCPxCON3L: CCPx CONTROL 3 LOW REGISTERS<sup>(1)</sup>**

U-0	U-0	U-0	U-0	U-0	U-0	U-0	U-0
—	—	—	—	—	—	—	—
bit 15						bit 8	

U-0	U-0	R/W-0	R/W-0	R/W-0	R/W-0	R/W-0	R/W-0
—	—	DT[5:0]					
bit 7						bit 0	

**Legend:**

R = Readable bit	W = Writable bit	U = Unimplemented bit, read as '0'
-n = Value at POR	'1' = Bit is set	'0' = Bit is cleared
		x = Bit is unknown

bit 15-6      **Unimplemented:** Read as '0'

bit 5-0      **DT[5:0]:** CCPx Dead-Time Select bits

111111 = Inserts 63 dead-time delay periods between complementary output signals

111110 = Inserts 62 dead-time delay periods between complementary output signals

...

000010 = Inserts 2 dead-time delay periods between complementary output signals

000001 = Inserts 1 dead-time delay period between complementary output signals

000000 = Dead-time logic is disabled

**Note 1:** This register is implemented in the MCCP9 module only.

# dsPIC33CK256MP508 FAMILY

## REGISTER 22-6: CCPxCON3H: CCPx CONTROL 3 HIGH REGISTERS

R/W-0	R/W-0	R/W-0	R/W-0	U-0	R/W-0	R/W-0	R/W-0
OETRIG	OSCNT2	OSCNT1	OSCNT0	—	OUTM2 <sup>(1)</sup>	OUTM1 <sup>(1)</sup>	OUTM0 <sup>(1)</sup>
bit 15							bit 8

U-0	U-0	R/W-0	R/W-0	R/W-0	R/W-0	R/W-0	R/W-0
—	—	POLACE	POLBDF <sup>(1)</sup>	PSSACE1	PSSACE0	PSSBDF1 <sup>(1)</sup>	PSSBDF0 <sup>(1)</sup>
bit 7							bit 0

### Legend:

R = Readable bit

W = Writable bit

U = Unimplemented bit, read as '0'

-n = Value at POR

'1' = Bit is set

'0' = Bit is cleared

x = Bit is unknown

- bit 15      **OETRIG:** CCPx Dead-Time Select bit  
 1 = For Triggered mode (TRIGEN = 1): Module does not drive enabled output pins until triggered  
 0 = Normal output pin operation
- bit 14-12    **OSCNT[2:0]:** One-Shot Event Count bits  
 111 = Extends one-shot event by seven time base periods (eight time base periods total)  
 110 = Extends one-shot event by six time base periods (seven time base periods total)  
 101 = Extends one-shot event by five time base periods (six time base periods total)  
 100 = Extends one-shot event by four time base periods (five time base periods total)  
 011 = Extends one-shot event by three time base periods (four time base periods total)  
 010 = Extends one-shot event by two time base periods (three time base periods total)  
 001 = Extends one-shot event by one time base period (two time base periods total)  
 000 = Does not extend one-shot Trigger event
- bit 11      **Unimplemented:** Read as '0'
- bit 10-8    **OUTM[2:0]:** PWMx Output Mode Control bits<sup>(1)</sup>  
 111 = Reserved  
 110 = Output Scan mode  
 101 = Brush DC Output mode, forward  
 100 = Brush DC Output mode, reverse  
 011 = Reserved  
 010 = Half-Bridge Output mode  
 001 = Push-Pull Output mode  
 000 = Steerable Single Output mode
- bit 7-6     **Unimplemented:** Read as '0'
- bit 5       **POLACE:** CCPx Output Pins, OCMxA, OCMxC and OCMxE, Polarity Control bit  
 1 = Output pin polarity is active-low  
 0 = Output pin polarity is active-high
- bit 4       **POLBDF:** CCPx Output Pins, OCMxB, OCMxD and OCMxF, Polarity Control bit<sup>(1)</sup>  
 1 = Output pin polarity is active-low  
 0 = Output pin polarity is active-high
- bit 3-2     **PSSACE[1:0]:** PWMx Output Pins, OCMxA, OCMxC and OCMxE, Shutdown State Control bits  
 11 = Pins are driven active when a shutdown event occurs  
 10 = Pins are driven inactive when a shutdown event occurs  
 0x = Pins are tri-stated when a shutdown event occurs
- bit 1-0     **PSSBDF[1:0]:** PWMx Output Pins, OCMxB, OCMxD, and OCMxF, Shutdown State Control bits<sup>(1)</sup>  
 11 = Pins are driven active when a shutdown event occurs  
 10 = Pins are driven inactive when a shutdown event occurs  
 0x = Pins are in a high-impedance state when a shutdown event occurs

**Note 1:** These bits are implemented in the MCCP9 module only.

# dsPIC33CK256MP508 FAMILY

## REGISTER 22-7: CCPxSTATL: CCPx STATUS REGISTER

U-0	U-0	U-0	U-0	U-0	W1-0	U-0	U-0
—	—	—	—	—	ICGARM	—	—
bit 15						bit 8	

R-0	W1-0	W1-0	R/C-0	R/C-0	R/C-0	R/C-0	R/C-0
CCPTRIG	TRSET	TRCLR	ASEVT	SCEVT	ICDIS	ICOV	ICBNE
bit 7							bit 0

<b>Legend:</b>	C = Clearable bit		
R = Readable bit	W1 = Write '1' Only bit	U = Unimplemented bit, read as '0'	
-n = Value at POR	'1' = Bit is set	'0' = Bit is cleared	x = Bit is unknown

bit 15-11 **Unimplemented:** Read as '0'

bit 10 **ICGARM:** Input Capture Gate Arm bit

A write of '1' to this location will arm the input capture gating logic for a one-shot gate event when ICGSM[1:0] = 01 or 10. Bit always reads as '0'.

bit 9-8 **Unimplemented:** Read as '0'

bit 7 **CCPTRIG:** CCPx Trigger Status bit

1 = Timer has been triggered and is running  
0 = Timer has not been triggered and is held in Reset

bit 6 **TRSET:** CCPx Trigger Set Request bit

Writes '1' to this location to trigger the timer when TRIGEN = 1 (location always reads as '0').

bit 5 **TRCLR:** CCPx Trigger Clear Request bit

Writes '1' to this location to cancel the timer trigger when TRIGEN = 1 (location always reads as '0').

bit 4 **ASEVT:** CCPx Auto-Shutdown Event Status/Control bit

1 = A shutdown event is in progress; CCPx outputs are in the shutdown state  
0 = CCPx outputs operate normally

bit 3 **SCEVT:** Single Edge Compare Event Status bit

1 = A single edge compare event has occurred  
0 = A single edge compare event has not occurred

bit 2 **ICDIS:** Input Capture x Disable bit

1 = Event on Input Capture x pin (ICx) does not generate a capture event  
0 = Event on Input Capture x pin will generate a capture event

bit 1 **ICOV:** Input Capture x Buffer Overflow Status bit

1 = The Input Capture x FIFO buffer has overflowed  
0 = The Input Capture x FIFO buffer has not overflowed

bit 0 **ICBNE:** Input Capture x Buffer Status bit

1 = Input Capture x buffer has data available  
0 = Input Capture x buffer is empty

# dsPIC33CK256MP508 FAMILY

---

NOTES:

# dsPIC33CK256MP508 FAMILY

## 23.0 CONFIGURABLE LOGIC CELL (CLC)

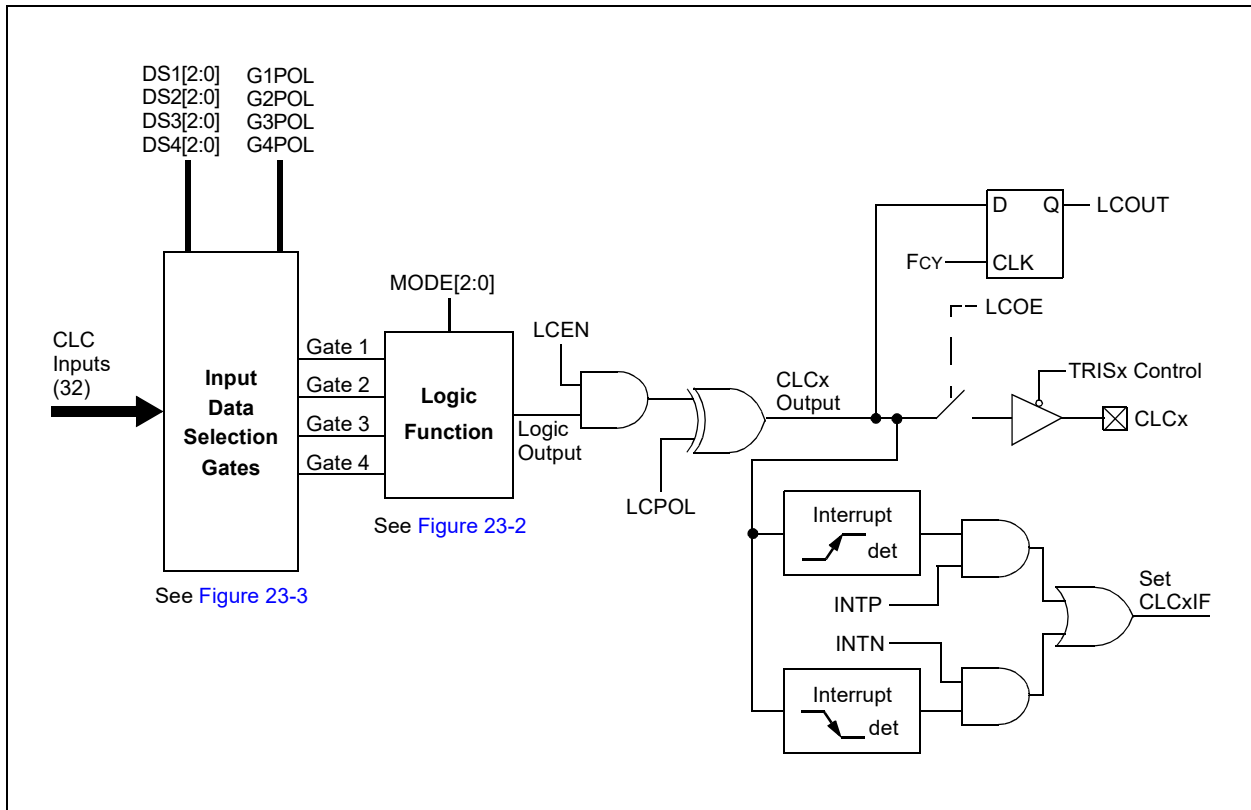
**Note 1:** This data sheet summarizes the features of the dsPIC33CK256MP508 family of devices. It is not intended to be a comprehensive reference source. For more information, refer to “Configurable Logic Cell (CLC)” ([www.microchip.com/DS70005298](http://www.microchip.com/DS70005298)) in the “dsPIC33/PIC24 Family Reference Manual”. The information in this data sheet supersedes the information in the FRM.

The Configurable Logic Cell (CLC) module allows the user to specify combinations of signals as inputs to a logic function and to use the logic output to control other peripherals or I/O pins. This provides greater flexibility and potential in embedded designs, since the CLC module can operate outside the limitations of software execution, and supports a vast amount of output designs.

There are four input gates to the selected logic function. These four input gates select from a pool of up to 32 signals that are selected using four data source selection multiplexers. Figure 23-1 shows an overview of the module.

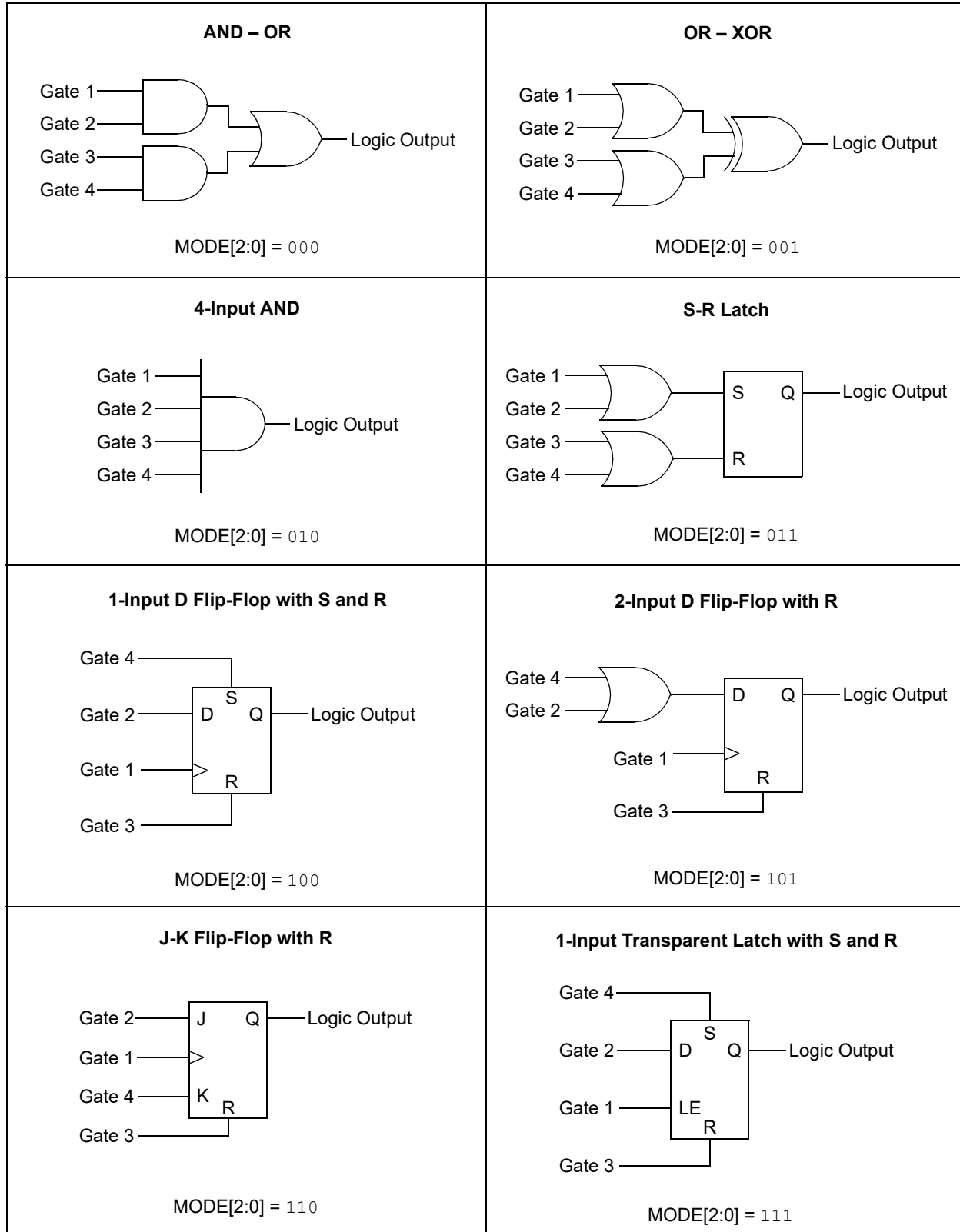
Figure 23-3 shows the details of the data source multiplexers and Figure 23-2 shows the logic input gate connections.

FIGURE 23-1: CLCx MODULE



# dsPIC33CK256MP508 FAMILY

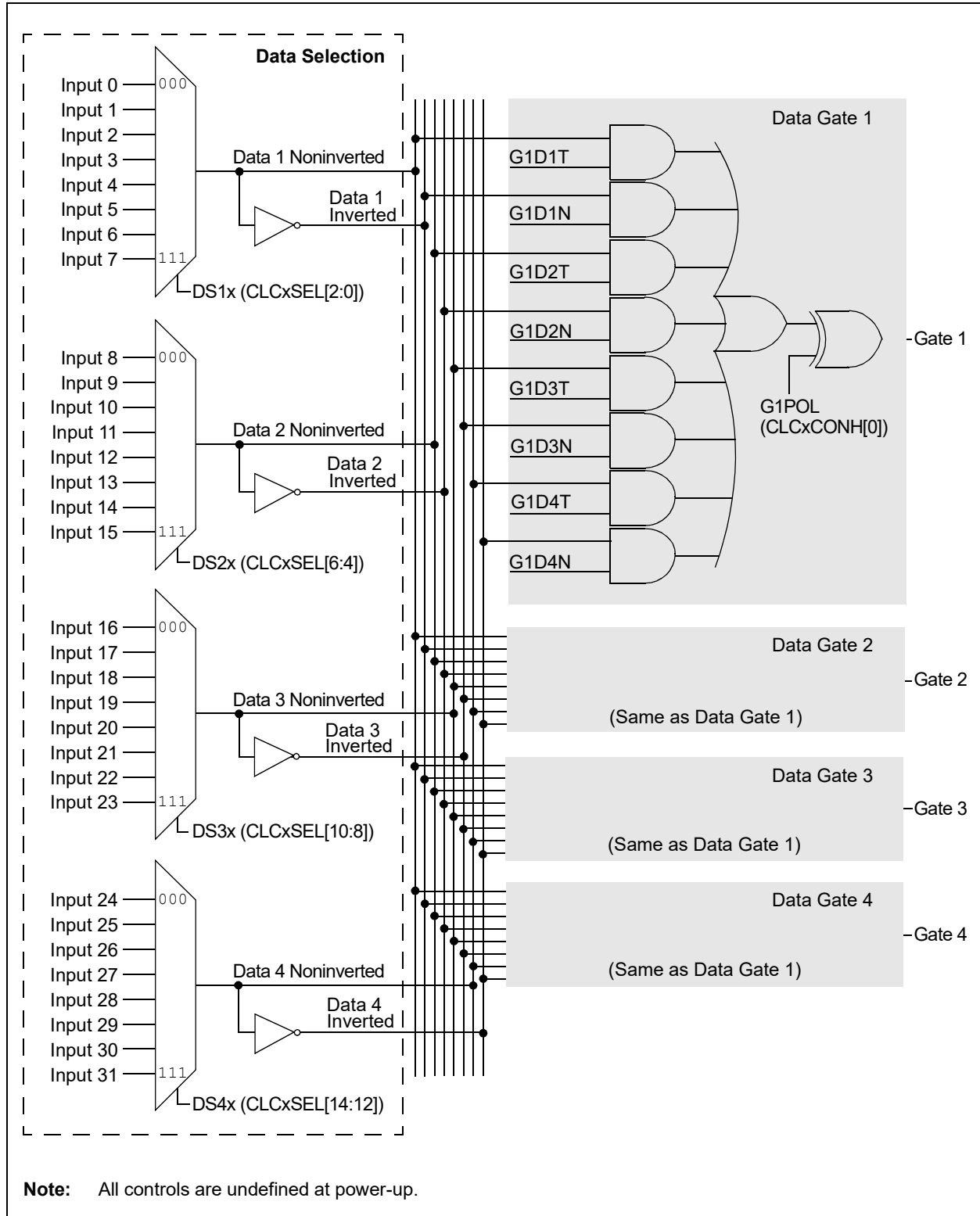
**FIGURE 23-2: CLCx LOGIC FUNCTION COMBINATORIAL OPTIONS**





# dsPIC33CK256MP508 FAMILY

**FIGURE 23-3: CLCx INPUT SOURCE SELECTION DIAGRAM**



# dsPIC33CK256MP508 FAMILY

## 23.1 CLC Control Registers

The CLCx module is controlled by the following registers:

- CLCxCONL
- CLCxCONH
- CLCxSEL
- CLCxGLSL
- CLCxGLSH

The CLCx Control registers (CLCxCONL and CLCxCONH) are used to enable the module and interrupts, control the output enable bit, select output polarity and select the logic function. The CLCx Control registers also allow the user to control the logic polarity of not only the cell output, but also some intermediate variables.

The CLCx Input MUX Select register (CLCxSEL) allows the user to select up to four data input sources using the four data input selection multiplexers. Each multiplexer has a list of eight data sources available.

The CLCx Gate Logic Input Select registers (CLCxGLSL and CLCxGLSH) allow the user to select which outputs from each of the selection MUXes are used as inputs to the input gates of the logic cell. Each data source MUX outputs both a true and a negated version of its output. All of these eight signals are enabled, ORed together by the logic cell input gates. If no gate inputs are selected, the input to the gate will be zero or one, depending on the GxPOL bits.

### REGISTER 23-1: CLCxCONL: CLCx CONTROL REGISTER (LOW)

R/W-0	U-0	U-0	U-0	R/W-0	R/W-0	U-0	U-0
LCEN	—	—	—	INTP	INTN	—	—
bit 15						bit 8	

R-0	R-0	R/W-0	U-0	U-0	R/W-0	R/W-0	R/W-0
LCOE	LCOUT	LCPOL	—	—	MODE2	MODE1	MODE0
bit 7						bit 0	

#### Legend:

R = Readable bit

W = Writable bit

U = Unimplemented bit, read as '0'

-n = Value at POR

'1' = Bit is set

'0' = Bit is cleared

x = Bit is unknown

bit 15      **LCEN:** CLCx Enable bit  
 1 = CLCx is enabled and mixing input signals  
 0 = CLCx is disabled and has logic zero outputs

bit 14-12    **Unimplemented:** Read as '0'

bit 11      **INTP:** CLCx Positive Edge Interrupt Enable bit  
 1 = Interrupt will be generated when a rising edge occurs on LCOUT  
 0 = Interrupt will not be generated

bit 10      **INTN:** CLCx Negative Edge Interrupt Enable bit  
 1 = Interrupt will be generated when a falling edge occurs on LCOUT  
 0 = Interrupt will not be generated

bit 9-8     **Unimplemented:** Read as '0'

bit 7        **LCOE:** CLCx Port Enable bit  
 1 = CLCx port pin output is enabled  
 0 = CLCx port pin output is disabled

bit 6        **LCOUT:** CLCx Data Output Status bit  
 1 = CLCx output high  
 0 = CLCx output low

bit 5        **LCPOL:** CLCx Output Polarity Control bit  
 1 = The output of the module is inverted  
 0 = The output of the module is not inverted

bit 4-3     **Unimplemented:** Read as '0'

# dsPIC33CK256MP508 FAMILY

## REGISTER 23-1: CLCxCONL: CLCx CONTROL REGISTER (LOW) (CONTINUED)

bit 2-0     **MODE[2:0]:** CLCx Mode bits  
 111 = Single input transparent latch with S and R  
 110 = JK flip-flop with R  
 101 = Two-input D flip-flop with R  
 100 = Single input D flip-flop with S and R  
 011 = SR latch  
 010 = Four-input AND  
 001 = Four-input OR-XOR  
 000 = Four-input AND-OR

## REGISTER 23-2: CLCxCONH: CLCx CONTROL REGISTER (HIGH)

U-0	U-0	U-0	U-0	U-0	U-0	U-0	U-0
—	—	—	—	—	—	—	—
bit 15							bit 8

U-0	U-0	U-0	U-0	R/W-0	R/W-0	R/W-0	R/W-0
—	—	—	—	G4POL	G3POL	G2POL	G1POL
bit 7							bit 0

### Legend:

R = Readable bit                      W = Writable bit                      U = Unimplemented bit, read as '0'  
 -n = Value at POR                      '1' = Bit is set                      '0' = Bit is cleared                      x = Bit is unknown

bit 15-4     **Unimplemented:** Read as '0'  
 bit 3        **G4POL:** Gate 4 Polarity Control bit  
             1 = Channel 4 logic output is inverted when applied to the logic cell  
             0 = Channel 4 logic output is not inverted  
 bit 2        **G3POL:** Gate 3 Polarity Control bit  
             1 = Channel 3 logic output is inverted when applied to the logic cell  
             0 = Channel 3 logic output is not inverted  
 bit 1        **G2POL:** Gate 2 Polarity Control bit  
             1 = Channel 2 logic output is inverted when applied to the logic cell  
             0 = Channel 2 logic output is not inverted  
 bit 0        **G1POL:** Gate 1 Polarity Control bit  
             1 = Channel 1 logic output is inverted when applied to the logic cell  
             0 = Channel 1 logic output is not inverted

# dsPIC33CK256MP508 FAMILY

## REGISTER 23-3: CLCxSEL: CLCx INPUT MUX SELECT REGISTER

U-0	R/W-0	R/W-0	R/W-0	U-0	R/W-0	R/W-0	R/W-0
—	DS4[2:0]			—	DS3[2:0]		
bit 15							bit 8

U-0	R/W-0	R/W-0	R/W-0	U-0	R/W-0	R/W-0	R/W-0
—	DS2[2:0]			—	DS1[2:0]		
bit 7							bit 0

### Legend:

R = Readable bit      W = Writable bit      U = Unimplemented bit, read as '0'  
 -n = Value at POR      '1' = Bit is set      '0' = Bit is cleared      x = Bit is unknown

- bit 15      **Unimplemented:** Read as '0'
- bit 14-12      **DS4[2:0]:** Data Selection MUX 4 Signal Selection bits  
 111 = SCCP3 auxiliary out  
 110 = SCCP1 auxiliary out  
 101 = CLCIND pin  
 100 = Reserved  
 011 = SPI1 Input (SDIx)<sup>(1)</sup>  
 010 = Comparator 3 output  
 001 = CLC2 output  
 000 = PWM Event A
- bit 11      **Unimplemented:** Read as '0'
- bit 10-8      **DS3[2:0]:** Data Selection MUX 3 Signal Selection bits  
 111 = SCCP4 output compare event  
 110 = SCCP3 output compare event  
 101 = CLC4 out  
 100 = UART1 RX  
 011 = SPI1 Output (SDOx)<sup>(1)</sup>  
 010 = Comparator 2 output  
 001 = CLC1 output  
 000 = CLCINC I/O pin
- bit 7      **Unimplemented:** Read as '0'
- bit 6-4      **DS2[2:0]:** Data Selection MUX 2 Signal Selection bits  
 111 = SCCP2 output compare event  
 110 = SCCP1 output compare event  
 101 = Reserved  
 100 = Reserved  
 011 = UART1 TX  
 010 = Comparator 1 output  
 001 = Reserved  
 000 = CLCINB I/O pin
- bit 3      **Unimplemented:** Read as '0'

**Note 1:** Valid only when SPI is used on PPS.

# dsPIC33CK256MP508 FAMILY

---

## REGISTER 23-3: CLCxSEL: CLCx INPUT MUX SELECT REGISTER (CONTINUED)

bit 2-0      **DS1[2:0]**: Data Selection MUX 1 Signal Selection bits

- 111 = SCCP4 auxiliary out
- 110 = SCCP2 auxiliary out
- 101 = Reserved
- 100 = REFCKO output
- 011 = INTRC/LPRC clock source
- 010 = CLC3 out
- 001 = System clock (FCY)
- 000 = CLCINA I/O pin

**Note 1:** Valid only when SPI is used on PPS.

# dsPIC33CK256MP508 FAMILY

## REGISTER 23-4: CLCxGLSL: CLCx GATE LOGIC INPUT SELECT LOW REGISTER

R/W-0	R/W-0	R/W-0	R/W-0	R/W-0	R/W-0	R/W-0	R/W-0
G2D4T	G2D4N	G2D3T	G2D3N	G2D2T	G2D2N	G2D1T	G2D1N
bit 15						bit 8	

R/W-0	R/W-0	R/W-0	R/W-0	R/W-0	R/W-0	R/W-0	R/W-0
G1D4T	G1D4N	G1D3T	G1D3N	G1D2T	G1D2N	G1D1T	G1D1N
bit 7						bit 0	

### Legend:

R = Readable bit

W = Writable bit

U = Unimplemented bit, read as '0'

-n = Value at POR

'1' = Bit is set

'0' = Bit is cleared

x = Bit is unknown

- bit 15      **G2D4T:** Gate 2 Data Source 4 True Enable bit  
 1 = Data Source 4 signal is enabled for Gate 2  
 0 = Data Source 4 signal is disabled for Gate 2
- bit 14      **G2D4N:** Gate 2 Data Source 4 Negated Enable bit  
 1 = Data Source 4 inverted signal is enabled for Gate 2  
 0 = Data Source 4 inverted signal is disabled for Gate 2
- bit 13      **G2D3T:** Gate 2 Data Source 3 True Enable bit  
 1 = Data Source 3 signal is enabled for Gate 2  
 0 = Data Source 3 signal is disabled for Gate 2
- bit 12      **G2D3N:** Gate 2 Data Source 3 Negated Enable bit  
 1 = Data Source 3 inverted signal is enabled for Gate 2  
 0 = Data Source 3 inverted signal is disabled for Gate 2
- bit 11      **G2D2T:** Gate 2 Data Source 2 True Enable bit  
 1 = Data Source 2 signal is enabled for Gate 2  
 0 = Data Source 2 signal is disabled for Gate 2
- bit 10      **G2D2N:** Gate 2 Data Source 2 Negated Enable bit  
 1 = Data Source 2 inverted signal is enabled for Gate 2  
 0 = Data Source 2 inverted signal is disabled for Gate 2
- bit 9        **G2D1T:** Gate 2 Data Source 1 True Enable bit  
 1 = Data Source 1 signal is enabled for Gate 2  
 0 = Data Source 1 signal is disabled for Gate 2
- bit 8        **G2D1N:** Gate 2 Data Source 1 Negated Enable bit  
 1 = Data Source 1 inverted signal is enabled for Gate 2  
 0 = Data Source 1 inverted signal is disabled for Gate 2
- bit 7        **G1D4T:** Gate 1 Data Source 4 True Enable bit  
 1 = Data Source 4 signal is enabled for Gate 1  
 0 = Data Source 4 signal is disabled for Gate 1
- bit 6        **G1D4N:** Gate 1 Data Source 4 Negated Enable bit  
 1 = Data Source 4 inverted signal is enabled for Gate 1  
 0 = Data Source 4 inverted signal is disabled for Gate 1
- bit 5        **G1D3T:** Gate 1 Data Source 3 True Enable bit  
 1 = Data Source 3 signal is enabled for Gate 1  
 0 = Data Source 3 signal is disabled for Gate 1
- bit 4        **G1D3N:** Gate 1 Data Source 3 Negated Enable bit  
 1 = Data Source 3 inverted signal is enabled for Gate 1  
 0 = Data Source 3 inverted signal is disabled for Gate 1

# dsPIC33CK256MP508 FAMILY

---

## REGISTER 23-4: CLCxGLSL: CLCx GATE LOGIC INPUT SELECT LOW REGISTER (CONTINUED)

- bit 3      **G1D2T:** Gate 1 Data Source 2 True Enable bit  
1 = Data Source 2 signal is enabled for Gate 1  
0 = Data Source 2 signal is disabled for Gate 1
- bit 2      **G1D2N:** Gate 1 Data Source 2 Negated Enable bit  
1 = Data Source 2 inverted signal is enabled for Gate 1  
0 = Data Source 2 inverted signal is disabled for Gate 1
- bit 1      **G1D1T:** Gate 1 Data Source 1 True Enable bit  
1 = Data Source 1 signal is enabled for Gate 1  
0 = Data Source 1 signal is disabled for Gate 1
- bit 0      **G1D1N:** Gate 1 Data Source 1 Negated Enable bit  
1 = Data Source 1 inverted signal is enabled for Gate 1  
0 = Data Source 1 inverted signal is disabled for Gate 1

# dsPIC33CK256MP508 FAMILY

## REGISTER 23-5: CLCxGLSH: CLCx GATE LOGIC INPUT SELECT HIGH REGISTER

R/W-0	R/W-0	R/W-0	R/W-0	R/W-0	R/W-0	R/W-0	R/W-0
G4D4T	G4D4N	G4D3T	G4D3N	G4D2T	G4D2N	G4D1T	G4D1N
bit 15						bit 8	

R/W-0	R/W-0	R/W-0	R/W-0	R/W-0	R/W-0	R/W-0	R/W-0
G3D4T	G3D4N	G3D3T	G3D3N	G3D2T	G3D2N	G3D1T	G3D1N
bit 7						bit 0	

### Legend:

R = Readable bit

W = Writable bit

U = Unimplemented bit, read as '0'

-n = Value at POR

'1' = Bit is set

'0' = Bit is cleared

x = Bit is unknown

- bit 15      **G4D4T:** Gate 4 Data Source 4 True Enable bit  
 1 = Data Source 4 signal is enabled for Gate 4  
 0 = Data Source 4 signal is disabled for Gate 4
- bit 14      **G4D4N:** Gate 4 Data Source 4 Negated Enable bit  
 1 = Data Source 4 inverted signal is enabled for Gate 4  
 0 = Data Source 4 inverted signal is disabled for Gate 4
- bit 13      **G4D3T:** Gate 4 Data Source 3 True Enable bit  
 1 = Data Source 3 signal is enabled for Gate 4  
 0 = Data Source 3 signal is disabled for Gate 4
- bit 12      **G4D3N:** Gate 4 Data Source 3 Negated Enable bit  
 1 = Data Source 3 inverted signal is enabled for Gate 4  
 0 = Data Source 3 inverted signal is disabled for Gate 4
- bit 11      **G4D2T:** Gate 4 Data Source 2 True Enable bit  
 1 = Data Source 2 signal is enabled for Gate 4  
 0 = Data Source 2 signal is disabled for Gate 4
- bit 10      **G4D2N:** Gate 4 Data Source 2 Negated Enable bit  
 1 = Data Source 2 inverted signal is enabled for Gate 4  
 0 = Data Source 2 inverted signal is disabled for Gate 4
- bit 9        **G4D1T:** Gate 4 Data Source 1 True Enable bit  
 1 = Data Source 1 signal is enabled for Gate 4  
 0 = Data Source 1 signal is disabled for Gate 4
- bit 8        **G4D1N:** Gate 4 Data Source 1 Negated Enable bit  
 1 = Data Source 1 inverted signal is enabled for Gate 4  
 0 = Data Source 1 inverted signal is disabled for Gate 4
- bit 7        **G3D4T:** Gate 3 Data Source 4 True Enable bit  
 1 = Data Source 4 signal is enabled for Gate 3  
 0 = Data Source 4 signal is disabled for Gate 3
- bit 6        **G3D4N:** Gate 3 Data Source 4 Negated Enable bit  
 1 = Data Source 4 inverted signal is enabled for Gate 3  
 0 = Data Source 4 inverted signal is disabled for Gate 3
- bit 5        **G3D3T:** Gate 3 Data Source 3 True Enable bit  
 1 = Data Source 3 signal is enabled for Gate 3  
 0 = Data Source 3 signal is disabled for Gate 3
- bit 4        **G3D3N:** Gate 3 Data Source 3 Negated Enable bit  
 1 = Data Source 3 inverted signal is enabled for Gate 3  
 0 = Data Source 3 inverted signal is disabled for Gate 3



# dsPIC33CK256MP508 FAMILY

---

---

## REGISTER 23-5: CLCxGLSH: CLCx GATE LOGIC INPUT SELECT HIGH REGISTER (CONTINUED)

- bit 3        **G3D2T:** Gate 3 Data Source 2 True Enable bit  
1 = Data Source 2 signal is enabled for Gate 3  
0 = Data Source 2 signal is disabled for Gate 3
- bit 2        **G3D2N:** Gate 3 Data Source 2 Negated Enable bit  
1 = Data Source 2 inverted signal is enabled for Gate 3  
0 = Data Source 2 inverted signal is disabled for Gate 3
- bit 1        **G3D1T:** Gate 3 Data Source 1 True Enable bit  
1 = Data Source 1 signal is enabled for Gate 3  
0 = Data Source 1 signal is disabled for Gate 3
- bit 0        **G3D1N:** Gate 3 Data Source 1 Negated Enable bit  
1 = Data Source 1 inverted signal is enabled for Gate 3  
0 = Data Source 1 inverted signal is disabled for Gate 3

# dsPIC33CK256MP508 FAMILY

---

---

NOTES:

## 24.0 PERIPHERAL TRIGGER GENERATOR (PTG)

**Note 1:** This data sheet summarizes the features of the dsPIC33CK256MP508 family of devices. It is not intended to be a comprehensive reference source. To complement the information in this data sheet, refer to “**Peripheral Trigger Generator (PTG)**” ([www.microchip.com/DS70000669](http://www.microchip.com/DS70000669)) in the “*dsPIC33/PIC24 Family Reference Manual*”.

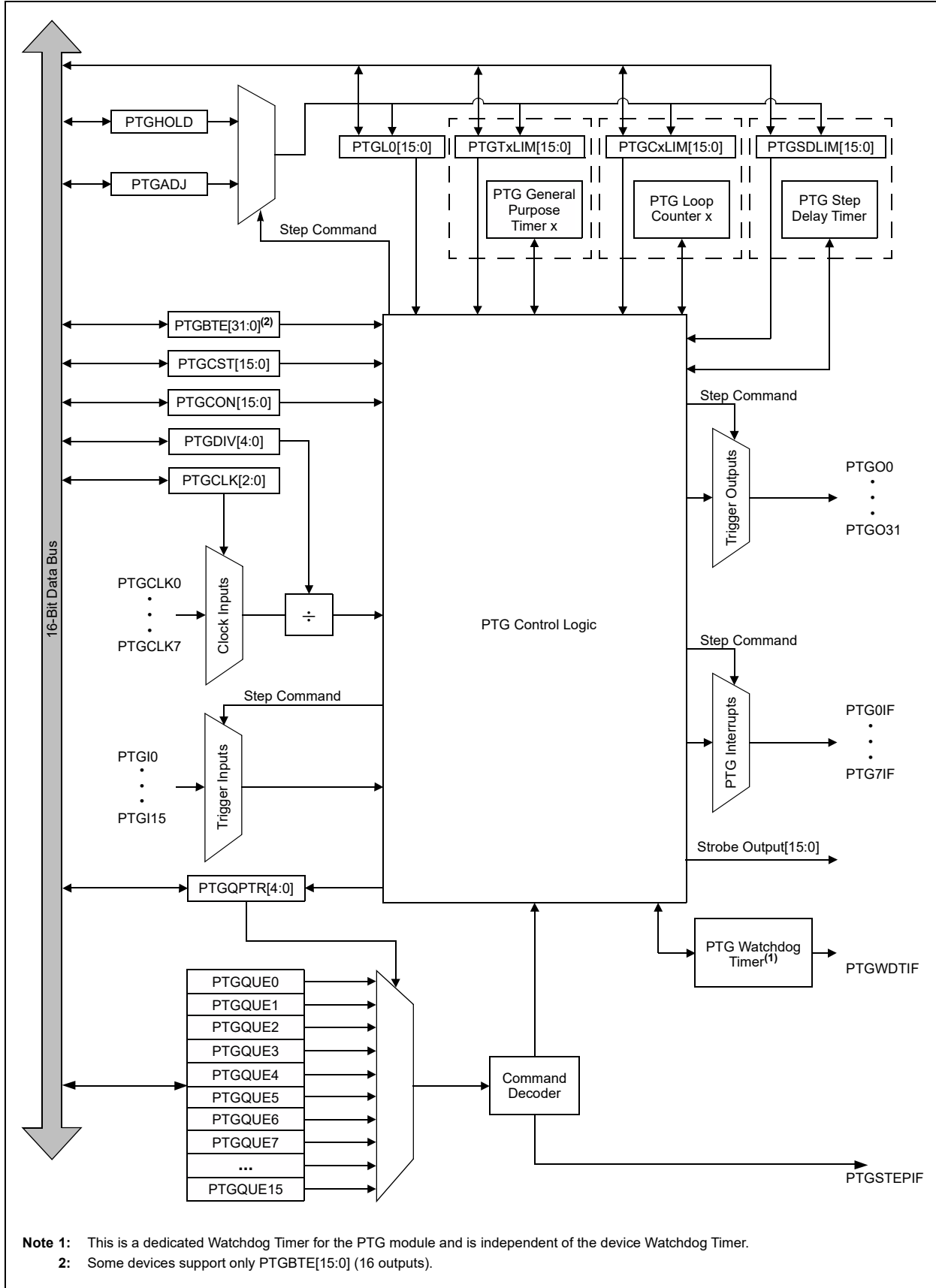
The dsPIC33CK256MP508 family Peripheral Trigger Generator (PTG) module is a user-programmable sequencer that is capable of generating complex trigger signal sequences to coordinate the operation of other peripherals. The PTG module is designed to interface with the modules, such as an Analog-to-Digital Converter (ADC), output compare and PWM modules, timers and interrupt controllers.

## 24.1 Features

- Behavior is Step Command Driven:
  - Step commands are eight bits wide
- Commands are Stored in a Step Queue:
  - Queue depth is up to 32 entries
  - Programmable Step execution time (Step delay)
- Supports the Command Sequence Loop:
  - Can be nested one-level deep
  - Conditional or unconditional loop
  - Two 16-bit loop counters
- 15 Hardware Input Triggers:
  - Sensitive to either positive or negative edges, or a high or low level
- One Software Input Trigger
- Generates up to 32 Unique Output Trigger Signals
- Generates Two Types of Trigger Outputs:
  - Individual
  - Broadcast
- Strobed Output Port for Literal Data Values:
  - 5-bit literal write (literal part of a command)
  - 16-bit literal write (literal held in the PTGL0 register)
- Generates up to Ten Unique Interrupt Signals
- Two 16-Bit General Purpose Timers
- Flexible Self-Contained Watchdog Timer (WDT) to Set an Upper Limit to Trigger Wait Time
- Single-Step Command Capability in Debug mode
- Selectable Clock (System, Pulse-Width Modulator (PWM) or ADC)
- Programmable Clock Divider

# dsPIC33CK256MP508 FAMILY

FIGURE 24-1: PTG BLOCK DIAGRAM



# dsPIC33CK256MP508 FAMILY

## 24.2 PTG Control Registers

### REGISTER 24-1: PTGCST: PTG CONTROL/STATUS LOW REGISTER

R/W-0	U-0	R/W-0	R/W-0	U-0	HC/R/W-0	R/W-0	R/W-0
PTGEN	—	PTGSIDL	PTGTOGL	—	PTGSWT <sup>(2)</sup>	PTGSSEN <sup>(3)</sup>	PTGIVIS
bit 15							bit 8

HC/R/W-0	HS/R/W-0	HS/HC/R/W-0	U-0	U-0	U-0	R/W-0	R/W-0
PTGSTRT	PTGWDTO	PTGBUSY	—	—	—	PTGITM1 <sup>(1)</sup>	PTGITM0 <sup>(1)</sup>
bit 7							bit 0

<b>Legend:</b>	HC = Hardware Clearable bit	HS = Hardware Settable bit
R = Readable bit	W = Writable bit	U = Unimplemented bit, read as '0'
-n = Value at POR	'1' = Bit is set	'0' = Bit is cleared
		x = Bit is unknown

- bit 15     **PTGEN:** PTG Enable bit  
1 = PTG is enabled  
0 = PTG is disabled
- bit 14     **Unimplemented:** Read as '0'
- bit 13     **PTGSIDL:** PTG Freeze in Debug Mode bit  
1 = Halts PTG operation when device is Idle  
0 = PTG operation continues when device is Idle
- bit 12     **PTGTOGL:** PTG Toggle Trigger Output bit  
1 = Toggles state of TRIG output for each execution of PTGTRIG  
0 = Generates a single TRIG pulse for each execution of PTGTRIG
- bit 11     **Unimplemented:** Read as '0'
- bit 10     **PTGSWT:** PTG Software Trigger bit<sup>(2)</sup>  
1 = If the PTG state machine is executing the "Wait for software trigger" Step command (OPTION[3:0] = 1010 or 1011), the command will complete and execution will continue  
0 = No action other than to clear the bit
- bit 9       **PTGSSEN:** PTG Single-Step Command bit<sup>(3)</sup>  
1 = Enables single Step when in Debug mode  
0 = Disables single Step
- bit 8       **PTGIVIS:** PTG Counter/Timer Visibility bit  
1 = Reading the PTGSDLIM, PTGCxLIM or PTGTxLIM registers returns the current values of their corresponding Counter/Timer registers (PTGSDLIM, PTGCxLIM and PTGTxLIM)  
0 = Reading the PTGSDLIM, PTGCxLIM or PTGTxLIM registers returns the value of these Limit registers
- bit 7       **PTGSTRT:** PTG Start Sequencer bit  
1 = Starts to sequentially execute the commands (Continuous mode)  
0 = Stops executing the commands
- bit 6       **PTGWDTO:** PTG Watchdog Timer Time-out Status bit  
1 = PTG Watchdog Timer has timed out  
0 = PTG Watchdog Timer has not timed out

- Note 1:** These bits apply to the PTGWHI and PTGWLO commands only.
- 2:** This bit is only used with the PTGCTRL Step command software trigger option.
- 3:** The PTGSSEN bit may only be written when in Debug mode.

# dsPIC33CK256MP508 FAMILY

---

## REGISTER 24-1: PTGCST: PTG CONTROL/STATUS LOW REGISTER (CONTINUED)

- bit 5      **PTGBUSY:** PTG State Machine Busy bit  
1 = PTG is running on the selected clock source; no SFR writes are allowed to PTGCLK[2:0] or PTGDIV[4:0]  
0 = PTG state machine is not running
- bit 4-2    **Unimplemented:** Read as '0'
- bit 1-0    **PTGITM[1:0]:** PTG Input Trigger Operation Selection bit<sup>(1)</sup>  
11 = Single-level detect with Step delay not executed on exit of command (regardless of the PTGCTRL command) (Mode 3)  
10 = Single-level detect with Step delay executed on exit of command (Mode 2)  
01 = Continuous edge detect with Step delay not executed on exit of command (regardless of the PTGCTRL command) (Mode 1)  
00 = Continuous edge detect with Step delay executed on exit of command (Mode 0)

- Note 1:** These bits apply to the PTGWHI and PTGWLO commands only.  
**2:** This bit is only used with the PTGCTRL Step command software trigger option.  
**3:** The PTGSSEN bit may only be written when in Debug mode.

# dsPIC33CK256MP508 FAMILY

## REGISTER 24-2: PTGCON: PTG CONTROL/STATUS HIGH REGISTER

R/W-0	R/W-0	R/W-0	R/W-0	R/W-0	R/W-0	R/W-0	R/W-0
PTGCLK2	PTGCLK1	PTGCLK0	PTGDIV4	PTGDIV3	PTGDIV2	PTGDIV1	PTGDIV0
bit 15							bit 8

R/W-0	R/W-0	R/W-0	R/W-0	U-0	R/W-0	R/W-0	R/W-0
PTGPWD3	PTGPWD2	PTGPWD1	PTGPWD0	—	PTGWDT2	PTGWDT1	PTGWDT0
bit 7							bit 0

### Legend:

R = Readable bit                      W = Writable bit                      U = Unimplemented bit, read as '0'  
 -n = Value at POR                      '1' = Bit is set                      '0' = Bit is cleared                      x = Bit is unknown

- bit 15-13      **PTGCLK[2:0]:** PTG Module Clock Source Selection bits
  - 111 = CLC1
  - 110 = PLL VCO DIV 4 output
  - 101 = PTG module clock source will be SCCP7
  - 100 = PTG module clock source will be SCCP8
  - 011 = Input from Timer1 Clock pin, T1CK
  - 010 = PTG module clock source will be ADC clock
  - 001 = PTG module clock source will be Fosc
  - 000 = PTG module clock source will be Fosc/2 (Fp)
  
- bit 12-8      **PTGDIV[4:0]:** PTG Module Clock Prescaler (Divider) bits
  - 11111 = Divide-by-32
  - 11110 = Divide-by-31
  - ...
  - 00001 = Divide-by-2
  - 00000 = Divide-by-1
  
- bit 7-4      **PTGPWD[3:0]:** PTG Trigger Output Pulse-Width (in PTG clock cycles) bits
  - 1111 = All trigger outputs are 16 PTG clock cycles wide
  - 1110 = All trigger outputs are 15 PTG clock cycles wide
  - ...
  - 0001 = All trigger outputs are 2 PTG clock cycles wide
  - 0000 = All trigger outputs are 1 PTG clock cycle wide
  
- bit 3      **Unimplemented:** Read as '0'
  
- bit 2-0      **PTGWDT[2:0]:** PTG Watchdog Timer Time-out Selection bits
  - 111 = Watchdog Timer will time out after 512 PTG clocks
  - 110 = Watchdog Timer will time out after 256 PTG clocks
  - 101 = Watchdog Timer will time out after 128 PTG clocks
  - 100 = Watchdog Timer will time out after 64 PTG clocks
  - 011 = Watchdog Timer will time out after 32 PTG clocks
  - 010 = Watchdog Timer will time out after 16 PTG clocks
  - 001 = Watchdog Timer will time out after 8 PTG clocks
  - 000 = Watchdog Timer is disabled

# dsPIC33CK256MP508 FAMILY

## REGISTER 24-3: PTGBTE: PTG BROADCAST TRIGGER ENABLE LOW REGISTER<sup>(1)</sup>

R/W-0	R/W-0	R/W-0	R/W-0	R/W-0	R/W-0	R/W-0	R/W-0
PTGBTE[15:8]							
bit 15							bit 8

R/W-0	R/W-0	R/W-0	R/W-0	R/W-0	R/W-0	R/W-0	R/W-0
PTGBTE[7:0]							
bit 7							bit 0

### Legend:

R = Readable bit                      W = Writable bit                      U = Unimplemented bit, read as '0'  
 -n = Value at POR                      '1' = Bit is set                      '0' = Bit is cleared                      x = Bit is unknown

bit 15-0            **PTGBTE[15:0]:** PTG Broadcast Trigger Enable bits  
                          1 = Generates trigger when the broadcast command is executed  
                          0 = Does not generate trigger when the broadcast command is executed

**Note 1:** These bits are read-only when the module is executing Step commands.

## REGISTER 24-4: PTGBTEH: PTG BROADCAST TRIGGER ENABLE HIGH REGISTER<sup>(1)</sup>

R/W-0	R/W-0	R/W-0	R/W-0	R/W-0	R/W-0	R/W-0	R/W-0
PTGBTE[31:24]							
bit 15							bit 8

R/W-0	R/W-0	R/W-0	R/W-0	R/W-0	R/W-0	R/W-0	R/W-0
PTGBTE[23:16]							
bit 7							bit 0

### Legend:

R = Readable bit                      W = Writable bit                      U = Unimplemented bit, read as '0'  
 -n = Value at POR                      '1' = Bit is set                      '0' = Bit is cleared                      x = Bit is unknown

bit 15-0            **PTGBTE[31:16]:** PTG Broadcast Trigger Enable bits  
                          1 = Generates trigger when the broadcast command is executed  
                          0 = Does not generate trigger when the broadcast command is executed

**Note 1:** These bits are read-only when the module is executing Step commands.



# dsPIC33CK256MP508 FAMILY

## REGISTER 24-5: PTGHOLD: PTG HOLD REGISTER<sup>(1)</sup>

R/W-0	R/W-0	R/W-0	R/W-0	R/W-0	R/W-0	R/W-0	R/W-0
PTGHOLD[15:8]							
bit 15				bit 8			

R/W-0	R/W-0	R/W-0	R/W-0	R/W-0	R/W-0	R/W-0	R/W-0
PTGHOLD[7:0]							
bit 7				bit 0			

### Legend:

R = Readable bit

W = Writable bit

U = Unimplemented bit, read as '0'

-n = Value at POR

'1' = Bit is set

'0' = Bit is cleared

x = Bit is unknown

bit 15-0 **PTGHOLD[15:0]:** PTG General Purpose Hold Register bits

This register holds the user-supplied data to be copied to the PTGTxLIM, PTGCxLIM, PTGSDLIM or PTGL0 register using the `PTGCOPY` command.

**Note 1:** These bits are read-only when the module is executing Step commands.

## REGISTER 24-6: PTGT0LIM: PTG TIMER0 LIMIT REGISTER<sup>(1)</sup>

R/W-0	R/W-0	R/W-0	R/W-0	R/W-0	R/W-0	R/W-0	R/W-0
PTGT0LIM[15:8]							
bit 15				bit 8			

R/W-0	R/W-0	R/W-0	R/W-0	R/W-0	R/W-0	R/W-0	R/W-0
PTGT0LIM[7:0]							
bit 7				bit 0			

### Legend:

R = Readable bit

W = Writable bit

U = Unimplemented bit, read as '0'

-n = Value at POR

'1' = Bit is set

'0' = Bit is cleared

x = Bit is unknown

bit 15-0 **PTGT0LIM[15:0]:** PTG Timer0 Limit Register bits

General Purpose Timer0 Limit register.

**Note 1:** These bits are read-only when the module is executing Step commands.

# dsPIC33CK256MP508 FAMILY

## REGISTER 24-7: PTGT1LIM: PTG TIMER1 LIMIT REGISTER<sup>(1)</sup>

R/W-0	R/W-0	R/W-0	R/W-0	R/W-0	R/W-0	R/W-0	R/W-0
PTGT1LIM[15:8]							
bit 15							bit 8

R/W-0	R/W-0	R/W-0	R/W-0	R/W-0	R/W-0	R/W-0	R/W-0
PTGT1LIM[7:0]							
bit 7							bit 0

### Legend:

R = Readable bit                      W = Writable bit                      U = Unimplemented bit, read as '0'  
-n = Value at POR                      '1' = Bit is set                      '0' = Bit is cleared                      x = Bit is unknown

bit 15-0            **PTGT1LIM[15:0]**: PTG Timer1 Limit Register bits  
General Purpose Timer1 Limit register.

**Note 1:** These bits are read-only when the module is executing Step commands.

## REGISTER 24-8: PTGSDLIM: PTG STEP DELAY LIMIT REGISTER<sup>(1)</sup>

R/W-0	R/W-0	R/W-0	R/W-0	R/W-0	R/W-0	R/W-0	R/W-0
PTGSDLIM[15:8]							
bit 15							bit 8

R/W-0	R/W-0	R/W-0	R/W-0	R/W-0	R/W-0	R/W-0	R/W-0
PTGSDLIM[7:0]							
bit 7							bit 0

### Legend:

R = Readable bit                      W = Writable bit                      U = Unimplemented bit, read as '0'  
-n = Value at POR                      '1' = Bit is set                      '0' = Bit is cleared                      x = Bit is unknown

bit 15-0            **PTGSDLIM[15:0]**: PTG Step Delay Limit Register bits  
This register holds a PTG Step delay value representing the number of additional PTG clocks between the start of a Step command and the completion of a Step command.

**Note 1:** These bits are read-only when the module is executing Step commands.

# dsPIC33CK256MP508 FAMILY

## REGISTER 24-9: PTGC0LIM: PTG COUNTER 0 LIMIT REGISTER<sup>(1)</sup>

R/W-0	R/W-0	R/W-0	R/W-0	R/W-0	R/W-0	R/W-0	R/W-0
PTGC0LIM[15:8]							
bit 15				bit 8			

R/W-0	R/W-0	R/W-0	R/W-0	R/W-0	R/W-0	R/W-0	R/W-0
PTGC0LIM[7:0]							
bit 7				bit 0			

### Legend:

R = Readable bit                      W = Writable bit                      U = Unimplemented bit, read as '0'  
-n = Value at POR                      '1' = Bit is set                      '0' = Bit is cleared                      x = Bit is unknown

bit 15-0      **PTGC0LIM[15:0]:** PTG Counter 0 Limit Register bits

This register is used to specify the loop count for the PTGJMPC0 Step command or as a Limit register for the General Purpose Counter 0.

**Note 1:** These bits are read-only when the module is executing Step commands.

## REGISTER 24-10: PTGC1LIM: PTG COUNTER 1 LIMIT REGISTER<sup>(1)</sup>

R/W-0	R/W-0	R/W-0	R/W-0	R/W-0	R/W-0	R/W-0	R/W-0
PTGC1LIM[15:8]							
bit 15				bit 8			

R/W-0	R/W-0	R/W-0	R/W-0	R/W-0	R/W-0	R/W-0	R/W-0
PTGC1LIM[7:0]							
bit 7				bit 0			

### Legend:

R = Readable bit                      W = Writable bit                      U = Unimplemented bit, read as '0'  
-n = Value at POR                      '1' = Bit is set                      '0' = Bit is cleared                      x = Bit is unknown

bit 15-0      **PTGC1LIM[15:0]:** PTG Counter 1 Limit Register bits

This register is used to specify the loop count for the PTGJMPC1 Step command or as a Limit register for the General Purpose Counter 1.

**Note 1:** These bits are read-only when the module is executing Step commands.

# dsPIC33CK256MP508 FAMILY

## REGISTER 24-11: PTGADJ: PTG ADJUST REGISTER<sup>(1)</sup>

R/W-0	R/W-0	R/W-0	R/W-0	R/W-0	R/W-0	R/W-0	R/W-0
PTGADJ[15:8]							
bit 15							bit 8

R/W-0	R/W-0	R/W-0	R/W-0	R/W-0	R/W-0	R/W-0	R/W-0
PTGADJ[7:0]							
bit 7							bit 0

### Legend:

R = Readable bit                      W = Writable bit                      U = Unimplemented bit, read as '0'  
-n = Value at POR                      '1' = Bit is set                      '0' = Bit is cleared                      x = Bit is unknown

bit 15-0                      **PTGADJ[15:0]:** PTG Adjust Register bits  
This register holds the user-supplied data to be added to the PTGTxLIM, PTGCxLIM, PTGSDLIM or PTGL0 register using the PTGADD command.

**Note 1:** These bits are read-only when the module is executing Step commands.

## REGISTER 24-12: PTGL0: PTG LITERAL 0 REGISTER<sup>(1,2)</sup>

R/W-0	R/W-0	R/W-0	R/W-0	R/W-0	R/W-0	R/W-0	R/W-0
PTGL0[15:8]							
bit 15							bit 8

R/W-0	R/W-0	R/W-0	R/W-0	R/W-0	R/W-0	R/W-0	R/W-0
PTGL0[7:0]							
bit 7							bit 0

### Legend:

R = Readable bit                      W = Writable bit                      U = Unimplemented bit, read as '0'  
-n = Value at POR                      '1' = Bit is set                      '0' = Bit is cleared                      x = Bit is unknown

bit 15-0                      **PTGL0[15:0]:** PTG Literal 0 Register bits  
This register holds the 6-bit value to be written to the CNVCHSEL[5:0] bits (ADCON3L[5:0]) with the PTGCTRL Step command.

**Note 1:** These bits are read-only when the module is executing Step commands.

**Note 2:** The PTG strobe output is typically connected to the ADC Channel Select register. This allows the PTG to directly control ADC channel switching. See the specific device data sheet for connections of the PTG output.

# dsPIC33CK256MP508 FAMILY

## REGISTER 24-13: PTGQPTR: PTG STEP QUEUE POINTER REGISTER<sup>(1)</sup>

U-0	U-0	U-0	U-0	U-0	U-0	U-0	U-0
—	—	—	—	—	—	—	—
bit 15							bit 8

U-0	U-0	U-0	R/W-0	R/W-0	R/W-0	R/W-0	R/W-0
—	—	—	PTGQPTR[4:0]				
bit 7							bit 0

### Legend:

R = Readable bit                      W = Writable bit                      U = Unimplemented bit, read as '0'  
 -n = Value at POR                      '1' = Bit is set                      '0' = Bit is cleared                      x = Bit is unknown

bit 15-5                      **Unimplemented:** Read as '0'

bit 4-0                      **PTGQPTR[4:0]:** PTG Step Queue Pointer Register bits  
 This register points to the currently active Step command in the Step queue.

**Note 1:** These bits are read-only when the module is executing Step commands.

## REGISTER 24-14: PTGQUE<sub>n</sub>: PTG STEP QUEUE <sub>n</sub> POINTER REGISTER (n = 0-15)<sup>(1)</sup>

R/W-0	R/W-0	R/W-0	R/W-0	R/W-0	R/W-0	R/W-0	R/W-0
STEP <sub>2n+1</sub> [7:0] <sup>(2)</sup>							
bit 15							bit 8

R/W-0	R/W-0	R/W-0	R/W-0	R/W-0	R/W-0	R/W-0	R/W-0
STEP <sub>2n</sub> [7:0] <sup>(2)</sup>							
bit 7							bit 0

### Legend:

R = Readable bit                      W = Writable bit                      U = Unimplemented bit, read as '0'  
 -n = Value at POR                      '1' = Bit is set                      '0' = Bit is cleared                      x = Bit is unknown

bit 15-8                      **STEP<sub>2n+1</sub>[7:0]:** PTG Command 2n+1 bits<sup>(2)</sup>  
 A queue location for storage of the STEP<sub>2n+1</sub> command byte, where 'n' is from PTGQUE<sub>n</sub>.

bit                      **STEP<sub>2n</sub>[7:0]:** PTG Command 2n bits<sup>(2)</sup>  
 A queue location for storage of the STEP<sub>2n</sub> command byte, where 'n' is the odd numbered Step Queue Pointers.

**Note 1:** These bits are read-only when the module is executing Step commands.

**2:** Refer to [Table 24-1](#) for the Step command encoding.

# dsPIC33CK256MP508 FAMILY

**TABLE 24-1: PTG STEP COMMAND FORMAT AND DESCRIPTION**

<b>Step Command Byte</b>			
		STEPx[7:0]	
CMD[3:0]		bit 4	bit 3
bit 7			bit 0
OPTION[3:0]			

bit 7-4	Step Command	CMD[3:0]	Command Description
	PTGCTRL	0000	Execute the control command as described by the OPTION[3:0] bits.
	PTGADD	0001	Add contents of the PTGADJ register to the target register as described by the OPTION[3:0] bits.
	PTGCOPY		Copy contents of the PTGHOLD register to the target register as described by the OPTION[3:0] bits.
	PTGSTRB	001x	Copy the values contained in the bits, CMD[0]:OPTION[3:0] to the strobe output bits [4:0].
	PTGWHI	0100	Wait for a low-to-high edge input from a selected PTG trigger input as described by the OPTION[3:0] bits.
	PTGWLO	0101	Wait for a high-to-low edge input from a selected PTG trigger input as described by the OPTION[3:0] bits.
	—	0110	Reserved; do not use. <sup>(1)</sup>
	PTGIRQ	0111	Generate individual interrupt request as described by the OPTION[3:0] bits.
	PTGTRIG	100x	Generate individual trigger output as described by the bits, CMD[0]:OPTION[3:0].
	PTGJMP	101x	Copy the values contained in the bits, CMD[0]:OPTION[3:0] to the PTGQPTR register, and jump to that Step queue.
	PTGJMPC0	110x	PTGC0 = PTGC0LIM: Increment the PTGQPTR register.
			PTGC0 ≠ PTGC0LIM: Increment Counter 0 (PTGC0) and copy the values contained in the bits, CMD[0]:OPTION[3:0] to the PTGQPTR register, and jump to that Step queue.
	PTGJMPC1	111x	PTGC1 = PTGC1LIM: Increment the PTGQPTR register.
			PTGC1 ≠ PTGC1LIM: Increment Counter 1 (PTGC1) and copy the values contained in the bits, CMD[0]:OPTION[3:0] to the PTGQPTR register, and jump to that Step queue.

**Note 1:** All reserved commands or options will execute, but they do not have any affect (i.e., execute as a NOP instruction).

# dsPIC33CK256MP508 FAMILY

**TABLE 24-2: PTG COMMAND OPTIONS**

bit 3-0	Step Command	OPTION[3:0]	Command Description
	PTGCTRL <sup>(1)</sup>	0000	NOP.
		0001	Reserved; do not use.
		0010	Disable Step delay timer (PTGSD).
		0011	Reserved; do not use.
		0100	Reserved; do not use.
		0101	Reserved; do not use.
		0110	Enable Step delay timer (PTGSD).
		0111	Reserved; do not use.
		1000	Start and wait for the PTG Timer0 to match the PTGT0LIM register.
		1001	Start and wait for the PTG Timer1 to match the PTGT1LIM register.
		1010	Wait for the software trigger (level, PTGSWT = 1).
		1011	Wait for the software trigger (positive edge, PTGSWT = 0 to 1).
		1100	Copy the PTGC0LIM register contents to the strobe output.
		1101	Copy the PTGC1LIM register contents to the strobe output.
		1110	Copy the PTGL0 register contents to the strobe output.
		1111	Generate the triggers indicated in the PTGBTE register.
	PTGADD <sup>(1)</sup>	0000	Add the PTGADJ register contents to the PTGC0LIM register.
		0001	Add the PTGADJ register contents to the PTGC1LIM register.
		0010	Add the PTGADJ register contents to the PTGT0LIM register.
		0011	Add the PTGADJ register contents to the PTGT1LIM register.
		0100	Add the PTGADJ register contents to the PTGSDLIM register.
		0101	Add the PTGADJ register contents to the PTGL0 register.
		0110	Reserved; do not use.
		0111	Reserved; do not use.
	PTGCOPY <sup>(1)</sup>	1000	Copy the PTGHOLD register contents to the PTGC0LIM register.
		1001	Copy the PTGHOLD register contents to the PTGC1LIM register.
		1010	Copy the PTGHOLD register contents to the PTGT0LIM register.
		1011	Copy the PTGHOLD register contents to the PTGT1LIM register.
		1100	Copy the PTGHOLD register contents to the PTGSDLIM register.
		1101	Copy the PTGHOLD register contents to the PTGL0 register.
		1110	Reserved; do not use.
		1111	Reserved; do not use.

**Note 1:** All reserved commands or options will execute, but they do not have any affect (i.e., execute as a NOP instruction).

# dsPIC33CK256MP508 FAMILY

**TABLE 24-2: PTG COMMAND OPTIONS (CONTINUED)**

bit 3-0	Step Command	OPTION[3:0]	Option Description	
	PTGWHI <sup>(1)</sup> or PTGWLO <sup>(1)</sup>	0000	PTGI0 (see <a href="#">Table 24-3</a> for input assignments).	
		.	.	
		.	.	
		.	.	
			1111	PTGI15 (see <a href="#">Table 24-3</a> for input assignments).
	PTGIRQ <sup>(1)</sup>		0000	Generate PTG Interrupt 0.
			.	.
			.	.
			.	.
			0111	Generate PTG Interrupt 7.
			1000	Reserved; do not use.
			.	.
		.	.	
		.	.	
		1111	Reserved; do not use.	
	PTGTRIG		00000	PTGO0 (see <a href="#">Table 24-4</a> for output assignments).
			00001	PTGO1 (see <a href="#">Table 24-4</a> for output assignments).
			.	.
			.	.
			.	.
		11110	PTGO30 (see <a href="#">Table 24-4</a> for output assignments).	
		11111	PTGO31 (see <a href="#">Table 24-4</a> for output assignments).	
	PTGWHI <sup>(1)</sup> or PTGWLO <sup>(1)</sup>		0000	PTGI0 (see specific device data sheet for input assignments).
			.	.
			.	.
			1111	PTGI15 (see specific device data sheet for input assignments).
	PTGIRQ <sup>(1)</sup>		0000	Generate PTG Interrupt 0 (see specific device data sheet for interrupt assignments).
			.	.
		.	.	
		.	.	
		0111	Generate PTG Interrupt 7 (see specific device data sheet for interrupt assignments).	
		1000	Reserved; do not use.	
		.	.	
	.	.		
	.	.		
	1111	Reserved; do not use.		
PTGTRIG		00000	PTGO0 (see specific device data sheet for assignments).	
		00001	PTGO1 (see specific device data sheet for assignments).	

**Note 1:** All reserved commands or options will execute, but they do not have any affect (i.e., execute as a NOP instruction).



# dsPIC33CK256MP508 FAMILY

**TABLE 24-3: PTG INPUT DESCRIPTIONS**

PTG Input Number	PTG Input Description
PTG Trigger Input 0	Trigger Input from PWM1 ADC Trigger 2
PTG Trigger Input 1	Trigger Input from PWM2 ADC Trigger 2
PTG Trigger Input 2	Trigger Input from PWM3 ADC Trigger 2
PTG Trigger Input 3	Trigger Input from PWM4 ADC Trigger 2
PTG Trigger Input 4	Trigger Input from PWM5 ADC Trigger 2
PTG Trigger Input 5	Trigger Input from PWM6 ADC Trigger 2
PTG Trigger Input 6	Trigger Input from PWM7 ADC Trigger 2
PTG Trigger Input 7	Trigger Input from SCCP4
PTG Trigger Input 8	Trigger Input from SCCP5
PTG Trigger Input 9	Trigger Input from Comparator 1
PTG Trigger Input 10	Trigger Input from Comparator 2
PTG Trigger Input 11	Trigger Input from Comparator 3
PTG Trigger Input 12	Trigger Input from CLC1
PTG Trigger Input 13	Trigger Input from ADC Done Group Interrupt
PTG Trigger Input 14	Reserved
PTG Trigger Input 15	Trigger Input from INT2 PPS

**TABLE 24-4: PTG OUTPUT DESCRIPTIONS**

PTG Output Number	PTG Output Description
PTGO0 to PTGO11	Reserved
PTGO12	ADC TRGSRC[30]
PTGO13 to PTGO23	Reserved
PTGO24	PPS Output RP46
PTGO25	PPS Output RP47
PTGO26	PPS Input RP6
PTGO27	PPS Input RP7
PTGO28 to PTGO31	Reserved

# dsPIC33CK256MP508 FAMILY

---

NOTES:

## 25.0 32-BIT PROGRAMMABLE CYCLIC REDUNDANCY CHECK (CRC) GENERATOR

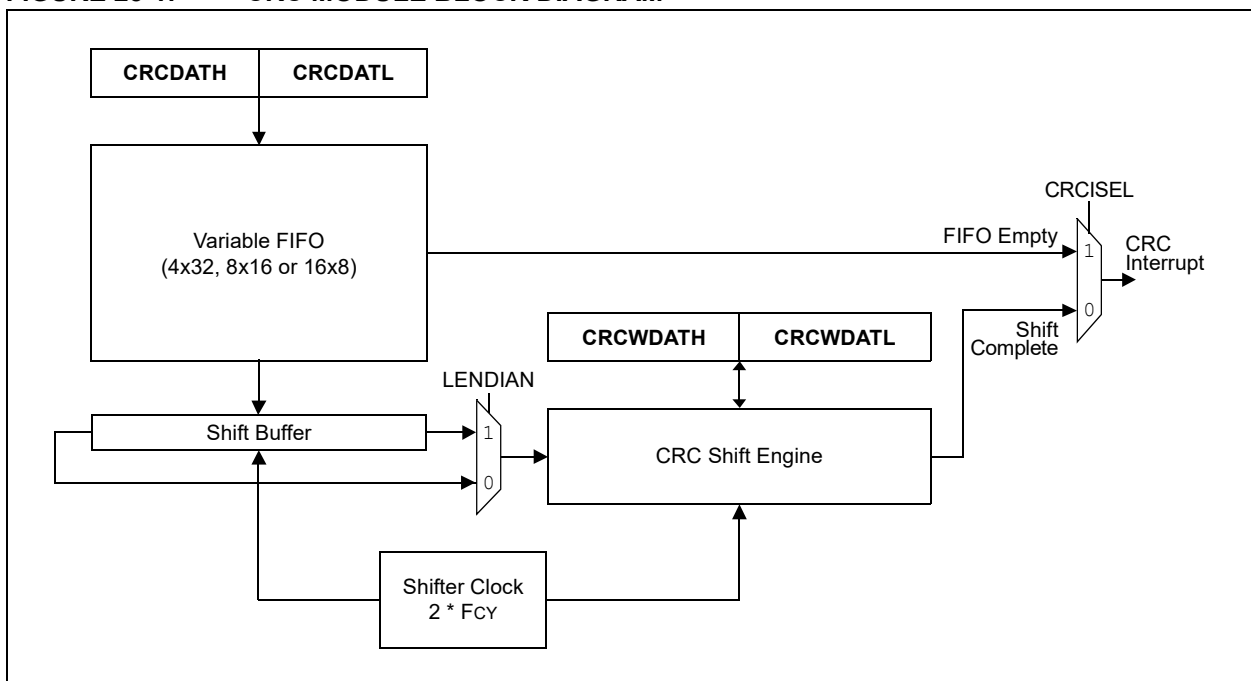
**Note 1:** This data sheet summarizes the features of the dsPIC33CK256MP508 family of devices. It is not intended to be a comprehensive reference source. For more information, refer to “32-Bit Programmable Cyclic Redundancy Check (CRC)” ([www.microchip.com/DS30009729](http://www.microchip.com/DS30009729)) in the “dsPIC33/PIC24 Family Reference Manual”.

The 32-bit programmable CRC generator provides a hardware implemented method of quickly generating checksums for various networking and security applications. It offers the following features:

- User-Programmable CRC Polynomial Equation, up to 32 Bits
- Programmable Shift Direction (little or big-endian)
- Independent Data and Polynomial Lengths
- Configurable Interrupt Output
- Data FIFO

A simple version of the CRC shift engine is displayed in [Figure 25-1](#).

**FIGURE 25-1: CRC MODULE BLOCK DIAGRAM**



# dsPIC33CK256MP508 FAMILY

## 25.1 CRC Control Registers

### REGISTER 25-1: CRCCONL: CRC CONTROL REGISTER LOW

R/W-0	U-0	R/W-0	HSC/R-0	HSC/R-0	HSC/R-0	HSC/R-0	HSC/R-0
CRCEN	—	CSIDL	VWORD4	VWORD3	VWORD2	VWORD1	VWORD0
bit 15							bit 8

HSC/R-0	HSC/R-1	R/W-0	HC/R/W-0	R/W-0	R/W-0	U-0	U-0
CRCFUL	CRCMPT	CRCISEL	CRCGO	LENDIAN	MOD	—	—
bit 7							bit 0

<b>Legend:</b>	HC = Hardware Clearable bit	HSC = Hardware Settable/Clearable bit
R = Readable bit	W = Writable bit	U = Unimplemented bit, read as '0'
-n = Value at POR	'1' = Bit is set	'0' = Bit is cleared
		x = Bit is unknown

- bit 15     **CRCEN:** CRC Enable bit  
1 = Enables module  
0 = Disables module
- bit 14     **Unimplemented:** Read as '0'
- bit 13     **CSIDL:** CRC Stop in Idle Mode bit  
1 = Discontinues module operation when device enters Idle mode  
0 = Continues module operation in Idle mode
- bit 12-8   **VWORD[4:0]:** Pointer Value bits  
Indicates the number of valid words in the FIFO. Has a maximum value of 8 when PLEN[4:0] ≥ 7 or 16 when PLEN[4:0] ≤ 7.
- bit 7     **CRCFUL:** CRC FIFO Full bit  
1 = FIFO is full  
0 = FIFO is not full
- bit 6     **CRCMPT:** CRC FIFO Empty bit  
1 = FIFO is empty  
0 = FIFO is not empty
- bit 5     **CRCISEL:** CRC Interrupt Selection bit  
1 = Interrupt on FIFO is empty; the final word of data is still shifting through the CRC  
0 = Interrupt on shift is complete and results are ready
- bit 4     **CRCGO:** CRC Start bit  
1 = Starts CRC serial shifter  
0 = CRC serial shifter is turned off
- bit 3     **LENDIAN:** Data Shift Direction Select bit  
1 = Data word is shifted into the FIFO, starting with the LSb (little-endian)  
0 = Data word is shifted into the FIFO, starting with the MSb (big-endian)
- bit 2     **MOD:** CRC Calculation Mode bit  
1 = Alternate mode  
0 = Legacy mode bit
- bit 1-0   **Unimplemented:** Read as '0'

# dsPIC33CK256MP508 FAMILY

## REGISTER 25-2: CRCCONH: CRC CONTROL REGISTER HIGH

U-0	U-0	U-0	R/W-0	R/W-0	R/W-0	R/W-0	R/W-0
—	—	—	DWIDTH[4:0]				
bit 15							bit 8

U-0	U-0	U-0	R/W-0	R/W-0	R/W-0	R/W-0	R/W-0
—	—	—	PLEN[4:0]				
bit 7							bit 0

### Legend:

R = Readable bit

W = Writable bit

U = Unimplemented bit, read as '0'

-n = Value at POR

'1' = Bit is set

'0' = Bit is cleared

x = Bit is unknown

bit 15-13 **Unimplemented:** Read as '0'

bit 12-8 **DWIDTH[4:0]:** Data Word Width Configuration bits  
Configures the width of the data word (Data Word Width – 1).

bit 7-5 **Unimplemented:** Read as '0'

bit 4-0 **PLEN[4:0]:** Polynomial Length Configuration bits  
Configures the length of the polynomial (Polynomial Length – 1).

# dsPIC33CK256MP508 FAMILY

## REGISTER 25-3: CRCXORL: CRC XOR POLYNOMIAL REGISTER, LOW

R/W-0	R/W-0	R/W-0	R/W-0	R/W-0	R/W-0	R/W-0	R/W-0
X[15:8]							
bit 15							bit 8

R/W-0	R/W-0	R/W-0	R/W-0	R/W-0	R/W-0	R/W-0	U-0
X[7:1]							—
bit 7							bit 0

**Legend:**

R = Readable bit                      W = Writable bit                      U = Unimplemented bit, read as '0'  
 -n = Value at POR                      '1' = Bit is set                      '0' = Bit is cleared                      x = Bit is unknown

bit 15-1        **X[15:1]:** XOR of Polynomial Term  $x^n$  Enable bits  
 bit 0            **Unimplemented:** Read as '0'

## REGISTER 25-4: CRCXORH: CRC XOR POLYNOMIAL REGISTER, HIGH

R/W-0	R/W-0	R/W-0	R/W-0	R/W-0	R/W-0	R/W-0	R/W-0
X[31:24]							
bit 15							bit 8

R/W-0	R/W-0	R/W-0	R/W-0	R/W-0	R/W-0	R/W-0	R/W-0
X[23:16]							
bit 7							bit 0

**Legend:**

R = Readable bit                      W = Writable bit                      U = Unimplemented bit, read as '0'  
 -n = Value at POR                      '1' = Bit is set                      '0' = Bit is cleared                      x = Bit is unknown

bit 15-0        **X[31:16]:** XOR of Polynomial Term  $x^n$  Enable bits

# dsPIC33CK256MP508 FAMILY

## 26.0 CURRENT BIAS GENERATOR (CBG)

**Note 1:** This data sheet summarizes the features of the dsPIC33CK256MP508 family of devices. It is not intended to be a comprehensive reference source. To complement the information in this data sheet, refer to “**Current Bias Generator (CBG)**” ([www.microchip.com/DS70005253](http://www.microchip.com/DS70005253)) in the “dsPIC33/PIC24 Family Reference Manual”.

**2:** Some registers and associated bits described in this section may not be available on all devices. Refer to [Table 26-1](#) for CBG channel availability on package variants.

The Current Bias Generator (CBG) consists of two classes of current sources: 10  $\mu\text{A}$  and 50  $\mu\text{A}$  sources. The major features of each current source are:

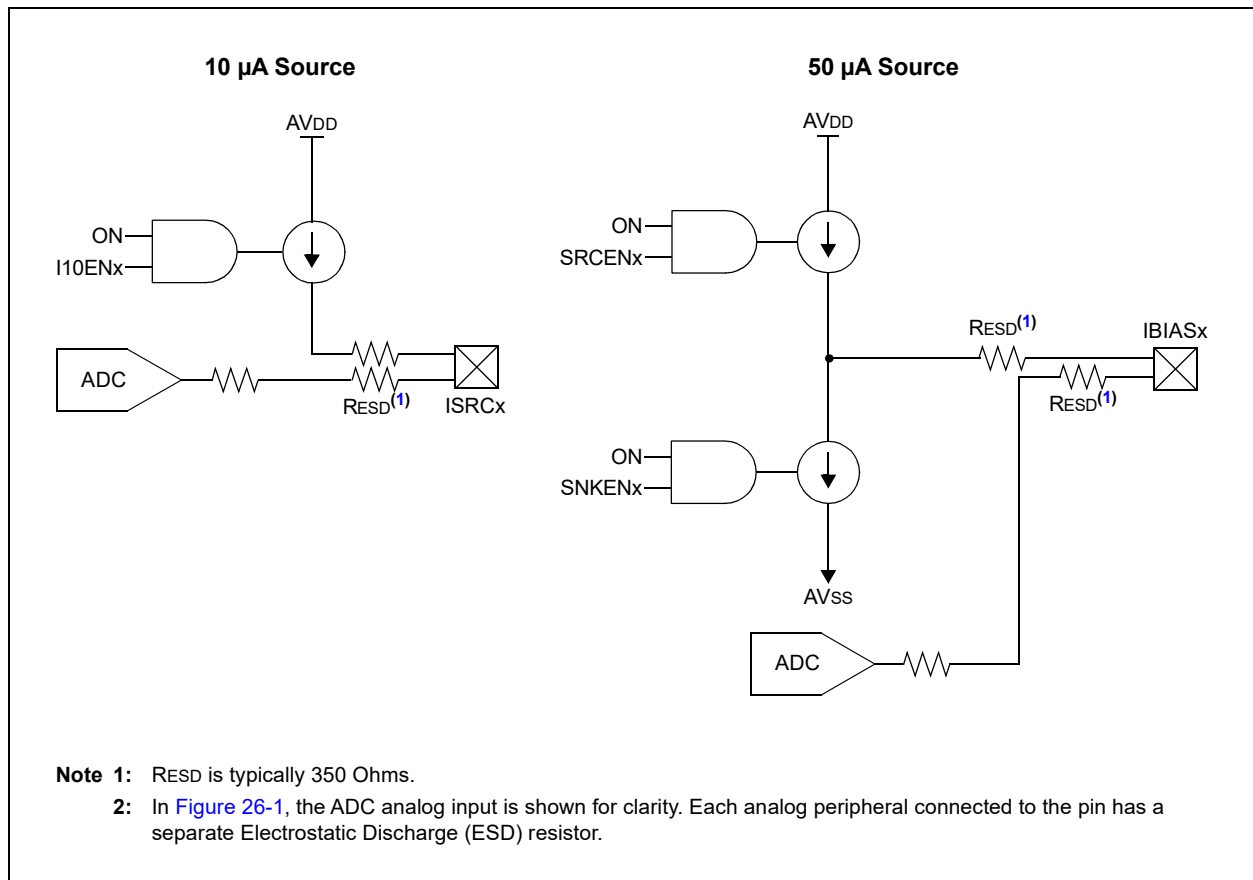
- 10  $\mu\text{A}$  Current Sources:
  - Current sourcing only
  - Up to four independent sources
- 50  $\mu\text{A}$  Current Sources:
  - Selectable current sourcing or sinking
  - Selectable current mirroring for sourcing and sinking

A simplified block diagram of the CBG module is shown in [Figure 26-1](#).

**TABLE 26-1: CBG CHANNEL AVAILABILITY**

Package Type	ISRCx	IBIASx
28-pin	—	0,3
36-pin	0,1	0,2,3
48-pin	0,1,2,3	0,1,2,3
64-pin	0,1,2,3	0,1,2,3
80-pin	0,1,2,3	0,1,2,3

**FIGURE 26-1: CONSTANT-CURRENT SOURCE MODULE BLOCK DIAGRAM<sup>(2)</sup>**



# dsPIC33CK256MP508 FAMILY

## 26.1 Current Bias Generator Control Registers

**REGISTER 26-1: BIASCON: CURRENT BIAS GENERATOR CONTROL REGISTER**

R/W-0	U-0	U-0	U-0	U-0	U-0	U-0	U-0
ON	—	—	—	—	—	—	—
bit 15							bit 8

U-0	U-0	U-0	U-0	R/W-0	R/W-0	R/W-0	R/W-0
—	—	—	—	I10EN3	I10EN2	I10EN1	I10EN0
bit 7							bit 0

**Legend:**

R = Readable bit                      W = Writable bit                      U = Unimplemented bit, read as '0'  
 -n = Value at POR                      '1' = Bit is set                      '0' = Bit is cleared                      x = Bit is unknown

- bit 15            **ON:** Current Bias Module Enable bit  
                   1 = Module is enabled  
                   0 = Module is disabled
- bit 14-4        **Unimplemented:** Read as '0'
- bit 3            **I10EN3:** 10  $\mu$ A Enable for Output 3 bit  
                   1 = 10  $\mu$ A output is enabled  
                   0 = 10  $\mu$ A output is disabled
- bit 2            **I10EN2:** 10  $\mu$ A Enable for Output 2 bit  
                   1 = 10  $\mu$ A output is enabled  
                   0 = 10  $\mu$ A output is disabled
- bit 1            **I10EN1:** 10  $\mu$ A Enable for Output 1 bit  
                   1 = 10  $\mu$ A output is enabled  
                   0 = 10  $\mu$ A output is disabled
- bit 0            **I10EN0:** 10  $\mu$ A Enable for Output 0 bit  
                   1 = 10  $\mu$ A output is enabled  
                   0 = 10  $\mu$ A output is disabled



# dsPIC33CK256MP508 FAMILY

## REGISTER 26-2: IBIASCONH: CURRENT BIAS GENERATOR 50 $\mu$ A CURRENT SOURCE CONTROL HIGH REGISTER

U-0	U-0	R/W-0	R/W-0	R/W-0	R/W-0	R/W-0	R/W-0
—	—	SHRSRCEN3	SHRSNKEN3	GENSRCEN3	GENSNKEN3	SRCEN3	SNKEN3
bit 15						bit 8	

U-0	U-0	R/W-0	R/W-0	R/W-0	R/W-0	R/W-0	R/W-0
—	—	SHRSRCEN2	SHRSNKEN2	GENSRCEN2	GENSNKEN2	SRCEN2	SNKEN2
bit 7						bit 0	

### Legend:

R = Readable bit	W = Writable bit	U = Unimplemented bit, read as '0'
-n = Value at POR	'1' = Bit is set	'0' = Bit is cleared
		x = Bit is unknown

- bit 15-14    **Unimplemented:** Read as '0'
- bit 13      **SHRSRCEN3:** Share Source Enable for Output #3 bit  
1 = Sourcing Current Mirror mode is enabled (uses reference from another source)  
0 = Sourcing Current Mirror mode is disabled
- bit 12      **SHRSNKEN3:** Share Sink Enable for Output #3 bit  
1 = Sinking Current Mirror mode is enabled (uses reference from another source)  
0 = Sinking Current Mirror mode is disabled
- bit 11      **GENSRCEN3:** Generated Source Enable for Output #3 bit  
1 = Source generates the current source mirror reference  
0 = Source does not generate the current source mirror reference
- bit 10      **GENSNKEN3:** Generated Sink Enable for Output #3 bit  
1 = Source generates the current sink mirror reference  
0 = Source does not generate the current sink mirror reference
- bit 9        **SRCEN3:** Source Enable for Output #3 bit  
1 = Current source is enabled  
0 = Current source is disabled
- bit 8        **SNKEN3:** Sink Enable for Output #3 bit  
1 = Current sink is enabled  
0 = Current sink is disabled
- bit 7-6     **Unimplemented:** Read as '0'
- bit 5        **SHRSRCEN2:** Share Source Enable for Output #2 bit  
1 = Sourcing Current Mirror mode is enabled (uses reference from another source)  
0 = Sourcing Current Mirror mode is disabled
- bit 4        **SHRSNKEN2:** Share Sink Enable for Output #2 bit  
1 = Sinking Current Mirror mode is enabled (uses reference from another source)  
0 = Sinking Current Mirror mode is disabled
- bit 3        **GENSRCEN2:** Generated Source Enable for Output #2 bit  
1 = Source generates the current source mirror reference  
0 = Source does not generate the current source mirror reference
- bit 2        **GENSNKEN2:** Generated Sink Enable for Output #2 bit  
1 = Source generates the current sink mirror reference  
0 = Source does not generate the current sink mirror reference
- bit 1        **SRCEN2:** Source Enable for Output #2 bit  
1 = Current source is enabled  
0 = Current source is disabled
- bit 0        **SNKEN2:** Sink Enable for Output #2 bit  
1 = Current sink is enabled  
0 = Current sink is disabled

# dsPIC33CK256MP508 FAMILY

## REGISTER 26-3: IBIASCONL: CURRENT BIAS GENERATOR 50 $\mu$ A CURRENT SOURCE CONTROL LOW REGISTER

U-0	U-0	R/W-0	R/W-0	R/W-0	R/W-0	R/W-0	R/W-0
—	—	SHRSRCEN1	SHRSNKEN1	GENSRCEN1	GENSNKEN1	SRCEN1	SNKEN1
bit 15							bit 8

U-0	U-0	R/W-0	R/W-0	R/W-0	R/W-0	R/W-0	R/W-0
—	—	SHRSRCEN0	SHRSNKEN0	GENSRCEN0	GENSNKEN0	SRCEN0	SNKEN0
bit 7							bit 0

<b>Legend:</b>							
R = Readable bit	W = Writable bit	U = Unimplemented bit, read as '0'					
-n = Value at POR	'1' = Bit is set	'0' = Bit is cleared	x = Bit is unknown				

- bit 15-14     **Unimplemented:** Read as '0'
- bit 13       **SHRSRCEN1:** Share Source Enable for Output #1 bit  
1 = Sourcing Current Mirror mode is enabled (uses reference from another source)  
0 = Sourcing Current Mirror mode is disabled
- bit 12       **SHRSNKEN1:** Share Sink Enable for Output #1 bit  
1 = Sinking Current Mirror mode is enabled (uses reference from another source)  
0 = Sinking Current Mirror mode is disabled
- bit 11       **GENSRCEN1:** Generated Source Enable for Output #1 bit  
1 = Source generates the current source mirror reference  
0 = Source does not generate the current source mirror reference
- bit 10       **GENSNKEN1:** Generated Sink Enable for Output #1 bit  
1 = Source generates the current sink mirror reference  
0 = Source does not generate the current sink mirror reference
- bit 9         **SRCEN1:** Source Enable for Output #1 bit  
1 = Current source is enabled  
0 = Current source is disabled
- bit 8         **SNKEN1:** Sink Enable for Output #1 bit  
1 = Current sink is enabled  
0 = Current sink is disabled
- bit 7-6       **Unimplemented:** Read as '0'
- bit 5         **SHRSRCEN0:** Share Source Enable for Output #0 bit  
1 = Sourcing Current Mirror mode is enabled (uses reference from another source)  
0 = Sourcing Current Mirror mode is disabled
- bit 4         **SHRSNKEN0:** Share Sink Enable for Output #0 bit  
1 = Sinking Current Mirror mode is enabled (uses reference from another source)  
0 = Sinking Current Mirror mode is disabled
- bit 3         **GENSRCEN0:** Generated Source Enable for Output #0 bit  
1 = Source generates the current source mirror reference  
0 = Source does not generate the current source mirror reference
- bit 2         **GENSNKEN0:** Generated Sink Enable for Output #0 bit  
1 = Source generates the current sink mirror reference  
0 = Source does not generate the current sink mirror reference
- bit 1         **SRCEN0:** Source Enable for Output #0 bit  
1 = Current source is enabled  
0 = Current source is disabled
- bit 0         **SNKEN0:** Sink Enable for Output #0 bit  
1 = Current sink is enabled  
0 = Current sink is disabled

## 27.0 OPERATIONAL AMPLIFIER

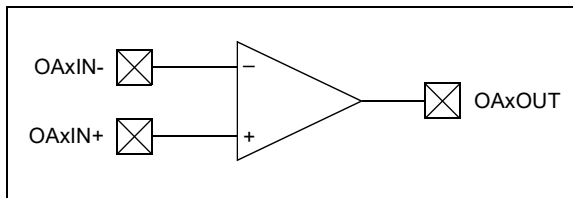
**Note:** Some device variants support only two op amp instances. Refer to [Table 1](#) and [Table 2](#) for availability.

The dsPIC33CK256MP508 family implements three instances of operational amplifiers (op amps). The op amps can be used for a wide variety of purposes, including signal conditioning and filtering. The three op amps are functionally identical. The block diagram for a single amplifier is shown in [Figure 27-1](#).

The op amps are controlled by two SFR registers: AMPCON1L and AMPCON1H. They remain in a low-power state until the AMPON bit is set. Each op amp can then be enabled independently by setting the corresponding AMPENx bit (x = 1, 2, 3).

The NCHDISx bit provides some flexibility regarding input range versus Integral Nonlinearity (INL). When NCHDISx = 0 (default), the op amps have a wider input voltage range (see [Table 33-44](#) in [Section 33.0 “Electrical Characteristics”](#)). When NCHDISx = 1, the wider input range is traded for improved INL performance (lower INL).

**FIGURE 27-1: SINGLE OPERATIONAL AMPLIFIER BLOCK DIAGRAM**



# dsPIC33CK256MP508 FAMILY

## 27.1 Operational Amplifier Control Registers

### REGISTER 27-1: AMPCON1L: OP AMP CONTROL REGISTER LOW

R/W-0	U-0	U-0	U-0	U-0	U-0	U-0	U-0
AMPON	—	—	—	—	—	—	—
bit 15							bit 8

U-0	U-0	U-0	U-0	U-0	R/W-0	R/W-0	R/W-0
—	—	—	—	—	AMPEN3	AMPEN2	AMPEN1
bit 7							bit 0

**Legend:**

R = Readable bit	W = Writable bit	U = Unimplemented bit, read as '0'
-n = Value at POR	'1' = Bit is set	'0' = Bit is cleared      x = Bit is unknown

- bit 15      **AMPON:** Op Amp Enable/On bit  
 1 = Enables op amp modules if their respective AMPENx bits are also asserted  
 0 = Disables all op amp modules
- bit 14-3    **Unimplemented:** Read as '0'
- bit 2      **AMPEN3:** Op Amp #3 Enable bit  
 1 = Enables Op Amp #3 if the AMPON bit is also asserted  
 0 = Disables Op Amp #3
- bit 1      **AMPEN2:** Op Amp #2 Enable bit  
 1 = Enables Op Amp #2 if the AMPON bit is also asserted  
 0 = Disables Op Amp #2
- bit 0      **AMPEN1:** Op Amp #1 Enable bit  
 1 = Enables Op Amp #1 if the AMPON bit is also asserted  
 0 = Disables Op Amp #1

# dsPIC33CK256MP508 FAMILY

## REGISTER 27-2: AMPCON1H: OP AMP CONTROL REGISTER HIGH

U-0	U-0	U-0	U-0	U-0	U-0	U-0	U-0
—	—	—	—	—	—	—	—
bit 15							bit 8

U-0	U-0	U-0	U-0	U-0	R/W-0	R/W-0	R/W-0
—	—	—	—	—	NCHDIS3	NCHDIS2	NCHDIS1
bit 7					bit 0		

### Legend:

R = Readable bit

W = Writable bit

U = Unimplemented bit, read as '0'

-n = Value at POR

'1' = Bit is set

'0' = Bit is cleared

x = Bit is unknown

bit 15-3      **Unimplemented:** Read as '0'

bit 2      **NCHDIS3:** Op Amp #3 N Channel Disable bit

1 = Disables Op Amp #3 N channels input stage; reduced INL, but lowered input voltage range

0 = Wide input range for Op Amp #3

bit 1      **NCHDIS2:** Op Amp #2 N Channel Disable bit

1 = Disables Op Amp #2 N channels input stage; reduced INL, but lowered input voltage range

0 = Wide input range for Op Amp #2

bit 0      **NCHDIS1:** Op Amp #1 N Channel Disable bit

1 = Disables Op Amp #1 N channels input stage; reduced INL, but lowered input voltage range

0 = Wide input range for Op Amp #1

# dsPIC33CK256MP508 FAMILY

---

NOTES:

## 28.0 DEADMAN TIMER (DMT)

**Note 1:** This data sheet summarizes the features of the dsPIC33CK256MP508 family of devices. It is not intended to be a comprehensive reference source. To complement the information in this data sheet, refer to “**Deadman Timer (DMT)**” ([www.microchip.com/DS70005155](http://www.microchip.com/DS70005155)) in the “*dsPIC33/PIC24 Family Reference Manual*”.

The primary function of the Deadman Timer (DMT) is to interrupt the processor in the event of a software malfunction. The DMT, which works on the system clock, is a free-running instruction fetch timer, which is clocked

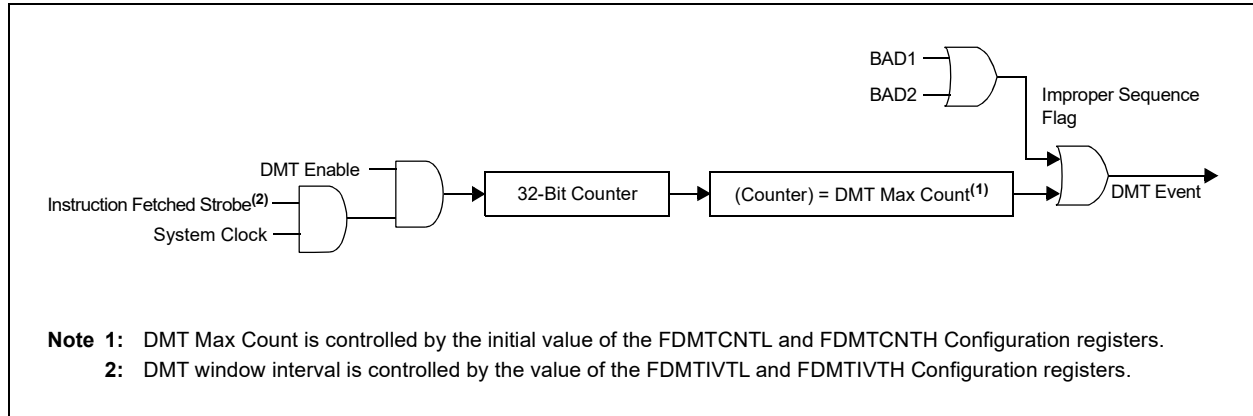
whenever an instruction fetch occurs, until a count match occurs. Instructions are not fetched when the processor is in Sleep mode.

DMT can be enabled in the Configuration fuse or by software in the DMTCON register by setting the ON bit. The DMT consists of a 32-bit counter with a time-out count match value, as specified by the two 16-bit Configuration Fuse registers: FDMTCNTL and FDMTCNTH. A DMT event results in an interrupt.

A DMT is typically used in mission-critical and safety-critical applications, where any single failure of the software functionality and sequencing must be detected.

Figure 28-1 shows a block diagram of the Deadman Timer module.

**FIGURE 28-1: DEADMAN TIMER BLOCK DIAGRAM**



# dsPIC33CK256MP508 FAMILY

## 28.1 Deadman Timer Control Registers

### REGISTER 28-1: DMTCON: DEADMAN TIMER CONTROL REGISTER

SO-0	U-0	U-0	U-0	U-0	U-0	U-0	U-0
ON <sup>(1,2)</sup>	—	—	—	—	—	—	—
bit 15							bit 8

U-0	U-0	U-0	U-0	U-0	U-0	U-0	U-0
—	—	—	—	—	—	—	—
bit 7							bit 0

<b>Legend:</b>	SO = Settable Only bit		
R = Readable bit	W = Writable bit	U = Unimplemented bit, read as '0'	
-n = Value at POR	'1' = Bit is set	'0' = Bit is cleared	x = Bit is unknown

bit 15      **ON:** DMT Module Enable bit<sup>(1,2)</sup>  
                  1 = Deadman Timer module is enabled  
                  0 = Deadman Timer module is not enabled

bit 14-0      **Unimplemented:** Read as '0'

**Note 1:** This bit has control only when DMTDIS = 0 in the FDMT register.  
**Note 2:** DMT cannot be disabled in software. Writing '0' to this bit has no effect.

### REGISTER 28-2: DMTPRECLR: DEADMAN TIMER PRECLEAR REGISTER

R/W-0	R/W-0	R/W-0	R/W-0	R/W-0	R/W-0	R/W-0	R/W-0
STEP1[7:0] <sup>(1)</sup>							
bit 15							bit 8

U-0	U-0	U-0	U-0	U-0	U-0	U-0	U-0
—	—	—	—	—	—	—	—
bit 7							bit 0

<b>Legend:</b>	W = Writable bit			U = Unimplemented bit, read as '0'	
R = Readable bit					
-n = Value at POR	'1' = Bit is set	'0' = Bit is cleared	x = Bit is unknown		

bit 15-8      **STEP1[7:0]:** DMT Preclear Enable bits<sup>(1)</sup>  
                  01000000 = Enables the Deadman Timer preclear (Step 1)  
                  All Other  
                  Write Patterns = Sets the BAD1 flag

bit 7-0      **Unimplemented:** Read as '0'

**Note 1:** These bits are cleared when a DMT Reset event occurs. STEP1[7:0] bits are also cleared if the STEP2[7:0] bits are loaded with the correct value in the correct sequence.



# dsPIC33CK256MP508 FAMILY

## REGISTER 28-3: DMTCLR: DEADMAN TIMER CLEAR REGISTER

U-0	U-0	U-0	U-0	U-0	U-0	U-0	U-0
—	—	—	—	—	—	—	—
bit 15							bit 8

R/W-0	R/W-0	R/W-0	R/W-0	R/W-0	R/W-0	R/W-0	R/W-0
STEP2[7:0] <sup>(1)</sup>							
bit 7							bit 0

### Legend:

R = Readable bit	W = Writable bit	U = Unimplemented bit, read as '0'
-n = Value at POR	'1' = Bit is set	'0' = Bit is cleared      x = Bit is unknown

bit 15-8      **Unimplemented:** Read as '0'

bit 7-0      **STEP2[7:0]:** DMT Clear Timer bits<sup>(1)</sup>

00001000 = Clears STEP1[7:0], STEP2[7:0] and the Deadman Timer if preceded by the correct loading of the STEP1[7:0] bits in the correct sequence. The write to these bits may be verified by reading the DMTCNTL/H register and observing the counter being reset.

All Other

Write Patterns = Sets the BAD2 bit; the value of STEP1[7:0] will remain unchanged and the new value being written to STEP2[7:0] will be captured.

**Note 1:** These bits are cleared when a DMT Reset event occurs.

# dsPIC33CK256MP508 FAMILY

## REGISTER 28-4: DMTSTAT: DEADMAN TIMER STATUS REGISTER

U-0	U-0	U-0	U-0	U-0	U-0	U-0	U-0
—	—	—	—	—	—	—	—
bit 15						bit 8	

HC/R-0	HC/R-0	HC/R-0	U-0	U-0	U-0	U-0	R-0
BAD1 <sup>(1)</sup>	BAD2 <sup>(1)</sup>	DMTEVENT <sup>(1)</sup>	—	—	—	—	WINOPN
bit 7						bit 0	

<b>Legend:</b>	HC = Hardware Clearable bit
R = Readable bit	W = Writable bit
-n = Value at POR	'1' = Bit is set
	U = Unimplemented bit, read as '0'
	'0' = Bit is cleared
	x = Bit is unknown

- bit 15-8     **Unimplemented:** Read as '0'
- bit 7       **BAD1:** Deadman Timer Bad STEP1[7:0] Value Detect bit<sup>(1)</sup>
  - 1 = Incorrect STEP1[7:0] value was detected
  - 0 = Incorrect STEP1[7:0] value was not detected
- bit 6       **BAD2:** Deadman Timer Bad STEP2[7:0] Value Detect bit<sup>(1)</sup>
  - 1 = Incorrect STEP2[7:0] value was detected
  - 0 = Incorrect STEP2[7:0] value was not detected
- bit 5       **DMTEVENT:** Deadman Timer Event bit<sup>(1)</sup>
  - 1 = Deadman Timer event was detected (counter expired, or bad STEP1[7:0] or STEP2[7:0] value was entered prior to counter increment)
  - 0 = Deadman Timer event was not detected
- bit 4-1     **Unimplemented:** Read as '0'
- bit 0       **WINOPN:** Deadman Timer Clear Window bit
  - 1 = Deadman Timer clear window is open
  - 0 = Deadman Timer clear window is not open

**Note 1:** BAD1, BAD2 and DMTEVENT bits are cleared only on a Reset.

# dsPIC33CK256MP508 FAMILY

## REGISTER 28-5: DMTCNTL: DEADMAN TIMER COUNT REGISTER LOW

R-0	R-0	R-0	R-0	R-0	R-0	R-0	R-0
COUNTER[15:8]							
bit 15							
bit 8							

R-0	R-0	R-0	R-0	R-0	R-0	R-0	R-0
COUNTER[7:0]							
bit 7							
bit 0							

### Legend:

R = Readable bit

W = Writable bit

U = Unimplemented bit, read as '0'

-n = Value at POR

'1' = Bit is set

'0' = Bit is cleared

x = Bit is unknown

bit 15-0      **COUNTER[15:0]:** Read Current Contents of Lower DMT Counter bits

## REGISTER 28-6: DMTCNTH: DEADMAN TIMER COUNT REGISTER HIGH

R-0	R-0	R-0	R-0	R-0	R-0	R-0	R-0
COUNTER[31:24]							
bit 15							
bit 8							

R-0	R-0	R-0	R-0	R-0	R-0	R-0	R-0
COUNTER[23:16]							
bit 7							
bit 0							

### Legend:

R = Readable bit

W = Writable bit

U = Unimplemented bit, read as '0'

-n = Value at POR

'1' = Bit is set

'0' = Bit is cleared

x = Bit is unknown

bit 15-0      **COUNTER[31:16]:** Read Current Contents of Higher DMT Counter bits

# dsPIC33CK256MP508 FAMILY

## REGISTER 28-7: DMT PSCNTL: DMT POST-CONFIGURE COUNT STATUS REGISTER LOW

R-y	R-y	R-y	R-y	R-y	R-y	R-y	R-y
PSCNT[15:8]							
bit 15							bit 8

Ry	R-y	R-y	R-y	R-y	R-y	R-y	R-y
PSCNT[7:0]							
bit 7							bit 0

<b>Legend:</b>	y = Value from Configuration bit on POR						
R = Readable bit	W = Writable bit	U = Unimplemented bit, read as '0'					
-n = Value at POR	'1' = Bit is set	'0' = Bit is cleared	x = Bit is unknown				

bit 15-0 **PSCNT[15:0]:** Lower DMT Instruction Count Value Configuration Status bits  
 This is always the value of the FDMTCNTL Configuration register.

## REGISTER 28-8: DMT PSCNTH: DMT POST-CONFIGURE COUNT STATUS REGISTER HIGH

R-y	R-y	R-y	R-y	R-y	R-y	R-y	R-y
PSCNT[31:24]							
bit 15							bit 8

R-y	R-y	R-y	R-y	R-y	R-y	R-y	R-y
PSCNT[23:16]							
bit 7							bit 0

<b>Legend:</b>	y = Value from Configuration bit on POR						
R = Readable bit	W = Writable bit	U = Unimplemented bit, read as '0'					
-n = Value at POR	'1' = Bit is set	'0' = Bit is cleared	x = Bit is unknown				

bit 15-0 **PSCNT[31:16]:** Higher DMT Instruction Count Value Configuration Status bits  
 This is always the value of the FDMTCNTH Configuration register.

# dsPIC33CK256MP508 FAMILY

## REGISTER 28-9: DMTPSINTVL: DMT POST-CONFIGURE INTERVAL STATUS REGISTER LOW

R-y	R-y	R-y	R-y	R-y	R-y	R-y	R-y
PSINTV[15:8]							
bit 15				bit 8			

R-y	R-y	R-y	R-y	R-y	R-y	R-y	R-y
PSINTV[7:0]							
bit 7				bit 0			

<b>Legend:</b>	y = Value from Configuration bit on POR		
R = Readable bit	W = Writable bit	U = Unimplemented bit, read as '0'	
-n = Value at POR	'1' = Bit is set	'0' = Bit is cleared	x = Bit is unknown

bit 15-0      **PSINTV[15:0]:** Lower DMT Window Interval Configuration Status bits  
 This is always the value of the FDMTIVTL Configuration register.

## REGISTER 28-10: DMTPSINTVH: DMT POST-CONFIGURE INTERVAL STATUS REGISTER HIGH

R-y	R-y	R-y	R-y	R-y	R-y	R-y	R-y
PSINTV[31:24]							
bit 15				bit 8			

R-y	R-y	R-y	R-y	R-y	R-y	R-y	R-y
PSINTV[23:16]							
bit 7				bit 0			

<b>Legend:</b>	y = Value from Configuration bit on POR		
R = Readable bit	W = Writable bit	U = Unimplemented bit, read as '0'	
-n = Value at POR	'1' = Bit is set	'0' = Bit is cleared	x = Bit is unknown

bit 15-0      **PSINTV[31:16]:** Higher DMT Window Interval Configuration Status bits  
 This is always the value of the FDMTIVTH Configuration register.

# dsPIC33CK256MP508 FAMILY

---

## REGISTER 28-11: DMTHOLDREG: DMT HOLD REGISTER<sup>(1)</sup>

R-0	R-0	R-0	R-0	R-0	R-0	R-0	R-0
UPRCNT[15:8]							
bit 15							bit 8

R-0	R-0	R-0	R-0	R-0	R-0	R-0	R-0
UPRCNT[7:0]							
bit 7							bit 0

### Legend:

R = Readable bit

W = Writable bit

U = Unimplemented bit, read as '0'

-n = Value at POR

'1' = Bit is set

'0' = Bit is cleared

x = Bit is unknown

bit 15-0      **UPRCNT[15:0]:** DMTCNTH Register Value when DMTCNTL and DMTCNTH were Last Read bits

**Note 1:** The DMTHOLDREG register is initialized to '0' on Reset, and is only loaded when the DMTCNTL and DMTCNTH registers are read.

# dsPIC33CK256MP508 FAMILY

## 29.0 POWER-SAVING FEATURES

**Note 1:** This data sheet summarizes the features of the dsPIC33CK256MP508 family of devices. It is not intended to be a comprehensive reference source. To complement the information in this data sheet, refer to “**Watchdog Timer and Power-Saving Modes**” ([www.microchip.com/DS70615](http://www.microchip.com/DS70615)) in the “*dsPIC33/PIC24 Family Reference Manual*”.

The dsPIC33CK256MP508 family devices provide the ability to manage power consumption by selectively managing clocking to the CPU and the peripherals. In general, a lower clock frequency and a reduction in the number of peripherals being clocked constitutes lower consumed power.

dsPIC33CK256MP508 family devices can manage power consumption in four ways:

- Clock Frequency
- Instruction-Based Sleep and Idle modes
- Software-Controlled Doze mode
- Selective Peripheral Control in Software

Combinations of these methods can be used to selectively tailor an application’s power consumption while still maintaining critical application features, such as timing-sensitive communications.

## 29.1 Clock Frequency and Clock Switching

The dsPIC33CK256MP508 family devices allow a wide range of clock frequencies to be selected under application control. If the system clock configuration is not locked, users can choose low-power or high-precision oscillators by simply changing the NOSC<sub>x</sub> bits (OSCCON[10:8]). The process of changing a system clock during operation, as well as limitations to the process, are discussed in more detail in [Section 9.0 “Oscillator with High-Frequency PLL”](#).

## 29.2 Instruction-Based Power-Saving Modes

The dsPIC33CK256MP508 family devices have two special power-saving modes that are entered through the execution of a special PWRSAV instruction. Sleep mode stops clock operation and halts all code execution. Idle mode halts the CPU and code execution, but allows peripheral modules to continue operation. The assembler syntax of the PWRSAV instruction is shown in [Example 29-1](#).

**Note:** SLEEP\_MODE and IDLE\_MODE are constants defined in the assembler include file for the selected device.

Sleep and Idle modes can be exited as a result of an enabled interrupt, WDT time-out or a device Reset. When the device exits these modes, it is said to “wake-up”.

### EXAMPLE 29-1: PWRSAV INSTRUCTION SYNTAX IN ASSEMBLY

```
PWRSAV #SLEEP_MODE    ; Put the device into Sleep mode
PWRSAV #IDLE_MODE     ; Put the device into Idle mode
```

### EXAMPLE 29-2: PWRSAV INSTRUCTION SYNTAX IN C LANGUAGE

```
Sleep()    // Put the device into Sleep mode
Idle ()    // Put the device into Idle mode
```

# dsPIC33CK256MP508 FAMILY

## 29.2.1 SLEEP MODE

The following occurs in Sleep mode:

- The system clock source is shut down. If an on-chip oscillator is used, it is turned off.
- The device current consumption is reduced to a minimum, provided that no I/O pin is sourcing current.
- The Fail-Safe Clock Monitor does not operate, since the system clock source is disabled.
- The LPRC clock continues to run in Sleep mode if the WDT is enabled.
- The WDT, if enabled, is automatically cleared prior to entering Sleep mode.
- Some device features or peripherals can continue to operate. This includes items such as the Input Change Notification on the I/O ports or peripherals that use an External Clock input.
- Any peripheral that requires the system clock source for its operation is disabled.

The device wakes up from Sleep mode on any of the these events:

- Any interrupt source that is individually enabled
- Any form of device Reset
- A WDT time-out

On wake-up from Sleep mode, the processor restarts with the same clock source that was active when Sleep mode was entered.

For optimal power savings, the regulators can be configured to go into standby when Sleep mode is entered by clearing the VREGS (RCON[8]) bit (default configuration).

If the application requires a faster wake-up time, and can accept higher current requirements, the VREGS (RCON[8]) bit can be set to keep the regulators active during Sleep mode. The available Low-Power Sleep modes are shown in [Table 29-1](#). Additional regulator information is available in [Section 30.4 “On-Chip Voltage Regulators”](#).

**TABLE 29-1: LOW-POWER SLEEP MODES**

Relative Power	LPWREN	VREGS	MODE
Highest	0	1	Full power, active
—	0	0	Full power, standby
—	1 <sup>(1)</sup>	1	Low power, active
Lowest	1 <sup>(1)</sup>	0	Low power, standby

**Note 1:** Low-Power modes, when LPWREN = 1, can only be used in the industrial temperature range.

## 29.2.2 IDLE MODE

The following occurs in Idle mode:

- The CPU stops executing instructions.
- The WDT is automatically cleared.
- The system clock source remains active. By default, all peripheral modules continue to operate normally from the system clock source, but can also be selectively disabled (see [Section 29.4 “Peripheral Module Disable”](#)).
- If the WDT or FSCM is enabled, the LPRC also remains active.

The device wakes from Idle mode on any of these events:

- Any interrupt that is individually enabled
- Any device Reset
- A WDT time-out

On wake-up from Idle mode, the clock is reapplied to the CPU and instruction execution will begin (2-4 clock cycles later), starting with the instruction following the `PWRSVAV` instruction or the first instruction in the ISR.

All peripherals also have the option to discontinue operation when Idle mode is entered to allow for increased power savings. This option is selectable in the control register of each peripheral; for example, the SIDL bit in the Timer1 Control register (T1CON[13]).

## 29.2.3 INTERRUPTS COINCIDENT WITH POWER SAVE INSTRUCTIONS

Any interrupt that coincides with the execution of a `PWRSVAV` instruction is held off until entry into Sleep or Idle mode has completed. The device then wakes up from Sleep or Idle mode.



## 29.3 Doze Mode

The preferred strategies for reducing power consumption are changing clock speed and invoking one of the power-saving modes. In some circumstances, this cannot be practical. For example, it may be necessary for an application to maintain uninterrupted synchronous communication, even while it is doing nothing else. Reducing system clock speed can introduce communication errors, while using a power-saving mode can stop communications completely.

Doze mode is a simple and effective alternative method to reduce power consumption while the device is still executing code. In this mode, the system clock continues to operate from the same source and at the same speed. Peripheral modules continue to be clocked at the same speed, while the CPU clock speed is reduced. Synchronization between the two clock domains is maintained, allowing the peripherals to access the SFRs while the CPU executes code at a slower rate.

Doze mode is enabled by setting the DOZEN bit (CLKDIV[11]). The ratio between peripheral and core clock speed is determined by the DOZE[2:0] bits (CLKDIV[14:12]). There are eight possible configurations, from 1:1 to 1:128, with 1:1 being the default setting.

Programs can use Doze mode to selectively reduce power consumption in event-driven applications. This allows clock-sensitive functions, such as synchronous communications, to continue without interruption while the CPU idles, waiting for something to invoke an interrupt routine. An automatic return to full-speed CPU operation on interrupts can be enabled by setting the ROI bit (CLKDIV[15]). It takes two doze clocks for the CPU to resume full speed; one cycle to come out of the Doze mode and the next cycle to start the clocks. By default, interrupt events have no effect on Doze mode operation.

## 29.4 Peripheral Module Disable

The Peripheral Module Disable (PMD) registers provide a method to disable a peripheral module by stopping all clock sources supplied to that module. When a peripheral is disabled using the appropriate PMD control bit, the peripheral is in a minimum power consumption state. The control and status registers associated with the peripheral are also disabled, so writes to those registers do not have any effect and read values are invalid.

A peripheral module is enabled only if both the associated bit in the PMD register is cleared and the peripheral is supported by the specific dsPIC® DSC variant. If the peripheral is present in the device, it is enabled in the PMD register by default.

**Note 1:** If a PMD bit is set, the corresponding module is disabled after a delay of one instruction cycle. Similarly, if a PMD bit is cleared, the corresponding module is enabled after a delay of one instruction cycle (assuming the module control registers are already configured to enable module operation).

## 29.5 Power-Saving Resources

Many useful resources are provided on the main product page of the Microchip website for the devices listed in this data sheet. This product page contains the latest updates and additional information.

### 29.5.1 KEY RESOURCES

- **“Watchdog Timer and Power-Saving Modes”** (DS70615) in the *“dsPIC33/PIC24 Family Reference Manual”*
- Code Samples
- Application Notes
- Software Libraries
- Webinars
- All related *“dsPIC33/PIC24 Family Reference Manual”* Sections
- Development Tools

# dsPIC33CK256MP508 FAMILY

## REGISTER 29-1: PMD1: PERIPHERAL MODULE DISABLE 1 CONTROL REGISTER

U-0	U-0	U-0	U-0	R/W-0	R/W-0	R/W-0	U-0
—	—	—	—	T1MD	QE11MD	PWMMD	—
bit 15				bit 8			

R/W-0	R/W-0	R/W-0	R/W-0	R/W-0	U-0	R/W-0	R/W-0
I2C1MD	U2MD	U1MD	SPI2MD	SPI1MD	—	C1MD <sup>(1)</sup>	ADC1MD
bit 7				bit 0			

### Legend:

R = Readable bit

W = Writable bit

U = Unimplemented bit, read as '0'

-n = Value at POR

'1' = Bit is set

'0' = Bit is cleared

x = Bit is unknown

- bit 15-12 **Unimplemented:** Read as '0'
- bit 11 **T1MD:** Timer1 Module Disable bit  
1 = Timer1 module is disabled  
0 = Timer1 module is enabled
- bit 10 **QE11MD:** QE11 Module Disable bit  
1 = QE11 module is disabled  
0 = QE11 module is enabled
- bit 9 **PWMMD:** PWM Module Disable bit  
1 = PWM module is disabled  
0 = PWM module is enabled
- bit 8 **Unimplemented:** Read as '0'
- bit 7 **I2C1MD:** I2C1 Module Disable bit  
1 = I2C1 module is disabled  
0 = I2C1 module is enabled
- bit 6 **U2MD:** UART2 Module Disable bit  
1 = UART2 module is disabled  
0 = UART2 module is enabled
- bit 5 **U1MD:** UART1 Module Disable bit  
1 = UART1 module is disabled  
0 = UART1 module is enabled
- bit 4 **SPI2MD:** SPI2 Module Disable bit  
1 = SPI2 module is disabled  
0 = SPI2 module is enabled
- bit 3 **SPI1MD:** SPI1 Module Disable bit  
1 = SPI1 module is disabled  
0 = SPI1 module is enabled
- bit 2 **Unimplemented:** Read as '0'
- bit 1 **C1MD:** CAN1 Module Disable bit<sup>(1)</sup>  
1 = CAN1 module is disabled  
0 = CAN1 module is enabled
- bit 0 **ADC1MD:** ADC Module Disable bit  
1 = ADC module is disabled  
0 = ADC module is enabled

**Note 1:** Availability is dependent on the supported peripherals, refer to [Table 1](#) and [Table 2](#).

# dsPIC33CK256MP508 FAMILY

## REGISTER 29-2: PMD2: PERIPHERAL MODULE DISABLE 2 CONTROL REGISTER

U-0	U-0	U-0	U-0	U-0	U-0	U-0	R/W-0
—	—	—	—	—	—	—	CCP9MD
bit 15							bit 8

R/W-0	R/W-0	R/W-0	R/W-0	R/W-0	R/W-0	R/W-0	R/W-0
CCP8MD	CCP7MD	CCP6MD	CCP5MD	CCP4MD	CCP3MD	CCP2MD	CCP1MD
bit 7							bit 0

### Legend:

R = Readable bit	W = Writable bit	U = Unimplemented bit, read as '0'
-n = Value at POR	'1' = Bit is set	'0' = Bit is cleared
		x = Bit is unknown

- bit 15-9     **Unimplemented:** Read as '0'
- bit 8       **CCP9MD:** M CCP9 Module Disable bit  
             1 = M CCP9 module is disabled  
             0 = M CCP9 module is enabled
- bit 7       **CCP8MD:** S CCP8 Module Disable bit  
             1 = S CCP8 module is disabled  
             0 = S CCP8 module is enabled
- bit 6       **CCP7MD:** S CCP7 Module Disable bit  
             1 = S CCP7 module is disabled  
             0 = S CCP7 module is enabled
- bit 5       **CCP6MD:** S CCP6 Module Disable bit  
             1 = S CCP6 module is disabled  
             0 = S CCP6 module is enabled
- bit 4       **CCP5MD:** S CCP5 Module Disable bit  
             1 = S CCP5 module is disabled  
             0 = S CCP5 module is enabled
- bit 3       **CCP4MD:** S CCP4 Module Disable bit  
             1 = S CCP4 module is disabled  
             0 = S CCP4 module is enabled
- bit 2       **CCP3MD:** S CCP3 Module Disable bit  
             1 = S CCP3 module is disabled  
             0 = S CCP3 module is enabled
- bit 1       **CCP2MD:** S CCP2 Module Disable bit  
             1 = S CCP2 module is disabled  
             0 = S CCP2 module is enabled
- bit 0       **CCP1MD:** S CCP1 Module Disable bit  
             1 = S CCP1 module is disabled  
             0 = S CCP1 module is enabled

# dsPIC33CK256MP508 FAMILY

## REGISTER 29-3: PMD3: PERIPHERAL MODULE DISABLE 3 CONTROL REGISTER

U-0	U-0	U-0	U-0	U-0	U-0	U-0	R/W-0
—	—	—	—	—	—	—	PMPMD <sup>(1)</sup>
bit 15							bit 8

R/W-0	U-0	R/W-0	U-0	R/W-0	R/W-0	R/W-0	U-0
CRCMD	—	QE12MD	—	U3MD	I2C3MD	I2C2MD	—
bit 7							bit 0

### Legend:

R = Readable bit                      W = Writable bit                      U = Unimplemented bit, read as '0'  
 -n = Value at POR                      '1' = Bit is set                      '0' = Bit is cleared                      x = Bit is unknown

- bit 15-9        **Unimplemented:** Read as '0'
- bit 8         **PMPMD:** PMP Module Disable bit<sup>(1)</sup>  
                  1 = PMP module is disabled  
                  0 = PMP module is enabled
- bit 7         **CRCMD:** CRC Module Disable bit  
                  1 = CRC module is disabled  
                  0 = CRC module is enabled
- bit 6         **Unimplemented:** Read as '0'
- bit 5         **QE12MD:** QE12 Module Disable bit  
                  1 = QE12 module is disabled  
                  0 = QE12 module is enabled
- bit 4         **Unimplemented:** Read as '0'
- bit 3         **U3MD:** UART3 Module Disable bit  
                  1 = UART3 module is disabled  
                  0 = UART3 module is enabled
- bit 2         **I2C3MD:** I2C3 Module Disable bit  
                  1 = I2C3 module is disabled  
                  0 = I2C3 module is enabled
- bit 1         **I2C2MD:** I2C2 Module Disable bit  
                  1 = I2C2 module is disabled  
                  0 = I2C2 module is enabled
- bit 0         **Unimplemented:** Read as '0'

**Note 1:** Availability is dependent on the supported peripherals, refer to [Table 1](#) and [Table 2](#).

# dsPIC33CK256MP508 FAMILY

## REGISTER 29-4: PMD4: PERIPHERAL MODULE DISABLE 4 CONTROL REGISTER

U-0	U-0	U-0	U-0	U-0	U-0	U-0	U-0
—	—	—	—	—	—	—	—
bit 15							bit 8

U-0	U-0	U-0	U-0	R/W-0	U-0	U-0	U-0
—	—	—	—	REFOMD	—	—	—
bit 7							bit 0

### Legend:

R = Readable bit

W = Writable bit

U = Unimplemented bit, read as '0'

-n = Value at POR

'1' = Bit is set

'0' = Bit is cleared

x = Bit is unknown

bit 15-4     **Unimplemented:** Read as '0'

bit 3        **REFOMD:** Reference Clock Module Disable bit

1 = Reference clock module is disabled

0 = Reference clock module is enabled

bit 2-0     **Unimplemented:** Read as '0'

# dsPIC33CK256MP508 FAMILY

## REGISTER 29-5: PMD6: PERIPHERAL MODULE DISABLE 6 CONTROL REGISTER

U-0	U-0	U-0	U-0	R/W-0	R/W-0	R/W-0	R/W-0
—	—	—	—	DMA3MD	DMA2MD	DMA1MD	DMA0MD
bit 15				bit 8			

U-0	U-0	U-0	U-0	U-0	U-0	U-0	R/W-0
—	—	—	—	—	—	—	SPI3MD
bit 7							bit 0

### Legend:

R = Readable bit	W = Writable bit	U = Unimplemented bit, read as '0'
-n = Value at POR	'1' = Bit is set	'0' = Bit is cleared      x = Bit is unknown

- bit 15-12      **Unimplemented:** Read as '0'
- bit 11        **DMA3MD:** DMA3 Module Disable bit  
1 = DMA3 module is disabled  
0 = DMA3 module is enabled
- bit 10        **DMA2MD:** DMA2 Module Disable bit  
1 = DMA2 module is disabled  
0 = DMA2 module is enabled
- bit 9         **DMA1MD:** DMA1 Module Disable bit  
1 = DMA1 module is disabled  
0 = DMA1 module is enabled
- bit 8         **DMA0MD:** DMA0 Module Disable bit  
1 = DMA0 module is disabled  
0 = DMA0 module is enabled
- bit 7-1       **Unimplemented:** Read as '0'
- bit 0         **SPI3MD:** SPI3 Module Disable bit  
1 = SPI3 module is disabled  
0 = SPI3 module is enabled

# dsPIC33CK256MP508 FAMILY

## REGISTER 29-6: PMD7: PERIPHERAL MODULE DISABLE 7 CONTROL REGISTER

U-0	U-0	U-0	U-0	U-0	R/W-0	R/W-0	R/W-0
—	—	—	—	—	CMP3MD	CMP2MD	CMP1MD
bit 15					bit 8		

U-0	U-0	U-0	U-0	R/W-0	U-0	U-0	U-0
—	—	—	—	PTGMD	—	—	—
bit 7				bit 0			

### Legend:

R = Readable bit

W = Writable bit

U = Unimplemented bit, read as '0'

-n = Value at POR

'1' = Bit is set

'0' = Bit is cleared

x = Bit is unknown

- bit 15-11    **Unimplemented:** Read as '0'
- bit 10      **CMP3MD:** Comparator 3 Module Disable bit  
1 = Comparator 3 module is disabled  
0 = Comparator 3 module is enabled
- bit 9        **CMP2MD:** Comparator 2 Module Disable bit  
1 = Comparator 2 module is disabled  
0 = Comparator 2 module is enabled
- bit 8        **CMP1MD:** Comparator 1 Module Disable bit  
1 = Comparator 1 module is disabled  
0 = Comparator 1 module is enabled
- bit 7-4     **Unimplemented:** Read as '0'
- bit 3        **PTGMD:** PTG Module Disable bit  
1 = PTG module is disabled  
0 = PTG module is enabled
- bit 2-0     **Unimplemented:** Read as '0'

# dsPIC33CK256MP508 FAMILY

## REGISTER 29-7: PMD8: PERIPHERAL MODULE DISABLE 8 CONTROL REGISTER

U-0	U-0	R/W-0	R/W-0	R/W-0	U-0	U-0	R/W-0
—	—	OPAMPMD	SENT2MD	SENT1MD	—	—	DMTMD
bit 15						bit 8	

U-0	U-0	R/W-0	R/W-0	R/W-0	R/W-0	R/W-0	U-0
—	—	CLC4MD	CLC3MD	CLC2MD	CLC1MD	BIASMD	—
bit 7						bit 0	

### Legend:

R = Readable bit

W = Writable bit

U = Unimplemented bit, read as '0'

-n = Value at POR

'1' = Bit is set

'0' = Bit is cleared

x = Bit is unknown

- bit 15-14     **Unimplemented:** Read as '0'
- bit 13       **OPAMPMD:** Op Amp Module Disable bit  
               1 = Op amp modules are disabled  
               0 = Op amp modules are enabled
- bit 12       **SENT2MD:** SENT2 Module Disable bit  
               1 = SENT2 module is disabled  
               0 = SENT2 module is enabled
- bit 11       **SENT1MD:** SENT1 Module Disable bit  
               1 = SENT1 module is disabled  
               0 = SENT1 module is enabled
- bit 10-9     **Unimplemented:** Read as '0'
- bit 8         **DMTMD:** Deadman Timer Module Disable bit  
               1 = DMT module is disabled  
               0 = DMT module is enabled
- bit 7-6      **Unimplemented:** Read as '0'
- bit 5         **CLC4MD:** CLC4 Module Disable bit  
               1 = CLC4 module is disabled  
               0 = CLC4 module is enabled
- bit 4         **CLC3MD:** CLC3 Module Disable bit  
               1 = CLC3 module is disabled  
               0 = CLC3 module is enabled
- bit 3         **CLC2MD:** CLC2 Module Disable bit  
               1 = CLC2 module is disabled  
               0 = CLC2 module is enabled
- bit 2         **CLC1MD:** CLC1 Module Disable bit  
               1 = CLC1 module is disabled  
               0 = CLC1 module is enabled
- bit 1         **BIASMD:** Constant-Current Source Module Disable bit  
               1 = Constant-current source module is disabled  
               0 = Constant-current source module is enabled
- bit 0         **Unimplemented:** Read as '0'



**TABLE 29-2: PMD REGISTERS**

Register	Bit 15	Bit14	Bit 13	Bit 12	Bit 11	Bit 10	Bit 9	Bit 8	Bit 7	Bit 6	Bit 5	Bit 4	Bit 3	Bit 2	Bit 1	Bit 0
PMD1	—	—	—	—	T1MD	QEIMD	PWMMD	—	I2C1MD	U2MD	U1MD	SPI2MD	SPI1MD	—	C1MD	ADC1MD
PMD2	—	—	—	—	—	—	—	CCP9MD	CCP8MD	CCP7MD	CCP6MD	CCP5MD	CCP4MD	CCP3MD	CCP2MD	CCP1MD
PMD3	—	—	—	—	—	—	—	PMPMD	CRCMD	—	QEI2MD	—	U3MD	I2C3MD	I2C2MD	—
PMD4	—	—	—	—	—	—	—	—	—	—	—	—	REFOMD	—	—	—
PMD6	—	—	—	—	DMA3MD	DMA2MD	DMA1MD	DMA0MD	—	—	—	—	—	—	—	SPI3MD
PMD7	—	—	—	—	—	CMP3MD	CMP2MD	CMP1MD	—	—	—	—	PTGMD	—	—	—
PMD8	—	—	OPAMPMD	SENT2MD	SENT1MD	—	—	DMTMD	—	—	CLC4MD	CLC3MD	CLC2MD	CLC1MD	BIASMD	—

# dsPIC33CK256MP508 FAMILY

---

NOTES:

# dsPIC33CK256MP508 FAMILY

## 30.0 SPECIAL FEATURES

**Note:** This data sheet summarizes the features of the dsPIC33CK256MP508 family of devices. It is not intended to be a comprehensive reference source. To complement the information in this data sheet, refer to the related section of the “dsPIC33/PIC24 Family Reference Manual”, which is available from the Microchip website ([www.microchip.com](http://www.microchip.com)).

The dsPIC33CK256MP508 family devices include several features intended to maximize application flexibility and reliability, and minimize cost through elimination of external components. These are:

- Flexible Configuration
- Watchdog Timer (WDT)
- Code Protection and CodeGuard™ Security
- JTAG Boundary Scan Interface
- In-Circuit Serial Programming™ (ICSP™)
- In-Circuit Emulation
- Brown-out Reset (BOR)

## 30.1 Configuration Bits

In dsPIC33CK256MP508 family devices, the Configuration Words are implemented as volatile memory. This means that configuration data will get loaded to volatile memory (from the Flash Configuration Words) each time the device is powered up. Configuration data are stored at the end of the on-chip program memory space, known as the Flash Configuration Words. Their specific locations are shown in Table 30-1. The configuration data are automatically loaded from the Flash Configuration Words to the proper Configuration Shadow registers during device Resets. The BSEQx bits (FBTSEQ[11:0]) determine which panel is the Active Partition at start-up and the Configuration Words from that panel are loaded into the Configuration Shadow registers.

**Note:** Configuration data are reloaded on all types of device Resets.

When creating applications for these devices, users should always specifically allocate the location of the Flash Configuration Words for configuration data in their code for the compiler. This is to make certain that program code is not stored in this address when the code is compiled. Program code executing out of configuration space will cause a device Reset.

**Note:** Performing a page erase operation on the last page of program memory clears the Flash Configuration Words.

**TABLE 30-1: dsPIC33CKXXXMPX0X CONFIGURATION ADDRESSES**

Register Name	Single Partition		Dual Partition, Active		Dual Partition, Inactive	
	256k	128k	256k	128k	256k	128k
FSEC <sup>(2)</sup>	0x02BF00	0x015F00	0x015F00	0x00AF00	0x415F00	0x40AF00
FBSLIM <sup>(2)</sup>	0x02BF10	0x015F10	0x015F10	0x00AF10	0x415F10	0x40AF10
FSIGN <sup>(2)</sup>	0x02BF14	0x015F14	0x015F14	0x00AF14	0x415F14	0x40AF14
FOSCSEL	0x02BF18	0x015F18	0x015F18	0x00AF18	0x415F18	0x40AF18
FOSC	0x02BF1C	0x015F1C	0x015F1C	0x00AF1C	0x415F1C	0x40AF1C
FWDT	0x02BF20	0x015F20	0x015F20	0x00AF20	0x415F20	0x40AF20
FPOR	0x02BF24	0x015F24	0x015F24	0x00AF24	0x415F24	0x40AF24
FICD	0x02BF28	0x015F28	0x015F28	0x00AF28	0x415F28	0x40AF28
FDMTIVTL	0x02BF2C	0x015F2C	0x015F2C	0x00AF2C	0x415F2C	0x40AF2C
FDMTIVTH	0x02BF30	0x015F30	0x015F30	0x00AF30	0x415F30	0x40AF30
FDMTCNTL	0x02BF34	0x015F34	0x015F34	0x00AF34	0x415F34	0x40AF34
FDMTCNTH	0x02BF38	0x015F38	0x015F38	0x00AF38	0x415F38	0x40AF38
FDMT	0x02BF3C	0x015F3C	0x015F3C	0x00AF3C	0x415F3C	0x40AF3C
FDEVOPT	0x02BF40	0x015F40	0x015F40	0x00AF40	0x415F40	0x40AF40
FALTREG	0x02BF44	0x015F44	0x015F44	0x00AF44	0x415F44	0x40AF44
FBTSEQ	0x02BFFC	0x015FFC	0x015FFC	0x00AFFC	0x415FFC	0x40AFFC
FBOOT <sup>(1)</sup>	0x801800					

**Note 1:** FBOOT resides in calibration memory space.

**Note 2:** Changes to the Inactive Partition Configuration Words affect how the Active Partition accesses the Inactive Partition.

# dsPIC33CK256MP508 FAMILY

**TABLE 30-2: dsPIC33CKXXMPX0X CONFIGURATION ADDRESSES**

Register Name	Single Partition		Dual Partition, Active		Dual Partition, Inactive	
	64k	32k	64k	32k	64k	32k
FSEC <sup>(2)</sup>	0x00AF00	0x005F00	0x005700	0x002F00	0x405700	0x402F00
FBSLIM <sup>(2)</sup>	0x00AF10	0x005F10	0x005710	0x002F10	0x405710	0x402F10
FSIGN <sup>(2)</sup>	0x00AF14	0x005F14	0x005714	0x002F14	0x405714	0x402F14
FOSCSEL	0x00AF18	0x005F18	0x005718	0x002F18	0x405718	0x402F18
FOSC	0x00AF1C	0x005F1C	0x00571C	0x002F1C	0x40571C	0x402F1C
FWDT	0x00AF20	0x005F20	0x005720	0x002F20	0x405720	0x402F20
FPOR	0x00AF24	0x005F24	0x005724	0x002F24	0x405724	0x402F24
FICD	0x00AF28	0x005F28	0x005728	0x002F28	0x405728	0x402F28
FDMTIVTL	0x00AF2C	0x005F2C	0x00572C	0x002F2C	0x40572C	0x402F2C
FDMTIVTH	0x00AF30	0x005F30	0x005730	0x002F30	0x405730	0x402F30
FDMTCNTL	0x00AF34	0x005F34	0x005734	0x002F34	0x405734	0x402F34
FDMTCNTH	0x00AF38	0x005F38	0x005738	0x002F38	0x405738	0x402F38
FDMT	0x00AF3C	0x005F3C	0x00573C	0x002F3C	0x40573C	0x402F3C
FDEVOPT	0x00AF40	0x005F40	0x005740	0x002F40	0x405740	0x402F40
FALTREG	0x00AF44	0x005F44	0x005744	0x002F44	0x405744	0x402F44
FBTSEQ	0x00AFFC	0x005FFC	0x0057FC	0x002FFC	0x4057FC	0x402FFC
FBOOT <sup>(1)</sup>	0x801800					

**Note 1:** FBOOT resides in calibration memory space.

**2:** Changes to the Inactive Partition Configuration Words affect how the Active Partition accesses the Inactive Partition.

**TABLE 30-3: CONFIGURATION REGISTERS MAP**

Register Name	Bits 23-16	Bit 15	Bit 14	Bit 13	Bit 12	Bit 11	Bit 10	Bit 9	Bit 8	Bit 7	Bit 6	Bit 5	Bit 4	Bit 3	Bit 2	Bit 1	Bit 0
FSEC	—	AIVTDIS	—	—	—	CSS[2:0]			CWRP	GSS[1:0]		GWRP	—	BSEN	BSS[1:0]		BWRP
FBSLIM	—	—	—	—	BSLIM[12:0]												
FSIGN	—	r <sup>(2)</sup>	—	—	—	—	—	—	—	—	—	—	—	—	—	—	—
FOSCSEL	—	—	—	—	—	—	—	—	—	IESO	—	—	—	—	FNOSC[2:0]		
FOSC	—	—	—	—	XTBST	XTCFG[1:0]		—	PLLKEN	FCKSM[1:0]		—	—	—	OSCIOFNC	POSCMD[1:0]	
FWDT	—	FWDTEN	SWDTPS[4:0]				WDTWIN[1:0]		WINDIS	RCLKSEL[1:0]		RWDTPS[4:0]					
FPOR	—	—	—	—	—	—	r <sup>(1)</sup>	—	—	—	BISTDIS	r <sup>(1)</sup>	r <sup>(1)</sup>	—	—	—	—
FICD	—	NOBTSWP	—	—	—	—	—	—	—	r <sup>(1)</sup>	—	JTAGEN	—	—	—	ICS[1:0]	
FDMTIVTL	—	DMTIVT[15:0]															
FDMTIVTH	—	DMTIVT[31:16]															
FDMTCNTL	—	DMTCNT[15:0]															
FDMTCNTH	—	DMTCNT[31:16]															
FDMT	—	—	—	—	—	—	—	—	—	—	—	—	—	—	—	—	DMTDIS
FDEVOPT	—	—	—	SPI2PIN	—	—	SMBEN	r <sup>(2)</sup>	r <sup>(2)</sup>	r <sup>(1)</sup>	—	ALT12C3	ALT12C2	ALT12C1	r <sup>(1)</sup>	—	—
FALTREG	—	—	CTXT4[2:0]			—	CTXT3[2:0]			—	CTXT2[2:0]			—	CTXT1[2:0]		
FBTSEQ	IBSEQ[11:4]		IBSEQ[3:0]				BSEQ[11:0]										
FBOOT	—	—	—	—	—	—	—	—	—	—	—	—	—	—	—	BTMODE[1:0]	

**Legend:** — = unimplemented bit, read as '1'; r = reserved bit.

**Note 1:** Bit reserved, maintain as '1'.

**2:** Bit reserved, maintain as '0'.

# dsPIC33CK256MP508 FAMILY

## REGISTER 30-1: FSEC CONFIGURATION REGISTER

U-1	U-1	U-1	U-1	U-1	U-1	U-1	U-1
—	—	—	—	—	—	—	—
bit 23							bit 16

R/PO-1	U-1	U-1	U-1	R/PO-1	R/PO-1	R/PO-1	R/PO-1
AIVTDIS	—	—	—	CSS[2:0]			CWRP
bit 15							bit 8

R/PO-1	R/PO-1	R/PO-1	U-1	R/PO-1	R/PO-1	R/PO-1	R/PO-1
GSS[1:0]		GWRP	—	BSEN	BSS[1:0]		BWRP
bit 7							bit 0

<b>Legend:</b>	PO = Program Once bit
R = Readable bit	W = Writable bit
-n = Value at POR	'1' = Bit is set
	U = Unimplemented bit, read as '0'
	'0' = Bit is cleared
	x = Bit is unknown

- bit 23-16 **Unimplemented:** Read as '1'
- bit 15 **AIVTDIS:** Alternate Interrupt Vector Table Disable bit
  - 1 = Disables AIVT
  - 0 = Enables AIVT
- bit 14-12 **Unimplemented:** Read as '1'
- bit 11-9 **CSS[2:0]:** Configuration Segment Code Flash Protection Level bits
  - 111 = No protection (other than CWRP write protection)
  - 110 = Standard security
  - 10x = Enhanced security
  - 0xx = High security
- bit 8 **CWRP:** Configuration Segment Write-Protect bit
  - 1 = Configuration Segment is not write-protected
  - 0 = Configuration Segment is write-protected
- bit 7-6 **GSS[1:0]:** General Segment Code Flash Protection Level bits
  - 11 = No protection (other than GWRP write protection)
  - 10 = Standard security
  - 0x = High security
- bit 5 **GWRP:** General Segment Write-Protect bit
  - 1 = User program memory is not write-protected
  - 0 = User program memory is write-protected
- bit 4 **Unimplemented:** Read as '1'
- bit 3 **BSEN:** Boot Segment Control bit
  - 1 = No Boot Segment
  - 0 = Boot Segment size is determined by BSLIM[12:0]
- bit 2-1 **BSS[1:0]:** Boot Segment Code Flash Protection Level bits
  - 11 = No protection (other than BWRP write protection)
  - 10 = Standard security
  - 0x = High security
- bit 0 **BWRP:** Boot Segment Write-Protect bit
  - 1 = User program memory is not write-protected
  - 0 = User program memory is write-protected

# dsPIC33CK256MP508 FAMILY

## REGISTER 30-2: FBSLIM CONFIGURATION REGISTER

U-1	U-1	U-1	U-1	U-1	U-1	U-1	U-1
—	—	—	—	—	—	—	—
bit 23							bit 16

U-1	U-1	U-1	R/PO-1	R/PO-1	R/PO-1	R/PO-1	R/PO-1
—	—	—	BSLIM[12:8]				
bit 15							bit 8

R/PO-1	R/PO-1	R/PO-1	R/PO-1	R/PO-1	R/PO-1	R/PO-1	R/PO-1
BSLIM[7:0]							
bit 7							bit 0

<b>Legend:</b>	PO = Program Once bit
R = Readable bit	W = Writable bit
-n = Value at POR	'1' = Bit is set
	'0' = Bit is cleared
	x = Bit is unknown
	U = Unimplemented bit, read as '0'

bit 23-13 **Unimplemented:** Read as '1'

bit 12-0 **BSLIM[12:0]:** Boot Segment Code Flash Page Address Limit bits

Contains the page address of the first active General Segment page. The value to be programmed is the inverted page address, such that programming additional '0's can only increase the Boot Segment size.

## REGISTER 30-3: FSIGN CONFIGURATION REGISTER

U-1	U-1	U-1	U-1	U-1	U-1	U-1	U-1
—	—	—	—	—	—	—	—
bit 23							bit 16

r-0	U-1	U-1	U-1	U-1	U-1	U-1	U-1
—	—	—	—	—	—	—	—
bit 15							bit 8

U-1	U-1	U-1	U-1	U-1	U-1	U-1	U-1
—	—	—	—	—	—	—	—
bit 7							bit 0

<b>Legend:</b>	r = Reserved bit	PO = Program Once bit
R = Readable bit	W = Writable bit	U = Unimplemented bit, read as '0'
-n = Value at POR	'1' = Bit is set	'0' = Bit is cleared
		x = Bit is unknown

bit 23-16 **Unimplemented:** Read as '1'

bit 15 **Reserved:** Maintain as '0'

bit 14-0 **Unimplemented:** Read as '1'

# dsPIC33CK256MP508 FAMILY

## REGISTER 30-4: FOSCSEL CONFIGURATION REGISTER

U-1	U-1	U-1	U-1	U-1	U-1	U-1	U-1
—	—	—	—	—	—	—	—
bit 23						bit 16	

U-1	U-1	U-1	U-1	U-1	U-1	U-1	U-1
—	—	—	—	—	—	—	—
bit 15						bit 8	

R/PO-1	U-1	U-1	U-1	U-1	R/PO-1	R/PO-1	R/PO-1
IESO	—	—	—	—	FNOSC[2:0]		
bit 7						bit 0	

<b>Legend:</b>	PO = Program Once bit
R = Readable bit	W = Writable bit
-n = Value at POR	'1' = Bit is set
	U = Unimplemented bit, read as '0'
	'0' = Bit is cleared
	x = Bit is unknown

- bit 23-8    **Unimplemented:** Read as '1'
- bit 7      **IESO:** Internal External Switchover bit
  - 1 = Internal External Switchover mode is enabled (Two-Speed Start-up is enabled)
  - 0 = Internal External Switchover mode is disabled (Two-Speed Start-up is disabled)
- bit 6-3    **Unimplemented:** Read as '1'
- bit 2-0    **FNOSC[2:0]:** Initial Oscillator Source Selection bits
  - 111 = Internal Fast RC (FRC) Oscillator with Postscaler
  - 110 = Backup Fast RC (BFRC)
  - 101 = LPRC Oscillator
  - 100 = Reserved
  - 011 = Primary Oscillator with PLL (XTPLL, HSPLL, ECPLL)
  - 010 = Primary (XT, HS, EC) Oscillator
  - 001 = Internal Fast RC Oscillator with PLL (FRCPLL)
  - 000 = Fast RC (FRC) Oscillator



# dsPIC33CK256MP508 FAMILY

## REGISTER 30-5: FOSC CONFIGURATION REGISTER

U-1	U-1	U-1	U-1	U-1	U-1	U-1	U-1
—	—	—	—	—	—	—	—
bit 23						bit 16	

U-1	U-1	U-1	R/PO-1	R/PO-1	R/PO-1	U-1	R/PO-1
—	—	—	XTBST	XTCFG[1:0]		—	PLLKEN <sup>(1)</sup>
bit 15						bit 8	

R/PO-1	R/PO-1	U-1	U-1	U-1	R/PO-1	R/PO-1	R/PO-1
FCKSM[1:0]		—	—	—	OSCIOfNC	POSCMD[1:0]	
bit 7						bit 0	

<b>Legend:</b>	PO = Program Once bit
R = Readable bit	W = Writable bit
-n = Value at POR	'1' = Bit is set
	'0' = Bit is cleared
	x = Bit is unknown
	U = Unimplemented bit, read as '0'

- bit 23-13    **Unimplemented:** Read as '1'
- bit 12      **XTBST:** Oscillator Kick-Start Programmability bit
  - 1 = Boosts the kick-start
  - 0 = Default kick-start
- bit 11-10   **XTCFG[1:0]:** Crystal Oscillator Drive Select bits
  - Current gain programmability for oscillator (output drive).
  - 11 = Gain3 (use for 24-32 MHz crystals)
  - 10 = Gain2 (use for 16-24 MHz crystals)
  - 01 = Gain1 (use for 8-16 MHz crystals)
  - 00 = Gain0 (use for 4-8 MHz crystals)
- bit 9        **Unimplemented:** Read as '1'
- bit 8        **PLLKEN:** PLL Lock Status Control bit<sup>(1)</sup>
  - 1 = PLL lock signal will be used to disable PLL clock output if lock is lost
  - 0 = PLL lock signal is not used; the PLL clock output will not be disabled if lock is lost
- bit 7-6     **FCKSM[1:0]:** Clock Switching Mode bits
  - 1x = Clock switching is disabled, Fail-Safe Clock Monitor is disabled
  - 01 = Clock switching is enabled, Fail-Safe Clock Monitor is disabled
  - 00 = Clock switching is enabled, Fail-Safe Clock Monitor is enabled
- bit 5-3     **Unimplemented:** Read as '1'
- bit 2        **OSCIOfNC:** OSCO Pin Function bit (except in XT and HS modes)
  - 1 = OSCO is the clock output
  - 0 = OSCO is the general purpose digital I/O pin
- bit 1-0     **POSCMD[1:0]:** Primary Oscillator Mode Select bits
  - 11 = Primary Oscillator is disabled
  - 10 = HS Crystal Oscillator mode (10 MHz-32 MHz)
  - 01 = XT Crystal Oscillator mode (3.5 MHz-10 MHz)
  - 00 = EC (External Clock) mode

**Note 1:** A time-out period will occur when the system clock switching logic requests the PLL clock source and the PLL is not already enabled.

# dsPIC33CK256MP508 FAMILY

## REGISTER 30-6: FWDT CONFIGURATION REGISTER

U-1	U-1	U-1	U-1	U-1	U-1	U-1	U-1
—	—	—	—	—	—	—	—
bit 23							bit 16

R/PO-1	R/PO-1	R/PO-1	R/PO-1	R/PO-1	R/PO-1	R/PO-1	R/PO-1
FWDTEN	SWDTPS[4:0]					WDTWIN[1:0]	
bit 15							bit 8

R/PO-1	R/PO-1	R/PO-1	R/PO-1	R/PO-1	R/PO-1	R/PO-1	R/PO-1
WINDIS	RCLKSEL[1:0]		RWDTPS[4:0]				
bit 7							bit 0

<b>Legend:</b>	PO = Program Once bit		
R = Readable bit	W = Writable bit	U = Unimplemented bit, read as '0'	
-n = Value at POR	'1' = Bit is set	'0' = Bit is cleared	x = Bit is unknown

- bit 23-16 **Unimplemented:** Read as '1'
- bit 15 **FWDTEN:** Watchdog Timer Enable bit  
 1 = WDT is enabled in hardware  
 0 = WDT controller via the ON bit (WDTCONL[15])
- bit 14-10 **SWDTPS[4:0]:** Sleep Mode Watchdog Timer Period Select bits  
 11111 = Divide by  $2^{31} = 214,748,3648$   
 11110 = Divide by  $2^{30} = 1,073,741,824$   
 ...  
 00001 = Divide by  $2^{1,2}$   
 00000 = Divide by  $2^{0,1}$
- bit 9-8 **WDTWIN[1:0]:** Watchdog Timer Window Select bits  
 11 = WDT window is 25% of the WDT period  
 10 = WDT window is 37.5% of the WDT period  
 01 = WDT window is 50% of the WDT period  
 00 = WDT Window is 75% of the WDT period
- bit 7 **WINDIS:** Watchdog Timer Window Enable bit  
 1 = Watchdog Timer is in Non-Window mode  
 0 = Watchdog Timer is in Window mode
- bit 6-5 **RCLKSEL[1:0]:** Watchdog Timer Clock Select bits  
 11 = LPRC clock  
 10 = Uses FRC when WINDIS = 0, system clock is not INTOSC/LPRC and device is not in Sleep; otherwise, uses INTOSC/LPRC  
 01 = Uses peripheral clock when system clock is not INTOSC/LPRC and device is not in Sleep; otherwise, uses INTOSC/LPRC  
 00 = Reserved
- bit 4-0 **RWDTPS[4:0]:** Run Mode Watchdog Timer Period Select bits  
 11111 = Divide by  $2^{31} = 2,147,483,648$   
 11110 = Divide by  $2^{30} = 1,073,741,824$   
 ...  
 00001 = Divide by  $2^{1,2}$   
 00000 = Divide by  $2^{0,1}$

# dsPIC33CK256MP508 FAMILY

## REGISTER 30-7: FPOR CONFIGURATION REGISTER

U-1	U-1	U-1	U-1	U-1	U-1	U-1	U-1
—	—	—	—	—	—	—	—
bit 23							bit 16

U-1	U-1	U-1	U-1	U-1	r-1	U-1	U-1
—	—	—	—	—	—	—	—
bit 15							bit 8

U-1	R/PO-1	r-1	r-1	U-1	U-1	U-1	U-1
—	BISTDIS <sup>(1)</sup>	—	—	—	—	—	—
bit 7							bit 0

<b>Legend:</b>	PO = Program Once bit	r = Reserved bit
R = Readable bit	W = Writable bit	U = Unimplemented bit, read as '0'
-n = Value at POR	'1' = Bit is set	'0' = Bit is cleared
		x = Bit is unknown

- bit 23-11    **Unimplemented:** Read as '1'
- bit 10      **Reserved:** Maintain as '1'
- bit 9-7     **Unimplemented:** Read as '1'
- bit 6       **BISTDIS:** Memory BIST Feature Disable bit<sup>(1)</sup>  
               1 = MBIST on Reset feature is disabled  
               0 = MBIST on Reset feature is enabled
- bit 5-4     **Reserved:** Maintain as '0b11'
- bit 3-0     **Unimplemented:** Read as '1'

**Note 1:** Applies to a Power-on Reset (POR) only.

# dsPIC33CK256MP508 FAMILY

## REGISTER 30-8: FICD CONFIGURATION REGISTER

U-1	U-1	U-1	U-1	U-1	U-1	U-1	U-1
—	—	—	—	—	—	—	—
bit 23							bit 16

R/PO-1	U-1	U-1	U-1	U-1	U-1	U-1	U-1
NOBTSWP	—	—	—	—	—	—	—
bit 15							bit 8

r-1	U-1	R/PO-1	U-1	U-1	U-1	R/PO-1	R/PO-1
—	—	JTAGEN	—	—	—	ICS[1:0]	
bit 7							bit 0

<b>Legend:</b>	PO = Program Once bit	r = Reserved bit
R = Readable bit	W = Writable bit	U = Unimplemented bit, read as '0'
-n = Value at POR	'1' = Bit is set	'0' = Bit is cleared
		x = Bit is unknown

- bit 23-16     **Unimplemented:** Read as '1'
- bit 15       **NOBTSWP:** BOOTSWP Instruction Disable bit
  - 1 = BOOTSWP instruction is disabled
  - 0 = BOOTSWP instruction is enabled
- bit 14-8     **Unimplemented:** Read as '1'
- bit 7        **Reserved:** Maintain as '1'
- bit 6        **Unimplemented:** Read as '1'
- bit 5        **JTAGEN:** JTAG Enable bit
  - 1 = JTAG port is enabled
  - 0 = JTAG port is disabled
- bit 4-2     **Unimplemented:** Read as '1'
- bit 1-0     **ICS[1:0]:** ICD Communication Channel Select bits
  - 11 = Communicates on PGC1 and PGD1
  - 10 = Communicates on PGC2 and PGD2
  - 01 = Communicates on PGC3 and PGD3
  - 00 = Reserved, do not use

# dsPIC33CK256MP508 FAMILY

## REGISTER 30-9: FDMTIVTL CONFIGURATION REGISTER

U-1	U-1	U-1	U-1	U-1	U-1	U-1	U-1
—	—	—	—	—	—	—	—
bit 23							bit 16

R/PO-1	R/PO-1	R/PO-1	R/PO-1	R/PO-1	R/PO-1	R/PO-1	R/PO-1
DMTIVT[15:8]							
bit 15							bit 8

R/PO-1	R/PO-1	R/PO-1	R/PO-1	R/PO-1	R/PO-1	R/PO-1	R/PO-1
DMTIVT[7:0]							
bit 7							bit 0

<b>Legend:</b>	PO = Program Once bit
R = Readable bit	W = Writable bit
-n = Value at POR	'1' = Bit is set
	'0' = Bit is cleared
	x = Bit is unknown
	U = Unimplemented bit, read as '0'

bit 23-16     **Unimplemented:** Read as '1'  
bit 15-0     **DMTIVT[15:0]:** DMT Window Interval Lower 16 bits

## REGISTER 30-10: FDMTIVTH CONFIGURATION REGISTER

U-1	U-1	U-1	U-1	U-1	U-1	U-1	U-1
—	—	—	—	—	—	—	—
bit 23							bit 16

R/PO-1	R/PO-1	R/PO-1	R/PO-1	R/PO-1	R/PO-1	R/PO-1	R/PO-1
DMTIVT[31:24]							
bit 15							bit 8

R/PO-1	R/PO-1	R/PO-1	R/PO-1	R/PO-1	R/PO-1	R/PO-1	R/PO-1
DMTIVT[23:16]							
bit 7							bit 0

<b>Legend:</b>	PO = Program Once bit
R = Readable bit	W = Writable bit
-n = Value at POR	'1' = Bit is set
	'0' = Bit is cleared
	x = Bit is unknown
	U = Unimplemented bit, read as '0'

bit 23-16     **Unimplemented:** Read as '1'  
bit 15-0     **DMTIVT[31:16]:** DMT Window Interval Higher 16 bits

# dsPIC33CK256MP508 FAMILY

## REGISTER 30-11: FDMTCNTL CONFIGURATION REGISTER

U-1	U-1	U-1	U-1	U-1	U-1	U-1	U-1
—	—	—	—	—	—	—	—
bit 23							bit 16

R/PO-1	R/PO-1	R/PO-1	R/PO-1	R/PO-1	R/PO-1	R/PO-1	R/PO-1
DMTCNT[15:8]							
bit 15							bit 8

R/PO-1	R/PO-1	R/PO-1	R/PO-1	R/PO-1	R/PO-1	R/PO-1	R/PO-1
DMTCNT[7:0]							
bit 7							bit 0

<b>Legend:</b>	PO = Program Once bit		
R = Readable bit	W = Writable bit	U = Unimplemented bit, read as '0'	
-n = Value at POR	'1' = Bit is set	'0' = Bit is cleared	x = Bit is unknown

bit 23-16     **Unimplemented:** Read as '1'  
bit 15-0     **DMTCNT[15:0]:** DMT Instruction Count Time-out Value Lower 16 bits

## REGISTER 30-12: FDMTCNTH CONFIGURATION REGISTER

U-1	U-1	U-1	U-1	U-1	U-1	U-1	U-1
—	—	—	—	—	—	—	—
bit 23							bit 16

R/PO-1	R/PO-1	R/PO-1	R/PO-1	R/PO-1	R/PO-1	R/PO-1	R/PO-1
DMTCNT[31:24]							
bit 15							bit 8

R/PO-1	R/PO-1	R/PO-1	R/PO-1	R/PO-1	R/PO-1	R/PO-1	R/PO-1
DMTCNT[23:16]							
bit 7							bit 0

<b>Legend:</b>	PO = Program Once bit		
R = Readable bit	W = Writable bit	U = Unimplemented bit, read as '0'	
-n = Value at POR	'1' = Bit is set	'0' = Bit is cleared	x = Bit is unknown

bit 23-16     **Unimplemented:** Read as '1'  
bit 15-0     **DMTCNT[31:16]:** DMT Instruction Count Time-out Value Upper 16 bits

# dsPIC33CK256MP508 FAMILY

## REGISTER 30-13: FDMT CONFIGURATION REGISTER

U-1	U-1	U-1	U-1	U-1	U-1	U-1	U-1
—	—	—	—	—	—	—	—
bit 23							bit 16

U-1	U-1	U-1	U-1	U-1	U-1	U-1	U-1
—	—	—	—	—	—	—	—
bit 15							bit 8

U-1	U-1	U-1	U-1	U-1	U-1	U-1	R/PO-1
—	—	—	—	—	—	—	DMTDIS
bit 7							bit 0

<b>Legend:</b>	PO = Program Once bit
R = Readable bit	W = Writable bit
-n = Value at POR	'1' = Bit is set
	'0' = Bit is cleared
	x = Bit is unknown
	U = Unimplemented bit, read as '0'

bit 23-1 **Unimplemented:** Read as '1'

bit 0 **DMTDIS:** DMT Disable bit

1 = DMT is disabled and can be enabled by software using the ON bit (DMTCON[15])

0 = DMT is enabled and cannot be disabled by software

# dsPIC33CK256MP508 FAMILY

## REGISTER 30-14: FDEVOPT CONFIGURATION REGISTER

U-1	U-1	U-1	U-1	U-1	U-1	U-1	U-1
—	—	—	—	—	—	—	—
bit 23							bit 16

U-1	U-1	R/PO-1	U-1	U-1	R/PO-1	r-0	r-0
—	—	SPI2PIN <sup>(1)</sup>	—	—	SMBEN	—	—
bit 15							bit 8

r-1	U-1	R/PO-1	R/PO-1	R/PO-1	r-1	U-1	U-1
—	—	ALT12C3	ALT12C2	ALT12C1	—	—	—
bit 7							bit 0

<b>Legend:</b>	PO = Program Once bit	r = Reserved bit
R = Readable bit	W = Writable bit	U = Unimplemented bit, read as '0'
-n = Value at POR	'1' = Bit is set	'0' = Bit is cleared
		x = Bit is unknown

- bit 23-14 **Unimplemented:** Read as '1'
- bit 13 **SPI2PIN:** Host SPI #2 Fast I/O Pad Disable bit<sup>(1)</sup>
  - 1 = Host SPI2 uses PPS (I/O remap) to make connections with device pins
  - 0 = Host SPI2 uses direct connections with specified device pins
- bit 12-11 **Unimplemented:** Read as '1'
- bit 10 **SMBEN:** Select Input Voltage Threshold for I<sup>2</sup>C Pads to be SMBus 3.0 Compliant bit
  - 1 = Enables SMBus 3.0 input threshold voltage
  - 0 = I<sup>2</sup>C pad input buffer operation
- bit 9-8 **Reserved:** Maintain as '0'
- bit 7 **Reserved:** Maintain as '1'
- bit 6 **Unimplemented:** Read as '1'
- bit 5 **ALT12C3:** Alternate I2C3 Pin Mapping bit
  - 1 = Default location for SCL3/SDA3 pins
  - 0 = Alternate location for SCL3/SDA3 pins (ASCL3/ASDA3)
- bit 4 **ALT12C2:** Alternate I2C2 Pin Mapping bit
  - 1 = Default location for SCL2/SDA2 pins
  - 0 = Alternate location for SCL2/SDA2 pins (ASCL2/ASDA2)
- bit 3 **ALT12C1:** Alternate I2C1 Pin Mapping bit
  - 1 = Default location for SCL1/SDA1 pins
  - 0 = Alternate location for SCL1/SDA1 pins (ASCL1/ASDA1)
- bit 2 **Reserved:** Maintain as '1'
- bit 1-0 **Unimplemented:** Read as '1'

**Note 1:** Fixed pin option is only available for higher pin packages (48-pin, 64-pin and 80-pin).



# dsPIC33CK256MP508 FAMILY

## REGISTER 30-15: FALTREG CONFIGURATION REGISTER

U-1	U-1	U-1	U-1	U-1	U-1	U-1	U-1
—	—	—	—	—	—	—	—
bit 23						bit 16	

U-1	R/PO-1	R/PO-1	R/PO-1	U-1	R/PO-1	R/PO-1	R/PO-1
—	CTXT4[2:0]			—	CTXT3[2:0]		
bit 15						bit 8	

U-1	R/PO-1	R/PO-1	R/PO-1	U-1	R/PO-1	R/PO-1	R/PO-1
—	CTXT2[2:0]			—	CTXT1[2:0]		
bit 7						bit 0	

<b>Legend:</b>	PO = Program Once bit
R = Readable bit	W = Writable bit
-n = Value at POR	'1' = Bit is set
	'0' = Bit is cleared
	x = Bit is unknown
	U = Unimplemented bit, read as '0'

bit 23-15 **Unimplemented:** Read as '1'

bit 14-12 **CTXT4[2:0]:** Specifies the Alternate Working Register Set #4 with Interrupt Priority Levels (IPL) bits  
 111 = Not assigned  
 110 = Alternate Register Set #4 is assigned to IPL Level 7  
 101 = Alternate Register Set #4 is assigned to IPL Level 6  
 100 = Alternate Register Set #4 is assigned to IPL Level 5  
 011 = Alternate Register Set #4 is assigned to IPL Level 4  
 010 = Alternate Register Set #4 is assigned to IPL Level 3  
 001 = Alternate Register Set #4 is assigned to IPL Level 2  
 000 = Alternate Register Set #4 is assigned to IPL Level 1

bit 11 **Unimplemented:** Read as '1'

bit 10-8 **CTXT3[2:0]:** Specifies the Alternate Working Register Set #3 with Interrupt Priority Levels (IPL) bits  
 111 = Not assigned  
 110 = Alternate Register Set #3 is assigned to IPL Level 7  
 101 = Alternate Register Set #3 is assigned to IPL Level 6  
 100 = Alternate Register Set #3 is assigned to IPL Level 5  
 011 = Alternate Register Set #3 is assigned to IPL Level 4  
 010 = Alternate Register Set #3 is assigned to IPL Level 3  
 001 = Alternate Register Set #3 is assigned to IPL Level 2  
 000 = Alternate Register Set #3 is assigned to IPL Level 1

bit 7 **Unimplemented:** Read as '1'

bit 6-4 **CTXT2[2:0]:** Specifies the Alternate Working Register Set #2 with Interrupt Priority Levels (IPL) bits  
 111 = Not assigned  
 110 = Alternate Register Set #2 is assigned to IPL Level 7  
 101 = Alternate Register Set #2 is assigned to IPL Level 6  
 100 = Alternate Register Set #2 is assigned to IPL Level 5  
 011 = Alternate Register Set #2 is assigned to IPL Level 4  
 010 = Alternate Register Set #2 is assigned to IPL Level 3  
 001 = Alternate Register Set #2 is assigned to IPL Level 2  
 000 = Alternate Register Set #2 is assigned to IPL Level 1

bit 3 **Unimplemented:** Read as '1'

# dsPIC33CK256MP508 FAMILY

## REGISTER 30-15: FALTREG CONFIGURATION REGISTER (CONTINUED)

bit 2-0      **CTX1[2:0]:** Specifies the Alternate Working Register Set #1 with Interrupt Priority Levels (IPL) bits

111 = Not assigned  
 110 = Alternate Register Set #1 is assigned to IPL Level 7  
 101 = Alternate Register Set #1 is assigned to IPL Level 6  
 100 = Alternate Register Set #1 is assigned to IPL Level 5  
 011 = Alternate Register Set #1 is assigned to IPL Level 4  
 010 = Alternate Register Set #1 is assigned to IPL Level 3  
 001 = Alternate Register Set #1 is assigned to IPL Level 2  
 000 = Alternate Register Set #1 is assigned to IPL Level 1

## REGISTER 30-16: FBTSEQ CONFIGURATION REGISTER

R/PO-1	R/PO-1	R/PO-1	R/PO-1	R/PO-1	R/PO-1	R/PO-1	R/PO-1
IBSEQ[11:4]							
bit 23				bit 16			

R/PO-1	R/PO-1	R/PO-1	R/PO-1	R/PO-1	R/PO-1	R/PO-1	R/PO-1
IBSEQ[3:0]				BSEQ[11:8]			
bit 15				bit 8			

R/PO-1	R/PO-1	R/PO-1	R/PO-1	R/PO-1	R/PO-1	R/PO-1	R/PO-1
BSEQ[7:0]							
bit 7				bit 0			

<b>Legend:</b>	PO = Program Once bit		
R = Readable bit	W = Writable bit	U = Unimplemented bit, read as '1'	
-n = Value at POR	'1' = Bit is set	'0' = Bit is cleared	x = Bit is unknown

bit 23-12      **IBSEQ[11:0]:** Inverse Boot Sequence Number bits (Dual Partition modes only)  
 The one's complement of BSEQ[11:0]; must be calculated by the user and written into device programming.

bit 11-0      **BSEQ[11:0]:** Boot Sequence Number bits (Dual Partition modes only)  
 Relative value defining which partition will be active after a device Reset; the partition containing a lower boot number will be active.

# dsPIC33CK256MP508 FAMILY

## REGISTER 30-17: FBOOT CONFIGURATION REGISTER

U-1	U-1	U-1	U-1	U-1	U-1	U-1	U-1
—	—	—	—	—	—	—	—
bit 15						bit 8	

U-1	U-1	U-1	U-1	U-1	U-1	R/PO-1	R/PO-1
—	—	—	—	—	—	BTMODE[1:0]	
bit 7						bit 0	

<b>Legend:</b>	PO = Program Once bit
R = Readable bit	W = Writable bit
-n = Value at POR	'1' = Bit is set
	'0' = Bit is cleared
	x = Bit is unknown
	U = Unimplemented bit, read as '1'

- bit 15-2     **Unimplemented:** Read as '1'
- bit 1-0     **BTMODE[1:0]:** Device Partition Mode Configuration Status bits
  - 11 = Single Partition mode
  - 10 = Dual Partition mode
  - 01 = Protected Dual Partition mode (Partition 1 is write-protected when inactive)
  - 00 = Reserved; do not use

# dsPIC33CK256MP508 FAMILY

## 30.2 Device Calibration and Identification

The dsPIC33CK256MP508 devices have two Identification registers, near the end of configuration memory space, that store the Device ID (DEVID) and Device

Revision (DEVREV). These registers are used to determine the mask, variant and manufacturing information about the device. These registers are read-only and are shown in [Register 30-18](#) and [Register 30-19](#).

### REGISTER 30-18: DEVREV: DEVICE REVISION REGISTER

U-1	U-1	U-1	U-1	U-1	U-1	U-1	U-1
—	—	—	—	—	—	—	—
bit 23							bit 16

r-0	U-1	U-1	U-1	U-1	U-1	U-1	U-1
—	—	—	—	—	—	—	—
bit 15							bit 8

U-1	U-1	U-1	U-1	R	R	R	R
—	—	—	—	DEVREV[3:0]			
bit 7				bit 0			

**Legend:** R = Read-only bit      r = Reserved bit      U = Unimplemented bit

- bit 23-16      **Unimplemented:** Read as '1'
- bit 15        **Reserved:** Maintain as '0'
- bit 14-4      **Unimplemented:** Read as '1'
- bit 3-0       **DEVREV[3:0]:** Device Revision bits

### REGISTER 30-19: DEVID: DEVICE ID REGISTERS

U-1	U-1	U-1	U-1	U-1	U-1	U-1	U-1
—	—	—	—	—	—	—	—
bit 23							bit 16

R	R	R	R	R	R	R	R
FAMID[7:0]							
bit 15							bit 8

R	R	R	R	R	R	R	R
DEV[7:0] <sup>(1)</sup>							
bit 7							bit 0

**Legend:** R = Read-only bit      U = Unimplemented bit

- bit 23-16      **Unimplemented:** Read as '1'
- bit 15-8       **FAMID[7:0]:** Device Family Identifier bits  
0111 1100 = dsPIC33CK256MP508 family
- bit 7-0        **DEV[7:0]:** Individual Device Identifier bits<sup>(1)</sup>

**Note 1:** See [Table 30-4](#) for the list of Device Identifier bits.

# dsPIC33CK256MP508 FAMILY

**TABLE 30-4: DEVICE IDs FOR THE dsPIC33CK256MP508 FAMILY**

Device	DEVID
<b>Device IDs for dsPIC33CK256MP508 Family with CAN FD</b>	
dsPIC33CK256MP508	0x7C74
dsPIC33CK256MP506	0x7C73
dsPIC33CK256MP505	0x7C72
dsPIC33CK256MP503	0x7C71
dsPIC33CK256MP502	0x7C70
dsPIC33CK128MP508	0x7C64
dsPIC33CK128MP506	0x7C63
dsPIC33CK128MP505	0x7C62
dsPIC33CK128MP503	0x7C61
dsPIC33CK128MP502	0x7C60
dsPIC33CK64MP508	0x7C54
dsPIC33CK64MP506	0x7C53
dsPIC33CK64MP505	0x7C52
dsPIC33CK64MP503	0x7C51
dsPIC33CK64MP502	0x7C50
dsPIC33CK32MP506	0x7C43
dsPIC33CK32MP505	0x7C42
dsPIC33CK32MP503	0x7C41
dsPIC33CK32MP502	0x7C40
<b>Device IDs for dsPIC33CK256MP508 Family without CAN FD</b>	
dsPIC33CK256MP208	0x7C34
dsPIC33CK256MP206	0x7C33
dsPIC33CK256MP205	0x7C32
dsPIC33CK256MP203	0x7C31
dsPIC33CK256MP202	0x7C30
dsPIC33CK128MP208	0x7C24
dsPIC33CK128MP206	0x7C23
dsPIC33CK128MP205	0x7C22
dsPIC33CK128MP203	0x7C21
dsPIC33CK128MP202	0x7C20
dsPIC33CK64MP208	0x7C14
dsPIC33CK64MP206	0x7C13
dsPIC33CK64MP205	0x7C12
dsPIC33CK64MP203	0x7C11
dsPIC33CK64MP202	0x7C10
dsPIC33CK32MP206	0x7C03
dsPIC33CK32MP205	0x7C02
dsPIC33CK32MP203	0x7C01
dsPIC33CK32MP202	0x7C00

# dsPIC33CK256MP508 FAMILY

---

## 30.3 User OTP Memory

The dsPIC33CK256MP508 family devices contain 64 One-Time-Programmable (OTP) double words, located at addresses, 801700h through 8017FEh. Each 48-bit OTP double word can only be written one time. The OTP Words can be used for storing checksums, code revisions, manufacturing dates, manufacturing lot numbers or any other application-specific information.

The OTP area is not cleared by any erase command. This memory can be written only once.

## 30.4 On-Chip Voltage Regulators

The dsPIC33CK256MP508 family devices have a capacitorless internal voltage regulator to supply power to the core at 1.2V (typical).

The regulators have Low-Power and Standby modes for use in Sleep modes. For additional information about Sleep, see [Section 29.2.1 “Sleep Mode”](#).

When the regulators are in Low-Power mode (LPWREN = 1), the power available to the core is limited. Before the LPWREN bit is set, the device should be placed into a lower power state by disabling peripherals and lowering CPU frequency (e.g., 8 MHz FRC without PLL).

# dsPIC33CK256MP508 FAMILY

## REGISTER 30-20: VREGCON: VOLTAGE REGULATOR CONTROL REGISTER<sup>(1)</sup>

R/W-0	U-0	U-0	U-0	U-0	U-0	U-0	U-0
LPWREN <sup>(2)</sup>	—	—	—	—	—	—	—
bit 15							bit 8

U-0	U-0	r-0	r-0	r-0	r-0	r-0	r-0
—	—	—	—	—	—	—	—
bit 7							bit 0

<b>Legend:</b>	r = Reserved bit	U = Unimplemented bit, read as '0'
R = Readable bit	W = Writable bit	'0' = Bit is cleared
-n = Value at POR	'1' = Bit is set	x = Bit is unknown

bit 15      **LPWREN:** Low-Power Mode Enable bit<sup>(2)</sup>  
 1 = Voltage regulators are in Low-Power mode  
 0 = Voltage regulators are in Full-Power mode

bit 14-6      **Unimplemented:** Read as '0'

bit 5-0      **Reserved:** Maintain as '0'

**Note 1:** Hardware resets this register only on a POR Reset.

**2:** Low-Power mode can only be used within the industrial temperature range. The CPU should be run at slow speed (8 MHz or less) before setting this bit.

### 30.5 Brown-out Reset (BOR)

The Brown-out Reset (BOR) module is based on an internal voltage reference circuit that monitors the regulated supply voltage. The main purpose of the BOR module is to generate a device Reset when a brown-out condition occurs. Brown-out conditions are generally caused by glitches on the AC mains (for example, missing portions of the AC cycle waveform due to bad power transmission lines or voltage sags due to excessive current draw when a large inductive load is turned on).

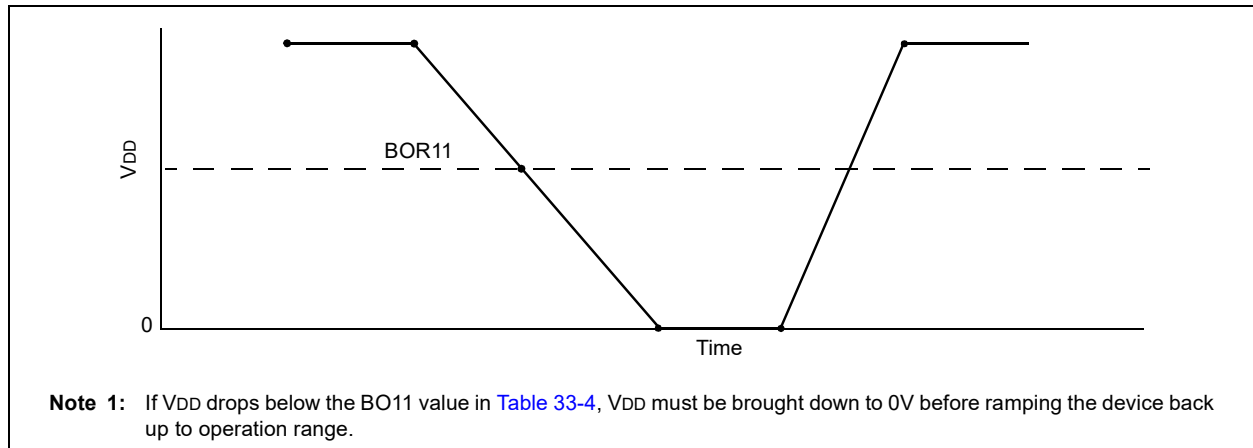
A BOR generates a Reset pulse which resets the device. The BOR selects the clock source based on the device Configuration bit selections.

If an Oscillator mode is selected, the BOR activates the Oscillator Start-up Timer (OST). The system clock is held until OST expires. If the PLL is used, the clock is held until the LOCK bit (OSCCON[5]) is '1'.

The BOR status bit (RCON[1]) is set to indicate that a BOR has occurred. The BOR circuit continues to operate while in Sleep or Idle mode and resets the device should VDD fall below the BOR threshold voltage.

If VDD drops below the BO11 value in [Figure 30-1](#), VDD must be brought down to 0V before ramping the device back up to operation range.

**FIGURE 30-1: POR EVENT ON VDD**



# dsPIC33CK256MP508 FAMILY

## 30.6 Dual Watchdog Timer (WDT)

**Note 1:** This data sheet summarizes the features of the dsPIC33CK256MP508 family of devices. It is not intended to be a comprehensive reference source. To complement the information in this data sheet, refer to “Dual Watchdog Timer”, (DS70005250) in the “dsPIC33/PIC24 Family Reference Manual”, which is available from the Microchip website ([www.microchip.com](http://www.microchip.com)).

The dsPIC33 dual Watchdog Timer (WDT) is described in this section. Refer to Figure 30-2 for a block diagram of the WDT.

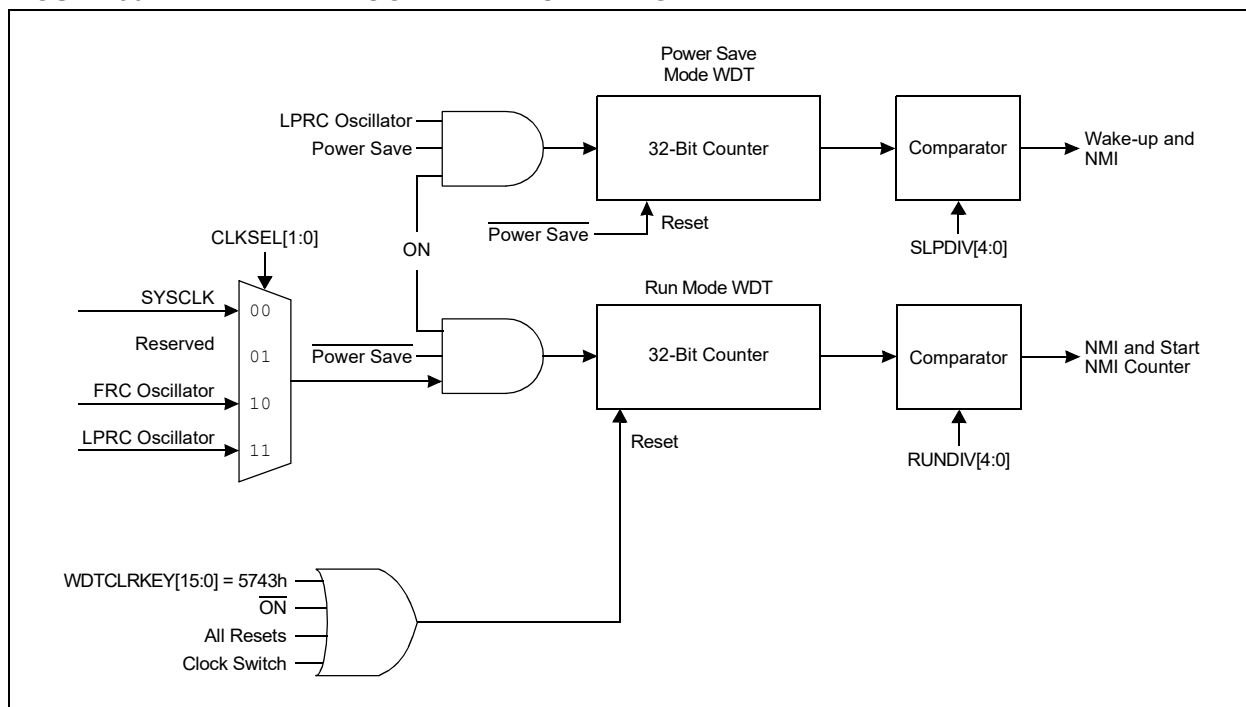
The WDT, when enabled, operates from the internal Low-Power RC (LPRC) Oscillator clock source or a selectable clock source in Run mode. The WDT can be used to detect system software malfunctions by reset-

ting the device if the WDT is not cleared periodically in software. The WDT can be configured in Windowed mode or Non-Windowed mode. Various WDT time-out periods can be selected using the WDT postscaler. The WDT can also be used to wake the device from Sleep or Idle mode (Power Save mode). If the WDT expires and issues a device Reset, the WTDO bit in RCON (Register 6-1) will be set. It is recommended to have at least two WDT clock cycles of delay after a CLRWDT instruction, in case one needs to perform a PWRSAV/NVM operation soon after the CLRWDT instruction.

The following are some of the key features of the WDT module:

- Configuration or Software Controlled
- Separate User-Configurable Time-out Periods for Run and Sleep/Idle
- Can Wake the Device from Sleep or Idle
- User-Selectable Clock Source in Run mode
- Operates from LPRC in Sleep/Idle mode

**FIGURE 30-2: WATCHDOG TIMER BLOCK DIAGRAM**





# dsPIC33CK256MP508 FAMILY

## REGISTER 30-21: WDTCONL: WATCHDOG TIMER CONTROL REGISTER LOW

R/W-0	U-0	U-0	R-y	R-y	R-y	R-y	R-y
ON <sup>(1,2)</sup>	—	—	RUNDIV4 <sup>(3)</sup>	RUNDIV3 <sup>(3)</sup>	RUNDIV2 <sup>(3)</sup>	RUNDIV1 <sup>(3)</sup>	RUNDIV0 <sup>(3)</sup>
bit 15							bit 8

R	R	R-y	R-y	R-y	R-y	R-y	HS/R/W-0
CLKSEL1 <sup>(3,5)</sup>	CLKSEL0 <sup>(3,5)</sup>	SLPDIV4 <sup>(3)</sup>	SLPDIV3 <sup>(3)</sup>	SLPDIV2 <sup>(3)</sup>	SLPDIV1 <sup>(3)</sup>	SLPDIV0 <sup>(3)</sup>	WDTWINEN <sup>(4)</sup>
bit 7							bit 0

<b>Legend:</b>	HS = Hardware Settable bit	y = Value from Configuration bit on POR
R = Readable bit	W = Writable bit	U = Unimplemented bit, read as '0'
-n = Value at POR	'1' = Bit is set	'0' = Bit is cleared
		x = Bit is unknown

- bit 15      **ON:** Watchdog Timer Enable bit<sup>(1,2)</sup>  
 1 = Enables the Watchdog Timer if it is not enabled by the device configuration  
 0 = Disables the Watchdog Timer if it was enabled in software
- bit 14-13    **Unimplemented:** Read as '0'
- bit 12-8    **RUNDIV[4:0]:** WDT Run Mode Postscaler Status bits<sup>(3)</sup>  
 11111 = Divide by  $2^{31} = 2,147,483,648$   
 11110 = Divide by  $2^{30} = 1,073,741,824$   
 ...  
 00001 = Divide by  $2^{1, 2}$   
 00000 = Divide by  $2^{0, 1}$
- bit 7-6     **CLKSEL[1:0]:** WDT Run Mode Clock Select Status bits<sup>(3,5)</sup>  
 11 = LPRC Oscillator  
 10 = FRC Oscillator  
 01 = Reserved  
 00 = SYSCLK
- bit 5-1     **SLPDIV[4:0]:** Sleep and Idle Mode WDT Postscaler Status bits<sup>(3)</sup>  
 11111 = Divide by  $2^{31} = 2,147,483,648$   
 11110 = Divide by  $2^{30} = 1,073,741,824$   
 ...  
 00001 = Divide by  $2^{1, 2}$   
 00000 = Divide by  $2^{0, 1}$
- bit 0        **WDTWINEN:** Watchdog Timer Window Enable bit<sup>(4)</sup>  
 1 = Enables Window mode  
 0 = Disables Window mode

- Note 1:** A read of this bit will result in a '1' if the WDT is enabled by the device configuration or by software.
- 2:** The user's software should not read or write the peripheral's SFRs in the SYSCLK cycle immediately following the instruction that clears the module's ON bit.
- 3:** These bits reflect the value of the Configuration bits.
- 4:** The WDTWINEN bit reflects the status of the Configuration bit if the bit is set. If the bit is cleared, the value is controlled by software.
- 5:** The available clock sources are device-dependent.

# dsPIC33CK256MP508 FAMILY

---

---

## REGISTER 30-22: WDTCONH: WATCHDOG TIMER CONTROL REGISTER HIGH

W-0	W-0	W-0	W-0	W-0	W-0	W-0	W-0
WDTCLRKEY[15:8]							
bit 15							bit 8

W-0	W-0	W-0	W-0	W-0	W-0	W-0	W-0
WDTCLRKEY[7:0]							
bit 7							bit 0

### Legend:

R = Readable bit

W = Writable bit

U = Unimplemented bit, read as '0'

-n = Value at POR

'1' = Bit is set

'0' = Bit is cleared

x = Bit is unknown

bit 15-0

**WDTCLRKEY[15:0]:** Watchdog Timer Clear Key bits

To clear the Watchdog Timer to prevent a time-out, software must write the value, 0x5743, to this location using a single 16-bit write.

# dsPIC33CK256MP508 FAMILY

## 30.7 JTAG Interface

The dsPIC33CK256MP508 family devices implement a JTAG interface, which supports boundary scan device testing. Programming is not supported through the JTAG interface; only boundary scan is supported.

**Note:** Refer to “Programming and Diagnostics” (DS70608) in the “dsPIC33/PIC24 Family Reference Manual” for further information on usage, configuration and operation of the JTAG interface.

## 30.8 In-Circuit Serial Programming™ (ICSP™)

The dsPIC33CK256MP508 family devices can be serially programmed while in the end application circuit. This is done with two lines for clock and data, and three other lines for power, ground and the programming sequence. Serial programming allows customers to manufacture boards with unprogrammed devices and then program the device just before shipping the product. Serial programming also allows the most recent firmware or a custom firmware to be programmed. Refer to the “dsPIC33CK256MP508 Family Flash Programming Specification” (DS70005300) for details about In-Circuit Serial Programming (ICSP).

Any of the three pairs of programming clock/data pins can be used:

- PGC1 and PGD1
- PGC2 and PGD2
- PGC3 and PGD3

## 30.9 In-Circuit Debugger

When MPLAB® ICD 3 or the REAL ICE™ emulator is selected as a debugger, the in-circuit debugging functionality is enabled. This function allows simple debugging functions when used with MPLAB IDE. Debugging functionality is controlled through the PGCx (Emulation/Debug Clock) and PGDx (Emulation/Debug Data) pin functions.

Any of the three pairs of debugging clock/data pins can be used:

- PGC1 and PGD1
- PGC2 and PGD2
- PGC3 and PGD3

To use the in-circuit debugger function of the device, the design must implement ICSP connections to MCLR, VDD, VSS and the PGCx/PGDx pin pair. In addition, when the feature is enabled, some of the resources are not available for general use. These resources include the first 80 bytes of data RAM and two I/O pins (PGCx and PGDx).

## 30.10 Code Protection and CodeGuard™ Security

dsPIC33CK256MP508 family devices offer multiple levels of security for protecting individual intellectual property. The program Flash protection can be broken up into three segments: Boot Segment (BS), General Segment (GS) and Configuration Segment (CS). Boot Segment has the highest security privilege and can be thought to have limited restrictions when accessing other segments. General Segment has the least security and is intended for the end user system code. Configuration Segment contains only the device user configuration data, which are located at the end of the program memory space.

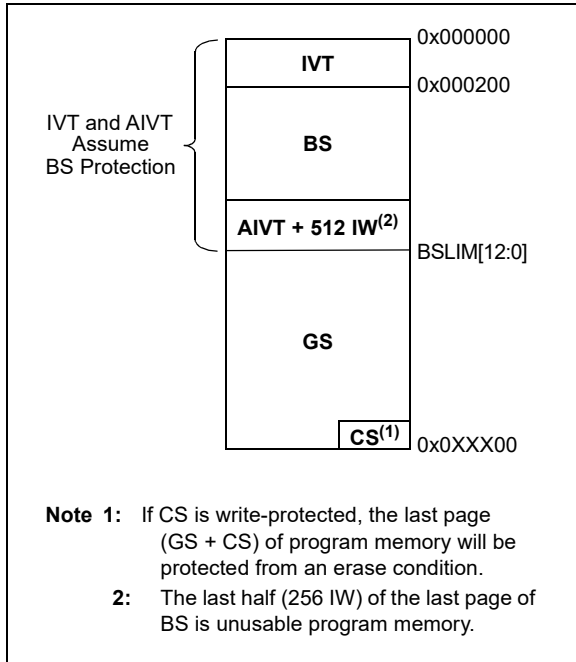
The code protection features are controlled by the Configuration registers, FSEC and FBSLIM. The FSEC register controls the code-protect level for each segment and if that segment is write-protected. The size of BS and GS will depend on the BSLIM[12:0] bits setting and if the Alternate Interrupt Vector Table (AIVT) is enabled. The BSLIM[12:0] bits define the number of pages for BS with each page containing 1024 IW. The smallest BS size is one page, which will consist of the Interrupt Vector Table (IVT) and 512 IW of code protection.

If the AIVT is enabled, the last page of BS will contain the AIVT and will not contain any BS code. With AIVT enabled, the smallest BS size is now two pages (2048 IW), with one page for the IVT and BS code, and the other page for the AIVT. Write protection of the BS does not cover the AIVT. The last page of BS can always be programmed or erased by BS code. The General Segment will start at the next page and will consume the rest of program Flash, except for the Flash Configuration Words. The IVT will assume GS security only if BS is not enabled. The IVT is protected from being programmed or page erased when either security segment has enabled write protection.

# dsPIC33CK256MP508 FAMILY

The different device security segments are shown in Figure 30-3. Here, all three segments are shown, but are not required. If only basic code protection is required, then GS can be enabled independently or combined with CS, if desired.

**FIGURE 30-3: SECURITY SEGMENTS EXAMPLE**

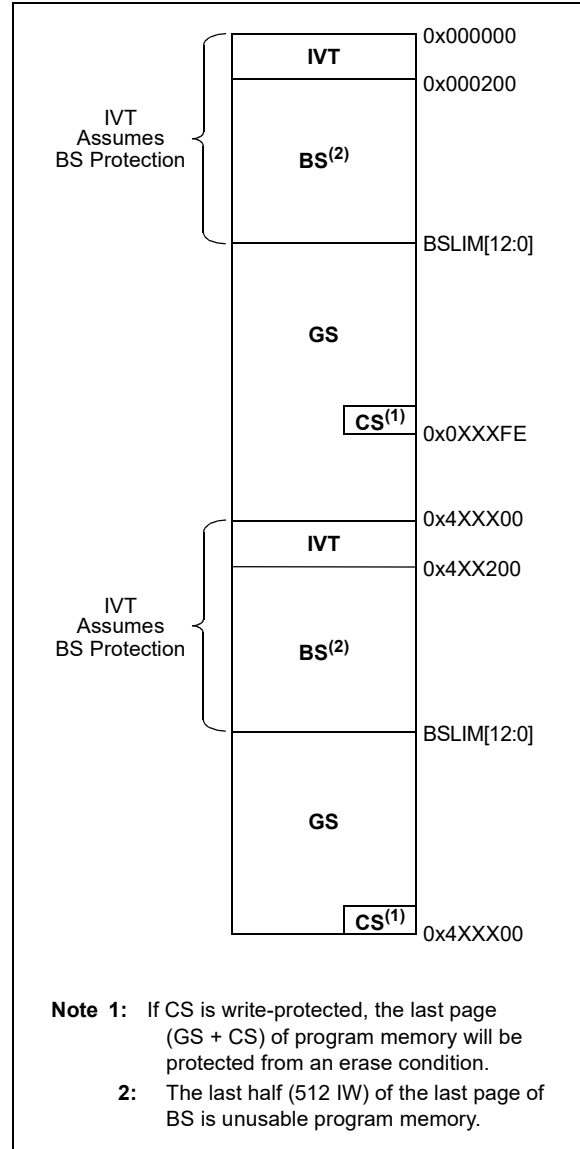


The dsPIC33CK256MP508 family can be operated in Dual Partition mode, where security is required for each partition. When operating in Dual Partition mode, the Active and Inactive Partitions both contain unique copies of the Reset vector and Interrupt Vector Tables (IVT, if enabled). Both partitions have the three security segments described previously. Code may not be executed from the Inactive Partition, but it may be programmed by, and read from, the Active Partition, subject to defined code protection. Figure 30-4 shows the different security segments for a device operating in Dual Partition mode.

The device may also operate in a Protected Dual Partition mode or in Privileged Dual Partition mode. In Protected Dual Partition mode, Partition 1 is permanently erase/write-protected. This implementation allows for a "Factory Default" mode, which provides a fail-safe backup image to be stored in Partition 1. For example, a fail-safe bootloader can be placed in Partition 1, along with a fail-safe backup code image, which can be used or rewritten into Partition 2 in the event of a failed Flash update to Partition 2.

Privileged Dual Partition mode performs the same function as Protected Dual Partition mode, except additional constraints are applied in an effort to prevent code in the Boot Segment and General Segment from being used against each other.

**FIGURE 30-4: SECURITY SEGMENTS EXAMPLE (DUAL PARTITION MODES)**



## 31.0 INSTRUCTION SET SUMMARY

**Note:** This data sheet summarizes the features of the dsPIC33CK256MP508 family of devices. It is not intended to be a comprehensive reference source. To complement the information in this data sheet, refer to the “16-Bit MCU and DSC Programmer’s Reference Manual” ([www.microchip.com/DS70000157](http://www.microchip.com/DS70000157)), which is available from the Microchip website.

The dsPIC33CK256MP508 family instruction set is almost identical to that of the dsPIC30F and dsPIC33F.

Most instructions are a single program memory word (24 bits). Only three instructions require two program memory locations.

Each single-word instruction is a 24-bit word, divided into an 8-bit opcode, which specifies the instruction type and one or more operands, which further specify the operation of the instruction.

The instruction set is highly orthogonal and is grouped into five basic categories:

- Word or byte-oriented operations
- Bit-oriented operations
- Literal operations
- DSP operations
- Control operations

Table 31-1 lists the general symbols used in describing the instructions.

The dsPIC33 instruction set summary in Table 31-2 lists all the instructions, along with the status flags affected by each instruction.

Most word or byte-oriented W register instructions (including barrel shift instructions) have three operands:

- The first source operand, which is typically a register ‘Wb’ without any address modifier
- The second source operand, which is typically a register ‘Ws’ with or without an address modifier
- The destination of the result, which is typically a register ‘Wd’ with or without an address modifier

However, word or byte-oriented file register instructions have two operands:

- The file register specified by the value ‘f’
- The destination, which could be either the file register ‘f’ or the W0 register, which is denoted as ‘WREG’

Most bit-oriented instructions (including simple rotate/shift instructions) have two operands:

- The W register (with or without an address modifier) or file register (specified by the value of ‘Ws’ or ‘f’)
- The bit in the W register or file register (specified by a literal value or indirectly by the contents of register ‘Wb’)

The literal instructions that involve data movement can use some of the following operands:

- A literal value to be loaded into a W register or file register (specified by ‘k’)
- The W register or file register where the literal value is to be loaded (specified by ‘Wb’ or ‘f’)

However, literal instructions that involve arithmetic or logical operations use some of the following operands:

- The first source operand, which is a register ‘Wb’ without any address modifier
- The second source operand, which is a literal value
- The destination of the result (only if not the same as the first source operand), which is typically a register ‘Wd’ with or without an address modifier

The MAC class of DSP instructions can use some of the following operands:

- The accumulator (A or B) to be used (required operand)
- The W registers to be used as the two operands
- The X and Y address space prefetch operations
- The X and Y address space prefetch destinations
- The accumulator write-back destination

The other DSP instructions do not involve any multiplication and can include:

- The accumulator to be used (required)
- The source or destination operand (designated as Wso or Wdo, respectively) with or without an address modifier
- The amount of shift specified by a W register ‘Wn’ or a literal value

The control instructions can use some of the following operands:

- A program memory address
- The mode of the Table Read and Table Write instructions

# dsPIC33CK256MP508 FAMILY

Most instructions are a single word. Certain double-word instructions are designed to provide all the required information in these 48 bits. In the second word, the eight MSBs are '0's. If this second word is executed as an instruction (by itself), it executes as a NOP.

The double-word instructions execute in two instruction cycles.

Most single-word instructions are executed in a single instruction cycle, unless a conditional test is true or the Program Counter is changed as a result of the instruction, or a PSV or Table Read is performed. In these cases, the execution takes multiple instruction cycles, with the additional instruction cycle(s) executed as a NOP. Certain instructions that involve skipping over the subsequent instruction require either two or three

cycles if the skip is performed, depending on whether the instruction being skipped is a single-word or two-word instruction. Moreover, double-word moves require two cycles.

**Note:** In dsPIC33CK256MP508 devices, read and Read-Modify-Write operations on non-CPU Special Function Registers require an additional cycle when compared to dsPIC30F, dsPIC33F, PIC24F and PIC24H devices.

**Note:** For more details on the instruction set, refer to the "16-Bit MCU and DSC Programmer's Reference Manual" (DS70000157).

**TABLE 31-1: SYMBOLS USED IN OPCODE DESCRIPTIONS**

Field	Description
#text	Means literal defined by "text"
(text)	Means "content of text"
[text]	Means "the location addressed by text"
{ }	Optional field or operation
a ∈ {b, c, d}	a is selected from the set of values b, c, d
[n:m]	Register bit field
.b	Byte mode selection
.d	Double-Word mode selection
.S	Shadow register select
.w	Word mode selection (default)
Acc	One of two accumulators {A, B}
AWB	Accumulator Write-Back Destination Address register ∈ {W13, [W13]+ = 2}
bit4	4-bit bit selection field (used in word-addressed instructions) ∈ {0...15}
C, DC, N, OV, Z	MCU Status bits: Carry, Digit Carry, Negative, Overflow, Sticky Zero
Expr	Absolute address, label or expression (resolved by the linker)
f	File register address ∈ {0x0000...0x1FFF}
lit1	1-bit unsigned literal ∈ {0,1}
lit4	4-bit unsigned literal ∈ {0...15}
lit5	5-bit unsigned literal ∈ {0...31}
lit8	8-bit unsigned literal ∈ {0...255}
lit10	10-bit unsigned literal ∈ {0...255} for Byte mode, {0:1023} for Word mode
lit14	14-bit unsigned literal ∈ {0...16384}
lit16	16-bit unsigned literal ∈ {0...65535}
lit23	23-bit unsigned literal ∈ {0...8388608}; LSb must be '0'
None	Field does not require an entry, can be blank
OA, OB, SA, SB	DSP Status bits: ACCA Overflow, ACCB Overflow, ACCA Saturate, ACCB Saturate
PC	Program Counter
Slit10	10-bit signed literal ∈ {-512...511}
Slit16	16-bit signed literal ∈ {-32768...32767}
Slit6	6-bit signed literal ∈ {-16...16}
Wb	Base W register ∈ {W0...W15}
Wd	Destination W register ∈ { Wd, [Wd], [Wd++], [Wd--], [++Wd], [--Wd] }
Wdo	Destination W register ∈ { Wnd, [Wnd], [Wnd++], [Wnd--], [++Wnd], [--Wnd], [Wnd+Wb] }
Wm, Wn	Dividend, Divisor Working register pair (direct addressing)

# dsPIC33CK256MP508 FAMILY

**TABLE 31-1: SYMBOLS USED IN OPCODE DESCRIPTIONS (CONTINUED)**

Field	Description
Wm*Wm	Multiplicand and Multiplier Working register pair for Square instructions $\in$ {W4 * W4, W5 * W5, W6 * W6, W7 * W7}
Wm*Wn	Multiplicand and Multiplier Working register pair for DSP instructions $\in$ {W4 * W5, W4 * W6, W4 * W7, W5 * W6, W5 * W7, W6 * W7}
Wn	One of 16 Working registers $\in$ {W0...W15}
Wnd	One of 16 Destination Working registers $\in$ {W0...W15}
Wns	One of 16 Source Working registers $\in$ {W0...W15}
WREG	W0 (Working register used in file register instructions)
Ws	Source W register $\in$ { Ws, [Ws], [Ws++], [Ws--], [++Ws], [--Ws] }
Wso	Source W register $\in$ { Wns, [Wns], [Wns++], [Wns--], [++Wns], [--Wns], [Wns+Wb] }
Wx	X Data Space Prefetch Address register for DSP instructions $\in$ {[W8] + = 6, [W8] + = 4, [W8] + = 2, [W8], [W8] - = 6, [W8] - = 4, [W8] - = 2, [W9] + = 6, [W9] + = 4, [W9] + = 2, [W9], [W9] - = 6, [W9] - = 4, [W9] - = 2, [W9 + W12], none}
Wxd	X Data Space Prefetch Destination register for DSP instructions $\in$ {W4...W7}
Wy	Y Data Space Prefetch Address register for DSP instructions $\in$ {[W10] + = 6, [W10] + = 4, [W10] + = 2, [W10], [W10] - = 6, [W10] - = 4, [W10] - = 2, [W11] + = 6, [W11] + = 4, [W11] + = 2, [W11], [W11] - = 6, [W11] - = 4, [W11] - = 2, [W11 + W12], none}
Wyd	Y Data Space Prefetch Destination register for DSP instructions $\in$ {W4...W7}

# dsPIC33CK256MP508 FAMILY

**TABLE 31-2: INSTRUCTION SET OVERVIEW**

Base Instr #	Assembly Mnemonic	Assembly Syntax	Description	# of Words	# of Cycles <sup>(1)</sup>	Status Flags Affected
1	ADD	ADD <i>Acc</i>	Add Accumulators	1	1	OA,OB,SA,SB
		ADD <i>f</i>	$f = f + WREG$	1	1	C,DC,N,OV,Z
		ADD <i>f, WREG</i>	$WREG = f + WREG$	1	1	C,DC,N,OV,Z
		ADD <i>#lit10, Wn</i>	$Wd = lit10 + Wd$	1	1	C,DC,N,OV,Z
		ADD <i>Wb, Ws, Wd</i>	$Wd = Wb + Ws$	1	1	C,DC,N,OV,Z
		ADD <i>Wb, #lit5, Wd</i>	$Wd = Wb + lit5$	1	1	C,DC,N,OV,Z
		ADD <i>Wso, #Slit4, Acc</i>	16-bit Signed Add to Accumulator	1	1	OA,OB,SA,SB
2	ADDC	ADDC <i>f</i>	$f = f + WREG + (C)$	1	1	C,DC,N,OV,Z
		ADDC <i>f, WREG</i>	$WREG = f + WREG + (C)$	1	1	C,DC,N,OV,Z
		ADDC <i>#lit10, Wn</i>	$Wd = lit10 + Wd + (C)$	1	1	C,DC,N,OV,Z
		ADDC <i>Wb, Ws, Wd</i>	$Wd = Wb + Ws + (C)$	1	1	C,DC,N,OV,Z
		ADDC <i>Wb, #lit5, Wd</i>	$Wd = Wb + lit5 + (C)$	1	1	C,DC,N,OV,Z
3	AND	AND <i>f</i>	$f = f .AND. WREG$	1	1	N,Z
		AND <i>f, WREG</i>	$WREG = f .AND. WREG$	1	1	N,Z
		AND <i>#lit10, Wn</i>	$Wd = lit10 .AND. Wd$	1	1	N,Z
		AND <i>Wb, Ws, Wd</i>	$Wd = Wb .AND. Ws$	1	1	N,Z
		AND <i>Wb, #lit5, Wd</i>	$Wd = Wb .AND. lit5$	1	1	N,Z
4	ASR	ASR <i>f</i>	$f = \text{Arithmetic Right Shift } f$	1	1	C,N,OV,Z
		ASR <i>f, WREG</i>	$WREG = \text{Arithmetic Right Shift } f$	1	1	C,N,OV,Z
		ASR <i>Ws, Wd</i>	$Wd = \text{Arithmetic Right Shift } Ws$	1	1	C,N,OV,Z
		ASR <i>Wb, Wns, Wnd</i>	$Wnd = \text{Arithmetic Right Shift } Wb \text{ by } Wns$	1	1	N,Z
		ASR <i>Wb, #lit5, Wnd</i>	$Wnd = \text{Arithmetic Right Shift } Wb \text{ by } lit5$	1	1	N,Z
5	BCLR	BCLR <i>f, #bit4</i>	Bit Clear <i>f</i>	1	1	None
		BCLR <i>Ws, #bit4</i>	Bit Clear <i>Ws</i>	1	1	None
6	BFEXT	BFEXT <i>bit4, wid5, Ws, Wb</i>	Bit Field Extract from <i>Ws</i> to <i>Wb</i>	2	2	None
		BFEXT <i>bit4, wid5, f, Wb</i>	Bit Field Extract from <i>f</i> to <i>Wb</i>	2	2	None
7	BFINS	BFINS <i>bit4, wid5, Wb, Ws</i>	Bit Field Insert from <i>Wb</i> into <i>Ws</i>	2	2	None
		BFINS <i>bit4, wid5, Wb, f</i>	Bit Field Insert from <i>Wb</i> into <i>f</i>	2	2	None
		BFINS <i>bit4, wid5, lit8, Ws</i>	Bit Field Insert from <i>#lit8</i> to <i>Ws</i>	2	2	None
8	BOOTSWP	BOOTSWP	Swap the Active and Inactive Program Flash Space	1	2	None

**Note 1:** Read and Read-Modify-Write (e.g., bit operations and logical operations) on non-CPU SFRs incur an additional instruction cycle.

**2:** The divide instructions must be preceded with a "REPEAT #5" instruction, such that they are executed six consecutive times.



# dsPIC33CK256MP508 FAMILY

**TABLE 31-2: INSTRUCTION SET OVERVIEW (CONTINUED)**

Base Instr #	Assembly Mnemonic	Assembly Syntax	Description	# of Words	# of Cycles <sup>(1)</sup>	Status Flags Affected
9	BRA	BRA C, Expr	Branch if Carry	1	1 (4)	None
		BRA GE, Expr	Branch if Greater Than or Equal	1	1 (4)	None
		BRA GEU, Expr	Branch if unsigned Greater Than or Equal	1	1 (4)	None
		BRA GT, Expr	Branch if Greater Than	1	1 (4)	None
		BRA GTU, Expr	Branch if Unsigned Greater Than	1	1 (4)	None
		BRA LE, Expr	Branch if Less Than or Equal	1	1 (4)	None
		BRA LEU, Expr	Branch if Unsigned Less Than or Equal	1	1 (4)	None
		BRA LT, Expr	Branch if Less Than	1	1 (4)	None
		BRA LTU, Expr	Branch if Unsigned Less Than	1	1 (4)	None
		BRA N, Expr	Branch if Negative	1	1 (4)	None
		BRA NC, Expr	Branch if Not Carry	1	1 (4)	None
		BRA NN, Expr	Branch if Not Negative	1	1 (4)	None
		BRA NOV, Expr	Branch if Not Overflow	1	1 (4)	None
		BRA NZ, Expr	Branch if Not Zero	1	1 (4)	None
		BRA OA, Expr	Branch if Accumulator A Overflow	1	1 (4)	None
		BRA OB, Expr	Branch if Accumulator B Overflow	1	1 (4)	None
		BRA OV, Expr	Branch if Overflow	1	1 (4)	None
		BRA SA, Expr	Branch if Accumulator A Saturated	1	1 (4)	None
		BRA SB, Expr	Branch if Accumulator B Saturated	1	1 (4)	None
		BRA Expr	Branch Unconditionally	1	4	None
BRA Z, Expr	Branch if Zero	1	1 (4)	None		
BRA Wn	Computed Branch	1	4	None		
10	BREAK	BREAK	Stop User Code Execution	1	1	None
11	BSET	BSET f, #bit4	Bit Set f	1	1	None
		BSET Ws, #bit4	Bit Set Ws	1	1	None
12	BSW	BSW.C Ws, Wb	Write C bit to Ws[Wb]	1	1	None
		BSW.Z Ws, Wb	Write Z bit to Ws[Wb]	1	1	None
13	BTG	BTG f, #bit4	Bit Toggle f	1	1	None
		BTG Ws, #bit4	Bit Toggle Ws	1	1	None
14	BTSC	BTSC f, #bit4	Bit Test f, Skip if Clear	1	1 (2 or 3)	None
		BTSC Ws, #bit4	Bit Test Ws, Skip if Clear	1	1 (2 or 3)	None
15	BTSS	BTSS f, #bit4	Bit Test f, Skip if Set	1	1 (2 or 3)	None
		BTSS Ws, #bit4	Bit Test Ws, Skip if Set	1	1 (2 or 3)	None
16	BTST	BTST f, #bit4	Bit Test f	1	1	Z
		BTST.C Ws, #bit4	Bit Test Ws to C	1	1	C
		BTST.Z Ws, #bit4	Bit Test Ws to Z	1	1	Z
		BTST.C Ws, Wb	Bit Test Ws[Wb] to C	1	1	C
		BTST.Z Ws, Wb	Bit Test Ws[Wb] to Z	1	1	Z
17	BTSTS	BTSTS f, #bit4	Bit Test then Set f	1	1	Z
		BTSTS.C Ws, #bit4	Bit Test Ws to C, then Set	1	1	C
		BTSTS.Z Ws, #bit4	Bit Test Ws to Z, then Set	1	1	Z
18	CALL	CALL lit23	Call Subroutine	2	4	SFA
		CALL Wn	Call Indirect Subroutine	1	4	SFA
		CALL.L Wn	Call Indirect Subroutine (long address)	1	4	SFA
19	CLR	CLR f	f = 0x0000	1	1	None
		CLR WREG	WREG = 0x0000	1	1	None
		CLR Ws	Ws = 0x0000	1	1	None
		CLR Acc, Wx, Wxd, Wy, Wyd, AWB	Clear Accumulator	1	1	OA,OB,SA,SB

**Note 1:** Read and Read-Modify-Write (e.g., bit operations and logical operations) on non-CPU SFRs incur an additional instruction cycle.

**2:** The divide instructions must be preceded with a "REPEAT #5" instruction, such that they are executed six consecutive times.

# dsPIC33CK256MP508 FAMILY

**TABLE 31-2: INSTRUCTION SET OVERVIEW (CONTINUED)**

Base Instr #	Assembly Mnemonic	Assembly Syntax	Description	# of Words	# of Cycles <sup>(1)</sup>	Status Flags Affected
20	CLRWDT	CLRWDT	Clear Watchdog Timer	1	1	WDTO,Sleep
21	COM	COM f	$f = \bar{f}$	1	1	N,Z
		COM f, WREG	$WREG = \bar{f}$	1	1	N,Z
		COM Ws, Wd	$Wd = \overline{Ws}$	1	1	N,Z
22	CP	CP f	Compare f with WREG	1	1	C,DC,N,OV,Z
		CP Wb, #lit8	Compare Wb with lit8	1	1	C,DC,N,OV,Z
		CP Wb, Ws	Compare Wb with Ws (Wb – Ws)	1	1	C,DC,N,OV,Z
23	CP0	CP0 f	Compare f with 0x0000	1	1	C,DC,N,OV,Z
		CP0 Ws	Compare Ws with 0x0000	1	1	C,DC,N,OV,Z
24	CPB	CPB f	Compare f with WREG, with Borrow	1	1	C,DC,N,OV,Z
		CPB Wb, #lit8	Compare Wb with lit8, with Borrow	1	1	C,DC,N,OV,Z
		CPB Wb, Ws	Compare Wb with Ws, with Borrow (Wb – Ws – C)	1	1	C,DC,N,OV,Z
25	CPSEQ	CPSEQ Wb, Wn	Compare Wb with Wn, Skip if =	1	1 (2 or 3)	None
	CPBEQ	CPBEQ Wb, Wn, Expr	Compare Wb with Wn, Branch if =	1	1 (5)	None
26	CPSGT	CPSGT Wb, Wn	Compare Wb with Wn, Skip if >	1	1 (2 or 3)	None
	CPBGT	CPBGT Wb, Wn, Expr	Compare Wb with Wn, Branch if >	1	1 (5)	None
27	CPSLT	CPSLT Wb, Wn	Compare Wb with Wn, Skip if <	1	1 (2 or 3)	None
		CPBLT	CPBLT Wb, Wn, Expr	Compare Wb with Wn, Branch if <	1	1 (5)
28	CPSNE	CPSNE Wb, Wn	Compare Wb with Wn, Skip if ≠	1	1 (2 or 3)	None
		CPBNE	CPBNE Wb, Wn, Expr	Compare Wb with Wn, Branch if ≠	1	1 (5)
29	CTXTSWP	CTXTSWP #lit3	Switch CPU Register Context to Context Defined by lit3	1	2	None
30	CTXTSWP	CTXTSWP Wn	Switch CPU Register Context to Context Defined by Wn	1	2	None
31	DAW.B	DAW.B Wn	Wn = Decimal Adjust Wn	1	1	C
32	DEC	DEC f	$f = f - 1$	1	1	C,DC,N,OV,Z
		DEC f, WREG	$WREG = f - 1$	1	1	C,DC,N,OV,Z
		DEC Ws, Wd	$Wd = Ws - 1$	1	1	C,DC,N,OV,Z
33	DEC2	DEC2 f	$f = f - 2$	1	1	C,DC,N,OV,Z
		DEC2 f, WREG	$WREG = f - 2$	1	1	C,DC,N,OV,Z
		DEC2 Ws, Wd	$Wd = Ws - 2$	1	1	C,DC,N,OV,Z
34	DISI	DISI #lit14	Disable Interrupts for k Instruction Cycles	1	1	None
35	DIVF	DIVF Wm, Wn	Signed 16/16-bit Fractional Divide	1	6	N,Z,C,OV
36	DIV.S <sup>(2)</sup>	DIV.S Wm, Wn	Signed 16/16-bit Integer Divide	1	6	N,Z,C,OV
		DIV.SD Wm, Wn	Signed 32/16-bit Integer Divide	1	6	N,Z,C,OV
37	DIV.U <sup>(2)</sup>	DIV.U Wm, Wn	Unsigned 16/16-bit Integer Divide	1	6	N,Z,C,OV
		DIV.UD Wm, Wn	Unsigned 32/16-bit Integer Divide	1	6	N,Z,C,OV
38	DIVF2 <sup>(2)</sup>	DIVF2 Wm, Wn	Signed 16/16-bit Fractional Divide (W1:W0 preserved)	1	6	N,Z,C,OV
39	DIV2.S <sup>(2)</sup>	DIV2.S Wm, Wn	Signed 16/16-bit Integer Divide (W1:W0 preserved)	1	6	N,Z,C,OV
		DIV2.SD Wm, Wn	Signed 32/16-bit Integer Divide (W1:W0 preserved)	1	6	N,Z,C,OV
40	DIV2.U <sup>(2)</sup>	DIV2.U Wm, Wn	Unsigned 16/16-bit Integer Divide (W1:W0 preserved)	1	6	N,Z,C,OV
		DIV2.UD Wm, Wn	Unsigned 32/16-bit Integer Divide (W1:W0 preserved)	1	6	N,Z,C,OV
41	DO	DO #lit15, Expr	Do Code to PC + Expr, lit15 + 1 Times	2	2	None
		DO Wn, Expr	Do code to PC + Expr, (Wn) + 1 Times	2	2	None

**Note 1:** Read and Read-Modify-Write (e.g., bit operations and logical operations) on non-CPU SFRs incur an additional instruction cycle.

**2:** The divide instructions must be preceded with a "REPEAT #5" instruction, such that they are executed six consecutive times.

# dsPIC33CK256MP508 FAMILY

**TABLE 31-2: INSTRUCTION SET OVERVIEW (CONTINUED)**

Base Instr #	Assembly Mnemonic	Assembly Syntax	Description	# of Words	# of Cycles <sup>(1)</sup>	Status Flags Affected
42	ED	ED $Wm*Wm, Acc, Wx, Wy, Wxd$	Euclidean Distance (no accumulate)	1	1	OA,OB,OAB,SA,SB,SAB
43	EDAC	EDAC $Wm*Wm, Acc, Wx, Wy, Wxd$	Euclidean Distance	1	1	OA,OB,OAB,SA,SB,SAB
44	EXCH	EXCH $Wns, Wnd$	Swap Wns with Wnd	1	1	None
46	FBCL	FBCL $Ws, Wnd$	Find Bit Change from Left (MSb) Side	1	1	C
47	FF1L	FF1L $Ws, Wnd$	Find First One from Left (MSb) Side	1	1	C
48	FF1R	FF1R $Ws, Wnd$	Find First One from Right (LSb) Side	1	1	C
49	FLIM	FLIM $Wb, Ws$	Force Data (Upper and Lower) Range Limit without Limit Excess Result	1	1	N,Z,OV
		FLIM.V $Wb, Ws, Wd$	Force Data (Upper and Lower) Range Limit with Limit Excess Result	1	1	N,Z,OV
50	GOTO	GOTO $Expr$	Go to Address	2	4	None
		GOTO $Wn$	Go to Indirect	1	4	None
		GOTO.L $Wn$	Go to Indirect (long address)	1	4	None
51	INC	INC $f$	$f = f + 1$	1	1	C,DC,N,OV,Z
		INC $f, WREG$	$WREG = f + 1$	1	1	C,DC,N,OV,Z
		INC $Ws, Wd$	$Wd = Ws + 1$	1	1	C,DC,N,OV,Z
52	INC2	INC2 $f$	$f = f + 2$	1	1	C,DC,N,OV,Z
		INC2 $f, WREG$	$WREG = f + 2$	1	1	C,DC,N,OV,Z
		INC2 $Ws, Wd$	$Wd = Ws + 2$	1	1	C,DC,N,OV,Z
53	IOR	IOR $f$	$f = f .IOR. WREG$	1	1	N,Z
		IOR $f, WREG$	$WREG = f .IOR. WREG$	1	1	N,Z
		IOR $\#lit10, Wn$	$Wd = lit10 .IOR. Wd$	1	1	N,Z
		IOR $Wb, Ws, Wd$	$Wd = Wb .IOR. Ws$	1	1	N,Z
		IOR $Wb, \#lit5, Wd$	$Wd = Wb .IOR. lit5$	1	1	N,Z
54	LAC	LAC $Wso, \#Slit4, Acc$	Load Accumulator	1	1	OA,OB,OAB,SA,SB,SAB
		LAC.D $Wso, \#Slit4, Acc$	Load Accumulator Double	1	2	OA,SA,OB,SB
56	LNK	LNK $\#lit14$	Link Frame Pointer	1	1	SFA
57	LSR	LSR $f$	$f = \text{Logical Right Shift } f$	1	1	C,N,OV,Z
		LSR $f, WREG$	$WREG = \text{Logical Right Shift } f$	1	1	C,N,OV,Z
		LSR $Ws, Wd$	$Wd = \text{Logical Right Shift } Ws$	1	1	C,N,OV,Z
		LSR $Wb, Wns, Wnd$	$Wnd = \text{Logical Right Shift } Wb \text{ by } Wns$	1	1	N,Z
		LSR $Wb, \#lit5, Wnd$	$Wnd = \text{Logical Right Shift } Wb \text{ by } lit5$	1	1	N,Z
58	MAC	MAC $Wm*Wn, Acc, Wx, Wxd, Wy, Wyd, AWB$	Multiply and Accumulate	1	1	OA,OB,OAB,SA,SB,SAB
		MAC $Wm*Wm, Acc, Wx, Wxd, Wy, Wyd$	Square and Accumulate	1	1	OA,OB,OAB,SA,SB,SAB
59	MAX	MAX $Acc$	Force Data Maximum Range Limit	1	1	N,OV,Z
		MAX.V $Acc, Wnd$	Force Data Maximum Range Limit with Result	1	1	N,OV,Z
60	MIN	MIN $Acc$	If Accumulator A Less than B Load Accumulator with B or vice versa	1	1	N,OV,Z
		MIN.V $Acc, Wd$	If Accumulator A Less than B Accumulator Force Minimum Data Range Limit with Limit Excess Result	1	1	N,OV,Z
		MINZ $Acc$	Accumulator Force Minimum Data Range Limit	1	1	N,OV,Z
		MINZ.V $Acc, Wd$	Accumulator Force Minimum Data Range Limit with Limit Excess Result	1	1	N,OV,Z

**Note 1:** Read and Read-Modify-Write (e.g., bit operations and logical operations) on non-CPU SFRs incur an additional instruction cycle.

**2:** The divide instructions must be preceded with a "REPEAT #5" instruction, such that they are executed six consecutive times.

# dsPIC33CK256MP508 FAMILY

**TABLE 31-2: INSTRUCTION SET OVERVIEW (CONTINUED)**

Base Instr #	Assembly Mnemonic	Assembly Syntax	Description	# of Words	# of Cycles <sup>(1)</sup>	Status Flags Affected	
61	MOV	MOV f, Wn	Move f to Wn	1	1	None	
		MOV f	Move f to f	1	1	None	
		MOV f, WREG	Move f to WREG	1	1	None	
		MOV #lit16, Wn	Move 16-bit Literal to Wn	1	1	None	
		MOV.b #lit8, Wn	Move 8-bit Literal to Wn	1	1	None	
		MOV Wn, f	Move Wn to f	1	1	None	
		MOV Wso, Wdo	Move Ws to Wd	1	1	None	
		MOV WREG, f	Move WREG to f	1	1	None	
		MOV.D Wns, Wd	Move Double from W(ns):W(ns + 1) to Wd	1	2	None	
MOV.D Ws, Wnd	Move Double from Ws to W(nd + 1):W(nd)	1	2	None			
62	MOVPAG	MOVPAG #lit10, DSRPAG	Move 10-bit Literal to DSRPAG	1	1	None	
		MOVPAG #lit8, TBLPAG	Move 8-bit Literal to TBLPAG	1	1	None	
		MOVPAG Ws, DSRPAG	Move Ws[9:0] to DSRPAG	1	1	None	
		MOVPAG Ws, TBLPAG	Move Ws[7:0] to TBLPAG	1	1	None	
64	MOVSAC	MOVSAC Acc, Wx, Wxd, Wy, Wyd, AWB	Prefetch and Store Accumulator	1	1	None	
65	MPY	MPY Wm*Wn, Acc, Wx, Wxd, Wy, Wyd	Multiply Wm by Wn to Accumulator	1	1	OA,OB,OAB,SA,SB,SAB	
		MPY Wm*Wm, Acc, Wx, Wxd, Wy, Wyd	Square Wm to Accumulator	1	1	OA,OB,OAB,SA,SB,SAB	
66	MPY.N	MPY.N Wm*Wn, Acc, Wx, Wxd, Wy, Wyd	-(Multiply Wm by Wn) to Accumulator	1	1	None	
67	MSC	MSC Wm*Wm, Acc, Wx, Wxd, Wy, Wyd, AWB	Multiply and Subtract from Accumulator	1	1	OA,OB,OAB,SA,SB,SAB	
68	MUL	MUL.SS Wb, Ws, Wnd	{Wnd + 1, Wnd} = Signed(Wb) * Signed(Ws)	1	1	None	
		MUL.SS Wb, Ws, Acc	Accumulator = Signed(Wb) * Signed(Ws)	1	1	None	
		MUL.SU Wb, Ws, Wnd	{Wnd + 1, Wnd} = Signed(Wb) * Unsigned(Ws)	1	1	None	
		MUL.SU Wb, Ws, Acc	Accumulator = Signed(Wb) * Unsigned(Ws)	1	1	None	
		MUL.SU Wb, #lit5, Acc	Accumulator = Signed(Wb) * Unsigned(lit5)	1	1	None	
		MUL.US Wb, Ws, Wnd	{Wnd + 1, Wnd} = Unsigned(Wb) * Signed(Ws)	1	1	None	
		MUL.US Wb, Ws, Acc	Accumulator = Unsigned(Wb) * Signed(Ws)	1	1	None	
		MUL.UU Wb, Ws, Wnd	{Wnd + 1, Wnd} = Unsigned(Wb) * Unsigned(Ws)	1	1	None	
		MUL.UU Wb, #lit5, Acc	Accumulator = Unsigned(Wb) * Unsigned(lit5)	1	1	None	
		MUL.UU Wb, Ws, Acc	Accumulator = Unsigned(Wb) * Unsigned(Ws)	1	1	None	
		MULW.SS Wb, Ws, Wnd	Wnd = Signed(Wb) * Signed(Ws)	1	1	None	
		MULW.SU Wb, Ws, Wnd	Wnd = Signed(Wb) * Unsigned(Ws)	1	1	None	
		MULW.US Wb, Ws, Wnd	Wnd = Unsigned(Wb) * Signed(Ws)	1	1	None	
		MULW.UU Wb, Ws, Wnd	Wnd = Unsigned(Wb) * Unsigned(Ws)	1	1	None	
		MUL.SU Wb, #lit5, Wnd	{Wnd + 1, Wnd} = Signed(Wb) * Unsigned(lit5)	1	1	None	
		MUL.SU Wb, #lit5, Wnd	Wnd = Signed(Wb) * Unsigned(lit5)	1	1	None	
		MUL.UU Wb, #lit5, Wnd	{Wnd + 1, Wnd} = Unsigned(Wb) * Unsigned(lit5)	1	1	None	
		MUL.UU Wb, #lit5, Wnd	Wnd = Unsigned(Wb) * Unsigned(lit5)	1	1	None	
		MUL	f	W3:W2 = f * WREG	1	1	None

- Note 1:** Read and Read-Modify-Write (e.g., bit operations and logical operations) on non-CPU SFRs incur an additional instruction cycle.  
**Note 2:** The divide instructions must be preceded with a "REPEAT #5" instruction, such that they are executed six consecutive times.

# dsPIC33CK256MP508 FAMILY

**TABLE 31-2: INSTRUCTION SET OVERVIEW (CONTINUED)**

Base Instr #	Assembly Mnemonic	Assembly Syntax	Description	# of Words	# of Cycles <sup>(1)</sup>	Status Flags Affected
69	NEG	NEG <i>Acc</i>	Negate Accumulator	1	1	OA,OB,OAB,SA,SB,SAB
		NEG <i>f</i>	$f = \bar{f} + 1$	1	1	C,DC,N,OV,Z
		NEG <i>f, WREG</i>	$WREG = \bar{f} + 1$	1	1	C,DC,N,OV,Z
		NEG <i>Ws, Wd</i>	$Wd = \bar{Ws} + 1$	1	1	C,DC,N,OV,Z
70	NOP	NOP	No Operation	1	1	None
		NOPR	No Operation	1	1	None
71	NORM	NORM <i>Acc, Wd</i>	Normalize Accumulator	1	1	N,OV,Z
72	POP	POP <i>f</i>	Pop <i>f</i> from Top-of-Stack (TOS)	1	1	None
		POP <i>Wdo</i>	Pop from Top-of-Stack (TOS) to <i>Wdo</i>	1	1	None
		POP.D <i>Wnd</i>	Pop from Top-of-Stack (TOS) to <i>W(nd):W(nd + 1)</i>	1	2	None
		POP.S	Pop Shadow Registers	1	1	All
73	PUSH	PUSH <i>f</i>	Push <i>f</i> to Top-of-Stack (TOS)	1	1	None
		PUSH <i>Wso</i>	Push <i>Wso</i> to Top-of-Stack (TOS)	1	1	None
		PUSH.D <i>Wns</i>	Push <i>W(ns):W(ns + 1)</i> to Top-of-Stack (TOS)	1	2	None
		PUSH.S	Push Shadow Registers	1	1	None
74	PWRSVAV	PWRSVAV #lit1	Go into Sleep or Idle mode	1	1	WDTO,Sleep
75	RCALL	RCALL <i>Expr</i>	Relative Call	1	4	SFA
		RCALL <i>Wn</i>	Computed Call	1	4	SFA
76	REPEAT	REPEAT #lit15	Repeat Next Instruction lit15 + 1 times	1	1	None
		REPEAT <i>Wn</i>	Repeat Next Instruction ( <i>Wn</i> ) + 1 times	1	1	None
77	RESET	RESET	Software Device Reset	1	1	None
78	RETFIE	RETFIE	Return from Interrupt	1	6 (5)	SFA
79	RETLW	RETLW #lit10, <i>Wn</i>	Return with Literal in <i>Wn</i>	1	6 (5)	SFA
80	RETURN	RETURN	Return from Subroutine	1	6 (5)	SFA
81	RLC	RLC <i>f</i>	$f = \text{Rotate Left through Carry } f$	1	1	C,N,Z
		RLC <i>f, WREG</i>	$WREG = \text{Rotate Left through Carry } f$	1	1	C,N,Z
		RLC <i>Ws, Wd</i>	$Wd = \text{Rotate Left through Carry } Ws$	1	1	C,N,Z
82	RLNC	RLNC <i>f</i>	$f = \text{Rotate Left (No Carry) } f$	1	1	N,Z
		RLNC <i>f, WREG</i>	$WREG = \text{Rotate Left (No Carry) } f$	1	1	N,Z
		RLNC <i>Ws, Wd</i>	$Wd = \text{Rotate Left (No Carry) } Ws$	1	1	N,Z
83	RRC	RRC <i>f</i>	$f = \text{Rotate Right through Carry } f$	1	1	C,N,Z
		RRC <i>f, WREG</i>	$WREG = \text{Rotate Right through Carry } f$	1	1	C,N,Z
		RRC <i>Ws, Wd</i>	$Wd = \text{Rotate Right through Carry } Ws$	1	1	C,N,Z
84	RRNC	RRNC <i>f</i>	$f = \text{Rotate Right (No Carry) } f$	1	1	N,Z
		RRNC <i>f, WREG</i>	$WREG = \text{Rotate Right (No Carry) } f$	1	1	N,Z
		RRNC <i>Ws, Wd</i>	$Wd = \text{Rotate Right (No Carry) } Ws$	1	1	N,Z
85	SAC	SAC <i>Acc, #Slit4, Wdo</i>	Store Accumulator	1	1	None
		SAC.R <i>Acc, #Slit4, Wdo</i>	Store Rounded Accumulator	1	1	None
86	SE	SE <i>Ws, Wnd</i>	$Wnd = \text{Sign-Extended } Ws$	1	1	C,N,Z
87	SETM	SETM <i>f</i>	$f = 0xFFFF$	1	1	None
		SETM <i>WREG</i>	$WREG = 0xFFFF$	1	1	None
		SETM <i>Ws</i>	$Ws = 0xFFFF$	1	1	None
88	SFTAC	SFTAC <i>Acc, Wn</i>	Arithmetic Shift Accumulator by ( <i>Wn</i> )	1	1	OA,OB,OAB,SA,SB,SAB
		SFTAC <i>Acc, #Slit6</i>	Arithmetic Shift Accumulator by Slit6	1	1	OA,OB,OAB,SA,SB,SAB

**Note 1:** Read and Read-Modify-Write (e.g., bit operations and logical operations) on non-CPU SFRs incur an additional instruction cycle.

**Note 2:** The divide instructions must be preceded with a "REPEAT #5" instruction, such that they are executed six consecutive times.

# dsPIC33CK256MP508 FAMILY

**TABLE 31-2: INSTRUCTION SET OVERVIEW (CONTINUED)**

Base Instr #	Assembly Mnemonic	Assembly Syntax	Description	# of Words	# of Cycles <sup>(1)</sup>	Status Flags Affected
89	SL	SL f	f = Left Shift f	1	1	C,N,OV,Z
		SL f, WREG	WREG = Left Shift f	1	1	C,N,OV,Z
		SL Ws, Wd	Wd = Left Shift Ws	1	1	C,N,OV,Z
		SL Wb, Wns, Wnd	Wnd = Left Shift Wb by Wns	1	1	N,Z
		SL Wb, #lit5, Wnd	Wnd = Left Shift Wb by lit5	1	1	N,Z
91	SUB	SUB Acc	Subtract Accumulators	1	1	OA,OB,OAB,SA,SB,SAB
		SUB f	f = f - WREG	1	1	C,DC,N,OV,Z
		SUB f, WREG	WREG = f - WREG	1	1	C,DC,N,OV,Z
		SUB #lit10, Wn	Wn = Wn - lit10	1	1	C,DC,N,OV,Z
		SUB Wb, Ws, Wd	Wd = Wb - Ws	1	1	C,DC,N,OV,Z
		SUB Wb, #lit5, Wd	Wd = Wb - lit5	1	1	C,DC,N,OV,Z
92	SUBB	SUBB f	f = f - WREG - ( $\overline{C}$ )	1	1	C,DC,N,OV,Z
		SUBB f, WREG	WREG = f - WREG - ( $\overline{C}$ )	1	1	C,DC,N,OV,Z
		SUBB #lit10, Wn	Wn = Wn - lit10 - ( $\overline{C}$ )	1	1	C,DC,N,OV,Z
		SUBB Wb, Ws, Wd	Wd = Wb - Ws - ( $\overline{C}$ )	1	1	C,DC,N,OV,Z
		SUBB Wb, #lit5, Wd	Wd = Wb - lit5 - ( $\overline{C}$ )	1	1	C,DC,N,OV,Z
93	SUBR	SUBR f	f = WREG - f	1	1	C,DC,N,OV,Z
		SUBR f, WREG	WREG = WREG - f	1	1	C,DC,N,OV,Z
		SUBR Wb, Ws, Wd	Wd = Ws - Wb	1	1	C,DC,N,OV,Z
		SUBR Wb, #lit5, Wd	Wd = lit5 - Wb	1	1	C,DC,N,OV,Z
94	SUBBR	SUBBR f	f = WREG - f - ( $\overline{C}$ )	1	1	C,DC,N,OV,Z
		SUBBR f, WREG	WREG = WREG - f - ( $\overline{C}$ )	1	1	C,DC,N,OV,Z
		SUBBR Wb, Ws, Wd	Wd = Ws - Wb - ( $\overline{C}$ )	1	1	C,DC,N,OV,Z
		SUBBR Wb, #lit5, Wd	Wd = lit5 - Wb - ( $\overline{C}$ )	1	1	C,DC,N,OV,Z
95	SWAP	SWAP.b Wn	Wn = Nibble Swap Wn	1	1	None
		SWAP Wn	Wn = Byte Swap Wn	1	1	None
96	TBLRDH	TBLRDH Ws, Wd	Read Prog[23:16] to Wd[7:0]	1	5	None
97	TBLRDL	TBLRDL Ws, Wd	Read Prog[15:0] to Wd	1	5	None
98	TBLWTH	TBLWTH Ws, Wd	Write Ws[7:0] to Prog[23:16]	1	2	None
99	TBLWTL	TBLWTL Ws, Wd	Write Ws to Prog[15:0]	1	2	None
101	ULNK	ULNK	Unlink Frame Pointer	1	1	SFA
104	XOR	XOR f	f = f .XOR. WREG	1	1	N,Z
		XOR f, WREG	WREG = f .XOR. WREG	1	1	N,Z
		XOR #lit10, Wn	Wd = lit10 .XOR. Wd	1	1	N,Z
		XOR Wb, Ws, Wd	Wd = Wb .XOR. Ws	1	1	N,Z
		XOR Wb, #lit5, Wd	Wd = Wb .XOR. lit5	1	1	N,Z
105	ZE	ZE Ws, Wnd	Wnd = Zero-Extend Ws	1	1	C,Z,N

**Note 1:** Read and Read-Modify-Write (e.g., bit operations and logical operations) on non-CPU SFRs incur an additional instruction cycle.

**2:** The divide instructions must be preceded with a "REPEAT #5" instruction, such that they are executed six consecutive times.

## 32.0 DEVELOPMENT SUPPORT

Move a design from concept to production in record time with Microchip's award-winning development tools. Microchip tools work together to provide state of the art debugging for any project with easy-to-use Graphical User Interfaces (GUIs) in our free MPLAB® X and Atmel Studio Integrated Development Environments (IDEs), and our code generation tools. Providing the ultimate ease-of-use experience, Microchip's line of programmers, debuggers and emulators work seamlessly with our software tools. Microchip development boards help evaluate the best silicon device for an application, while our line of third party tools round out our comprehensive development tool solutions.

Microchip's MPLAB X and Atmel Studio ecosystems provide a variety of embedded design tools to consider, which support multiple devices, such as PIC® MCUs, AVR® MCUs, SAM MCUs and dsPIC® DSCs. MPLAB X tools are compatible with Windows®, Linux® and Mac® operating systems while Atmel Studio tools are compatible with Windows.

Go to the following website for more information and details:

<https://www.microchip.com/development-tools/>

# dsPIC33CK256MP508 FAMILY

---

NOTES:



# dsPIC33CK256MP508 FAMILY

## 33.0 ELECTRICAL CHARACTERISTICS

This section provides an overview of the dsPIC33CK256MP508 family electrical characteristics. Additional information will be provided in future revisions of this document as it becomes available.

Absolute maximum ratings for the dsPIC33CK256MP508 family are listed below. Exposure to these maximum rating conditions for extended periods may affect device reliability. Functional operation of the device at these, or any other conditions above the parameters indicated in the operation listings of this specification, is not implied.

### Absolute Maximum Ratings<sup>(1)</sup>

Ambient temperature under bias .....	-40°C to +125°C
Storage temperature .....	-65°C to +150°C
Voltage on VDD with respect to VSS .....	-0.3V to +4.0V
Voltage on any pin that is not 5V tolerant with respect to VSS <sup>(3)</sup> .....	-0.3V to (VDD + 0.3V)
Voltage on any 5V tolerant pin with respect to VSS when VDD ≥ 3.0V <sup>(3)</sup> .....	-0.3V to +5.5V
Voltage on any 5V tolerant pin with respect to VSS when VDD < 3.0V <sup>(3)</sup> .....	-0.3V to +3.6V
Maximum current out of VSS pin .....	300 mA
Maximum current into VDD pin <sup>(2)</sup> .....	300 mA
Maximum current sunk/sourced by any 4x I/O pin .....	15 mA
Maximum current sunk/sourced by any 8x I/O pin .....	25 mA
Maximum current sunk by a group of I/Os between two VSS pins <sup>(4)</sup> .....	75 mA
Maximum current sourced by a group of I/Os between two VDD pins <sup>(4)</sup> .....	75 mA
Maximum current sunk by all I/Os <sup>(2,5)</sup> .....	200 mA
Maximum current sourced by all I/Os <sup>(2,5)</sup> .....	200 mA

**Note 1:** Stresses above those listed under “Absolute Maximum Ratings” may cause permanent damage to the device. This is a stress rating only and functional operation of the device at those, or any other conditions above those indicated in the operation listings of this specification, is not implied. Exposure to maximum rating conditions for extended periods may affect device reliability.

**2:** Maximum allowable current is a function of device maximum power dissipation (see [Table 33-2](#)).

**3:** See the “[Pin Diagrams](#)” section for the 5V tolerant pins.

**4:** Not applicable to AVDD and AVSS pins.

**5:** For 28-pin packages, the maximum current sunk/sourced by all I/Os is limited by 150 mA.

# dsPIC33CK256MP508 FAMILY

## 33.1 DC Characteristics

**TABLE 33-1: OPERATING MIPS vs. VOLTAGE**

VDD Range	Temperature Range	Maximum CPU Clock Frequency
3.0V to 3.6V	-40°C to +85°C	100
3.0V to 3.6V	-40°C to +125°C	100

**TABLE 33-2: THERMAL OPERATING CONDITIONS**

Rating	Symbol	Min.	Max.	Unit
Industrial Temperature Devices				
Operating Junction Temperature Range	TJ	-40	+125	°C
Operating Ambient Temperature Range	TA	-40	+85	°C
Extended Temperature Devices				
Operating Junction Temperature Range	TJ	-40	+140	°C
Operating Ambient Temperature Range	TA	-40	+125	°C
Power Dissipation: Internal Chip Power Dissipation: $P_{INT} = V_{DD} \times (I_{DD} - \Sigma I_{OH})$ I/O Pin Power Dissipation: $I/O = \Sigma (\{V_{DD} - V_{OH}\} \times I_{OH}) + \Sigma (V_{OL} \times I_{OL})$	PD	PINT + PI/O		W
Maximum Allowed Power Dissipation	PDMAX	$(T_J - T_A)/\theta_{JA}$		W

**TABLE 33-3: THERMAL PACKAGING CHARACTERISTICS<sup>(1)</sup>**

Characteristic	Symbol	Typ.	Unit
Package Thermal Resistance, 80-Pin TQFP 12x12x1 mm	$\theta_{JA}$	50.67	°C/W
Package Thermal Resistance, 64-Pin TQFP 10x10x1.0 mm	$\theta_{JA}$	45.7	°C/W
Package Thermal Resistance, 64-Pin QFN 9x9 mm	$\theta_{JA}$	18.7	°C/W
Package Thermal Resistance, 48-Pin TQFP 7x7 mm	$\theta_{JA}$	62.76	°C/W
Package Thermal Resistance, 48-Pin UQFN 6x6 mm	$\theta_{JA}$	27.6	°C/W
Package Thermal Resistance, 36-Pin UQFN 5x5 mm	$\theta_{JA}$	29.2	°C/W
Package Thermal Resistance, 28-Pin UQFN 6x6 mm	$\theta_{JA}$	22.41	°C/W
Package Thermal Resistance, 28-Pin SSOP 5.30 mm	$\theta_{JA}$	52.84	°C/W

**Note 1:** Junction to ambient thermal resistance, Theta-JA ( $\theta_{JA}$ ) numbers are achieved by package simulations.

# dsPIC33CK256MP508 FAMILY

**TABLE 33-4: OPERATING VOLTAGE SPECIFICATIONS**

Operating Conditions: 3.0V to 3.6V (unless otherwise stated) <sup>(1)</sup>							
Operating temperature -40°C ≤ TA ≤ +85°C for Industrial -40°C ≤ TA ≤ +125°C for Extended							
Param No.	Symbol	Characteristic	Min.	Typ.	Max.	Units	Conditions
<b>Operating Voltage</b>							
DC10	VDD	<b>Supply Voltage</b>	3.0	—	3.6	V	
DC11	AVDD	<b>Supply Voltage</b>	Greater of: VDD – 0.3 or 3.0	—	Lesser of: VDD + 0.3 or 3.6	V	The difference between AVDD supply and VDD supply must not exceed ±300 mV at all times, including during device power-up
DC16	VPOR	<b>VDD Start Voltage</b> to Ensure Internal Power-on Reset Signal	—	—	VSS	V	
DC17	SVDD	<b>VDD Rise Rate</b> to Ensure Internal Power-on Reset Signal	0.03	—	—	V/ms	0V-3V in 100 ms
BO10	VBOR	<b>BOR Event on VDD Transition</b> High-to-Low	2.68	2.84	2.99	V	
BO11	VPOR	<b>POR Event on VDD Transition</b> High-to-Low	—	1.65	—	V	VDD ( <b>Notes 2,3</b> )

- Note 1:** Device is functional at VBORMIN < VDD < VDDMIN. Analog modules (ADC and comparators) may have degraded performance.
- 2:** Parameters are characterized but not tested.
- 3:** If VDD drops below the BO11 value, VDD must be brought down to 0V before ramping the device back up to operation range.

**TABLE 33-5: VOLTAGE REGULATOR SPECIFICATIONS**

Operating Conditions: 3.0V to 3.6V (unless otherwise stated) <sup>(1)</sup>							
Operating temperature -40°C ≤ TA ≤ +85°C for Industrial -40°C ≤ TA ≤ +125°C for Extended							
Param No.	Symbol	Characteristic	Min.	Typ.	Max.	Units	Conditions
<b>Operating Voltage</b>							
DVR20	VDDCORE	Regulator Output Voltage	1.08	—	1.32	V	For VREG and VREGPLL
DVR22	VVREG_READY	Regulator Ready Comparator Voltage	1.08	—	—	V	Combined highest voltage for VREG and VREGPLL comparators ( <b>Notes 2,3</b> )

- Note 1:** Device is functional at VBORMIN < VDD < VDDMIN. Analog modules (ADC and comparators) may have degraded performance.
- 2:** Device is functional down to the Regulator Ready Comparator Voltage trip point (VVREG\_READY ≤ VDDCORE).
- 3:** Functionality of the VREG monitor is tested in production, assuring the monitor's Reset protection. Absolute trip point value is determined based on a combination of bench validation, simulation and production test results.

# dsPIC33CK256MP508 FAMILY

**TABLE 33-6: OPERATING CURRENT (IDD)<sup>(2)</sup>**

Operating Conditions: 3.0V to 3.6V (unless otherwise stated)					
Operating temperature -40°C ≤ TA ≤ +85°C for Industrial					
-40°C ≤ TA ≤ +125°C for Extended					
Parameter No.	Typ. <sup>(1)</sup>	Max.	Units	Conditions	
DC20	7.76	10.7	mA	-40°C	3.3V 10 MIPS (N1 = 1, N2 = 5, N3 = 2, M = 50, FVCO = 400 MHz, FPLLO = 40 MHz)
	7.49	10	mA	+25°C	
	7.82	15.5	mA	+85°C	
	10.32	23.5	mA	+125°C	
DC21	10.36	13.1	mA	-40°C	3.3V 20 MIPS (N1 = 1, N2 = 5, N3 = 1, M = 50, FVCO = 400 MHz, FPLLO = 80 MHz)
	10.09	12.45	mA	+25°C	
	10.42	17.5	mA	+85°C	
	12.89	25.5	mA	+125°C	
DC22	14.54	17.45	mA	-40°C	3.3V 40 MIPS (N1 = 1, N2 = 3, N3 = 1, M = 60, FVCO = 480 MHz, FPLLO = 160 MHz)
	14.26	16.7	mA	+25°C	
	14.58	22	mA	+85°C	
	17.06	30	mA	+125°C	
DC23	22.2	25.4	mA	-40°C	3.3V 70 MIPS (N1 = 1, N2 = 2, N3 = 1, M = 70, FVCO = 560 MHz, FPLLO = 280 MHz)
	21.91	24.9	mA	+25°C	
	22.21	30.75	mA	+85°C	
	24.65	37.5	mA	+125°C	
DC24	27.36	30.7	mA	-40°C	3.3V 90 MIPS (N1 = 1, N2 = 2, N3 = 1, M = 90, FVCO = 720 MHz, FPLLO = 360 MHz)
	26.96	30.5	mA	+25°C	
	26.68	35	mA	+85°C	
	29.01	42	mA	+125°C	
DC25	27.14	30.9	mA	-40°C	3.3V 100 MIPS (N1 = 1, N2 = 1, N3 = 1, M = 50, FVCO = 400 MHz, FPLLO = 400 MHz)
	26.54	30.1	mA	+25°C	
	26.79	35	mA	+85°C	
	29.23	42.5	mA	+125°C	

**Note 1:** Data in the "Typ." column are for design guidance only and are not tested.

**2:** Base Run current (IDD) is measured as follows:

- Oscillator is switched to EC+PLL mode in software
- OSC1 pin is driven with external 8 MHz square wave with levels from 0.3V to VDD – 0.3V
- OSC2 is configured as an I/O in the Configuration Words (OSCIOFNC (FOSC[2]) = 0)
- FSCM is disabled (FCKSM[1:0] (FOSC[7:6]) = 01)
- Watchdog Timer is disabled (FWDT[15] = 0 and WDTCONL[15] = 0)
- All I/O pins (except OSC1) are configured as outputs and driving low
- No peripheral modules are operating or being clocked (defined PMDx bits are all '1's)
- JTAG is disabled (JTAGEN (FICD[5]) = 0)
- NOP instructions are executed in `while(1)` loop

# dsPIC33CK256MP508 FAMILY

**TABLE 33-7: IDLE CURRENT (I<sub>IDLE</sub>)<sup>(2)</sup>**

Operating Conditions: 3.0V to 3.6V (unless otherwise stated)						
Operating temperature -40°C ≤ T <sub>A</sub> ≤ +85°C for Industrial						
-40°C ≤ T <sub>A</sub> ≤ +125°C for Extended						
Parameter No.	Typ. <sup>(1)</sup>	Max.	Units	Conditions		
DC40	6.41	8.47	mA	-40°C	3.3V	10 MIPS (N1 = 1, N2 = 5, N3 = 2, M = 50, F <sub>VCO</sub> = 400 MHz, F <sub>P</sub> LLO = 40 MHz)
	6.15	7.57	mA	+25°C		
	6.45	13	mA	+85°C		
	8.95	22	mA	+125°C		
DC41	7.31	10.1	mA	-40°C	3.3V	20 MIPS (N1 = 1, N2 = 5, N3 = 1, M = 50, F <sub>VCO</sub> = 400 MHz, F <sub>P</sub> LLO = 80 MHz)
	7.04	9.1	mA	+25°C		
	7.36	14.75	mA	+85°C		
	9.83	22.75	mA	+125°C		
DC42	9.4	12.3	mA	-40°C	3.3V	40 MIPS (N1 = 1, N2 = 3, N3 = 1, M = 60, F <sub>VCO</sub> = 480 MHz, F <sub>P</sub> LLO = 160 MHz)
	9.13	11.2	mA	+25°C		
	9.45	16.5	mA	+85°C		
	11.92	25	mA	+125°C		
DC43	12.39	15.3	mA	-40°C	3.3V	70 MIPS (N1 = 1, N2 = 2, N3 = 1, M = 70, F <sub>VCO</sub> = 560 MHz, F <sub>P</sub> LLO = 280 MHz)
	12.11	14.3	mA	+25°C		
	12.43	19.75	mA	+85°C		
	14.89	28.25	mA	+125°C		
DC44	14.78	17.85	mA	-40°C	3.3V	90 MIPS (N1 = 1, N2 = 2, N3 = 1, M = 90, F <sub>VCO</sub> = 720 MHz, F <sub>P</sub> LLO = 360 MHz)
	14.5	16.9	mA	+25°C		
	14.81	22.5	mA	+85°C		
	17.26	29.5	mA	+125°C		
DC45	14.44	17.55	mA	-40°C	3.3V	100 MIPS (N1 = 1, N2 = 1, N3 = 1, M = 50, F <sub>VCO</sub> = 400 MHz, F <sub>P</sub> LLO = 400 MHz)
	14.15	16.5	mA	+25°C		
	14.46	22.25	mA	+85°C		
	16.9	30	mA	+125°C		

**Note 1:** Data in the "Typ." column are for design guidance only and are not tested.

**2:** Base Idle current (I<sub>IDLE</sub>) is measured as follows:

- Oscillator is switched to EC+PLL mode in software
- OSC1 pin is driven with external 8 MHz square wave with levels from 0.3V to V<sub>DD</sub> - 0.3V
- OSC2 is configured as an I/O in the Configuration Words (OSCIOFNC (FOSC[2]) = 0)
- FSCM is disabled (FCKSM[1:0] (FOSC[7:6]) = 01)
- Watchdog Timer is disabled (FWDT[15] = 0 and WDTCONL[15] = 0)
- All I/O pins (except OSC1) are configured as outputs and driving low
- No peripheral modules are operating or being clocked (defined PMDx bits are all '1's)
- JTAG is disabled (JTAGEN (FICD[5]) = 0)
- Flash in standby with NVMSIDL (NVMCON[12]) = 1

# dsPIC33CK256MP508 FAMILY

**TABLE 33-8: POWER-DOWN CURRENT (IPD)<sup>(2)</sup>**

Operating Conditions: 3.0V to 3.6V (unless otherwise stated)					
Operating temperature -40°C ≤ TA ≤ +85°C for Industrial					
-40°C ≤ TA ≤ +125°C for Extended					
Parameter No.	Characteristic	Typ. <sup>(1)</sup>	Max.	Units	Conditions
DC60	Base Power-Down Current	270	650	μA	-40°C
		419	1400	μA	+25°C
		940	7250	μA	+85°C
		5.59	18.5	mA	+125°C <sup>(3)</sup>
					3.3V

**Note 1:** Data in the “Typ.” column are for design guidance only and are not tested.

**Note 2:** Base Sleep current (IPD) is measured as follows:

- OSC1 pin is driven with external 8 MHz square wave with levels from 0.3V to VDD – 0.3V
- OSC2 is configured as an I/O in the Configuration Words (OSCIOFNC (FOSC[2]) = 0)
- FSCM is disabled (FCKSM[1:0] (FOSC[7:6]) = 01)
- Watchdog Timer is disabled (FWDT[15] = 0 and WDTCONL[15] = 0)
- All I/O pins (except OSC1) are configured as outputs and driving low
- No peripheral modules are operating or being clocked (defined PMDx bits are all ‘1’s)
- JTAG is disabled (JTAGEN (FICD[5]) = 0)
- The regulators are in Standby mode (VREGS (RCON[8]) = 0)
- The regulators are in Low-Power mode (LPWREN (VREGCON[15]) = 1)

**Note 3:** The regulators are in High-Power mode (LPWREN (VREGCON[15]) = 0).

**TABLE 33-9: DOZE CURRENT (IDOZE)**

Operating Conditions: 3.0V to 3.6V (unless otherwise stated)					
Operating temperature -40°C ≤ TA ≤ +85°C for Industrial					
-40°C ≤ TA ≤ +125°C for Extended					
Parameter No.	Typ. <sup>(1)</sup>	Max.	Doze Ratio	Units	Conditions
DC70	18.19	20	1:2	mA	-40°C
	12.66	15	1:128	mA	-40°C
	17.54	20.15	1:2	mA	+25°C
	12.39	14.7	1:128	mA	+25°C
	17.85	25	1:2	mA	+85°C
	12.7	20	1:128	mA	+85°C
	20.32	32.5	1:2	mA	+125°C
	15.17	28.5	1:128	mA	+125°C
DC71	22.3	25.55	1:2	mA	-40°C
	14.83	17.25	1:128	mA	-40°C
	21.86	25.05	1:2	mA	+25°C
	14.55	16.95	1:128	mA	+25°C
	22.16	30	1:2	mA	+85°C
	14.86	22	1:128	mA	+85°C
	24.62	36.5	1:2	mA	+125°C
	17.31	30	1:128	mA	+125°C
					3.3V
					70 MIPS (N = 1, N2 = 2, N3 = 1, M = 70, FVCO = 560 MHz, FPLLO = 280 MHz)
					3.3V
					100 MIPS (N = 1, N2 = 1, N3 = 1, M = 50, FVCO = 400 MHz, FPLLO = 400 MHz)

**Note 1:** Data in the “Typ.” column are for design guidance only and are not tested.

# dsPIC33CK256MP508 FAMILY

**TABLE 33-10: WATCHDOG TIMER DELTA CURRENT ( $\Delta I_{WDT}$ )<sup>(1)</sup>**

Operating Conditions: 3.0V to 3.6V (unless otherwise stated)					
Operating temperature -40°C ≤ T <sub>A</sub> ≤ +85°C for Industrial					
-40°C ≤ T <sub>A</sub> ≤ +125°C for Extended					
Parameter No.	Typ.	Max.	Units	Conditions	
DC61	0.75	5	μA	-40°C	3.3V
	2.0	12	μA	+25°C	
	3.88	24	μA	+85°C	
	5.69	40	μA	+125°C	

**Note 1:** The  $\Delta I_{WDT}$  current is the additional current consumed when the module is enabled. This current should be added to the base IPD current. All parameters are characterized but not tested during manufacturing.

**TABLE 33-11: PWM DELTA CURRENT<sup>(1)</sup>**

Operating Conditions: 3.0V to 3.6V (unless otherwise stated)					
Operating temperature -40°C ≤ T <sub>A</sub> ≤ +85°C for Industrial					
-40°C ≤ T <sub>A</sub> ≤ +125°C for Extended					
Parameter No.	Typ.	Max.	Units	Conditions	
DC100	5.96	6.6	mA	-40°C	3.3V PWM Output Frequency = 500 kHz, PWM Input (AF <sub>P</sub> LL <sub>O</sub> = 500 MHz) (AVCO = 1000 MHz, PLLFBD = 125, APLLDIV1 = 2)
	5.99	6.7	mA	+25°C	
	5.92	6.9	mA	+85°C	
	5.47	7	mA	+125°C	
DC101	4.89	5.4	mA	-40°C	3.3V PWM Output Frequency = 500 kHz, PWM Input (AF <sub>P</sub> LL <sub>O</sub> = 400 MHz), (AVCO = 400 MHz, PLLFBD = 50, APLLDIV1 = 1)
	4.91	5.5	mA	+25°C	
	4.85	5.7	mA	+85°C	
	4.42	5.7	mA	+125°C	
DC102	2.77	3.7	mA	-40°C	3.3V PWM Output Frequency = 500 kHz, PWM Input (AF <sub>P</sub> LL <sub>O</sub> = 200 MHz), (AVCO = 400 MHz, PLLFBD = 50, APLLDIV1 = 2)
	2.75	3.7	mA	+25°C	
	2.7	3.7	mA	+85°C	
	2.26	3.7	mA	+125°C	
DC103	1.67	2	mA	-40°C	3.3V PWM Output Frequency = 500 kHz, PWM Input (AF <sub>P</sub> LL <sub>O</sub> = 100 MHz), (AVCO = 400 MHz, PLLFBD = 50, APLLDIV1 = 4)
	1.66	2.2	mA	+25°C	
	1.63	2.3	mA	+85°C	
	1.17	2.3	mA	+125°C	

**Note 1:** APLL current is not included. The APLL current will be the same if more than one PWM is running. Listed delta currents are for only one PWM instance when HREN = 0 (PGxCONL[7]). All parameters are characterized but not tested during manufacturing.

# dsPIC33CK256MP508 FAMILY

**TABLE 33-12: APLL DELTA CURRENT**

<b>Operating Conditions: 3.0V to 3.6V (unless otherwise stated)</b>					
Operating temperature $-40^{\circ}\text{C} \leq T_A \leq +85^{\circ}\text{C}$ for Industrial $-40^{\circ}\text{C} \leq T_A \leq +125^{\circ}\text{C}$ for Extended					
Parameter No.	Typ.	Max.	Units	Conditions <sup>(1)</sup>	
DC110	5.93	6.6	mA	$-40^{\circ}\text{C}$	3.3V AFPLLO = 500 MHz (AVCO = 1000 MHz, PLLFBD = 125, APLLDIV1 = 2)
	5.95	7	mA	$+25^{\circ}\text{C}$	
	6.15	7.6	mA	$+85^{\circ}\text{C}$	
	7.15	9	mA	$+125^{\circ}\text{C}$	
DC111	2.72	3.3	mA	$-40^{\circ}\text{C}$	3.3V AFPLLO = 400 MHz (AVCO = 400 MHz, PLLFBD = 50, APLLDIV1 = 1)
	2.74	3.7	mA	$+25^{\circ}\text{C}$	
	2.92	4.3	mA	$+85^{\circ}\text{C}$	
	3.87	5.6	mA	$+125^{\circ}\text{C}$	
DC112	1.39	2.7	mA	$-40^{\circ}\text{C}$	3.3V AFPLLO = 200 MHz (AVCO = 400 MHz, PLLFBD = 50, APLLDIV1 = 2)
	1.49	2.7	mA	$+25^{\circ}\text{C}$	
	1.65	3	mA	$+85^{\circ}\text{C}$	
	2.6	4.4	mA	$+125^{\circ}\text{C}$	
DC113	0.79	1.1	mA	$-40^{\circ}\text{C}$	3.3V AFPLLO = 100 MHz (AVCO = 400 MHz, PLLFBD = 50, APLLDIV1 = 4)
	0.84	1.4	mA	$+25^{\circ}\text{C}$	
	0.96	2.3	mA	$+85^{\circ}\text{C}$	
	1.93	3.6	mA	$+125^{\circ}\text{C}$	

**Note 1:** The APLL current will be the same if more than one PWM or DAC is run to the APLL clock. All parameters are characterized but not tested during manufacturing.

**TABLE 33-13: ADC DELTA CURRENT<sup>(1)</sup>**

<b>Operating Conditions: 3.0V to 3.6V (unless otherwise stated)</b>					
Operating temperature $-40^{\circ}\text{C} \leq T_A \leq +85^{\circ}\text{C}$ for Industrial $-40^{\circ}\text{C} \leq T_A \leq +125^{\circ}\text{C}$ for Extended					
Parameter No.	Typ.	Max.	Units	Conditions	
DC120	3.61	4	mA	$-40^{\circ}\text{C}$	3.3V TAD = 14.3 ns (3.5 Msps conversion rate)
	3.68	4.1	mA	$+25^{\circ}\text{C}$	
	3.69	4.2	mA	$+85^{\circ}\text{C}$	
	3.89	4.6	mA	$+125^{\circ}\text{C}$	

**Note 1:** Shared core continuous conversion. TAD = 14.3 nS (3.5 Msps conversion rate). Listed delta currents are for only one ADC core. All parameters are characterized but not tested during manufacturing.



# dsPIC33CK256MP508 FAMILY

**TABLE 33-14: COMPARATOR + DAC DELTA CURRENT**

Operating Conditions: 3.0V to 3.6V (unless otherwise stated)					
Operating temperature -40°C ≤ TA ≤ +85°C for Industrial					
-40°C ≤ TA ≤ +125°C for Extended					
Parameter No.	Typ.	Max.	Units	Conditions	
DC130	1.2	1.35	mA	-40°C	3.3V AFPLLO @ 500 MHz <sup>(1)</sup>
	1.23	1.65	mA	+25°C	
	1.23	1.65	mA	+85°C	
	1.24	1.65	mA	+125°C	

**Note 1:** APLL current is not included. Listed delta currents are for only one comparator + DAC instance. All parameters are characterized but not tested during manufacturing.

**TABLE 33-15: OP AMP DELTA CURRENT<sup>(1)</sup>**

Operating Conditions: 3.0V to 3.6V (unless otherwise stated)					
Operating temperature -40°C ≤ TA ≤ +85°C for Industrial					
-40°C ≤ TA ≤ +125°C for Extended					
Parameter No.	Typ.	Max.	Units	Conditions	
DC140	0.25	1	mA	-40°C	3.3V
	0.27	1.1	mA	+25°C	
	0.32	1.4	mA	+85°C	
	0.46	1.7	mA	+125°C	

**Note 1:** Listed delta currents are for only one op amp instance. All parameters are characterized but not tested during manufacturing.

# dsPIC33CK256MP508 FAMILY

**TABLE 33-16: I/O PIN INPUT SPECIFICATIONS**

Operating Conditions: 3.0V to 3.6V (unless otherwise stated)							
Operating temperature $-40^{\circ}\text{C} \leq T_A \leq +85^{\circ}\text{C}$ for Industrial							
$-40^{\circ}\text{C} \leq T_A \leq +125^{\circ}\text{C}$ for Extended							
Param No.	Symbol	Characteristic	Min. <sup>(5)</sup>	Typ. <sup>(1)</sup>	Max. <sup>(6)</sup>	Units	Conditions
DI10	V <sub>IL</sub>	<b>Input Low Voltage</b>					
		Any I/O Pin and $\overline{\text{MCLR}}$	V <sub>SS</sub>	—	0.2 V <sub>DD</sub>	V	
		I/O Pins with SDAx, SCLx	V <sub>SS</sub>	—	0.3 V <sub>DD</sub>	V	SMBus disabled
		I/O Pins with SDAx, SCLx	V <sub>SS</sub>	—	0.8	V	SMBus enabled
		I/O Pins with SDAx, SCLx	V <sub>SS</sub>	—	0.8	V	SMBus 3.0 enabled
DI20	V <sub>IH</sub>	<b>Input High Voltage</b>					
		I/O Pins Not 5V Tolerant <sup>(3)</sup>	0.8 V <sub>DD</sub>	—	V <sub>DD</sub>	V	
		5V Tolerant I/O Pins and $\overline{\text{MCLR}}$ <sup>(3)</sup>	0.8 V <sub>DD</sub>	—	5.5	V	
		5V Tolerant I/O Pins with SDAx, SCLx <sup>(3)</sup>	0.8 V <sub>DD</sub>	—	5.5	V	SMBus disabled
		5V Tolerant I/O Pins with SDAx, SCLx <sup>(3)</sup>	2.1	—	5.5	V	SMBus enabled
		I/O Pins with SDAx, SCLx Not 5V Tolerant <sup>(3)</sup>	0.8 V <sub>DD</sub>	—	V <sub>DD</sub>	V	SMBus disabled
		I/O Pins with SDAx, SCLx Not 5V Tolerant <sup>(3)</sup>	2.1	—	V <sub>DD</sub>	V	SMBus enabled
I/O Pins with SDAx, SCLx Not 5V Tolerant	1.35	—	V <sub>DD</sub>	V	SMBus 3.0 enabled		
DI30	ICNPU	<b>Input Change Notification Pull-up Current<sup>(2,4)</sup></b>	175	360	545	μA	V <sub>DD</sub> = 3.6V, V <sub>PIN</sub> = V <sub>SS</sub>
DI31	ICNPD	<b>Input Change Notification Pull-Down Current<sup>(4)</sup></b>	65	215	360	μA	V <sub>DD</sub> = 3.6V, V <sub>PIN</sub> = V <sub>DD</sub>
DI50	I <sub>IL</sub>	<b>Input Leakage Current<sup>(2)</sup></b>					
		I/O Pins 5V Tolerant <sup>(3)</sup>	-700	—	700	nA	
		I/O Pins Not 5V Tolerant <sup>(3)</sup>	-700	—	700	nA	
		$\overline{\text{MCLR}}$	-700	—	700	nA	
		OSCI	-700	—	700	nA	XT and HS modes

**Note 1:** Data in the “Typ.” column are at 3.3V, +25°C unless otherwise stated.

**2:** Negative current is defined as current sourced by the pin.

**3:** See the “Pin Diagrams” section for the 5V tolerant I/O pins.

**4:** Characterized but not tested.

**5:** V<sub>PIN</sub> = V<sub>SS</sub>.

**6:** V<sub>PIN</sub> = V<sub>DD</sub>.

# dsPIC33CK256MP508 FAMILY

**TABLE 33-17: I/O PIN INPUT INJECTION CURRENT SPECIFICATIONS**

Operating Conditions: 3.0V to 3.6V (unless otherwise stated)						
Operating temperature $-40^{\circ}\text{C} \leq T_A \leq +85^{\circ}\text{C}$ for Industrial						
$-40^{\circ}\text{C} \leq T_A \leq +125^{\circ}\text{C}$ for Extended						
Param No.	Symbol	Characteristic	Min.	Max.	Units	Conditions
DI60a	IICL	Input Low Injection Current	0	-5 <sup>(1,4)</sup>	mA	All pins
DI60b	IICH	Input High Injection Current	0	+5 <sup>(2,3,4)</sup>	mA	All pins, except all 5V tolerant pins and SOSC1
DI60c	$\Sigma\text{IICT}$	Total Input Injection Current (sum of all I/O and control pins) <sup>(5)</sup>	-20	+20	mA	Absolute instantaneous sum of all $\pm$ input injection currents from all I/O pins ( $  \text{IICL}   +   \text{IICH}  $ ) $\leq \Sigma\text{IICT}$

**Note 1:**  $V_{IL}$  Source  $< (V_{SS} - 0.3)$ .

**2:**  $V_{IH}$  Source  $> (V_{DD} + 0.3)$  for non-5V tolerant pins only.

**3:** 5V tolerant pins do not have an internal high-side diode to  $V_{DD}$ , and therefore, cannot tolerate any “positive” input injection current.

**4:** Injection currents can affect the ADC results.

**5:** Any number and/or combination of I/O pins, not excluded under IICL or IICH conditions, are permitted in the sum.

**TABLE 33-18: I/O PIN OUTPUT SPECIFICATIONS**

Operating Conditions: 3.0V to 3.6V (unless otherwise stated)							
Operating temperature $-40^{\circ}\text{C} \leq T_A \leq +85^{\circ}\text{C}$ for Industrial							
$-40^{\circ}\text{C} \leq T_A \leq +125^{\circ}\text{C}$ for Extended							
Param.	Symbol	Characteristic	Min.	Typ.	Max.	Units	Conditions
DO10	VOL	Output Low Voltage 4x Sink Driver Pins	—	—	0.42	V	$V_{DD} = 3.6\text{V}$ , $I_{OL} < 9\text{ mA}$
		Output Low Voltage 8x Sink Driver Pins <sup>(1)</sup>	—	—	0.4	V	$V_{DD} = 3.6\text{V}$ , $I_{OL} < 11\text{ mA}$
DO20	VOH	Output High Voltage 4x Source Driver Pins	2.4	—	—	V	$V_{DD} = 3.6\text{V}$ , $I_{OH} > -8\text{ mA}$
		Output High Voltage 8x Source Driver Pins <sup>(1)</sup>	2.4	—	—	V	$V_{DD} = 3.6\text{V}$ , $I_{OH} > -12\text{ mA}$

**Note 1:** The 8x sink/source pins are RB1, RC8, RC9 and RD8.

# dsPIC33CK256MP508 FAMILY

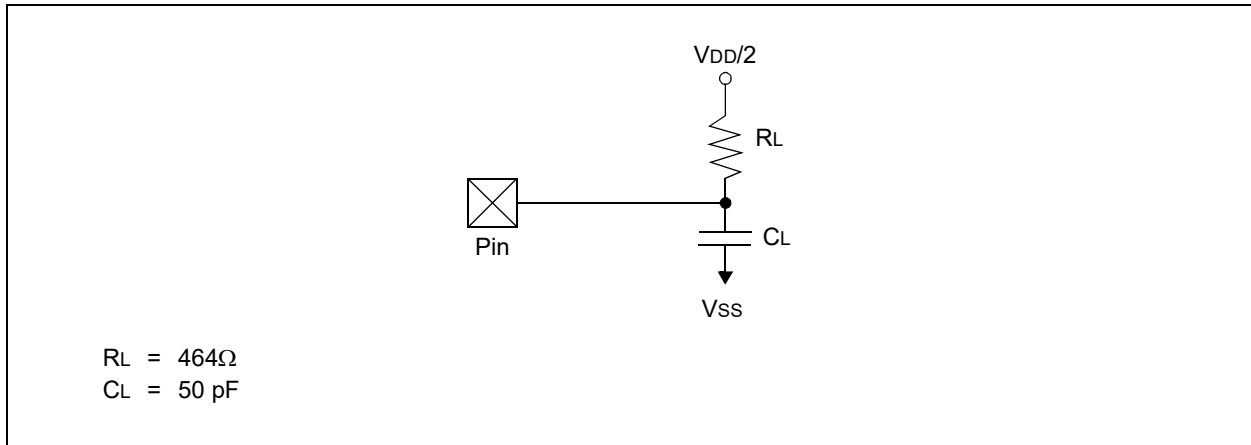
**TABLE 33-19: PROGRAM MEMORY**

Operating Conditions: 3.0V to 3.6V (unless otherwise stated)						
Operating temperature $-40^{\circ}\text{C} \leq T_A \leq +85^{\circ}\text{C}$ for Industrial $-40^{\circ}\text{C} \leq T_A \leq +125^{\circ}\text{C}$ for Extended						
Param No.	Symbol	Characteristic	Min.	Max.	Units	Conditions
<b>Program Flash Memory</b>						
D130	EP	Cell Endurance	10,000	—	E/W	$-40^{\circ}\text{C}$ to $+125^{\circ}\text{C}$
D131	VPR	VDD for Read	3.0	3.6	V	
D132b	VPEW	VDD for Self-Timed Write	3.0	3.6	V	
D134	TRETD	Characteristic Retention	20	—	Year	Provided no other specifications are violated, $-40^{\circ}\text{C}$ to $+125^{\circ}\text{C}$
D137a	TPE	Page Erase Time	15.3	16.82	ms	TPE = 128,454 FRC cycles ( <b>Note 1</b> )
D138a	TWW	Word Write Time	47.7	52.3	$\mu\text{s}$	TWW = 400 FRC cycles ( <b>Note 1</b> )
D139a	TRW	Row Write Time	2.0	2.2	ms	TRW = 16,782 FRC cycles ( <b>Note 1</b> )

**Note 1:** Other conditions: FRC = 8 MHz, TUN[5:0] = 011111 (for Minimum), TUN[5:0] = 100000 (for Maximum). This parameter depends on the FRC accuracy (see [Table 33-23](#)) and the value of the FRC Oscillator Tuning register (see [Register 9-4](#)). For complete details on calculating the Minimum and Maximum time, see [Section 5.3 “Programming Operations”](#).

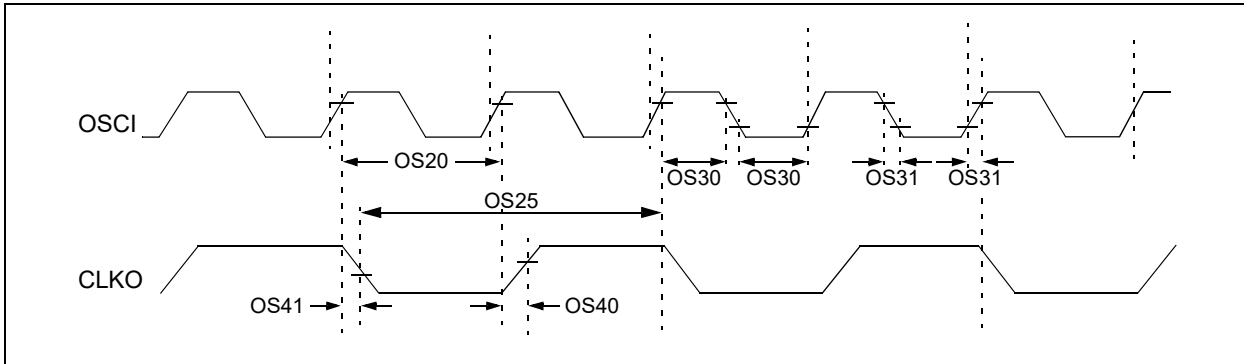
## 33.2 AC Characteristics and Timing Parameters

FIGURE 33-1: LOAD CONDITIONS FOR I/O SPECIFICATIONS



# dsPIC33CK256MP508 FAMILY

**FIGURE 33-2: EXTERNAL CLOCK TIMING**



**TABLE 33-20: EXTERNAL CLOCK TIMING REQUIREMENTS**

Operating Conditions: 3.0V to 3.6V (unless otherwise stated)							
Operating temperature $-40^{\circ}\text{C} \leq T_A \leq +85^{\circ}\text{C}$ for Industrial							
$-40^{\circ}\text{C} \leq T_A \leq +125^{\circ}\text{C}$ for Extended							
Param No.	Sym	Characteristic	Min.	Typ. <sup>(1)</sup>	Max.	Units	Conditions
OS10	FIN	External CLKI Frequency	DC	—	64	MHz	
		Oscillator Crystal Frequency	3.5	—	10	MHz	XT
			10	—	32	MHz	HS
OS20	Tosci	External Clock Period	15.63	—	DC	ns	
OS25	Tcy	Instruction Cycle Time	10	—	DC	ns	
OS30	TosL, TosH	External Clock in (OSCI) High or Low Time	$0.45 \times T_{osc}$	—	$0.55 \times T_{osc}$	ns	
OS31	TosR, TosF	External Clock in (OSCI) Rise or Fall Time	—	—	5.2	ns	When FIN = 64 MHz
OS40	TckR	CLKO Rise Time <sup>(2,3)</sup>	—	5.4	—	ns	
OS41	TckF	CLKO Fall Time <sup>(2,3)</sup>	—	6.4	—	ns	
OS42	GM	External Oscillator Transconductance <sup>(3)</sup>	2.7	—	4	mA/V	XTCFG[1:0] = 00, XTBST = 0
			4	—	7	mA/V	XTCFG[1:0] = 00, XTBST = 1
			4.5	—	7	mA/V	XTCFG[1:0] = 01, XTBST = 0
			6	—	11.9	mA/V	XTCFG[1:0] = 01, XTBST = 1
			5.9	—	9.7	mA/V	XTCFG[1:0] = 10, XTBST = 0
			6.9	—	15.9	mA/V	XTCFG[1:0] = 10, XTBST = 1
			6.7	—	12	mA/V	XTCFG[1:0] = 11, XTBST = 0
			7.5	—	19	mA/V	XTCFG[1:0] = 11, XTBST = 1

**Note 1:** Data in the "Typ." column are at 3.3V, +25°C unless otherwise stated.

**Note 2:** Measurements are taken in EC mode. The CLKO signal is measured on the OSCO pin.

**Note 3:** This parameter is characterized but not tested in manufacturing.

# dsPIC33CK256MP508 FAMILY

**TABLE 33-21: PLL TIMING SPECIFICATIONS**

Operating Conditions: 3.0V to 3.6V (unless otherwise stated)							
Operating temperature $-40^{\circ}\text{C} \leq T_A \leq +85^{\circ}\text{C}$ for Industrial							
$-40^{\circ}\text{C} \leq T_A \leq +125^{\circ}\text{C}$ for Extended							
Param No.	Symbol	Characteristic	Min.	Typ. <sup>(1)</sup>	Max.	Units	Conditions
OS50	FPLLI	PLL Voltage Controlled Oscillator (VCO) Input Frequency Range	8 <sup>(2)</sup>	—	64	MHz	ECPLL, XTPLL modes
OS51	FVCO	On-Chip VCO System Frequency	400	—	1600	MHz	
OS52	TLOCK	PLL Start-up Time (Lock Time)	—	125	—	$\mu\text{s}$	

**Note 1:** Data in the “Typ.” column are at 3.3V, +25°C unless otherwise stated. Parameters are for design guidance only and are not tested.

**2:** Inclusive of FRC Tolerance Specification F20a.

**TABLE 33-22: AUXILIARY PLL TIMING SPECIFICATIONS**

Operating Conditions: 3.0V to 3.6V (unless otherwise stated)							
Operating temperature $-40^{\circ}\text{C} \leq T_A \leq +85^{\circ}\text{C}$ for Industrial							
$-40^{\circ}\text{C} \leq T_A \leq +125^{\circ}\text{C}$ for Extended							
Param No.	Symbol	Characteristic	Min.	Typ. <sup>(1)</sup>	Max.	Units	Conditions
OS50	AFPLLI	APLL Voltage Controlled Oscillator (VCO) Input Frequency Range	8 <sup>(2)</sup>	—	64	MHz	ECPLL, XTPLL modes
OS51	AFVCO	On-Chip VCO System Frequency	400	—	1600	MHz	
OS52	TLOCK	APLL Start-up Time (Lock Time)	—	125	—	$\mu\text{s}$	

**Note 1:** Data in the “Typ.” column are at 3.3V, +25°C unless otherwise stated. Parameters are for design guidance only and are not tested.

**2:** Inclusive of FRC Tolerance Specification F20a.

# dsPIC33CK256MP508 FAMILY

**TABLE 33-23: INTERNAL FRC ACCURACY**

Operating Conditions: 3.0V to 3.6V (unless otherwise stated)					
Operating temperature -40°C ≤ TA ≤ +85°C for Industrial					
-40°C ≤ TA ≤ +125°C for Extended					
Param No.	Characteristic	Min.	Max.	Units	Conditions
<b>Internal FRC Accuracy @ FRC Frequency = 8 MHz<sup>(1)</sup></b>					
F20a	FRC	-2 <sup>(2)</sup>	+2	%	-40°C ≤ TA ≤ -5°C
		-1.5	+1.5	%	-5°C ≤ TA ≤ +85°C
		-2	+2	%	+85°C ≤ TA ≤ +125°C
F22	BFRC	-17	+17	%	-40°C ≤ TA ≤ +125°C

**Note 1:** Frequency is calibrated at +25°C and 3.3V.

**Note 2:** Due to the effect of aging, this value may drift by an additional -0.5% over the lifetime of the device.

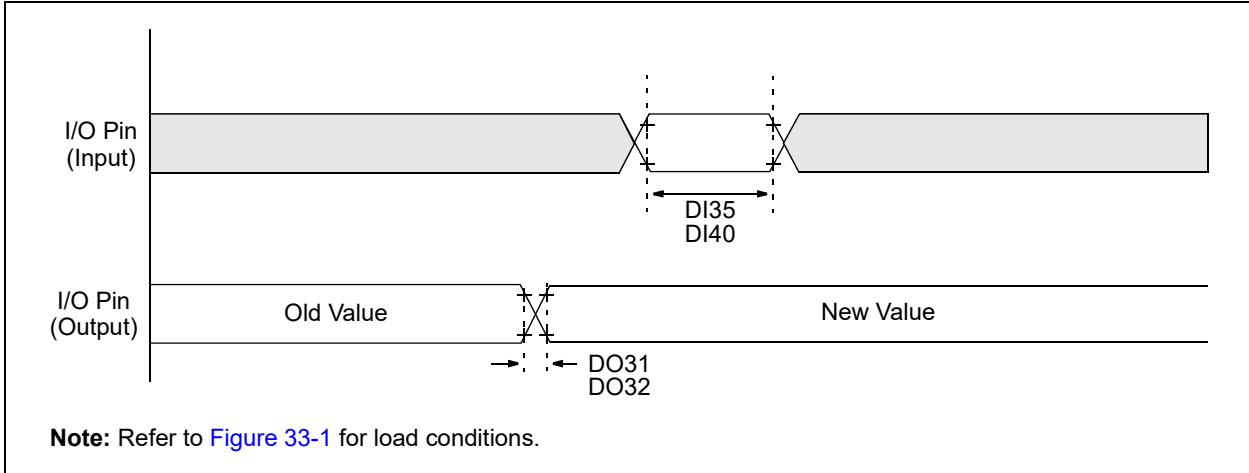
**TABLE 33-24: INTERNAL LPRC ACCURACY**

Operating Conditions: 3.0V to 3.6V (unless otherwise stated)					
Operating temperature -40°C ≤ TA ≤ +85°C for Industrial					
-40°C ≤ TA ≤ +125°C for Extended					
Param No.	Characteristic	Min.	Max.	Units	Conditions
<b>LPRC @ 32 kHz</b>					
F21	LPRC	-25	+25	%	-40°C ≤ TA ≤ 0°C
		-10	+10	%	0°C ≤ TA ≤ +85°C
		-15	+15	%	+85°C ≤ TA ≤ +125°C



# dsPIC33CK256MP508 FAMILY

**FIGURE 33-3: I/O TIMING CHARACTERISTICS**



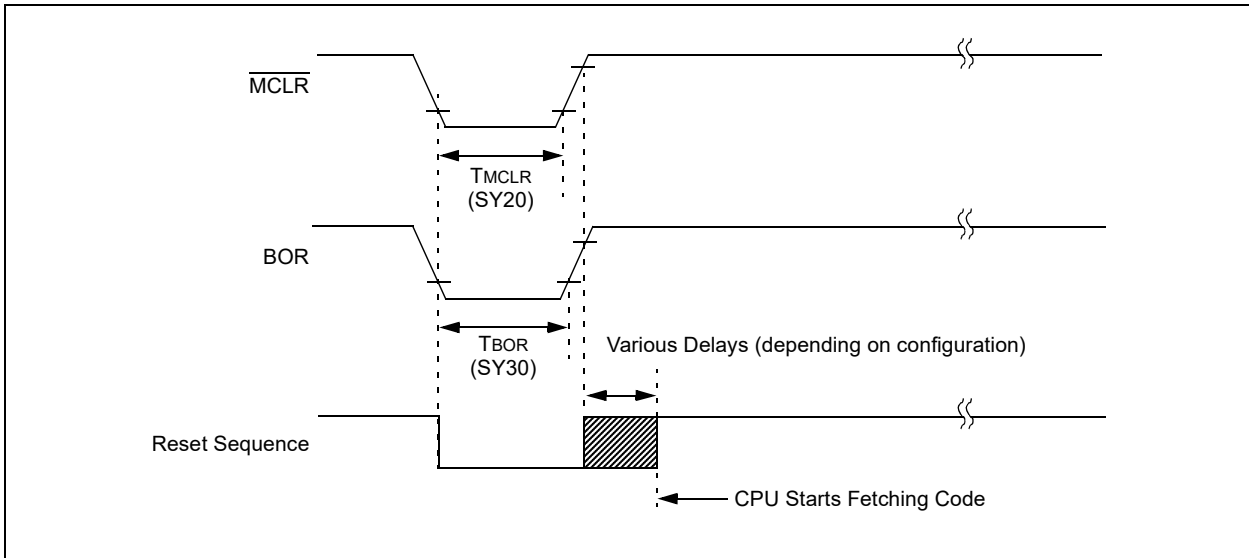
**TABLE 33-25: I/O TIMING REQUIREMENTS**

**Operating Conditions: 3.0V to 3.6V (unless otherwise stated)**  
 Operating temperature  $-40^{\circ}\text{C} \leq T_A \leq +85^{\circ}\text{C}$  for Industrial  
 $-40^{\circ}\text{C} \leq T_A \leq +125^{\circ}\text{C}$  for Extended

Param No.	Symbol	Characteristic	Min.	Typ. <sup>(1)</sup>	Max.	Units	Conditions
DO31	T <sub>IO</sub> R	Port Output Rise Time <sup>(2)</sup>	—	6.5	9.7	ns	
DO32	T <sub>IO</sub> F	Port Output Fall Time <sup>(2)</sup>	—	3.2	4.2	ns	
DI35	T <sub>INP</sub>	INTx Pin High or Low Time (input)	20	—	—	ns	
DI40	TRBP	CNx High or Low Time (input)	2	—	—	T <sub>CY</sub>	

- Note 1:** Data in the “Typ.” column are at 3.3V, +25°C unless otherwise stated.  
**Note 2:** This parameter is characterized but not tested in manufacturing.

**FIGURE 33-4: BOR AND MASTER CLEAR RESET TIMING CHARACTERISTICS**



# dsPIC33CK256MP508 FAMILY

**TABLE 33-26: RESET, WATCHDOG TIMER, OSCILLATOR START-UP TIMER, TIMING REQUIREMENTS**

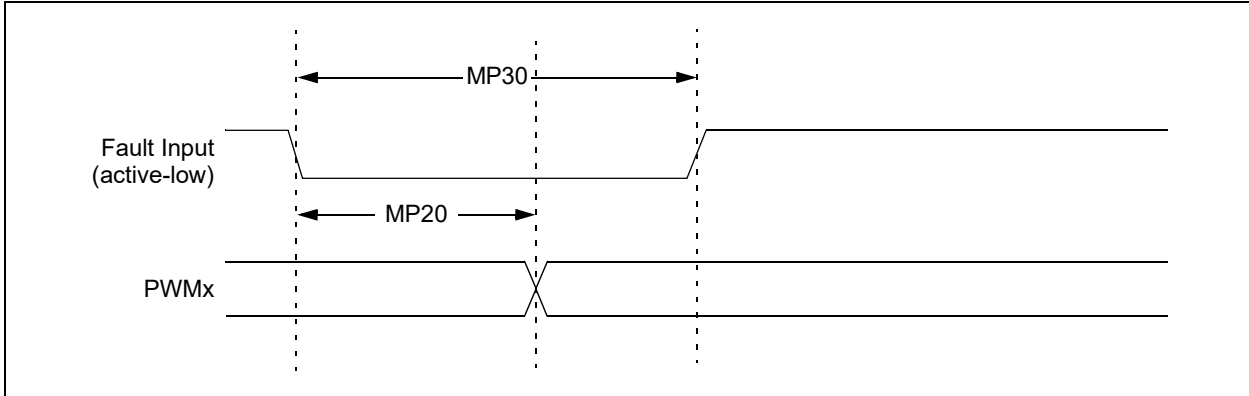
Operating Conditions: 3.0V to 3.6V (unless otherwise stated) Operating temperature $-40^{\circ}\text{C} \leq T_A \leq +85^{\circ}\text{C}$ for Industrial $-40^{\circ}\text{C} \leq T_A \leq +125^{\circ}\text{C}$ for Extended							
Param No.	Symbol	Characteristic <sup>(1)</sup>	Min.	Typ. <sup>(2)</sup>	Max.	Units	Conditions
SY00	TPU	Power-up Period	—	200	—	$\mu\text{s}$	FNOSC[2:0] are FRC
SY10	TOST	Oscillator Start-up Time	—	1024 TOSC	—	—	TOSC = OSCI period
SY13	TIOZ	I/O High-Impedance from MCLR Low or Watchdog Timer Reset	—	1.5	—	$\mu\text{s}$	
SY20	TMCLR	MCLR Pulse Width (low)	2	—	—	$\mu\text{s}$	
SY30	TBOR	BOR Pulse Width (low)	1	—	—	$\mu\text{s}$	
SY35	TFSCM	Fail-Safe Clock Monitor Delay	—	—	40	$\mu\text{s}$	Clock fail to BFRC switch
SY37	TOSCDFRC	FRC Oscillator Start-up Delay	—	—	15	$\mu\text{s}$	From POR event
SY38	TOSCDLPRC	LPRC Oscillator Start-up Delay	—	—	50	$\mu\text{s}$	From Reset event

**Note 1:** These parameters are characterized but not tested in manufacturing.

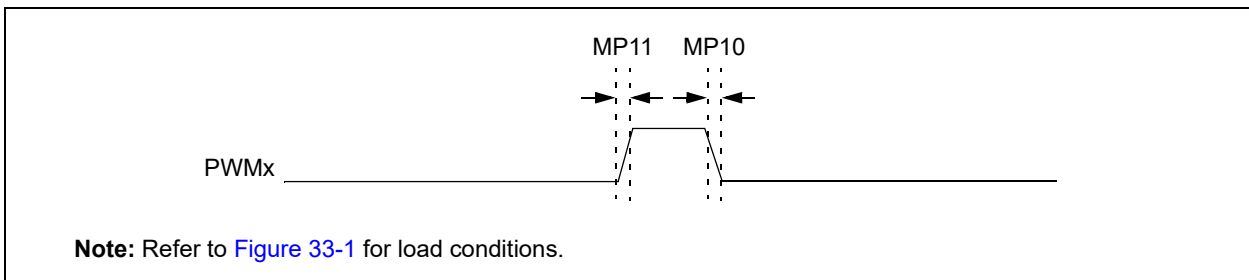
**2:** Data in the "Typ." column are at 3.3V, +25°C unless otherwise stated.

# dsPIC33CK256MP508 FAMILY

**FIGURE 33-5: HIGH-SPEED PWMx MODULE FAULT TIMING CHARACTERISTICS**



**FIGURE 33-6: HIGH-SPEED PWMx MODULE TIMING CHARACTERISTICS**



**TABLE 33-27: HIGH-SPEED PWMx MODULE TIMING REQUIREMENTS**

Operating Conditions: 3.0V to 3.6V (unless otherwise stated)						
Operating temperature $-40^{\circ}\text{C} \leq T_A \leq +85^{\circ}\text{C}$ for Industrial						
$-40^{\circ}\text{C} \leq T_A \leq +125^{\circ}\text{C}$ for Extended						
Param No.	Symbol	Characteristic <sup>(1)</sup>	Min.	Max.	Units	Conditions
MP00	FIN	PWM Input Frequency	450	500	MHz	<a href="#">Note 2</a>
MP10	TFPWM	PWMx Output Fall Time	—	—	ns	See Parameter <a href="#">DO32</a>
MP11	TRPWM	PWMx Output Rise Time	—	—	ns	See Parameter <a href="#">DO31</a>
MP20	TFD	Fault Input to PWMx I/O Change	—	26	ns	PCI Inputs 19 through 22
MP30	TFH	Fault Input Pulse Width	8	—	ns	

**Note 1:** These parameters are characterized but not tested in manufacturing.

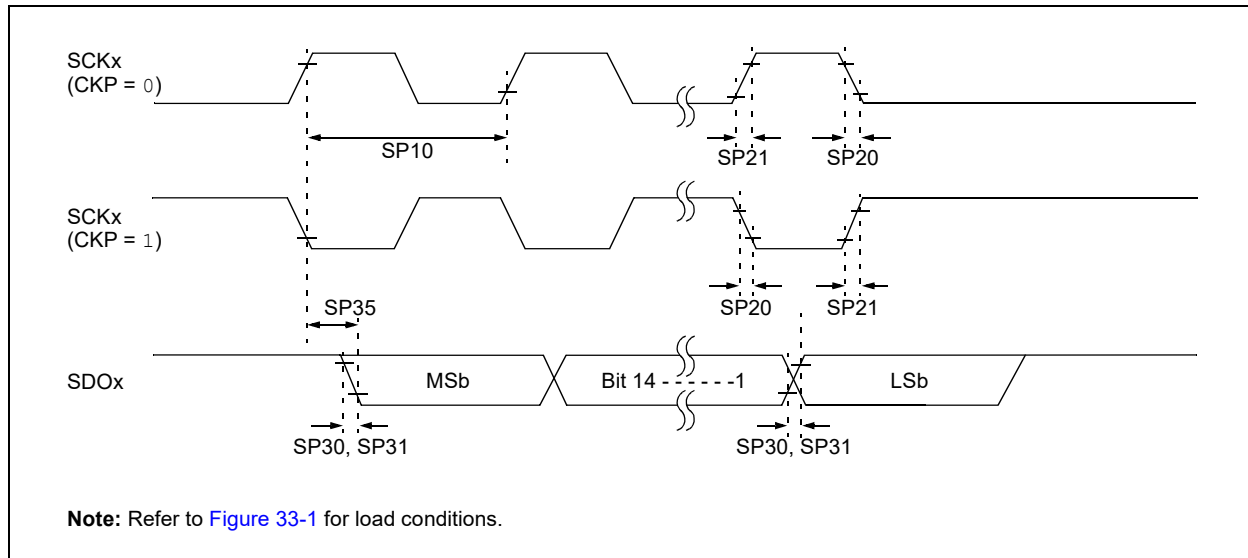
**Note 2:** Input frequency of 500 MHz is recommended for High-Resolution mode.

# dsPIC33CK256MP508 FAMILY

**TABLE 33-28: SPIx MAXIMUM DATA/CLOCK RATE SUMMARY**

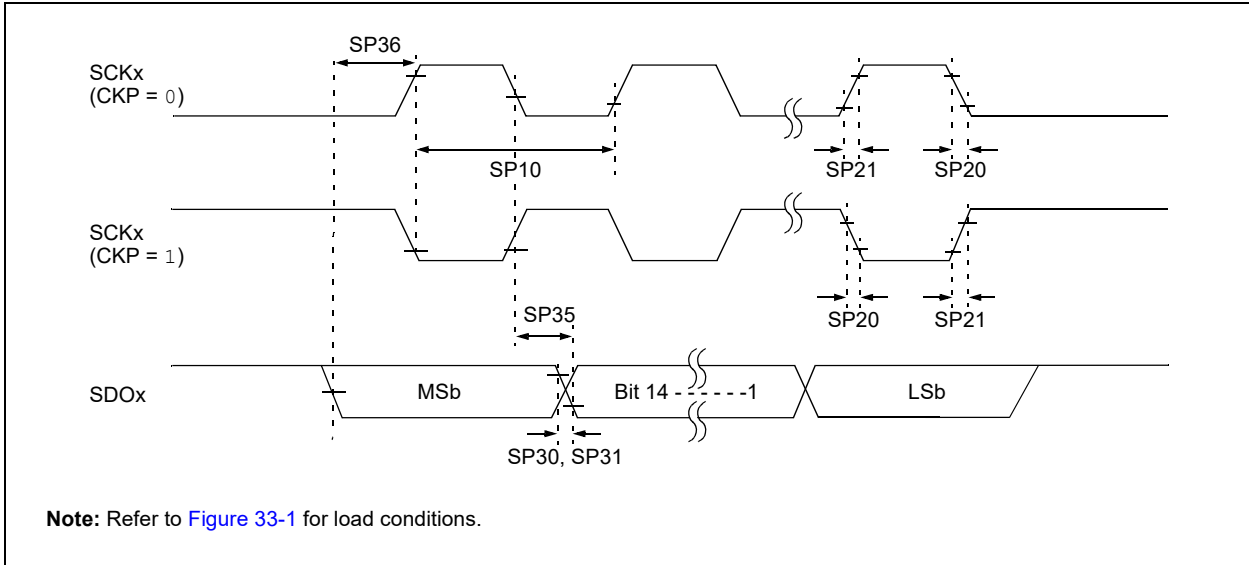
SPI Host Transmit Only (Half-Duplex)	SPI Host Transmit/Receive (Full-Duplex)	SPI Client Transmit/Receive (Full-Duplex)	CKE
Figure 33-7 Table 33-29	—	—	0
Figure 33-8 Table 33-29	—	—	1
—	Figure 33-9 Table 33-30	—	0
—	Figure 33-10 Table 33-31	—	1
—	—	Figure 33-11 Table 33-33	0
—	—	Figure 33-12 Table 33-34	1

**FIGURE 33-7: SPIx HOST MODE (HALF-DUPLEX, TRANSMIT ONLY, CKE = 0) TIMING CHARACTERISTICS**



# dsPIC33CK256MP508 FAMILY

**FIGURE 33-8: SPIx HOST MODE (HALF-DUPLEX, TRANSMIT ONLY, CKE = 1) TIMING CHARACTERISTICS**



**TABLE 33-29: SPIx HOST MODE (HALF-DUPLEX, TRANSMIT ONLY) TIMING REQUIREMENTS**

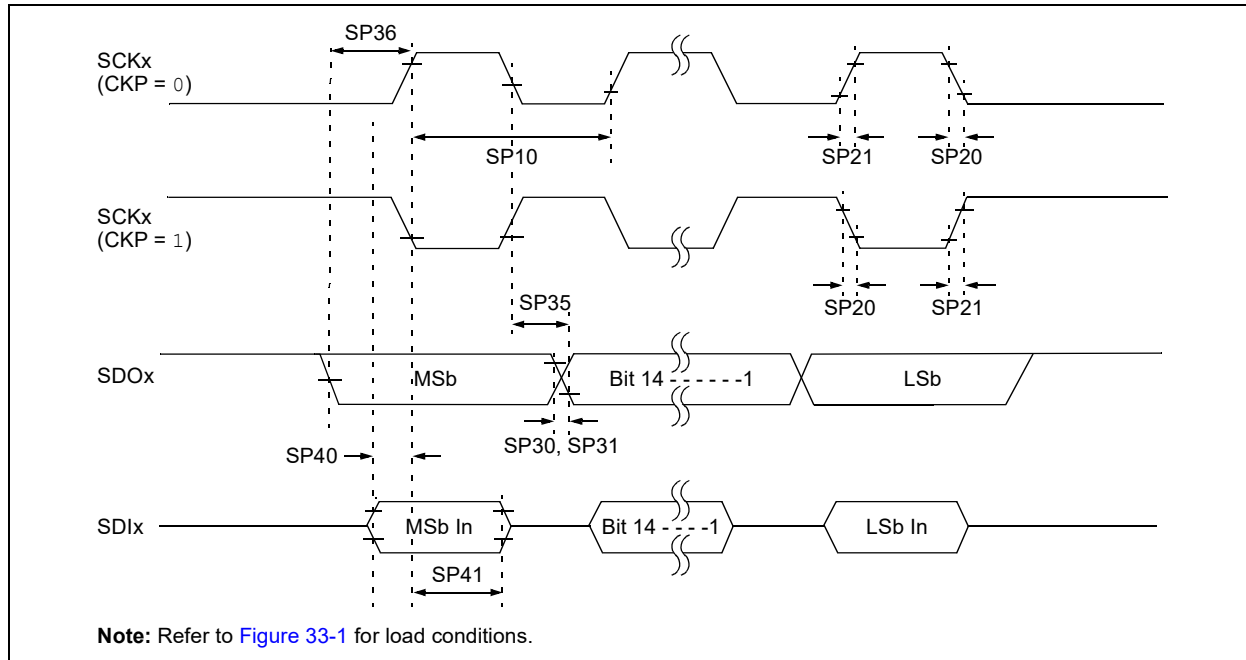
Operating Conditions: 3.0V to 3.6V (unless otherwise stated)							
Operating temperature $-40^{\circ}\text{C} \leq T_A \leq +85^{\circ}\text{C}$ for Industrial							
$-40^{\circ}\text{C} \leq T_A \leq +125^{\circ}\text{C}$ for Extended							
Param No.	Symbol	Characteristic <sup>(1)</sup>	Min.	Typ. <sup>(2)</sup>	Max.	Units	Conditions
SP10	FscP	Maximum SCKx Frequency	—	—	15	MHz	Using PPS pins
			—	—	40	MHz	SPIx dedicated pins
SP20	TscF	SCKx Output Fall Time	—	—	—	ns	See Parameter <a href="#">DO32</a>
SP21	TscR	SCKx Output Rise Time	—	—	—	ns	See Parameter <a href="#">DO31</a>
SP30	TdoF	SDOx Data Output Fall Time	—	—	—	ns	See Parameter <a href="#">DO32</a>
SP31	TdoR	SDOx Data Output Rise Time	—	—	—	ns	See Parameter <a href="#">DO31</a>
SP35	Tsch2doV, TscL2doV	SDOx Data Output Valid After SCKx Edge	—	6	20	ns	
SP36	TdiV2scH, TdiV2scL	SDOx Data Output Setup to First SCKx Edge	30	—	—	ns	Using PPS pins
			3	—	—	ns	SPIx dedicated pins

**Note 1:** These parameters are characterized but not tested in manufacturing.

**Note 2:** Data in the "Typ." column are at 3.3V, +25°C unless otherwise stated.

# dsPIC33CK256MP508 FAMILY

**FIGURE 33-9: SPIx HOST MODE (FULL-DUPLEX, CKE = 1, CKP = x, SMP = 1) TIMING CHARACTERISTICS**



**TABLE 33-30: SPIx HOST MODE (FULL-DUPLEX, CKE = 1, CKP = x, SMP = 1) TIMING REQUIREMENTS**

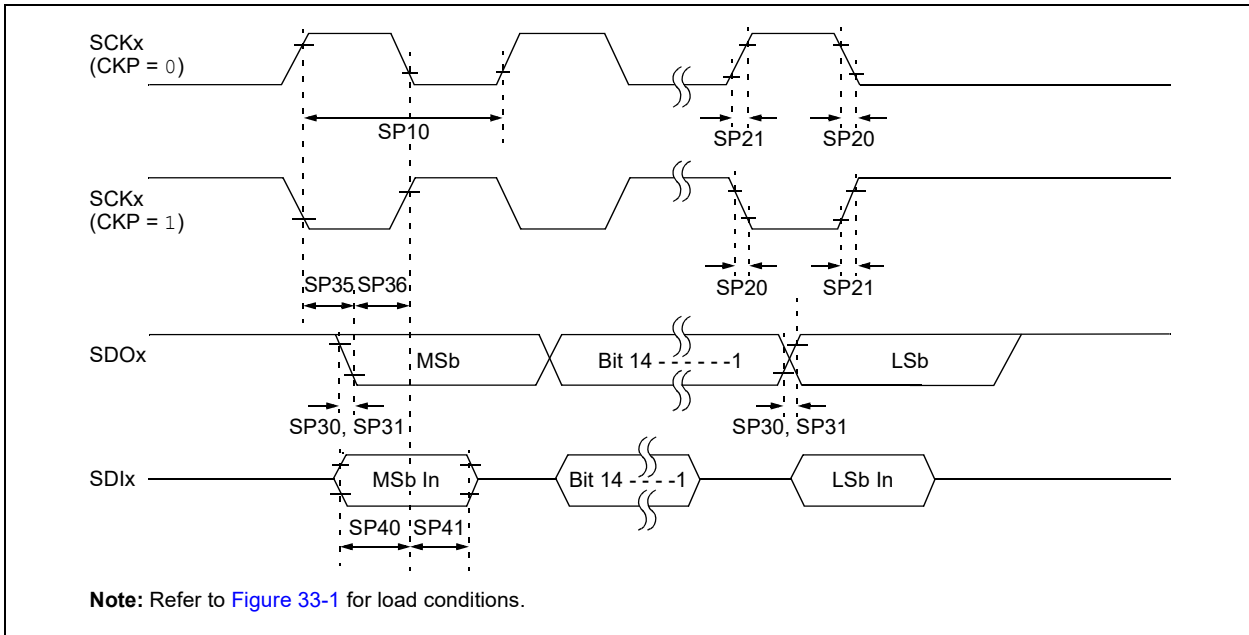
Operating Conditions: 3.0V to 3.6V (unless otherwise stated)							
Operating temperature $-40^{\circ}\text{C} \leq T_A \leq +85^{\circ}\text{C}$ for Industrial							
$-40^{\circ}\text{C} \leq T_A \leq +125^{\circ}\text{C}$ for Extended							
Param No.	Symbol	Characteristic <sup>(1)</sup>	Min.	Typ. <sup>(2)</sup>	Max.	Units	Conditions
SP10	FscP	Maximum SCKx Frequency	—	—	15	MHz	Using PPS pins
			—	—	40	MHz	SPIx dedicated pins
SP20	TscF	SCKx Output Fall Time	—	—	—	ns	See Parameter <a href="#">DO32</a>
SP21	TscR	SCKx Output Rise Time	—	—	—	ns	See Parameter <a href="#">DO31</a>
SP30	TdoF	SDOx Data Output Fall Time	—	—	—	ns	See Parameter <a href="#">DO32</a>
SP31	TdoR	SDOx Data Output Rise Time	—	—	—	ns	See Parameter <a href="#">DO31</a>
SP35	Tsch2doV, TscL2doV	SDOx Data Output Valid After SCKx Edge	—	6	20	ns	
SP36	TdoV2sc, TdoV2scL	SDOx Data Output Setup to First SCKx Edge	30	—	—	ns	Using PPS pins
			3	—	—	ns	SPIx dedicated pins
SP40	TdiV2sch, TdiV2scL	Setup Time of SDIx Data Input to SCKx Edge	30	—	—	ns	Using PPS pins
			10	—	—	ns	SPIx dedicated pins
SP41	Tsch2diL, TscL2diL	Hold Time of SDIx Data Input to SCKx Edge	30	—	—	ns	Using PPS pins
			15	—	—	ns	SPIx dedicated pins

**Note 1:** These parameters are characterized but not tested in manufacturing.

**Note 2:** Data in the "Typ." column are at 3.3V, +25°C unless otherwise stated.

# dsPIC33CK256MP508 FAMILY

**FIGURE 33-10: SPIx HOST MODE (FULL-DUPLEX, CKE = 0, CKP = x, SMP = 1) TIMING CHARACTERISTICS**



**TABLE 33-31: SPIx HOST MODE (FULL-DUPLEX, CKE = 0, CKP = x, SMP = 1) TIMING REQUIREMENTS**

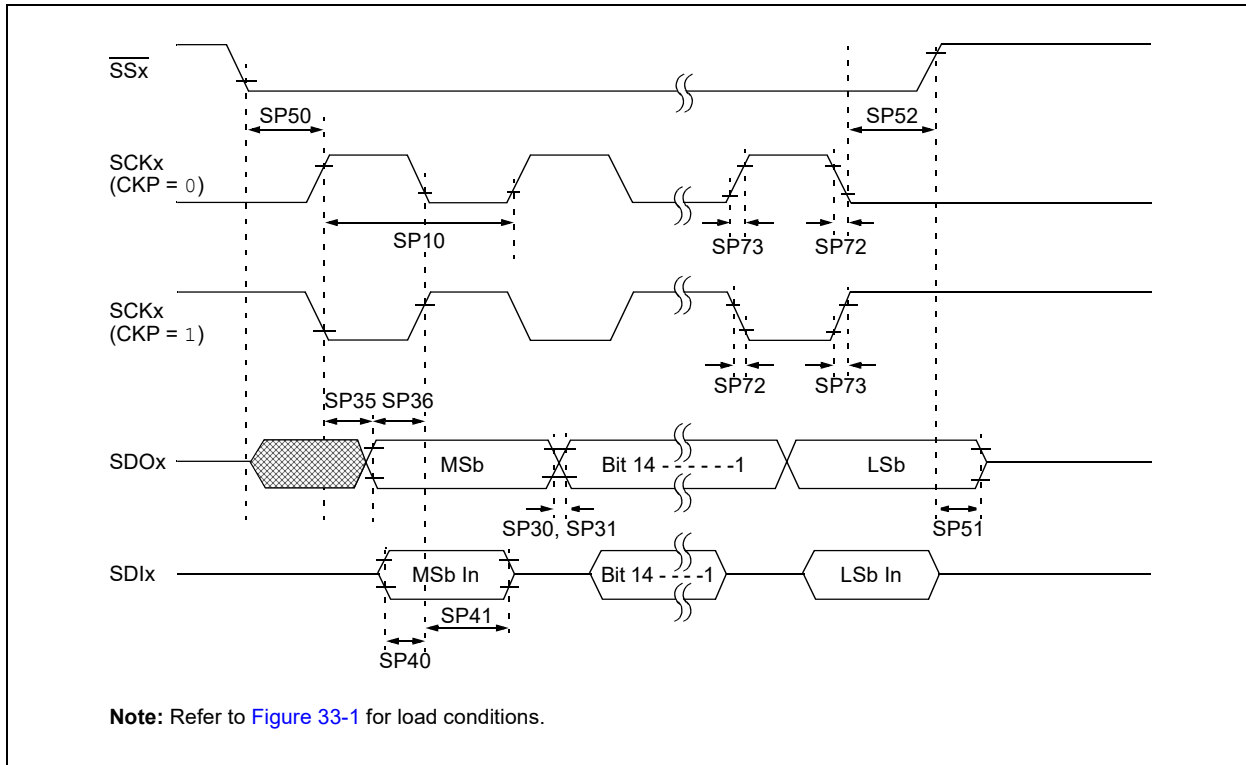
Operating Conditions: 3.0V to 3.6V (unless otherwise stated)							
Operating temperature $-40^{\circ}\text{C} \leq T_A \leq +85^{\circ}\text{C}$ for Industrial							
$-40^{\circ}\text{C} \leq T_A \leq +125^{\circ}\text{C}$ for Extended							
Param No.	Symbol	Characteristic <sup>(1)</sup>	Min.	Typ. <sup>(2)</sup>	Max.	Units	Conditions
SP10	FscP	Maximum SCKx Frequency	—	—	15	MHz	Using PPS pins
			—	—	40	MHz	SPIx dedicated pins
SP20	TscF	SCKx Output Fall Time	—	—	—	ns	See Parameter <a href="#">DO32</a>
SP21	TscR	SCKx Output Rise Time	—	—	—	ns	See Parameter <a href="#">DO31</a>
SP30	TdoF	SDOx Data Output Fall Time	—	—	—	ns	See Parameter <a href="#">DO32</a>
SP31	TdoR	SDOx Data Output Rise Time	—	—	—	ns	See Parameter <a href="#">DO31</a>
SP35	Tsch2doV, TscL2doV	SDOx Data Output Valid After SCKx Edge	—	6	20	ns	
SP36	TdoV2sch, TdoV2scl	SDOx Data Output Setup to First SCKx Edge	30	—	—	ns	Using PPS pins
			20	—	—	ns	SPIx dedicated pins
SP40	TdiV2sch, TdiV2scl	Setup Time of SDIx Data Input to SCKx Edge	30	—	—	ns	Using PPS pins
			10	—	—	ns	SPIx dedicated pins
SP41	Tsch2diL, TscL2diL	Hold Time of SDIx Data Input to SCKx Edge	30	—	—	ns	Using PPS pins
			15	—	—	ns	SPIx dedicated pins

**Note 1:** These parameters are characterized but not tested in manufacturing.

**Note 2:** Data in the "Typ." column are at 3.3V, +25°C unless otherwise stated.

# dsPIC33CK256MP508 FAMILY

**FIGURE 33-11: SPIx CLIENT MODE (FULL-DUPLEX, CKE = 0, CKP = x, SMP = 0) TIMING CHARACTERISTICS**





# dsPIC33CK256MP508 FAMILY

**TABLE 33-32: SPIx CLIENT MODE (FULL-DUPLEX, CKE = 0, CKP = x, SMP = 0)  
TIMING REQUIREMENTS**

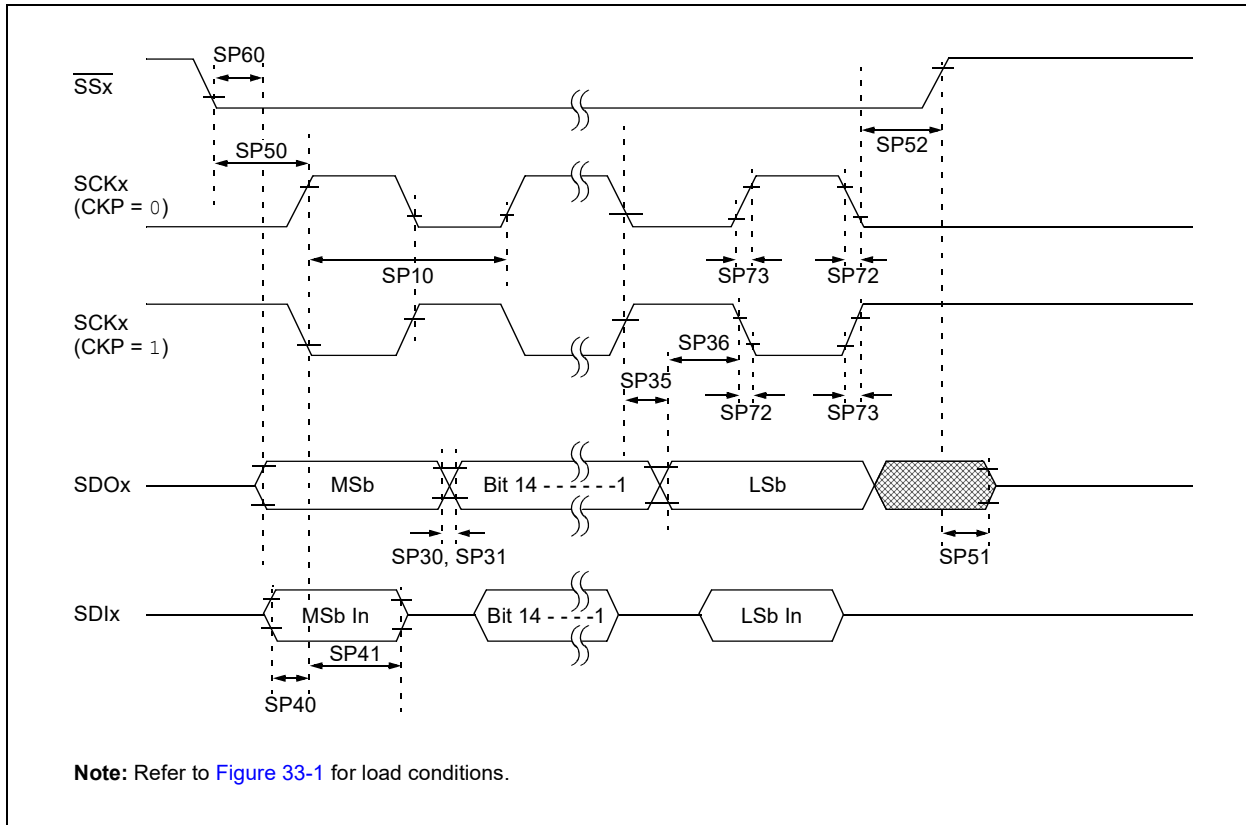
Operating Conditions: 3.0V to 3.6V (unless otherwise stated)							
Operating temperature $-40^{\circ}\text{C} \leq T_A \leq +85^{\circ}\text{C}$ for Industrial							
$-40^{\circ}\text{C} \leq T_A \leq +125^{\circ}\text{C}$ for Extended							
Param No.	Symbol	Characteristic <sup>(1)</sup>	Min.	Typ. <sup>(2)</sup>	Max.	Units	Conditions
SP10	FscP	Maximum SCKx Input Frequency	—	—	15	MHz	Using PPS pins
			—	—	40	MHz	SPIx dedicated pins
SP72	TscF	SCKx Input Fall Time	—	—	—	ns	See Parameter <a href="#">DO32</a>
SP73	TscR	SCKx Input Rise Time	—	—	—	ns	See Parameter <a href="#">DO31</a>
SP30	TdoF	SDOx Data Output Fall Time	—	—	—	ns	See Parameter <a href="#">DO32</a>
SP31	TdoR	SDOx Data Output Rise Time	—	—	—	ns	See Parameter <a href="#">DO31</a>
SP35	TscH2doV, TscL2doV	SDOx Data Output Valid After SCKx Edge	—	6	20	ns	
SP36	TdoV2scH, TdoV2scL	SDOx Data Output Setup to First SCKx Edge	30	—	—	ns	Using PPS pins
			20	—	—	ns	SPIx dedicated pins
SP40	TdiV2scH, TdiV2scL	Setup Time of SDIx Data Input to SCKx Edge	30	—	—	ns	Using PPS pins
			10	—	—	ns	SPIx dedicated pins
SP41	Tsch2diL, TscL2diL	Hold Time of SDIx Data Input to SCKx Edge	30	—	—	ns	Using PPS pins
			15	—	—	ns	SPIx dedicated pins
SP50	TssL2scH, TssL2scL	$\overline{\text{SS}}_x \downarrow$ to SCKx $\uparrow$ or SCKx $\downarrow$ Input	120	—	—	ns	
SP51	TssH2doZ	$\overline{\text{SS}}_x \uparrow$ to SDOx Output High-Impedance	8	—	50	ns	
SP52	Tsch2ssH, TscL2ssH	$\overline{\text{SS}}_x \uparrow$ After SCKx Edge	$1.5 T_{CY} + 40$	—	—	ns	

**Note 1:** These parameters are characterized but not tested in manufacturing.

**2:** Data in the “Typ.” column are at 3.3V, +25°C unless otherwise stated.

# dsPIC33CK256MP508 FAMILY

**FIGURE 33-12: SPIx CLIENT MODE (FULL-DUPLEX, CKE = 1, CKP = x, SMP = 0) TIMING CHARACTERISTICS**



# dsPIC33CK256MP508 FAMILY

**TABLE 33-33: SPIx CLIENT MODE (FULL-DUPLEX, CKE = 1, CKP = x, SMP = 0)  
TIMING REQUIREMENTS**

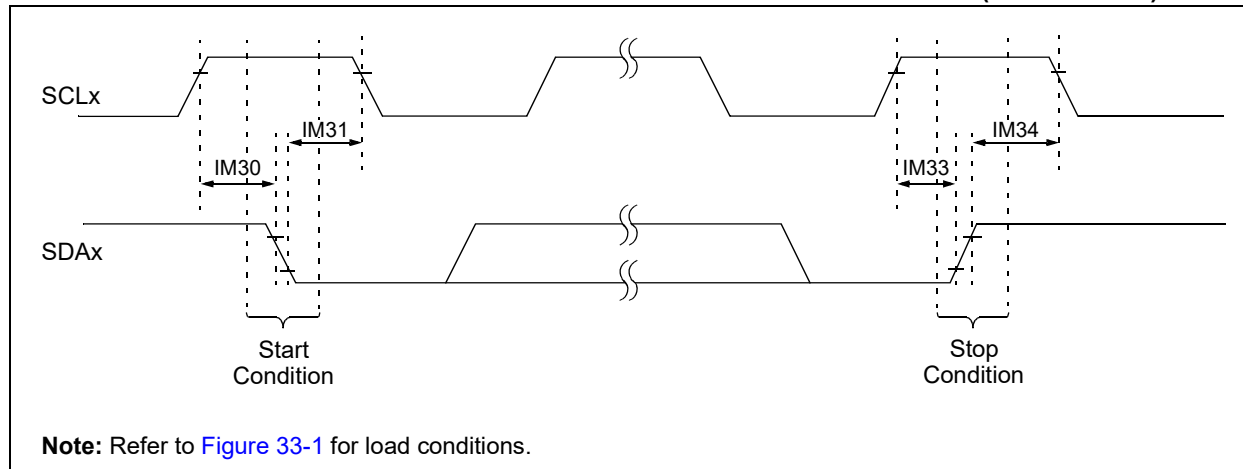
Operating Conditions: 3.0V to 3.6V (unless otherwise stated)							
Operating temperature $-40^{\circ}\text{C} \leq T_A \leq +85^{\circ}\text{C}$ for Industrial							
$-40^{\circ}\text{C} \leq T_A \leq +125^{\circ}\text{C}$ for Extended							
Param No.	Symbol	Characteristic <sup>(1)</sup>	Min.	Typ. <sup>(2)</sup>	Max.	Units	Conditions
SP10	FscP	Maximum SCKx Input Frequency	—	—	15	MHz	Using PPS pins
			—	—	40	MHz	SPIx dedicated pins
SP72	TscF	SCKx Input Fall Time	—	—	—	ns	See Parameter <a href="#">DO32</a>
SP73	TscR	SCKx Input Rise Time	—	—	—	ns	See Parameter <a href="#">DO31</a>
SP30	TdoF	SDOx Data Output Fall Time	—	—	—	ns	See Parameter <a href="#">DO32</a>
SP31	TdoR	SDOx Data Output Rise Time	—	—	—	ns	See Parameter <a href="#">DO31</a>
SP35	TscH2doV, TscL2doV	SDOx Data Output Valid After SCKx Edge	—	6	20	ns	
SP36	TdoV2scH, TdoV2scL	SDOx Data Output Setup to First SCKx Edge	30	—	—	ns	Using PPS pins
			20	—	—	ns	SPIx dedicated pins
SP40	TdiV2scH, TdiV2scL	Setup Time of SDIx Data Input to SCKx Edge	30	—	—	ns	Using PPS pins
			10	—	—	ns	SPIx dedicated pins
SP41	Tsch2diL, TscL2diL	Hold Time of SDIx Data Input to SCKx Edge	30	—	—	ns	Using PPS pins
			15	—	—	ns	SPIx dedicated pins
SP50	TssL2scH, TssL2scL	$\overline{\text{SSx}}$ ↓ to SCKx ↑ or SCKx ↓ Input	120	—	—	ns	
SP51	TssH2doZ	$\overline{\text{SSx}}$ ↑ to SDOx Output High-Impedance	8	—	50	ns	
SP52	Tsch2ssH, TscL2ssH	$\overline{\text{SSx}}$ ↑ After SCKx Edge	$1.5 T_{CY} + 40$	—	—	ns	
SP60	TssL2doV	SDOx Data Output Valid After $\overline{\text{SSx}}$ Edge	—	—	50	ns	

**Note 1:** These parameters are characterized but not tested in manufacturing.

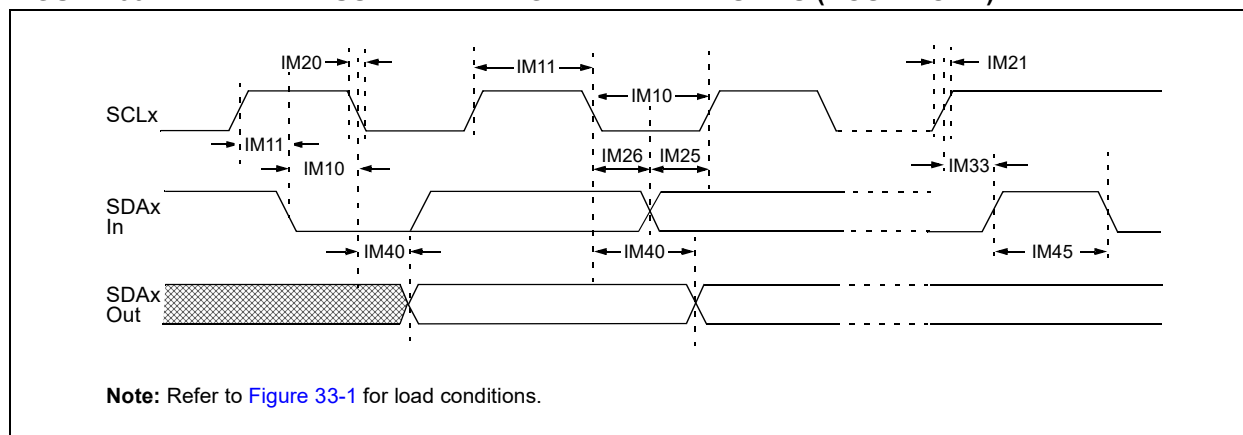
**2:** Data in the “Typ.” column are at 3.3V, +25°C unless otherwise stated.

# dsPIC33CK256MP508 FAMILY

**FIGURE 33-13: I2Cx BUS START/STOP BITS TIMING CHARACTERISTICS (HOST MODE)**



**FIGURE 33-14: I2Cx BUS DATA TIMING CHARACTERISTICS (HOST MODE)**



# dsPIC33CK256MP508 FAMILY

**TABLE 33-34: I2Cx BUS DATA TIMING REQUIREMENTS (HOST MODE)**

Operating Conditions: 3.0V to 3.6V (unless otherwise stated)							
Operating temperature -40°C ≤ TA ≤ +85°C for Industrial							
-40°C ≤ TA ≤ +125°C for Extended							
Param No.	Symbol	Characteristic <sup>(4)</sup>		Min. <sup>(1)</sup>	Max.	Units	Conditions
IM10	TLO:SCL	Clock Low Time	100 kHz mode	T <sub>CY</sub> (BRG + 1)	—	μs	
			400 kHz mode	T <sub>CY</sub> (BRG + 1)	—	μs	
			1 MHz mode <sup>(2)</sup>	T <sub>CY</sub> (BRG + 1)	—	μs	
IM11	THI:SCL	Clock High Time	100 kHz mode	T <sub>CY</sub> (BRG + 1)	—	μs	
			400 kHz mode	T <sub>CY</sub> (BRG + 1)	—	μs	
			1 MHz mode <sup>(2)</sup>	T <sub>CY</sub> (BRG + 1)	—	μs	
IM20	TF:SCL	SDAx and SCLx Fall Time	100 kHz mode	—	300	ns	Cb is specified to be from 10 to 400 pF
			400 kHz mode	20 x (V <sub>DD</sub> /5.5V)	300	ns	
			1 MHz mode <sup>(2)</sup>	20 x (V <sub>DD</sub> /5.5V)	120	ns	
IM21	TR:SCL	SDAx and SCLx Rise Time	100 kHz mode	—	1000	ns	Cb is specified to be from 10 to 400 pF
			400 kHz mode	20 + 0.1 Cb	300	ns	
			1 MHz mode <sup>(2)</sup>	—	120	ns	
IM25	TSU:DAT	Data Input Setup Time	100 kHz mode	250	—	ns	
			400 kHz mode	100	—	ns	
			1 MHz mode <sup>(2)</sup>	50	—	ns	
IM26	THD:DAT	Data Input Hold Time	100 kHz mode	0	—	μs	
			400 kHz mode	0	0.9	μs	
			1 MHz mode <sup>(2)</sup>	0	0.3	μs	
IM30	TSU:STA	Start Condition Setup Time	100 kHz mode	T <sub>CY</sub> (BRG + 1)	—	μs	Only relevant for Repeated Start condition
			400 kHz mode	T <sub>CY</sub> (BRG + 1)	—	μs	
			1 MHz mode <sup>(2)</sup>	T <sub>CY</sub> (BRG + 1)	—	μs	
IM31	THD:STA	Start Condition Hold Time	100 kHz mode	T <sub>CY</sub> (BRG + 1)	—	μs	After this period, the first clock pulse is generated
			400 kHz mode	T <sub>CY</sub> (BRG + 1)	—	μs	
			1 MHz mode <sup>(2)</sup>	T <sub>CY</sub> (BRG + 1)	—	μs	
IM33	TSU:STO	Stop Condition Setup Time	100 kHz mode	T <sub>CY</sub> (BRG + 1)	—	μs	
			400 kHz mode	T <sub>CY</sub> (BRG + 1)	—	μs	
			1 MHz mode <sup>(2)</sup>	T <sub>CY</sub> (BRG + 1)	—	μs	
IM34	THD:STO	Stop Condition Hold Time	100 kHz mode	T <sub>CY</sub> (BRG + 1)	—	μs	
			400 kHz mode	T <sub>CY</sub> (BRG + 1)	—	μs	
			1 MHz mode <sup>(2)</sup>	T <sub>CY</sub> (BRG + 1)	—	μs	
IM40	TAA:SCL	Output Valid from Clock	100 kHz mode	—	3450	ns	
			400 kHz mode	—	900	ns	
			1 MHz mode <sup>(2)</sup>	—	450	ns	
IM45	TBF:SDA	Bus Free Time	100 kHz mode	4.7	—	μs	Time the bus must be free before a new transmission can start
			400 kHz mode	1.3	—	μs	
			1 MHz mode <sup>(2)</sup>	0.5	—	μs	
IM50	CB	Bus Capacitive Loading		—	400	pF	
IM51	TPGD	Pulse Gobbler Delay		65	390	ns	Note 3

**Note 1:** BRG is the value of the I<sup>2</sup>C Baud Rate Generator.

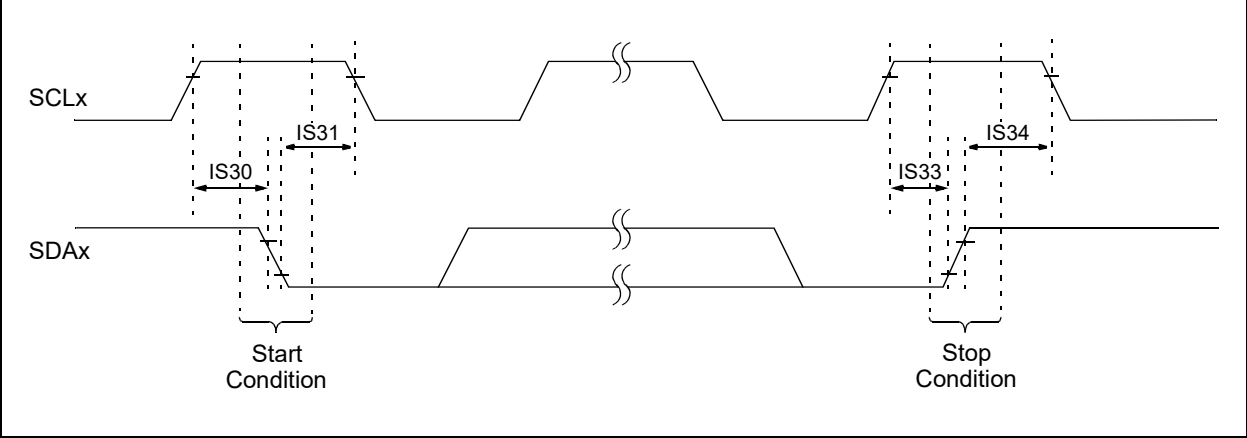
**2:** Maximum Pin Capacitance = 10 pF for all I2Cx pins (for 1 MHz mode only).

**3:** Typical value for this parameter is 130 ns.

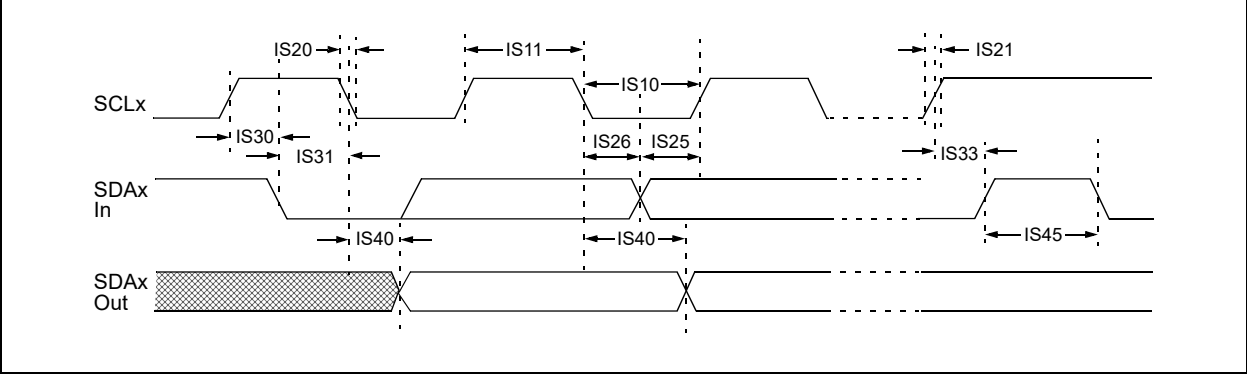
**4:** These parameters are characterized but not tested in manufacturing.

# dsPIC33CK256MP508 FAMILY

**FIGURE 33-15: I2Cx BUS START/STOP BITS TIMING CHARACTERISTICS (CLIENT MODE)**



**FIGURE 33-16: I2Cx BUS DATA TIMING CHARACTERISTICS (CLIENT MODE)**



# dsPIC33CK256MP508 FAMILY

**TABLE 33-35: I2Cx BUS DATA TIMING REQUIREMENTS (CLIENT MODE)**

Operating Conditions: 3.0V to 3.6V (unless otherwise stated)							
Operating temperature -40°C ≤ TA ≤ +85°C for Industrial							
-40°C ≤ TA ≤ +125°C for Extended							
Param No.	Symbol	Characteristic <sup>(3)</sup>		Min.	Max.	Units	Conditions
IS10	TLO:SCL	Clock Low Time	100 kHz mode	4.7	—	μs	
			400 kHz mode	1.3	—	μs	
			1 MHz mode <sup>(1)</sup>	0.5	—	μs	
IS11	THI:SCL	Clock High Time	100 kHz mode	4.0	—	μs	Device must operate at a minimum of 1.5 MHz
			400 kHz mode	0.6	—	μs	Device must operate at a minimum of 10 MHz
			1 MHz mode <sup>(1)</sup>	0.26	—	μs	
IS20	TF:SCL	SDAx and SCLx Fall Time	100 kHz mode	—	300	ns	CB is specified to be from 10 to 400 pF
			400 kHz mode	20 x (VDD/5.5V)	300	ns	
			1 MHz mode <sup>(1)</sup>	20 x (VDD/5.5V)	120	ns	
IS21	TR:SCL	SDAx and SCLx Rise Time	100 kHz mode	—	1000	ns	CB is specified to be from 10 to 400 pF
			400 kHz mode	20 + 0.1 CB	300	ns	
			1 MHz mode <sup>(1)</sup>	—	120	ns	
IS25	TSU:DAT	Data Input Setup Time	100 kHz mode	250	—	ns	
			400 kHz mode	100	—	ns	
			1 MHz mode <sup>(1)</sup>	50	—	ns	
IS26	THD:DAT	Data Input Hold Time	100 kHz mode	0	—	μs	
			400 kHz mode	0	0.9	μs	
			1 MHz mode <sup>(1)</sup>	0	0.3	μs	
IS30	TSU:STA	Start Condition Setup Time	100 kHz mode	4.7	—	μs	Only relevant for Repeated Start condition
			400 kHz mode	0.6	—	μs	
			1 MHz mode <sup>(1)</sup>	0.26	—	μs	
IS31	THD:STA	Start Condition Hold Time	100 kHz mode	4.0	—	μs	After this period, the first clock pulse is generated
			400 kHz mode	0.6	—	μs	
			1 MHz mode <sup>(1)</sup>	0.26	—	μs	
IS33	TSU:STO	Stop Condition Setup Time	100 kHz mode	4.0	—	μs	
			400 kHz mode	0.6	—	μs	
			1 MHz mode <sup>(1)</sup>	0.26	—	μs	
IS34	THD:STO	Stop Condition Hold Time	100 kHz mode	>0	—	μs	
			400 kHz mode	>0	—	μs	
			1 MHz mode <sup>(1)</sup>	>0	—	μs	
IS40	TAA:SCL	Output Valid from Clock	100 kHz mode	0	3450	ns	
			400 kHz mode	0	900	ns	
			1 MHz mode <sup>(1)</sup>	0	450	ns	
IS45	TBF:SDA	Bus Free Time	100 kHz mode	4.7	—	μs	Time the bus must be free before a new transmission can start
			400 kHz mode	1.3	—	μs	
			1 MHz mode <sup>(1)</sup>	0.5	—	μs	
IS50	CB	Bus Capacitive Loading		—	400	pF	
IS51	TPGD	Pulse Gobbler Delay		65	390	ns	<b>Note 2</b>

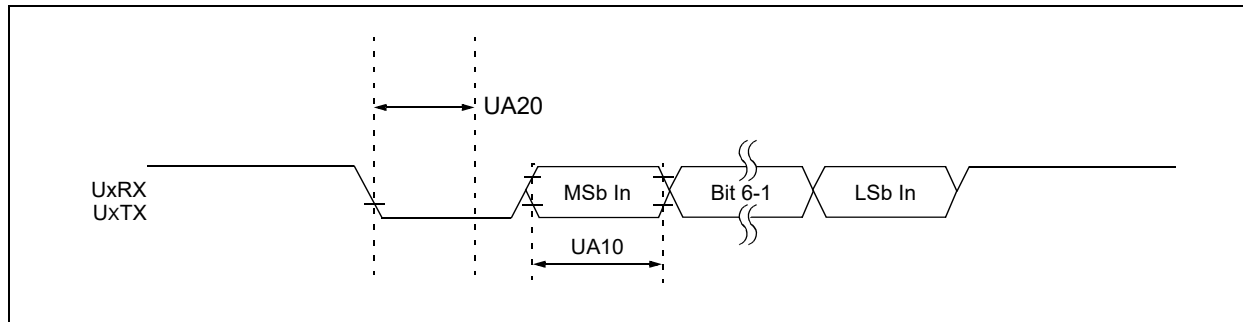
**Note 1:** Maximum Pin Capacitance = 10 pF for all I2Cx pins (for 1 MHz mode only).

**2:** Typical value for this parameter is 130 ns.

**3:** These parameters are characterized but not tested in manufacturing.

# dsPIC33CK256MP508 FAMILY

**FIGURE 33-17: UARTx MODULE I/O TIMING CHARACTERISTICS**



**TABLE 33-36: UARTx MODULE I/O TIMING REQUIREMENTS**

Operating Conditions: 3.0V to 3.6V (unless otherwise stated)							
Operating temperature $-40^{\circ}\text{C} \leq T_A \leq +125^{\circ}\text{C}$							
Param No.	Symbol	Characteristic <sup>(1)</sup>	Min.	Typ. <sup>(2)</sup>	Max.	Units	Conditions
UA10	TUABAUD	UARTx Baud Time	40	—	—	ns	
UA11	FBAUD	UARTx Baud Frequency	—	—	25	Mbps	
UA20	TCWF	Start Bit Pulse Width to Trigger UARTx Wake-up	50	—	—	ns	

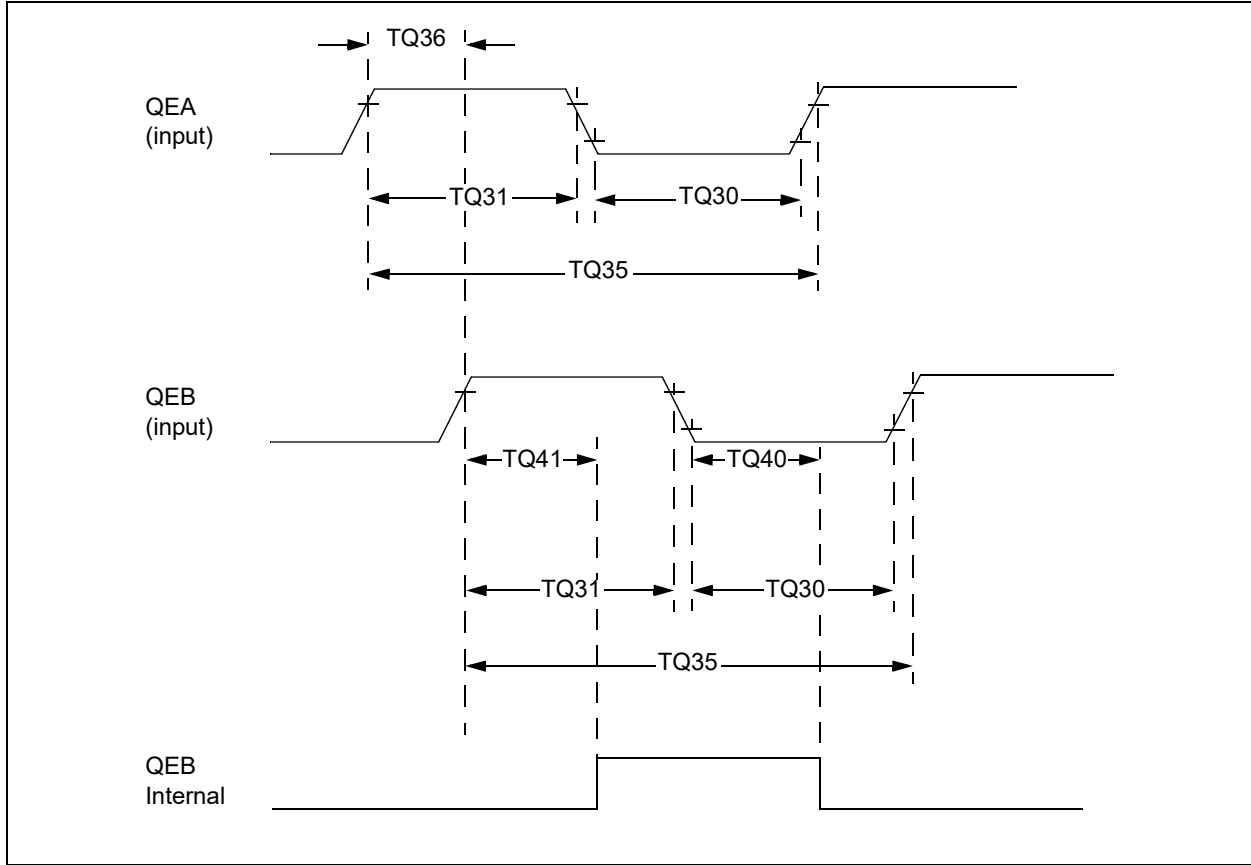
**Note 1:** These parameters are characterized but not tested in manufacturing.

**Note 2:** Data in the “Typ.” column are at 3.3V, +25°C unless otherwise stated. Parameters are for design guidance only and are not tested.



# dsPIC33CK256MP508 FAMILY

**FIGURE 33-18: QEA/QEB INPUT CHARACTERISTICS**



**TABLE 33-37: QUADRATURE DECODER TIMING REQUIREMENTS**

AC CHARACTERISTICS			Standard Operating Conditions: 3.0V to 3.6V (unless otherwise stated) Operating temperature $-40^{\circ}\text{C} \leq T_A \leq +85^{\circ}\text{C}$ for Industrial $-40^{\circ}\text{C} \leq T_A \leq +125^{\circ}\text{C}$ for Extended			
Param.	Symbol	Characteristic <sup>(1)</sup>	Typ. <sup>(2)</sup>	Max.	Units	Conditions
TQ30	TQUL	Quadrature Input Low Time	6 T <sub>cy</sub>	—	ns	
TQ31	TQUH	Quadrature Input High Time	6 T <sub>cy</sub>	—	ns	
TQ35	TQUIN	Quadrature Input Period	12 T <sub>cy</sub>	—	ns	
TQ36	TQUP	Quadrature Phase Period	3 T <sub>cy</sub>	—	ns	
TQ40	TQUFL	Filter Time to Recognize Low with Digital Filter	3 * N * T <sub>cy</sub>	—	ns	N = 1, 2, 4, 16, 32, 64, 128 and 256 (Note 3)
TQ41	TQUFH	Filter Time to Recognize High with Digital Filter	3 * N * T <sub>cy</sub>	—	ns	N = 1, 2, 4, 16, 32, 64, 128 and 256 (Note 3)

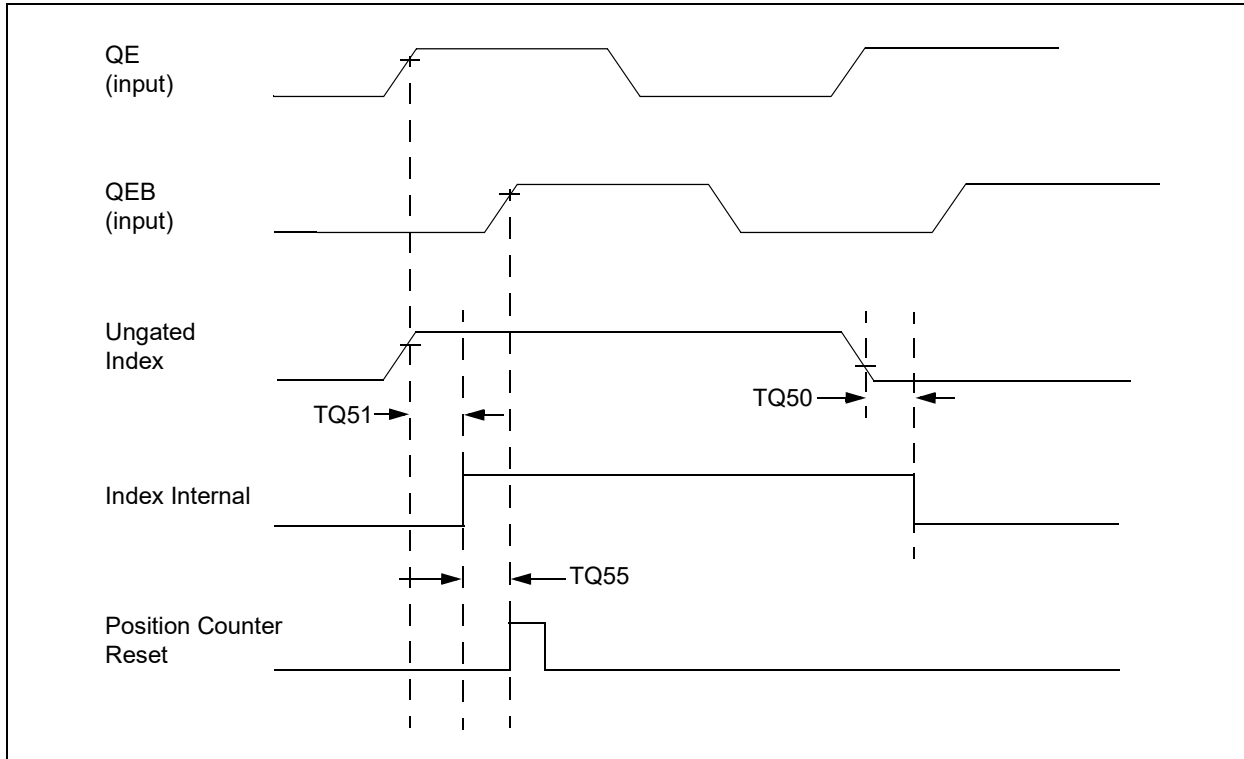
**Note 1:** These parameters are characterized but not tested in manufacturing.

**Note 2:** Data in “Typ” column is at 3.3V, +25°C unless otherwise stated. Parameters are for design guidance only and are not tested.

**Note 3:** N = Index Channel Digital Filter Clock Divide Select bits. Refer to **Section 15. “Quadrature Encoder Interface (QEI)”** (DS70000601) in the “dsPIC33/PIC24 Family Reference Manual”. Please see the Microchip website for the latest family reference manual sections.

# dsPIC33CK256MP508 FAMILY

**FIGURE 33-19: QEI MODULE INDEX PULSE TIMING CHARACTERISTICS**



**TABLE 33-38: QEI INDEX PULSE TIMING REQUIREMENTS**

AC CHARACTERISTICS			Standard Operating Conditions: 3.0V to 3.6V (unless otherwise stated) Operating temperature $-40^{\circ}\text{C} \leq T_A \leq +85^{\circ}\text{C}$ for Industrial $-40^{\circ}\text{C} \leq T_A \leq +125^{\circ}\text{C}$ for Extended			
Param.	Symbol	Characteristic <sup>(1)</sup>	Min.	Max.	Units	Conditions
TQ50	TqIL	Filter Time to Recognize Low with Digital Filter	$3 * N * T_{CY}$	—	ns	N = 1, 2, 4, 16, 32, 64, 128 and 256 ( <b>Note 2</b> )
TQ51	TqiH	Filter Time to Recognize High with Digital Filter	$3 * N * T_{CY}$	—	ns	N = 1, 2, 4, 16, 32, 64, 128 and 256 ( <b>Note 2</b> )
TQ55	Tqidxr	Index Pulse Recognized to Position Counter Reset (ungated index)	$3 T_{CY}$	—	ns	

**Note 1:** These parameters are characterized but not tested in manufacturing.

**Note 2:** Alignment of index pulses to QEA and QEB is shown for position counter Reset timing only. Shown for forward direction only (QEA leads QEB). Same timing applies for reverse direction (QEA lags QEB), but index pulse recognition occurs on the falling edge.

# dsPIC33CK256MP508 FAMILY

**TABLE 33-39: ADC MODULE SPECIFICATIONS**

Standard Operating Conditions: 3.0V to 3.6V <sup>(4)</sup> (unless otherwise stated)							
-40°C ≤ TA ≤ +85°C for Industrial							
-40°C ≤ TA ≤ +125°C for Extended							
Param No.	Symbol	Characteristics	Min.	Typical	Max.	Units	Conditions
<b>Analog Input</b>							
AD12	VINH-VINL	Full-Scale Input Span	AVSS	—	AVDD	V	
AD14	VIN	Absolute Input Voltage	AVSS – 0.3	—	AVDD + 0.3	V	
AD60	CHOLD	Capacitance	—	5	—	pF	Dedicated cores ( <b>Note 1</b> )
AD61	CHOLD	Capacitance	—	18	—	pF	Shared core ( <b>Note 1</b> )
AD62	RIc	Input resistance	—	500	1000	Ω	<b>Note 1</b>
AD66	VBG	Internal Voltage Reference Source	1.14	1.2	1.26	V	
<b>Clock Requirements</b>							
AD67	FSRC	ADC Module Input Frequency	—	—	500	MHz	Clock frequency selected by the CLKSELx bits
	FCORESRC	ADC Control Clock Frequency	—	—	250	MHz	Clock frequency after the first divider controlled by the CLKDIVx bits
	FADCORE	ADC SAR Core Clock Frequency	—	—	70	MHz	SAR core frequency after the second divider controlled by the ADCSx or SHRADCSx bits
<b>ADC Accuracy</b>							
AD20	Nr	Resolution	12 data bits			bits	
AD21a	INL_1D	Dedicated Core Integral Nonlinearity (1 Active Core)	-3.5	-1.5/+1.5	+3.5	LSb	3.5 Msps <sup>(5)</sup> , TADC = 4 nS (250 MHz), TCORESRC = 8 nS (125 MHz), TADCORE = 16 nS (62.5 MHz), Sampling Time = 4 TADCORE, VDD = 3.3V, AVDD = 3.3V
AD22a	DNL_1D	Dedicated Core Differential Nonlinearity (1 Active Core)	-1	1.5/+1.5	+3.5	LSb	
AD23a	GERR_1D	Dedicated Core Gain Error (1 Active Core)	—	+4	—	LSb	
AD24a	OERR_1D	Dedicated Core Offset Error (1 Active Core)	—	-4	—	LSb	

- Note 1:** These parameters are not characterized or tested in manufacturing.
- 2:** These parameters are characterized but not tested in manufacturing.
- 3:** Characterized with a 1 kHz sine wave.
- 4:** The ADC module is functional at VBORMIN < VDD < VDDMIN, but with degraded performance. Unless otherwise stated, module functionality is ensured, but not characterized.
- 5:** For the dedicated core, the throughput includes 4 TADCORE sampling time and 13 TADCORE conversion time.
- 6:** For the shared core, the throughput includes 10 TADCORE sampling time and 13 TADCORE conversion time.

# dsPIC33CK256MP508 FAMILY

**TABLE 33-39: ADC MODULE SPECIFICATIONS (CONTINUED)**

Standard Operating Conditions: 3.0V to 3.6V <sup>(4)</sup> (unless otherwise stated)							
-40°C ≤ TA ≤ +85°C for Industrial							
-40°C ≤ TA ≤ +125°C for Extended							
Param No.	Symbol	Characteristics	Min.	Typical	Max.	Units	Conditions
AD21b	INL_1S	Shared Core Integral Nonlinearity (1 Active Core)	-3.5	-1.5/+1.5	+3.5	LSb	2.7 Msps <sup>(6)</sup> , TADC = 4 nS (250 MHz), TCORESRC = 8 nS (125 MHz), TADCORE = 16 nS (62.5 MHz), Sampling Time = 10 TADCORE, VDD = 3.3V, AVDD = 3.3V
AD22b	DNL_1S	Shared Core Differential Nonlinearity (1 Active Core)	-1	1.5	+3.5	LSb	
AD23b	GERR_1S	Shared Core Gain Error (1 Active Core)	—	+4	—	LSb	
AD24b	OERR_1S	Shared Core Offset Error (1 Active Core)	—	-4	—	LSb	
AD21c	INL_3D	Dedicated Core Integral Nonlinearity (3 Active Cores)	—	-5/+5	—	LSb	3.5 Msps <sup>(5)</sup> , TADC = 4 nS (250 MHz), TCORESRC = 8 nS (125 MHz), TADCORE = 16 nS (62.5 MHz), Sampling Time = 4 TADCORE, VDD = 3.3V, AVDD = 3.3V, all core conversions are started simultaneously
AD22c	DNL_3D	Dedicated Core Differential Nonlinearity (3 Active Cores)	—	-1/+2	—	LSb	
AD23c	GERR_3D	Dedicated Core Gain Error (3 Active Cores)	—	+5	—	LSb	
AD24c	OERR_3D	Dedicated Core Offset Error (3 Active Cores)	—	-5	—	LSb	
AD21d	INL_3S	Shared Core Integral Nonlinearity (3 Active Cores)	—	-5/+5	—	LSb	2.7 Msps <sup>(6)</sup> , TADC = 4 nS (250 MHz), TCORESRC = 8 nS (125 MHz), TADCORE = 16 nS (62.5 MHz), Sampling Time = 10 TADCORE, VDD = 3.3V, AVDD = 3.3V, all core conversions are started simultaneously
AD22d	DNL_3S	Shared Core Differential Nonlinearity (3 Active Cores)	—	-1/+2	—	LSb	
AD23d	GERR_3S	Shared Core Gain Error (3 Active Cores)	—	+5	—	LSb	
AD24d	OERR_3S	Shared Core Offset Error (3 Active Cores)	—	-5	—	LSb	
AD25c	—	Monotonicity	—	—	—	—	Guaranteed

- Note 1:** These parameters are not characterized or tested in manufacturing.
- 2:** These parameters are characterized but not tested in manufacturing.
- 3:** Characterized with a 1 kHz sine wave.
- 4:** The ADC module is functional at VBORMIN < VDD < VDDMIN, but with degraded performance. Unless otherwise stated, module functionality is ensured, but not characterized.
- 5:** For the dedicated core, the throughput includes 4 TADCORE sampling time and 13 TADCORE conversion time.
- 6:** For the shared core, the throughput includes 10 TADCORE sampling time and 13 TADCORE conversion time.

# dsPIC33CK256MP508 FAMILY

**TABLE 33-39: ADC MODULE SPECIFICATIONS (CONTINUED)**

Standard Operating Conditions: 3.0V to 3.6V <sup>(4)</sup> (unless otherwise stated)							
-40°C ≤ TA ≤ +85°C for Industrial							
-40°C ≤ TA ≤ +125°C for Extended							
Param No.	Symbol	Characteristics	Min.	Typical	Max.	Units	Conditions
<b>Dynamic Performance</b>							
AD31b	SINAD	Signal-to-Noise and Distortion	56	—	70	dB	Notes 2,3
AD34b	ENOB	Effective Number of Bits	9.8	10.2	11.4	bits	Notes 2,3
AD50	TAD	ADC Clock Period	14.3	—	—	ns	
AD51	FTP	Throughput Rate	—	—	3.5	Msp/s	Dedicated Cores 0 and 1 (Note 5)
			—	—	2.7	Msp/s	Shared core (Note 6)
<b>Die Temperature Diode Specification</b>							
TD01	TCOEFF		—	1.5	—	mV/C	Note 1

- Note 1:** These parameters are not characterized or tested in manufacturing.
- 2:** These parameters are characterized but not tested in manufacturing.
- 3:** Characterized with a 1 kHz sine wave.
- 4:** The ADC module is functional at VBORMIN < VDD < VDDMIN, but with degraded performance. Unless otherwise stated, module functionality is ensured, but not characterized.
- 5:** For the dedicated core, the throughput includes 4 TADCORE sampling time and 13 TADCORE conversion time.
- 6:** For the shared core, the throughput includes 10 TADCORE sampling time and 13 TADCORE conversion time.

**TABLE 33-40: HIGH-SPEED ANALOG COMPARATOR MODULE SPECIFICATIONS**

Operating Conditions: 3.0V to 3.6V (unless otherwise stated) <sup>(2)</sup>							
Operating temperature -40°C ≤ TA ≤ +85°C for Industrial							
-40°C ≤ TA ≤ +125°C for Extended							
Param No.	Symbol	Characteristic	Min.	Typ. <sup>(1)</sup>	Max.	Units	Comments
CM09	FIN	Input Frequency	400	500	550	MHz	
CM10	VIOFF	Input Offset Voltage	-20	—	+20	mV	
CM11	VICM	Input Common-Mode Voltage Range	AVSS	—	AVDD	V	Note 1
CM13	CMRR	Common-Mode Rejection Ratio	65	—	—	dB	Note 1
CM14	TRESP	Large Signal Response	—	15	—	ns	V+ input step of 100 mV while V- input is held at AVDD/2
CM15	VHYST	Input Hysteresis	15	—	45	mV	Dependent on HYSSEL[1:0] (Note 1)

- Note 1:** These parameters are for design guidance only and are not tested in manufacturing.
- 2:** The comparator module is functional at VBORMIN < VDD < VDDMIN, but with degraded performance. Unless otherwise stated, module functionality is tested, but not characterized.

# dsPIC33CK256MP508 FAMILY

**TABLE 33-41: DACx MODULE SPECIFICATIONS**

Operating Conditions: 3.0V to 3.6V (unless otherwise stated)							
Operating temperature -40°C ≤ TA ≤ +85°C for Industrial -40°C ≤ TA ≤ +125°C for Extended							
Param No.	Symbol	Characteristic	Min.	Typ. <sup>(1)</sup>	Max.	Units	Comments
DA02	CVRES	Resolution	12			bits	
DA03	INL	Integral Nonlinearity Error	-38	—	0	LSB	
DA04	DNL	Differential Nonlinearity Error	-5	—	5	LSB	
DA05	EOFF	Offset Error	-3.5	—	21.5	LSB	Internal node at comparator input
DA06	EG	Gain Error	0	—	41	LSB	Internal node at comparator input
DA07	TSET	Settling Time	600	750	2000	ns	Output within 1% of desired output voltage with a 5%-95% or 95%-5% step ( <b>Note 1</b> )
DA08	VOUT	Voltage Output Range	0.165	—	3.135	V	VDD = 3.3V
DA09	TTR	Transition Time	340	—	—	ns	<b>Note 1</b>
DA10	TSS	Steady-State Time	550	—	—	ns	<b>Note 1</b>

**Note 1:** Parameters are for design guidance only and are not tested in manufacturing.

**TABLE 33-42: DACx OUTPUT (DACOUT1 PIN) SPECIFICATIONS**

Operating Conditions: 3.0V to 3.6V (unless otherwise stated) <sup>(1,2,3)</sup>							
Operating temperature -40°C ≤ TA ≤ +85°C for Industrial -40°C ≤ TA ≤ +125°C for Extended							
Param No.	Symbol	Characteristic	Min.	Typ.	Max.	Units	Comments
DA11	RLOAD	Resistive Output Load Impedance	10K	—	—	Ohm	
DA11a	CLOAD	Output Load Capacitance	—	—	30	pF	Including output pin capacitance
DA12	IOUT	Output Current Drive Strength	—	3	—	mA	Sink and source

**Note 1:** Parameters are for design guidance only and are not tested in manufacturing.

**2:** The DACx module is functional at VBORMIN < VDD < VDDMIN, but with degraded performance. Unless otherwise stated, module functionality is tested, but not characterized.

**3:** Using other pin functions may degrade DAC performance.

# dsPIC33CK256MP508 FAMILY

**TABLE 33-43: CONSTANT-CURRENT SOURCE SPECIFICATIONS**

Operating Conditions: 3.0V to 3.6V (unless otherwise stated) <sup>(1)</sup>							
Operating temperature -40°C ≤ TA ≤ +85°C for Industrial -40°C ≤ TA ≤ +125°C for Extended							
Param No.	Symbol	Characteristic	Min.	Typ.	Max.	Units	Conditions
CC03	I10SRC	10 μA Source Current	8.8	—	11.2	μA	ISRCx pin
CC04	I50SRC	50 μA Source Current	44	—	56	μA	IBIASx pin
CC05	I50SNK	50 μA Sink Current	-44	—	-56	μA	IBIASx pin

**Note 1:** The constant-current source module is functional at VBORMIN < VDD < VDDMIN, but with degraded performance. Unless otherwise stated, module functionality is tested, but not characterized.

**TABLE 33-44: OPERATIONAL AMPLIFIER SPECIFICATIONS**

Operating Conditions: 3.0V to 3.6V (unless otherwise stated)							
Operating temperature -40°C ≤ TA ≤ +85°C for Industrial -40°C ≤ TA ≤ +125°C for Extended							
Param No.	Sym	Characteristic	Min	Typ <sup>(1)</sup>	Max	Units	Comments
OA01	GBWP	Gain Bandwidth Product	—	20	—	MHz	
OA02	SR	Slew Rate	—	40	—	V/μs	
OA03	VIOFF	Input Offset Voltage	-3 <sup>(3)</sup>	-1/+1	+3 <sup>(3)</sup>	mV	Unity gain configuration
			-8	-3/+3	+8	mV	Open-loop configuration
OA04	VIBC	Input Bias Current	—	—	—	mV	<b>Note 2</b>
OA05	VICM	Common-Mode Input Voltage Range	AVSS	—	AVDD	V	NCHDISx = 0
			AVSS	—	AVDD - 1.4	V	NCHDISx = 1
OA07	CMRR	Common-Mode Rejection Ratio	—	68	—	dB	
OA08	PSRR	Power Supply Rejection Ratio	—	74	—	dB	
OA09	VOR	Output Voltage Range	AVSS	—	AVDD	mV	0.5V input overdrive, no output loading ( <b>Note 1</b> )
OA11	CLOAD	Output Load Capacitance	—	—	30	pF	Including output pin capacitance ( <b>Note 1</b> )
OA12	IOUT	Output Current Drive Strength	—	3	—	mA	Sink and source
OA13	PMARGIN	Phase Margin	44	—	—	degree	Unity gain ( <b>Note 1</b> )
OA14	GMARGIN	Gain Margin	7	—	—	dB	Unity gain ( <b>Note 1</b> )
OA15	OLG	Open-Loop Gain	68	75	—	dB	<b>Note 1</b>

**Note 1:** These parameters are for design guidance only and are not tested in manufacturing.

**2:** The op amps use CMOS input circuitry with negligible input bias current. The maximum “effective bias current” is the I/O pin leakage specified by electrical Parameter [DI50](#).

**3:** Parameters are characterized but not tested in manufacturing.

# dsPIC33CK256MP508 FAMILY

---

NOTES:



# dsPIC33CK256MP508 FAMILY

## 34.0 HIGH-TEMPERATURE ELECTRICAL CHARACTERISTICS

This section provides an overview of the dsPIC33CK256MP508 family devices operating in an ambient temperature range of -40°C to +150°C.

The specifications between -40°C to +150°C are identical to those shown in [Section 33.0 “Electrical Characteristics”](#) for operation between -40°C to +125°C, with the exception of the parameters listed in this section.

Parameters in this section begin with an H, which denotes High temperature. For example, Parameter [DC20](#) in [Section 33.0 “Electrical Characteristics”](#) is the Industrial and Extended temperature equivalent of [HDC20](#).

Absolute maximum ratings for the dsPIC33CK256MP508 family high-temperature devices are listed below. Exposure to these maximum rating conditions for extended periods can affect device reliability. Functional operation of the device, at these or any other conditions above the parameters indicated in the operation listings of this specification, is not implied.

### Absolute Maximum Ratings<sup>(1)</sup>

Ambient temperature under bias .....	-40°C to +150°C
Storage temperature .....	-65°C to +150°C
Voltage on VDD with respect to Vss .....	-0.3V to +4.0V
Voltage on any pin that is not 5V tolerant with respect to Vss <sup>(3)</sup> .....	-0.3V to (VDD + 0.3V)
Voltage on any 5V tolerant pin with respect to Vss when VDD ≥ 3.0V <sup>(3)</sup> .....	-0.3V to +5.5V
Voltage on any 5V tolerant pin with respect to Vss when VDD < 3.0V <sup>(3)</sup> .....	-0.3V to +3.6V
Maximum current out of Vss pin .....	300 mA
Maximum current into VDD pin <sup>(2)</sup> .....	300 mA
Maximum current sunk/sourced by any 4x I/O pin .....	15 mA
Maximum current sunk/sourced by any 8x I/O pin .....	25 mA
Maximum current sunk by a group of I/Os between two Vss pins <sup>(4)</sup> .....	75 mA
Maximum current sourced by a group of I/Os between two VDD pins <sup>(4)</sup> .....	75 mA
Maximum current sunk by all I/Os <sup>(2,5)</sup> .....	200 mA
Maximum current sourced by all I/Os <sup>(2,5)</sup> .....	200 mA

**Note 1:** Stresses above those listed under “Absolute Maximum Ratings” may cause permanent damage to the device. This is a stress rating only and functional operation of the device at those, or any other conditions above those indicated in the operation listings of this specification, is not implied. Exposure to maximum rating conditions for extended periods may affect device reliability.

**2:** Maximum allowable current is a function of device maximum power dissipation (see [Table 34-2](#)).

**3:** See the “[Pin Diagrams](#)” section for the 5V tolerant pins.

**4:** Not applicable to AVDD and AVss pins.

**5:** For 28-pin packages, the maximum current sunk/sourced by all I/Os is limited by 150 mA.

# dsPIC33CK256MP508 FAMILY

## 34.1 DC Characteristics

**TABLE 34-1: OPERATING MIPS vs. VOLTAGE**

VDD Range	Temperature Range	Maximum CPU Clock Frequency
3.0V to 3.6V	-40°C to +150°C	70

**TABLE 34-2: THERMAL OPERATING CONDITIONS**

Rating	Symbol	Min.	Max.	Unit
High-Temperature Devices				
Operating Junction Temperature Range	TJ	-40	+165	°C
Operating Ambient Temperature Range	TA	-40	+150	°C
Power Dissipation: Internal Chip Power Dissipation: PINT = VDD x (IDD – Σ IOH) I/O Pin Power Dissipation: I/O = Σ ({VDD – VOH} x IOH) + Σ (VOL x IOL)	PD	PINT + PI/O		W
Maximum Allowed Power Dissipation	PDMAX	(TJ – TA)/θJA		W

**TABLE 34-3: THERMAL PACKAGING CHARACTERISTICS<sup>(1)</sup>**

Characteristic	Symbol	Typ.	Unit
Package Thermal Resistance, 80-Pin TQFP 12x12x1 mm	θJA	50.67	°C/W
Package Thermal Resistance, 64-Pin TQFP 10x10x1.0 mm	θJA	45.7	°C/W
Package Thermal Resistance, 64-Pin QFN 9x9 mm	θJA	18.7	°C/W
Package Thermal Resistance, 48-Pin TQFP 7x7 mm	θJA	62.76	°C/W
Package Thermal Resistance, 48-Pin UQFN 6x6 mm	θJA	27.6	°C/W
Package Thermal Resistance, 36-Pin UQFN 5x5 mm	θJA	29.2	°C/W
Package Thermal Resistance, 28-Pin UQFN 6x6 mm	θJA	22.41	°C/W
Package Thermal Resistance, 28-Pin SSOP 5.30 mm	θJA	52.84	°C/W

**Note 1:** Junction to ambient thermal resistance, Theta-JA (θJA) numbers are achieved by package simulations.

# dsPIC33CK256MP508 FAMILY

**TABLE 34-4: OPERATING VOLTAGE SPECIFICATIONS**

Operating Conditions: 3.0V to 3.6V (unless otherwise stated) <sup>(1)</sup> Operating temperature $-40^{\circ}\text{C} \leq T_A \leq +150^{\circ}\text{C}$							
Param No.	Symbol	Characteristic	Min.	Typ.	Max.	Units	Conditions
<b>Operating Voltage</b>							
DC10	VDD	<b>Supply Voltage</b>	3.0	—	3.6	V	
DC11	AVDD	<b>Supply Voltage</b>	Greater of: VDD – 0.3 or 3.0	—	Lesser of: VDD + 0.3 or 3.6	V	The difference between AVDD supply and VDD supply must not exceed $\pm 300$ mV at all times, including during device power-up
DC16	VPOR	<b>VDD Start Voltage</b> to Ensure Internal Power-on Reset Signal	—	—	VSS	V	
DC17	SVDD	<b>VDD Rise Rate</b> to Ensure Internal Power-on Reset Signal	0.03	—	—	V/ms	0V-3V in 100 ms
BO10	VBOR	<b>BOR Event on VDD Transition</b> High-to-Low <sup>(2)</sup>	2.68	2.84	2.99	V	

**Note 1:** Device is functional at  $V_{BORMIN} < V_{DD} < V_{DDMIN}$ . Analog modules (ADC and comparators) may have degraded performance.

**2:** Parameters are characterized but not tested.

# dsPIC33CK256MP508 FAMILY

**TABLE 34-5: OPERATING CURRENT (I<sub>DD</sub>)<sup>(2)</sup>**

Operating Conditions: 3.0V to 3.6V (unless otherwise stated)						
Operating temperature $-40^{\circ}\text{C} \leq T_A \leq +150^{\circ}\text{C}$						
Parameter No.	Typ. <sup>(1)</sup>	Max.	Units	Conditions		
HDC20	13.6	33.5	mA	+150°C	3.3V	10 MIPS (N1 = 1, N2 = 5, N3 = 2, M = 50, F <sub>VCO</sub> = 400 MHz, F <sub>PLLO</sub> = 40 MHz)
HDC21	16.2	36.0	mA	+150°C	3.3V	20 MIPS (N1 = 1, N2 = 5, N3 = 1, M = 50, F <sub>VCO</sub> = 400 MHz, F <sub>PLLO</sub> = 80 MHz)
HDC22	20.4	40.0	mA	+150°C	3.3V	40 MIPS (N1 = 1, N2 = 3, N3 = 1, M = 60, F <sub>VCO</sub> = 480 MHz, F <sub>PLLO</sub> = 160 MHz)
HDC23	27.8	47.75	mA	+150°C	3.3V	70 MIPS (N1 = 1, N2 = 2, N3 = 1, M = 70, F <sub>VCO</sub> = 560 MHz, F <sub>PLLO</sub> = 280 MHz)

**Note 1:** Data in the “Typ.” column are for design guidance only and are not tested.

**2:** Base Run current (I<sub>DD</sub>) is measured as follows:

- Oscillator is switched to EC+PLL mode in software
- OSC1 pin is driven with external 8 MHz square wave with levels from 0.3V to V<sub>DD</sub> – 0.3V
- OSC2 is configured as an I/O in the Configuration Words (OSCIOFNC (FOSC[2]) = 0)
- FSCM is disabled (FCKSM[1:0] (FOSC[7:6]) = 01)
- Watchdog Timer is disabled (FWDT[15] = 0 and WDTCONL[15] = 0)
- All I/O pins (except OSC1) are configured as outputs and driving low
- No peripheral modules are operating or being clocked (defined PMDx bits are all ‘1’s)
- JTAG is disabled (JTAGEN (FICD[5]) = 0)
- NOP instructions are executed in `while(1)` loop

# dsPIC33CK256MP508 FAMILY

**TABLE 34-6: IDLE CURRENT (I<sub>IDLE</sub>)<sup>(2)</sup>**

Operating Conditions: 3.0V to 3.6V (unless otherwise stated) Operating temperature $-40^{\circ}\text{C} \leq T_A \leq +150^{\circ}\text{C}$						
Parameter No.	Typ. <sup>(1)</sup>	Max.	Units	Conditions		
HDC40	11.6	33.25	mA	+150°C	3.3V	10 MIPS (N1 = 1, N2 = 5, N3 = 2, M = 50, Fvco = 400 MHz, FPLLO = 40 MHz)
HDC41	12.7	33.75	mA	+150°C	3.3V	20 MIPS (N1 = 1, N2 = 5, N3 = 1, M = 50, Fvco = 400 MHz, FPLLO = 80 MHz)
HDC42	14.9	36.3	mA	+150°C	3.3V	40 MIPS (N1 = 1, N2 = 3, N3 = 1, M = 60, Fvco = 480 MHz, FPLLO = 160 MHz)
HDC43	18.0	39.75	mA	+150°C	3.3V	70 MIPS (N1 = 1, N2 = 2, N3 = 1, M = 70, Fvco = 560 MHz, FPLLO = 280 MHz)

**Note 1:** Data in the “Typ.” column are for design guidance only and are not tested.

**2:** Base Idle current (I<sub>IDLE</sub>) is measured as follows:

- Oscillator is switched to EC+PLL mode in software
- OSC1 pin is driven with external 8 MHz square wave with levels from 0.3V to V<sub>DD</sub> – 0.3V
- OSC2 is configured as an I/O in the Configuration Words (OSCIOFNC (FOSC[2]) = 0)
- FSCM is disabled (FCKSM[1:0] (FOSC[7:6]) = 01)
- Watchdog Timer is disabled (FWDT[15] = 0 and WDTCONL[15] = 0)
- All I/O pins (except OSC1) are configured as outputs and driving low
- No peripheral modules are operating or being clocked (defined PMDx bits are all ‘1’s)
- JTAG is disabled (JTAGEN (FICD[5]) = 0)
- Flash in standby with NVMSIDL (NVMCON[12]) = 1

# dsPIC33CK256MP508 FAMILY

**TABLE 34-7: POWER-DOWN CURRENT (IPD)<sup>(2)</sup>**

Operating Conditions: 3.0V to 3.6V (unless otherwise stated) Operating temperature $-40^{\circ}\text{C} \leq T_A \leq +150^{\circ}\text{C}$						
Parameter No.	Characteristic	Typ. <sup>(1)</sup>	Max.	Units	Conditions	
HDC60	Base Power-Down Current	8.9	29.2	mA	+150°C	3.3V

**Note 1:** Data in the “Typ.” column are for design guidance only and are not tested.

**2:** Base Sleep current (IPD) is measured as follows:

- OSC1 pin is driven with external 8 MHz square wave with levels from 0.3V to  $V_{DD} - 0.3V$
- OSC2 is configured as an I/O in the Configuration Words (OSCIOFNC (FOSC[2]) = 0)
- FSCM is disabled (FCKSM[1:0] (FOSC[7:6]) = 01)
- Watchdog Timer is disabled (FWDT[15] = 0 and WDTCONL[15] = 0)
- All I/O pins (except OSC1) are configured as outputs and driving low
- No peripheral modules are operating or being clocked (defined PMDx bits are all ‘1’s)
- JTAG is disabled (JTAGEN (FICD[5]) = 0)
- The regulators are in Standby mode (VREGS (RCON[8]) = 0)
- The regulators are in Low-Power mode (LPWREN (VREGCON[15]) = 1)

**TABLE 34-8: DOZE CURRENT (IDOZE)**

Operating Conditions: 3.0V to 3.6V (unless otherwise stated) Operating temperature $-40^{\circ}\text{C} \leq T_A \leq +150^{\circ}\text{C}$							
Parameter No.	Typ. <sup>(1)</sup>	Max.	Doze Ratio	Units	Conditions		
HDC70	23.6	43	1:2	mA	+150°C	3.3V	70 MIPS (N = 1, N2 = 2, N3 = 1, M = 70, FVCO = 560 MHz, FPLLO = 280 MHz)
	18.5	38.7	1:128	mA			

**Note 1:** Data in the “Typ.” column are for design guidance only and are not tested.

**TABLE 34-9: WATCHDOG TIMER DELTA CURRENT ( $\Delta I_{WDT}$ )<sup>(1)</sup>**

Operating Conditions: 3.0V to 3.6V (unless otherwise stated) Operating temperature $-40^{\circ}\text{C} \leq T_A \leq +150^{\circ}\text{C}$						
Parameter No.	Typ.	Max.	Units	Conditions		
HDC61	24	120	$\mu\text{A}$	+150°C	3.3V	

**Note 1:** The  $\Delta I_{WDT}$  current is the additional current consumed when the module is enabled. This current should be added to the base IPD current. All parameters are characterized but not tested during manufacturing.

# dsPIC33CK256MP508 FAMILY

**TABLE 34-10: PWM DELTA CURRENT<sup>(1)</sup>**

Operating Conditions: 3.0V to 3.6V (unless otherwise stated)						
Operating temperature $-40^{\circ}\text{C} \leq T_A \leq +150^{\circ}\text{C}$						
Parameter No.	Typ.	Max.	Units	Conditions		
HDC100	5.48	7.0	mA	+150°C	3.3V	PWM Output Frequency = 500 kHz, PWM Input (AFPLLO = 500 MHz) (AVCO = 1000 MHz, PLLFBD = 125, APLLDIV1 = 2)
HDC101	4.44	5.7	mA	+150°C	3.3V	PWM Output Frequency = 500 kHz, PWM Input (AFPLLO = 400 MHz), (AVCO = 400 MHz, PLLFBD = 50, APLLDIV1 = 1)
HDC102	2.31	3.7	mA	+150°C	3.3V	PWM Output Frequency = 500 kHz, PWM Input (AFPLLO = 200 MHz), (AVCO = 400 MHz, PLLFBD = 50, APLLDIV1 = 2)
HDC103	1.22	2.3	mA	+150°C	3.3V	PWM Output Frequency = 500 kHz, PWM Input (AFPLLO = 100 MHz), (AVCO = 400 MHz, PLLFBD = 50, APLLDIV1 = 4)

**Note 1:** APLL current is not included. The APLL current will be the same if more than one PWM is running. Listed delta currents are for only one PWM instance when HREN = 0 (PGxCONL[7]). All parameters are characterized but not tested during manufacturing.

**TABLE 34-11: APLL DELTA CURRENT**

Operating Conditions: 3.0V to 3.6V (unless otherwise stated)						
Operating temperature $-40^{\circ}\text{C} \leq T_A \leq +150^{\circ}\text{C}$						
Parameter No.	Typ.	Max.	Units	Conditions <sup>(1)</sup>		
HDC110	7.04	9.3	mA	+150°C	3.3V	AFPLLO = 500 MHz (AVCO = 1000 MHz, PLLFBD = 125, APLLDIV1 = 2)
HDC111	3.78	5.8	mA	+150°C	3.3V	AFPLLO = 400 MHz (AVCO = 400 MHz, PLLFBD = 50, APLLDIV1 = 1)
HDC112	2.49	4.5	mA	+150°C	3.3V	AFPLLO = 200 MHz (AVCO = 400 MHz, PLLFBD = 50, APLLDIV1 = 2)
HDC113	1.83	3.6	mA	+150°C	3.3V	AFPLLO = 100 MHz (AVCO = 400 MHz, PLLFBD = 50, APLLDIV1 = 4)

**Note 1:** The APLL current will be the same if more than one PWM or DAC is run to the APLL clock. All parameters are characterized but not tested during manufacturing.

# dsPIC33CK256MP508 FAMILY

**TABLE 34-12: ADC DELTA CURRENT<sup>(1)</sup>**

Operating Conditions: 3.0V to 3.6V (unless otherwise stated)						
Operating temperature $-40^{\circ}\text{C} \leq T_A \leq +150^{\circ}\text{C}$						
Parameter No.	Typ.	Max.	Units	Conditions		
HDC120	3.76	6.8	mA	+150°C	3.3V	TAD = 14.3 ns (3.5 Msps conversion rate)

**Note 1:** Shared core continuous conversion. TAD = 14.3 nS (3.5 Msps conversion rate). Listed delta currents are for only one ADC core. All parameters are characterized but not tested during manufacturing.

**TABLE 34-13: COMPARATOR + DAC DELTA CURRENT**

Operating Conditions: 3.0V to 3.6V (unless otherwise stated)						
Operating temperature $-40^{\circ}\text{C} \leq T_A \leq +150^{\circ}\text{C}$						
Parameter No.	Typ.	Max.	Units	Conditions		
HDC130	1.25	1.65	mA	+150°C	3.3V	AFPLLO @ 500 MHz <sup>(1)</sup>

**Note 1:** APLL current is not included. Listed delta currents are for only one comparator + DAC instance. All parameters are characterized but not tested during manufacturing.

**TABLE 34-14: OP AMP DELTA CURRENT<sup>(1)</sup>**

Operating Conditions: 3.0V to 3.6V (unless otherwise stated)						
Operating temperature $-40^{\circ}\text{C} \leq T_A \leq +150^{\circ}\text{C}$						
Parameter No.	Typ.	Max.	Units	Conditions		
HDC140	0.58	2.3	mA	+150°C	3.3V	

**Note 1:** Listed delta currents are for only one op amp instance. All parameters are characterized but not tested during manufacturing.



# dsPIC33CK256MP508 FAMILY

**TABLE 34-15: I/O PIN INPUT SPECIFICATIONS**

Operating Conditions: 3.0V to 3.6V (unless otherwise stated) Operating temperature $-40^{\circ}\text{C} \leq T_A \leq +150^{\circ}\text{C}$							
Param No.	Symbol	Characteristic	Min. <sup>(4)</sup>	Typ. <sup>(1)</sup>	Max. <sup>(5)</sup>	Units	Conditions
HDI50	IIL	<b>Input Leakage Current<sup>(2)</sup></b>					
		I/O Pins 5V Tolerant <sup>(3)</sup>	-1500	—	1500	nA	
		I/O Pins Not 5V Tolerant <sup>(3)</sup>	-700	—	700	nA	
		MCLR	-1500	—	1500	nA	
		OSCI	-750	—	750	nA	XT and HS modes

- Note 1:** Data in the “Typ.” column are at 3.3V, +25°C unless otherwise stated.  
**Note 2:** Negative current is defined as current sourced by the pin.  
**Note 3:** See the “Pin Diagrams” section for the 5V tolerant I/O pins.  
**Note 4:**  $V_{PIN} = V_{SS}$ .  
**Note 5:**  $V_{PIN} = V_{DD}$ .

**TABLE 34-16: INTERNAL FRC ACCURACY**

Operating Conditions: 3.0V to 3.6V (unless otherwise stated) Operating temperature $-40^{\circ}\text{C} \leq T_A \leq +150^{\circ}\text{C}$					
Param No.	Characteristic	Min.	Max.	Units	Conditions
<b>Internal FRC Accuracy @ FRC Frequency = 8 MHz<sup>(1)</sup></b>					
F20a	FRC	-3	+3	%	$-40^{\circ}\text{C} \leq T_A \leq +150^{\circ}\text{C}$

- Note 1:** Frequency is calibrated at +25°C and 3.3V.

**TABLE 34-17: INTERNAL LPRC ACCURACY**

Operating Conditions: 3.0V to 3.6V (unless otherwise stated) Operating temperature $-40^{\circ}\text{C} \leq T_A \leq +150^{\circ}\text{C}$					
Param No.	Characteristic	Min.	Max.	Units	Conditions
<b>LPRC @ 32 kHz</b>					
F21	LPRC	-27	+27	%	$-40^{\circ}\text{C} \leq T_A \leq +150^{\circ}\text{C}$

**TABLE 34-18: DACx MODULE SPECIFICATIONS**

Operating Conditions: 3.0V to 3.6V (unless otherwise stated) Operating temperature $-40^{\circ}\text{C} \leq T_A \leq +150^{\circ}\text{C}$							
Param No.	Symbol	Characteristic	Min.	Typ. <sup>(1)</sup>	Max.	Units	Comments
HDA03	INL	Integral Nonlinearity Error	-45	—	0	LSB	

- Note 1:** Parameters are for design guidance only and are not tested in manufacturing.

# dsPIC33CK256MP508 FAMILY

---

NOTES:

# dsPIC33CK256MP508 FAMILY

## 35.0 PACKAGING INFORMATION

### 35.1 Package Marking Information

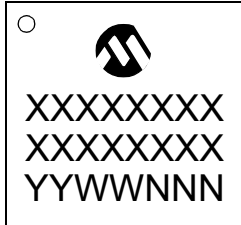
28-Lead SSOP (5.30 mm)



Example



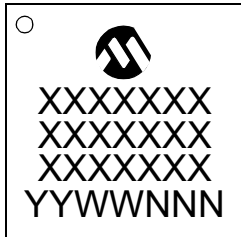
28-Lead UQFN (6x6 mm)



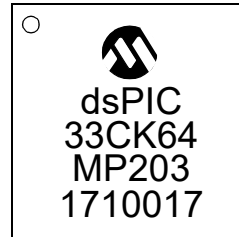
Example



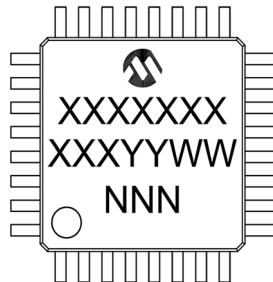
36-Lead UQFN (5x5 mm)



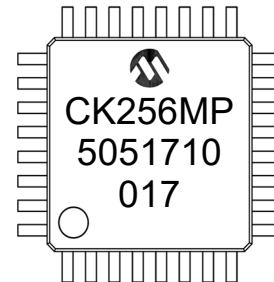
Example



48-Lead TQFP (7x7 mm)



Example



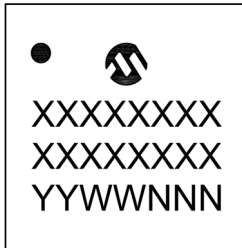
<b>Legend:</b>	XX...X	Customer-specific information
	Y	Year code (last digit of calendar year)
	YY	Year code (last 2 digits of calendar year)
	WW	Week code (week of January 1 is week '01')
	NNN	Alphanumeric traceability code
<b>Note:</b>	In the event the full Microchip part number cannot be marked on one line, it will be carried over to the next line, thus limiting the number of available characters for customer-specific information.	

# dsPIC33CK256MP508 FAMILY

---

## 35.1 Package Marking Information (Continued)

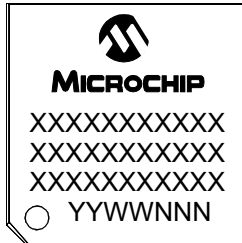
48-Lead UQFN (6x6 mm)



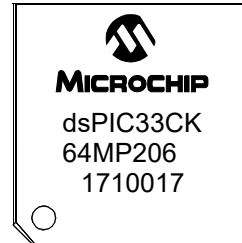
Example



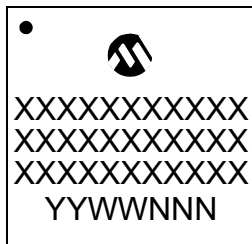
64-Lead TQFP (10x10x1 mm)



Example



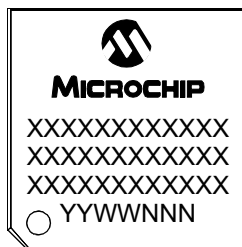
64-Lead QFN (9x9x0.9 mm)



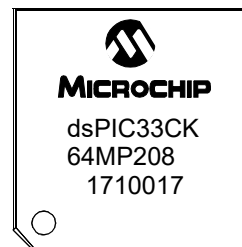
Example



80-Lead TQFP (12x12x1 mm)



Example

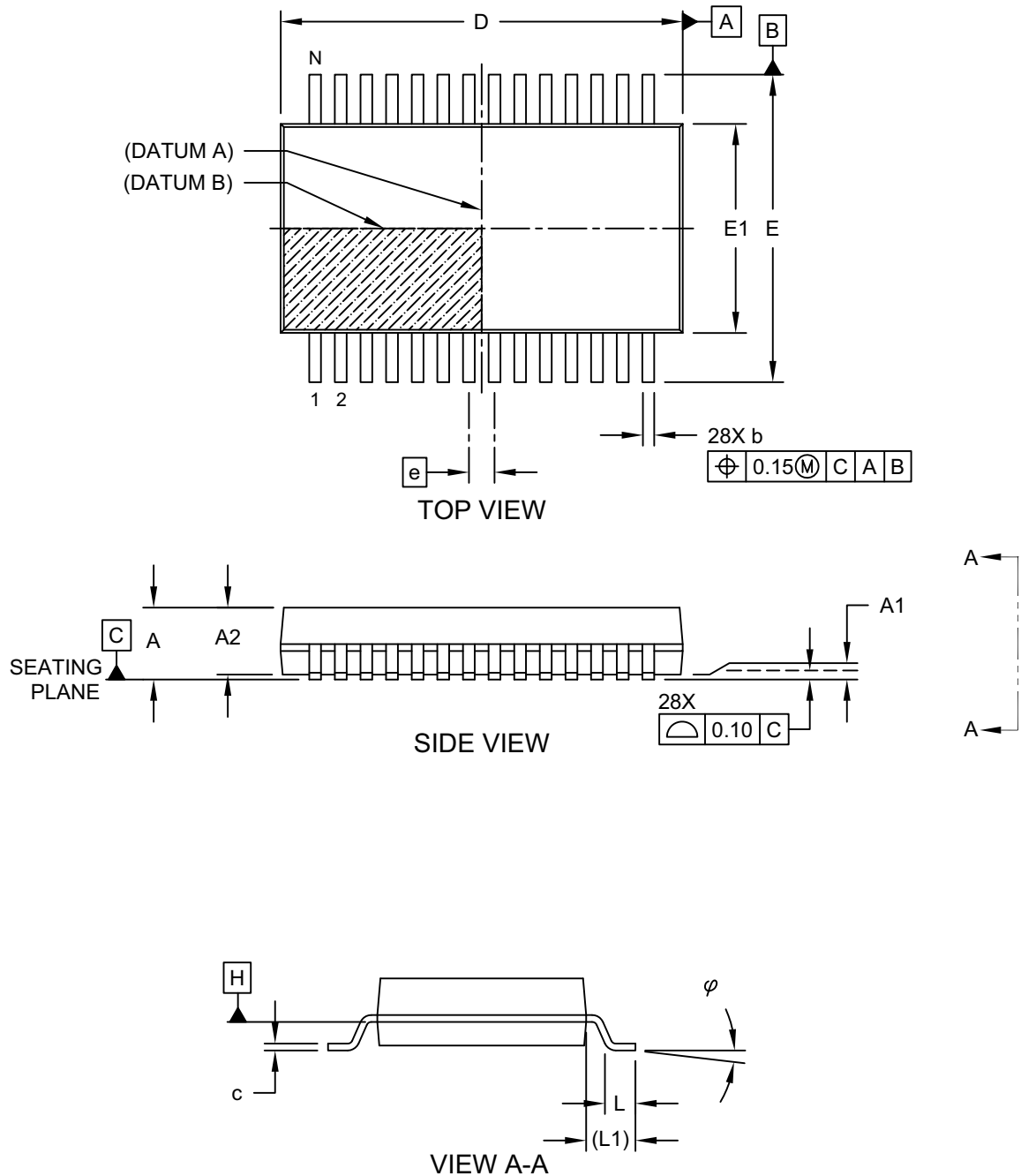


# dsPIC33CK256MP508 FAMILY

## 35.2 Package Details

### 28-Lead Plastic Shrink Small Outline (SS) - 5.30 mm Body [SSOP]

**Note:** For the most current package drawings, please see the Microchip Packaging Specification located at <http://www.microchip.com/packaging>

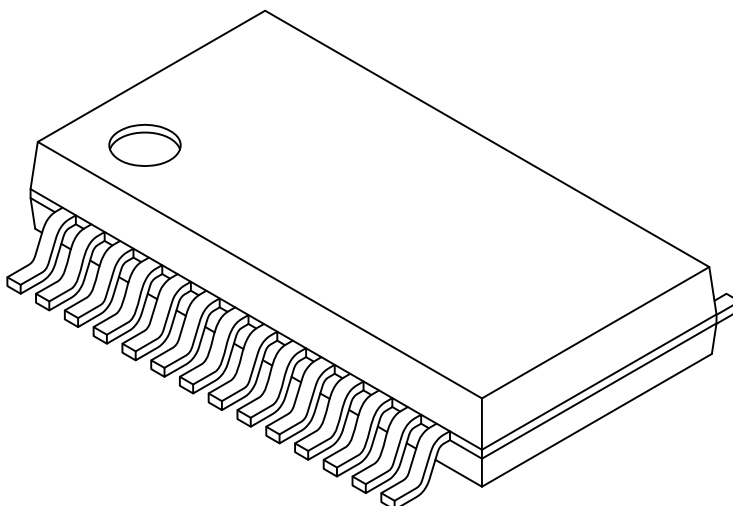


Microchip Technology Drawing C04-073 Rev C Sheet 1 of 2

# dsPIC33CK256MP508 FAMILY

## 28-Lead Plastic Shrink Small Outline (SS) - 5.30 mm Body [SSOP]

**Note:** For the most current package drawings, please see the Microchip Packaging Specification located at <http://www.microchip.com/packaging>



Dimension Limits	Units	MILLIMETERS		
		MIN	NOM	MAX
Number of Pins	N	28		
Pitch	e	0.65 BSC		
Overall Height	A	-	-	2.00
Molded Package Thickness	A2	1.65	1.75	1.85
Standoff	A1	0.05	-	-
Overall Width	E	7.40	7.80	8.20
Molded Package Width	E1	5.00	5.30	5.60
Overall Length	D	9.90	10.20	10.50
Foot Length	L	0.55	0.75	0.95
Footprint	L1	1.25 REF		
Lead Thickness	c	0.09	-	0.25
Foot Angle	$\varphi$	0°	4°	8°
Lead Width	b	0.22	-	0.38

### Notes:

1. Pin 1 visual index feature may vary, but must be located within the hatched area.
2. Dimensions D and E1 do not include mold flash or protrusions. Mold flash or protrusions shall not exceed 0.20mm per side.
3. Dimensioning and tolerancing per ASME Y14.5M

BSC: Basic Dimension. Theoretically exact value shown without tolerances.

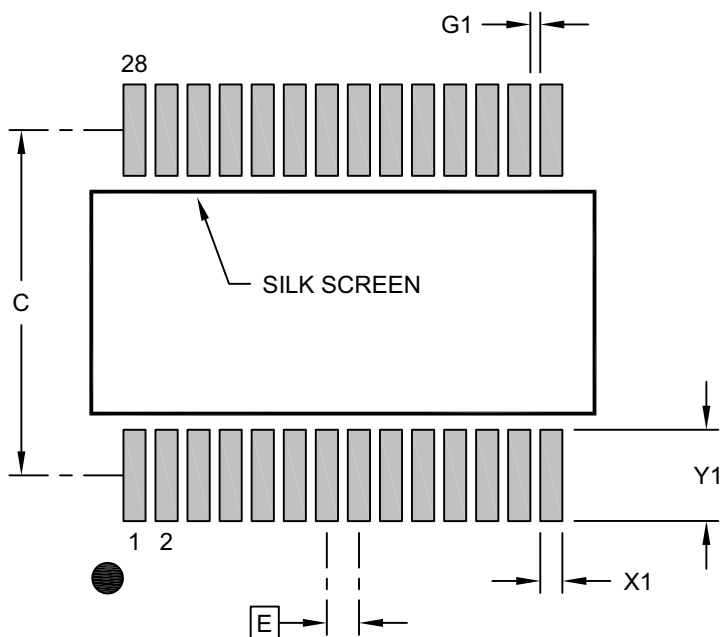
REF: Reference Dimension, usually without tolerance, for information purposes only.

Microchip Technology Drawing C04-073 Rev C Sheet 2 of 2

# dsPIC33CK256MP508 FAMILY

## 28-Lead Plastic Shrink Small Outline (SS) - 5.30 mm Body [SSOP]

**Note:** For the most current package drawings, please see the Microchip Packaging Specification located at <http://www.microchip.com/packaging>



### RECOMMENDED LAND PATTERN

Dimension Limits	Units	MILLIMETERS		
		MIN	NOM	MAX
Contact Pitch	E	0.65 BSC		
Contact Pad Spacing	C		7.00	
Contact Pad Width (X28)	X1			0.45
Contact Pad Length (X28)	Y1			1.85
Contact Pad to Center Pad (X26)	G1	0.20		

#### Notes:

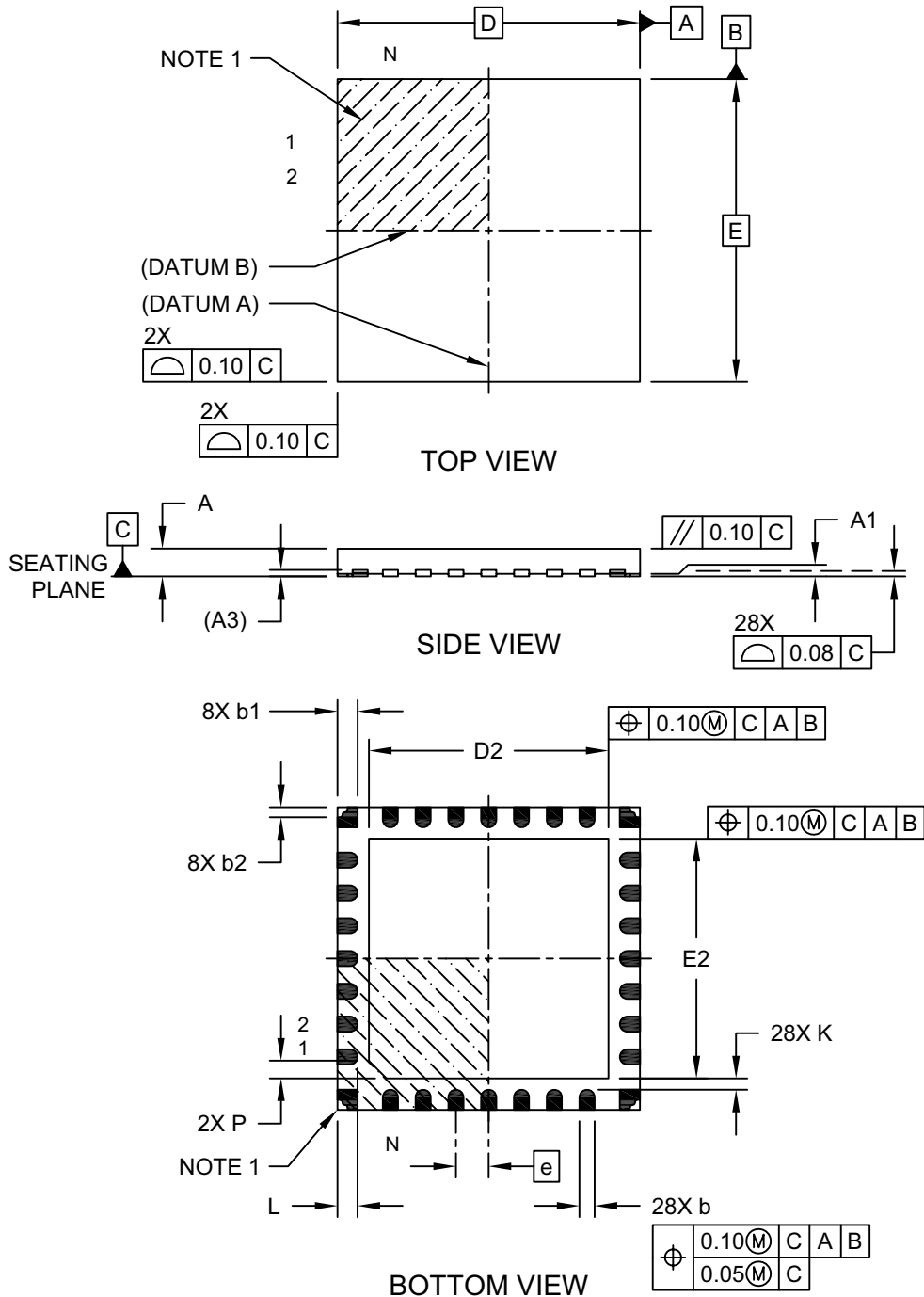
- Dimensioning and tolerancing per ASME Y14.5M  
BSC: Basic Dimension. Theoretically exact value shown without tolerances.
- For best soldering results, thermal vias, if used, should be filled or tented to avoid solder loss during reflow process

Microchip Technology Drawing C04-2073 Rev B

# dsPIC33CK256MP508 FAMILY

## 28-Lead Ultra Thin Plastic Quad Flat, No Lead Package (2N) - 6x6x0.55 mm Body [UQFN] With 4.65x4.65 mm Exposed Pad and Corner Anchors

**Note:** For the most current package drawings, please see the Microchip Packaging Specification located at <http://www.microchip.com/packaging>



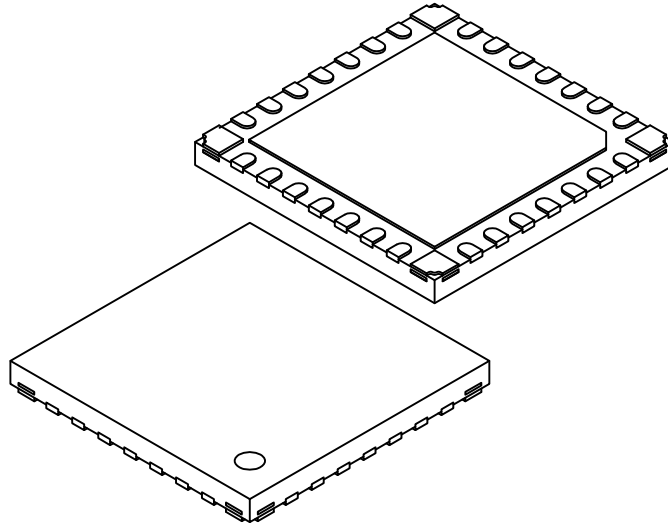
Microchip Technology Drawing C04-385 Rev C Sheet 1 of 2



# dsPIC33CK256MP508 FAMILY

## 28-Lead Ultra Thin Plastic Quad Flat, No Lead Package (2N) - 6x6x0.55 mm Body [UQFN] With 4.65x4.65 mm Exposed Pad and Corner Anchors

**Note:** For the most current package drawings, please see the Microchip Packaging Specification located at <http://www.microchip.com/packaging>



Units		MILLIMETERS		
Dimension Limits		MIN	NOM	MAX
Number of Terminals	N	28		
Pitch	e	0.65 BSC		
Overall Height	A	0.45	0.50	0.55
Standoff	A1	0.00	0.02	0.05
Terminal Thickness	A3	0.127 REF		
Overall Width	E	6.00 BSC		
Exposed Pad Width	E2	4.55	4.65	4.75
Overall Length	D	6.00 BSC		
Exposed Pad Length	D2	4.55	4.65	4.75
Exposed Pad Corner Chamfer	P	-	0.35	-
Terminal Width	b	0.25	0.30	0.35
Corner Anchor Pad	b1	0.35	0.40	0.43
Corner Pad, Metal Free Zone	b2	0.15	0.20	0.25
Terminal Length	L	0.30	0.40	0.50
Terminal-to-Exposed-Pad	K	0.20	-	-

**Notes:**

1. Pin 1 visual index feature may vary, but must be located within the hatched area.
2. Package is saw singulated
3. Dimensioning and tolerancing per ASME Y14.5M

BSC: Basic Dimension. Theoretically exact value shown without tolerances.

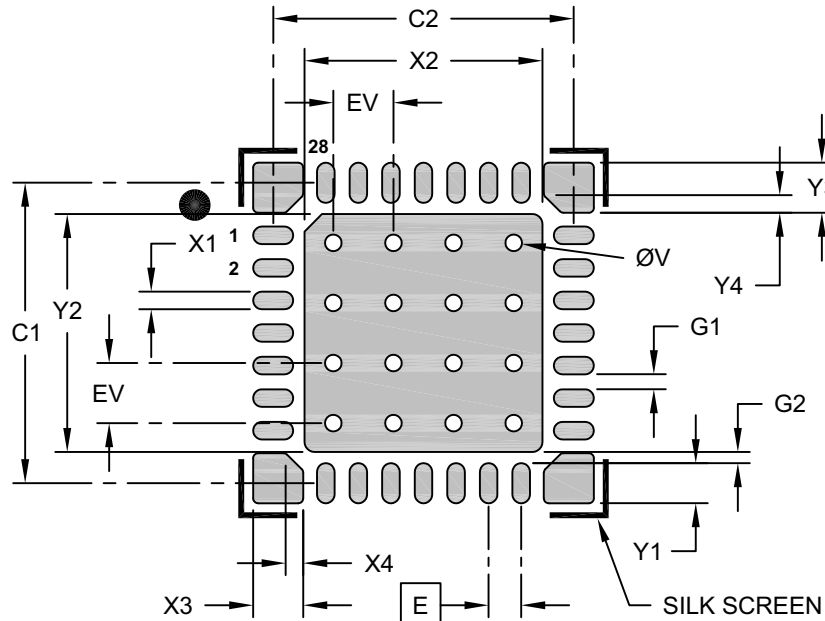
REF: Reference Dimension, usually without tolerance, for information purposes only.

Microchip Technology Drawing C04-385 Rev C Sheet 2 of 2

# dsPIC33CK256MP508 FAMILY

## 28-Lead Ultra Thin Plastic Quad Flat, No Lead Package (2N) - 6x6x0.55 mm Body [UQFN] With 4.65x4.65 mm Exposed Pad and Corner Anchors

**Note:** For the most current package drawings, please see the Microchip Packaging Specification located at <http://www.microchip.com/packaging>



RECOMMENDED LAND PATTERN

Dimension Limits	Units	MILLIMETERS		
		MIN	NOM	MAX
Contact Pitch	E	0.65 BSC		
Optional Center Pad Width	X2			4.75
Optional Center Pad Length	Y2			4.75
Contact Pad Spacing	C1		6.00	
Contact Pad Spacing	C2		6.00	
Contact Pad Width (X28)	X1			0.35
Contact Pad Length (X28)	Y1			0.80
Corner Anchor (X4)	X3			1.00
Corner Anchor (X4)	Y3			1.00
Corner Anchor Chamfer (X4)	X4			0.35
Corner Anchor Chamfer (X4)	Y4			0.35
Contact Pad to Pad (X28)	G1	0.20		
Contact Pad to Center Pad (X28)	G2	0.20		
Thermal Via Diameter	V		0.33	
Thermal Via Pitch	EV		1.20	

Notes:

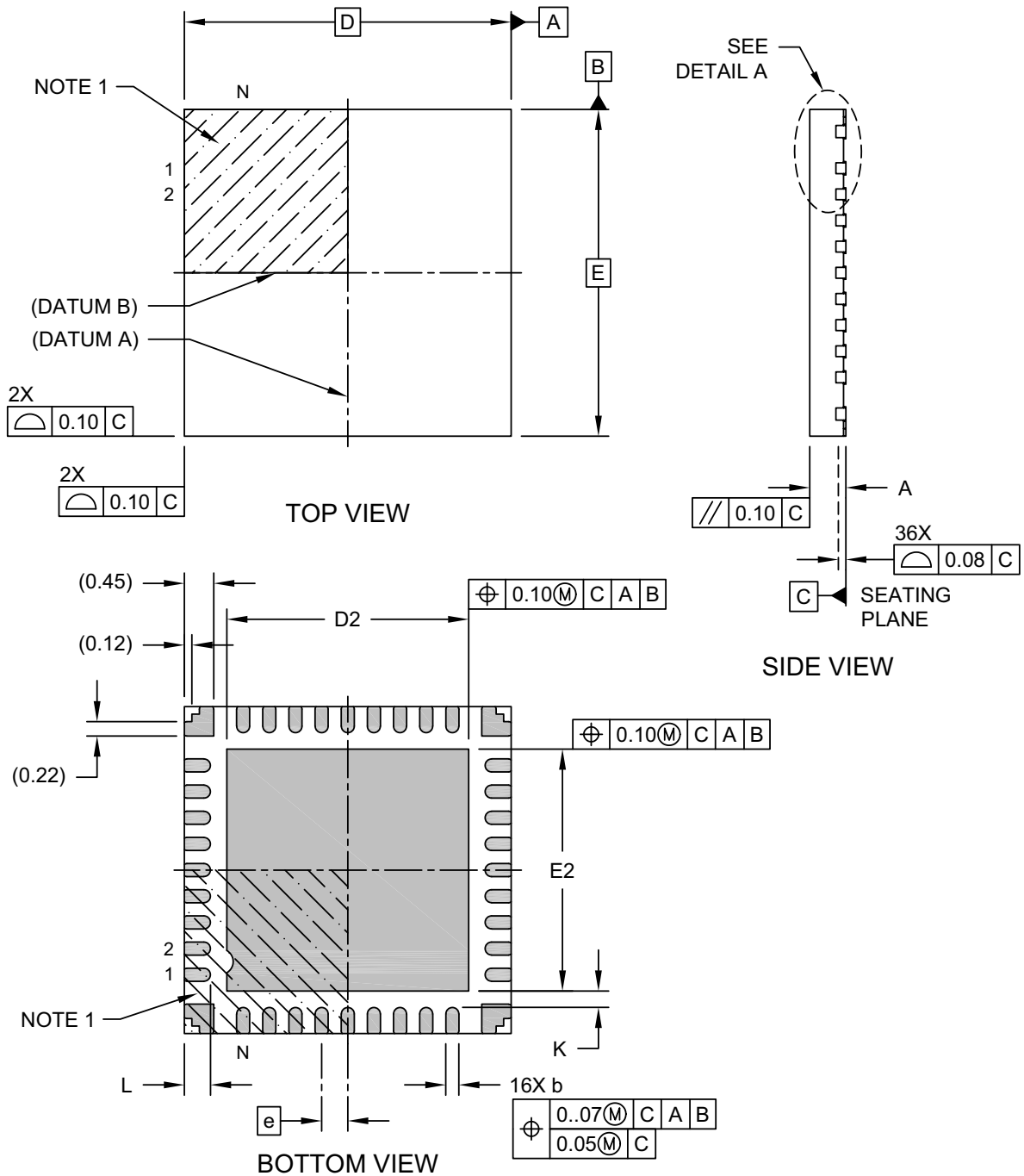
- Dimensioning and tolerancing per ASME Y14.5M  
BSC: Basic Dimension. Theoretically exact value shown without tolerances.
- For best soldering results, thermal vias, if used, should be filled or tented to avoid solder loss during reflow process

Microchip Technology Drawing C04-2385B

# dsPIC33CK256MP508 FAMILY

## 36-Lead Ultra Thin Plastic Quad Flat, No Lead Package (M5) - 5x5 mm Body [UQFN] With Corner Anchors

**Note:** For the most current package drawings, please see the Microchip Packaging Specification located at <http://www.microchip.com/packaging>

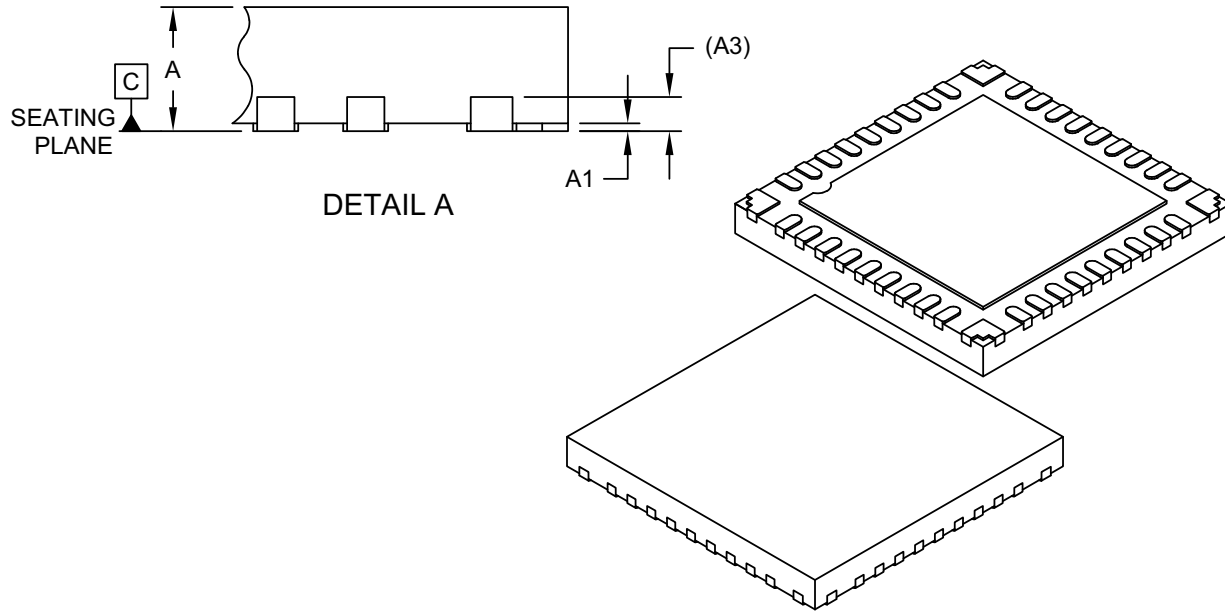


Microchip Technology Drawing C04-436-M5 Rev D Sheet 1 of 2

# dsPIC33CK256MP508 FAMILY

## 36-Lead Ultra Thin Plastic Quad Flat, No Lead Package (M5) - 5x5 mm Body [UQFN] With Corner Anchors

**Note:** For the most current package drawings, please see the Microchip Packaging Specification located at <http://www.microchip.com/packaging>



Dimension Limits	Units	MILLIMETERS		
		MIN	NOM	MAX
Number of Terminals	N	36		
Pitch	e	0.40 BSC		
Overall Height	A	0.50	0.55	0.60
Standoff	A1	0.00	0.02	0.05
Terminal Thickness	A3	0.152 REF		
Overall Length	D	5.00 BSC		
Exposed Pad Length	D2	3.60	3.70	3.80
Overall Width	E	5.00 BSC		
Exposed Pad Width	E2	3.60	3.70	3.80
Terminal Width	b	0.15	0.20	0.25
Terminal Length	L	0.30	0.40	0.50
Terminal-to-Exposed-Pad	K	0.25 REF		

**Notes:**

1. Pin 1 visual index feature may vary, but must be located within the hatched area.
2. Package is saw singulated
3. Dimensioning and tolerancing per ASME Y14.5M

BSC: Basic Dimension. Theoretically exact value shown without tolerances.

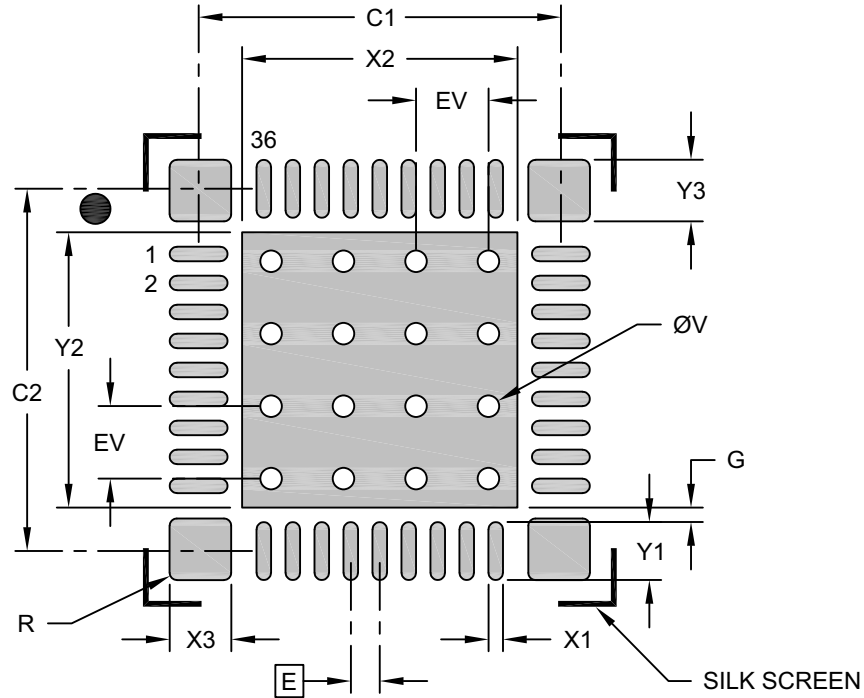
REF: Reference Dimension, usually without tolerance, for information purposes only.

Microchip Technology Drawing C04-436-M5 Rev D Sheet 2 of 2

# dsPIC33CK256MP508 FAMILY

## 36-Lead Ultra Thin Plastic Quad Flat, No Lead Package (M5) - 5x5 mm Body [UQFN] With Corner Anchors

**Note:** For the most current package drawings, please see the Microchip Packaging Specification located at <http://www.microchip.com/packaging>



### RECOMMENDED LAND PATTERN

Dimension Limits	Units	MILLIMETERS		
		MIN	NOM	MAX
Contact Pitch	E	0.40 BSC		
Center Pad Width	X2			3.80
Center Pad Length	Y2			3.80
Contact Pad Spacing	C1		5.00	
Contact Pad Spacing	C2		5.00	
Contact Pad Width (X36)	X1			0.20
Contact Pad Length (X36)	Y1			0.80
Corner Pad Width (X4)	X3			0.85
Corner Pad Length (X4)	Y3			0.85
Corner Pad Radius	R		0.10	
Contact Pad to Center Pad (X36)	G	0.20		
Thermal Via Diameter	V		0.30	
Thermal Via Pitch	EV		1.00	

**Notes:**

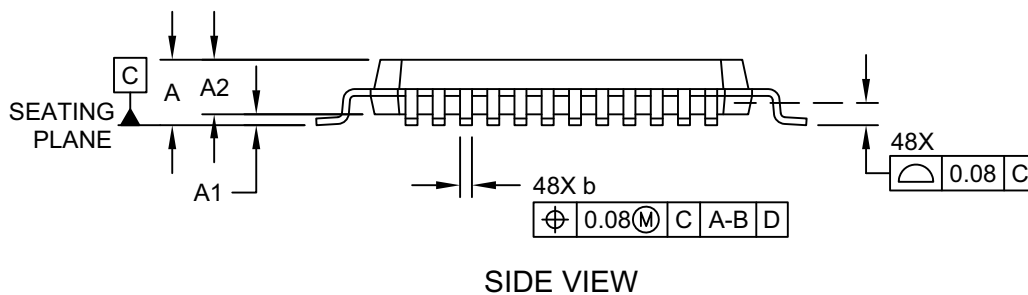
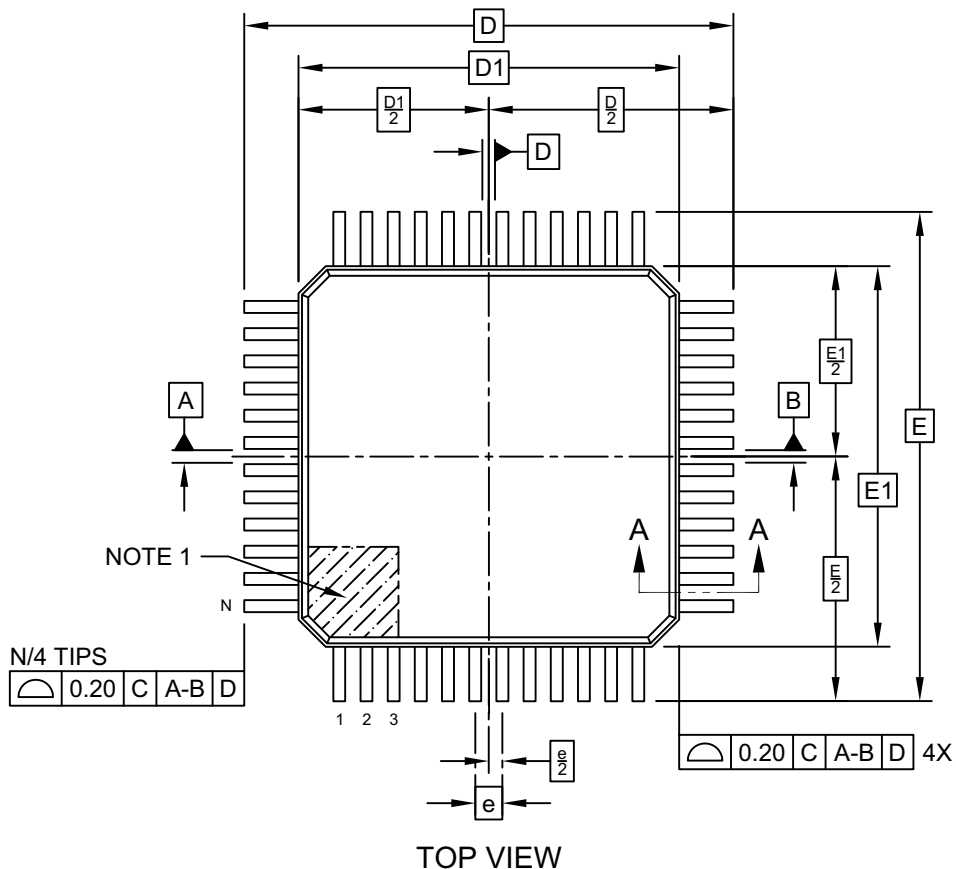
- Dimensioning and tolerancing per ASME Y14.5M  
BSC: Basic Dimension. Theoretically exact value shown without tolerances.
- For best soldering results, thermal vias, if used, should be filled or tented to avoid solder loss during reflow process

Microchip Technology Drawing C04-2436-M5 Rev D

# dsPIC33CK256MP508 FAMILY

## 48-Lead Plastic Thin Quad Flatpack (PT) - 7x7x1.0 mm Body [TQFP]

**Note:** For the most current package drawings, please see the Microchip Packaging Specification located at <http://www.microchip.com/packaging>

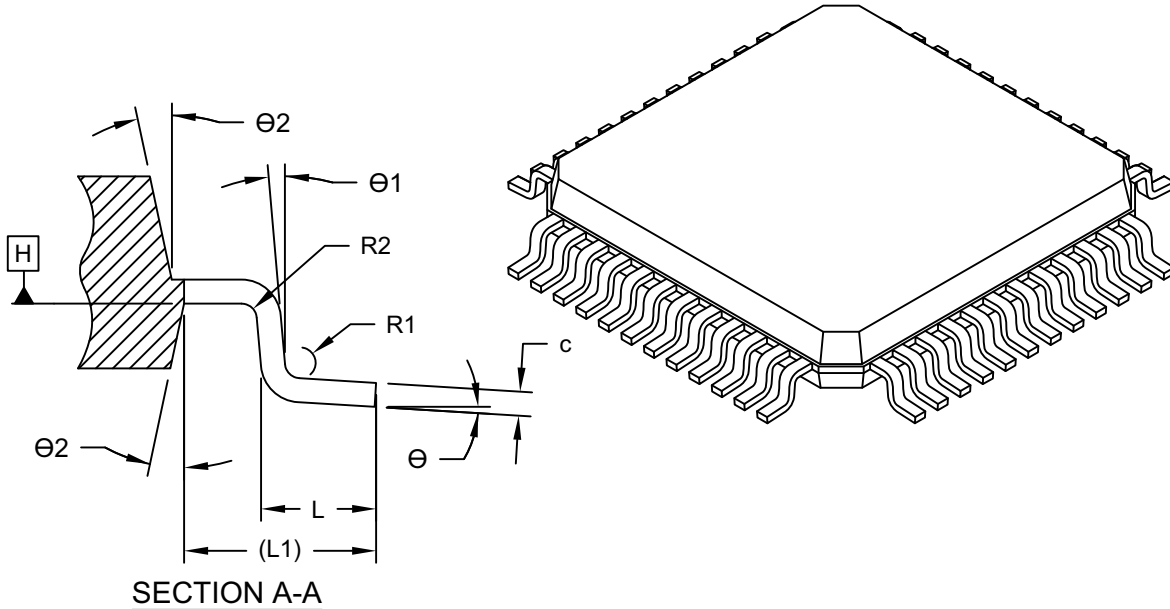


Microchip Technology Drawing C04-300-PT Rev D Sheet 1 of 2

# dsPIC33CK256MP508 FAMILY

## 48-Lead Plastic Thin Quad Flatpack (PT) - 7x7x1.0 mm Body [TQFP]

**Note:** For the most current package drawings, please see the Microchip Packaging Specification located at <http://www.microchip.com/packaging>



Dimension Limits	Units	MILLIMETERS		
		MIN	NOM	MAX
Number of Terminals	N	48		
Pitch	e	0.50 BSC		
Overall Height	A	-	-	1.20
Standoff	A1	0.05	-	0.15
Molded Package Thickness	A2	0.95	1.00	1.05
Overall Length	D	9.00 BSC		
Molded Package Length	D1	7.00 BSC		
Overall Width	E	9.00 BSC		
Molded Package Width	E1	7.00 BSC		
Terminal Width	b	0.17	0.22	0.27
Terminal Thickness	c	0.09	-	0.16
Terminal Length	L	0.45	0.60	0.75
Footprint	L1	1.00 REF		
Lead Bend Radius	R1	0.08	-	-
Lead Bend Radius	R2	0.08	-	0.20
Foot Angle	theta	0°	3.5°	7°
Lead Angle	theta 1	0°	-	-
Mold Draft Angle	theta 2	11°	12°	13°

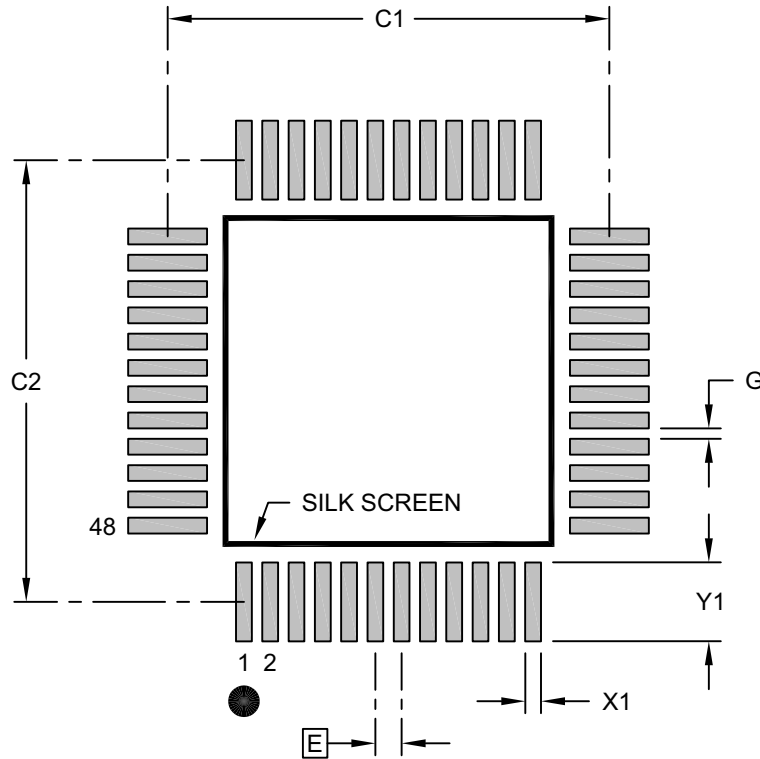
**Notes:**

- Pin 1 visual index feature may vary, but must be located within the hatched area.
- Dimensioning and tolerancing per ASME Y14.5M  
 BSC: Basic Dimension. Theoretically exact value shown without tolerances.  
 REF: Reference Dimension, usually without tolerance, for information purposes only.

# dsPIC33CK256MP508 FAMILY

## 48-Lead Plastic Thin Quad Flatpack (PT) - 7x7x1.0 mm Body [TQFP]

**Note:** For the most current package drawings, please see the Microchip Packaging Specification located at <http://www.microchip.com/packaging>



### RECOMMENDED LAND PATTERN

Dimension Limits	Units	MILLIMETERS		
		MIN	NOM	MAX
Contact Pitch	E	0.50 BSC		
Contact Pad Spacing	C1		8.40	
Contact Pad Spacing	C2		8.40	
Contact Pad Width (X48)	X1			0.30
Contact Pad Length (X48)	Y1			1.50
Distance Between Pads	G	0.20		

**Notes:**

- Dimensioning and tolerancing per ASME Y14.5M  
BSC: Basic Dimension. Theoretically exact value shown without tolerances.
- For best soldering results, thermal vias, if used, should be filled or tented to avoid solder loss during reflow process

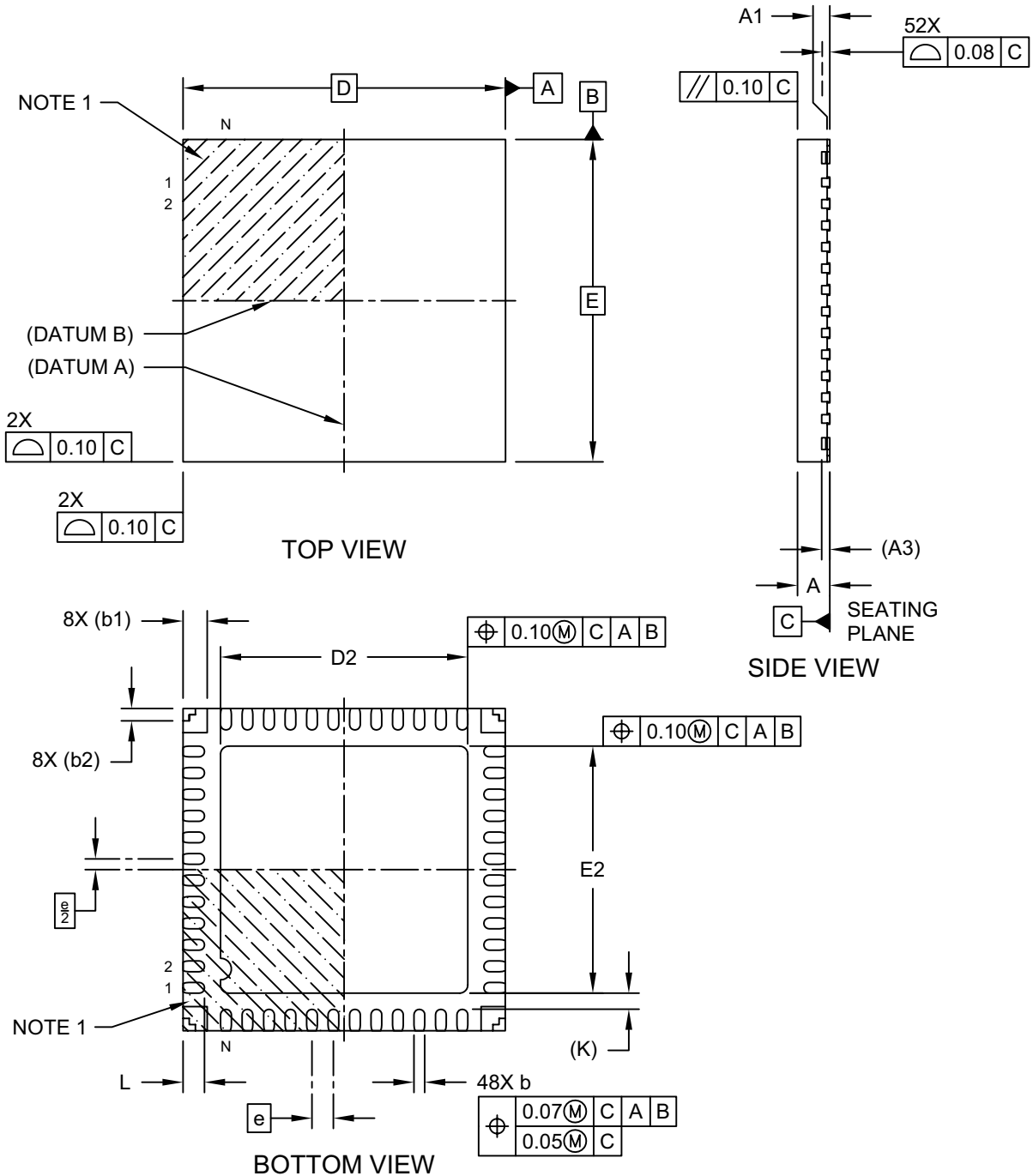
Microchip Technology Drawing C04-2300-PT Rev D



# dsPIC33CK256MP508 FAMILY

## 48-Lead Ultra Thin Plastic Quad Flat, No Lead Package (M4) - 6x6 mm Body [UQFN] With Corner Anchors and 4.6x4.6 mm Exposed Pad

**Note:** For the most current package drawings, please see the Microchip Packaging Specification located at <http://www.microchip.com/packaging>

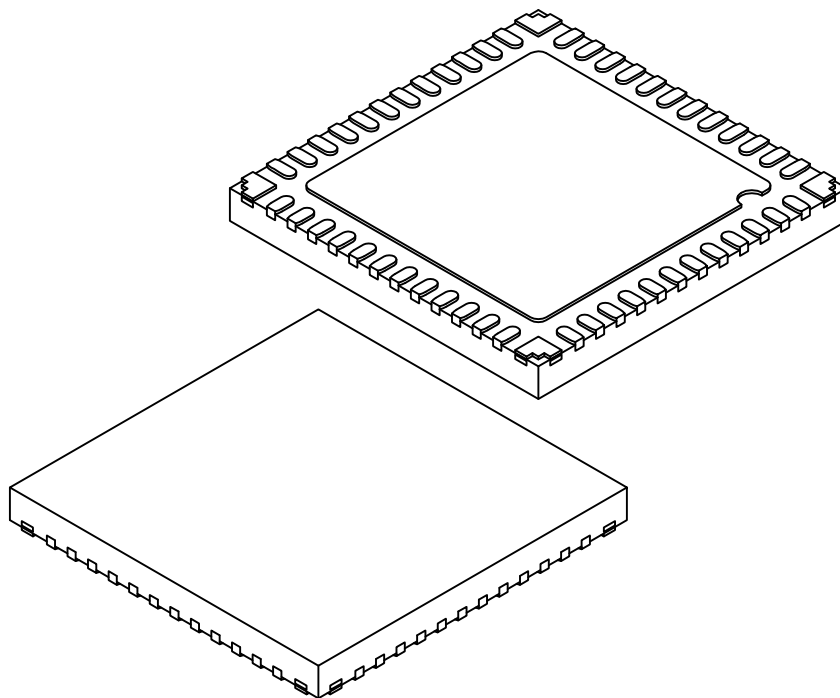


Microchip Technology Drawing C04-442A-M4 Sheet 1 of 2

# dsPIC33CK256MP508 FAMILY

## 48-Lead Ultra Thin Plastic Quad Flat, No Lead Package (M4) - 6x6 mm Body [UQFN] With Corner Anchors and 4.6x4.6 mm Exposed Pad

**Note:** For the most current package drawings, please see the Microchip Packaging Specification located at <http://www.microchip.com/packaging>



Dimension Limits	Units	MILLIMETERS		
		MIN	NOM	MAX
Number of Terminals	N	48		
Pitch	e	0.40 BSC		
Overall Height	A	0.50	0.55	0.60
Standoff	A1	0.00	0.02	0.05
Terminal Thickness	A3	0.15 REF		
Overall Length	D	6.00 BSC		
Exposed Pad Length	D2	4.50	4.60	4.70
Overall Width	E	6.00 BSC		
Exposed Pad Width	E2	4.50	4.60	4.70
Terminal Width	b	0.15	0.20	0.25
Corner Anchor Pad	b1	0.45 REF		
Corner Anchor Pad, Metal-free Zone	b2	0.23 REF		
Terminal Length	L	0.35	0.40	0.45
Terminal-to-Exposed-Pad	K	0.30 REF		

**Notes:**

1. Pin 1 visual index feature may vary, but must be located within the hatched area.
2. Package is saw singulated
3. Dimensioning and tolerancing per ASME Y14.5M

BSC: Basic Dimension. Theoretically exact value shown without tolerances.

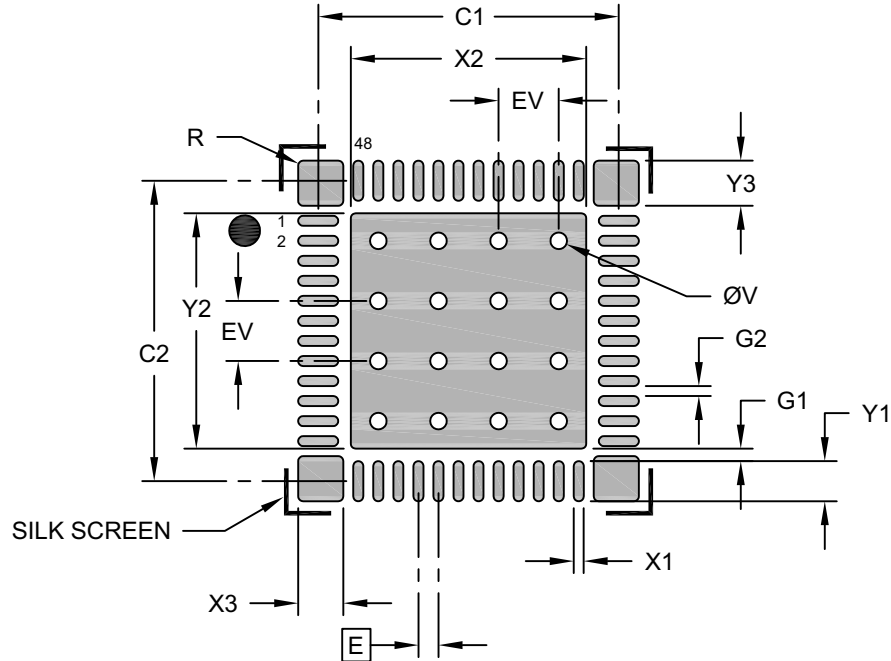
REF: Reference Dimension, usually without tolerance, for information purposes only.

Microchip Technology Drawing C04-442A-M4 Sheet 2 of 2

# dsPIC33CK256MP508 FAMILY

## 48-Lead Ultra Thin Plastic Quad Flat, No Lead Package (M4) - 6x6 mm Body [UQFN] With Corner Anchors and 4.6x4.6 mm Exposed Pad

**Note:** For the most current package drawings, please see the Microchip Packaging Specification located at <http://www.microchip.com/packaging>



### RECOMMENDED LAND PATTERN

Dimension Limits	Units	MILLIMETERS		
		MIN	NOM	MAX
Contact Pitch	E	0.40 BSC		
Center Pad Width	X2			4.70
Center Pad Length	Y2			4.70
Contact Pad Spacing	C1		6.00	
Contact Pad Spacing	C2		6.00	
Contact Pad Width (X48)	X1			0.20
Contact Pad Length (X48)	Y1			0.80
Corner Anchor Pad Width (X4)	X3			0.90
Corner Anchor Pad Length (X4)	Y3			0.90
Pad Corner Radius (X 20)	R			0.10
Contact Pad to Center Pad (X48)	G1	0.25		
Contact Pad to Contact Pad	G2	0.20		
Thermal Via Diameter	V		0.33	
Thermal Via Pitch	EV		1.20	

**Notes:**

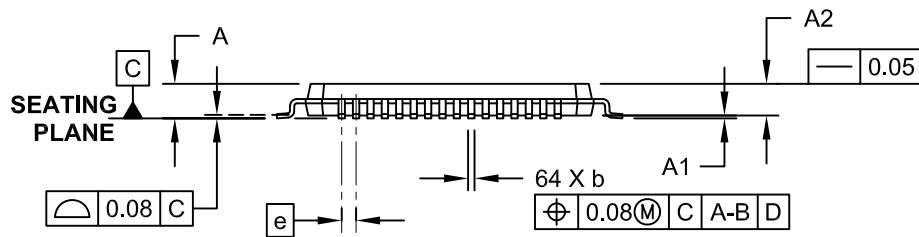
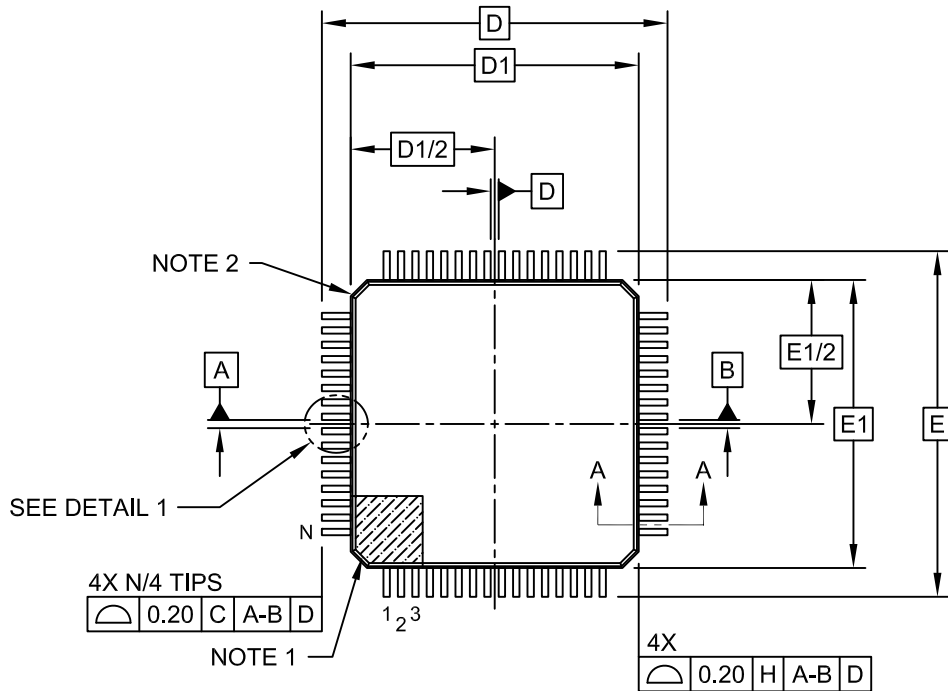
- Dimensioning and tolerancing per ASME Y14.5M  
BSC: Basic Dimension. Theoretically exact value shown without tolerances.
- For best soldering results, thermal vias, if used, should be filled or tented to avoid solder loss during reflow process

Microchip Technology Drawing C04-2442A-M4

# dsPIC33CK256MP508 FAMILY

## 64-Lead Plastic Thin Quad Flatpack (PT)-10x10x1 mm Body, 2.00 mm Footprint [TQFP]

**Note:** For the most current package drawings, please see the Microchip Packaging Specification located at <http://www.microchip.com/packaging>

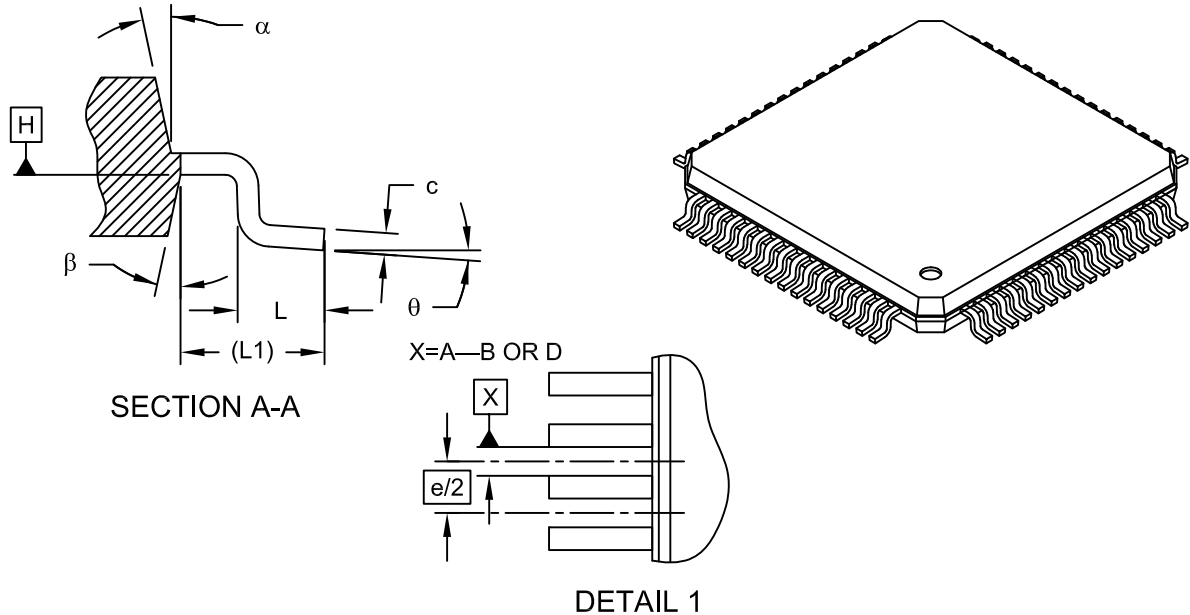


Microchip Technology Eraving C04-085-PT Rev E Sheet 1 of 2

# dsPIC33CK256MP508 FAMILY

## 64-Lead Plastic Thin Quad Flatpack (PT)-10x10x1 mm Body, 2.00 mm Footprint [TQFP]

**Note:** For the most current package drawings, please see the Microchip Packaging Specification located at <http://www.microchip.com/packaging>



Dimension Limits	Units	MILLIMETERS		
		MIN	NOM	MAX
Number of Leads	N	64		
Lead Pitch	e	0.50 BSC		
Overall Height	A	-	-	1.20
Molded Package Thickness	A2	0.95	1.00	1.05
Standoff	A1	0.05	-	0.15
Foot Length	L	0.45	0.60	0.75
Footprint	L1	1.00 REF		
Foot Angle	$\theta$	0°	3.5°	7°
Overall Width	E	12.00 BSC		
Overall Length	D	12.00 BSC		
Molded Package Width	E1	10.00 BSC		
Molded Package Length	D1	10.00 BSC		
Lead Thickness	c	0.09	-	0.20
Lead Width	b	0.17	0.22	0.27
Mold Draft Angle Top	$\alpha$	11°	12°	13°
Mold Draft Angle Bottom	$\beta$	11°	12°	13°

**Notes:**

1. Pin 1 visual index feature may vary, but must be located within the hatched area.
2. Chamfers at corners are optional; size may vary.
3. Dimensions D1 and E1 do not include mold flash or protrusions. Mold flash or protrusions shall not exceed 0.25mm per side.
4. Dimensioning and tolerancing per ASME Y14.5M

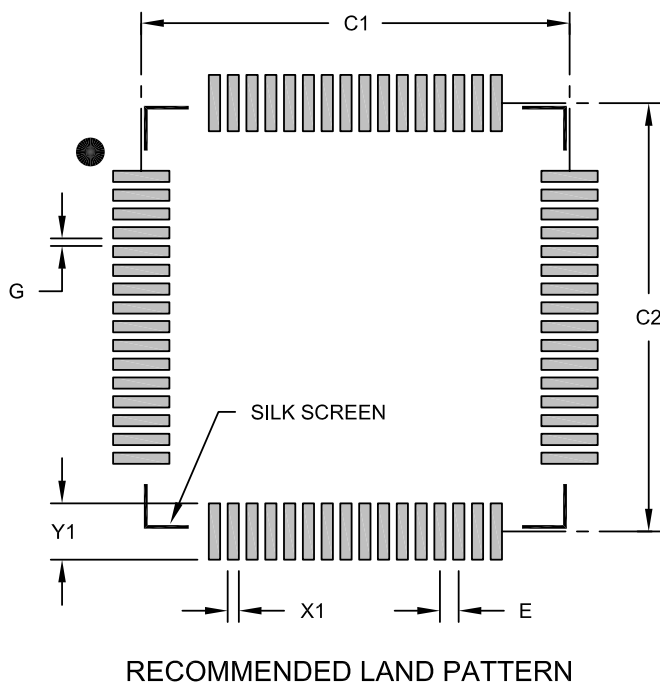
BSC: Basic Dimension. Theoretically exact value shown without tolerances.

REF: Reference Dimension, usually without tolerance, for information purposes only.

Microchip Technology Drawing C04-085-PT Rev E Sheet 2 of 2

# dsPIC33CK256MP508 FAMILY

64-Lead Plastic Thin Quad Flatpack (PT) 10x10x1 mm Body, 2.00 mm Footprint [TQFP]



Units		MILLIMETERS		
Dimension Limits		MIN	NOM	MAX
Contact Pitch	E	0.50 BSC		
Contact Pad Spacing	C1		11.40	
Contact Pad Spacing	C2		11.40	
Contact Pad Width (X64)	X1			0.30
Contact Pad Length (X64)	Y1			1.50
Distance Between Pads	G	0.20		

Notes:

1. Dimensioning and tolerancing per ASME Y14.5M

BSC: Basic Dimension. Theoretically exact value shown without tolerances.

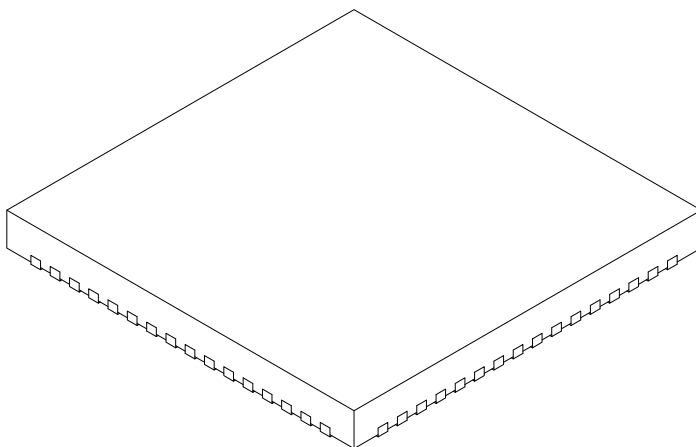
Microchip Technology Eraving C04-2085-PT Rev E



# dsPIC33CK256MP508 FAMILY

## 64-Lead Plastic Quad Flat, No Lead Package (MR) – 9x9x0.9 mm Body with 5.40 x 5.40 Exposed Pad [QFN]

**Note:** For the most current package drawings, please see the Microchip Packaging Specification located at <http://www.microchip.com/packaging>



Dimension Limits	Units	MILLIMETERS		
		MIN	NOM	MAX
Number of Pins	N	64		
Pitch	e	0.50 BSC		
Overall Height	A	0.80	0.90	1.00
Standoff	A1	0.00	0.02	0.05
Contact Thickness	A3	0.20 REF		
Overall Width	E	9.00 BSC		
Exposed Pad Width	E2	5.30	5.40	5.50
Overall Length	D	9.00 BSC		
Exposed Pad Length	D2	5.30	5.40	5.50
Contact Width	b	0.20	0.25	0.30
Contact Length	L	0.30	0.40	0.50
Contact-to-Exposed Pad	K	0.20	-	-

**Notes:**

1. Pin 1 visual index feature may vary, but must be located within the hatched area.
2. Package is saw singulated.
3. Dimensioning and tolerancing per ASME Y14.5M.

BSC: Basic Dimension. Theoretically exact value shown without tolerances.

REF: Reference Dimension, usually without tolerance, for information purposes only.

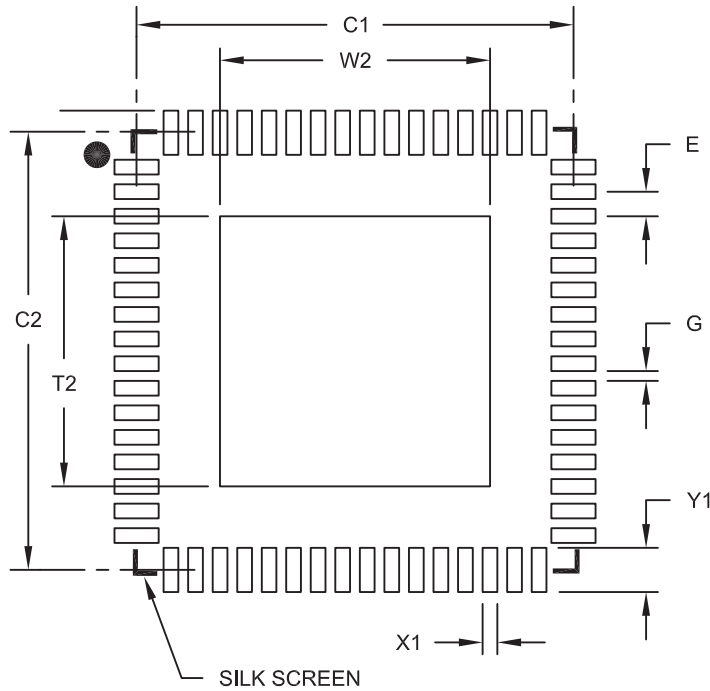
Microchip Technology Drawing C04-154A Sheet 2 of 2



# dsPIC33CK256MP508 FAMILY

64-Lead Plastic Quad Flat, No Lead Package (MR) – 9x9x0.9 mm Body [QFN]  
 With 0.40 mm Contact Length and 5.40x5.40mm Exposed Pad

**Note:** For the most current package drawings, please see the Microchip Packaging Specification located at <http://www.microchip.com/packaging>



RECOMMENDED LAND PATTERN

		MILLIMETERS		
		MIN	NOM	MAX
Contact Pitch	E	0.50 BSC		
Optional Center Pad Width	W2			5.50
Optional Center Pad Length	T2			5.50
Contact Pad Spacing	C1		8.90	
Contact Pad Spacing	C2		8.90	
Contact Pad Width (X64)	X1			0.30
Contact Pad Length (X64)	Y1			0.85
Distance Between Pads	G	0.20		

**Notes:**

1. Dimensioning and tolerancing per ASME Y14.5M

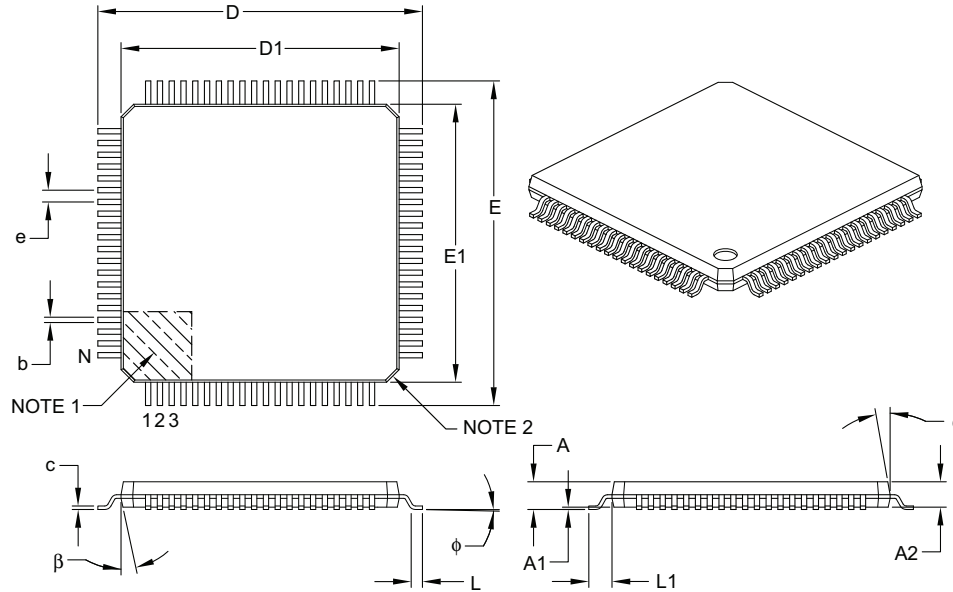
BSC: Basic Dimension. Theoretically exact value shown without tolerances.

Microchip Technology Drawing No. C04-2154A

# dsPIC33CK256MP508 FAMILY

## 80-Lead Plastic Thin Quad Flatpack (PT) – 12x12x1 mm Body, 2.00 mm [TQFP]

**Note:** For the most current package drawings, please see the Microchip Packaging Specification located at <http://www.microchip.com/packaging>



Dimension Limits	Units	MILLIMETERS		
		MIN	NOM	MAX
Number of Leads	N	80		
Lead Pitch	e	0.50 BSC		
Overall Height	A	–	–	1.20
Molded Package Thickness	A2	0.95	1.00	1.05
Standoff	A1	0.05	–	0.15
Foot Length	L	0.45	0.60	0.75
Footprint	L1	1.00 REF		
Foot Angle	φ	0°	3.5°	7°
Overall Width	E	14.00 BSC		
Overall Length	D	14.00 BSC		
Molded Package Width	E1	12.00 BSC		
Molded Package Length	D1	12.00 BSC		
Lead Thickness	c	0.09	–	0.20
Lead Width	b	0.17	0.22	0.27
Mold Draft Angle Top	α	11°	12°	13°
Mold Draft Angle Bottom	β	11°	12°	13°

**Notes:**

1. Pin 1 visual index feature may vary, but must be located within the hatched area.
2. Chamfers at corners are optional; size may vary.
3. Dimensions D1 and E1 do not include mold flash or protrusions. Mold flash or protrusions shall not exceed 0.25 mm per side.
4. Dimensioning and tolerancing per ASME Y14.5M.

BSC: Basic Dimension. Theoretically exact value shown without tolerances.

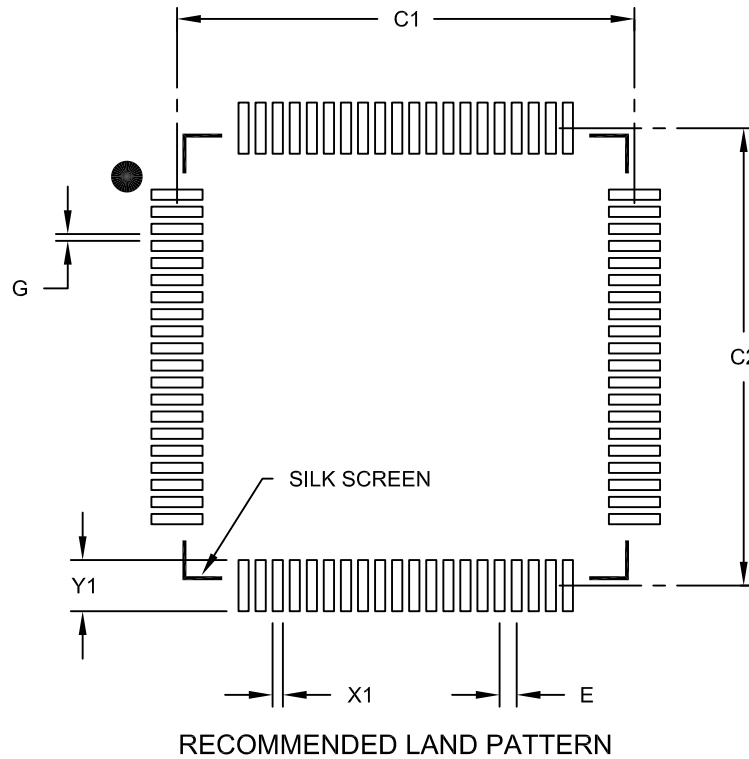
REF: Reference Dimension, usually without tolerance, for information purposes only.

Microchip Technology Drawing C04-092B

# dsPIC33CK256MP508 FAMILY

80-Lead Plastic Thin Quad Flatpack (PT)-12x12x1mm Body, 2.00 mm Footprint [TQFP]

**Note:** For the most current package drawings, please see the Microchip Packaging Specification located at <http://www.microchip.com/packaging>



Dimension Limits	Units	MILLIMETERS		
		MIN	NOM	MAX
Contact Pitch	E	0.50 BSC		
Contact Pad Spacing	C1		13.40	
Contact Pad Spacing	C2		13.40	
Contact Pad Width (X80)	X1			0.30
Contact Pad Length (X80)	Y1			1.50
Distance Between Pads	G	0.20		

Notes:

1. Dimensioning and tolerancing per ASME Y14.5M

BSC: Basic Dimension. Theoretically exact value shown without tolerances.

Microchip Technology Drawing No. C04-2092B

# dsPIC33CK256MP508 FAMILY

---

---

NOTES:

## APPENDIX A: REVISION HISTORY

### Revision A (December 2017)

This is the initial version of the document.

### Revision B (May 2018)

This revision incorporates the following updates:

- Sections:
  - Updated [Section 4.3.1 “BIST at Start-up”](#), [Section 4.3.2 “BIST at Run Time”](#), [Section 15.0 “Quadrature Encoder Interface \(QEI\)”](#), [Section 30.2 “Device Calibration and Identification”](#), [Section 30.10 “Code Protection and CodeGuard™ Security”](#) and [Section 35.1 “Package Marking Information”](#).
  - Added [Section 5.3.2 “Error Correcting Code \(ECC\)”](#) and [Section 5.5.4 “ECC Control Registers”](#).
- Tables:
  - Updated [Table 4-3](#), [Table 4-9](#), [Table 7-3](#), [Table 7-4](#), [Table 7-5](#), [Table 8-7](#), [Table 15-1](#), [Table 24-3](#), [Table 30-3](#), [Table 33-1](#), [Table 33-3](#), [Table 33-6](#), [Table 33-7](#) (was [Table 33-9](#)), [Table 33-8](#) (was [Table 33-11](#)), [Table 33-23](#), [Table 33-40](#) and [Table 33-43](#).
  - Deleted [Table 33-6](#), [Table 33-7](#), [Table 33-8](#) and [Table 33-10](#).
  - Added [Table 33-11](#), [Table 33-12](#), [Table 33-13](#) and [Table 33-14](#).
- Figures:
  - Updated [Figure 3-1](#), [Figure 4-1](#), [Figure 4-12](#), [Figure 15-2](#), [Figure 30-3](#) and [Figure 30-4](#).
- Registers:
  - Updated [Register 4-1](#), [Register 14-1](#), [Register 14-6](#), [Register 14-7](#), [Register 14-9](#), [Register 15-1](#), [Register 15-2](#), [Register 15-3](#), [Register 15-5](#), [Register 15-6](#), [Register 15-7](#), [Register 15-9](#), [Register 15-11](#), [Register 15-17](#), [Register 27-1](#), [Register 27-2](#), [Register 30-5](#) and [Register 30-7](#).
  - Added [Register 5-7](#), [Register 5-8](#), [Register 5-9](#), [Register 5-10](#), [Register 5-11](#), [Register 5-12](#), [Register 15-18](#) and [Register 15-19](#).
  - Deleted [Register 15-8](#), [Register 15-12](#) and [Register 15-20](#).
- Examples:
  - Updated [Example 29-1](#).
  - Added [Example 29-2](#).
- Equations:
  - Deleted [Equation 4-1](#).

### Revision C (July 2018)

This revision incorporates the following updates:

- Tables:
  - Updated [Table 1-1](#), [Table 33-11](#), [Table 33-21](#), [Table 33-22](#), [Table 33-27](#) and [Table 33-44](#).
- Registers:
  - Updated [Register 4-1](#), [Register 10-1](#), [Register 12-12](#), [Register 12-13](#), [Register 13-30](#), [Register 14-6](#), [Register 14-7](#), [Register 15-2](#), [Register 16-4](#), [Register 20-2](#), [Register 22-7](#), [Register 28-5](#), [Register 28-6](#), [Register 28-7](#), [Register 28-8](#), [Register 28-9](#), [Register 28-10](#) and [Register 28-11](#).
- Figures:
  - Updated [Figure 13-1](#) and [Figure 13-2](#).

### Revision D (September 2018)

This revision incorporates the following updates:

- Sections:
  - Updated [Section 18.0 “Inter-Integrated Circuit \(I<sup>2</sup>C\)”](#).
  - Added [Section 18.4 “SMBus Support”](#).
  - Updated the packaging diagrams for the 28-Lead SSOP and 28-Lead UQFN in [Section 35.0 “Packaging Information”](#).
- Tables:
  - Updated [Table 33-6](#), [Table 33-7](#), [Table 33-8](#), [Table 33-9](#), [Table 33-14](#) and [Table 33-24](#).
  - Added [Table 18-3](#).
- Registers:
  - Updated [Register 12-9](#), [Register 13-3](#), [Register 30-6](#) and [Register 30-21](#).
- Figures:
  - Updated [Figure 9-4](#).

# dsPIC33CK256MP508 FAMILY

---

## Revision E (December 2018)

This revision incorporates the following updates:

- Sections:
  - Updated the **“Operating Conditions”**, **“Safety Features”** and **“Pin Diagrams”** sections.
  - Updated **Section 5.0 “Flash Program Memory”**, **Section 5.2 “RTSP Operation”**, **Section 5.3.1 “Programming Algorithm for Flash Program Memory”**, **Section 5.3.3 “ECC Fault Injection”**, **Section 8.5.5 “Input Mapping”**, **Section 12.0 “High-Resolution PWM with Fine Edge Placement”**, **Section 23.1 “CLC Control Registers”** and the **“Product Identification System”** section.
  - Added **Section 8.5.3 “Controlling Configuration Changes”**, **Section 8.5.3.1 “Control Register Lock”**, **Section 8.5.4 “Considerations for Peripheral Pin Selection”**, **Section 9.10 “OSCCON Unlock Sequence”**, **Section 12.3 “Lock and Write Restrictions”** and **Section 34.0 “High-Temperature Electrical Characteristics”**.
- Tables:
  - Added **Table 7-1** and **Table 12-1**.
  - Updated **Table 7-2**, **Table 26-1**, **Table 33-4**, **Table 33-42** and **Table 33-44**.
- Registers:
  - Added **Register 3-3** and **Register 5-6**.
  - Updated **Register 5-5**, **Register 8-13**, **Register 9-1**, **Register 9-4**, **Register 12-1**, **Register 13-6**, **Register 16-1**, **Register 17-1** and **Register 30-14**.
- Figures:
  - Updated **Figure 17-1** and **Figure 17-2**.
- Examples:
  - Added **Example 5-1** and **Example 8-1**.

## Revision F (March 2019)

This revision incorporates the following updates:

- Sections:
  - Updated the **“Operating Conditions”**, **“Qualification Support”**, **“Absolute Maximum Ratings<sup>(1)</sup>”** and **“Product Identification System”** sections.
  - Updated **Section 9.0 “Oscillator with High-Frequency PLL”**.
  - Added **Section 9.7 “Backup Internal Fast RC (BFRC) Oscillator”**, **Section 9.8 “Reference Clock Output”**, **Section 12.4 “PWM4H/L Output on Peripheral Pin Select”**, **Section 13.2 “Temperature Sensor”** and **Section 34.0 “High-Temperature Electrical Characteristics”**.
- Tables:
  - Updated **Table 3**, **Table 4**, **Table 5**, **Table 6**, **Table 7**, **Table 8**, **Table 1-1**, **Table 4-10**, **Table 4-11**, **Table 4-16**, **Table 8-7**, **Table 10-1**, **Table 12-1**, **Table 33-4**, **Table 33-8**, **Table 33-9** and **Table 33-43**.
- Registers:
  - Updated **Register 12-14**, **Register 12-16**, **Register 12-32**, **Register 15-2** and **Register 22-2**.
- Equations:
  - Updated **Equation 18-1**.
- Figures:
  - Updated **Figure 22-1**.

Updated bit brackets from '<x>' to '[x]' and minor text edits throughout document.

# dsPIC33CK256MP508 FAMILY

## Revision G (October 2019)

This revision incorporates the following updates:

- Sections:
  - Updated CodeGuard™ Intermediate Security FRM reference in [“Referenced Sources”](#)
  - Updated [Section 1.0 “Device Overview”](#), [Section 2.4 “ICSP Pins”](#), [Section 4.1.3 “Unique Device Identifier \(UDID\)”](#), [Section 4.5.3.2 “W Address Register Selection”](#), [Section 5.3.2 “Error Correcting Code \(ECC\)”](#), [Section 10.4 “Registers”](#), [Section 14.1 “Overview”](#), [Section 20.0 “Single-Edge Nibble Transmission \(SENT\)”](#), [Section 27.0 “Operational Amplifier”](#), [Section 32.0 “Development Support”](#) and updated the 36-Lead (M5) package diagrams to Rev B.
- Tables:
  - Updated [Table 1](#), [Table 2](#), [Table 7-2](#), [Table 8-4](#), [Table 8-6](#), [Table 8-14](#), [Table 10-1](#), [Table 24-3](#), [Table 30-2](#) and [Table 33-39](#).
- Registers:
  - Updated [Register 3-2](#), [Register 7-2](#), [Register 7-3](#), [Register 7-5](#), [Register 7-7](#), [Register 8-9](#), [Register 8-10](#), [Register 8-11](#), [Register 8-12](#), [Register 11-8](#), [Register 11-28](#), [Register 11-44](#), [Register 12-13](#), [Register 12-14](#), [Register 12-17](#), [Register 13-5](#), [Register 13-19](#), [Register 13-31](#), [Register 14-9](#), [Register 20-1](#), [Register 23-3](#), [Register 24-1](#), [Register 25-3](#), [Register 25-4](#), [Register 30-6](#) and [Register 30-21](#).
- Figures:
  - Updated [Figure 4-4](#), [Figure 13-1](#) and [Figure 26-1](#).

## Revision H (June 2020)

This revision incorporates the following updates:

- Sections:
  - Updated [“Safety Features”](#), [“Qualification Support”](#), [Section 2.5 “External Oscillator Pins”](#), [Section 5.4 “Flash OTP by ICSP™ Write Inhibit”](#), [Section 9.6 “Low-Power RC \(LPRC\) Oscillator”](#), [Section 30.5 “Brown-out Reset \(BOR\)”](#) and [Section 30.7 “JTAG Interface”](#).
  - Added [“Functional Safety Readiness – ISO 26262/IEC 61508/IEC 60730”](#) and [Section 2.6 “External Oscillator Layout Guidance”](#).
- Tables:
  - Updated [Table 3](#), [Table 4](#), [Table 5](#), [Table 6](#), [Table 7](#), [Table 8](#), [Table 4-9](#), [Table 7-1](#), [Table 8-4](#), [Table 33-23](#), [Table 33-26](#), [Table 33-39](#), [Table 33-40](#), [Table 33-41](#), [Table 33-42](#) and [Table 33-44](#).
- Registers:
  - Updated [Register 13-6](#), [Register 14-1](#), [Register 14-2](#), [Register 14-3](#) and [Register 30-6](#).
- Figures:
  - Updated [Figure 1-1](#), [Figure 4-1](#), [Figure 13-1](#), [Figure 21-1](#) and [Figure 26-1](#).

## Revision J (July 2021)

This revision incorporates the following updates:

- Sections:
  - Corrected formatting in the 36-Pin Diagram.
  - Updated [Section 4.3 “BIST Overview”](#), [Section 4.3.1 “BIST at Start-up”](#), [Section 5.3.2 “Error Correcting Code \(ECC\)”](#), [Section 13.0 “High-Speed, 12-Bit Analog-to-Digital Converter \(ADC\)”](#), [Section 13.3 “Analog-to-Digital Converter Resources”](#), [Section 30.4 “On-Chip Voltage Regulators”](#) and the 36-Lead (M5) [UQFN] package drawings.
- Tables:
  - Updated [Table 7-2](#), [Table 7-3](#), [Table 7-4](#), [Table 7-5](#), [Table 33-16](#), [Table 33-39](#), [Table 33-41](#) and [Table 33-44](#).
  - Removed [Table 34-18](#): ADC Module Specifications.
  - Added [Table 13-2](#) after [Register 13-27](#).
- Registers:
  - Updated [Register 5-1](#), [Register 9-10](#), [Register 13-27](#), [Register 28-1](#), [Register 30-6](#) and [Register 30-20](#).
- Figures:
  - Updated [Figure 13-1](#) and [Figure 30-2](#).
- Examples:
  - Updated [Example 8-1](#).

# dsPIC33CK256MP508 FAMILY

---

## Revision K (June 2022)

This revision incorporates the following updates:

- Sections:
  - Updated **“Functional Safety Readiness – ISO 26262/IEC 61508/IEC 60730”**, **Section 13.2 “Temperature Sensor”**, **Section 16.0 “Universal Asynchronous Receiver Transmitter (UART)”**, **Section 28.0 “Deadman Timer (DMT)”**, **Section 29.3 “Doze Mode”**, **Section 30.5 “Brown-out Reset (BOR)”** and **Section 30.6 “Dual Watchdog Timer (WDT)”**.
  - Added **Section 9.4.1 “Primary Oscillator Pin Functionality”**.
- Tables:
  - Updated **Table 1**, **Table 2**, **Table 1-1**, **Table 4-9**, **Table 7-1**, **Table 8-1**, **Table 31-2**, **Table 33-4** and **Table 33-36**.
  - Added **Table 33-5**, **Table 33-5**, **Table 33-37** and **Table 33-38**.
- Registers:
  - Updated **Register 7-7**, **Register 11-7**, **Register 11-8**, **Register 13-28**, **Register 15-7**, **Register 15-10**, **Register 15-17**, **Register 28-1**, **Register 28-2**, **Register 28-3**, **Register 28-4**, **Register 30-13** and **Register 30-20**.
- Figures:
  - Updated **Figure 4-2**, **Figure 4-3**, **Figure 4-4**, **Figure 4-5**, **Figure 33-18** and **Figure 33-19**.
- Equations:
  - Updated **Equation 18-1**.



# dsPIC33CK256MP508 FAMILY

## INDEX

### A

Absolute Maximum Ratings .....	553, 593
AC Characteristics .....	565
Load Conditions .....	565
Alternate Interrupt Vector Table (figure) .....	103
Analog-to-Digital Converter. <i>See</i> ADC.	
Arithmetic Logic Unit (ALU).....	41
Auto-Shutdown and Gating Sources.....	449

### B

Bit-Reversed Addressing .....	76
Example .....	77
Implementation .....	76
Sequence Table (16-Entry).....	77
Block Diagrams	
16-Bit Timer1 Module.....	437
ADC Module.....	302
ADC Shared Core .....	303
Addressing for Table Registers.....	81
APLL and VCO Detail .....	189
CALL Stack Frame .....	72
CAN FD Module.....	222
CLCx Input Source Selection .....	457
CLCx Logic Function Combinatorial Options .....	456
CLCx Module .....	455
Conceptual SCCPx Modules .....	441
Constant-Current Source .....	487
CPU Core.....	32
CRC Module .....	483
Data Access from Program Space Address	
Generation .....	78
Deadman Timer Module .....	495
Dedicated ADC Core .....	303
dsPIC33CK256MP508 Core Clock Sources.....	185
dsPIC33CK256MP508 Core	
Oscillator Subsystem .....	186
dsPIC33CK256MP508 Family .....	19
Functional Direct Memory Access (DMA) .....	212
High-Speed Analog Comparator.....	332
I2Cx Module.....	404
Interleaved PFC .....	28
MCLR Pin Connections.....	26
Multiplexing Remappable Outputs for RPn .....	138
Off-Line UPS.....	30
Operational Amplifier .....	491
Oscillator Circuit Placement .....	27
Phase-Shifted Full-Bridge Converter .....	29
PLL and VCO.....	187
PMP Pinout and Connections to External Devices .....	413
Programmer's Model.....	34
PSV Read Address Generation .....	69
PTG.....	468
PWM High-Level Module .....	266
QEI Module.....	345
Recommended Minimum Connection.....	25
Reference Clock Generator .....	193
Remappable Input for U1RX.....	133
Reset System.....	97
Security Segments.....	540
Security Segments (Dual Partition).....	540
SENTx Module.....	428
Shared Port Structure .....	123
Simplified UARTx.....	364

SPIx Client, Frame Client Connection .....	402
SPIx Client, Frame Host Connection.....	402
SPIx Host, Frame Client Connection.....	402
SPIx Host, Frame Host Connection.....	401
SPIx Host/Client Connection	
(Enhanced Buffer Modes).....	401
SPIx Host/Client Connection (Standard Mode) .....	400
SPIx Module (Enhanced Mode).....	388
SPIx Module (Standard Mode) .....	387
Timer Clock Generator .....	442
Watchdog Timer (WDT).....	536
Brown-out Reset (BOR).....	515, 535
Built-In Self-Test (BIST)	
At Run Time.....	52
At Start-up .....	52
Flowchart .....	52
Overview.....	52
Built-In Self-Test. <i>See</i> BIST.	

### C

CAN FD Module	
Control Registers .....	223
Features .....	221
Message Reception .....	221
Capture/Compare/PWM/Timer	
Auto-Shutdown and Gating Sources .....	449
Auxiliary Output .....	444
Control Registers .....	445
General Purpose Timer .....	442
Input Capture Mode.....	443
Output Compare Mode .....	443
Synchronization Sources .....	448
Time Base Generator .....	442
Capture/Compare/PWM/Timer (SCCP/MCCP) .....	441
CLC	
Control Registers .....	458
Code Examples	
Configuring UART1 Input and Output Functions .....	133
Flash Write/Read.....	83
PWRSAV Instruction Syntax in Assembly.....	503
PWRSAV Instruction Syntax in C Language.....	503
Using Auxiliary PLL with Internal FRC Oscillator.....	190
Using PLL (50 MIPS) with POSC .....	192
Using Primary PLL with 8 MHz Internal FRC .....	188
Code Protection .....	515, 539
CodeGuard Security .....	515, 539
Comparator/DAC	
Control Registers .....	333
Features Overview .....	333
Configurable Logic Cell (CLC).....	455
Configurable Logic Cell. <i>See</i> CLC.	
Configuration Bits .....	515
Bit Values for Clock Selection .....	195
Controller Area Network. <i>See</i> CAN.	
CPU .....	31
Addressing Modes.....	31
Control Registers.....	36
Data Space Addressing.....	31
Instruction Set.....	31
Registers .....	31
Resources .....	35
CRC	
Control Registers.....	484

# dsPIC33CK256MP508 FAMILY

Current Bias Generator		I2Cx Bus Data Timing Requirements	
Control Registers .....	488	(Client Mode) .....	583
Current Bias Generator (CBG) .....	487	I2Cx Bus Data Timing Requirements	
Current Bias Generator. <i>See</i> CBG.		(Host Mode) .....	581
Customer Change Notification Service .....	641	Idle Current (IDLE) .....	557
Customer Notification Service .....	641	Internal FRC Accuracy .....	568
Customer Support .....	641	Internal LPRC Accuracy .....	568
Cyclic Redundancy Check. <i>See</i> CRC.		Op Amp Delta Current .....	561
<b>D</b>		Operating Current (IDD) .....	556
Data Address Space .....	47	Operating Voltage Specifications .....	555
Memory Map for dsPIC33CK128MPX0X Devices .....	50	Operational Amplifier Specifications .....	591
Memory Map for dsPIC33CK256MPX0X Devices .....	49	PLL Timing Specifications .....	567
Memory Map for dsPIC33CK64MPX0X and		Power-Down Current (IPD) .....	558
dsPIC33CK32MPX0X Devices .....	51	Program Memory .....	564
Near Data Space .....	48	PWM Delta Current .....	559
Organization, Alignment .....	47	SPIx Client Mode (Full-Duplex, CKE = 0, CKP = x,	
SFR Space .....	48	SMP = 0) Timing Requirements .....	577
Width .....	47	SPIx Client Mode (Full-Duplex, CKE = 1, CKP = x,	
Data Space		SMP = 0) Timing Requirements .....	579
Extended X .....	72	SPIx Host Mode (Full-Duplex, CKE = 0, CKP = x,	
Paged Data Memory Space (figure) .....	70	SMP = 1) Timing Requirements .....	575
Paged Memory Scheme .....	69	SPIx Host Mode (Full-Duplex, CKE = 1, CKP = x,	
DC Characteristics		SMP = 1) Timing Requirements .....	574
Operating MIPS vs. Voltage .....	554	SPIx Host Mode (Half-Duplex, Transmit Only)	
Deadman Timer (DMT) .....	495	Timing Requirements .....	573
Control Registers .....	496	SPIx Maximum Data/Clock Rate Summary .....	572
Deadman Timer. <i>See</i> DMT.		UARTx I/O Timing Requirements .....	584
Development Support .....	551	Voltage Regulator Specifications .....	555
Device Calibration .....	532	Watchdog Timer Delta Current ( $\Delta$ IWDT) .....	559
and Identification .....	532	<b>Equations</b>	
Device Overview .....	19	AFPLLO Calculation .....	190
Direct Memory Access Controller. <i>See</i> DMA.		AFVCO Calculation .....	190
DMA		Calculating Frequency Output .....	194
Channel Trigger Sources .....	219	FPLLO Calculation .....	188
Control Registers .....	215	Frame Time Calculations .....	429
Peripheral Module Disable (PMD) .....	215	FVCO Calculation .....	188
Summary of Operations .....	213	I <sup>2</sup> C Baud Rate Reload Calculation .....	405
Types of Data Transfers .....	214	Relationship Between Device and	
Typical Setup .....	215	SPIx Clock Speed .....	402
Doze Mode .....	505	SYNCMINx and SYNCMAXx Calculations .....	430
DSP Engine .....	41	Tick Period Calculation .....	429
Dual Watchdog Timer (Dual WDT) .....	536	<b>Errata</b> .....	15
<b>E</b>		<b>Error Correcting Code (ECC)</b> .....	84
ECC		Fault Injection .....	84
Control Registers .....	94	<b>F</b>	
Electrical Characteristics .....	553	Flash OTP by ICSP Write Inhibit .....	85
AC .....	565	Activation .....	85
ADC Delta Current .....	560	Flash Program Memory	
ADC Specifications .....	587	and Table Instructions .....	81
APLL Delta Current .....	560	Control Registers .....	88
APLL Timing Specifications .....	567	Dual Partition Flash Configuration .....	86
Comparator + DAC Delta Current .....	561	Operations .....	83
Constant-Current Source Specifications .....	591	RTSP Operation .....	82
DACx Output (DACOUT1 Pin) Specifications .....	590	Flexible Configuration .....	515
DACx Specifications .....	590	<b>G</b>	
Doze Current (IDOZE) .....	558	Getting Started Guidelines .....	25
External Clock Requirements .....	566	Connection Requirements .....	25
High-Speed Analog Comparator Specifications .....	589	Decoupling Capacitors .....	25
High-Speed PWMx Timing Requirements .....	571	External Oscillator Layout Guidance .....	27
I/O Pin Input Injection Current Specifications .....	563	External Oscillator Pins .....	26
I/O Pin Input Specifications .....	562	ICSP Pins .....	26
I/O Pin Output Specifications .....	563	Master Clear (MCLR) Pin .....	26
I/O Timing Requirements .....	569		

# dsPIC33CK256MP508 FAMILY

Oscillator Value Conditions on Start-up .....	28	Instruction Addressing Modes .....	73
Targeted Applications .....	28	File Register Instructions .....	73
Unused I/Os .....	28	Fundamental Modes Supported .....	73
<b>H</b>		MAC Instructions .....	74
High-Resolution PWM (HSPWM) with		MCU Instructions .....	73
Fine Edge Placement .....	265	Move and Accumulator Instructions .....	74
High-Speed Analog Comparator with		Other Instructions .....	74
Slope Compensation DAC .....	331	Instruction Set Summary .....	541
High-Speed, 12-Bit Analog-to-Digital Converter (ADC) ....	301	Overview .....	544
Channel Trigger Source to Register Association .....	326	Symbols Used in Opcode Descriptions .....	542
Control Registers .....	305	Instruction-Based Power-Saving Modes .....	503
Differential-Mode .....	304	Idle .....	504
Features Overview .....	301	Sleep .....	504
Resources .....	304	Inter-Integrated Circuit. See I <sup>2</sup> C.	
Temperature Sensor .....	304	Internet Address .....	641
High-Temperature DC Characteristics		Interrupt Controller	
ADC Delta Current .....	600	Alternate Interrupt Vector Table (AIVT) .....	101
APLL Delta Current .....	599	Control and Status Registers .....	112
Comparator + DAC Delta Current .....	600	INTCON1 .....	112
DACx Specifications .....	601	INTCON2 .....	112
Doze Current (IDOE) .....	598	INTCON3 .....	112
I/O Pin Input Specifications .....	601	INTCON4 .....	112
Idle Current (IDLE) .....	597	INTTREG .....	112
Internal FRC Accuracy .....	601	Interrupt Vector Details .....	105
Internal LPRC Accuracy .....	601	Interrupt Vector Table (IVT) .....	101
Op Amp Delta Current .....	600	Reset Sequence .....	101
Operating Current (IDD) .....	596	Resources .....	112
Operating MIPS vs. Voltage .....	594	Trap Vector Details .....	104
Operating Voltage Specifications .....	595	Interrupt Vector Table (figure) .....	102
Power-Down Current (IPD) .....	598	Interrupts Coincident with Power Save Instructions .....	504
PWM Delta Current .....	599	<b>J</b>	
Thermal Operating Conditions .....	594	JTAG Boundary Scan Interface .....	515
Thermal Packaging Characteristics .....	594	JTAG Interface .....	539
Watchdog Timer Delta Current (ΔIWDT) .....	598	<b>L</b>	
High-Temperature Electrical Characteristics .....	593	Low-Power Sleep Modes (table) .....	504
HSPWM		<b>M</b>	
Architecture .....	266	Memory Organization .....	43
Control Registers .....	268	Resources .....	54
Lock and Write Restrictions .....	267	Microchip Internet Website .....	641
PWM Output Availability (table) .....	265	Modulo Addressing .....	75
<b>I</b>		Applicability .....	76
I/O Ports		Operation Example .....	75
Configuring Analog/Digital Port Pins .....	124	Start and End Address .....	75
Control Registers .....	124	W Address Register Selection .....	75
Helpful Tips .....	143	<b>O</b>	
Parallel I/O (PIO) .....	121	Operational Amplifier .....	491
Resources .....	144	Control Registers .....	492
Write/Read Timing .....	124	Oscillator	
I <sup>2</sup> C		Auxiliary PLL .....	189
Client Address Masking .....	405	Backup Internal Fast RC (BFRC) .....	193
Clock Rates .....	405	Configuration .....	195
Communicating as Host in		Control Registers .....	196
Single Host Environment .....	403	CPU Clocking .....	191
Control Registers .....	407	Internal Fast RC (FRC) .....	193
Reserved Addresses .....	406	Low-Power RC (LPRC) .....	193
Setting Baud Rate as Bus Host .....	405	OSCCON Unlock Sequence .....	195
SMBus Support .....	406	Primary (POSC) .....	192
In-Circuit Debugger .....	539	Pin Functionality .....	192
In-Circuit Emulation .....	515	Primary PLL .....	187
In-Circuit Serial Programming (ICSP) .....	515, 539	Reference Clock Output .....	193
Input Change Notification (ICN) .....	131	Oscillator with High-Frequency PLL .....	185

# dsPIC33CK256MP508 FAMILY

## P

Packaging .....	603
Details .....	605
Marking .....	603
Parallel Master Port (PMP) .....	413
Peripheral Module Disable (PMD).....	505
Peripheral Pin Select (PPS).....	131
Available Peripherals .....	131
Available Pins .....	131
Control Registers .....	148
Controlling Configuration Changes .....	132
Input Mapping .....	132
Output Mapping .....	138
Output Selection for Remappable Pins .....	141
Remappable Output Pin Registers .....	139
Remappable Pin Inputs.....	134
Selectable Input Sources .....	136
Peripheral Trigger Generator (PTG) .....	467
Peripheral Trigger Generator. <i>See</i> PTG.	
Pin and ANSELx Availability .....	122
Pinout I/O Descriptions (table) .....	20
PMP	
Control Registers .....	414
Power-Saving Features.....	503
Clock Frequency and Switching.....	503
Resources .....	505
Program Address Space	
Memory Map for dsPIC33CK128MP50X/20X	
Devices .....	44
Memory Map for dsPIC33CK256MP50X/20X	
Devices .....	44
Memory Map for dsPIC33CK32MP50X/20X	
Devices .....	45
Memory Map for dsPIC33CK64MP50X/20X	
Devices .....	45
Memory Map for dsPIC33CKXXXMP50X/20X	
Devices .....	43
Program Memory	
Address Space.....	43
Construction.....	78
Data Access from Program Memory Using	
Table Instructions .....	79
Table Read High Instructions (TBLRDH) .....	79
Table Read Low Instructions (TBLRDL) .....	79
Interfacing with Data Memory Spaces .....	78
Organization .....	46
Reset Vector .....	46
Programmer's Model.....	33
Register Descriptions .....	33
PTG	
Command Options .....	479
Control Registers .....	469
Features .....	467
Input Descriptions .....	481
Output Descriptions .....	481
Step Command Format/Description .....	478
Q	
QE1	
Control and Status Registers .....	346
Truth Table .....	344
Quadrature Encoder Interface (QE1).....	343
Quadrature Encoder Interface. <i>See</i> QE1.	

## R

Referenced Sources .....	16
Register Maps	
Configuration .....	517
Interrupt Enable .....	109
Interrupt Flag .....	109
Interrupt Priority .....	110
PMD .....	513
PORTA .....	145
PORTB .....	145
PORTC .....	146
PORTD .....	146
PORTE .....	147
PPS Input Control .....	183
PPS Output Control .....	184
Registers	
ACLKCON1 (Auxiliary Clock Control).....	203
ADCMPxCON (ADC Digital Comparator x	
Control).....	327
ADCMPxENH (ADC Digital Comparator x	
Channel Enable High) .....	328
ADCMPxENL (ADC Digital Comparator x	
Channel Enable Low) .....	328
ADCON1H (ADC Control 1 High) .....	306
ADCON1L (ADC Control 1 Low).....	305
ADCON2H (ADC Control 2 High) .....	308
ADCON2L (ADC Control 2 Low).....	307
ADCON3H (ADC Control 3 High) .....	310
ADCON3L (ADC Control 3 Low).....	309
ADCON4H (ADC Control 4 High) .....	312
ADCON4L (ADC Control 4 Low).....	311
ADCON5H (ADC Control 5 High) .....	314
ADCON5L (ADC Control 5 Low).....	313
ADCORExH (Dedicated ADC Core x	
Control High) .....	316
ADCORExL (Dedicated ADC Core x	
Control Low) .....	315
ADEIEH (ADC Early Interrupt Enable High) .....	318
ADEIEL (ADC Early Interrupt Enable Low).....	318
ADEISTATH (ADC Early Interrupt Status High) .....	319
ADEISTATL (ADC Early Interrupt Status Low).....	319
ADFLxCON (ADC Digital Filter x Control) .....	329
ADIEH (ADC Interrupt Enable High).....	322
ADIEL (ADC Interrupt Enable Low) .....	322
ADLVLTRGH (ADC Level-Sensitive Trigger	
Control High) .....	317
ADLVLTRGL (ADC Level-Sensitive Trigger	
Control Low) .....	317
ADM0D0H (ADC Input Mode Control 0 High).....	320
ADM0D0L (ADC Input Mode Control 0 Low) .....	320
ADM0D1H (ADC Input Mode Control 1 High).....	321
ADM0D1L (ADC Input Mode Control 1 Low) .....	321
ADSTATH (ADC Data Ready Status High) .....	323
ADSTATL (ADC Data Ready Status Low).....	323
ADTRIGnL/ADTRIGnH (ADC Channel Trigger n(x)	
Selection Low/High).....	324
AMP0CON1H (Op Amp Control High).....	493
AMP0CON1L (Op Amp Control Low).....	492
ANSELx (Analog Select for PORTx).....	124
APLLDIV1 (APLL Output Divider).....	205
APLLFBD1 (APLL Feedback Divider).....	204
BIASCON (Current Bias Generator Control) .....	488
C1BDIAG0H (CAN Bus Diagnostics 0 High) .....	257

# dsPIC33CK256MP508 FAMILY

C1BDIAG0L (CAN Bus Diagnostics 0 Low).....	257	C1TXQCONL (CAN Transmit Queue Control Low).....	243
C1BDIAG1H (CAN Bus Diagnostics 1 High).....	258	C1TXQSTA (CAN Transmit Queue Status).....	244
C1BDIAG1L (CAN Bus Diagnostics 1 Low).....	259	C1TXQUAH (CAN Transmit Queue User Address High).....	255
C1CONH (CAN Control High).....	223	C1TXQUAL (CAN Transmit Queue User Address Low).....	255
C1CONL (CAN Control Low).....	225	C1TXREQH (CAN Transmit Request High).....	240
C1DBTFCGH (CAN Data Bit Time Configuration High).....	227	C1TXREQL (CAN Transmit Request Low).....	240
C1DBTFCGL (CAN Data Bit Time Configuration Low).....	227	C1VECH (CAN Interrupt Code High).....	232
C1FIFOBAH (CAN Message Memory Base Address High).....	241	C1VECL (CAN Interrupt Code Low).....	233
C1FIFOBAL (CAN Message Memory Base Address Low).....	241	CANCLKCON (CAN Clock Control).....	206
C1FIFOCONHx (CAN FIFO Control x High).....	245	CCPxCON1H (CCPx Control 1 High).....	447
C1FIFOCONLx (CAN FIFO Control x Low).....	246	CCPxCON1L (CCPx Control 1 Low).....	445
C1FIFOSTAx (CAN FIFO Status x).....	248	CCPxCON2H (CCPx Control 2 High).....	450
C1FIFOUAHx (CAN FIFO User Address x High).....	253	CCPxCON2L (CCPx Control 2 Low).....	449
C1FIFOUALx (CAN FIFO User Address x Low).....	253	CCPxCON3H (CCPx Control 3 High).....	452
C1FLTCONxH (CAN Filter Control x High).....	260	CCPxCON3L (CCPx Control 3 Low).....	451
C1FLTCONxL (CAN Filter Control x Low).....	261	CCPxSTATL (CCPx Status).....	453
C1FLTOBJxH (CAN Filter Object x High).....	262	CLCxCONH (CLCx Control High).....	459
C1FLTOBJxL (CAN Filter Object x Low).....	262	CLCxCONL (CLCx Control Low).....	458
C1INTH (CAN Interrupt High).....	234	CLCxGLSH (CLCx Gate Logic Input Select High)....	464
C1INTL (CAN Interrupt Low).....	235	CLCxGLSL (CLCx Gate Logic Input Select Low)....	462
C1MASKxH (CAN Mask x High).....	263	CLCxSEL (CLCx Input MUX Select).....	460
C1MASKxL (CAN Mask x Low).....	263	CLKDIV (Clock Divider).....	198
C1NBTCFGH (CAN Nominal Bit Time Configuration High).....	226	CMBTRIGH (Combinational Trigger High).....	273
C1NBTCFGL (CAN Nominal Bit Time Configuration Low).....	226	CMBTRIGL (Combinational Trigger Low).....	272
C1RXIFH (CAN Receive Interrupt Status High).....	236	CNCONx (Change Notification Control for PORTx).....	128
C1RXIFL (CAN Receive Interrupt Status Low).....	236	CNEN0x (Interrupt Change Notification Enable for PORTx).....	128
C1RXOVIFH (CAN Receive Overflow Interrupt Status High).....	237	CNEN1x (Interrupt Change Notification Edge Select for PORTx).....	129
C1RXOVIFL (CAN Receive Overflow Interrupt Status Low).....	237	CNFx (Interrupt Change Notification Flag for PORTx).....	130
C1TBCH (CAN Time Base Counter High).....	230	CNPDx (Change Notification Pull-Down Enable for PORTx).....	127
C1TBCL (CAN Time Base Counter Low).....	230	CNPUx (Change Notification Pull-up Enable for PORTx).....	127
C1TDCH (CAN Transmitter Delay Compensation High).....	228	CNSTATx (Interrupt Change Notification Status for PORTx).....	129
C1TDCL (CAN Transmitter Delay Compensation Low).....	229	CORCON (Core Control).....	38, 114
C1TEFCONH (CAN Transmit Event FIFO Control High).....	250	CRCCONH (CRC Control High).....	485
C1TEFCONL (CAN Transmit Event FIFO Control Low).....	251	CRCCONL (CRC Control Low).....	484
C1TEFSTA (CAN Transmit Event FIFO Status).....	252	CRCXORH (CRC XOR Polynomial, High Byte).....	486
C1TEFUAH (CAN Transmit Event FIFO User Address High).....	254	CRCXORL (CRC XOR Polynomial, Low Byte).....	486
C1TEFUAL (CAN Transmit Event FIFO User Address Low).....	254	CTXTSTAT (CPU W Register Context Status).....	40
C1TRECH (CAN Transmit/Receive Error Count High).....	256	DACCTRL1L (DAC Control 1 Low).....	334
C1TRECL (CAN Transmit/Receive Error Count Low).....	256	DACCTRL2H (DAC Control 2 High).....	335
C1TSCONH (CAN Timestamp Control High).....	231	DACCTRL2L (DAC Control 2 Low).....	335
C1TSCONL (CAN Timestamp Control Low).....	231	DACxCONH (DACx Control High).....	336
C1TXATIFH (CAN Transmit Attempt Interrupt Status High).....	239	DACxCONL (DACx Control Low).....	336
C1TXATIFL (CAN Transmit Attempt Interrupt Status Low).....	239	DACxDATH (DACx Data High).....	338
C1TXIFH (CAN Transmit Interrupt Status High).....	238	DACxDATL (DACx Data Low).....	338
C1TXIFL (CAN Transmit Interrupt Status Low).....	238	DEVID (Device ID).....	532
C1TXQCONH (CAN Transmit Queue Control High).....	242	DEVREV (Device Revision).....	532
		DMACHn (DMA Channel n Control).....	217
		DMACON (DMA Engine Control).....	216
		DMAINTn (DMA Channel n Interrupt).....	218
		DMTCLR (Deadman Timer Clear).....	497
		DMTCNTH (Deadman Timer Count High).....	499
		DMTCNTL (Deadman Timer Count Low).....	499
		DMTCON (Deadman Timer Control).....	496
		DMTHOLDREG (DMT Hold).....	502
		DMPRECLR (Deadman Timer Preclear).....	496

# dsPIC33CK256MP508 FAMILY

DMTPSCNTH (DMT Post-Configure Count Status High) .....	500	MSTRPR (EDS Bus Initiator Priority Control) .....	39
DMTPSCNTL (DMT Post-Configure Count Status Low) .....	500	NVMADR (Nonvolatile Memory Lower Address) .....	91
DMTPSINTVH (DMT Post-Configure Interval Status High) .....	501	NVMADRU (Nonvolatile Memory Upper Address) .....	91
DMTPSINTVL (DMT Post-Configure Interval Status Low) .....	501	NVMCON (Nonvolatile Memory (NVM) Control) .....	89
DMTSTAT (Deadman Timer Status) .....	498	NVMKEY (Nonvolatile Memory Key) .....	92
ECCADDRH (ECC Fault Inject Address Compare High) .....	95	NVMSRCADRH (NVM Source Data Address High) ...	93
ECCADDRL (ECC Fault Inject Address Compare Low) .....	95	NVMSRCADRL (NVM Source Data Address Low) ....	93
ECCCONH (ECC Fault Injection Configuration High) .....	94	ODCx (Open-Drain Enable for PORTx) .....	126
ECCCONL (ECC Fault Injection Configuration Low) .....	94	OSCCON (Oscillator Control) .....	196
ECCSTATH (ECC System Status Display High) .....	96	OSCTUN (FRC Oscillator Tuning) .....	201
ECCSTATL (ECC System Status Display Low) .....	96	PCLKCON (PWM Clock Control) .....	268
FALTREG Configuration .....	529	PGxCAP (PWM Generator x Capture) .....	299
FBOOT Configuration .....	531	PGxCONH (PWM Generator x Control High) .....	280
FBSLIM Configuration .....	519	PGxCONL (PWM Generator x Control Low) .....	279
FBTSEQ Configuration .....	530	PGxDC (PWM Generator x Duty Cycle) .....	295
FDEVOPT Configuration .....	528	PGxDCA (PWM Generator x Duty Cycle Adjustment) .....	296
FDMT Configuration .....	527	PGxDTH (PWM Generator x Dead-Time High) .....	298
FDMTCNTH Configuration .....	526	PGxDTL (PWM Generator x Dead-Time Low) .....	298
FDMTCNTL Configuration .....	526	PGxEVTH (PWM Generator x Event High) .....	287
FDMTIVTH Configuration .....	525	PGxEVTL (PWM Generator x Event Low) .....	286
FDMTIVTL Configuration .....	525	PGxIOCONH (PWM Generator x I/O Control High) .....	285
FICD Configuration .....	524	PGxIOCONL (PWM Generator x I/O Control Low) .....	284
FOSC Configuration .....	521	PGxLEBH (PWM Generator x Leading-Edge Blanking High) .....	294
FOSSEL Configuration .....	520	PGxLEBL (PWM Generator x Leading-Edge Blanking Low) .....	293
FPOR Configuration .....	523	PGxPER (PWM Generator x Period) .....	296
FSCL (Frequency Scale) .....	269	PGxPHASE (PWM Generator x Phase) .....	295
FSEC Configuration .....	518	PGxSTAT (PWM Generator x Status) .....	282
FSIGN Configuration .....	519	PGxTRIGA (PWM Generator x Trigger A) .....	297
FSMINPER (Frequency Scaling Minimum Period) ...	269	PGxTRIGB (PWM Generator x Trigger B) .....	297
FWDT Configuration .....	522	PGxTRIGC (PWM Generator x Trigger C) .....	297
I2CxCONH (I2Cx Control High) .....	409	PGxyPCIH (PWM Generator xy PCI High) .....	291
I2CxCONL (I2Cx Control Low) .....	407	PGxyPCLL (PWM Generator xy PCI Low) .....	289
I2CxMSK (I2Cx Client Mode Address Mask) .....	411	PLLDIV (PLL Output Divider) .....	202
I2CxSTAT (I2Cx Status) .....	410	PLLFB (PLL Feedback Divider) .....	200
IBIASCONH (Current Bias Generator Current Source Control High) .....	489	PMADDR (PMP Address) .....	419
IBIASCONL (Current Bias Generator Current Source Control Low) .....	490	PMAEN (PMP Pin Enable) .....	422
INDXxCNTH (Index x Counter High) .....	358	PMCON (PMP Control) .....	414
INDXxCNTL (Index x Counter Low) .....	358	PMCONH (PMP Control High) .....	416
INDXxHLD (Index x Counter Hold) .....	359	PMD1 (PMD1 Control) .....	506
INTCON1 (Interrupt Control 1) .....	115	PMD2 (PMD2 Control) .....	507
INTCON2 (Interrupt Control 2) .....	117	PMD3 (PMD3 Control) .....	508
INTCON3 (Interrupt Control 3) .....	118	PMD4 (PMD4 Control) .....	509
INTCON4 (Interrupt Control 4) .....	119	PMD6 (PMD6 Control) .....	510
INTTREG (Interrupt Control and Status) .....	120	PMD7 (PMD7 Control) .....	511
INTxTMRH (Interval x Timer High) .....	356	PMD8 (PMD8 Control) .....	512
INTxTMRL (Interval x Timer Low) .....	356	PMDIN1 (PMP Data Input/Output Low) .....	421
INTxHLDH (Interval x Timer Hold High) .....	357	PMDIN2 (PMP Data Input/Output High) .....	421
INTxHLDL (Interval x Timer Hold Low) .....	357	PMDOUT1 (PMP Data Output Low) .....	420
LATx (Output Data for PORTx) .....	126	PMDOUT2 (PMP Data Output High) .....	420
LFSR (Linear Feedback Shift) .....	278	PMODE (PMP Mode) .....	417
LOGCONy (Combinatorial PWM Logic Control y) ....	274	PMRADDR (PMP Read Address) .....	425
MBISTCON (MBIST Control) .....	53	PMRDIN (PMP Read Input Data) .....	426
MDC (Master Duty Cycle) .....	270	PMSTAT (PMP Status) .....	423
MPER (Master Period) .....	271	PMWADDR (PMP Write Address) .....	424
MPHASE (Master Phase) .....	270	PORTx (Input Data for PORTx) .....	125
		POSxCNTH (Position x Counter High) .....	352
		POSxCNTL (Position x Counter Low) .....	352
		POSxHLD (Position x Counter Hold) .....	353
		PTGADJ (PTG Adjust) .....	476
		PTGBTE (PTG Broadcast Trigger Enable Low) .....	472

# dsPIC33CK256MP508 FAMILY

PTGBTEH (PTG Broadcast Trigger Enable High).....	472	RPINR49 (Peripheral Pin Select Input 49) .....	168
PTGC0LIM (PTG Counter 0 Limit).....	475	RPINR5 (Peripheral Pin Select Input 5) .....	151
PTGC1LIM (PTG Counter 1 Limit).....	475	RPINR6 (Peripheral Pin Select Input 6) .....	151
PTGCON (PTG Control/Status High).....	471	RPINR7 (Peripheral Pin Select Input 7) .....	152
PTGCST (PTG Control/Status Low) .....	469	RPINR8 (Peripheral Pin Select Input 8) .....	152
PTGHOLD (PTG Hold) .....	473	RPINR9 (Peripheral Pin Select Input 9) .....	153
PTGL0 (PTG Literal 0) .....	476	RPOR0 (Peripheral Pin Select Output 0) .....	169
PTGQPTR (PTG Step Queue Pointer) .....	477	RPOR1 (Peripheral Pin Select Output 1) .....	169
PTGQUE n (PTG Step Queue n Pointer) .....	477	RPOR10 (Peripheral Pin Select Output 10) .....	174
PTGSDLIM (PTG Step Delay Limit).....	474	RPOR11 (Peripheral Pin Select Output 11) .....	174
PTGT0LIM (PTG Timer0 Limit).....	473	RPOR12 (Peripheral Pin Select Output 12) .....	175
PTGT1LIM (PTG Timer1 Limit).....	474	RPOR13 (Peripheral Pin Select Output 13) .....	175
PWMEV Ty (PWM Event Output Control y).....	276	RPOR14 (Peripheral Pin Select Output 14) .....	176
QEIXCON (QEIX Control).....	346	RPOR15 (Peripheral Pin Select Output 15) .....	176
QEIXGECH (QEIX Greater Than or Equal Compare High) .....	362	RPOR16 (Peripheral Pin Select Output 16) .....	177
QEIXGECL (QEIX Greater Than or Equal Compare Low) .....	362	RPOR17 (Peripheral Pin Select Output 17) .....	177
QEIXICH (QEIX Initialization/Capture High) .....	360	RPOR18 (Peripheral Pin Select Output 18) .....	178
QEIXICL (QEIX Initialization/Capture Low).....	360	RPOR19 (Peripheral Pin Select Output 19) .....	178
QEIXIOC (QEIX I/O Control).....	348	RPOR2 (Peripheral Pin Select Output 2) .....	170
QEIXIOCH (QEIX I/O Control High).....	349	RPOR20 (Peripheral Pin Select Output 20) .....	179
QEIXLECH (QEIX Less Than or Equal Compare High) .....	361	RPOR21 (Peripheral Pin Select Output 21) .....	179
QEIXLECL (QEIX Less Than or Equal Compare Low) .....	361	RPOR22 (Peripheral Pin Select Output 22) .....	180
QEIXSTAT (QEIX Status).....	350	RPOR23 (Peripheral Pin Select Output 23) .....	180
RCON (Reset Control).....	99	RPOR24 (Peripheral Pin Select Output 24) .....	181
REFOCONH (Reference Clock Control High) .....	208	RPOR25 (Peripheral Pin Select Output 25) .....	181
REFOCONL (Reference Clock Control Low).....	207	RPOR26 (Peripheral Pin Select Output 26) .....	182
REFOTRIMH (Reference Oscillator Trim) .....	209	RPOR3 (Peripheral Pin Select Output 3) .....	170
RPCON (Peripheral Remapping Configuration) .....	148	RPOR4 (Peripheral Pin Select Output 4) .....	171
RPINR0 (Peripheral Pin Select Input 0).....	148	RPOR5 (Peripheral Pin Select Output 5) .....	171
RPINR1 (Peripheral Pin Select Input 1).....	149	RPOR6 (Peripheral Pin Select Output 6) .....	172
RPINR10 (Peripheral Pin Select Input 10).....	153	RPOR7 (Peripheral Pin Select Output 7) .....	172
RPINR11 (Peripheral Pin Select Input 11).....	154	RPOR8 (Peripheral Pin Select Output 8) .....	173
RPINR12 (Peripheral Pin Select Input 12).....	154	RPOR9 (Peripheral Pin Select Output 9) .....	173
RPINR13 (Peripheral Pin Select Input 13).....	155	SENTxCON1 (SENTx Control 1).....	431
RPINR14 (Peripheral Pin Select Input 14).....	155	SENTxDATH (SENTx Receive Data High).....	435
RPINR15 (Peripheral Pin Select Input 15).....	156	SENTxDATL (SENTx Receive Data Low).....	435
RPINR16 (Peripheral Pin Select Input 16).....	156	SENTxSTAT (SENTx Status).....	433
RPINR17 (Peripheral Pin Select Input 17).....	157	SLPxCONH (DACx Slope Control High) .....	339
RPINR18 (Peripheral Pin Select Input 18).....	157	SLPxCONL (DACx Slope Control Low).....	340
RPINR19 (Peripheral Pin Select Input 19).....	158	SLPxDAT (DACx Slope Data) .....	342
RPINR2 (Peripheral Pin Select Input 2).....	149	SPIxCON1H (SPIx Control 1 High) .....	392
RPINR20 (Peripheral Pin Select Input 20).....	158	SPIxCON1L (SPIx Control 1 Low).....	390
RPINR21 (Peripheral Pin Select Input 21).....	159	SPIxCON2L (SPIx Control 2 Low).....	394
RPINR22 (Peripheral Pin Select Input 22).....	159	SPIxIMSKH (SPIx Interrupt Mask High) .....	399
RPINR23 (Peripheral Pin Select Input 23).....	160	SPIxIMSKL (SPIx Interrupt Mask Low).....	398
RPINR26 (Peripheral Pin Select Input 26).....	160	SPIxSTATH (SPIx Status High).....	397
RPINR27 (Peripheral Pin Select Input 27).....	161	SPIxSTATL (SPIx Status Low).....	395
RPINR29 (Peripheral Pin Select Input 29).....	161	SR (CPU STATUS) .....	36, 113
RPINR3 (Peripheral Pin Select Input 3).....	150	T1CON (Timer1 Control) .....	438
RPINR30 (Peripheral Pin Select Input 30).....	162	TRISx (Output Enable for PORTx) .....	125
RPINR32 (Peripheral Pin Select Input 32).....	162	UxBRG (UARTx Baud Rate) .....	374
RPINR33 (Peripheral Pin Select Input 33).....	163	UxBRGH (UARTx Baud Rate High) .....	374
RPINR37 (Peripheral Pin Select Input 37).....	163	UxINT (UARTx Interrupt).....	383
RPINR38 (Peripheral Pin Select Input 38).....	164	UxMODE (UARTx Configuration).....	366
RPINR4 (Peripheral Pin Select Input 4).....	150	UxMODEH (UARTx Configuration High).....	368
RPINR42 (Peripheral Pin Select Input 42).....	164	UxP1 (UARTx Timing Parameter 1) .....	376
RPINR43 (Peripheral Pin Select Input 43).....	165	UxP2 (UARTx Timing Parameter 2) .....	377
RPINR44 (Peripheral Pin Select Input 44).....	165	UxP3 (UARTx Timing Parameter 3) .....	378
RPINR45 (Peripheral Pin Select Input 45).....	166	UxP3H (UARTx Timing Parameter 3 High) .....	378
RPINR46 (Peripheral Pin Select Input 46).....	166	UxRXCHK (UARTx Receive Checksum).....	380
RPINR47 (Peripheral Pin Select Input 47).....	167	UxRXREG (UARTx Receive Buffer).....	375
RPINR48 (Peripheral Pin Select Input 48).....	167	UxSCCON (UARTx Smart Card Configuration) .....	381
		UxSCINT (UARTx Smart Card Interrupt).....	382
		UxSTA (UARTx Status).....	370
		UxSTAH (UARTx Status High).....	372
		UxTXCHK (UARTx Transmit Checksum).....	379

# dsPIC33CK256MP508 FAMILY

UxTXREG (UARTx Transmit Buffer).....	375
VELxCNT (Velocity x Counter) .....	354
VELxCNTH (Velocity x Counter High) .....	354
VELxHLD (Velocity x Counter Hold) .....	355
VREGCON (Voltage Regulator Control).....	535
WDTCNH (Watchdog Timer Control High).....	538
WDTCNL (Watchdog Timer Control Low).....	537
Resets .....	97
Brown-out Reset (BOR) .....	97
Configuration Mismatch Reset (CM).....	97
Illegal Condition Reset (IOPUWR).....	97
Illegal Opcode .....	97
Security .....	97
Uninitialized W Register.....	97
Master Clear (MCLR) Pin Reset .....	97
Power-on Reset (POR) .....	97
RESET Instruction (SWR).....	97
Resources .....	98
Trap Conflict Reset (TRAPR).....	97
Watchdog Timer Time-out Reset (WDTO).....	97
Revision History .....	629
<b>S</b>	
SENTx Protocol Data Frames.....	428
Serial Peripheral Interface (SPI) .....	385
Serial Peripheral Interface. <i>See</i> SPI.	
SFR Blocks	
000h .....	54
100h .....	55
200h .....	56
300h .....	57
400h .....	58
500h .....	59
600h .....	60
800h .....	61
900h .....	62
A00h.....	63
B00h.....	64
C00h .....	65
D00h .....	66
E00h.....	67
F00h.....	68
Single-Edge Nibble Transmission (SENT) .....	427
Control Registers .....	431
Receive Mode .....	430
Configuration.....	430
Transmit Mode .....	429
Configuration.....	429
Single-Edge Nibble Transmission for Automotive Applications.....	427
Single-Edge Nibble Transmission. <i>See</i> SENT.	
Special Features of the CPU.....	515
SPI	
Control Registers .....	390
<b>T</b>	
Terminology Cross Reference .....	17
Thermal Operating Conditions .....	554
Thermal Packaging Characteristics .....	554
Timer1.....	437
Control Register.....	438
Timing Diagrams	
BOR and Master Clear Reset Characteristics .....	569
Clock/Instruction Cycle .....	191
External Clock.....	566
High-Speed PWMx Fault Characteristics .....	571
High-Speed PWMx Module Characteristics.....	571
I/O Characteristics .....	569
I2Cx Bus Data (Client Mode).....	582
I2Cx Bus Data (Host Mode).....	580
I2Cx Bus Start/Stop Bits (Client Mode).....	582
I2Cx Bus Start/Stop Bits (Host Mode) .....	580
QE/QEB Input .....	585
QEI Interface Signals.....	343
QEI Module Index Pulse .....	586
SPIx Client Mode (Full-Duplex, CKE = 0, CKP = x, SMP = 0) .....	576
SPIx Client Mode (Full-Duplex, CKE = 1, CKP = x, SMP = 0) .....	578
SPIx Host Mode (Full-Duplex, CKE = 0, CKP = x, SMP = 1) .....	575
SPIx Host Mode (Full-Duplex, CKE = 1, CKP = x, SMP = 1) .....	574
SPIx Host Mode (Half-Duplex, Transmit Only, CKE = 0).....	572
SPIx Host Mode (Half-Duplex, Transmit Only, CKE = 1).....	573
UARTx I/O Characteristics.....	584
Timing Specifications	
QEI Index Pulse Requirements .....	586
Quadrature Decoder Requirements.....	585
<b>U</b>	
UART	
Architectural Overview.....	364
Character Frame.....	365
Control Registers .....	366
Data Buffers.....	365
Protocol Extensions .....	365
Unique Device Identifier (UDID) .....	47
Unique Device Identifier. <i>See</i> UDID.	
Universal Asynchronous Receiver Transmitter (UART) ...	363
Universal Asynchronous Receiver Transmitter. <i>See</i> UART.	
User OTP Memory.....	534
<b>V</b>	
Voltage Regulator (On-Chip) .....	534
<b>W</b>	
Watchdog Timer (WDT).....	515
WWW Address .....	641
WWW, On-Line Support .....	15



## THE MICROCHIP WEBSITE

Microchip provides online support via our WWW site at [www.microchip.com](http://www.microchip.com). This website is used as a means to make files and information easily available to customers. Accessible by using your favorite Internet browser, the website contains the following information:

- **Product Support** – Data sheets and errata, application notes and sample programs, design resources, user's guides and hardware support documents, latest software releases and archived software
- **General Technical Support** – Frequently Asked Questions (FAQ), technical support requests, online discussion groups, Microchip consultant program member listing
- **Business of Microchip** – Product selector and ordering guides, latest Microchip press releases, listing of seminars and events, listings of Microchip sales offices, distributors and factory representatives

## CUSTOMER CHANGE NOTIFICATION SERVICE

Microchip's customer notification service helps keep customers current on Microchip products. Subscribers will receive e-mail notification whenever there are changes, updates, revisions or errata related to a specified product family or development tool of interest.

To register, access the Microchip website at [www.microchip.com](http://www.microchip.com). Under "Support", click on "Customer Change Notification" and follow the registration instructions.

## CUSTOMER SUPPORT

Users of Microchip products can receive assistance through several channels:

- Distributor or Representative
- Local Sales Office
- Field Application Engineer (FAE)
- Technical Support

Customers should contact their distributor, representative or Field Application Engineer (FAE) for support. Local sales offices are also available to help customers. A listing of sales offices and locations is included in the back of this document.

**Technical support is available through the website at: <http://microchip.com/support>**

# dsPIC33CK256MP508

---

NOTES:

# dsPIC33CK256MP508 FAMILY

## PRODUCT IDENTIFICATION SYSTEM

To order or obtain information, e.g., on pricing or delivery, refer to the factory or the listed sales office.

dsPIC 33 CK 256 MP 508 T - I / PT - XXX		<b>Examples:</b>										
Microchip Trademark _____	_____	dsPIC33CK256MP508-I/PT: dsPIC33, Enhanced Performance, 256-Kbyte Program Memory, MC, SMPS, 80-Pin, Industrial Temperature, TQFP Package.										
Architecture _____	_____											
Flash Memory Family _____	_____											
Program Memory Size (Kbyte) _____	_____											
Product Group _____	_____											
Pin Count _____	_____											
Tape and Reel Flag (if applicable) _____	_____											
Temperature Range _____	_____											
Package _____	_____											
Pattern _____	_____											
<table border="1" style="width: 100%; border-collapse: collapse;"> <tbody> <tr> <td style="padding: 5px;"><b>Architecture:</b></td> <td style="padding: 5px;">33 = 16-Bit Digital Signal Controller</td> </tr> <tr> <td style="padding: 5px;"><b>Product Group:</b></td> <td style="padding: 5px;">MP = Motor Control/Power Supply</td> </tr> <tr> <td style="padding: 5px;"><b>Pin Count:</b></td> <td style="padding: 5px;">02 = 28-pin 03 = 36-pin 05 = 48-pin 06 = 64-pin 08 = 80-pin</td> </tr> <tr> <td style="padding: 5px;"><b>Temperature Range:</b></td> <td style="padding: 5px;">I = -40°C to +85°C (Industrial) E = -40°C to +125°C (Extended) H = -40°C to +150°C (High)</td> </tr> <tr> <td style="padding: 5px;"><b>Package:</b></td> <td style="padding: 5px;">SS = Plastic Shrink Small Outline – (28-pin) 5.30 mm body (SSOP) 2N = Ultra Thin Plastic Quad Flat, No Lead – (28-pin) 6x6 mm body (UQFN) M5 = Ultra Thin Plastic Quad Flat, No Lead – (36-pin) 5x5 mm body (UQFN) PT = Thin Quad Flatpack – (48-pin) 7x7 mm body (TQFP) M4 = Ultra Thin Plastic Quad Flat, No Lead – (48-pin) 6x6 mm body (UQFN) PT = Plastic Thin Quad Flatpack – (64-pin) 10x10 mm body (TQFP) MR = Plastic Quad Flat, No Lead – (64-pin) 9x9 mm body (QFN) PT = Plastic Thin Quad Flatpack – (80-pin) 12x12 mm body (TQFP)</td> </tr> </tbody> </table>		<b>Architecture:</b>	33 = 16-Bit Digital Signal Controller	<b>Product Group:</b>	MP = Motor Control/Power Supply	<b>Pin Count:</b>	02 = 28-pin 03 = 36-pin 05 = 48-pin 06 = 64-pin 08 = 80-pin	<b>Temperature Range:</b>	I = -40°C to +85°C (Industrial) E = -40°C to +125°C (Extended) H = -40°C to +150°C (High)	<b>Package:</b>	SS = Plastic Shrink Small Outline – (28-pin) 5.30 mm body (SSOP) 2N = Ultra Thin Plastic Quad Flat, No Lead – (28-pin) 6x6 mm body (UQFN) M5 = Ultra Thin Plastic Quad Flat, No Lead – (36-pin) 5x5 mm body (UQFN) PT = Thin Quad Flatpack – (48-pin) 7x7 mm body (TQFP) M4 = Ultra Thin Plastic Quad Flat, No Lead – (48-pin) 6x6 mm body (UQFN) PT = Plastic Thin Quad Flatpack – (64-pin) 10x10 mm body (TQFP) MR = Plastic Quad Flat, No Lead – (64-pin) 9x9 mm body (QFN) PT = Plastic Thin Quad Flatpack – (80-pin) 12x12 mm body (TQFP)	
<b>Architecture:</b>	33 = 16-Bit Digital Signal Controller											
<b>Product Group:</b>	MP = Motor Control/Power Supply											
<b>Pin Count:</b>	02 = 28-pin 03 = 36-pin 05 = 48-pin 06 = 64-pin 08 = 80-pin											
<b>Temperature Range:</b>	I = -40°C to +85°C (Industrial) E = -40°C to +125°C (Extended) H = -40°C to +150°C (High)											
<b>Package:</b>	SS = Plastic Shrink Small Outline – (28-pin) 5.30 mm body (SSOP) 2N = Ultra Thin Plastic Quad Flat, No Lead – (28-pin) 6x6 mm body (UQFN) M5 = Ultra Thin Plastic Quad Flat, No Lead – (36-pin) 5x5 mm body (UQFN) PT = Thin Quad Flatpack – (48-pin) 7x7 mm body (TQFP) M4 = Ultra Thin Plastic Quad Flat, No Lead – (48-pin) 6x6 mm body (UQFN) PT = Plastic Thin Quad Flatpack – (64-pin) 10x10 mm body (TQFP) MR = Plastic Quad Flat, No Lead – (64-pin) 9x9 mm body (QFN) PT = Plastic Thin Quad Flatpack – (80-pin) 12x12 mm body (TQFP)											

# dsPIC33CK256MP508 FAMILY

---

NOTES:

---

**Note the following details of the code protection feature on Microchip products:**

- Microchip products meet the specifications contained in their particular Microchip Data Sheet.
- Microchip believes that its family of products is secure when used in the intended manner, within operating specifications, and under normal conditions.
- Microchip values and aggressively protects its intellectual property rights. Attempts to breach the code protection features of Microchip product is strictly prohibited and may violate the Digital Millennium Copyright Act.
- Neither Microchip nor any other semiconductor manufacturer can guarantee the security of its code. Code protection does not mean that we are guaranteeing the product is "unbreakable" Code protection is constantly evolving. Microchip is committed to continuously improving the code protection features of our products.

---

This publication and the information herein may be used only with Microchip products, including to design, test, and integrate Microchip products with your application. Use of this information in any other manner violates these terms. Information regarding device applications is provided only for your convenience and may be superseded by updates. It is your responsibility to ensure that your application meets with your specifications. Contact your local Microchip sales office for additional support or, obtain additional support at <https://www.microchip.com/en-us/support/design-help/client-support-services>.

THIS INFORMATION IS PROVIDED BY MICROCHIP "AS IS". MICROCHIP MAKES NO REPRESENTATIONS OR WARRANTIES OF ANY KIND WHETHER EXPRESS OR IMPLIED, WRITTEN OR ORAL, STATUTORY OR OTHERWISE, RELATED TO THE INFORMATION INCLUDING BUT NOT LIMITED TO ANY IMPLIED WARRANTIES OF NON-INFRINGEMENT, MERCHANTABILITY, AND FITNESS FOR A PARTICULAR PURPOSE, OR WARRANTIES RELATED TO ITS CONDITION, QUALITY, OR PERFORMANCE.

IN NO EVENT WILL MICROCHIP BE LIABLE FOR ANY INDIRECT, SPECIAL, PUNITIVE, INCIDENTAL, OR CONSEQUENTIAL LOSS, DAMAGE, COST, OR EXPENSE OF ANY KIND WHATSOEVER RELATED TO THE INFORMATION OR ITS USE, HOWEVER CAUSED, EVEN IF MICROCHIP HAS BEEN ADVISED OF THE POSSIBILITY OR THE DAMAGES ARE FORESEEABLE. TO THE FULLEST EXTENT ALLOWED BY LAW, MICROCHIP'S TOTAL LIABILITY ON ALL CLAIMS IN ANY WAY RELATED TO THE INFORMATION OR ITS USE WILL NOT EXCEED THE AMOUNT OF FEES, IF ANY, THAT YOU HAVE PAID DIRECTLY TO MICROCHIP FOR THE INFORMATION.

Use of Microchip devices in life support and/or safety applications is entirely at the buyer's risk, and the buyer agrees to defend, indemnify and hold harmless Microchip from any and all damages, claims, suits, or expenses resulting from such use. No licenses are conveyed, implicitly or otherwise, under any Microchip intellectual property rights unless otherwise stated.

For information regarding Microchip's Quality Management Systems, please visit [www.microchip.com/quality](http://www.microchip.com/quality).

**Trademarks**

The Microchip name and logo, the Microchip logo, Adaptec, AVR, AVR logo, AVR Freaks, BesTime, BitCloud, CryptoMemory, CryptoRF, dsPIC, flexPWR, HELDO, IGLoo, JukeBlox, KeeLoq, Klear, LANCheck, LinkMD, maXStylus, maXTouch, MediaLB, megaAVR, Microsemi, Microsemi logo, MOST, MOST logo, MPLAB, OptoLyzer, PIC, picoPower, PICSTART, PIC32 logo, PolarFire, Prochip Designer, QTouch, SAM-BA, SenGenuity, SpyNIC, SST, SST Logo, SuperFlash, Symmetricom, SyncServer, Tachyon, TimeSource, tinyAVR, UNI/O, Vectron, and XMEGA are registered trademarks of Microchip Technology Incorporated in the U.S.A. and other countries.

AgileSwitch, APT, ClockWorks, The Embedded Control Solutions Company, EtherSynch, Flashtec, Hyper Speed Control, HyperLight Load, Libero, motorBench, mTouch, Powermite 3, Precision Edge, ProASIC, ProASIC Plus, ProASIC Plus logo, Quiet-Wire, SmartFusion, SyncWorld, Temux, TimeCesium, TimeHub, TimePictra, TimeProvider, TrueTime, and ZL are registered trademarks of Microchip Technology Incorporated in the U.S.A.

Adjacent Key Suppression, AKS, Analog-for-the-Digital Age, Any Capacitor, AnyIn, AnyOut, Augmented Switching, BlueSky, BodyCom, Clockstudio, CodeGuard, CryptoAuthentication, CryptoAutomotive, CryptoCompanion, CryptoController, dsPICDEM, dsPICDEM.net, Dynamic Average Matching, DAM, ECAN, Espresso T1S, EtherGREEN, GridTime, IdealBridge, In-Circuit Serial Programming, ICSP, INICnet, Intelligent Paralleling, IntelliMOS, Inter-Chip Connectivity, JitterBlocker, Knob-on-Display, KoD, maxCrypto, maxView, memBrain, Mindi, MiWi, MPASM, MPF, MPLAB Certified logo, MPLIB, MPLINK, MultiTRAK, NetDetach, Omniscient Code Generation, PICDEM, PICDEM.net, PICkit, PICtail, PowerSmart, PureSilicon, QMatrix, REAL ICE, Ripple Blocker, RTAX, RTG4, SAM-ICE, Serial Quad I/O, simpleMAP, SimpliPHY, SmartBuffer, SmartHLS, SMART-I.S., storClad, SQI, SuperSwitcher, SuperSwitcher II, Switchtec, SynchroPHY, Total Endurance, Trusted Time, TSHARC, USBCheck, VariSense, VectorBlox, VeriPHY, ViewSpan, WiperLock, XpressConnect, and ZENA are trademarks of Microchip Technology Incorporated in the U.S.A. and other countries.

SQTP is a service mark of Microchip Technology Incorporated in the U.S.A.

The Adaptec logo, Frequency on Demand, Silicon Storage Technology, and Symmcom are registered trademarks of Microchip Technology Inc. in other countries.

GestIC is a registered trademark of Microchip Technology Germany II GmbH & Co. KG, a subsidiary of Microchip Technology Inc., in other countries.

All other trademarks mentioned herein are property of their respective companies.

© 2017-2022, Microchip Technology Incorporated and its subsidiaries.

All Rights Reserved.

ISBN: 978-1-6683-0662-8



# MICROCHIP

## Worldwide Sales and Service

### AMERICAS

**Corporate Office**  
2355 West Chandler Blvd.  
Chandler, AZ 85224-6199  
Tel: 480-792-7200  
Fax: 480-792-7277  
Technical Support:  
<http://www.microchip.com/support>  
Web Address:  
[www.microchip.com](http://www.microchip.com)

#### Atlanta

Duluth, GA  
Tel: 678-957-9614  
Fax: 678-957-1455

#### Austin, TX

Tel: 512-257-3370

#### Boston

Westborough, MA  
Tel: 774-760-0087  
Fax: 774-760-0088

#### Chicago

Itasca, IL  
Tel: 630-285-0071  
Fax: 630-285-0075

#### Dallas

Addison, TX  
Tel: 972-818-7423  
Fax: 972-818-2924

#### Detroit

Novi, MI  
Tel: 248-848-4000

#### Houston, TX

Tel: 281-894-5983

#### Indianapolis

Noblesville, IN  
Tel: 317-773-8323  
Fax: 317-773-5453  
Tel: 317-536-2380

#### Los Angeles

Mission Viejo, CA  
Tel: 949-462-9523  
Fax: 949-462-9608  
Tel: 951-273-7800

#### Raleigh, NC

Tel: 919-844-7510

#### New York, NY

Tel: 631-435-6000

#### San Jose, CA

Tel: 408-735-9110  
Tel: 408-436-4270

#### Canada - Toronto

Tel: 905-695-1980  
Fax: 905-695-2078

### ASIA/PACIFIC

**Australia - Sydney**  
Tel: 61-2-9868-6733

**China - Beijing**  
Tel: 86-10-8569-7000

**China - Chengdu**  
Tel: 86-28-8665-5511

**China - Chongqing**  
Tel: 86-23-8980-9588

**China - Dongguan**  
Tel: 86-769-8702-9880

**China - Guangzhou**  
Tel: 86-20-8755-8029

**China - Hangzhou**  
Tel: 86-571-8792-8115

**China - Hong Kong SAR**  
Tel: 852-2943-5100

**China - Nanjing**  
Tel: 86-25-8473-2460

**China - Qingdao**  
Tel: 86-532-8502-7355

**China - Shanghai**  
Tel: 86-21-3326-8000

**China - Shenyang**  
Tel: 86-24-2334-2829

**China - Shenzhen**  
Tel: 86-755-8864-2200

**China - Suzhou**  
Tel: 86-186-6233-1526

**China - Wuhan**  
Tel: 86-27-5980-5300

**China - Xian**  
Tel: 86-29-8833-7252

**China - Xiamen**  
Tel: 86-592-2388138

**China - Zhuhai**  
Tel: 86-756-3210040

### ASIA/PACIFIC

**India - Bangalore**  
Tel: 91-80-3090-4444

**India - New Delhi**  
Tel: 91-11-4160-8631

**India - Pune**  
Tel: 91-20-4121-0141

**Japan - Osaka**  
Tel: 81-6-6152-7160

**Japan - Tokyo**  
Tel: 81-3-6880-3770

**Korea - Daegu**  
Tel: 82-53-744-4301

**Korea - Seoul**  
Tel: 82-2-554-7200

**Malaysia - Kuala Lumpur**  
Tel: 60-3-7651-7906

**Malaysia - Penang**  
Tel: 60-4-227-8870

**Philippines - Manila**  
Tel: 63-2-634-9065

**Singapore**  
Tel: 65-6334-8870

**Taiwan - Hsin Chu**  
Tel: 886-3-577-8366

**Taiwan - Kaohsiung**  
Tel: 886-7-213-7830

**Taiwan - Taipei**  
Tel: 886-2-2508-8600

**Thailand - Bangkok**  
Tel: 66-2-694-1351

**Vietnam - Ho Chi Minh**  
Tel: 84-28-5448-2100

### EUROPE

**Austria - Wels**  
Tel: 43-7242-2244-39  
Fax: 43-7242-2244-393

**Denmark - Copenhagen**  
Tel: 45-4485-5910  
Fax: 45-4485-2829

**Finland - Espoo**  
Tel: 358-9-4520-820

**France - Paris**  
Tel: 33-1-69-53-63-20  
Fax: 33-1-69-30-90-79

**Germany - Garching**  
Tel: 49-8931-9700

**Germany - Haan**  
Tel: 49-2129-3766400

**Germany - Heilbronn**  
Tel: 49-7131-72400

**Germany - Karlsruhe**  
Tel: 49-721-625370

**Germany - Munich**  
Tel: 49-89-627-144-0  
Fax: 49-89-627-144-44

**Germany - Rosenheim**  
Tel: 49-8031-354-560

**Israel - Ra'anana**  
Tel: 972-9-744-7705

**Italy - Milan**  
Tel: 39-0331-742611  
Fax: 39-0331-466781

**Italy - Padova**  
Tel: 39-049-7625286

**Netherlands - Drunen**  
Tel: 31-416-690399  
Fax: 31-416-690340

**Norway - Trondheim**  
Tel: 47-7288-4388

**Poland - Warsaw**  
Tel: 48-22-3325737

**Romania - Bucharest**  
Tel: 40-21-407-87-50

**Spain - Madrid**  
Tel: 34-91-708-08-90  
Fax: 34-91-708-08-91

**Sweden - Gothenberg**  
Tel: 46-31-704-60-40

**Sweden - Stockholm**  
Tel: 46-8-5090-4654

**UK - Wokingham**  
Tel: 44-118-921-5800  
Fax: 44-118-921-5820

## X-ON Electronics

Largest Supplier of Electrical and Electronic Components

*Click to view similar products for Digital Signal Processors & Controllers - DSP, DSC category:*

*Click to view products by Microchip manufacturer:*

Other Similar products are found below :

[646890G](#) [0W888-002-XTP](#) [B4860NXE7QUMD](#) [ISL68221IRAZ](#) [TMX320C6748ZWT](#) [dsPIC33EP16GS502-EMM](#) [DSPIC33EP512MC504-EML](#) [dsPIC33EV256GM002-ESO](#) [ADSP-BF700BCPZ-2](#) [ADSP-BF705BBCZ-4](#) [ADSP-2187NBSTZ-320](#) [TMS320DM6433ZDU7](#) [TMS320VC5506ZHH](#) [MC56F8245VLD](#) [DSPIC33FJ64GP310A-I/PF](#) [DSPIC33FJ32MC204-H/PT](#) [DSPIC33FJ32MC102-I/TL](#) [DSPIC33FJ32GP102-I/TL](#) [DSPIC33FJ32GP102-I/ML](#) [DSPIC33FJ256MC510-I/PF](#) [DSPIC33FJ256GP710T-I/PF](#) [DSPIC33FJ256GP510A-I/PT](#) [DSPIC33FJ06GS102-I/SP](#) [DSPIC33EP512MU810-I/BG](#) [DSPIC33EP32MC502-I/SP](#) [DSPIC33EP32GS202-I/M6](#) [DSPIC33EP16GS506-I/PT](#) [DSPIC33EP16GS202-I/M6](#) [DSPIC30F2011T-20E/SO](#) [DSPIC30F2011-30I/ML](#) [DSPIC33FJ64GS610-50I/PT](#) [DSPIC33FJ64GS610-50I/PF](#) [DSPIC33FJ64GS606-50I/PT](#) [DSPIC33FJ32MC202-I/SP](#) [DSPIC33FJ32MC102-I/SP](#) [DSPIC33FJ32GS610-I/PT](#) [DSPIC33FJ32GS610-50I/PT](#) [DSPIC33FJ32GP202-E/MM](#) [DSPIC33FJ256MC710-I/PF](#) [DSPIC33FJ256GP710A-I/PF](#) [DSPIC33FJ256GP510A-I/PF](#) [DSPIC33FJ128GP802-I/MM](#) [DSPIC33EV32GM006-I/PT](#) [DSPIC33EP16GS504-I/PT](#) [DSPIC30F4013-20I/ML](#) [DSPIC30F2012-30I/ML](#) [DSPIC30F1010-20E/MM](#) [TMX320C6748ZCE](#) [TMS320C5532AZHHA10](#) [DSPIC33FJ64GP202-E/SP](#)