

PIC32CM JH01 Curiosity Nano+ Touch Evaluation Kit

User's Guide

EV29G58A/5



Preface

The PIC32CM JH01 Curiosity Nano+ Touch Evaluation Kit (EV29G58A/5) is a hardware platform which uses the PIC32CM5164JH01048 microcontroller. The evaluation kit provides an easy access to the microcontroller features and can be used to develop custom applications.

The PIC32CM JH01 Curiosity Nano+ Touch Evaluation Kit is pre-programmed with a stand-alone demonstration application, and it uses power provided by its micro-USB connection. The evaluation kit can be used as a stand-alone discovery element; however, it can be combined with expansion elements for quick prototyping. The PIC32CM JH01 Curiosity Nano+ Touch Evaluation Kit is shown below:

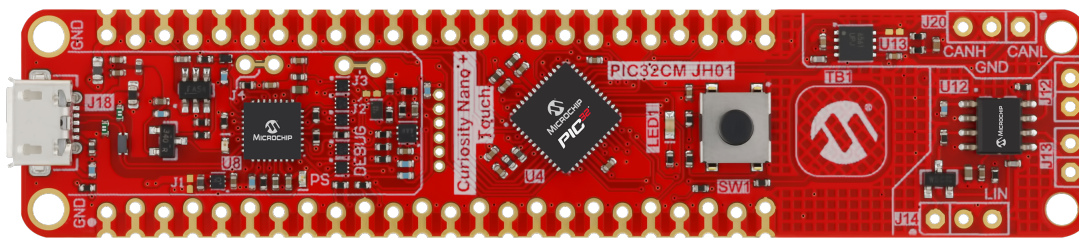

Each PIC32CM JH01 Curiosity Nano+ Touch Evaluation Kit is compatible with the Curiosity Nano base for Click boards™, AC164162. The base for Click boards includes a Curiosity Nano+ Touch socket, three mikroBUS™ sockets, and an Xplained Pro socket. The Curiosity Nano+ Touch board base for Click boards and interface boards enable developers to effortlessly expand their designs with sensors, connectivity modules, and so on. The PIC32CM JH01 Curiosity Nano+ Touch Ecosystem is shown below:

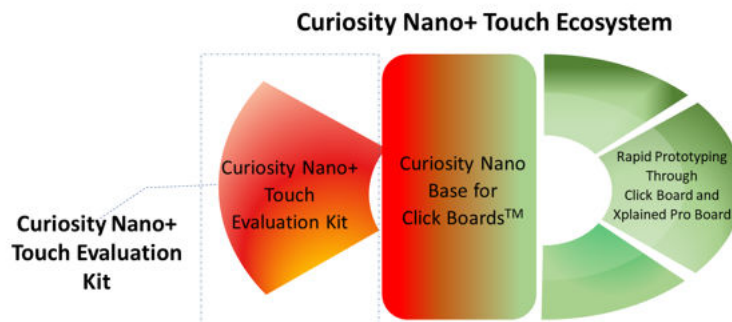

The evaluation kit is supported by the MPLAB® X Integrated Development Environment (IDE). The board provides an easy access to the features of the PIC32CM JH01 microcontroller to integrate the device into a custom design. The Curiosity Nano+ Touch series of evaluation kits include an on-board Nano Debugger, hence external tools are not required to program the PIC32CM JH01 device.

Table of Contents

Preface.....	1
1. Introduction.....	3
1.1. Processor Overview.....	3
1.2. Kit Overview.....	3
1.3. Features.....	3
2. Getting Started	5
2.1. PIC32CM JH01 Curiosity Nano+ Touch Quick Start	5
3. Curiosity Nano+ Touch.....	6
3.1. On-board Debugger.....	6
3.2. Curiosity Nano+ Touch Standard Pinout	8
3.3. Power Supply	8
3.4. Disconnecting the On-Board Debugger	10
3.5. Current Measurement	11
4. Hardware.....	12
4.1. Connectors.....	12
4.2. Peripherals	13
4.3. On-Board Debugger Implementation	14
5. Hardware Revision History	16
5.1. Identifying Product ID and Revision.....	16
6. Schematics.....	17
7. Revision History.....	22
Microchip Information.....	23
The Microchip Website.....	23
Product Change Notification Service.....	23
Customer Support.....	23
Microchip Devices Code Protection Feature.....	23
Legal Notice.....	23
Trademarks.....	24
Quality Management System.....	25
Worldwide Sales and Service.....	26

1. Introduction

The following sections provide the details of the PIC32CM JH01 Curiosity Nano+ Touch Evaluation Kit.

1.1 Processor Overview

This evaluation kit uses the PIC32CM5164JH01048 microcontroller units (MCUs) and its key features are as follows:

- For performance
 - Arm® Cortex®-M0+ CPU
 - picoPower® Technology and sleep modes
- For security
 - Integrity Check Module (ICM) to monitor memories based on Secure Hash Algorithm (SHA1, SHA224, SHA256), DMA assisted
 - Immutable Secure Boot
 - Clock failure detection
 - ECC support with fault injection for Flash, Data Flash, and SRAM
 - CRC32 computation on SRAM, Flash, and Data Flash sections through the Device Service Unit (DSU)
- For touch input
 - Peripheral Touch Controller (PTC)
 - Driven shield and parallel acquisition/boost mode for superior water tolerance
 - Excellent noise immunity and four times faster response time

1.2 Kit Overview

The PIC32CM JH01 Curiosity Nano+ Touch Evaluation Kit is a hardware platform to evaluate the PIC32CM5164JH01048 MCU.

Figure 1-1. PIC32CM JH01 Curiosity Nano+ Touch Evaluation Kit

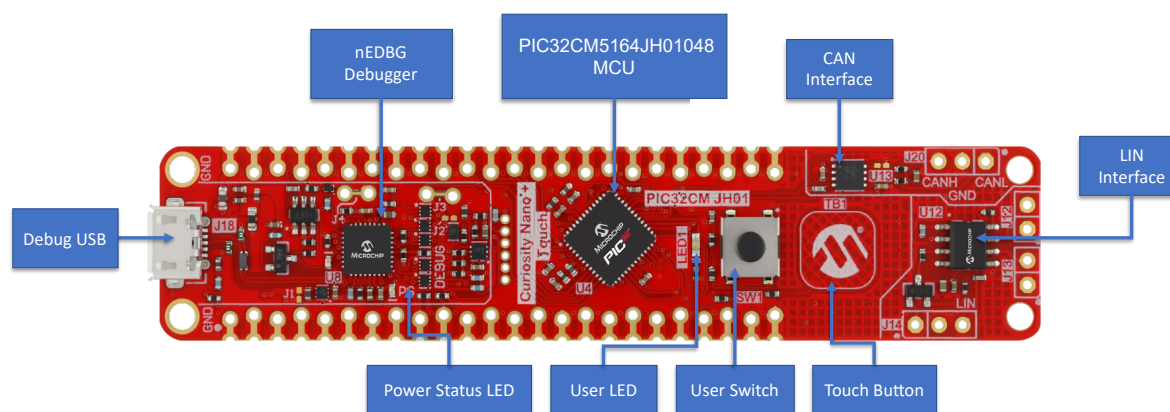

1.3 Features

The following are key features of the PIC32CM JH01 Curiosity Nano+ Touch Evaluation Kit:

- PIC32CM5164JH01048 microcontroller
- One yellow user LED

- One mechanical user switch
- One user touch button
- CAN interface
- LIN interface
- USB for debugger
 - Can be used for powering the board
 - Must be used to program or debug the board
- On-board nano debugger (nEDBG)
 - Board identification in MPLAB X IDE
 - One green power or status LED
 - Programing and debugging
 - Communications Device Class (CDC) virtual COM port
 - One logic analyzer DGI GPIO
 - The target device is programmed and debugged by the on-board Nano+ debugger, hence no external programmer or debugging tool is required
- Adjustable target voltage
 - MIC5353 LDO regulator controlled by the on-board debugger
 - 1.7V to 3.6V output voltage
 - 500 mA maximum output current (limited by ambient temperature and output voltage)

2. Getting Started

2.1 PIC32CM JH01 Curiosity Nano+ Touch Quick Start

Follow these steps to explore the PIC32CM JH01 Curiosity Nano+ Touch platform:

1. Download MPLAB X IDE.
2. Launch MPLAB X IDE.
3. Connect a USB cable (Standard-A to Micro-B or Micro-AB) between the PC and the debug USB port.

When the evaluation kit is connected to the computer for the first time, the operating system will install a software driver, and the driver is included with MPLAB X IDE. The driver file supports both 32-bit and 64-bit versions of Microsoft® Windows® XP, Windows Vista®, Windows 7, Windows 8, and Windows 10.

3. Curiosity Nano+ Touch

The Curiosity Nano+ Touch is an evaluation platform that provides a set of small boards with access to most of the microcontroller's I/O. The platform consists of a series of low pin-count microcontroller (MCU) boards, which are integrated with MPLAB X IDE to present relevant user's guides, application notes, data sheets, and example codes. The platform features a virtual COM port (CDC) for serial communication to a Host PC, and a Data Gateway Interface (DGI) GPIO.

3.1 On-board Debugger

The on-board debugger is a USB-enabled device with a debug application, a data gateway, and a virtual COM port.

Together with MPLAB X IDE, the on-board debugger interface can program and debug PIC32CM JH01 target.

A DGI is available to use with the logic analyzer channels for code instrumentation and to visualize program flow. DGI GPIOs can be graphed using the Data Visualizer.

The virtual COM port is connected to a UART peripheral on the target processor. The virtual COM port provides an easy way to communicate with the target application through terminal software.

The on-board debugger controls one power or status LED (marked PS). The following table provides how the LED is controlled in different operational modes.

Table 3-1. On-Board Debugger LED Control

Operation Mode	Status LED
Bootloader	LED blink at 1 Hz during power-up.
Power-up	LED is lit, constant.
Normal operation	LED is lit, constant.
Programming	Activity indicator, the LED flashes slowly during programming or debugging.
Fault	The LED flashes fast if a power fault is detected.
Sleep/Off	LED is OFF. The on-board debugger is either in Sleep mode or Power-Down mode. This will occur only if the evaluation kit is externally powered.

3.1.1 Virtual COM Port

A general-purpose USB serial bridge between a Host PC and a target device.

3.1.1.1 Overview

The debugger implements a complex USB device that includes a standard Communications Device Class (CDC) interface, which appears on the Host as a virtual COM port.

CDC can be used to stream arbitrary data in both directions between the Host and the target. Characters sent from the Host will appear in the UART form on the CDC TX pin, and UART characters sent into the CDC RX pin will be sent back to the Host.

On Windows machines, the CDC will enumerate as the Curiosity virtual COM port and appear in the ports section of the device manager. The COM port number is usually displayed.

Notes:

- On the older version of Windows, a USB driver is required for CDC. This driver is included in the MPLAB X IDE installations.
- On Linux machines, the CDC will enumerate and appear as `/dev/ttyACM#`.
- On Mac machines, the CDC will enumerate and appear as `/dev/tty.usbmodem#`.

Depending on which terminal program is used, it will appear in the available list of modems as `usbmodem#`.

3.1.1.2 Limitations

Not all UART features are implemented in the debugger CDC. The following constraints exist:

- Baud rate – Must be in the range of 1200 bps to 500 kbps. Values outside this range will be forced to compliance without warning. The baud rate can be changed on-the-fly.
- Character format – Only 8-bit characters are supported.
- Parity – It can be odd, even, or none.
- Hardware flow control – Not supported.
- Stop bits – One or two bits are supported.

3.1.1.3 Signaling

During USB enumeration, the Host OS will start both communication and data pipes of the CDC interface. At this point, it is possible to set and read baud rate and other UART parameters of the CDC, but data sending and receiving will not be enabled.

On the Host PC when a terminal connects, it must assert the DTR signal. This is a virtual control signal that is implemented on the USB interface but not in hardware on the debugger.

Asserting DTR from the Host will indicate to the debugger that a CDC session is active, and it will enable its level shifters (if available) and start the CDC data send and receive mechanisms.

Disserting the DTR signal will not disable the level shifters, but it will disable the receiver. Without a DTR signal, no further data will be streamed to the Host. Data packets that are queued by the debug processor for the target MCU will continue to be sent, but no further data will be accepted.

3.1.1.4 Advanced Use

When the CDC is in normal operation, the on-board debugger is a true UART bridge between the Host and the device. However, under certain use cases, the debugger can override the basic operating mode and use the CDC pins for other purposes.

Dropping a `.txt` extension text file into the debugger's mass storage drive can be used to send characters out of the CDC TX pin. The text file must start with the characters: `CMD:SEND_UART=`. The maximum message length is 50 characters, and all remaining data in the frame is ignored. The default baud rate used in this mode is 9600 bps, but if the CDC is already active or has been configured, the recently used baud rate still applies.

USB-Level Framing Considerations

Sending data from the Host to the CDC can be done byte-wise or in blocks. Blocks will be chunked into 64-byte USB frames. Each frame will be queued up for sending to the CDC TX pin.

The debugger buffers frames, not bytes, so sending a small amount of data per frame can be inefficient, particularly at low-baud rates. A maximum of 4 x 64-byte frames can be active at any time, the debugger will throttle the incoming frames accordingly. Sending full 64-byte data frames data is the most efficient.

When receiving data from the target, the debugger will queue data bound for the Host. When a 64-byte frame is filled, the data is sent to the USB queue for transmission. Incomplete frames are pushed to the USB queue at approximately 100 ms intervals, triggered by USB start-of-frame tokens. Up to 8 x 64-byte frames can be active at any time.

If the application software running on the Host fails to receive data fast enough, an overrun will occur. An overrun will cause the last-filled buffer frame to be recycled. A full frame of data will be lost because of an overrun. To prevent an overrun, the user must ensure that the CDC data pipe is being read continuously, or the incoming data rate must be reduced.

3.2 Curiosity Nano+ Touch Standard Pinout

Twelve edge connections on Curiosity Nano+ Touch have a standardized pinout. The program and debug pins have distinct functions depending on the target programming interface as shown in the following figure.

Figure 3-1. Curiosity Nano+ Touch Standard Pinout

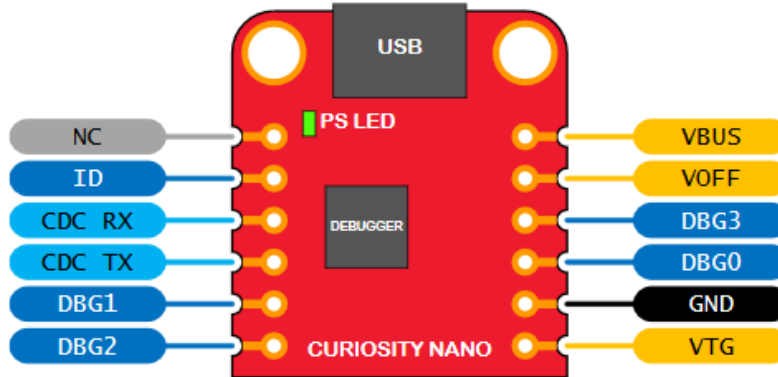

3.3 Power Supply

The kit is powered through the USB port and contains two regulators for generating 3.3V for the debugger, and an adjustable regulator for the target. The voltage from the USB connector can vary between 4.4V to 5.25V (according to the USB specification) and will limit the maximum voltage to the target.

The following figure illustrates the power supply system on the PIC32CM JH01 Curiosity Nano+ Touch Evaluation Kit.

Figure 3-2. Power Supply Block Diagram

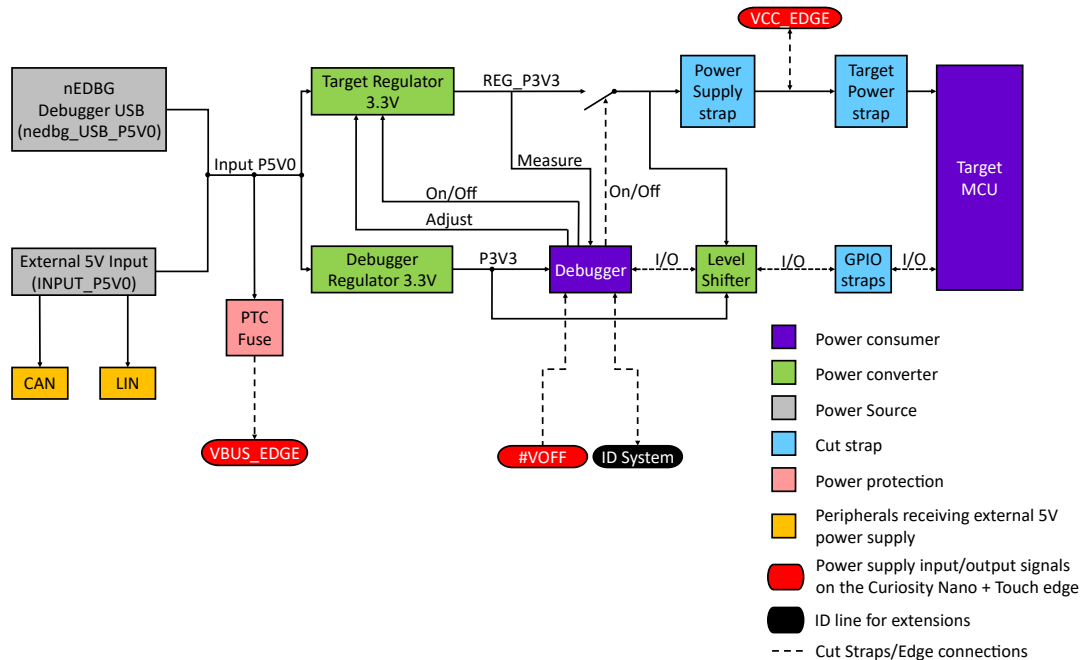

3.3.1 Target Voltage Regulator

The voltage regulator for the target processor is a MIC5353 variable output LDO. The on-board debugger can adjust the voltage output that is supplied to the target section by manipulating the LDO's feedback voltage.

The hardware implementation is limited to an approximate voltage range of 1.7V-5.1V. Additional output voltage limits are configured in the debugger firmware to ensure that the output voltage never exceeds the hardware limits of the MCU.

The voltage limits configured in the on-board debugger for the Curiosity Nano+ Touch are 1.7V-3.6V. The target voltage is set to 3.3V in production and can be changed using MPLAB X IDE. Any change to the target voltage will be persistent between power cycles. The MIC5353 supports a maximum current load of 500 mA. It is an LDO regulator in a small package, placed on a small PCB, and the thermal shutdown condition can be reached at lower loads than 500 mA. The maximum current load depends on the input voltage, output voltage set point, and ambient temperature.

The following figure shows the safe operational area for the regulator given an input voltage of 5.1V and an ambient temperature of 23°C.

Figure 3-3. Target Regulator Safe Operation Area

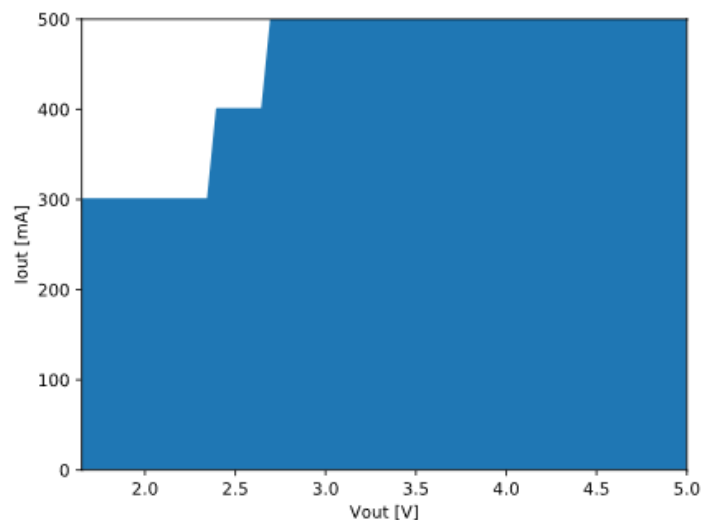

3.3.2 External Supply

The Curiosity Nano+ Touch can be powered by an external voltage instead of the on-board target regulator. When the voltage off (VOFF) pin is shorted to ground (GND), the on-board debugger firmware disables the target regulator, and it is safe to apply an external voltage to the VTG pin.



WARNING

Applying an external voltage to the VTG pin without shorting VOFF to GND may cause permanent damage.



WARNING

Absolute maximum external voltage is 5.5V for the level shifters on board. Applying a higher voltage may cause permanent damage.

Programming, debugging, and data streaming are still possible while using external power. The debugger and signal level shifters will be powered from the USB cable. Both regulators, the debugger, and the level shifters are powered down when the USB cable is removed.

3.4 Disconnecting the On-Board Debugger

The following block diagram illustrates the connection between the debugger and the PIC32CM JH01 microcontroller. The oval boxes represent connections to the board edge on the PIC32CM JH01 Curiosity Nano+ Touch. The signal names are shown in the following figure and printed in silkscreen on the bottom side of the board.

Figure 3-4. On-Board Debugger Connections

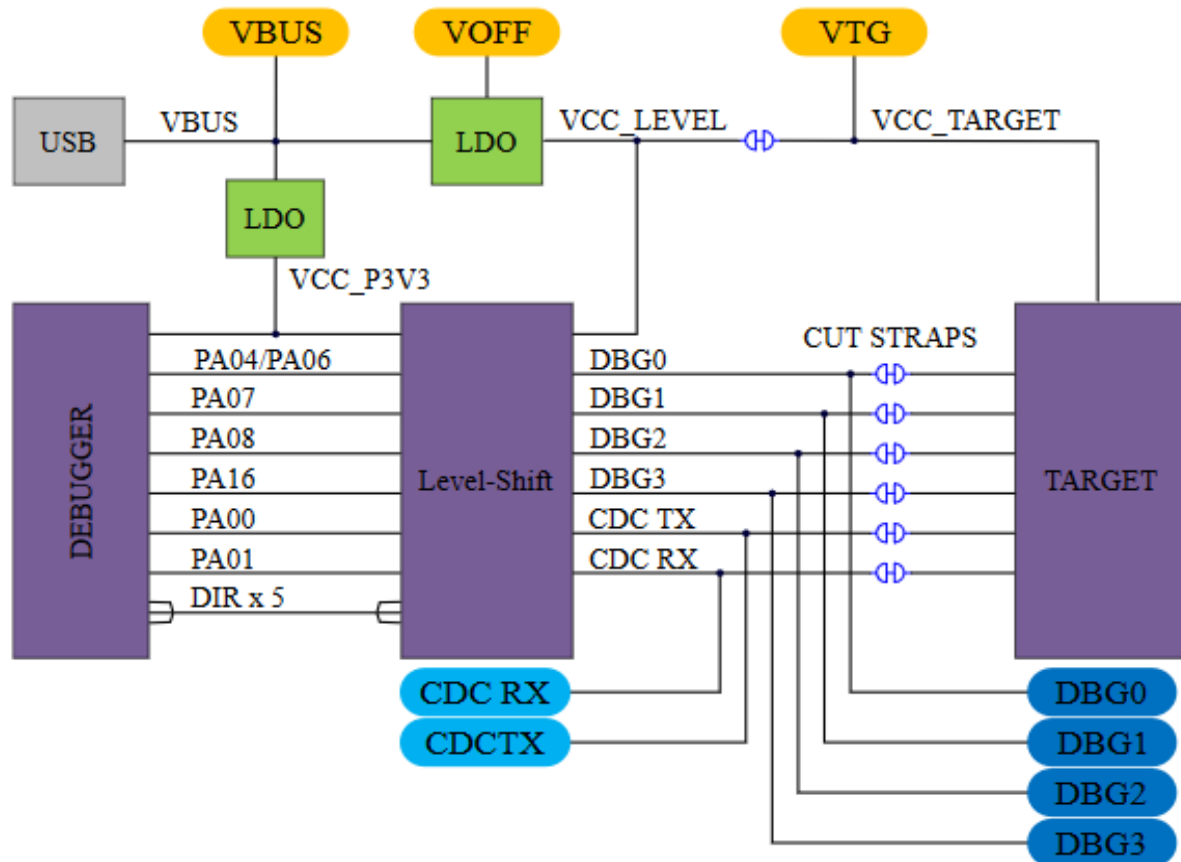

By cutting the GPIO straps with a sharp tool, as shown in the following figure, all I/O connected between the debugger and the PIC32CM JH01 can be disconnected. To disconnect the target regulator, the user need to cut the VTG strap.

Notes:

1. Cutting the connections to the debugger will disable the programming, debugging, and data streaming. The signals will also be disconnected from the board edge next to the on-board debugger section.
2. Solder 0Ω resistors across the footprints, or short-circuit traces with tin solder to reconnect any cut signals.

Figure 3-5. Location of GPIO and VTG Straps

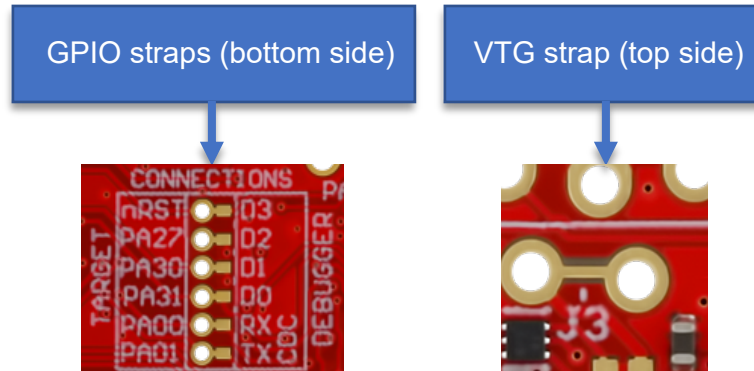

3.5 Current Measurement

The PIC32CM JH01 is connected to the target voltage supply (VTG) through a cut-strap as described in [3.4. Disconnecting the On-Board Debugger](#).

To measure the power consumption of the target and peripherals, cut the strap trace and connect an ammeter across the open. The ammeter can be connected between the target VTG pad edge connector and an external power supply for easy measurement. Alternatively, an external power supply can be used as described in [External Supply](#).



Tip: The nEDBG level shifters will draw a small amount of current even when they are not in use. Disconnect the nEDBG and level shifters as described in [3.4. Disconnecting the On-Board Debugger](#) to prevent any current leakage.

4. Hardware

4.1 Connectors

4.1.1 PIC32CM JH01 Curiosity Nano+ Touch Pinout

Most of the PIC32CM JH01 I/O pins are accessible through the edge connectors on the PIC32CM JH01 Curiosity Nano + Touch Board. The following figure shows the PIC32CM JH01 Curiosity Nano+ Touch's edge connector pinout.

Figure 4-1. PIC32CM JH01 Curiosity Nano+ Touch Pinout

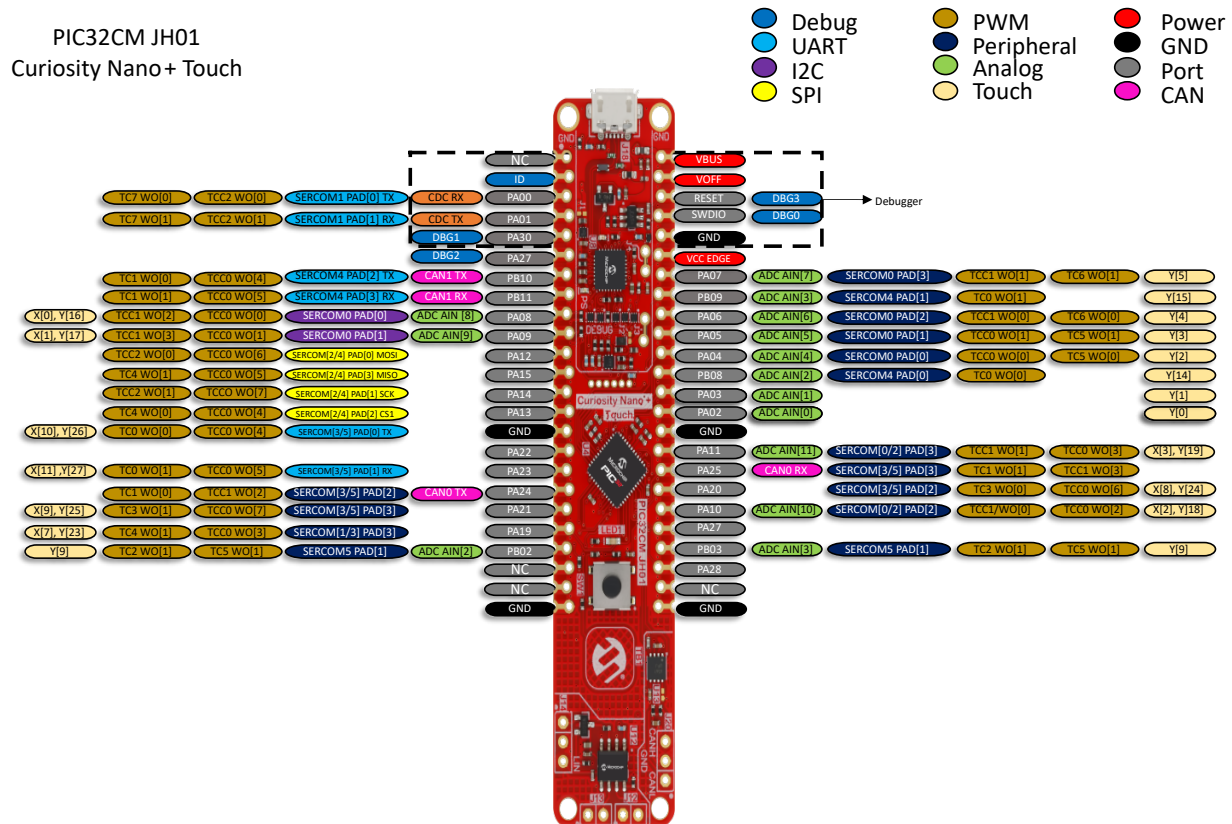

Note: The PA30 and PA31 pins are only available at the edge connector in the debugger section if the cut straps on the bottom have continuity.

4.1.2 PIC32CM JH01 Curiosity Nano+ Touch Base Quick Reference

The following figure shows a simplified reference to enable quicker development with the Curiosity Nano+ Touch Base for Click boards™, AC164162. For additional information, visit <https://www.microchip.com/en-us/development-tool/ac164162>.

Figure 4-2. PIC32CM JH01 Curiosity Nano + Touch Connections to the Curiosity Nano Base for Click board™

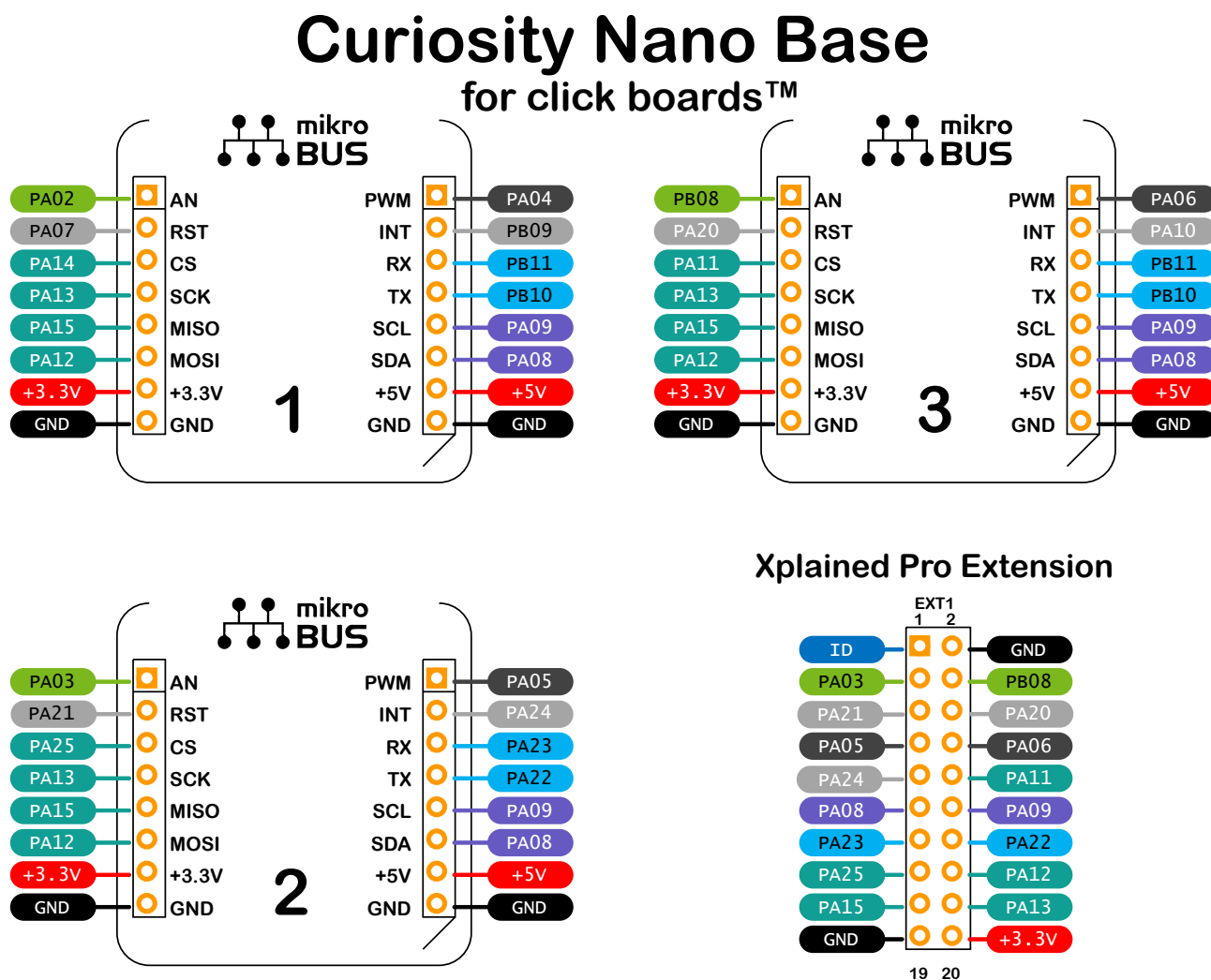

4.2 Peripherals

4.2.1 User LED

One yellow LED is available on the PIC32CM JH01 Curiosity Nano+ Touch Evaluation Kit. The user application can use this LED and is controlled as a GPIO. The LED can be activated by driving the connected I/O line to the GND.

Table 4-1. LED Connection

PIC32CM JH01 pin	Function	Shared Functionality
PA19	Yellow LED	GPIO1 (Pin 20 on the Edge Connector)

4.2.2 Mechanical Button

The PIC32CM JH01 Curiosity Nano+ Touch Evaluation Kit has one mechanical button for a generic users application input. When the switch is pressed, the associated I/O line will be driven to ground (GND).

Table 4-2. Mechanical Switch

PIC32CM JH01 pin	Function	Shared Functionality
PA27	Mech Button	DBG2 and GPIO6 (Pin 29 on the Edge Connector)

4.2.3 Touch Button

The PIC32CM JH01 Curiosity Nano+ Touch Evaluation Kit has one QTouch button with a driven shield. The QTouch button is implemented using the built-in Peripheral Touch Controller (PTC) of the MCU.

These PTC I/O lines are accessible through the edge connector and may be repurposed to GPIO. These PTC I/O lines are accessible through the edge connector and may be repurposed to GPIO. For this, users need to desolder the R20 and R40 pins, and then populate the R41 and R42 pins.

Table 4-3. Touch Button

PIC32CM JH01 pin	Function	Shared Functionality
PB02	QTouch Button	GPIO4 (Pin 21 on the Edge Connector)
PB03	QTouch Button Shield	GPIO5 (Pin 28 on the Edge Connector)

4.2.4 CAN Interface

The PIC32CM JH01 Curiosity Nano+ Touch Evaluation Kit has a CAN interface on the board. CAN is connected to an on-board ATA6561 CAN physical-layer transceiver. It performs communication according to ISO 11898-1 (Bosch CAN specification 2.0 -part A, B) and Bosch™ CAN FD specification V1.0.

The table below provides connections between the PIC32CM JH01 and ATA6561.

Table 4-4. CAN Interface

PIC32CM JH01 pin	Function	Shared Functionality
PB22	CAN TX	None
PB23	CAN RX	None

4.2.5 LIN Interface

The PIC32CM JH01 Curiosity Nano+ Touch Evaluation Kit has a LIN interface, which is connected to an on-board ATA6661 LIN physical-layer transceiver in accordance with the LIN specification 2.0.

The table below provides connection details between the PIC32CM JH01 and the ATA6661.

Table 4-5. LIN Interface

PIC32CM JH01 pin	Function	Shared Functionality
PA16	LIN TX	None
PA17	LIN RX	None
PA18	LIN EN	None

4.3 On-Board Debugger Implementation

The PIC32CM JH01 Curiosity Nano+ Touch Evaluation Kit features an on-board debugger that can be used to program and debug the PIC32CM JH01 through a serial wire debug (SWD) line. The on-board debugger also includes a virtual COM port interface over UART and DGI GPIO. Microchip's Data Visualizer can be used as a front-end for the CDC and DGI GPIO. MPLAB X IDE can be used as a nEDBG front-end for programming and debugging.

4.3.1 On-Board Debugger Connections

The following table provides the connection details between the target and the debugger section. All connections between the target and the debugger are tri-stated if the debugger is not actively using the interface.

For additional information on how to use the capabilities of the on-board debugger, refer to the [Curiosity Nano+ Touch](#).

Table 4-6. Connection Details between the Target and Debugger

PIC32CM JH01 pin	Debugger pin	Function	Shared Functionality
PA00	CDC TX	UART TX (PIC32CM JH01 RX line)	Edge Connector
PA01	CDC RX	UART RX (PIC32CM JH01 TX line)	Edge Connector
PA31	DBG0	SWDATA	Edge Connector
PA30	DBG1	SWCLK	Edge Connector
PA27	DBG2	GPIO	Mech Button and Edge Connector
nRESET	DBG3	nRESET	Edge Connector
VCC_TARGET	VCC_LEVEL	1.7 - 3.6V	Edge Connector
GND	GND	Common Ground	Edge Connector

5. Hardware Revision History

This document provides the latest available revision of the kit. This chapter describes the information about known issues, a revision history of older revisions, and how older revisions differ from the latest revision.

5.1 Identifying Product ID and Revision

The revision and product identifier of Curiosity Nano+ Touch boards can be found at the sticker on the bottom of the PCB. The revision information is also available through the MPLAB X IDE.

By connecting a Curiosity Nano+ Touch Board to a computer with MPLAB X IDE running, an information window will pop up. The serial number string shown in the kit has the following format: "nnnnrrssssssss".

Where,

n = product identifier

r = revision

s = serial number

The first six digits of the serial number, which is listed under kit details, contain the product identifier and revision. The same information can be found on the sticker on the bottom of the PCB. The printed identifier on the board typically has the identifier and revision in plain text as A09-nnnn\rr. Where, nnnn is the identifier and rr is the revision.

Boards with limited space have a sticker with only a QR code. The QR code contains the serial number string.

6. Schematics

PIC32CM JH01 Curiosity Nano + Touch

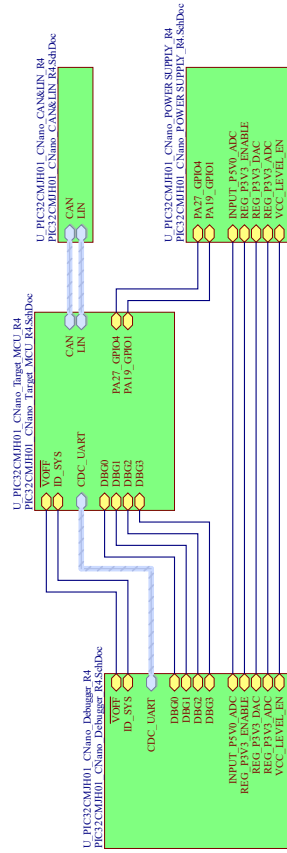

LABEL
 Cannot open file
 C:\Users\j...
 M...
 M...
 [DATE yyyy/mm/dd]
 PCB/LABEL16Xmm

U_PIC32CMH01_CName_Revision_History_R4
 PIC32CMH01_CName_Revision_History_R4SdbDoc

Power Supply

A - For current measurements using the on-board power supply, this strap must be cut and an external power supply used. Leakage back through the switch is in the micro ampere range.

MIC5353:
 Vin: 2.6V to 6V
 Vout: 0.5-1V
 Iout: 500mA
 Dropout (typical): 50mV @ 150mA,
 160mV @ 500mA
 Thermal shutdown and current limit

Maximum output voltage is limited by the regulator. Voltage drop (Vmax = Vin - dropout)

P - DEBUG_USB_PSW0 comes from DEBUGGER_USB connector. VS power must be the LIN transceiver comes from external regulated power supply.

MIC5353:
 Vin: 2.6V to 6V
 Vout: 0.5-1V
 Iout: 500mA
 Dropout (typical): 50mV @ 150mA,
 160mV @ 500mA
 Thermal shutdown and current limit

Maximum output voltage is limited by the regulator. Voltage drop (Vmax = Vin - dropout)

Debugger

A - Adjustable output and limitations:
 - The debugger can adjust the output voltage of the regulator between 0.5V and 1.1V to the target.
 - The selected target operating voltage level of 1.65V and will limit the minimum operating voltage allowed for the target to still allow communication.
 - The output switch has a minimal voltage level of 1.70V and will limit the minimum voltage delivered to the target.
 - Firmware configuration will limit the voltage range to be within the target specification.
 - Firmware feature: The output voltage will adjust the output voltage accuracy to within 0.5%.

B - Programming connector for factory programming of Debugger.

MIC5353:
 Vin: 2.5V to 5.5V
 Vout: 0.5-1V
 Iout: 500mA
 Dropout: 260mV @ 500mA

Target MCU

A - CAN_TX is output from the debugger. CAN_RX is input to the target device.
 - The debugger can adjust the output voltage of the regulator between 0.5V and 1.1V to the target.
 - The selected target operating voltage level of 1.65V and will limit the minimum operating voltage allowed for the target to still allow communication.
 - The output switch has a minimal voltage level of 1.70V and will limit the minimum voltage delivered to the target.
 - Firmware configuration will limit the voltage range to be within the target specification.
 - Firmware feature: The output voltage will adjust the output voltage accuracy to within 0.5%.

LABEL
 Cannot open file
 C:\Users\j...
 M...
 M...
 [DATE yyyy/mm/dd]
 PCB/LABEL16Xmm

POWER SUPPLY

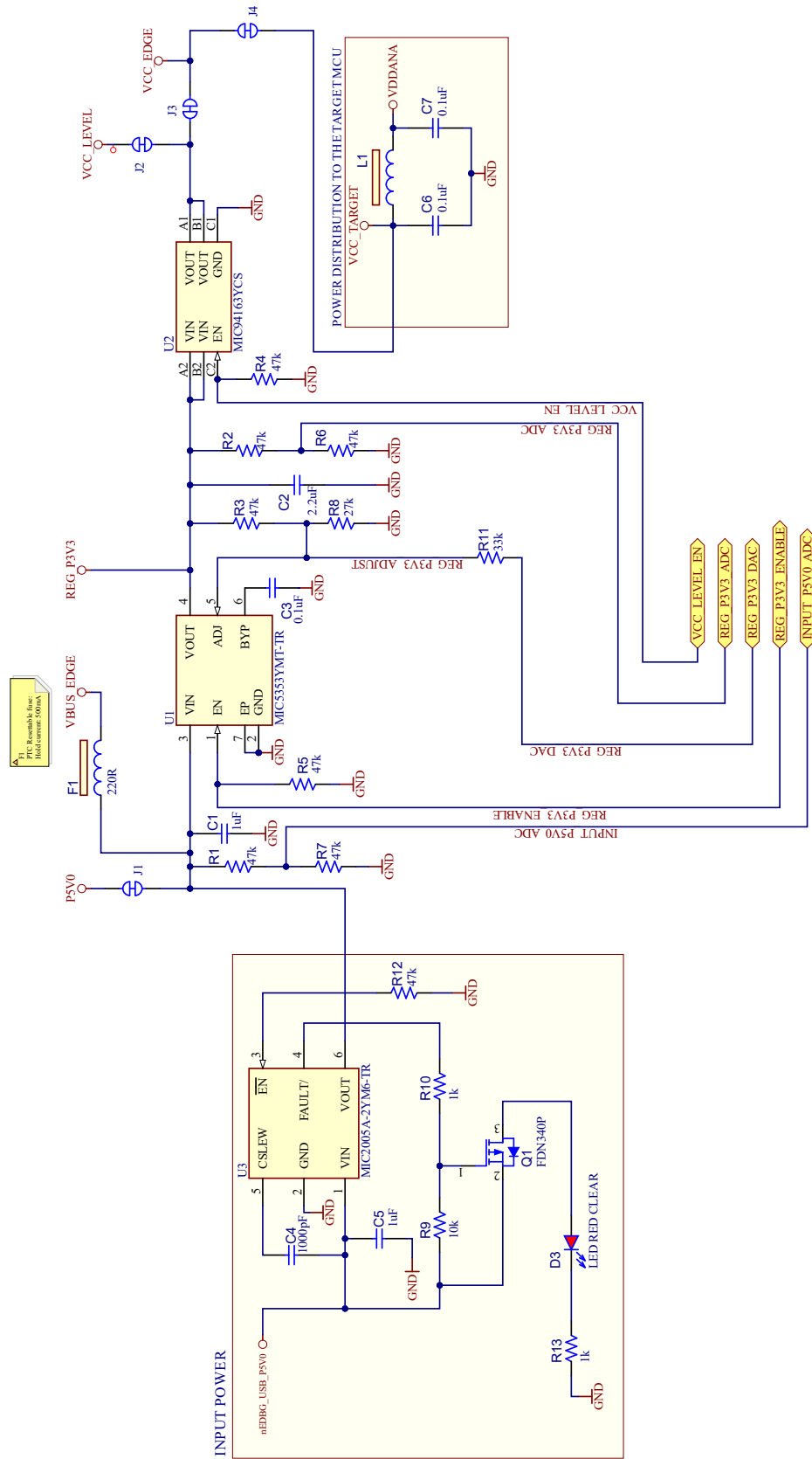

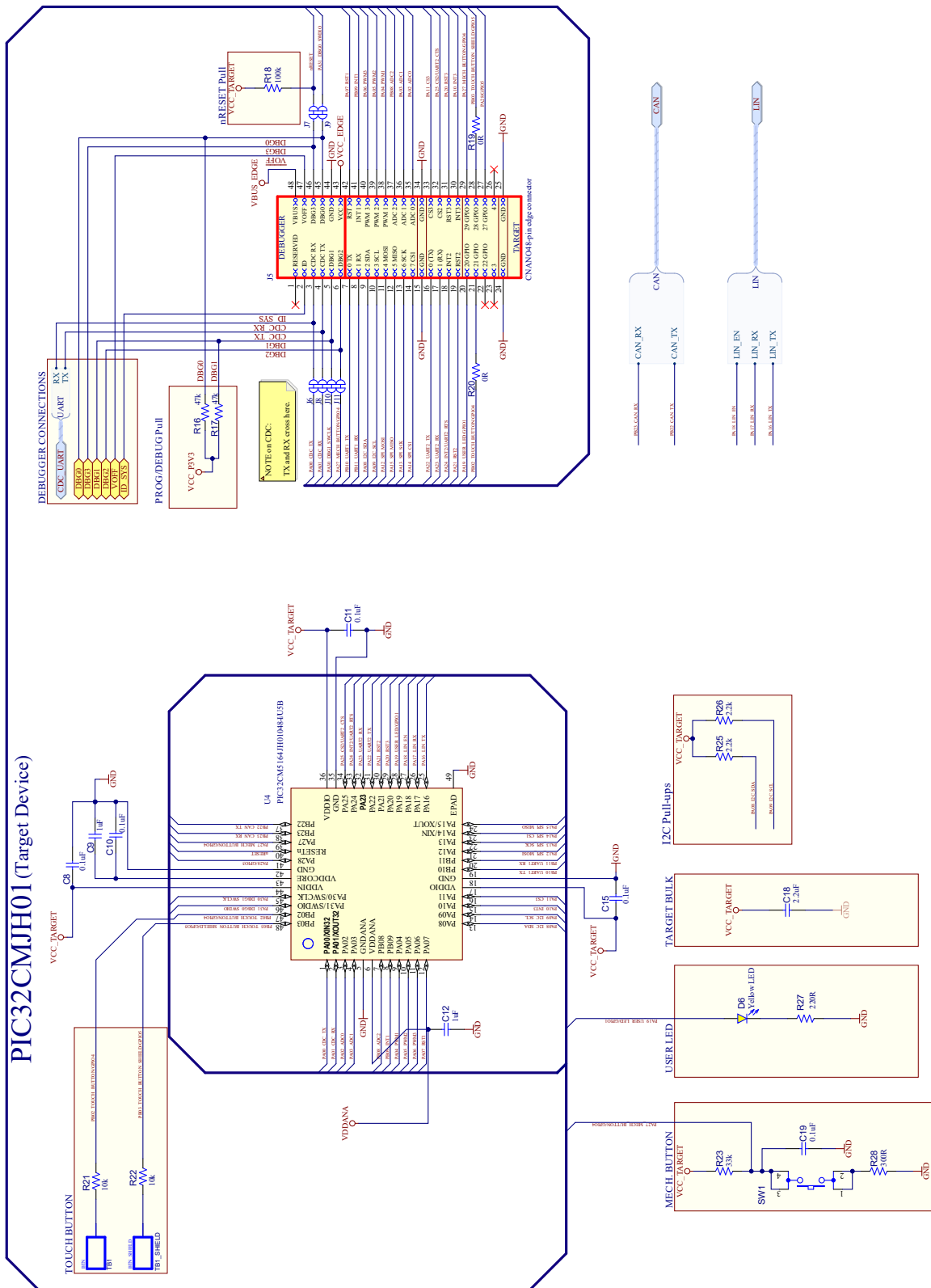

LIN Interface

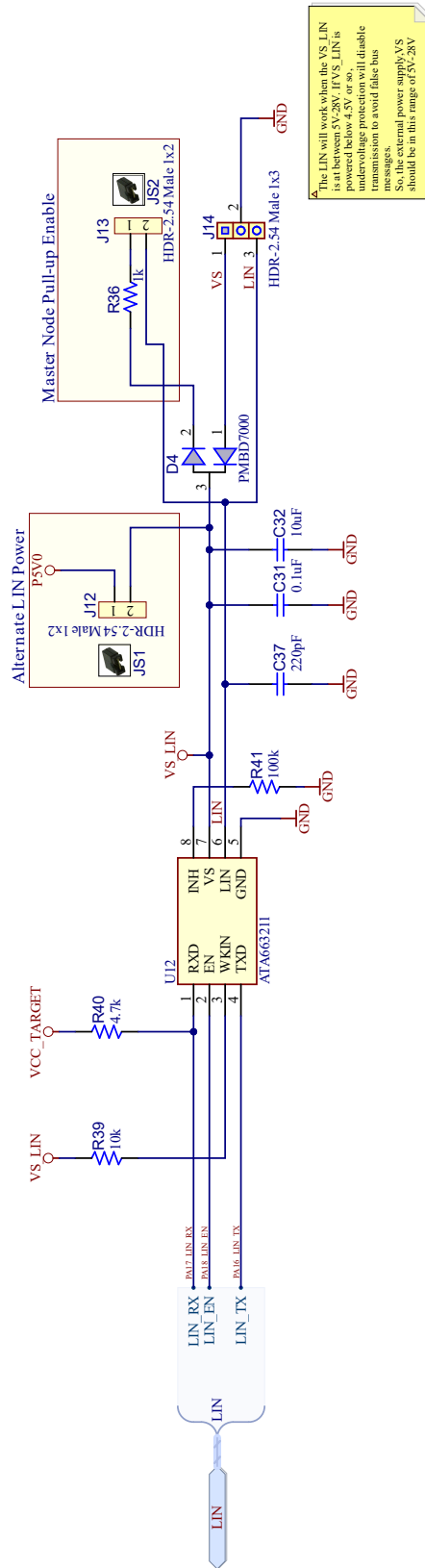

CAN Interface

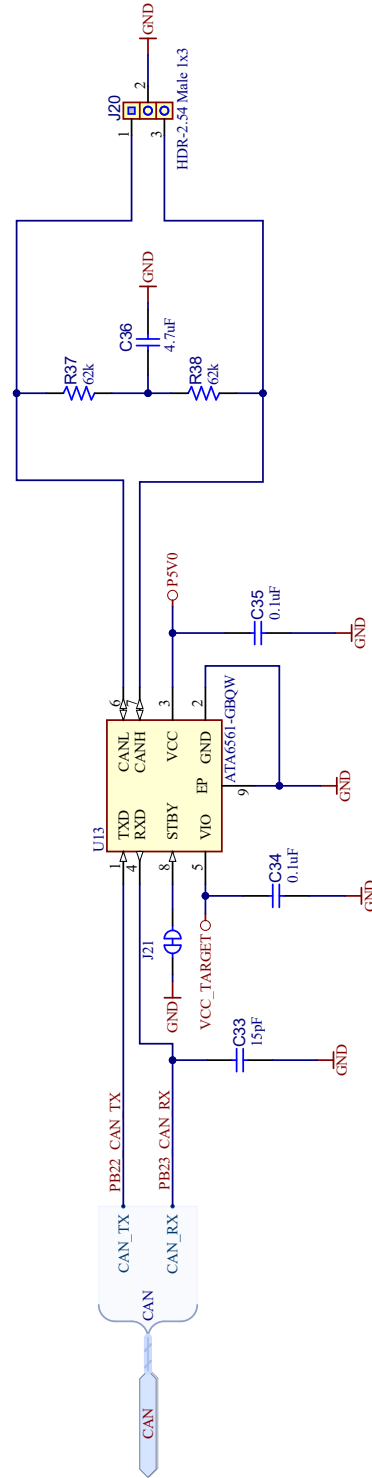

DEBUGGER

Interface	SWD	TARGET
Signal	UARTRX	UARTTX
	CDCRX	UARTTX
	DBG0	SWDAT
	DBG1	SWCLK
	DBG2	GPFD
	DBG3	nRESET
	VCC	3.3V

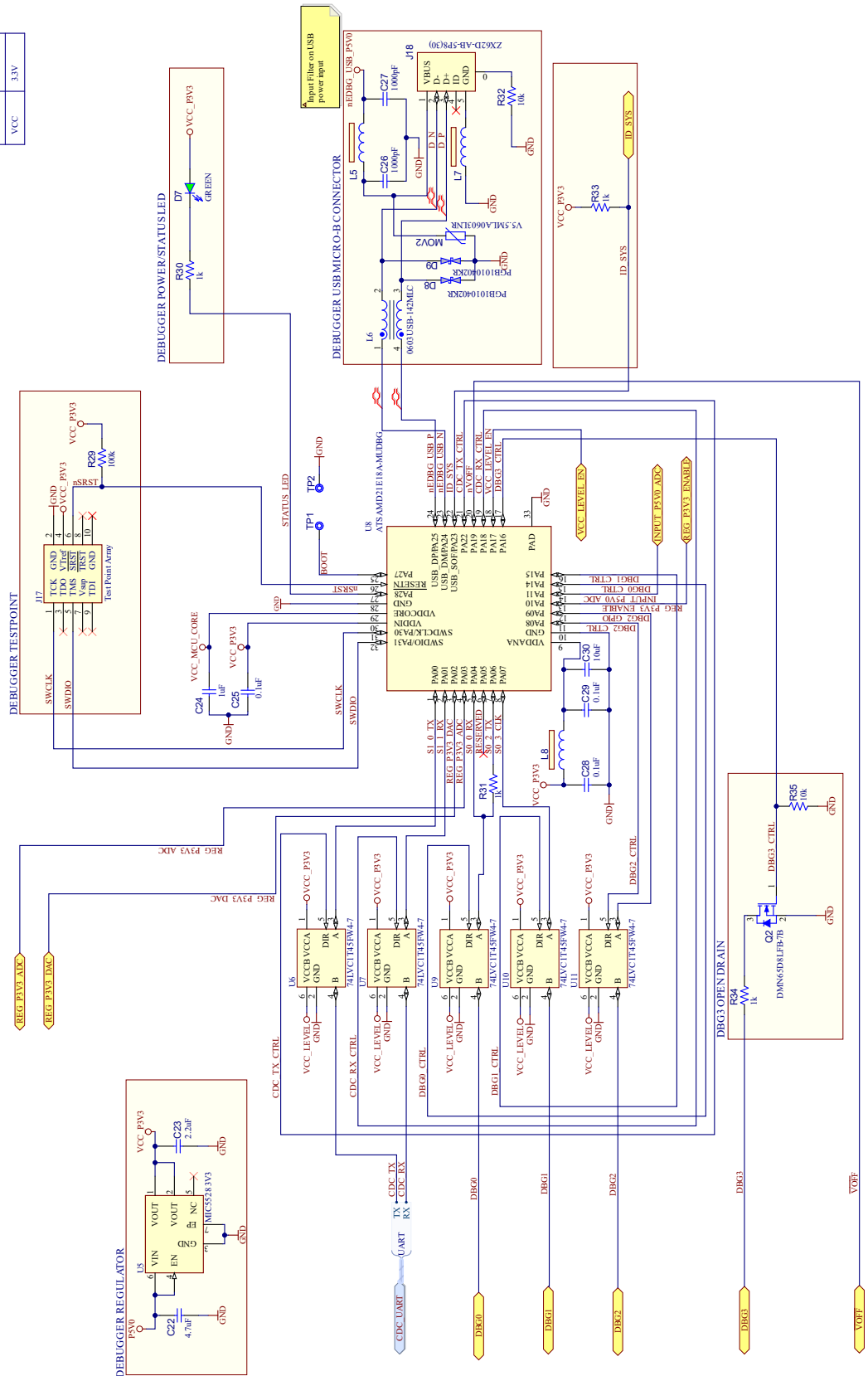

7. Revision History

Revision B - 07/2024

The following updates were performed in this revision:

Preface	Changed "EV29G58A/4" by "EV29G58A/5". Updated the figure <i>PIC32CM JH01 Curiosity Nano+ Touch Evaluation Kit</i> .
1. Introduction	Updated Figure 1-1 in 1.2. Kit Overview .
3. Curiosity Nano+ Touch	Updated Figure 3-5 in 3.4. Disconnecting the On-Board Debugger .
4. Hardware	Updated Figure 4-1 in 4.1.1. PIC32CM JH01 Curiosity Nano+ Touch Pinout .

Revision A - 01/2024

This is the Initial released version of this document.

Microchip Information

The Microchip Website

Microchip provides online support via our website at www.microchip.com/. This website is used to make files and information easily available to customers. Some of the content available includes:

- **Product Support** – Data sheets and errata, application notes and sample programs, design resources, user’s guides and hardware support documents, latest software releases and archived software
- **General Technical Support** – Frequently Asked Questions (FAQs), technical support requests, online discussion groups, Microchip design partner program member listing
- **Business of Microchip** – Product selector and ordering guides, latest Microchip press releases, listing of seminars and events, listings of Microchip sales offices, distributors and factory representatives

Product Change Notification Service

Microchip’s product change notification service helps keep customers current on Microchip products. Subscribers will receive email notification whenever there are changes, updates, revisions or errata related to a specified product family or development tool of interest.

To register, go to www.microchip.com/pcn and follow the registration instructions.

Customer Support

Users of Microchip products can receive assistance through several channels:

- Distributor or Representative
- Local Sales Office
- Embedded Solutions Engineer (ESE)
- Technical Support

Customers should contact their distributor, representative or ESE for support. Local sales offices are also available to help customers. A listing of sales offices and locations is included in this document.

Technical support is available through the website at: www.microchip.com/support

Microchip Devices Code Protection Feature

Note the following details of the code protection feature on Microchip products:

- Microchip products meet the specifications contained in their particular Microchip Data Sheet.
- Microchip believes that its family of products is secure when used in the intended manner, within operating specifications, and under normal conditions.
- Microchip values and aggressively protects its intellectual property rights. Attempts to breach the code protection features of Microchip product is strictly prohibited and may violate the Digital Millennium Copyright Act.
- Neither Microchip nor any other semiconductor manufacturer can guarantee the security of its code. Code protection does not mean that we are guaranteeing the product is “unbreakable”. Code protection is constantly evolving. Microchip is committed to continuously improving the code protection features of our products.

Legal Notice

This publication and the information herein may be used only with Microchip products, including to design, test, and integrate Microchip products with your application. Use of this information in any other manner violates these terms. Information regarding device applications is provided only for your convenience and may be superseded by updates. It is your responsibility to ensure

that your application meets with your specifications. Contact your local Microchip sales office for additional support or, obtain additional support at www.microchip.com/en-us/support/design-help/client-support-services.

THIS INFORMATION IS PROVIDED BY MICROCHIP "AS IS". MICROCHIP MAKES NO REPRESENTATIONS OR WARRANTIES OF ANY KIND WHETHER EXPRESS OR IMPLIED, WRITTEN OR ORAL, STATUTORY OR OTHERWISE, RELATED TO THE INFORMATION INCLUDING BUT NOT LIMITED TO ANY IMPLIED WARRANTIES OF NON-INFRINGEMENT, MERCHANTABILITY, AND FITNESS FOR A PARTICULAR PURPOSE, OR WARRANTIES RELATED TO ITS CONDITION, QUALITY, OR PERFORMANCE.

IN NO EVENT WILL MICROCHIP BE LIABLE FOR ANY INDIRECT, SPECIAL, PUNITIVE, INCIDENTAL, OR CONSEQUENTIAL LOSS, DAMAGE, COST, OR EXPENSE OF ANY KIND WHATSOEVER RELATED TO THE INFORMATION OR ITS USE, HOWEVER CAUSED, EVEN IF MICROCHIP HAS BEEN ADVISED OF THE POSSIBILITY OR THE DAMAGES ARE FORESEEABLE. TO THE FULLEST EXTENT ALLOWED BY LAW, MICROCHIP'S TOTAL LIABILITY ON ALL CLAIMS IN ANY WAY RELATED TO THE INFORMATION OR ITS USE WILL NOT EXCEED THE AMOUNT OF FEES, IF ANY, THAT YOU HAVE PAID DIRECTLY TO MICROCHIP FOR THE INFORMATION.

Use of Microchip devices in life support and/or safety applications is entirely at the buyer's risk, and the buyer agrees to defend, indemnify and hold harmless Microchip from any and all damages, claims, suits, or expenses resulting from such use. No licenses are conveyed, implicitly or otherwise, under any Microchip intellectual property rights unless otherwise stated.

Trademarks

The Microchip name and logo, the Microchip logo, Adaptec, AVR, AVR logo, AVR Freaks, BesTime, BitCloud, CryptoMemory, CryptoRF, dsPIC, flexPWR, HELDO, IGLOO, JukeBlox, KeeLoq, Kleer, LANCheck, LinkMD, maXStylus, maXTouch, MediaLB, megaAVR, Microsemi, Microsemi logo, MOST, MOST logo, MPLAB, OptoLyzer, PIC, picoPower, PICSTART, PIC32 logo, PolarFire, Prochip Designer, QTouch, SAM-BA, SenGenuity, SpyNIC, SST, SST Logo, SuperFlash, Symmetricom, SyncServer, Tachyon, TimeSource, tinyAVR, UNI/O, Vectron, and XMEGA are registered trademarks of Microchip Technology Incorporated in the U.S.A. and other countries.

AgileSwitch, ClockWorks, The Embedded Control Solutions Company, EtherSynch, Flashtec, Hyper Speed Control, HyperLight Load, Libero, motorBench, mTouch, Powermite 3, Precision Edge, ProASIC, ProASIC Plus, ProASIC Plus logo, Quiet-Wire, SmartFusion, SyncWorld, TimeCesium, TimeHub, TimePictra, TimeProvider, and ZL are registered trademarks of Microchip Technology Incorporated in the U.S.A.

Adjacent Key Suppression, AKS, Analog-for-the-Digital Age, Any Capacitor, AnyIn, AnyOut, Augmented Switching, BlueSky, BodyCom, Clockstudio, CodeGuard, CryptoAuthentication, CryptoAutomotive, CryptoCompanion, CryptoController, dsPICDEM, dsPICDEM.net, Dynamic Average Matching, DAM, ECAN, Espresso T1S, EtherGREEN, EyeOpen, GridTime, IdealBridge, IGaT, In-Circuit Serial Programming, ICSP, INICnet, Intelligent Paralleling, IntelliMOS, Inter-Chip Connectivity, JitterBlocker, Knob-on-Display, MarginLink, maxCrypto, maxView, memBrain, Minda, MiWi, MPASM, MPF, MPLAB Certified logo, MPLIB, MPLINK, mSiC, MultiTRAK, NetDetach, Omniscient Code Generation, PICDEM, PICDEM.net, PICkit, PICtail, Power MOS IV, Power MOS 7, PowerSmart, PureSilicon, QMatrix, REAL ICE, Ripple Blocker, RTAX, RTG4, SAM-ICE, Serial Quad I/O, simpleMAP, SimpliPHY, SmartBuffer, SmartHLS, SMART-I.S., storClad, SQI, SuperSwitcher, SuperSwitcher II, Switchtec, SynchroPHY, Total Endurance, Trusted Time, TSHARC, Turing, USBCheck, VariSense, VectorBlox, VeriPHY, ViewSpan, WiperLock, XpressConnect, and ZENA are trademarks of Microchip Technology Incorporated in the U.S.A. and other countries.

SQTP is a service mark of Microchip Technology Incorporated in the U.S.A.

The Adaptec logo, Frequency on Demand, Silicon Storage Technology, and Symmcom are registered trademarks of Microchip Technology Inc. in other countries.

GestIC is a registered trademark of Microchip Technology Germany II GmbH & Co. KG, a subsidiary of Microchip Technology Inc., in other countries.

All other trademarks mentioned herein are property of their respective companies.

© 2024, Microchip Technology Incorporated and its subsidiaries. All Rights Reserved.

ISBN: 978-1-6683-4856-7

Quality Management System

For information regarding Microchip's Quality Management Systems, please visit www.microchip.com/quality.

Worldwide Sales and Service

AMERICAS	ASIA/PACIFIC	ASIA/PACIFIC	EUROPE
<p>Corporate Office 2355 West Chandler Blvd. Chandler, AZ 85224-6199 Tel: 480-792-7200 Fax: 480-792-7277 Technical Support: www.microchip.com/support Web Address: www.microchip.com</p> <p>Atlanta Duluth, GA Tel: 678-957-9614 Fax: 678-957-1455</p> <p>Austin, TX Tel: 512-257-3370</p> <p>Boston Westborough, MA Tel: 774-760-0087 Fax: 774-760-0088</p> <p>Chicago Itasca, IL Tel: 630-285-0071 Fax: 630-285-0075</p> <p>Dallas Addison, TX Tel: 972-818-7423 Fax: 972-818-2924</p> <p>Detroit Novi, MI Tel: 248-848-4000</p> <p>Houston, TX Tel: 281-894-5983</p> <p>Indianapolis Noblesville, IN Tel: 317-773-8323 Fax: 317-773-5453 Tel: 317-536-2380</p> <p>Los Angeles Mission Viejo, CA Tel: 949-462-9523 Fax: 949-462-9608 Tel: 951-273-7800</p> <p>Raleigh, NC Tel: 919-844-7510</p> <p>New York, NY Tel: 631-435-6000</p> <p>San Jose, CA Tel: 408-735-9110 Tel: 408-436-4270</p> <p>Canada - Toronto Tel: 905-695-1980 Fax: 905-695-2078</p>	<p>Australia - Sydney Tel: 61-2-9868-6733</p> <p>China - Beijing Tel: 86-10-8569-7000</p> <p>China - Chengdu Tel: 86-28-8665-5511</p> <p>China - Chongqing Tel: 86-23-8980-9588</p> <p>China - Dongguan Tel: 86-769-8702-9880</p> <p>China - Guangzhou Tel: 86-20-8755-8029</p> <p>China - Hangzhou Tel: 86-571-8792-8115</p> <p>China - Hong Kong SAR Tel: 852-2943-5100</p> <p>China - Nanjing Tel: 86-25-8473-2460</p> <p>China - Qingdao Tel: 86-532-8502-7355</p> <p>China - Shanghai Tel: 86-21-3326-8000</p> <p>China - Shenyang Tel: 86-24-2334-2829</p> <p>China - Shenzhen Tel: 86-755-8864-2200</p> <p>China - Suzhou Tel: 86-186-6233-1526</p> <p>China - Wuhan Tel: 86-27-5980-5300</p> <p>China - Xian Tel: 86-29-8833-7252</p> <p>China - Xiamen Tel: 86-592-2388138</p> <p>China - Zhuhai Tel: 86-756-3210040</p>	<p>India - Bangalore Tel: 91-80-3090-4444</p> <p>India - New Delhi Tel: 91-11-4160-8631</p> <p>India - Pune Tel: 91-20-4121-0141</p> <p>Japan - Osaka Tel: 81-6-6152-7160</p> <p>Japan - Tokyo Tel: 81-3-6880-3770</p> <p>Korea - Daegu Tel: 82-53-744-4301</p> <p>Korea - Seoul Tel: 82-2-554-7200</p> <p>Malaysia - Kuala Lumpur Tel: 60-3-7651-7906</p> <p>Malaysia - Penang Tel: 60-4-227-8870</p> <p>Philippines - Manila Tel: 63-2-634-9065</p> <p>Singapore Tel: 65-6334-8870</p> <p>Taiwan - Hsin Chu Tel: 886-3-577-8366</p> <p>Taiwan - Kaohsiung Tel: 886-7-213-7830</p> <p>Taiwan - Taipei Tel: 886-2-2508-8600</p> <p>Thailand - Bangkok Tel: 66-2-694-1351</p> <p>Vietnam - Ho Chi Minh Tel: 84-28-5448-2100</p>	<p>Austria - Wels Tel: 43-7242-2244-39 Fax: 43-7242-2244-393</p> <p>Denmark - Copenhagen Tel: 45-4485-5910 Fax: 45-4485-2829</p> <p>Finland - Espoo Tel: 358-9-4520-820</p> <p>France - Paris Tel: 33-1-69-53-63-20 Fax: 33-1-69-30-90-79</p> <p>Germany - Garching Tel: 49-8931-9700</p> <p>Germany - Haan Tel: 49-2129-3766400</p> <p>Germany - Heilbronn Tel: 49-7131-72400</p> <p>Germany - Karlsruhe Tel: 49-721-625370</p> <p>Germany - Munich Tel: 49-89-627-144-0 Fax: 49-89-627-144-44</p> <p>Germany - Rosenheim Tel: 49-8031-354-560</p> <p>Israel - Ra'anana Tel: 972-9-744-7705</p> <p>Italy - Milan Tel: 39-0331-742611 Fax: 39-0331-466781</p> <p>Italy - Padova Tel: 39-049-7625286</p> <p>Netherlands - Drunen Tel: 31-416-690399 Fax: 31-416-690340</p> <p>Norway - Trondheim Tel: 47-72884388</p> <p>Poland - Warsaw Tel: 48-22-3325737</p> <p>Romania - Bucharest Tel: 40-21-407-87-50</p> <p>Spain - Madrid Tel: 34-91-708-08-90 Fax: 34-91-708-08-91</p> <p>Sweden - Gothenberg Tel: 46-31-704-60-40</p> <p>Sweden - Stockholm Tel: 46-8-5090-4654</p> <p>UK - Wokingham Tel: 44-118-921-5800 Fax: 44-118-921-5820</p>