

High Voltage Dual EL Lamp Driver IC

Features

- ▶ Independent input control for lamp selection
- ▶ Split supply capability
- ▶ Patented output timing
- ▶ One miniature inductor to power both lamps
- ▶ Low shutdown current
- ▶ Wide input voltage range 2.0 to 5.8V
- ▶ Output voltage regulation
- ▶ No SCR output
- ▶ Available in small packages (10-lead MSOP and 10-lead DFN)

Applications

- ▶ Mobile cellular phones, dual display
- ▶ Keypad and LCD backlighting
- ▶ Portable instrumentation
- ▶ Dual segment lamps
- ▶ Hand held wireless communication devices

General Description

The Supertex HV839 is a high voltage driver designed for driving two EL lamps with a combined area of 3.5in². The input supply voltage range is from 2.0 to 5.8V. The device is designed to reduce the amount of audible noise emitted by the lamp. This device uses a single inductor and minimum number of passive components to drive two EL lamps. The nominal regulated output voltage of ±90V is applied to the EL lamps. The two EL lamps can be turned ON and OFF by the two logic input control pins, C1 and C2. The device is disabled when both C1 and C2 (pins 1 and 4) are at logic low.

The HV839 has an internal oscillator, a switching MOSFET, and two high voltage EL lamp drivers. An external resistor connected between the RSW-Osc pin and the voltage supply pin VDD sets the frequency for the switching MOSFET. The EL lamp driver frequency is set by dividing the MOSFET switching frequency by 128. An external inductor is connected between the LX and the VDD pins. Depending on the EL lamp size, a 1.0 to 10.0nF, 100V capacitor is connected between CS and GROUND. The two EL lamps are connected between EL1 to COM and EL2 to COM. The switching MOSFET charges the external inductor and discharges it into the capacitor at CS. The voltage at CS increases. Once the voltage at CS reaches a nominal value of 90V, the switching MOSFET is turned OFF to conserve power. The outputs EL1 to COM and EL2 to COM are configured as H bridges and switch in opposite states to achieve 180V across the EL lamp.

Typical Application Circuit

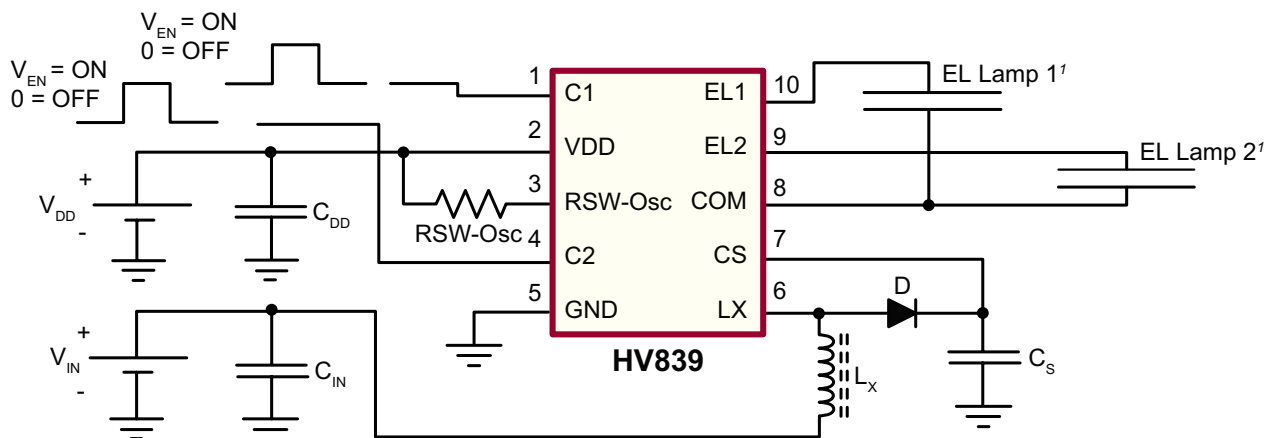

1. The bigger sized lamp should be tied to EL1 and the smaller sized lamp to EL2 terminals (pins 10 and 9 respectively)

Ordering Information

Device	Package Options	
	10-Lead DFN 3.00x3.00mm body 1.0mm height (max) 0.50mm pitch	10-Lead MSOP 3.00x3.00mm body 1.10mm height (max) 0.50mm pitch
HV839	HV839K6-G	HV839MG-G

-G indicates package is RoHS compliant ('Green')



Absolute Maximum Ratings

Parameter	Value
V _{DD} , supply voltage	-0.5V to +7.5V
V _{CS} , output voltage	-0.5V to +120V
Storage temperature	-65°C to +150°C
Operating temperature	-40°C to +85°C

Absolute Maximum Ratings are those values beyond which damage to the device may occur. Functional operation under these conditions is not implied. Continuous operation of the device at the absolute rating level may affect device reliability. All voltages are referenced to device ground.

Thermal Resistance

Package	θ_{ja}
10-Lead DFN	60°C/W
10-Lead MSOP	400°C/W

Note:

Mounted on FR4 board, (25mm x 25mm x 1.57mm)

Pin Configurations

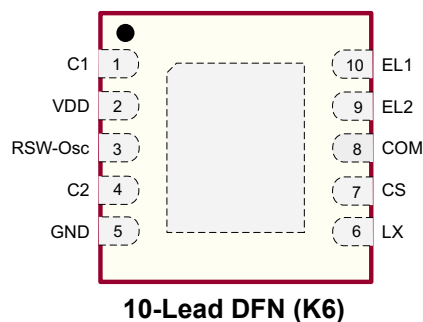

10-Lead DFN (K6)

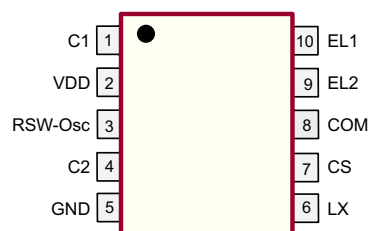

10-Lead MSOP (MG)

Product Marking

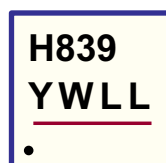

Y = Last Digit of Year Sealed
W = Code for Week Sealed
L = Lot Number
— = "Green" Packaging

Package may or may not include the following marks: Si or

10-Lead DFN (K6)

Top Marking

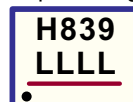

L = Lot Number
YY = Year Sealed
WW = Week Sealed
— = "Green" Packaging

Bottom Marking



Package may or may not include the following marks: Si or

10-Lead MSOP (MG)

Recommended Operating Conditions

Sym	Parameter	Min	Typ	Max	Units	Conditions
V _{DD}	Supply voltage	2.0	-	5.8	V	---
T _A	Operating temperature	-40	-	85	°C	---

DC Electrical Characteristics

(Over recommended operating conditions unless otherwise specified. $V_{DD} = 2.6$ to $5.5V$, $T_A = 25^\circ C$)

Sym	Parameter	Min	Typ	Max	Units	Conditions
$R_{DS(ON)}$	On resistance switching transformer	-	-	6.0	Ω	$I = 100mA$
V_{DD}	Input voltage range	2.0	-	5.8	V	---
V_{CS}	Output regulation voltage	80	90	100	V	$V_{DD} = 2.0$ to $5.8V$
V_{DIFF}	Differential peak to peak voltage (EL1 to COM, EL2 to COM)	160	180	200	V	$V_{DD} = 2.0$ to $5.8V$
I_{DDQ}	Quiescent V_{DD} supply current	-	-	150	nA	$C1 = C2 = 0$ to $0.1V$
		-	-	500	nA	$C1 = C2 = 0.1$ to $0.3V$
I_{DD}	Input current to the VDD pin	-	-	190	μA	$V_{DD} = 2.0$ to $5.8V$
I_{IN}	Input current including inductor current when driving both lamps	-	-	60	mA	$V_{IN} = 3.0V$, See Fig. 1 $T_A = -40^\circ C$ to $+85^\circ C$
		-	45	53	mA	$V_{IN} = 3.0V$, See Fig. 1 $T_A = +25^\circ C$
V_{CS}	Output voltage on VCS when driving both lamps	-	76.2	-	V	$V_{IN} = 3.0V$, See Fig. 1
V_{DIFF}	Differential output peak to peak voltage (EL1 to COM, EL2 to COM)	-	152.4	-	V	$V_{IN} = 3.0V$, See Fig. 1
f_{EL}	V_{DIF} output drive frequency	440	500	560	kHz	$V_{IN} = 3.0V$, See Fig. 1
f_{SW}	Switching transistor frequency	56.3	64	71.7	kHz	$V_{IN} = 3.0V$, See Fig. 1
$f_{SWDRIFT}$	Switching transistor frequency drift	-	-	± 5.0	kHz	$T_A = -40^\circ C$ to $+85^\circ C$
D	Switching transistor duty cycle	85	-	89	%	---
I_{IL}	Input logic low current going into the control pin	-	-	-0.6	μA	$V_{DD} = 2.0$ to $5.8V$
I_{IH}	Input logic high current going into the control pin	-	-	0.6	μA	$V_{DD} = 2.0$ to $5.8V$
V_{EN-L}	Logic input low voltage	0	-	0.3	V	---
V_{EN-H}	Logic input high voltage	1.5	-	V_{DD}	V	---

Functional Block Diagram

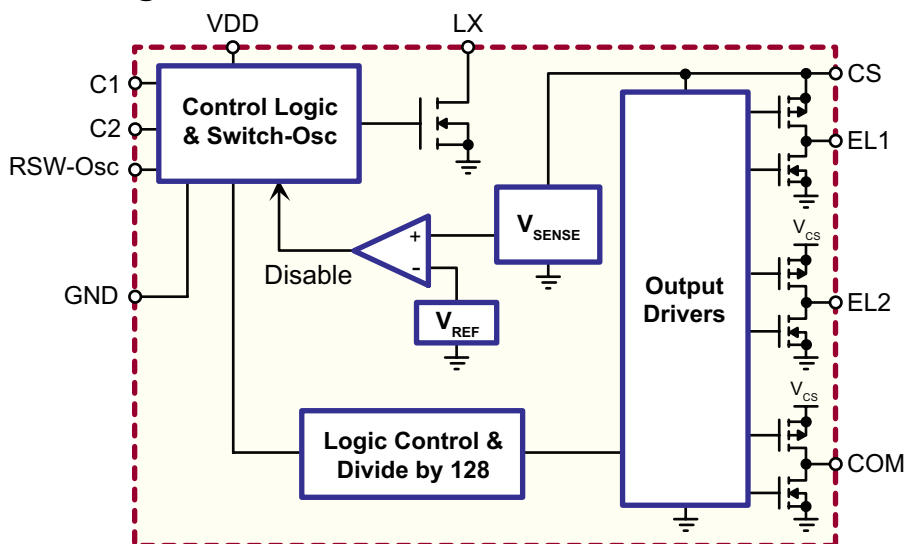

Function Table

C1	C2	EL1	EL2	COM	IC
0	0	Hi Z	Hi Z	Hi Z	OFF
0	1	Hi Z	ON	ON	ON
1	0	ON	Hi Z	ON	ON
1	1	ON	ON	ON	ON

Fig. 1: Test Circuit

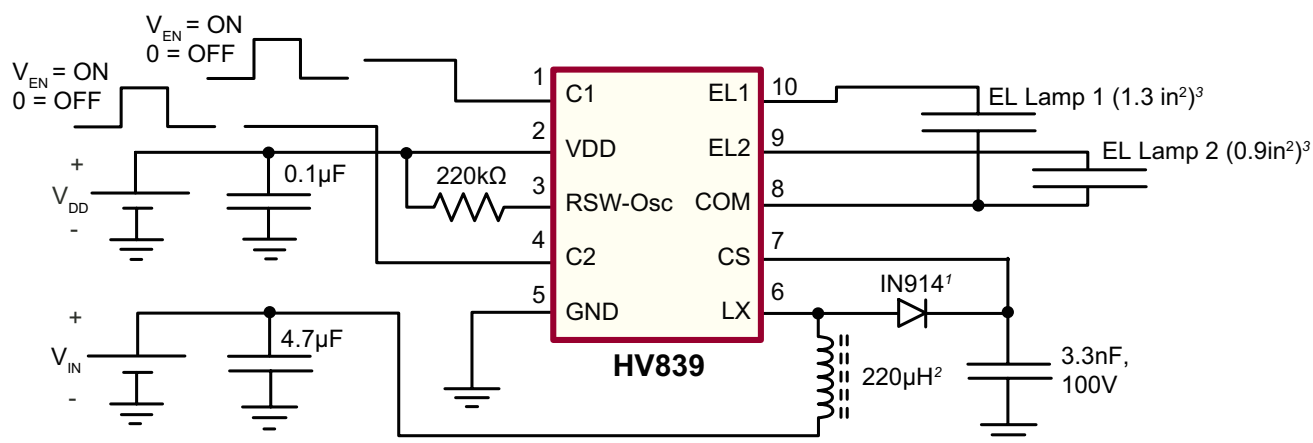

1. or any (equivalent or better) > 90V, fast recovery diode
2. Murata LQH32CN221K21
3. The bigger sized lamp should be tied to EL1 and the smaller sized lamp to EL2 terminals (pins 10 and 9 respectively)

Device	Lamp	V _{IN} = V _{DD}	I _{IN}	V _{CS}	f _{EL}	Brightness
HV839MG-G or HV839K6-G	EL1	3.0V	29.6mA	85.8	500Hz	13.68ft-lm
	Both EL1 and EL2 ON		45.0mA	76.2		12.66ft-lm

Split Supply Configuration

The HV839 can be used in applications operating from a battery where a regulated voltage is available. This is shown in Fig. 2. The regulated voltage can be used to drive the internal logic of HV839. The amount of current used to drive

the internal logic is less than 190µA. Therefore, the regulated voltage could easily provide the current without being loaded down.

Fig. 2: Split Supply Configuration

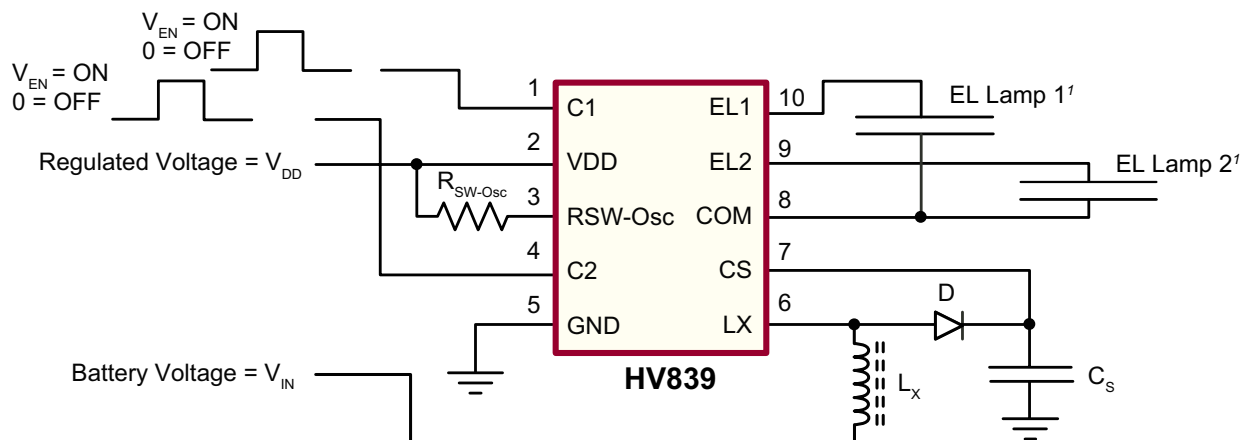

1. The bigger sized lamp should be tied to EL1 and the smaller sized lamp to EL2 terminals (pins 10 and 9 respectively)

Audible Noise Reduction

This section describes a method (patented) developed at Supertex to reduce the audible noise emitted by the EL lamps used in application sensitive to audible noise. The waveform takes the shape of approximately 2RC time constants for rising and 2RC time constants for falling, where C is the capacitance of the EL lamp, and R is the external resistor, R_{SER} connected in series with the EL lamp.

Fig. 3 shows a general circuit schematic that uses the series resistors, R_{SER1} and R_{SER2} , for each of the EL lamps. R_{SER1} and R_{SER2} are connected in series with the EL lamp. The audible noise can be set a desirable level by selecting the resistances for R_{SER1} and R_{SER2} . It is important to note that addition of these external resistors will reduce the voltage across the EL lamp, and hence the brightness of the EL lamp.

Fig. 3: Typical Application Circuit For Audible Noise Reduction

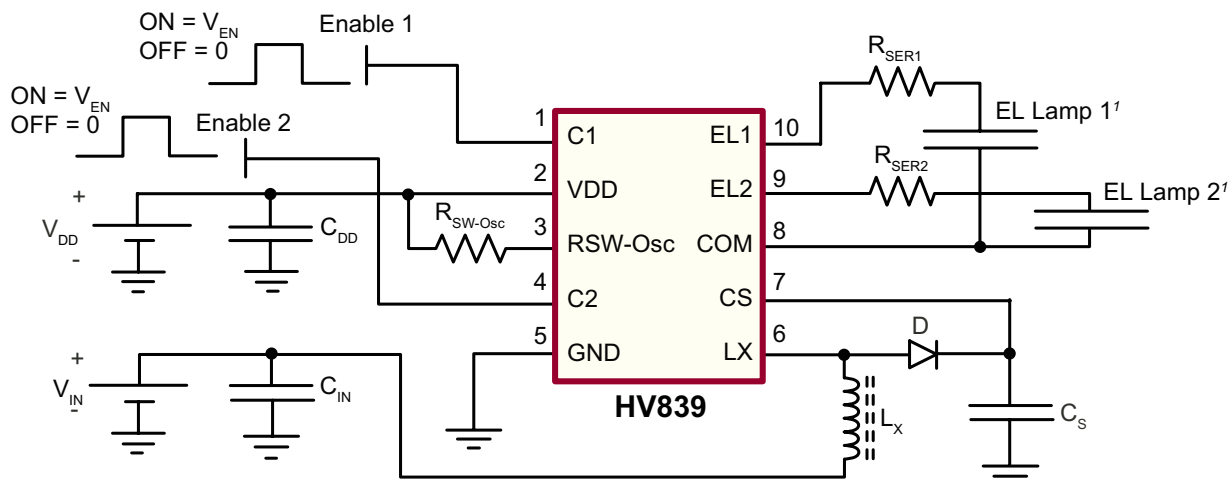

1. The bigger sized lamp should be tied to EL1 and the smaller sized lamp to EL2 terminals (pins 10 and 9 respectively)

Typical Performance Curves

(EL1 Lamp = 1.3in², EL2 Lamp = 0.93in², V_{DD} = 3.0V)

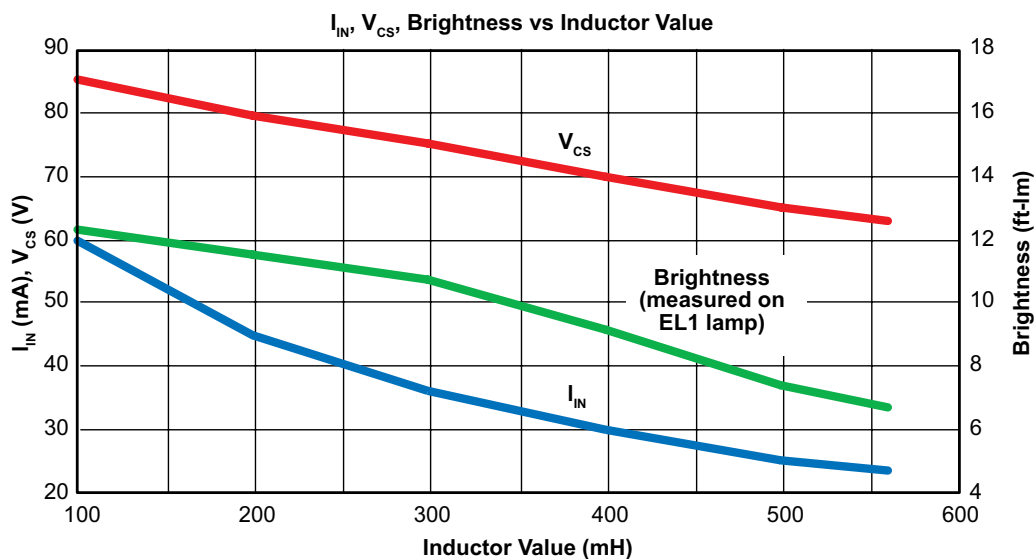
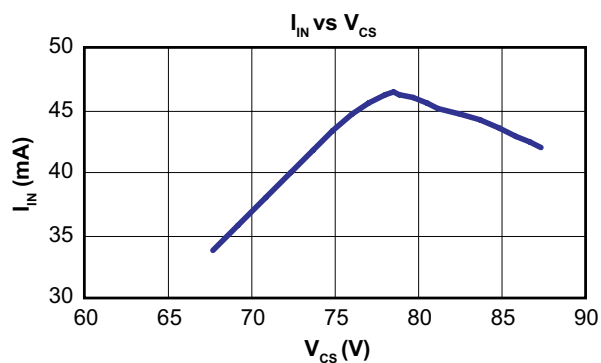
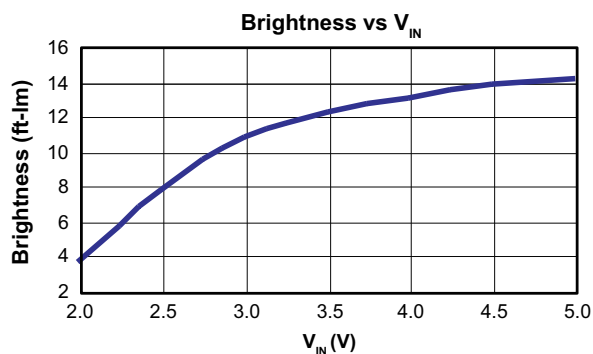
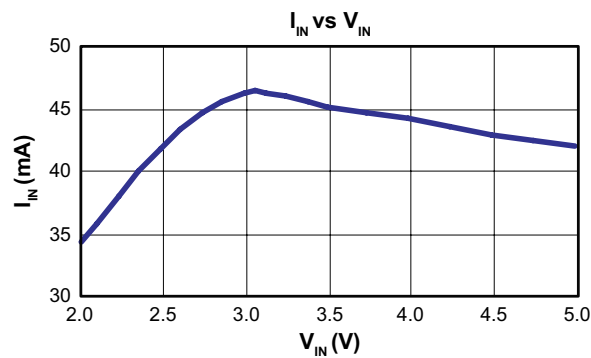
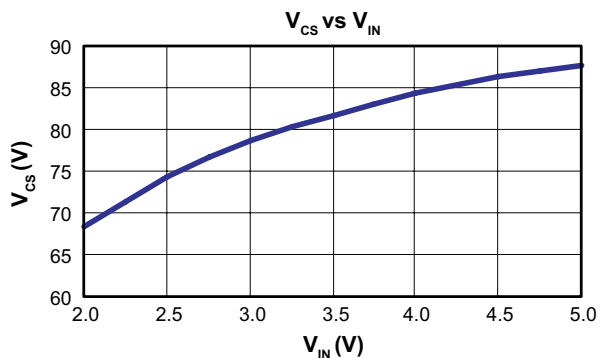

Pin Description

Pin #	Name	Function
1	C1	Enable input signal for EL lamp 1. Logic high will turn ON the EL lamp 1 and logic low will turn it OFF. Refer to the Function Table.
2	VDD	Input supply voltage pin.
3	RSW-Osc	<p>External resistor connection to set both the switching MOSFET frequency and EL Lamp frequency. The external resistor should be connected between this pin and the VDD pin. The EL lamp frequency is switching frequency divided by 128.</p> <p>The switching frequency increases as the value of R_{SW-OSC} decreases. A 220kΩ resistor will provide a switching frequency of 64.0kHz, and an EL lamp frequency of 500Hz. To change the frequency to f_{EL1}, the value of the resistor $R_{SW-OSC1}$ can be determined as:</p> $R_{SW-OSC1} = (220 \times 500) / f_{EL1} \text{ k}\Omega.$
4	C2	Enable input signal for EL lamp 2. Logic high will turn ON the EL lamp 2 and logic low will turn it OFF. Refer to the Function Table.
5	GND	IC Ground Pin.
6	LX	<p>External inductor connection to boost the low input voltage using inductive flyback. Connect an inductor between VIN and this pin. Also connect a high voltage fast recovery diode between this pin and the CS pin. The anode of the diode needs to be connected to the LX pin and the cathode to the CS pin. In general, small valued inductors, which can handle more current, are more suitable for driving large sized lamps. As the inductor value decreases, the switching frequency should be increased to avoid saturation.</p> <p>When the switching MOSFET is turned ON, the inductor is being charged. When the MOSFET is turned OFF, the energy stored in the inductor is transferred to the high voltage capacitor connected at the CS pin.</p>
7	CS	Connect a 100V capacitor between this pin and GND. This capacitor stores the energy transferred from the inductor.
8	COM	Common connection for both EL lamps. Connect one end of both the lamps to this pin.
9	EL2	EL lamp 2 connection. For optimum performance, the smaller of the two lamps should be connected to this pin.
10	EL1	EL lamp 1 connection. For optimum performance, the larger of the two lamps should be connected to this pin.

10-Lead DFN Package Outline (K6)

3.00x3.00mm body, 1.00mm height (max), 0.50mm pitch

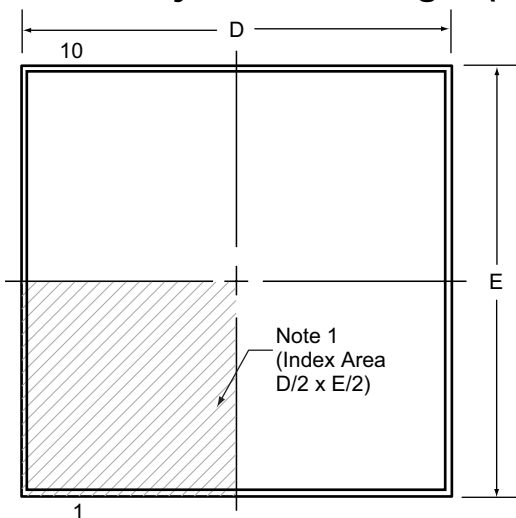

Top View

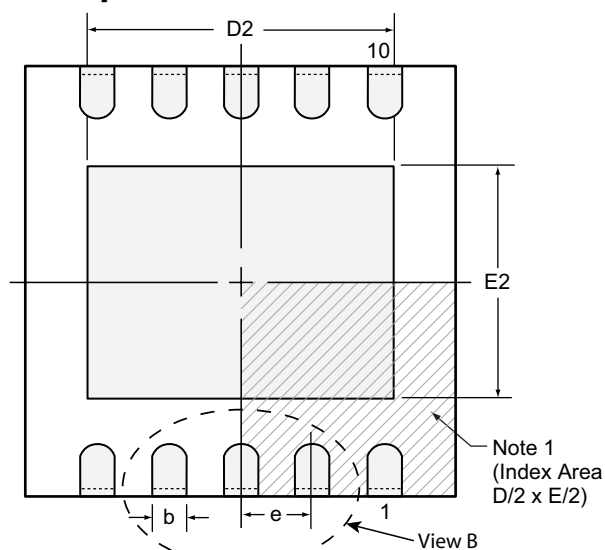

Bottom View

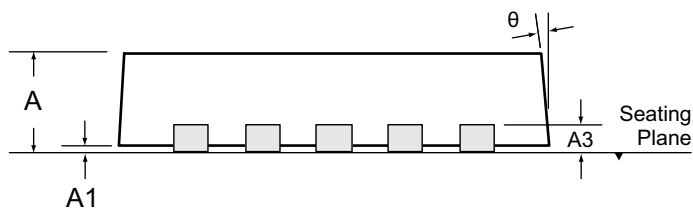

Side View

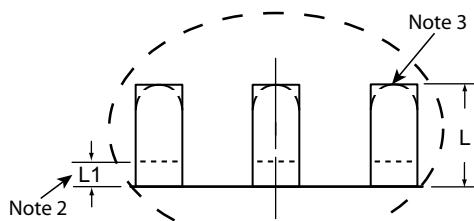

View B

Notes:

1. A Pin 1 identifier must be located in the index area indicated. The Pin 1 identifier can be: a molded mark/identifier; an embedded metal marker; or a printed indicator.
2. Depending on the method of manufacturing, a maximum of 0.15mm pullback (L1) may be present.
3. The inner tip of the lead may be either rounded or square.

Symbol	A	A1	A3	b	D	D2	E	E2	e	L	L1	θ	
Dimension (mm)	MIN	0.80	0.00	0.20 REF	0.18	2.85*	2.20	2.85*	1.40	0.50 BSC	0.30	0.00*	0°
	NOM	0.90	0.02		0.25	3.00	-	3.00	-		0.40	-	-
	MAX	1.00	0.05		0.30	3.15*	2.70	3.15*	1.75		0.50	0.15	14°

JEDEC Registration MO-229, Variation VEED-5, Issue C, Aug. 2003.

* This dimension is not specified in the JEDEC drawing.

Drawings not to scale.

Supertex Doc. #: DSPD-10DFNK63X3P050, Version B041309.

10-Lead MSOP Package Outline (MG)

3.00x3.00mm body, 1.10mm height (max), 0.50mm pitch

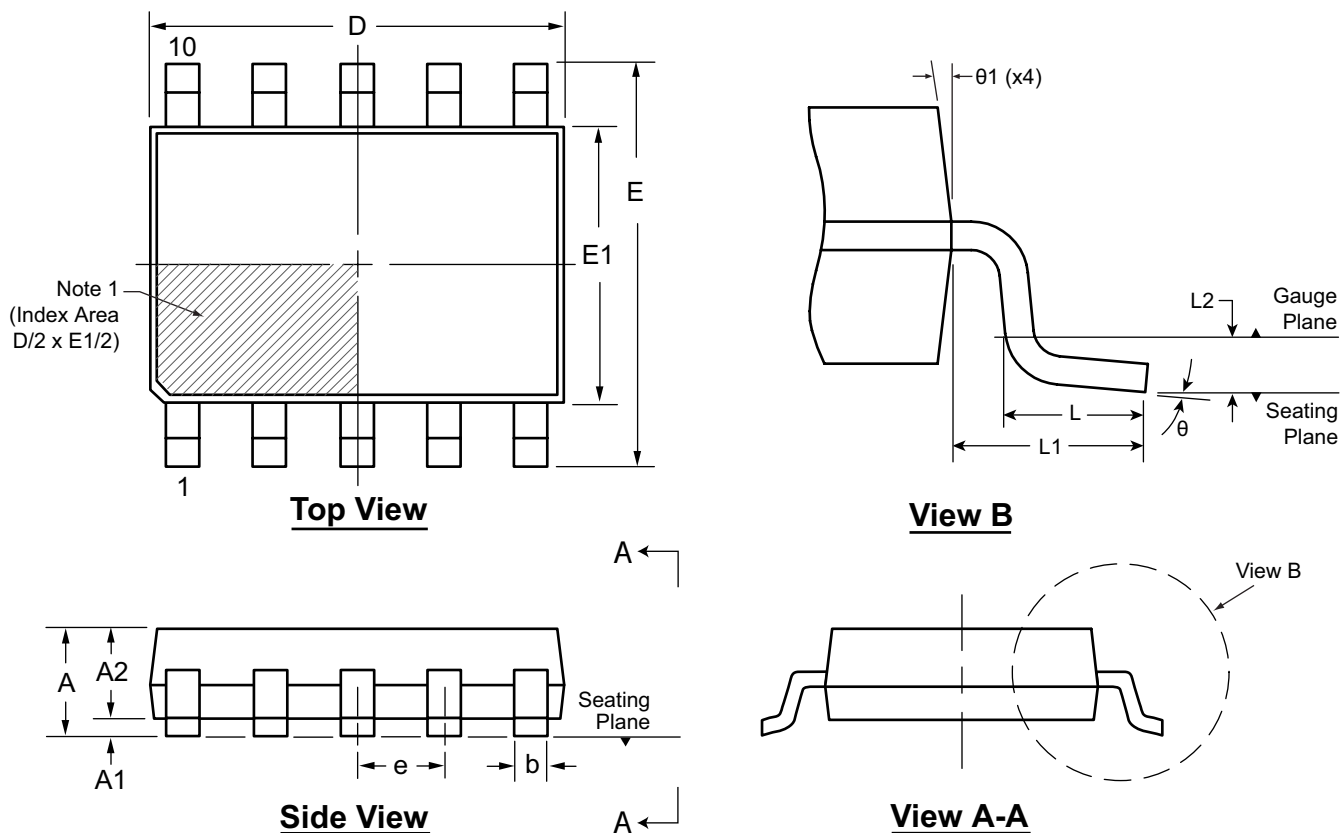

Note:
 1. A Pin 1 identifier must be located in the index area indicated. The Pin 1 identifier can be: a molded mark/identifier; an embedded metal marker; or a printed indicator.

Symbol	A	A1	A2	b	D	E	E1	e	L	L1	L2	θ	$\theta1$	
Dimension (mm)	MIN	0.75*	0.00	0.75	0.17	2.80*	4.65*	2.80*	0.50 BSC	0.40	0.95 REF	0.25 BSC	0°	5°
	NOM	-	-	0.85	-	3.00	4.90	3.00		0.60			-	-
	MAX	1.10	0.15	0.95	0.33	3.20*	5.15*	3.20*		0.80			8°	15°

JEDEC Registration MO-187, Variation BA, Issue E, Dec. 2004.

* This dimension is not specified in the JEDEC drawing.

Drawings are not to scale.

Supertex Doc. #: DSPD-10MSOPMG, Version F041309

(The package drawing(s) in this data sheet may not reflect the most current specifications. For the latest package outline information go to <http://www.supertex.com/packaging.html>.)

Supertex inc. does not recommend the use of its products in life support applications, and will not knowingly sell them for use in such applications unless it receives an adequate "product liability indemnification insurance agreement." Supertex inc. does not assume responsibility for use of devices described, and limits its liability to the replacement of the devices determined defective due to workmanship. No responsibility is assumed for possible omissions and inaccuracies. Circuitry and specifications are subject to change without notice. For the latest product specifications refer to the Supertex inc. (website: <http://www.supertex.com>)

X-ON Electronics

Largest Supplier of Electrical and Electronic Components

Click to view similar products for [Display Drivers & Controllers](#) category:

Click to view products by [Microchip](#) manufacturer:

Other Similar products are found below :

[ICB2FL01G](#) [HV5812PJ-G-M904](#) [TW8813-LB2-GR](#) [TW8811-PC2-GR](#) [MAX1839EEP+](#) [TW9907-TA1-GR](#) [LX27901IDW](#) [SSD2828QN4](#)
[ICB2FL01GXUMA2](#) [DLP2000FQC](#) [PAD1000YFFR](#) [S1D13746F01A600](#) [FIN324CMLX](#) [AD8387JSVZ](#) [DLPC6421ZPC](#) [HV852K7-G](#)
[HV859K7-G](#) [HV857K7-G](#) [DIO2133CT14](#) [S1D13506F00A200](#) [S1D13L03F00A100-40](#) [TW2836-BA1-GR](#) [SSD2829QL9](#) [MAX749CSA+T](#)
[MAX4820EUP+T](#) [ICL7135CAI+](#) [ICL7135CMH+D](#) [ICL7137CMH+D](#) [MAX25221BATJ/V+](#) [S1D13748B00B100](#) [S1D13A05B00B200](#)
[MAX3738ETG+T](#) [MAX8722CEEG+](#) [MAX749CPA+](#) [MAX8785AETI+](#) [ICL7135CQI+](#) [HV518PJ-G-M903](#) [HV5812P-G](#) [HV5812PJ-G](#)
[HV7224PG-G](#) [HV853K7-G](#) [HV860K7-G](#) [HV6810WG-G](#) [HV823LG-G](#) [HV857MG-G](#) [HV833MG-G](#) [HV857LMG-G](#) [HV859MG-G](#)
[FMS6363ACSX](#) [FMS6364AMTC14X](#)