

## High Voltage, Low Noise, Inductorless EL Lamp Driver

### Features

- ▶ No external components required when using an external EL clock frequency
- ▶ Audible noise reduction with improved EMI
- ▶ EL frequency can be set by an external resistor
- ▶ DC to AC converter
- ▶ Drives up to 5.3nF (approx. 1.5in<sup>2</sup> lamp) load
- ▶ Output voltage regulation
- ▶ Enable function
- ▶ EL Lamp dimming
- ▶ Available in 10-Lead DFN and 8-Lead MSOP packages

### Applications

- ▶ Cellular phone keypad
- ▶ Watches
- ▶ Small handheld wireless devices
- ▶ MP3 Players

### General Description

The Supertex HV853 is a high voltage, low noise EL (electroluminescent) lamp driver. It is the low noise version of the HV852 with improved EMI performance, operating over an input voltage range of 3.2V to 5.0V. It is designed to drive EL lamps of up to 1.5in<sup>2</sup>, with capacitive values up to 5.3nF. The HV853 converts a low voltage DC input to a high voltage AC output across an EL lamp. A nominal regulated output voltage of  $\pm 80V$  is applied to the EL lamp. It uses a charge pump scheme to boost the input voltage eliminating the need for an external inductor, diode, and high voltage capacitor commonly found in conventional topologies.

The charge pump circuit discharges its energy into an EL lamp through a high voltage H-bridge. Once the voltage reaches its regulated limit, it is turned off to conserve power. The EL lamp is then discharged to ground and the H-bridge changes state to allow the charge pump to charge the EL lamp in the opposite direction.

The EL lamp frequency can be set either by an external resistor  $R_{EL}$  or by applying an external clock where the clock frequency is divided by 128 to set the EL lamp frequency.

### Typical Application Circuits

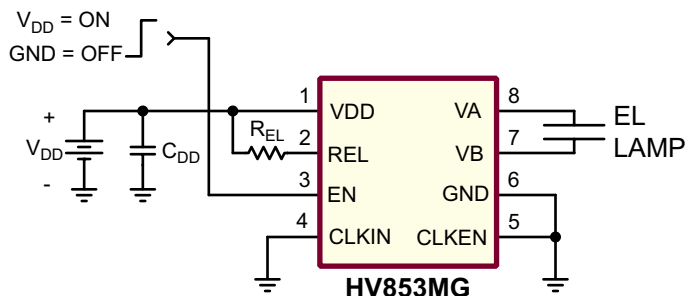

EL Lamp Frequency set by  $R_{EL}$

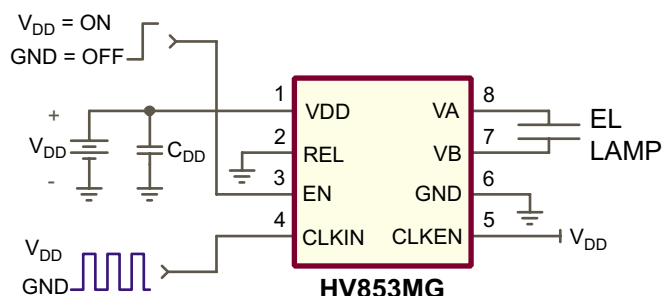

EL Lamp Frequency set by External Clock

## Ordering Information

DEVICE	Package Options	
	10-Lead DFN 3.00x3.00mm body 0.80mm height (max) 0.50mm pitch	8-Lead MSOP 3.00x3.00mm body 1.10mm height (max) 0.65mm pitch
HV853	HV853K7-G	HV853MG-G

-G indicates package is RoHS compliant ("Green")



## Absolute Maximum Ratings

Parameter	Value
V <sub>DD</sub> , supply voltage	-0.5V to 6.5V
Storage temperature	-65°C to +150°C
Power dissipation (10-Lead DFN)	1.6W
Power dissipation (8-Lead MSOP)	300mW

Absolute Maximum Ratings are those values beyond which damage to the device may occur. Functional operation under these conditions is not implied. Continuous operation of the device at the absolute rating level may affect device reliability. All voltages are referenced to device ground.

## Pin Configurations

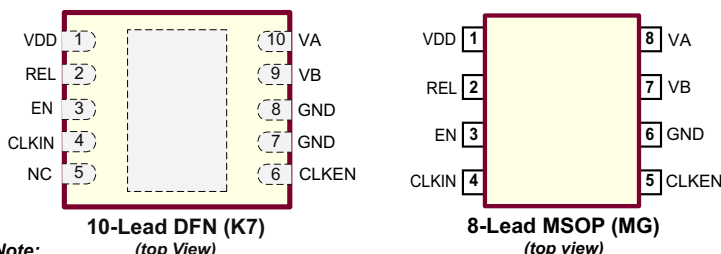

Note:  
Pads are at the bottom of the package.  
Center heat slug should be connected to GND or left floating.

## Product Marking

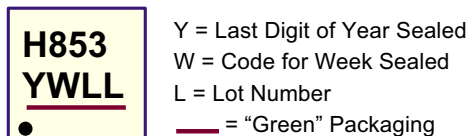

### 10-Lead DFN (K7)

Top Marking

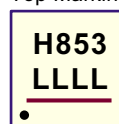

Bottom Marking

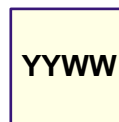

### 8-Lead MSOP(MG)

## Recommended Operating Conditions

Sym	Parameter	Min	Typ	Max	Units	Conditions
V <sub>DD</sub>	Input voltage	3.2	-	5.0	V	---
f <sub>EL</sub>	EL lamp frequency	50	-	500	Hz	---
C <sub>load</sub>	EL lamp capacitance	0	-	5.3	nF	---
T <sub>A</sub>	Operating temperature	-25	-	+85	°C	---

## Electrical Characteristics

(Over recommended operating conditions unless otherwise specified, T<sub>A</sub> = 25°C)

Sym	Parameter	Min	Typ	Max	Units	Conditions
I <sub>DDQ</sub>	Quiescent current	-	-	150	nA	EN = 0V
V <sub>A</sub> or V <sub>B</sub>	Peak output voltage	68	80	92	V	No load
V <sub>A</sub> -V <sub>B</sub>	Peak to peak output voltage	136	160	184	V	
I <sub>DD</sub>	Operating current	-	15	30	mA	See Figure 1 V <sub>DD</sub> = 3.5V R <sub>EL</sub> = 1.5MΩ Load = 3.3nF + 1.0kΩ
V <sub>A</sub> or V <sub>B</sub>	Peak output voltage	68	80	92	V	
V <sub>A</sub> -V <sub>B</sub>	Peak to peak output voltage	136	160	184	V	
f <sub>EL</sub>	EL lamp frequency	240	280	320	Hz	

## Electrical Characteristics (cont.)

(Over recommended operating conditions unless otherwise specified,  $T_A = 25^\circ\text{C}$ )

Sym	Parameter	Min	Typ	Max	Units	Conditions
$t_{\text{rout}}$	Output voltage rise time	-	450	-	$\mu\text{s}$	1.0in <sup>2</sup> lamp 0V to 90% of final value
$t_{\text{fout}}$	Output voltage fall time	150	-	-	$\mu\text{s}$	90% to 10% of final value

### Logic Inputs

Sym	Parameter	Min	Typ	Max	Units	Conditions
$V_{\text{IL}}$	Input logic low voltage	0	-	0.5	V	---
$V_{\text{IH}}$	Input logic high voltage	2.0	-	$V_{\text{DD}}$	V	---
$I_{\text{IL}}$	Input logic low current	-	-	1.0	$\mu\text{A}$	---
$I_{\text{IH}}$	Input logic high current	-	-	1.0	$\mu\text{A}$	---
$EN_{\text{rise}}$	Enable input rise time (for delay turn off)	0.01	-	10	ms	Using external R-C circuit, see Figure 2
$EN_{\text{fall}}$	Enable input fall time (for delay turn off)	10 $\mu$	-	5.0	s	
$C_{\text{in}}$	Logic input capacitance	-	-	10	pF	---

## Typical Output Waveform

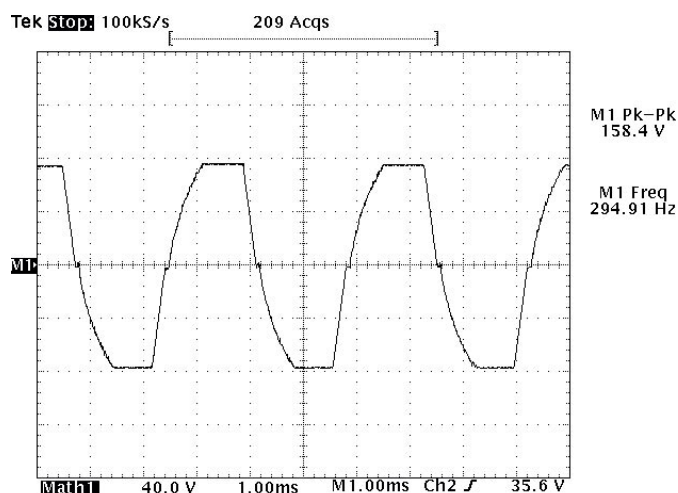

## Functional Block Diagram

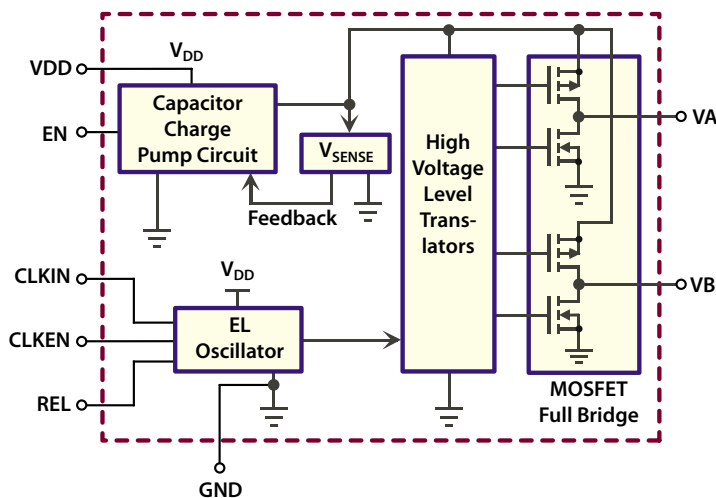

### Typical Performance

(The following was the observed performance when driving a 1.0in<sup>2</sup> green lamp)

Load	R <sub>EL</sub> (MΩ)	V <sub>DD</sub> (V)	I <sub>DD</sub> (mA)	V <sub>A</sub> -V <sub>B</sub> (V)	f <sub>EL</sub> (Hz)
3.3nF + 1.0kΩ	1.5	3.2	13.1	158	294
		3.5	12.9	158	
		3.8	12.7	158	
		4.2	12.5	158	
		5.0	12.3	158	

Figure 1: Typical Application

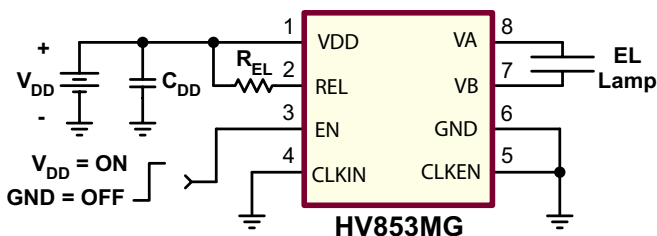

Figure 2: Push Button Turn on with Delay Turn off

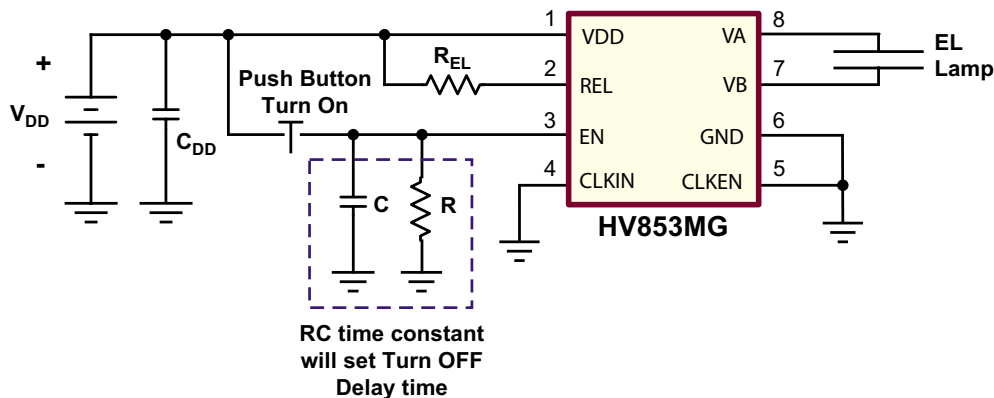
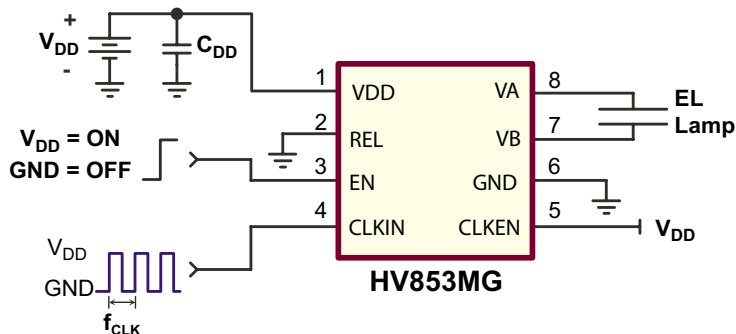

Figure 3: Independent Programmable Output Frequency (f<sub>EL</sub>)



Note: f<sub>EL</sub> = f<sub>CLK</sub>/128

## EL Lamp Dimming Using PWM

EL lamp dimming can be achieved by applying a PWM signal to the ENABLE pin. This is done by pulse skipping the output pulses. The PWM frequency should be kept below the EL frequency but above 50Hz to avoid flickering.

**Figure 4: PWM Dimming Circuit**

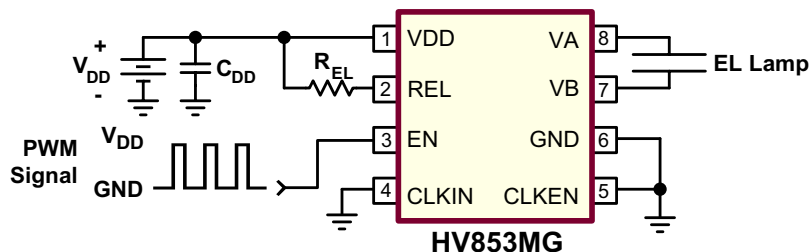

## Pin Descriptions: 10-Lead DFN (K7) / 8-Lead MSOP (MG)

K7	MG	Pin Name	Description
Pin #			
1	1	VDD	Input supply voltage pin.
2	2	REL	An external resistor to VDD will set the EL lamp frequency. The EL frequency is inversely proportional to the $R_{EL}$ resistor value. A 1.5M $\Omega$ resistor would provide a nominal lamp frequency of 280Hz $f_{EL} = (1.5M\Omega)(280Hz) / (R_{EL})$ When using an external clock to set the EL lamp frequency, the REL pin should be connected to ground.
3	3	EN	Enable input pin. Logic high will turn the device on. An external R-C circuit can be added for a delayed turn off.
4	4	CLKIN	Logic input pin. An external logic clock applied to this pin can be used to set the EL lamp frequency (see Figure 3). The EL lamp frequency is the external clock frequency divided by 128. This is useful for applications requiring the EL lamp to be synchronized to a system clock. Connect to ground when not in use.
5	-	NC	No connect.
6	5	CLKEN	Logic input pin. Logic high will cause the EL lamp frequency to be set by the CLKIN input. Logic low will cause the EL lamp frequency to be set by the external $R_{EL}$ resistor.
7,8	6	GND	IC ground pin.
9	7	VB	EL lamp driver output pin. The EL lamp is connected across VA and VB terminals.
10	8	VA	EL lamp driver output pin. The EL lamp is connected across VA and VB terminals.

# 10-Lead DFN Package Outline (K7)

3.00x3.00mm body, 0.80mm height (max), 0.50mm pitch

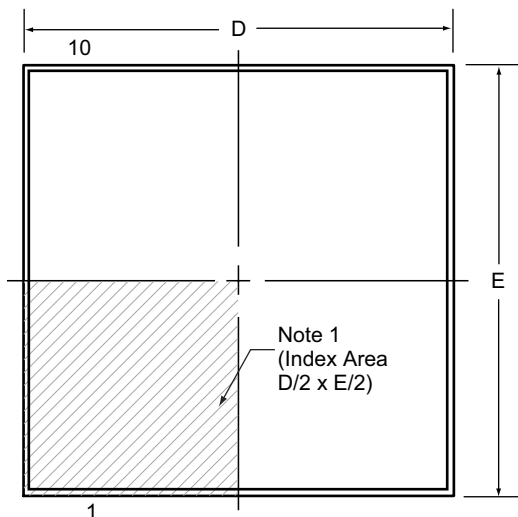

**Top View**

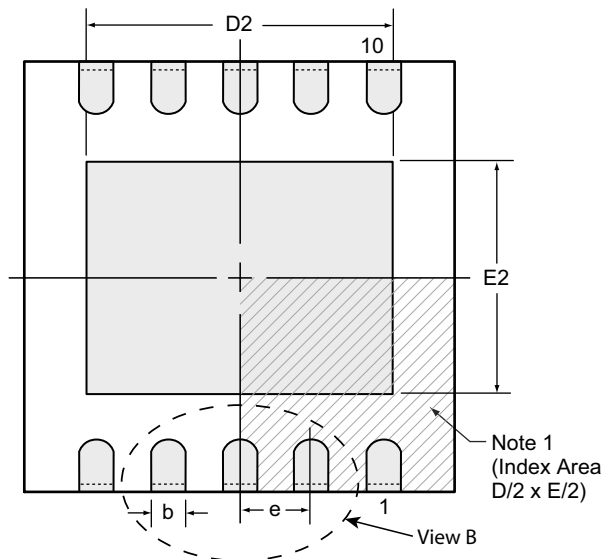

**Bottom View**

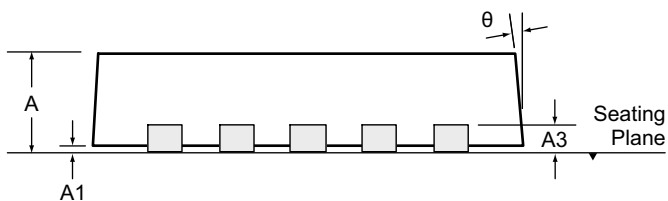

**Side View**

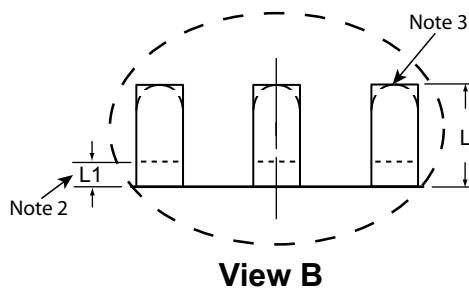

**View B**

**Notes:**

1. A Pin 1 identifier must be located in the index area indicated. The Pin 1 identifier can be: a molded mark/identifier; an embedded metal marker; or a printed indicator.
2. Depending on the method of manufacturing, a maximum of 0.15mm pullback (L1) may be present.
3. The inner tip of the lead may be either rounded or square.

Symbol	A	A1	A3	b	D	D2	E	E2	e	L	L1	θ	
Dimension (mm)	MIN	0.70	0.00	0.20 REF	0.18	2.85*	2.20	2.85*	1.40	0.50 BSC	0.30	0.00*	0°
	NOM	0.75	0.02		0.25	3.00	-	3.00	-		0.40	-	-
	MAX	0.80	0.05		0.30	3.15*	2.70	3.15*	1.75		0.50	0.15	14°

JEDEC Registration MO-229, Variation WEED-5, Issue C, Aug. 2003.

\* This dimension is not specified in the original JEDEC drawing. The value listed is for reference only.

Drawings not to scale.

Supertex Doc.#: DSPD-10DFNK73X3P050, Version C101008.

# 8-Lead MSOP Package Outline (MG)

3.00x3.00mm body, 1.10mm height (max), 0.65mm pitch

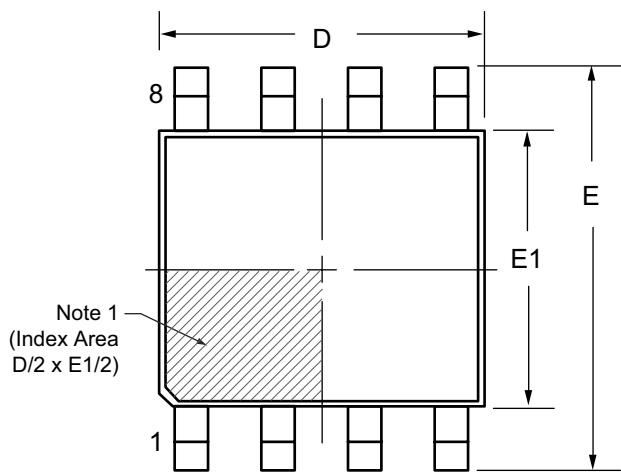

**Top View**

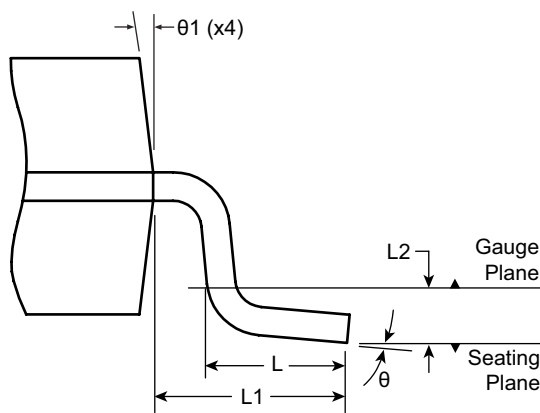

**View B**

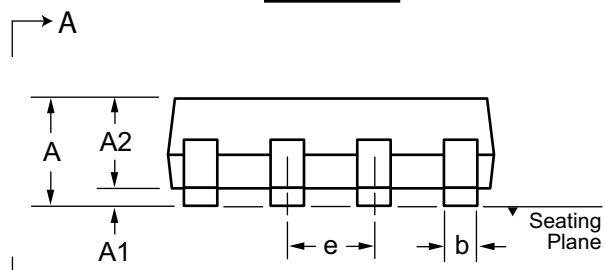

**Side View**

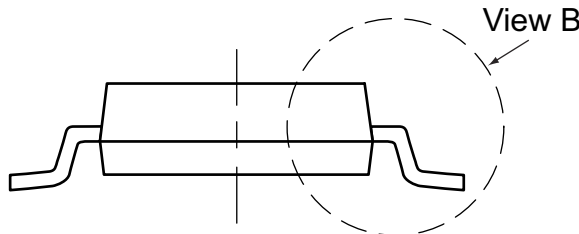

**View A-A**

**Note:**  
 1. A Pin 1 identifier must be located in the index area indicated. The Pin 1 identifier can be: a molded mark/identifier; an embedded metal marker; or a printed indicator.

Symbol	A	A1	A2	b	D	E	E1	e	L	L1	L2	$\theta$	$\theta 1$	
Dimension (mm)	MIN	0.75*	0.00	0.75	0.22	2.80*	4.65*	2.80*	0.65 BSC	0.40	0.95 REF	0.25 BSC	0°	5°
	NOM	-	-	0.85	-	3.00	4.90	3.00		0.60			-	-
	MAX	1.10	0.15	0.95	0.38	3.20*	5.15*	3.20*		0.80			8°	15°

JEDEC Registration MO-187, Variation AA, Issue E, Dec. 2004.  
 \* This dimension is not specified in the original JEDEC drawing. The value listed is for reference only.  
**Drawings are not to scale.**  
**Supertex Doc. #: DSPD-8MSOPMG, Version G101008.**

(The package drawing(s) in this data sheet may not reflect the most current specifications. For the latest package outline information go to <http://www.supertex.com/packaging.html>.)

Supertex inc. does not recommend the use of its products in life support applications, and will not knowingly sell them for use in such applications unless it receives an adequate "product liability indemnification insurance agreement." Supertex inc. does not assume responsibility for use of devices described, and limits its liability to the replacement of the devices determined defective due to workmanship. No responsibility is assumed for possible omissions and inaccuracies. Circuitry and specifications are subject to change without notice. For the latest product specifications refer to the Supertex inc. website: <http://www.supertex.com>.

## X-ON Electronics

Largest Supplier of Electrical and Electronic Components

*Click to view similar products for [Display Drivers & Controllers](#) category:*

*Click to view products by [Microchip](#) manufacturer:*

Other Similar products are found below :

[ICB2FL01G](#) [HV5812PJ-G-M904](#) [TW8813-LB2-GR](#) [TW8811-PC2-GR](#) [MAX1839EEP+](#) [TW9907-TA1-GR](#) [LX27901IDW](#) [SSD2828QN4](#)  
[ICB2FL01GXUMA2](#) [DLP2000FQC](#) [PAD1000YFFR](#) [S1D13746F01A600](#) [FIN324CMLX](#) [AD8387JSVZ](#) [DLPC6421ZPC](#) [HV852K7-G](#)  
[HV859K7-G](#) [HV857K7-G](#) [DIO2133CT14](#) [S1D13506F00A200](#) [S1D13L03F00A100-40](#) [TW2836-BA1-GR](#) [SSD2829QL9](#) [MAX749CSA+T](#)  
[MAX4820EUP+T](#) [ICL7135CAI+](#) [ICL7135CMH+D](#) [ICL7137CMH+D](#) [MAX25221BATJ/V+](#) [S1D13748B00B100](#) [S1D13A05B00B200](#)  
[MAX3738ETG+T](#) [MAX8722CEEG+](#) [MAX749CPA+](#) [MAX8785AETI+](#) [ICL7135CQI+](#) [HV518PJ-G-M903](#) [HV5812P-G](#) [HV5812PJ-G](#)  
[HV7224PG-G](#) [HV853K7-G](#) [HV860K7-G](#) [HV6810WG-G](#) [HV823LG-G](#) [HV857MG-G](#) [HV833MG-G](#) [HV857LMG-G](#) [HV859MG-G](#)  
[FMS6363ACSX](#) [FMS6364AMTC14X](#)