

High Voltage Tri-EL Lamp Driver IC

Features

- ▶ High voltage, Tri-EL lamp driver with common terminal
- ▶ Independent brightness control for all three lamps
- ▶ 210V_{pp} output voltage for higher brightness
- ▶ 1.8 to 6.5V operating supply voltage
- ▶ Output voltage regulation
- ▶ Two-pin serial data communication for control
- ▶ Linear brightness control with seven steps at constant efficiency
- ▶ 128kHz fixed switching frequency
- ▶ Split supply capability
- ▶ Patented high efficiency EL lamp driver
- ▶ Single miniature inductor drives all three lamps
- ▶ Only four external components
- ▶ Burst mode power converter for best efficiency
- ▶ CMOS compatible serial interface with noise rejection
- ▶ 150nA max. leakage current when disabled
- ▶ Power-on reset causes all outputs to be off when first powered up
- ▶ Available in 10-Lead DFN package (0.8mm thickness)

Applications

- ▶ Multi-segment, variable displays
- ▶ Cell phone keypads and displays
- ▶ MP3 players

General Description

The Supertex HV856 is a high voltage, triple EL lamp driver designed for driving combined EL lamps of up to 3.0in² (1.0 in² each). It is a higher voltage version of the HV858. The input supply voltage range is from 1.8 to 6.5V. The device is designed so that the input voltage to the inductor can differ from the input voltage to the device (split supply). The device uses a single inductor and a minimum number of passive components. The nominal regulated output voltage that is applied to the EL lamp is ±105V. The HV856 has two internal oscillators; one for the internal switching MOSFET and the other for the high voltage EL lamp driver. The EL lamp frequency is fixed internally at 500Hz. The power converter oscillator runs 256 times faster than the EL lamp driver at 128kHz.

An external inductor is connected between the LX and VDD pins (or between the LX pin and separate voltage source in the case of a split supply application). A 0.002 - 0.01μF, 200V capacitor is connected between the CS pin and ground. The switching MOSFET charges the external inductor and discharges it into the capacitor at the CS pin. The voltage at CS will start to increase. Once the voltage at CS reaches a nominal value of 105V, the switching MOSFET is turned OFF to conserve power.

One side of the three EL lamps is connected to the COM pin of the HV856 and the other side to the EL1, EL2, and EL3 pins of the HV856. Each EL lamp output may be independently controlled to have one of the seven brightness levels or can be completely turned OFF by a 10-bit serial data input register. The 10-bit control code has three bits to control the brightness level of each EL lamp and one bit to optionally control the power converter. The 3-bit binary brightness control code controls the number of 500Hz cycles (from 0 to 7) in a group of seven cycles.

Typical Application Circuit

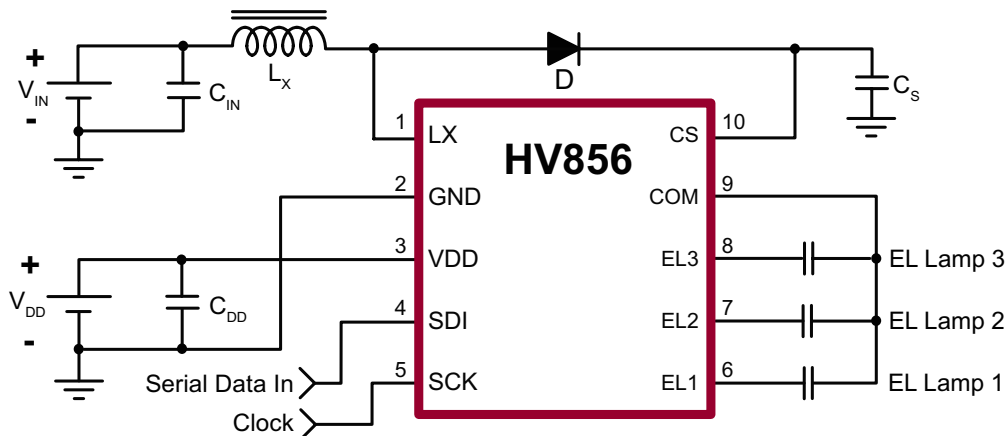

Ordering Information

Device	10-Lead DFN 3.00x3.00mm body 0.80mm height (max) 0.50mm pitch
HV856	HV856K7-G

-G indicates the package is RoHS compliant - "Green"



Absolute Maximum Ratings

Parameter	Value
V _{DD}	-0.5 to +7V
SDI, SDK	-0.5 to +7V
I _{SW}	0.7A peak
V _{CS}	0.5 to +120V
Power dissipation	1.6W
Storage temperature	-65°C to +150°C
Operating temperature	-40°C to +85°C

Absolute Maximum Ratings are those values beyond which damage to the device may occur. Functional operation under these conditions is not implied. Continuous operation of the device at the absolute rating level may affect device reliability. All voltages are referenced to device ground.

Pin Configuration

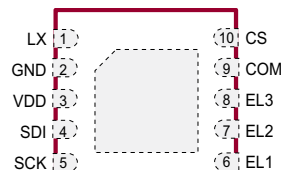

10-Lead DFN (K7)
(top view)

Note:

The pads are at the bottom of the package. The center heat slug is at ground potential.

Product Marking



Y = Last Digit of Year Sealed
W = Code for Week Sealed
L = Lot Number
• = "Green" Packaging

Package may or may not include the following marks: Si or

10-Lead DFN (K7)

Recommended Operating Conditions

Sym	Parameter	Min	Typ	Max	Unit	Conditions
V _{DD}	Supply voltage	1.8	-	6.5	V	---
I _{SW(pk)}	Peak switch current	-	-	0.4	A	---
T _A	Operating temperature	-40	-	85	°C	---

Electrical Specifications (unless otherwise specified, T_A = 25°C, V_{DD} = 2.6V to 5.5V)

Sym	Parameter	Min	Typ	Max	Unit	Conditions
R _{SW}	On-resistance of switching transistor	-	4.0	6.0	Ω	V _{DD} = 1.8 to 6.5V, I _{SW} = 100mA
V _{CS}	Output voltage	95	105	115	V	S1...S9 = 0, V _{DD} = 1.8 to 6.5V, no load
V _{LAMP}	Differential lamp voltage	190	210	230	V	V _{COM} to any EL, no load, code* = 111
I _{DD}	V _{DD} supply current	0.01	0.15	0.25	mA	V _{CS} = 20V, no load, PWR_ON = 1
I _{CS}	V _{CS} supply current	10	50	100	μA	V _{CS} = 75V, no load
I _{DDQ}	V _{DD} leakage current when disabled	-	100	150	nA	S1...S9 = 0, SCK and SDI can be tied to V _{DD} or GND
f _{SW}	Inductor switching frequency	108.8	128	147.2	kHz	See Fig.1
f _{EL}	Lamp frequency	425	500	575	Hz	For all codes except code* = 000
V _{LOW}	Logic pin input Low level	-0.5	0	0.2V _{DD}	V	---
V _{HIGH}	Logic pin input High level	0.8V _{DD}	V _{DD}	V _{DD} + 0.5	V	---

* Code refers to the 3-bit Brightness Control Code for the respective EL Lamp

Electrical Specifications (cont.)

Sym	Parameter	Min	Typ	Max	Units	Conditions
I _{LOGIC}	Logic pin input current	-0.1	0	0.1	μA	0 < V _{DD} < 7V
I _{IN}	Inductor current	-	60	70	mA	See Fig.1 V _{DD} = V _{IN} = 3V, total lamp size = 3.0in ² (1.0in ² each) 10-bit SDI serial code = 1111111111
V _{CS}	Output voltage	-	94.3	-	V	
f _{EL}	Lamp frequency	-	500	-	Hz	
D _{MAX}	Maximum PWM switch duty cycle	80	88	94	%	V _{CS} = 20V, R _{LOAD} = 20Ω
f _{CLK}	SCK speed	-	-	1.0	MHz	---
T _{SU}	SDI setup time before SCK rises	30	-	-	ns	---
T _H	SDI hold time before SCK rises	30	-	-	ns	---

Logic Input Conditions

The serial data input consists of a 10-bit string, three bits of brightness control and one bit (10th bit) to optionally control the power converter. The power converter runs if any of the EL lamps has a non-zero brightness value or if the PWR_ON bit is high while the other nine bits are low.

- SDI may be H or L if SCK is H.
- SCK may be H or L if SDI is H.
- While inputting serial data to the shift register, SDI can change value only when SCK is L.
- The previous ten bits of serial input will be latched when SDI makes L to H transition while SCK is H.

EL Lamp Brightness Control

The EL lamp brightness control is a 3-bit binary number stored in a latch, which is provided by a serial to parallel conversion shift register.

- If all the three bits for a designated EL lamp are L, the differential voltage across that lamp will be zero.
- If any of the three bits for a designated EL lamp is H:
 - The 3-bit value sets the average number of cycles for which the EL lamp voltage is non-zero.
 - The EL lamp brightness is linearly proportional to the binary lamp control code.

Logic Input Diagram

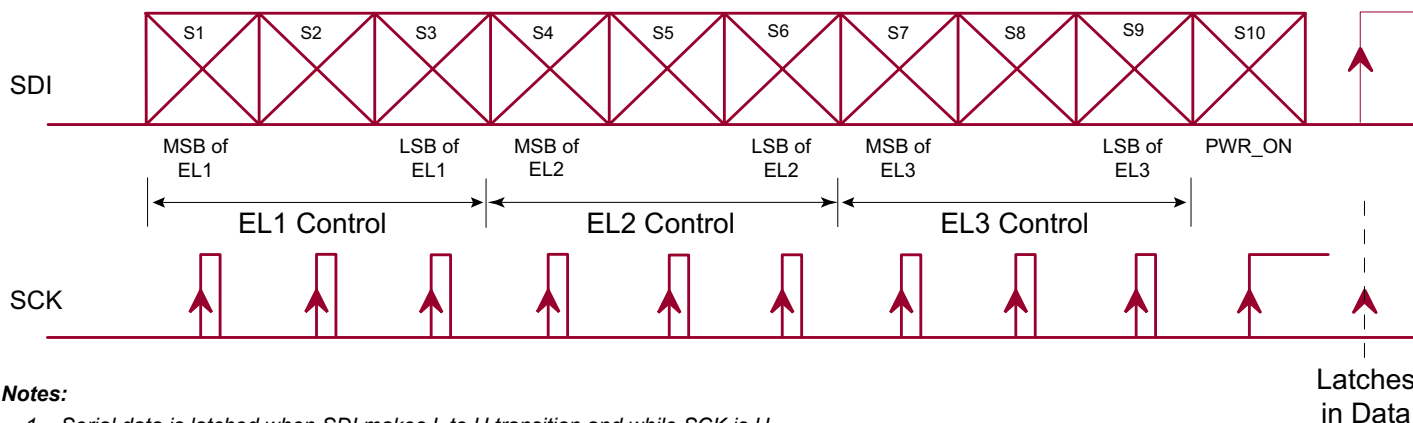

Notes:

- Serial data is latched when SDI makes L to H transition and while SCK is H.
- S1 is the first serial data input being fed.

Logic Truth Table

	Brightness Level	S1	S2	S3	S4	S5	S6	S7	S8	S9	S10
Device Disabled	All Lamps Off	L	L	L	L	L	L	L	L	L	L
Device Enabled		L	L	L	L	L	L	L	L	L	H
EL1	7/7	H	H	H	-	-	-	-	-	-	-
	6/7	H	H	L	-	-	-	-	-	-	-
	5/7	H	L	H	-	-	-	-	-	-	-
	4/7	H	L	L	-	-	-	-	-	-	-
	3/7	L	H	H	-	-	-	-	-	-	-
	2/7	L	H	L	-	-	-	-	-	-	-
	1/7	L	L	H	-	-	-	-	-	-	-
	OFF	L	L	L	-	-	-	-	-	-	-
EL2	7/7	-	-	-	H	H	H	-	-	-	-
	6/7	-	-	-	H	H	L	-	-	-	-
	5/7	-	-	-	H	L	H	-	-	-	-
	4/7	-	-	-	H	L	L	-	-	-	-
	3/7	-	-	-	L	H	H	-	-	-	-
	2/7	-	-	-	L	H	L	-	-	-	-
	1/7	-	-	-	L	L	H	-	-	-	-
	OFF	-	-	-	L	L	L	-	-	-	-
EL3	7/7	-	-	-	-	-	-	H	H	H	-
	6/7	-	-	-	-	-	-	H	H	L	-
	5/7	-	-	-	-	-	-	H	L	H	-
	4/7	-	-	-	-	-	-	H	L	L	-
	3/7	-	-	-	-	-	-	L	H	H	-
	2/7	-	-	-	-	-	-	L	H	L	-
	1/7	-	-	-	-	-	-	L	L	H	-
	OFF	-	-	-	-	-	-	L	L	L	-

L = Low (L = 0 to L < 20% of V_{DD})
H = High (80% of V_{DD} < H = V_{DD})
- = Does not control brightness of the designated EL lamp

Functional Block Diagram

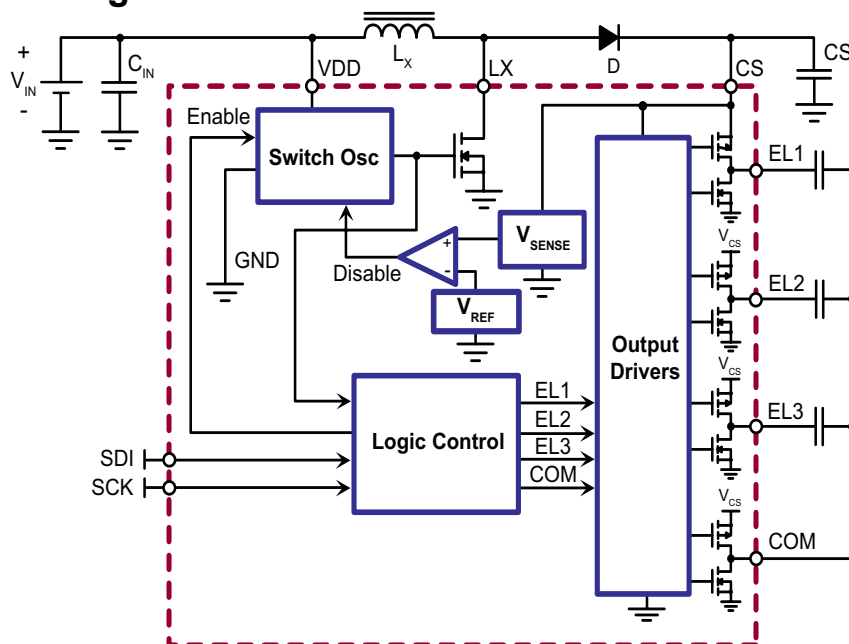

Note:
 This drawing is a generalized representation. Actual internal circuitry may differ.

Differential Output Waveform

The following is the differential output waveform across the lamp for each 3-bit input code for each lamp.

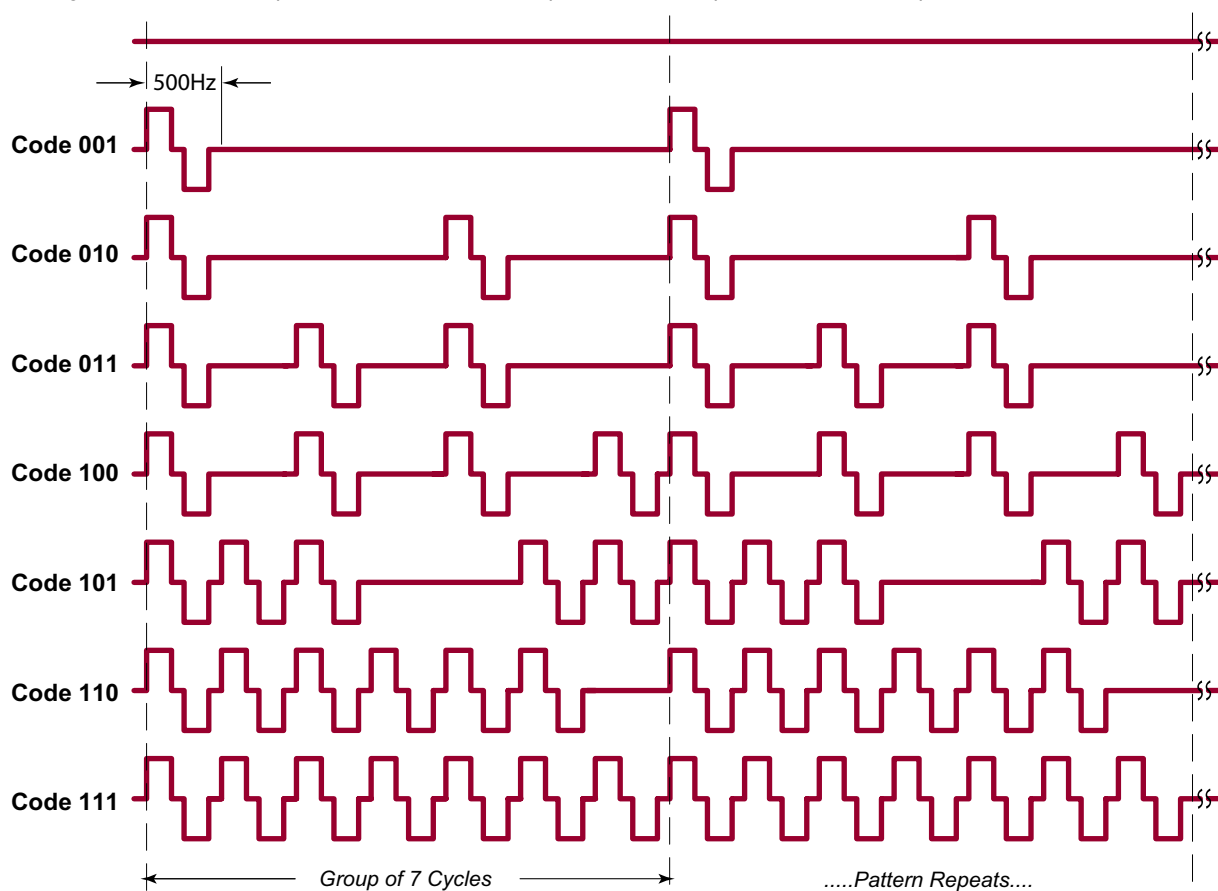

Test Circuit

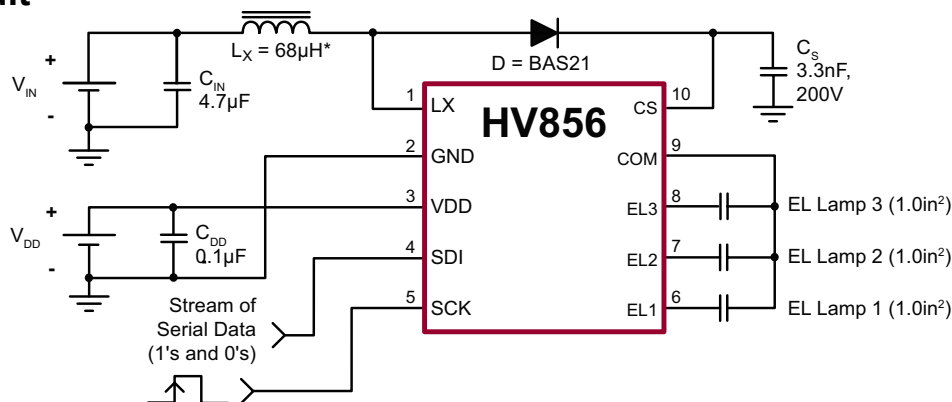

*Murata Inductor - LQH32CN680

Note:
Maximum lamp size for each segment is 1.0 in². To drive larger size lamps, any combination of EL1, EL2 and EL3 can be paralleled. However, the 3-bit serial data input code (for each output) should be such that the paralleled outputs have the same code.

Typical Performance ($V_{DD} = 3.0V, V_{IN} = 3.3V$)

1 ST 9-bit SDI Code	EL1 Brightness			I_{IN} (mA)	V_{CS} (V _{PEAK})
	Level	ft-lm	cd/m ²		
000111111	0/7	0	0	48.72	103
001111111	1/7	1.93	6.60	50.21	103
010111111	2/7	4.05	13.85	52.42	103
011111111	3/7	6.15	21.03	54.03	103
100111111	4/7	8.20	28.04	55.45	103
101111111	5/7	10.13	34.64	56.63	103
110111111	6/7	12.30	42.07	58.41	103
111111111	7/7	14.80	50.62	60.40	103

HV856 Pin Description

Pin	Name	Description
1	LX	Inductor pin
2	GND	Ground pin
3	VDD	Input voltage supply pin. (It is common practice to use a bypass capacitor as close as possible to the device on this pin)
4	SDI	Serial data input pin
5	SCK	Serial clock input pin
6	EL1	EL Lamp 1 pin
7	EL2	EL Lamp 2 pin
8	EL3	EL Lamp 3 pin
9	COM	Common pin for one side of all three EL lamps
10	CS	High voltage capacitor pin

10-Lead DFN Package Outline (K7)

3.00x3.00mm body, 0.80mm height (max), 0.50mm pitch

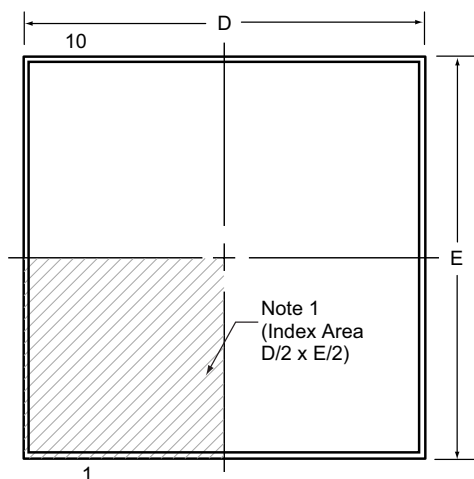

Top View

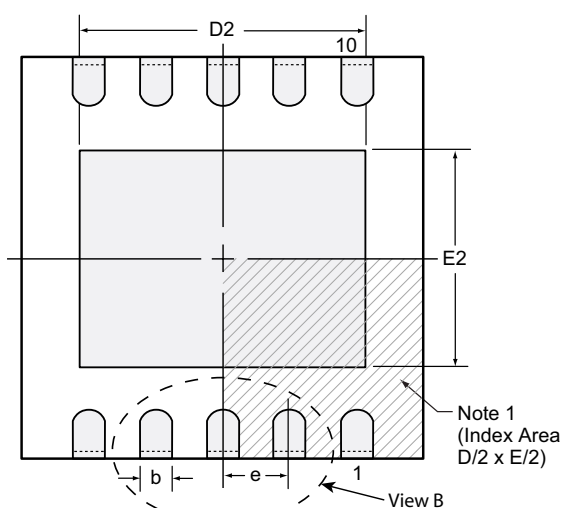

Bottom View

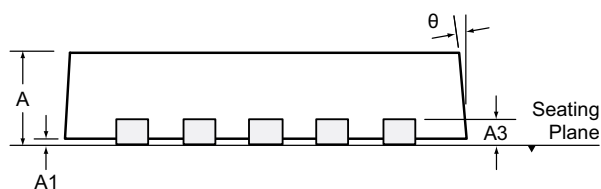

Side View

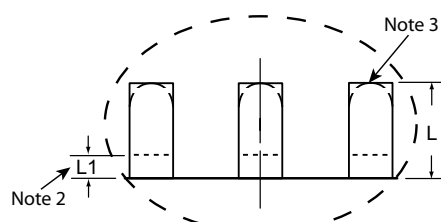

View B

Notes:

1. A Pin 1 identifier must be located in the index area indicated. The Pin 1 identifier can be: a molded mark/identifier; an embedded metal marker; or a printed indicator.
2. Depending on the method of manufacturing, a maximum of 0.15mm pullback (L1) may be present.
3. The inner tip of the lead may be either rounded or square.

Symbol	A	A1	A3	b	D	D2	E	E2	e	L	L1	θ	
Dimension (mm)	MIN	0.70	0.00	0.20 REF	0.18	2.85*	2.20	2.85*	1.40	0.50 BSC	0.30	0.00*	0°
	NOM	0.75	0.02		0.25	3.00	-	3.00	-		0.40	-	-
	MAX	0.80	0.05		0.30	3.15*	2.70	3.15*	1.75		0.50	0.15	14°

JEDEC Registration MO-229, Variation WEED-5, Issue C, Aug. 2003.

* This dimension is not specified in the JEDEC drawing.

Drawings not to scale.

Supertex Doc.#: DSPD-10DFNK73X3P050, Version D041309.

(The package drawing(s) in this data sheet may not reflect the most current specifications. For the latest package outline information go to <http://www.supertex.com/packaging.html>.)

Supertex inc. does not recommend the use of its products in life support applications, and will not knowingly sell them for use in such applications unless it receives an adequate "product liability indemnification insurance agreement." **Supertex inc.** does not assume responsibility for use of devices described, and limits its liability to the replacement of the devices determined defective due to workmanship. No responsibility is assumed for possible omissions and inaccuracies. Circuitry and specifications are subject to change without notice. For the latest product specifications refer to the **Supertex inc.** (website: <http://www.supertex.com>)

X-ON Electronics

Largest Supplier of Electrical and Electronic Components

Click to view similar products for [Display Drivers & Controllers](#) category:

Click to view products by [Microchip](#) manufacturer:

Other Similar products are found below :

[ICB2FL01G](#) [HV5812PJ-G-M904](#) [TW8813-LB2-GR](#) [TW8811-PC2-GR](#) [MAX1839EEP+](#) [TW9907-TA1-GR](#) [LX27901IDW](#) [SSD2828QN4](#)
[ICB2FL01GXUMA2](#) [DLP2000FQC](#) [PAD1000YFFR](#) [S1D13746F01A600](#) [FIN324CMLX](#) [AD8387JSVZ](#) [DLPC6421ZPC](#) [HV852K7-G](#)
[HV859K7-G](#) [HV857K7-G](#) [DIO2133CT14](#) [S1D13506F00A200](#) [S1D13L03F00A100-40](#) [TW2836-BA1-GR](#) [SSD2829QL9](#) [MAX749CSA+T](#)
[MAX4820EUP+T](#) [ICL7135CAI+](#) [ICL7135CMH+D](#) [ICL7137CMH+D](#) [MAX25221BATJ/V+](#) [S1D13748B00B100](#) [S1D13A05B00B200](#)
[MAX3738ETG+T](#) [MAX8722CEEG+](#) [MAX749CPA+](#) [MAX8785AETI+](#) [ICL7135CQI+](#) [HV518PJ-G-M903](#) [HV5812P-G](#) [HV5812PJ-G](#)
[HV7224PG-G](#) [HV853K7-G](#) [HV860K7-G](#) [HV6810WG-G](#) [HV823LG-G](#) [HV857MG-G](#) [HV833MG-G](#) [HV857LMG-G](#) [HV859MG-G](#)
[FMS6363ACSX](#) [FMS6364AMTC14X](#)