

## High Current LED Driver Demoboard

### General Description

The HV9918DB1 demoboard is a high current LED driver designed to drive one or two LEDs at 700mA from a 9.0 - 16VDC input. The demoboard uses Supertex's HV9918 hysteretic buck LED driver IC.

The HV9918DB1 includes digital control of PWM dimming, which allows the user to dim the LEDs using an external, TTL-compatible square wave source applied between **DIM** and **GND**. In this case, the PWM dimming frequency and duty ratio are set by the external square wave source.

The demoboard is protected against short circuit and open LED conditions. It also includes thermal derating of the LED current using an external NTC resistor to prevent over-heating.

The bottom of the HV9918DB1 is an exposed copper plane (connected to the input ground) which can be connected to a 1" square heatsink (eg: 374324B00035G from Aavid Thermalloy) to allow for operation in higher ambient temperatures without tripping the HV9918's built-in over temperature protection.

### Specifications

Parameter	Value
Input voltage	9.0 - 16VDC
Output voltage	2.0 - 7.0V
Output current	700mA $\pm$ 5%
Line and load regulation	< $\pm$ 2%
Output current ripple	5% (peak to peak)
Full load efficiency (@12.0V input)	87%
Open LED protection	Yes
Output short circuit protection	Yes
Dimensions	25.4mm X 29.2mm

### Connection Diagram

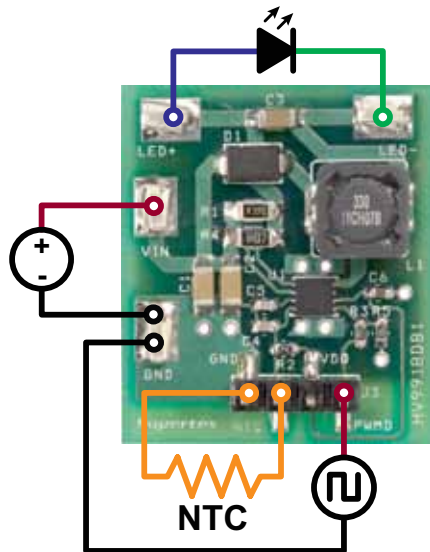

### Silk Screen

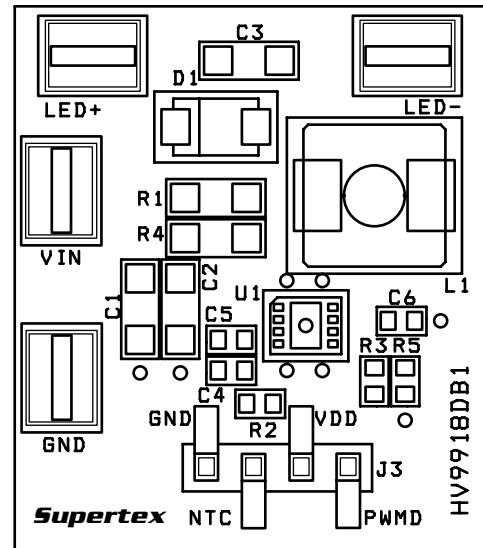

### Connections

**Input Connection:** Connect the input DC voltage between **VIN** and **GND** terminals.

**Output Connection:** Connect the LED(s) between **LED+** (anode of LED string) and **LED-** (cathode of LED string) terminals.

#### **PWM Dimming Connection:**

1. If no PWM dimming is required, short **PWMD** and **VDD** terminals.

2. If dimming using an external PWM dimming source, connect the PWM source between the **PWMD** and **GND** terminals.

#### **NTC Thermistor Connection:**

1. If no thermal derating is required, the **NTC** terminal can be left open.
2. If thermal derating of the LED current is required, the NTC thermistor can be connected between **NTC** and **GND** terminals as shown.

## Operation of the Board

The HV9918DB1 uses Supertex's HV9918 hysteretic buck LED driver IC to control the LED current. Since the regulation method controls both the peak and the valley current in the inductor, the demoboard has excellent line and load regulation.

The LED current can be controlled in by PWM dimming. PWM dimming can be achieved in one of two ways:

1. Analog control of PWM dimming where a 0-2V source can be applied between **NTC** and **GND** terminals (the **NTC** terminal can also be used for thermal derating of the LED current as explained in the next section).
2. Direct control of PWM dimming by applying a TTL compatible square wave source between **PWMD** and **GND** terminals.

## Analog Control of PWM Dimming / Thermal Derating

Analog Control of PWM dimming can be accomplished by applying a 0 – 2.0V DC voltage between **NTC** and **GND** (the DC voltage must have a 500 $\mu$ A source/sink capability). In this case, **PWMD** is connected to **VDD** and the LEDs are dimmed at 1.0kHz (as set by the capacitor at the RAMP pin of the IC). The duty cycle of the LED current can be adjusted by varying the external voltage at **NTC** (0V = 0% LED current and 2.0V = 100% LED current).

The same **NTC** terminal can instead be used to de-rate the LED current based on the LED temperature, if desired. This would reduce the LED current as the LED temperature rises and prevents over-heating of the LED. An NTC resistor can be used to sense the temperature of the LED and this resistor can be connected between the **NTC** and **GND** terminals of the HV9918DB1. The demoboard is designed to operate with a 100k NTC thermistor which has a B-constant of 4250 (eg: NCP18WF104 from Murata). With this NTC thermistor, the LED current will start dropping at 85°C and will reach about 350mA at 125°C.

Thermal derating in the HV9918DB1 uses the analog control of PWM dimming function to limit the LED current when the LED temperature rises. During normal operating mode (constant LED current; no PWM dimming), the LED current will be PWM dimmed at 1.0kHz. During PWM dimming mode, the thermal derating function limits the maximum PWM dimming duty cycle so that the LED current does not exceed the maximum allowable current determined by the thermal derating circuit.

## Direct Control of PWM Dimming

In the direct control method, the PWM dimming of the LEDs is achieved by driving the **PWMD** terminal using an external square wave source. In this case, PWM dimming frequency and duty cycle are set by the external source.

In this mode, if the thermal derating function is not desired, **NTC** terminal should be left open. In this case, the recommended PWM dimming frequency can be anything up to 10kHz.

If thermal derating is desired, then the NTC thermistor should be connected between the **NTC** and **GND** terminals. In this case, the PWM dimming frequency should be greater than 1.2kHz.

## Typical Waveforms (All waveforms are at 12.0V input and 6.9V LED Voltage unless otherwise noted)

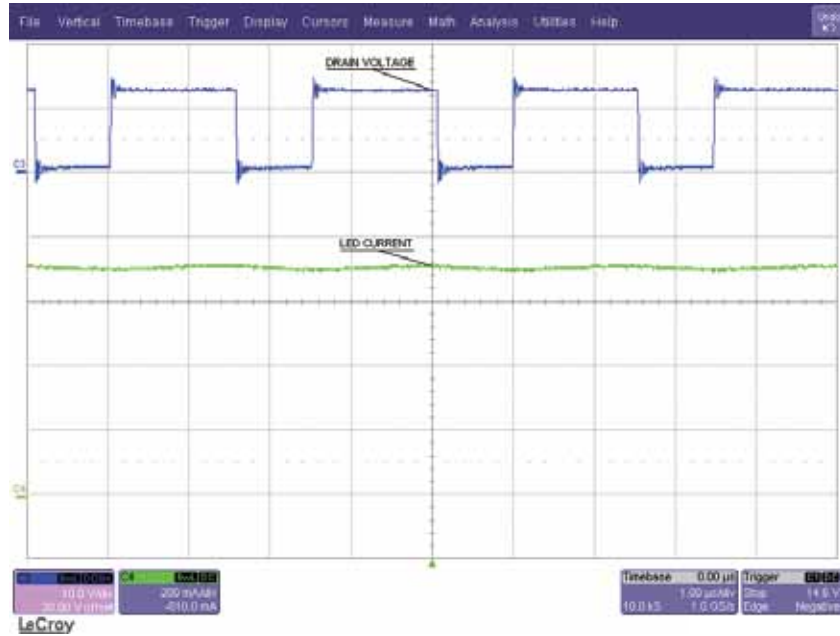

Fig. 1. Normal Operation – Drain Voltage and LED Current

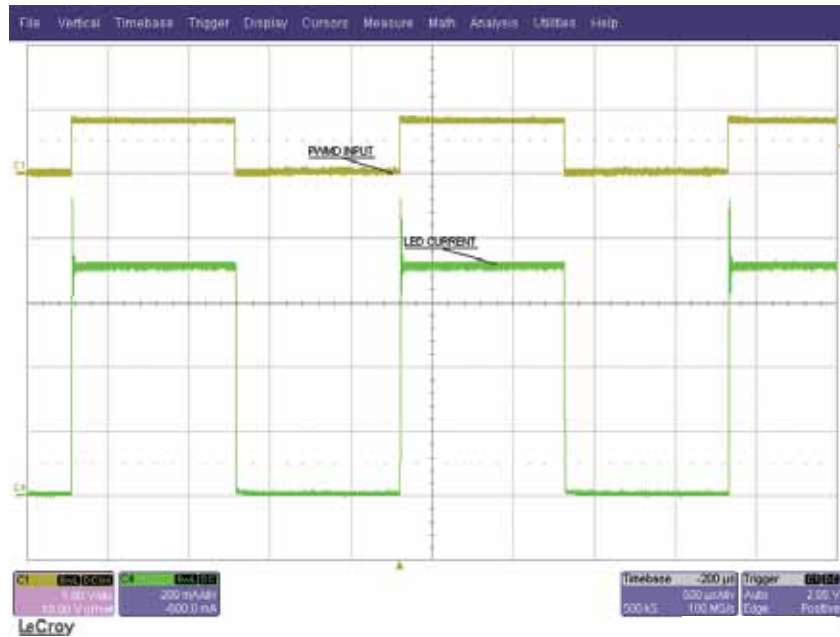

Fig. 2. PWM Dimming Waveform

Typical Waveforms (All waveforms are at 12.0V input and 6.9V LED Voltage unless otherwise noted)



Fig. 3. PWM Dimming – Rising Edge Waveform



Fig. 4. PWM Dimming – Falling Edge Waveform

Typical Waveforms (All waveforms are at 12.0V input and 6.9V LED Voltage unless otherwise noted)

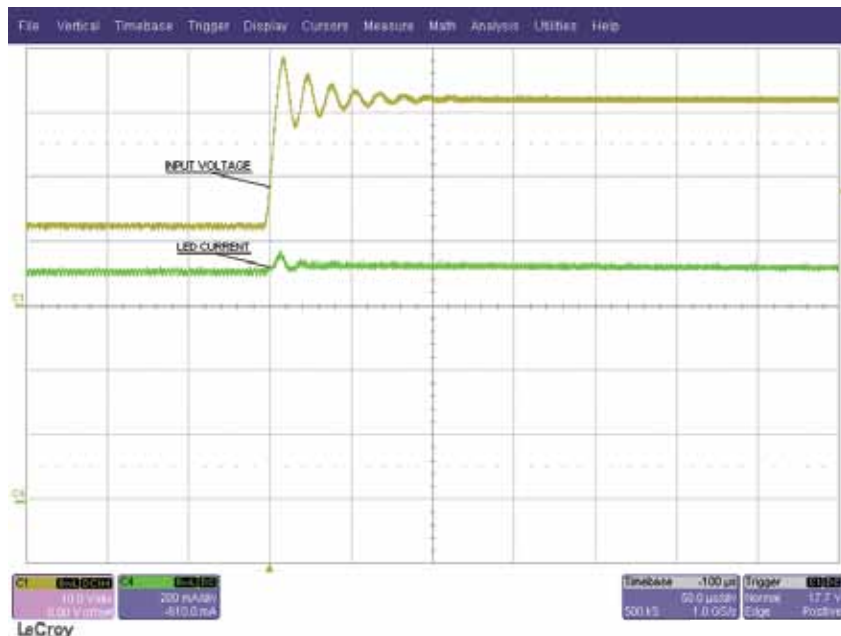

Fig. 5. Transient Response of LED Current to a Step Change in Input Current from 12V to 32V



Fig. 6. PWM Dimming of LED current with 2.78k between NTC and GND

Typical Results

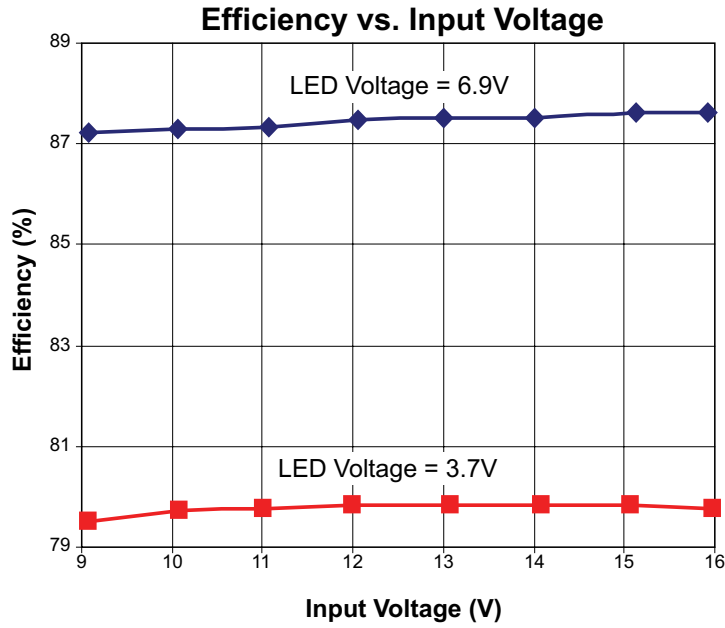

Fig. 7. Efficiency vs. Input Voltage

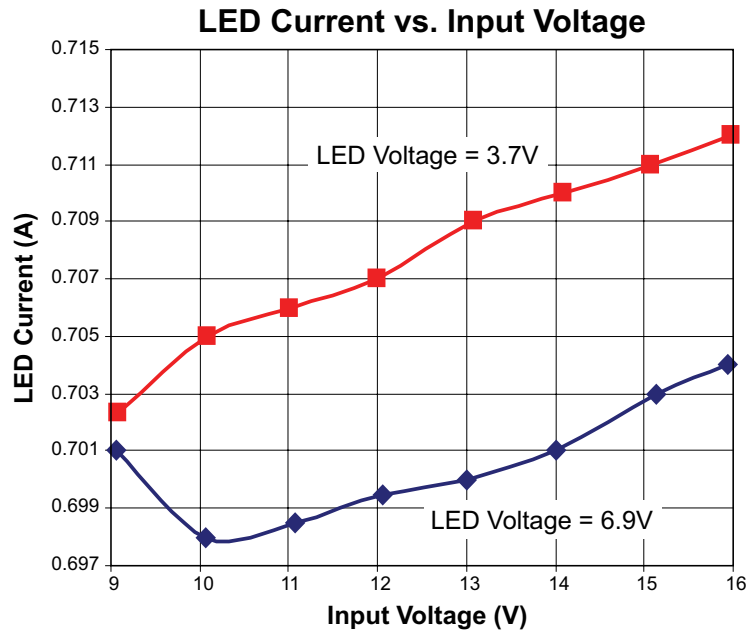

Fig. 8 Line Regulation of LED Current

Typical Results

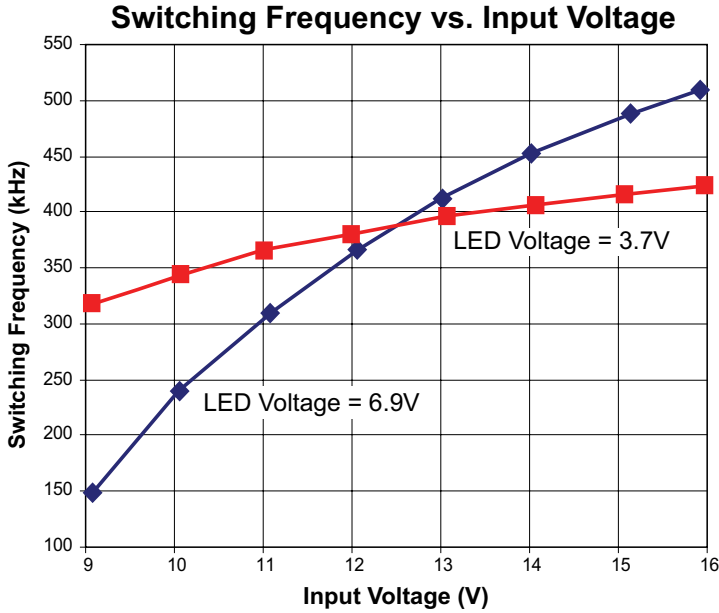

Fig. 9 Switching Frequency vs. Input Voltage

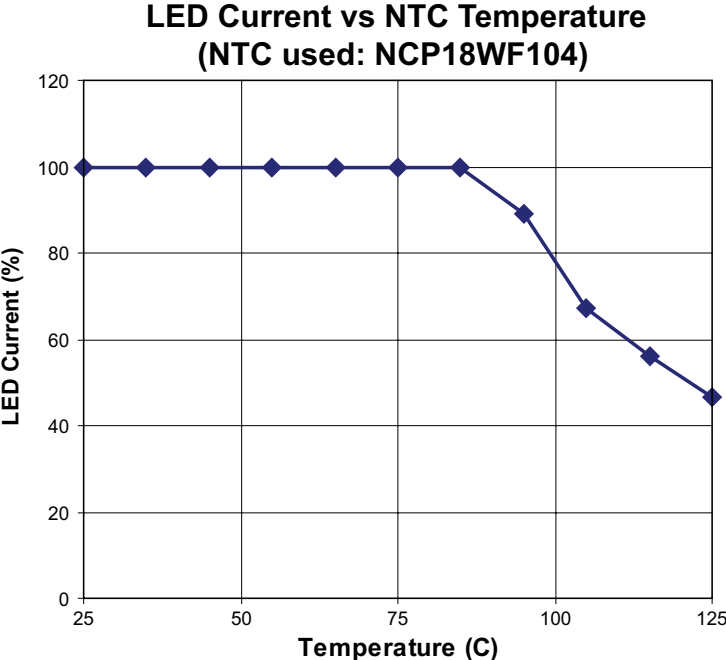
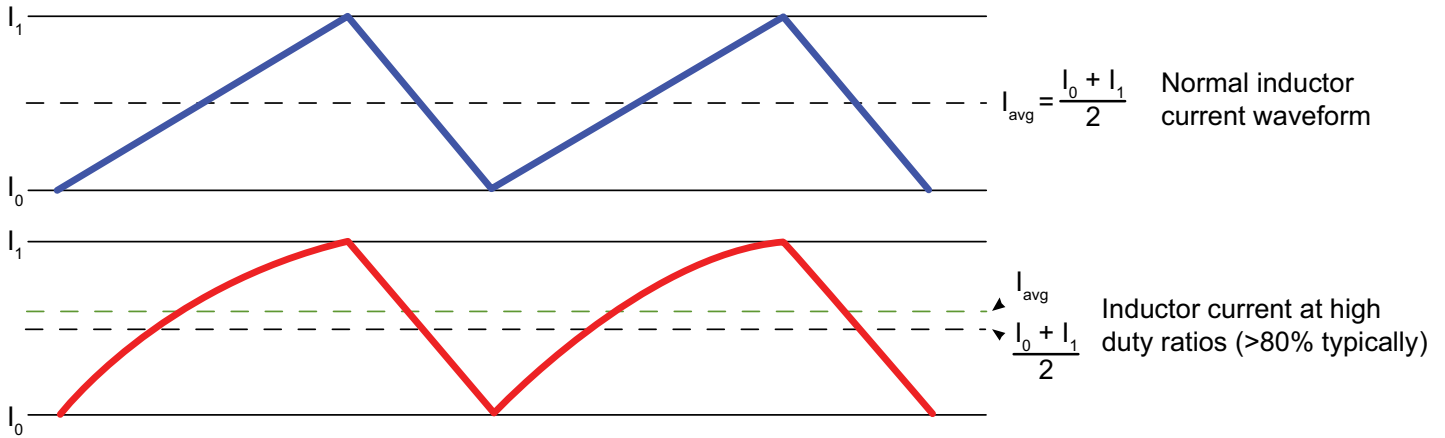

Fig. 10. Thermal Derating of the LED Current

## HV9918DB1 Waveforms



**Note:**

The increase in the LED current at 9.0V input and 6.7V output can be explained by the fact that when the difference between the input and output voltages is very small, the rising inductor current waveform becomes

more exponential rather than linear (the falling edge of the inductor current remains linear because the output voltage is high). This causes the average inductor (and therefore LED) current to increase even though the upper and lower bounds are still the same

## HV9918DB1 Schematic Diagram

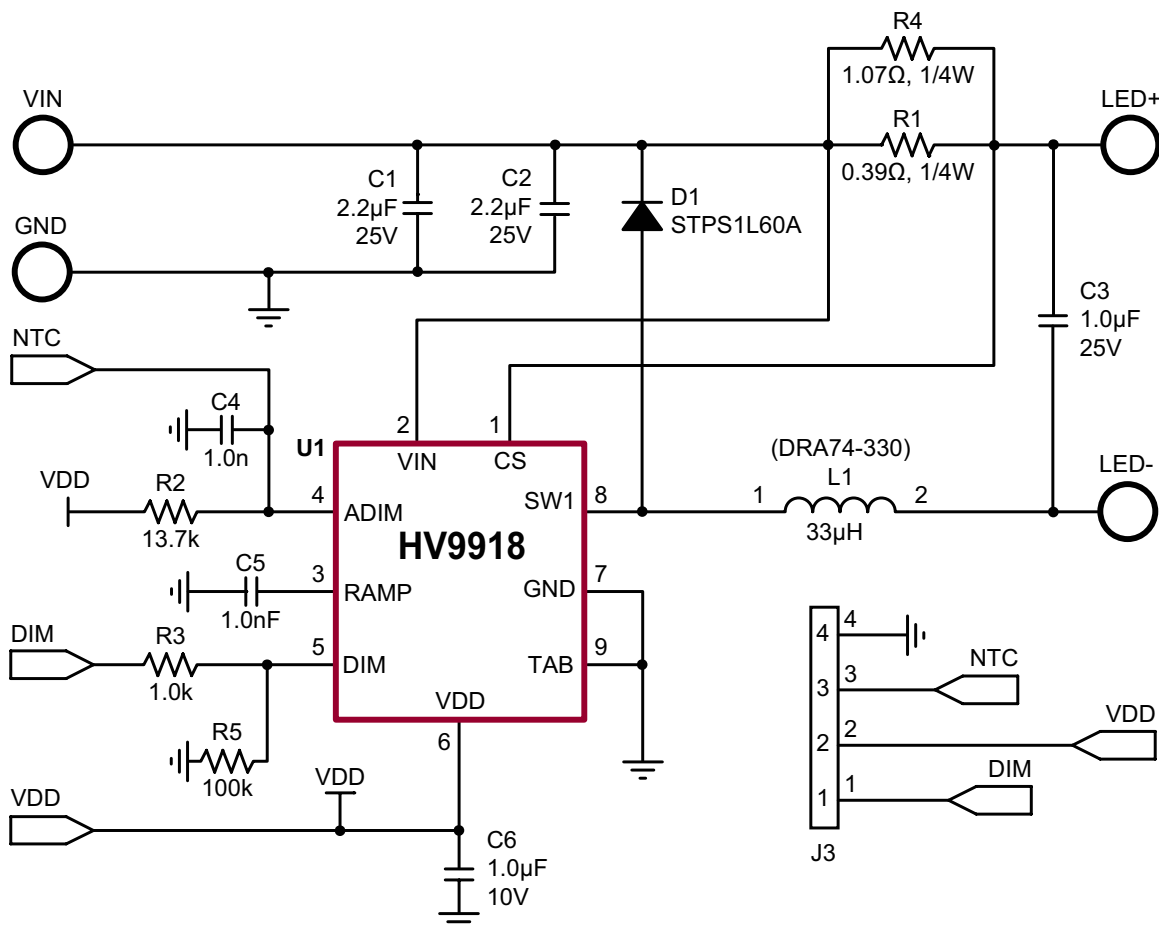



## Bill of Materials

Item #	Qty	RefDes	Description	Package	Manufacturer	Manufacturer's Part Number
1	2	C1,C2	2.2 $\mu$ F, 25V, 10% X7R ceramic capacitor	SMD1206	AVX Corp	12063C225K4Z2A
2	1	C3	1.0 $\mu$ F, 25V, 10% X7R ceramic capacitor	SMD1206	Kemet	C1206C105K3RACTU
3	2	C4,C5	1.0nF, 50V, 5%, C0G ceramic capacitor	SMD0603	TDK Corp	C1608C0G1H102J
4	1	C6	1.0 $\mu$ F, 10V, 10% X7R ceramic capacitor	SMD0603	Taiyo Yuden	LMK107B7105KA-T
5	1	D1	60V, 1.0A schottky diode	SMA	ST Micro	STPS1L60A
6	4	VIN, LED-, LED+, GND	Compact surface mount test point	SMT	Keystone Electronics	5016
7	1	J3	4 position, 0.1" vertical header	SMT	Molex	68301-1015
8	1	L1	33 $\mu$ H, 1.6A rms, 1.3A sat inductor	SMT	Coiltronics	DRA74-330-R
9	1	R1	0.39 $\Omega$ , 1/4W, 1% chip resistor	SMD1206	Rohm	MCR18EZHFLR390
10	1	R2	13.7k $\Omega$ , 1/10W, 5% chip resistor	SMD0603	Yageo	RC0603FR-0713K7L
11	1	R3	1.00k $\Omega$ , 1/10W, 5% chip resistor	SMD0603	Panasonic	ERJ-3GEYJ102V
12	1	R4	1.07 $\Omega$ , 1/4W, 1% chip resistor	SMD1206	Yageo	RC1206FR-071R07L
13	1	R5	100k $\Omega$ , 1/10W, 5% chip resistor	SMD0603	Panasonic	ERJ-3GEYJ104V
14	1	U1	Hysteretic Buck LED Driver with integrated FET	DFN-8	Supertex	HV9918K7-G

**Supertex inc.** does not recommend the use of its products in life support applications, and will not knowingly sell them for use in such applications unless it receives an adequate "product liability indemnification insurance agreement." **Supertex inc.** does not assume responsibility for use of devices described, and limits its liability to the replacement of the devices determined defective due to workmanship. No responsibility is assumed for possible omissions and inaccuracies. Circuitry and specifications are subject to change without notice. For the latest product specifications refer to the **Supertex inc.** (website: <http://www.supertex.com>)

## X-ON Electronics

Largest Supplier of Electrical and Electronic Components

*Click to view similar products for [LED Lighting Development Tools](#) category:*

*Click to view products by [Microchip](#) manufacturer:*

Other Similar products are found below :

[MIC2870YFT EV](#) [TDGL014](#) [ISL97682IRTZEVALZ](#) [EA6358NH](#) [TPS92315EVM-516](#) [STEVAL-LLL006V1](#) [IS31LT3948-GRLS4-EB](#)  
[PIM526](#) [PIM527](#) [MAX6946EVKIT+](#) [MAX20070EVKIT#](#) [MAX20090BEVKIT#](#) [PIM498](#) [AP8800EV1](#) [ZXLD1370/1EV4](#) [TLC59116EVM-](#)  
[390](#) [1216.1013](#) [TPS61176EVM-566](#) [TPS92001EVM-628](#) [1270](#) [1271.2004](#) [1272.1030](#) [1273.1010](#) [1278.1010](#) [1279.1002](#) [1279.1001](#)  
[1282.1000](#) [1293.1900](#) [1293.1800](#) [1293.1700](#) [1293.1500](#) [1293.1100](#) [1282.1400](#) [1282.1100](#) [1293.1200](#) [1282.1200](#) [1293.1000](#) [1282.6000](#)  
[1296.2012](#) [MIKROE-2520](#) [1721](#) [1762](#) [PIR-GEVB](#) [TPS61161EVM-243](#) [TLC6C5712EVM](#) [TLC59116FEVM-571](#) [STEVAL-ILL056V1](#)  
[ADM00767](#) [STEVAL-ILL080V1](#) [DC1224A](#)