



LAN8720A/LAN8720Ai

Small Footprint RMII 10/100 Ethernet Transceiver with HP Auto-MDIX Support



PRODUCT FEATURES

Datasheet

Highlights

- Single-Chip Ethernet Physical Layer Transceiver (PHY)
- Comprehensive flexPWR[®] Technology
 - Flexible Power Management Architecture
 - LVCMOS Variable I/O voltage range: +1.6V to +3.6V
 - Integrated 1.2V regulator
- HP Auto-MDIX support
- Miniature 24-pin QFN lead-free RoHS compliant package (4 x 4 x 0.85mm height).

Target Applications

- Set-Top Boxes
- Networked Printers and Servers
- Test Instrumentation
- LAN on Motherboard
- Embedded Telecom Applications
- Video Record/Playback Systems
- Cable Modems/Routers
- DSL Modems/Routers
- Digital Video Recorders
- IP and Video Phones
- Wireless Access Points
- Digital Televisions
- Digital Media Adaptors/Servers
- Gaming Consoles
- POE Applications (Refer to SMSC Application Note 17.18)

Key Benefits

- High-Performance 10/100 Ethernet Transceiver
 - Compliant with IEEE802.3/802.3u (Fast Ethernet)
 - Compliant with ISO 802-3/IEEE 802.3 (10BASE-T)
 - Loop-back modes
 - Auto-negotiation
 - Automatic polarity detection and correction
 - Link status change wake-up detection
 - Vendor specific register functions
 - Supports the reduced pin count RMII interface
- Power and I/Os
 - Various low power modes
 - Integrated power-on reset circuit
 - Two status LED outputs
 - Latch-Up Performance Exceeds 150mA per EIA/JESD 78, Class II
 - May be used with a single 3.3V supply
- Additional Features
 - Ability to use a low cost 25Mhz crystal for reduced BOM
- Packaging
 - 24-pin QFN (4x4 mm) Lead-Free RoHS Compliant package with RMII
- Environmental
 - Extended commercial temperature range (0°C to +85°C)
 - Industrial temperature range version available (-40°C to +85°C)

Datasheet

Order Numbers:

LAN8720A-CP-TR for 24-pin QFN lead-free RoHS compliant package (0 to +85°C temp)

LAN8720Ai-CP-TR for 24-pin QFN lead-free RoHS compliant package (-40 to +85°C temp)

Reel size is 4,000.

This product meets the halogen maximum concentration values per IEC61249-2-21

For RoHS compliance and environmental information, please visit www.smSC.com/rohs

Please contact your SMSC sales representative for additional documentation related to this product such as application notes, anomaly sheets, and design guidelines.

Copyright © 2012 SMSC or its subsidiaries. All rights reserved.

Circuit diagrams and other information relating to SMSC products are included as a means of illustrating typical applications. Consequently, complete information sufficient for construction purposes is not necessarily given. Although the information has been checked and is believed to be accurate, no responsibility is assumed for inaccuracies. SMSC reserves the right to make changes to specifications and product descriptions at any time without notice. Contact your local SMSC sales office to obtain the latest specifications before placing your product order. The provision of this information does not convey to the purchaser of the described semiconductor devices any licenses under any patent rights or other intellectual property rights of SMSC or others. All sales are expressly conditional on your agreement to the terms and conditions of the most recently dated version of SMSC's standard Terms of Sale Agreement dated before the date of your order (the "Terms of Sale Agreement"). The product may contain design defects or errors known as anomalies which may cause the product's functions to deviate from published specifications. Anomaly sheets are available upon request. SMSC products are not designed, intended, authorized or warranted for use in any life support or other application where product failure could cause or contribute to personal injury or severe property damage. Any and all such uses without prior written approval of an Officer of SMSC and further testing and/or modification will be fully at the risk of the customer. Copies of this document or other SMSC literature, as well as the Terms of Sale Agreement, may be obtained by visiting SMSC's website at <http://www.smSC.com>. SMSC is a registered trademark of Standard Microsystems Corporation ("SMSC"). Product names and company names are the trademarks of their respective holders.

The Microchip name and logo, and the Microchip logo are registered trademarks of Microchip Technology Incorporated in the U.S.A. and other countries.

SMSC DISCLAIMS AND EXCLUDES ANY AND ALL WARRANTIES, INCLUDING WITHOUT LIMITATION ANY AND ALL IMPLIED WARRANTIES OF MERCHANTABILITY, FITNESS FOR A PARTICULAR PURPOSE, TITLE, AND AGAINST INFRINGEMENT AND THE LIKE, AND ANY AND ALL WARRANTIES ARISING FROM ANY COURSE OF DEALING OR USAGE OF TRADE. IN NO EVENT SHALL SMSC BE LIABLE FOR ANY DIRECT, INCIDENTAL, INDIRECT, SPECIAL, PUNITIVE, OR CONSEQUENTIAL DAMAGES; OR FOR LOST DATA, PROFITS, SAVINGS OR REVENUES OF ANY KIND; REGARDLESS OF THE FORM OF ACTION, WHETHER BASED ON CONTRACT; TORT; NEGLIGENCE OF SMSC OR OTHERS; STRICT LIABILITY; BREACH OF WARRANTY; OR OTHERWISE; WHETHER OR NOT ANY REMEDY OF BUYER IS HELD TO HAVE FAILED OF ITS ESSENTIAL PURPOSE, AND WHETHER OR NOT SMSC HAS BEEN ADVISED OF THE POSSIBILITY OF SUCH DAMAGES.

Table of Contents

Chapter 1 Introduction	7
1.1 General Terms and Conventions	7
1.2 General Description	7
Chapter 2 Pin Description and Configuration	9
2.1 Pin Assignments	15
2.2 Buffer Types	16
Chapter 3 Functional Description	17
3.1 Transceiver	17
3.1.1 100BASE-TX Transmit	17
3.1.2 100BASE-TX Receive	20
3.1.3 10BASE-T Transmit	22
3.1.4 10BASE-T Receive	23
3.2 Auto-negotiation	23
3.2.1 Parallel Detection	25
3.2.2 Restarting Auto-negotiation	25
3.2.3 Disabling Auto-negotiation	25
3.2.4 Half vs. Full Duplex	25
3.3 HP Auto-MDIX Support	26
3.4 MAC Interface	27
3.4.1 RMII	27
3.5 Serial Management Interface (SMI)	28
3.6 Interrupt Management	29
3.6.1 Primary Interrupt System	29
3.6.2 Alternate Interrupt System	30
3.7 Configuration Straps	31
3.7.1 PHYAD[0]: PHY Address Configuration	31
3.7.2 MODE[2:0]: Mode Configuration	31
3.7.3 REGOFF: Internal +1.2V Regulator Configuration	32
3.7.4 nINTSEL: nINT/REFCLKO Configuration	33
3.8 Miscellaneous Functions	37
3.8.1 LEDs	37
3.8.2 Variable Voltage I/O	38
3.8.3 Power-Down Modes	38
3.8.4 Isolate Mode	39
3.8.5 Resets	39
3.8.6 Carrier Sense	39
3.8.7 Link Integrity Test	40
3.8.8 Loopback Operation	40
3.9 Application Diagrams	41
3.9.1 Simplified System Level Application Diagram	42
3.9.2 Power Supply Diagram (1.2V Supplied by Internal Regulator)	43
3.9.3 Power Supply Diagram (1.2V Supplied by External Source)	44
3.9.4 Twisted-Pair Interface Diagram (Single Power Supply)	45
3.9.5 Twisted-Pair Interface Diagram (Dual Power Supplies)	46
Chapter 4 Register Descriptions	47
4.1 Register Nomenclature	47
4.2 Control and Status Registers	48
4.2.1 Basic Control Register	49

Datasheet

4.2.2	Basic Status Register	50
4.2.3	PHY Identifier 1 Register	51
4.2.4	PHY Identifier 2 Register	52
4.2.5	Auto Negotiation Advertisement Register	53
4.2.6	Auto Negotiation Link Partner Ability Register	54
4.2.7	Auto Negotiation Expansion Register	55
4.2.8	Mode Control/Status Register	56
4.2.9	Special Modes Register	57
4.2.10	Symbol Error Counter Register	58
4.2.11	Special Control/Status Indications Register	59
4.2.12	Interrupt Source Flag Register	60
4.2.13	Interrupt Mask Register	61
4.2.14	PHY Special Control/Status Register	62
<hr/>		
Chapter 5	Operational Characteristics	63
5.1	Absolute Maximum Ratings*	63
5.2	Operating Conditions**	64
5.3	Power Consumption	64
5.3.1	REF_CLK In Mode	64
5.3.2	REF_CLK Out Mode	65
5.4	DC Specifications	66
5.5	AC Specifications	68
5.5.1	Equivalent Test Load	68
5.5.2	Power Sequence Timing	69
5.5.3	Power-On nRST & Configuration Strap Timing	70
5.5.4	RMII Interface Timing	71
5.5.5	SMI Timing	73
5.6	Clock Circuit	74
<hr/>		
Chapter 6	Package Outline	75
<hr/>		
Chapter 7	Datasheet Revision History	78

List of Figures

Figure 1.1	System Block Diagram	8
Figure 1.2	Architectural Overview	8
Figure 2.1	24-QFN Pin Assignments (TOP VIEW)	9
Figure 3.1	100BASE-TX Transmit Data Path	17
Figure 3.2	100BASE-TX Receive Data Path	20
Figure 3.3	Relationship Between Received Data and Specific MII Signals	21
Figure 3.4	Direct Cable Connection vs. Cross-over Cable Connection	26
Figure 3.5	MDIO Timing and Frame Structure - READ Cycle	28
Figure 3.6	MDIO Timing and Frame Structure - WRITE Cycle	28
Figure 3.7	External 50MHz clock sources the REF_CLK	34
Figure 3.8	Sourcing REF_CLK from a 25MHz Crystal	35
Figure 3.9	Sourcing REF_CLK from External 25MHz Source	36
Figure 3.10	LED1/REGOFF Polarity Configuration	37
Figure 3.11	LED2/nINTSEL Polarity Configuration	38
Figure 3.12	Near-end Loopback Block Diagram	40
Figure 3.13	Far Loopback Block Diagram	41
Figure 3.14	Connector Loopback Block Diagram	41
Figure 3.15	Simplified System Level Application Diagram	42
Figure 3.16	Power Supply Diagram (1.2V Supplied by Internal Regulator)	43
Figure 3.17	Power Supply Diagram (1.2V Supplied by External Source)	44
Figure 3.18	Twisted-Pair Interface Diagram (Single Power Supply)	45
Figure 3.19	Twisted-Pair Interface Diagram (Dual Power Supplies)	46
Figure 5.1	Output Equivalent Test Load	68
Figure 5.2	Power Sequence Timing	69
Figure 5.3	Power-On nRST & Configuration Strap Timing	70
Figure 5.4	RMII Timing (REF_CLK Out Mode)	71
Figure 5.5	RMII Timing (REF_CLK In Mode)	72
Figure 5.6	SMI Timing	73

Datasheet**List of Tables**

Table 2.1	RMII Signals	10
Table 2.2	LED Pins	11
Table 2.3	Serial Management Interface (SMI) Pins	12
Table 2.4	Ethernet Pins	12
Table 2.5	Miscellaneous Pins	13
Table 2.6	Analog Reference Pins	14
Table 2.7	Power Pins	14
Table 2.8	24-QFN Package Pin Assignments	15
Table 2.9	Buffer Types	16
Table 3.1	4B/5B Code Table	18
Table 3.2	Interrupt Management Table	29
Table 3.3	Alternative Interrupt System Management Table	30
Table 3.4	MODE[2:0] Bus	32
Table 3.5	Pin Names for Mode Bits	32
Table 3.6	nINTSEL Configuration	33
Table 4.1	Register Bit Types	47
Table 4.2	SMI Register Map	48
Table 5.1	Device Only Current Consumption and Power Dissipation (REF_CLK In Mode)	64
Table 5.2	Device Only Current Consumption and Power Dissipation (REF_CLK Out Mode)	65
Table 5.3	Non-Variable I/O Buffer Characteristics	66
Table 5.4	Variable I/O Buffer Characteristics	67
Table 5.5	100BASE-TX Transceiver Characteristics	67
Table 5.6	10BASE-T Transceiver Characteristics	68
Table 5.7	Power Sequence Timing Values	69
Table 5.8	Power-On nRST & Configuration Strap Timing Values	70
Table 5.9	RMII Timing Values (REF_CLK Out Mode)	71
Table 5.10	RMII Timing Values (REF_CLK In Mode)	72
Table 5.11	RMII CLKIN (REF_CLK) Timing Values	73
Table 5.12	SMI Timing Values	73
Table 5.13	Crystal Specifications	74
Table 7.1	Customer Revision History	78

Chapter 1 Introduction

1.1 General Terms and Conventions

The following is list of the general terms used throughout this document:

BYTE	8-bits
FIFO	First In First Out buffer; often used for elasticity buffer
MAC	Media Access Controller
RMII™	Reduced Media Independent Interface™
N/A	Not Applicable
X	Indicates that a logic state is “don’t care” or undefined.
RESERVED	Refers to a reserved bit field or address. Unless otherwise noted, reserved bits must always be zero for write operations. Unless otherwise noted, values are not guaranteed when reading reserved bits. Unless otherwise noted, do not read or write to reserved addresses.
SMI	Serial Management Interface

1.2 General Description

The LAN8720A/LAN8720Ai is a low-power 10BASE-T/100BASE-TX physical layer (PHY) transceiver with variable I/O voltage that is compliant with the IEEE 802.3-2005 standards.

The LAN8720A/LAN8720Ai supports communication with an Ethernet MAC via a standard RMII interface. It contains a full-duplex 10-BASE-T/100BASE-TX transceiver and supports 10Mbps (10BASE-T) and 100Mbps (100BASE-TX) operation. The LAN8720A/LAN8720Ai implements auto-negotiation to automatically determine the best possible speed and duplex mode of operation. HP Auto-MDIX support allows the use of direct connect or cross-over LAN cables.

The LAN8720A/LAN8720Ai supports both IEEE 802.3-2005 compliant and vendor-specific register functions. However, no register access is required for operation. The initial configuration may be selected via the configuration pins as described in [Section 3.7, "Configuration Straps," on page 31](#). Register-selectable configuration options may be used to further define the functionality of the transceiver.

Per IEEE 802.3-2005 standards, all digital interface pins are tolerant to 3.6V. The device can be configured to operate on a single 3.3V supply utilizing an integrated 3.3V to 1.2V linear regulator. The linear regulator may be optionally disabled, allowing usage of a high efficiency external regulator for lower system power dissipation.

The LAN8720A/LAN8720Ai is available in both extended commercial and industrial temperature range versions. A typical system application is shown in [Figure 1.1](#).

Datasheet

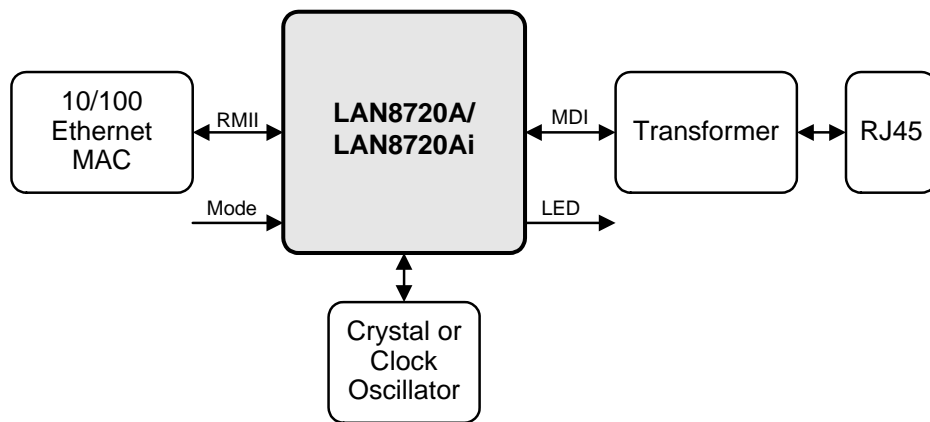

Figure 1.1 System Block Diagram

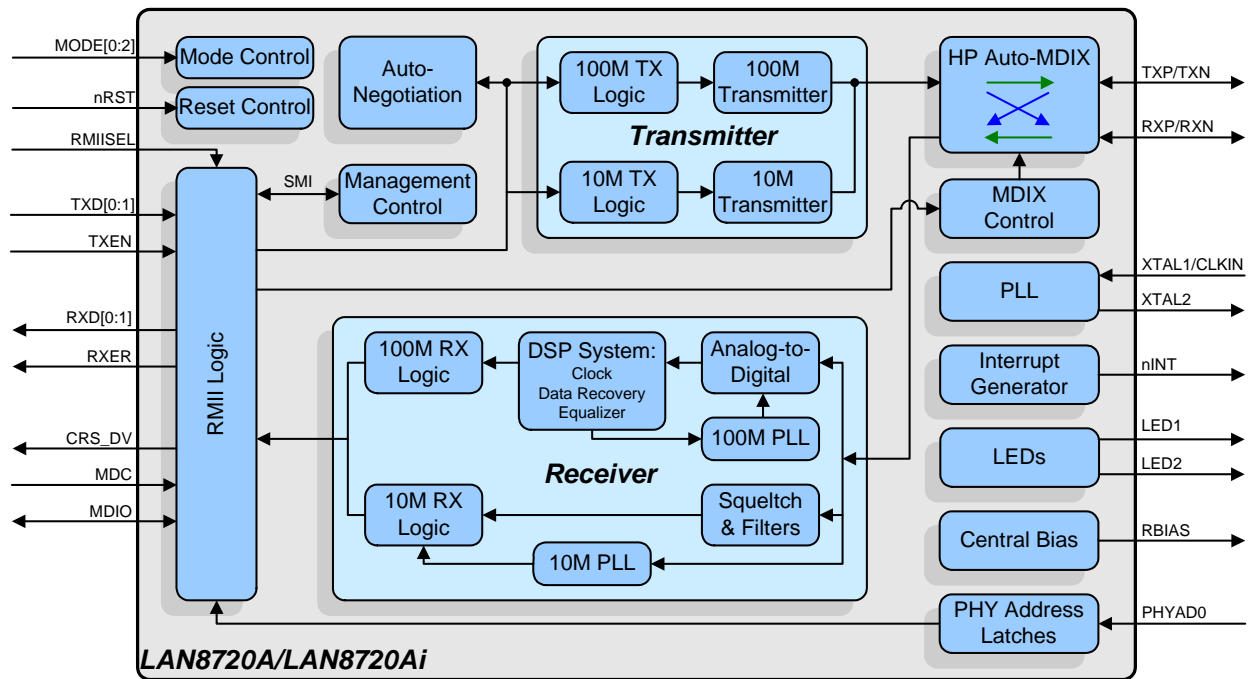
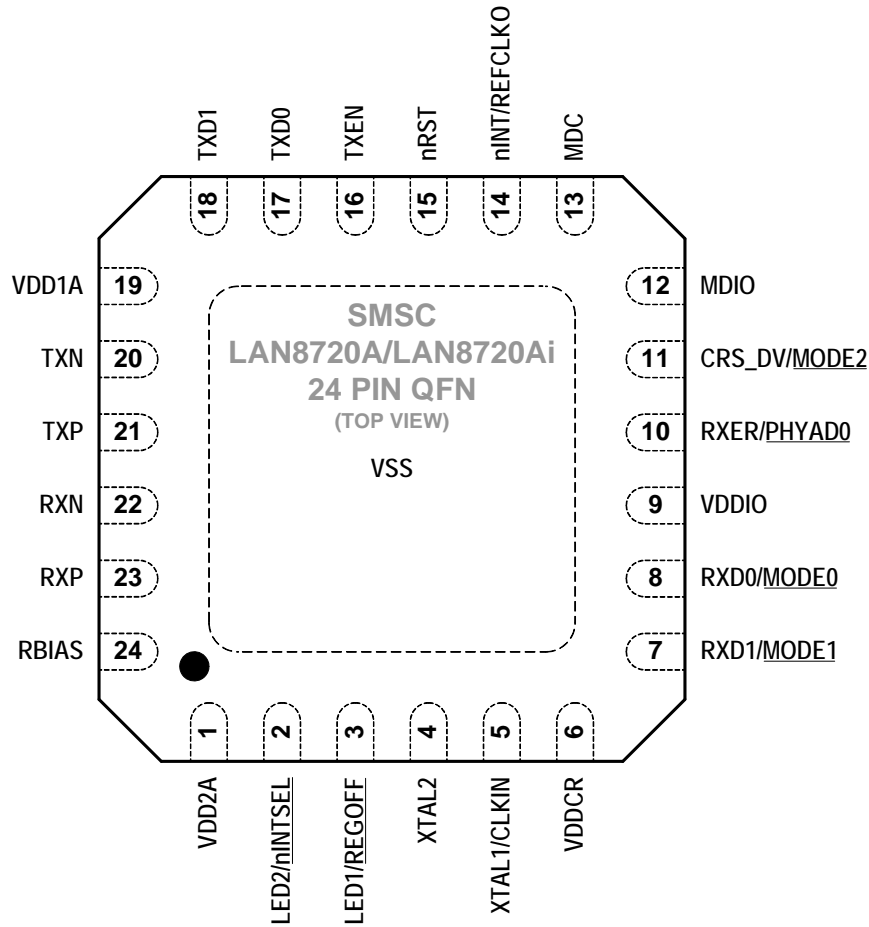

Figure 1.2 Architectural Overview

Chapter 2 Pin Description and Configuration



NOTE: Exposed pad (VSS) on bottom of package must be connected to ground

Figure 2.1 24-QFN Pin Assignments (TOP VIEW)

Note: When a lower case “n” is used at the beginning of the signal name, it indicates that the signal is active low. For example, nRST indicates that the reset signal is active low.

Note: The buffer type for each signal is indicated in the BUFFER TYPE column. A description of the buffer types is provided in [Section 2.2](#).

Datasheet

Table 2.1 RMII Signals

NUM PINS	NAME	SYMBOL	BUFFER TYPE	DESCRIPTION
1	Transmit Data 0	TXD0	VIS	The MAC transmits data to the transceiver using this signal.
1	Transmit Data 1	TXD1	VIS	The MAC transmits data to the transceiver using this signal.
1	Transmit Enable	TXEN	VIS (PD)	Indicates that valid transmission data is present on TXD[1:0].
1	Receive Data 0	RXD0	VO8	Bit 0 of the 2 data bits that are sent by the transceiver on the receive path.
	PHY Operating Mode 0 Configuration Strap	<u>MODE0</u>	VIS (PU)	Combined with MODE1 and MODE2, this configuration strap sets the default PHY mode. See Note 2.1 for more information on configuration straps. Note: Refer to Section 3.7.2, "MODE[2:0]: Mode Configuration," on page 31 for additional details.
1	Receive Data 1	RXD1	VO8	Bit 1 of the 2 data bits that are sent by the transceiver on the receive path.
	PHY Operating Mode 1 Configuration Strap	<u>MODE1</u>	VIS (PU)	Combined with MODE0 and MODE2, this configuration strap sets the default PHY mode. See Note 2.1 for more information on configuration straps. Note: Refer to Section 3.7.2, "MODE[2:0]: Mode Configuration," on page 31 for additional details.
1	Receive Error	RXER	VO8	This signal is asserted to indicate that an error was detected somewhere in the frame presently being transferred from the transceiver.
	PHY Address 0 Configuration Strap	<u>PHYAD0</u>	VIS (PD)	This configuration strap sets the transceiver's SMI address. See Note 2.1 for more information on configuration straps. Note: Refer to Section 3.7.1, "PHYAD[0]: PHY Address Configuration," on page 31 for additional information.

Table 2.1 RMII Signals (continued)

NUM PINS	NAME	SYMBOL	BUFFER TYPE	DESCRIPTION
1	Carrier Sense / Receive Data Valid	CRS_DV	VO8	This signal is asserted to indicate the receive medium is non-idle. When a 10BASE-T packet is received, CRS_DV is asserted, but RXD[1:0] is held low until the SFD byte (10101011) is received. Note: Per the RMII standard, transmitted data is not looped back onto the receive data pins in 10BASE-T half-duplex mode.
	PHY Operating Mode 2 Configuration Strap	<u>MODE2</u>	VIS (PU)	Combined with MODE0 and MODE1, this configuration strap sets the default PHY mode. See Note 2.1 for more information on configuration straps. Note: Refer to Section 3.7.2, "MODE[2:0]: Mode Configuration," on page 31 for additional details.

Note 2.1 Configuration strap values are latched on power-on reset and system reset. Configuration straps are identified by an underlined symbol name. Signals that function as configuration straps must be augmented with an external resistor when connected to a load. Refer to [Section 3.7, "Configuration Straps,"](#) on page 31 for additional information.

Table 2.2 LED Pins

NUM PINS	NAME	SYMBOL	BUFFER TYPE	DESCRIPTION
1	LED 1	LED1	O12	Link activity LED Indication. This pin is driven active when a valid link is detected and blinks when activity is detected. Note: Refer to Section 3.8.1, "LEDs," on page 37 for additional LED information.
	Regulator Off Configuration Strap	<u>REGOFF</u>	IS (PD)	This configuration strap is used to disable the internal 1.2V regulator. When the regulator is disabled, external 1.2V must be supplied to VDDCR. <ul style="list-style-type: none">■ When <u>REGOFF</u> is pulled high to VDD2A with an external resistor, the internal regulator is disabled.■ When <u>REGOFF</u> is floating or pulled low, the internal regulator is enabled (default). See Note 2.2 for more information on configuration straps. Note: Refer to Section 3.7.3, "REGOFF: Internal +1.2V Regulator Configuration," on page 32 for additional details.

Datasheet

Table 2.2 LED Pins (continued)

NUM PINS	NAME	SYMBOL	BUFFER TYPE	DESCRIPTION
	LED 2	LED2	O12	Link Speed LED Indication. This pin is driven active when the operating speed is 100Mbps. It is inactive when the operating speed is 10Mbps or during line isolation. Note: Refer to Section 3.8.1, "LEDs," on page 37 for additional LED information.
1	nINT/ REFCLKO Function Select Configuration Strap	<u>nINTSEL</u>	IS (PU)	This configuration strap selects the mode of the nINT/REFCLKO pin. <ul style="list-style-type: none"> ■ When <u>nINTSEL</u> is floated or pulled to VDD2A, nINT is selected for operation on the nINT/REFCLKO pin (default). ■ When <u>nINTSEL</u> is pulled low to VSS, REFCLKO is selected for operation on the nINT/REFCLKO pin. See Note 2.2 for more information on configuration straps. Note: Refer to See Section 3.8.1.2, "nINTSEL and LED2 Polarity Selection," on page 37 for additional information.

Note 2.2 Configuration strap values are latched on power-on reset and system reset. Configuration straps are identified by an underlined symbol name. Signals that function as configuration straps must be augmented with an external resistor when connected to a load. Refer to [Section 3.7, "Configuration Straps,"](#) on [page 31](#) for additional information.

Table 2.3 Serial Management Interface (SMI) Pins

NUM PINS	NAME	SYMBOL	BUFFER TYPE	DESCRIPTION
1	SMI Data Input/Output	MDIO	VIS/ VOD8	Serial Management Interface data input/output
1	SMI Clock	MDC	VIS	Serial Management Interface clock

Table 2.4 Ethernet Pins

NUM PINS	NAME	SYMBOL	BUFFER TYPE	DESCRIPTION
1	Ethernet TX/RX Positive Channel 1	TXP	AIO	Transmit/Receive Positive Channel 1
1	Ethernet TX/RX Negative Channel 1	TXN	AIO	Transmit/Receive Negative Channel 1

Table 2.4 Ethernet Pins (continued)

NUM PINS	NAME	SYMBOL	BUFFER TYPE	DESCRIPTION
1	Ethernet TX/RX Positive Channel 2	RXP	AIO	Transmit/Receive Positive Channel 2
1	Ethernet TX/RX Negative Channel 2	RXN	AIO	Transmit/Receive Negative Channel 2

Table 2.5 Miscellaneous Pins

NUM PINS	NAME	SYMBOL	BUFFER TYPE	DESCRIPTION
1	External Crystal Input	XTAL1	ICLK	External crystal input
	External Clock Input	CLKIN	ICLK	Single-ended clock oscillator input. Note: When using a single ended clock oscillator, XTAL2 should be left unconnected.
1	External Crystal Output	XTAL2	OCLK	External crystal output
1	External Reset	nRST	VIS (PU)	System reset. This signal is active low.
1	Interrupt Output	nINT	VOD8 (PU)	Active low interrupt output. Place an external resistor pull-up to VDDIO. Note: Refer to Section 3.6, "Interrupt Management," on page 29 for additional details on device interrupts. Note: Refer to Section 3.8.1.2, "nINTSEL and LED2 Polarity Selection," on page 37 for details on how the <u>nINTSEL</u> configuration strap is used to determine the function of this pin.
	Reference Clock Output	REFCLKO	VO8	This optional 50MHz clock output is derived from the 25MHz crystal oscillator. REFCLKO is selectable via the <u>nINTSEL</u> configuration strap. Note: Refer Section 3.7.4.2, "REF_CLK Out Mode," on page 34 for additional details. Note: Refer to Section 3.8.1.2, "nINTSEL and LED2 Polarity Selection," on page 37 for details on how the <u>nINTSEL</u> configuration strap is used to determine the function of this pin.

Datasheet

Table 2.6 Analog Reference Pins

NUM PINS	NAME	SYMBOL	BUFFER TYPE	DESCRIPTION
1	External 1% Bias Resistor Input	RBIAS	AI	<p>This pin requires connection of a 12.1k ohm (1%) resistor to ground.</p> <p>Refer to the LAN8720A/LAN8720Ai reference schematic for connection information.</p> <p>Note: The nominal voltage is 1.2V and the resistor will dissipate approximately 1mW of power.</p>

Table 2.7 Power Pins

NUM PINS	NAME	SYMBOL	BUFFER TYPE	DESCRIPTION
1	+1.6V to +3.6V Variable I/O Power	VDDIO	P	<p>+1.6V to +3.6V variable I/O power</p> <p>Refer to the LAN8720A/LAN8720Ai reference schematic for connection information.</p>
1	+1.2V Digital Core Power Supply	VDDCR	P	<p>Supplied by the on-chip regulator unless configured for regulator off mode via the <u>REGOFF</u> configuration strap.</p> <p>Refer to the LAN8720A/LAN8720Ai reference schematic for connection information.</p> <p>Note: 1 uF and 470 pF decoupling capacitors in parallel to ground should be used on this pin.</p>
1	+3.3V Channel 1 Analog Port Power	VDD1A	P	<p>+3.3V Analog Port Power to Channel 1</p> <p>Refer to the LAN8720A/LAN8720Ai reference schematic for connection information.</p>
1	+3.3V Channel 2 Analog Port Power	VDD2A	P	<p>+3.3V Analog Port Power to Channel 2 and the internal regulator.</p> <p>Refer to the LAN8720A/LAN8720Ai reference schematic for connection information.</p>
1	Ground	VSS	P	<p>Common ground. This exposed pad must be connected to the ground plane with a via array.</p>

2.1 Pin Assignments

Table 2.8 24-QFN Package Pin Assignments

PIN NUM	PIN NAME	PIN NUM	PIN NAME
1	VDD2A	13	MDC
2	LED2/ <u>nINTSEL</u>	14	nINT/REFCLKO
3	LED1/ <u>REGOFF</u>	15	nRST
4	XTAL2	16	TXEN
5	XTAL1/CLKIN	17	TXD0
6	VDDCR	18	TXD1
7	RXD1/ <u>MODE1</u>	19	VDD1A
8	RXD0/ <u>MODE0</u>	20	TXN
9	VDDIO	21	TXP
10	RXER/ <u>PHYAD0</u>	22	RXN
11	CRS_DV/ <u>MODE2</u>	23	RXP
12	MDIO	24	RBIAS

Datasheet

2.2 Buffer Types

Table 2.9 Buffer Types

BUFFER TYPE	DESCRIPTION
IS	Schmitt-triggered input
O12	Output with 12mA sink and 12mA source
VIS	Variable voltage Schmitt-triggered input
VO8	Variable voltage output with 8mA sink and 8mA source
VOD8	Variable voltage open-drain output with 8mA sink
PU	50uA (typical) internal pull-up. Unless otherwise noted in the pin description, internal pull-ups are always enabled. Note: Internal pull-up resistors prevent unconnected inputs from floating. Do not rely on internal resistors to drive signals external to the device. When connected to a load that must be pulled high, an external resistor must be added.
PD	50uA (typical) internal pull-down. Unless otherwise noted in the pin description, internal pull-downs are always enabled. Note: Internal pull-down resistors prevent unconnected inputs from floating. Do not rely on internal resistors to drive signals external to the device. When connected to a load that must be pulled low, an external resistor must be added.
AI	Analog input
AIO	Analog bi-directional
ICLK	Crystal oscillator input pin
OCLK	Crystal oscillator output pin
P	Power pin

Note: The digital signals are not 5V tolerant. Refer to [Section 5.1, "Absolute Maximum Ratings*,"](#) on [page 63](#) for additional buffer information.

Note 2.3 Sink and source capabilities are dependant on the VDDIO voltage. Refer to [Section 5.1, "Absolute Maximum Ratings*,"](#) on [page 63](#) for additional information.

Chapter 3 Functional Description

This chapter provides functional descriptions of the various device features. These features have been categorized into the following sections:

- Transceiver
- Auto-negotiation
- HP Auto-MDIX Support
- MAC Interface
- Serial Management Interface (SMI)
- Interrupt Management
- Configuration Straps
- Miscellaneous Functions
- Application Diagrams

3.1 Transceiver

3.1.1 100BASE-TX Transmit

The 100BASE-TX transmit data path is shown in [Figure 3.1](#). Each major block is explained in the following subsections.

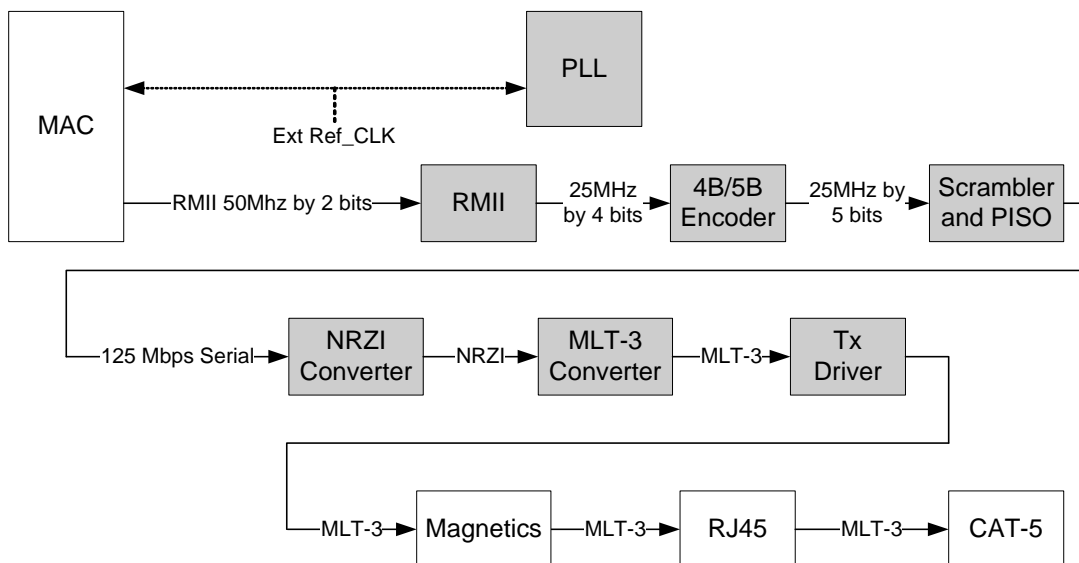

Figure 3.1 100BASE-TX Transmit Data Path

3.1.1.1 100BASE-TX Transmit Data Across the RMII Interface

The MAC controller drives the transmit data onto the TXD bus and asserts TXEN to indicate valid data. The data is latched by the transceiver's RMII block on the rising edge of REF_CLK. The data is in the form of 2-bit wide 50MHz data.

Datasheet

3.1.1.2 4B/5B Encoding

The transmit data passes from the RMII block to the 4B/5B encoder. This block encodes the data from 4-bit nibbles to 5-bit symbols (known as “code-groups”) according to [Table 3.1](#). Each 4-bit data-nibble is mapped to 16 of the 32 possible code-groups. The remaining 16 code-groups are either used for control information or are not valid.

The first 16 code-groups are referred to by the hexadecimal values of their corresponding data nibbles, 0 through F. The remaining code-groups are given letter designations with slashes on either side. For example, an IDLE code-group is /I/, a transmit error code-group is /H/, etc.

Table 3.1 4B/5B Code Table

CODE GROUP	SYM	RECEIVER INTERPRETATION			TRANSMITTER INTERPRETATION		
11110	0	0	0000	DATA	0	0000	DATA
01001	1	1	0001		1	0001	
10100	2	2	0010		2	0010	
10101	3	3	0011		3	0011	
01010	4	4	0100		4	0100	
01011	5	5	0101		5	0101	
01110	6	6	0110		6	0110	
01111	7	7	0111		7	0111	
10010	8	8	1000		8	1000	
10011	9	9	1001		9	1001	
10110	A	A	1010		A	1010	
10111	B	B	1011		B	1011	
11010	C	C	1100		C	1100	
11011	D	D	1101		D	1101	
11100	E	E	1110		E	1110	
11101	F	F	1111		F	1111	
11111	I	IDLE			Sent after /T/R until TXEN		
11000	J	First nibble of SSD, translated to “0101” following IDLE, else RXER			Sent for rising TXEN		
10001	K	Second nibble of SSD, translated to “0101” following J, else RXER			Sent for rising TXEN		
01101	T	First nibble of ESD, causes de-assertion of CRS if followed by /R/, else assertion of RXER			Sent for falling TXEN		
00111	R	Second nibble of ESD, causes deassertion of CRS if following /T/, else assertion of RXER			Sent for falling TXEN		
00100	H	Transmit Error Symbol			Sent for rising TXER		
00110	V	INVALID, RXER if during RXDV			INVALID		

Table 3.1 4B/5B Code Table (continued)

CODE GROUP	SYM	RECEIVER INTERPRETATION	TRANSMITTER INTERPRETATION
11001	V	INVALID, RXER if during RXDV	INVALID
00000	V	INVALID, RXER if during RXDV	INVALID
00001	V	INVALID, RXER if during RXDV	INVALID
00010	V	INVALID, RXER if during RXDV	INVALID
00011	V	INVALID, RXER if during RXDV	INVALID
00101	V	INVALID, RXER if during RXDV	INVALID
01000	V	INVALID, RXER if during RXDV	INVALID
01100	V	INVALID, RXER if during RXDV	INVALID
10000	V	INVALID, RXER if during RXDV	INVALID

3.1.1.3 Scrambling

Repeated data patterns (especially the IDLE code-group) can have power spectral densities with large narrow-band peaks. Scrambling the data helps eliminate these peaks and spread the signal power more uniformly over the entire channel bandwidth. This uniform spectral density is required by FCC regulations to prevent excessive EMI from being radiated by the physical wiring.

The seed for the scrambler is generated from the transceiver address, [PHYAD](#), ensuring that in multiple-transceiver applications, such as repeaters or switches, each transceiver will have its own scrambler sequence.

The scrambler also performs the Parallel In Serial Out conversion (PISO) of the data.

3.1.1.4 NRZI and MLT-3 Encoding

The scrambler block passes the 5-bit wide parallel data to the NRZI converter where it becomes a serial 125MHz NRZI data stream. The NRZI is encoded to MLT-3. MLT-3 is a tri-level code where a change in the logic level represents a code bit “1” and the logic output remaining at the same level represents a code bit “0”.

3.1.1.5 100M Transmit Driver

The MLT3 data is then passed to the analog transmitter, which drives the differential MLT-3 signal, on outputs TXP and TXN, to the twisted pair media across a 1:1 ratio isolation transformer. The 10BASE-T and 100BASE-TX signals pass through the same transformer so that common “magnetics” can be used for both. The transmitter drives into the 100Ω impedance of the CAT-5 cable. Cable termination and impedance matching require external components.

3.1.1.6 100M Phase Lock Loop (PLL)

The 100M PLL locks onto reference clock and generates the 125MHz clock used to drive the 125 MHz logic and the 100BASE-TX transmitter.

Datasheet

3.1.2 100BASE-TX Receive

The 100BASE-TX receive data path is shown in Figure 3.2. Each major block is explained in the following subsections.

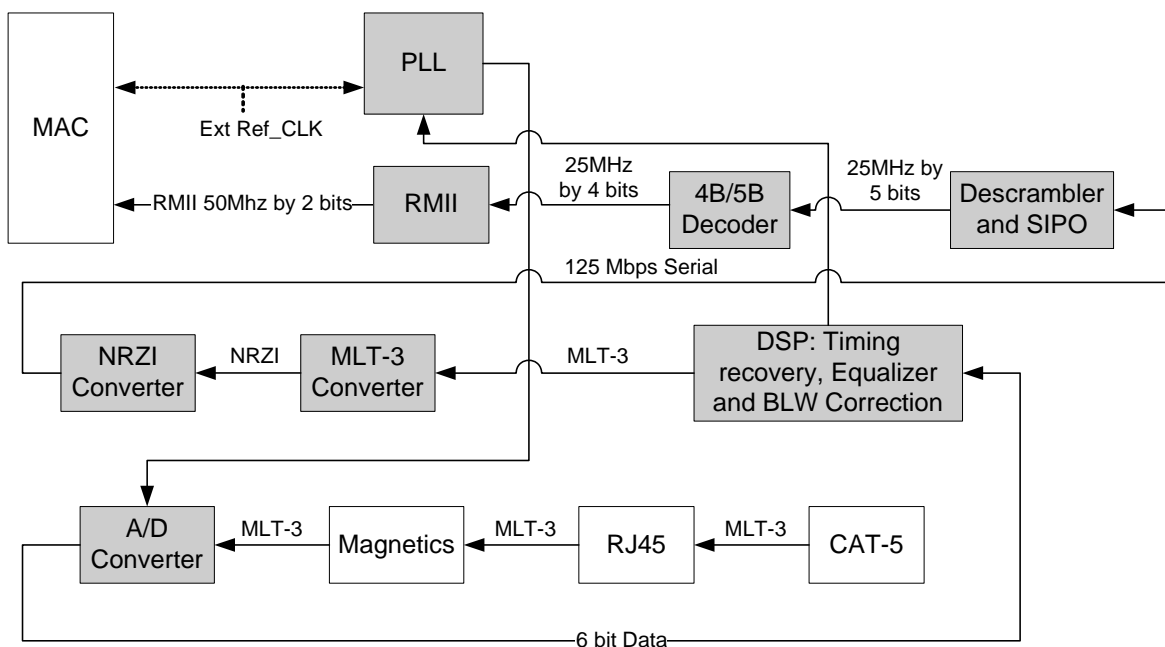

Figure 3.2 100BASE-TX Receive Data Path

3.1.2.1 100M Receive Input

The MLT-3 from the cable is fed into the transceiver (on inputs RXP and RXN) via a 1:1 ratio transformer. The ADC samples the incoming differential signal at a rate of 125M samples per second. Using a 64-level quantizer, it generates 6 digital bits to represent each sample. The DSP adjusts the gain of the ADC according to the observed signal levels such that the full dynamic range of the ADC can be used.

3.1.2.2 Equalizer, Baseline Wander Correction and Clock and Data Recovery

The 6 bits from the ADC are fed into the DSP block. The equalizer in the DSP section compensates for phase and amplitude distortion caused by the physical channel consisting of magnetics, connectors, and CAT-5 cable. The equalizer can restore the signal for any good-quality CAT-5 cable between 1m and 150m.

If the DC content of the signal is such that the low-frequency components fall below the low frequency pole of the isolation transformer, then the droop characteristics of the transformer will become significant and Baseline Wander (BLW) on the received signal will result. To prevent corruption of the received data, the transceiver corrects for BLW and can receive the ANSI X3.263-1995 FDDI TP-PMD defined “killer packet” with no bit errors.

The 100M PLL generates multiple phases of the 125MHz clock. A multiplexer, controlled by the timing unit of the DSP, selects the optimum phase for sampling the data. This is used as the received recovered clock. This clock is used to extract the serial data from the received signal.

3.1.2.3 NRZI and MLT-3 Decoding

The DSP generates the MLT-3 recovered levels that are fed to the MLT-3 converter. The MLT-3 is then converted to an NRZI data stream.

3.1.2.4 Descrambling

The descrambler performs an inverse function to the scrambler in the transmitter and also performs the Serial In Parallel Out (SIPO) conversion of the data.

During reception of IDLE (/I/) symbols, the descrambler synchronizes its descrambler key to the incoming stream. Once synchronization is achieved, the descrambler locks on this key and is able to descramble incoming data.

Special logic in the descrambler ensures synchronization with the remote transceiver by searching for IDLE symbols within a window of 4000 bytes (40us). This window ensures that a maximum packet size of 1514 bytes, allowed by the IEEE 802.3 standard, can be received with no interference. If no IDLE-symbols are detected within this time-period, receive operation is aborted and the descrambler re-starts the synchronization process.

3.1.2.5 Alignment

The de-scrambled signal is then aligned into 5-bit code-groups by recognizing the /J/K/ Start-of-Stream Delimiter (SSD) pair at the start of a packet. Once the code-word alignment is determined, it is stored and utilized until the next start of frame.

3.1.2.6 5B/4B Decoding

The 5-bit code-groups are translated into 4-bit data nibbles according to the 4B/5B table. The translated data is presented on the RXD[1:0] signal lines. The SSD, /J/K/, is translated to "0101 0101" as the first 2 nibbles of the MAC preamble. Reception of the SSD causes the transceiver to assert the receive data valid signal, indicating that valid data is available on the RXD bus. Successive valid code-groups are translated to data nibbles. Reception of either the End of Stream Delimiter (ESD) consisting of the /T/R/ symbols, or at least two /I/ symbols causes the transceiver to de-assert the carrier sense and receive data valid signals.

Note: These symbols are not translated into data.

3.1.2.7 Receive Data Valid Signal

The Receive Data Valid signal (RXDV) indicates that recovered and decoded nibbles are being presented on the RXD[1:0] outputs synchronous to RXCLK. RXDV becomes active after the /J/K/ delimiter has been recognized and RXD is aligned to nibble boundaries. It remains active until either the /T/R/ delimiter is recognized or link test indicates failure or SIGDET becomes false.

RXDV is asserted when the first nibble of translated /J/K/ is ready for transfer over the Media Independent Interface (MII mode).

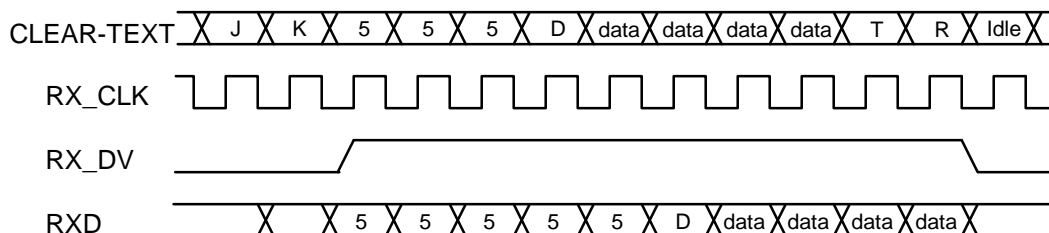

Figure 3.3 Relationship Between Received Data and Specific MII Signals

Datasheet**3.1.2.8 Receiver Errors**

During a frame, unexpected code-groups are considered receive errors. Expected code groups are the DATA set (0 through F), and the /T/R/ (ESD) symbol pair. When a receive error occurs, the RXER signal is asserted and arbitrary data is driven onto the RXD[1:0] lines. Should an error be detected during the time that the /J/K/ delimiter is being decoded (bad SSD error), RXER is asserted true and the value '1110' is driven onto the RXD[1:0] lines. Note that the Valid Data signal is not yet asserted when the bad SSD error occurs.

3.1.2.9 100M Receive Data Across the RMII Interface

The 2-bit data nibbles are sent to the RMII block. These data nibbles are clocked to the controller at a rate of 50MHz. The controller samples the data on the rising edge of XTAL1/CLKIN (REF_CLK). To ensure that the setup and hold requirements are met, the nibbles are clocked out of the transceiver on the falling edge of XTAL1/CLKIN (REF_CLK).

3.1.3 10BASE-T Transmit

Data to be transmitted comes from the MAC layer controller. The 10BASE-T transmitter receives 4-bit nibbles from the MII at a rate of 2.5MHz and converts them to a 10Mbps serial data stream. The data stream is then Manchester-encoded and sent to the analog transmitter, which drives a signal onto the twisted pair via the external magnetics.

The 10M transmitter uses the following blocks:

- MII (digital)
- TX 10M (digital)
- 10M Transmitter (analog)
- 10M PLL (analog)

3.1.3.1 10M Transmit Data Across the RMII Interface

The MAC controller drives the transmit data onto the TXD bus. TXD[1:0] shall transition synchronously with respect to REF_CLK. When TXEN is asserted, TXD[1:0] are accepted for transmission by the device. TXD[1:0] shall be "00" to indicate idle when TXEN is deasserted. Values of TXD[1:0] other than "00" when TXEN is deasserted are reserved for out-of-band signalling (to be defined). Values other than "00" on TXD[1:0] while TXEN is deasserted shall be ignored by the device. TXD[1:0] shall provide valid data for each REF_CLK period while TXEN is asserted.

In order to comply with legacy 10BASE-T MAC/Controllers, in half-duplex mode the transceiver loops back the transmitted data, on the receive path. This does not confuse the MAC/Controller since the COL signal is not asserted during this time. The transceiver also supports the SQE (Heartbeat) signal.

3.1.3.2 Manchester Encoding

The 4-bit wide data is sent to the 10M TX block. The nibbles are converted to a 10Mbps serial NRZI data stream. The 10M PLL locks onto the external clock or internal oscillator and produces a 20MHz clock. This is used to Manchester encode the NRZ data stream. When no data is being transmitted (TXEN is low), the 10M TX block outputs Normal Link Pulses (NLPs) to maintain communications with the remote link partner.

3.1.3.3 10M Transmit Drivers

The Manchester encoded data is sent to the analog transmitter where it is shaped and filtered before being driven out as a differential signal across the TXP and TXN outputs.

3.1.4 10BASE-T Receive

The 10BASE-T receiver gets the Manchester- encoded analog signal from the cable via the magnetics. It recovers the receive clock from the signal and uses this clock to recover the NRZI data stream. This 10M serial data is converted to 4-bit data nibbles which are passed to the controller via MII at a rate of 2.5MHz.

This 10M receiver uses the following blocks:

- Filter and SQUELCH (analog)
- 10M PLL (analog)
- RX 10M (digital)
- MII (digital)

3.1.4.1 10M Receive Input and Squelch

The Manchester signal from the cable is fed into the transceiver (on inputs RXP and RXN) via 1:1 ratio magnetics. It is first filtered to reduce any out-of-band noise. It then passes through a SQUELCH circuit. The SQUELCH is a set of amplitude and timing comparators that normally reject differential voltage levels below 300mV and detect and recognize differential voltages above 585mV.

3.1.4.2 Manchester Decoding

The output of the SQUELCH goes to the 10M RX block where it is validated as Manchester encoded data. The polarity of the signal is also checked. If the polarity is reversed (local RXP is connected to RXN of the remote partner and vice versa), the condition is identified and corrected. The reversed condition is indicated by the **XPOL** bit of the [Special Control/Status Indications Register](#). The 10M PLL is locked onto the received Manchester signal, from which the 20MHz clock is generated. Using this clock, the Manchester encoded data is extracted and converted to a 10MHz NRZI data stream. It is then converted from serial to 4-bit wide parallel data.

The 10M RX block also detects valid 10Base-T IDLE signals - Normal Link Pulses (NLPs) - to maintain the link.

3.1.4.3 10M Receive Data Across the RMII Interface

The 2-bit data nibbles are sent to the RMII block. These data nibbles are valid on the rising edge of the RMII REF_CLK.

3.1.4.4 Jabber Detection

Jabber is a condition in which a station transmits for a period of time longer than the maximum permissible packet length, usually due to a fault condition, which results in holding the TXEN input for a long period. Special logic is used to detect the jabber state and abort the transmission to the line within 45ms. Once TXEN is deasserted, the logic resets the jabber condition.

As shown in [Section 4.2.2, "Basic Status Register," on page 50](#), the **Jabber Detect** bit indicates that a jabber condition was detected.

3.2 Auto-negotiation

The purpose of the auto-negotiation function is to automatically configure the transceiver to the optimum link parameters based on the capabilities of its link partner. Auto-negotiation is a mechanism for exchanging configuration information between two link-partners and automatically selecting the highest performance mode of operation supported by both sides. Auto-negotiation is fully defined in clause 28 of the IEEE 802.3 specification.

Once auto-negotiation has completed, information about the resolved link can be passed back to the controller via the Serial Management Interface (SMI). The results of the negotiation process are

Datasheet

reflected in the [Speed Indication](#) bits of the [PHY Special Control/Status Register](#), as well as in the [Auto Negotiation Link Partner Ability Register](#). The auto-negotiation protocol is a purely physical layer activity and proceeds independently of the MAC controller.

The advertised capabilities of the transceiver are stored in the [Auto Negotiation Advertisement Register](#). The default advertised by the transceiver is determined by user-defined on-chip signal options.

The following blocks are activated during an Auto-negotiation session:

- Auto-negotiation (digital)
- 100M ADC (analog)
- 100M PLL (analog)
- 100M equalizer/BLW/clock recovery (DSP)
- 10M SQUELCH (analog)
- 10M PLL (analog)
- 10M Transmitter (analog)

When enabled, auto-negotiation is started by the occurrence of one of the following events:

- Hardware reset
- Software reset
- Power-down reset
- Link status down
- Setting the [Restart Auto-Negotiate](#) bit of the [Basic Control Register](#)

On detection of one of these events, the transceiver begins auto-negotiation by transmitting bursts of Fast Link Pulses (FLP), which are bursts of link pulses from the 10M transmitter. They are shaped as Normal Link Pulses and can pass uncorrupted down CAT-3 or CAT-5 cable. A Fast Link Pulse Burst consists of up to 33 pulses. The 17 odd-numbered pulses, which are always present, frame the FLP burst. The 16 even-numbered pulses, which may be present or absent, contain the data word being transmitted. Presence of a data pulse represents a "1", while absence represents a "0".

The data transmitted by an FLP burst is known as a "Link Code Word." These are defined fully in IEEE 802.3 clause 28. In summary, the transceiver advertises 802.3 compliance in its selector field (the first 5 bits of the Link Code Word). It advertises its technology ability according to the bits set in the [Auto Negotiation Advertisement Register](#).

There are 4 possible matches of the technology abilities. In the order of priority these are:

- 100M Full Duplex (Highest Priority)
- 100M Half Duplex
- 10M Full Duplex
- 10M Half Duplex (Lowest Priority)

If the full capabilities of the transceiver are advertised (100M, Full Duplex), and if the link partner is capable of 10M and 100M, then auto-negotiation selects 100M as the highest performance mode. If the link partner is capable of half and full duplex modes, then auto-negotiation selects full duplex as the highest performance operation.

Once a capability match has been determined, the link code words are repeated with the acknowledge bit set. Any difference in the main content of the link code words at this time will cause auto-negotiation to re-start. Auto-negotiation will also re-start if not all of the required FLP bursts are received.

The capabilities advertised during auto-negotiation by the transceiver are initially determined by the logic levels latched on the MODE[2:0] configuration straps after reset completes. These configuration straps can also be used to disable auto-negotiation on power-up. Refer to [Section 3.7.2, "MODE\[2:0\]: Mode Configuration," on page 31](#) for additional information.

Writing the bits 8 through 5 of the [Auto Negotiation Advertisement Register](#) allows software control of the capabilities advertised by the transceiver. Writing the [Auto Negotiation Advertisement Register](#) does not automatically re-start auto-negotiation. The [Restart Auto-Negotiate](#) bit of the [Basic Control Register](#) must be set before the new abilities will be advertised. Auto-negotiation can also be disabled via software by clearing the [Auto-Negotiation Enable](#) bit of the [Basic Control Register](#).

Note: The device does not support “Next Page” capability.

3.2.1 Parallel Detection

If the LAN8720A/LAN8720Ai is connected to a device lacking the ability to auto-negotiate (i.e. no FLPs are detected), it is able to determine the speed of the link based on either 100M MLT-3 symbols or 10M Normal Link Pulses. In this case the link is presumed to be half duplex per the IEEE standard. This ability is known as “Parallel Detection.” This feature ensures interoperability with legacy link partners. If a link is formed via parallel detection, then the [Link Partner Auto-Negotiation Able](#) bit of the [Auto Negotiation Expansion Register](#) is cleared to indicate that the Link Partner is not capable of auto-negotiation. The controller has access to this information via the management interface. If a fault occurs during parallel detection, the [Parallel Detection Fault](#) bit of [Link Partner Auto-Negotiation Able](#) is set.

[Auto Negotiation Link Partner Ability Register](#) is used to store the link partner ability information, which is coded in the received FLPs. If the link partner is not auto-negotiation capable, then the [Auto Negotiation Link Partner Ability Register](#) is updated after completion of parallel detection to reflect the speed capability of the link partner.

3.2.2 Restarting Auto-negotiation

Auto-negotiation can be restarted at any time by setting the [Restart Auto-Negotiate](#) bit of the [Basic Control Register](#). Auto-negotiation will also restart if the link is broken at any time. A broken link is caused by signal loss. This may occur because of a cable break, or because of an interruption in the signal transmitted by the link partner. Auto-negotiation resumes in an attempt to determine the new link configuration.

If the management entity re-starts auto-negotiation by setting the [Restart Auto-Negotiate](#) bit of the [Basic Control Register](#), the LAN8720A/LAN8720Ai will respond by stopping all transmission/receiving operations. Once the [break_link_timer](#) is completed in the Auto-negotiation state-machine (approximately 1200ms), auto-negotiation will re-start. In this case, the link partner will have also dropped the link due to lack of a received signal, so it too will resume auto-negotiation.

3.2.3 Disabling Auto-negotiation

Auto-negotiation can be disabled by setting the [Auto-Negotiation Enable](#) bit of the [Basic Control Register](#) to zero. The device will then force its speed of operation to reflect the information in the [Basic Control Register](#) ([Speed Select](#) bit and [Duplex Mode](#) bit). These bits should be ignored when auto-negotiation is enabled.

3.2.4 Half vs. Full Duplex

Half duplex operation relies on the CSMA/CD (Carrier Sense Multiple Access / Collision Detect) protocol to handle network traffic and collisions. In this mode, the carrier sense signal, CRS, responds to both transmit and receive activity. If data is received while the transceiver is transmitting, a collision results.

In full duplex mode, the transceiver is able to transmit and receive data simultaneously. In this mode, CRS responds only to receive activity. The CSMA/CD protocol does not apply and collision detection is disabled.

Datasheet

3.3 HP Auto-MDIX Support

HP Auto-MDIX facilitates the use of CAT-3 (10BASE-T) or CAT-5 (100BASE-T) media UTP interconnect cable without consideration of interface wiring scheme. If a user plugs in either a direct connect LAN cable, or a cross-over patch cable, as shown in [Figure 3.4](#), the device's Auto-MDIX transceiver is capable of configuring the TXP/TXN and RXP/RXN pins for correct transceiver operation.

The internal logic of the device detects the TX and RX pins of the connecting device. Since the RX and TX line pairs are interchangeable, special PCB design considerations are needed to accommodate the symmetrical magnetics and termination of an Auto-MDIX design.

The Auto-MDIX function can be disabled via the [AMDIXCTRL](#) bit in the [Special Control/Status Indications Register](#).

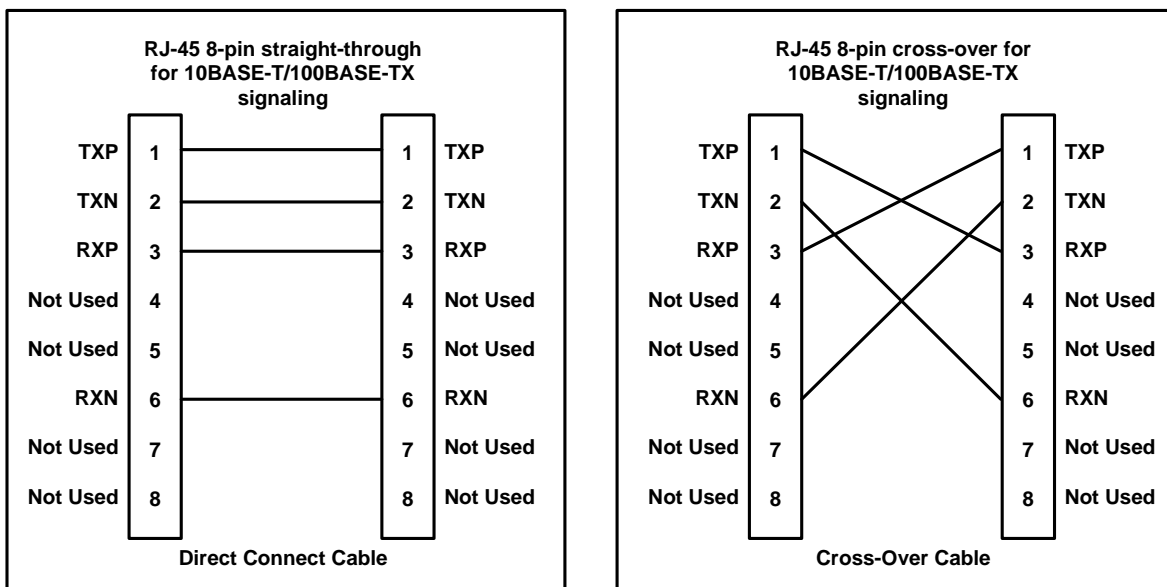

Figure 3.4 Direct Cable Connection vs. Cross-over Cable Connection

3.4 MAC Interface

3.4.1 RMII

The device supports the low pin count Reduced Media Independent Interface (RMII) intended for use between Ethernet transceivers and switch ASICs. Under IEEE 802.3, an MII comprised of 16 pins for data and control is defined. In devices incorporating many MACs or transceiver interfaces such as switches, the number of pins can add significant cost as the port counts increase. RMII reduces this pin count while retaining a management interface (MDIO/MDC) that is identical to MII.

The RMII interface has the following characteristics:

- It is capable of supporting 10Mbps and 100Mbps data rates
- A single clock reference is used for both transmit and receive
- It provides independent 2-bit (di-bit) wide transmit and receive data paths
- It uses LVCMOS signal levels, compatible with common digital CMOS ASIC processes

The RMII includes the following interface signals (1 optional):

- transmit data - TXD[1:0]
- transmit strobe - TXEN
- receive data - RXD[1:0]
- receive error - RXER (Optional)
- carrier sense - CRS_DV
- Reference Clock - (RMII references usually define this signal as REF_CLK)

3.4.1.1 CRS_DV - Carrier Sense/Receive Data Valid

The CRS_DV is asserted by the device when the receive medium is non-idle. CRS_DV is asserted asynchronously on detection of carrier due to the criteria relevant to the operating mode. In 10BASE-T mode when squelch is passed, or in 100BASE-X mode when 2 non-contiguous zeroes in 10 bits are detected, the carrier is said to be detected.

Loss of carrier shall result in the deassertion of CRS_DV synchronous to the cycle of REF_CLK which presents the first di-bit of a nibble onto RXD[1:0] (i.e. CRS_DV is deasserted only on nibble boundaries). If the device has additional bits to be presented on RXD[1:0] following the initial deassertion of CRS_DV, then the device shall assert CRS_DV on cycles of REF_CLK which present the second di-bit of each nibble and de-assert CRS_DV on cycles of REF_CLK which present the first di-bit of a nibble. The result is, starting on nibble boundaries, CRS_DV toggles at 25 MHz in 100Mbps mode and 2.5 MHz in 10Mbps mode when CRS ends before RXDV (i.e. the FIFO still has bits to transfer when the carrier event ends). Therefore, the MAC can accurately recover RXDV and CRS.

During a false carrier event, CRS_DV shall remain asserted for the duration of carrier activity. The data on RXD[1:0] is considered valid once CRS_DV is asserted. However, since the assertion of CRS_DV is asynchronous relative to REF_CLK, the data on RXD[1:0] shall be "00" until proper receive signal decoding takes place.

3.4.1.2 Reference Clock (REF_CLK)

The RMII REF_CLK is a continuous clock that provides the timing reference for CRS_DV, RXD[1:0], TXEN, TXD[1:0] and RXER. The device uses REF_CLK as the network clock such that no buffering is required on the transmit data path. However, on the receive data path, the receiver recovers the clock from the incoming data stream, and the device uses elasticity buffering to accommodate for differences between the recovered clock and the local REF_CLK.

Datasheet

3.5 Serial Management Interface (SMI)

The Serial Management Interface is used to control the device and obtain its status. This interface supports registers 0 through 6 as required by Clause 22 of the 802.3 standard, as well as “vendor-specific” registers 16 to 31 allowed by the specification. Non-supported registers (such as 7 to 15) will be read as hexadecimal “FFFF”. Device registers are detailed in [Chapter 4, "Register Descriptions,"](#) on page 47.

At the system level, SMI provides 2 signals: MDIO and MDC. The MDC signal is an aperiodic clock provided by the station management controller (SMC). MDIO is a bi-directional data SMI input/output signal that receives serial data (commands) from the controller SMC and sends serial data (status) to the SMC. The minimum time between edges of the MDC is 160 ns. There is no maximum time between edges. The minimum cycle time (time between two consecutive rising or two consecutive falling edges) is 400 ns. These modest timing requirements allow this interface to be easily driven by the I/O port of a microcontroller.

The data on the MDIO line is latched on the rising edge of the MDC. The frame structure and timing of the data is shown in [Figure 3.5](#) and [Figure 3.6](#). The timing relationships of the MDIO signals are further described in [Section 5.5.5, "SMI Timing,"](#) on page 73.

Read Cycle

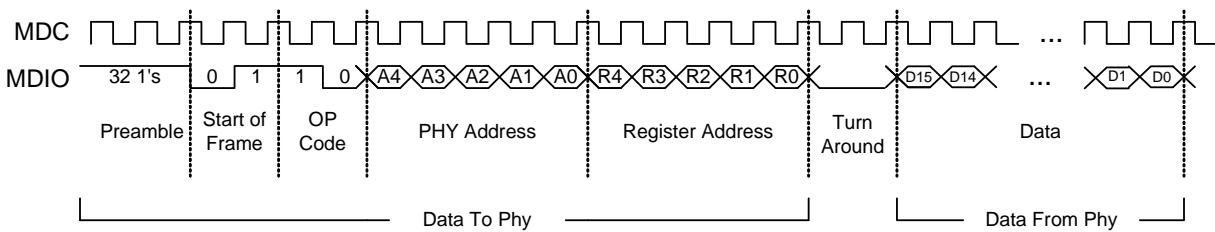

Figure 3.5 MDIO Timing and Frame Structure - READ Cycle

Write Cycle

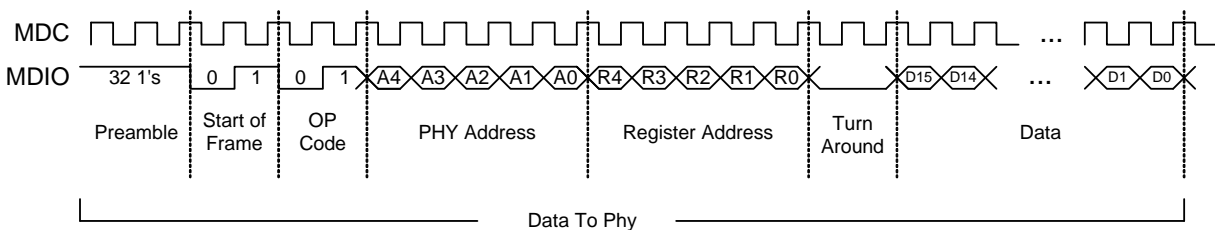

Figure 3.6 MDIO Timing and Frame Structure - WRITE Cycle

3.6 Interrupt Management

The device management interface supports an interrupt capability that is not a part of the IEEE 802.3 specification. This interrupt capability generates an active low asynchronous interrupt signal on the nINT output whenever certain events are detected as setup by the [Interrupt Mask Register](#).

The device's interrupt system provides two modes, a Primary Interrupt mode and an Alternative interrupt mode. Both systems will assert the nINT pin low when the corresponding mask bit is set. These modes differ only in how they de-assert the nINT interrupt output. These modes are detailed in the following subsections.

Note: The Primary interrupt mode is the default interrupt mode after a power-up or hard reset. The Alternative interrupt mode requires setup after a power-up or hard reset.

3.6.1 Primary Interrupt System

The Primary interrupt system is the default interrupt mode ([ALTINT](#) bit of the [Mode Control/Status Register](#) is "0"). The Primary interrupt system is always selected after power-up or hard reset. In this mode, to set an interrupt, set the corresponding mask bit in the [Interrupt Mask Register](#) (see [Table 3.2](#)). Then when the event to assert nINT is true, the nINT output will be asserted. When the corresponding event to deassert nINT is true, then the nINT will be de-asserted.

Table 3.2 Interrupt Management Table

MASK	INTERRUPT SOURCE FLAG		INTERRUPT SOURCE		EVENT TO ASSERT nINT	EVENT TO DE-ASSERT nINT
30.7	29.7	ENERGYON	17.1	ENERGYON	Rising 17.1 (Note 3.1)	Falling 17.1 or Reading register 29
30.6	29.6	Auto-Negotiation complete	1.5	Auto-Negotiate Complete	Rising 1.5	Falling 1.5 or Reading register 29
30.5	29.5	Remote Fault Detected	1.4	Remote Fault	Rising 1.4	Falling 1.4, or Reading register 1 or Reading register 29
30.4	29.4	Link Down	1.2	Link Status	Falling 1.2	Reading register 1 or Reading register 29
30.3	29.3	Auto-Negotiation LP Acknowledge	5.14	Acknowledge	Rising 5.14	Falling 5.14 or Read register 29
30.2	29.2	Parallel Detection Fault	6.4	Parallel Detection Fault	Rising 6.4	Falling 6.4 or Reading register 6, or Reading register 29 or Re-Auto Negotiate or Link down
30.1	29.1	Auto-Negotiation Page Received	6.1	Page Received	Rising 6.1	Falling of 6.1 or Reading register 6, or Reading register 29 Re-Auto Negotiate, or Link Down.

Note 3.1 If the mask bit is enabled and nINT has been de-asserted while ENERGYON is still high, nINT will assert for 256 ms, approximately one second after ENERGYON goes low when the Cable is unplugged. To prevent an unexpected assertion of nINT, the ENERGYON interrupt mask should always be cleared as part of the ENERGYON interrupt service routine.

Datasheet

Note: The **ENERGYON** bit in the **Mode Control/Status Register** is defaulted to a '1' at the start of the signal acquisition process, therefore the **INT7** bit in the **Interrupt Mask Register** will also read as a '1' at power-up. If no signal is present, then both **ENERGYON** and **INT7** will clear within a few milliseconds.

3.6.2 Alternate Interrupt System

The Alternate interrupt system is enabled by setting the **ALTINT** bit of the **Mode Control/Status Register** to "1". In this mode, to set an interrupt, set the corresponding bit of the in the Mask Register 30, (see [Table 3.3](#)). To Clear an interrupt, either clear the corresponding bit in the **Interrupt Mask Register** to deassert the **nINT** output, or clear the interrupt source, and write a '1' to the corresponding Interrupt Source Flag. Writing a '1' to the Interrupt Source Flag will cause the state machine to check the Interrupt Source to determine if the Interrupt Source Flag should clear or stay as a '1'. If the Condition to deassert is true, then the Interrupt Source Flag is cleared and **nINT** is also deasserted. If the Condition to deassert is false, then the Interrupt Source Flag remains set, and the **nINT** remains asserted.

For example, setting the **INT7** bit in the **Interrupt Mask Register** will enable the **ENERGYON** interrupt. After a cable is plugged in, the **ENERGYON** bit in the **Mode Control/Status Register** goes active and **nINT** will be asserted low. To de-assert the **nINT** interrupt output, either clear the **ENERGYON** bit in the **Mode Control/Status Register** by removing the cable and then writing a '1' to the **INT7** bit in the **Interrupt Mask Register**, OR clear the **INT7** mask (bit 7 of the **Interrupt Mask Register**).

Table 3.3 Alternative Interrupt System Management Table

MASK	INTERRUPT SOURCE FLAG		INTERRUPT SOURCE		EVENT TO ASSERT nINT	CONDITION TO DE-ASSERT	BIT TO CLEAR nINT
30.7	29.7	ENERGYON	17.1	ENERGYON	Rising 17.1	17.1 low	29.7
30.6	29.6	Auto-Negotiation complete	1.5	Auto-Negotiate Complete	Rising 1.5	1.5 low	29.6
30.5	29.5	Remote Fault Detected	1.4	Remote Fault	Rising 1.4	1.4 low	29.5
30.4	29.4	Link Down	1.2	Link Status	Falling 1.2	1.2 high	29.4
30.3	29.3	Auto-Negotiation LP Acknowledge	5.14	Acknowledge	Rising 5.14	5.14 low	29.3
30.2	29.2	Parallel Detection Fault	6.4	Parallel Detection Fault	Rising 6.4	6.4 low	29.2
30.1	29.1	Auto-Negotiation Page Received	6.1	Page Received	Rising 6.1	6.1 low	29.1

Note: The **ENERGYON** bit in the **Mode Control/Status Register** is defaulted to a '1' at the start of the signal acquisition process, therefore the **INT7** bit in the **Interrupt Mask Register** will also read as a '1' at power-up. If no signal is present, then both **ENERGYON** and **INT7** will clear within a few milliseconds.

3.7 Configuration Straps

Configuration straps allow various features of the device to be automatically configured to user defined values. Configuration straps are latched upon Power-On Reset (POR) and pin reset (nRST). Configuration straps include internal resistors in order to prevent the signal from floating when unconnected. If a particular configuration strap is connected to a load, an external pull-up or pull-down resistor should be used to augment the internal resistor to ensure that it reaches the required voltage level prior to latching. The internal resistor can also be overridden by the addition of an external resistor.

Note: The system designer must guarantee that configuration strap pins meet the timing requirements specified in [Section 5.5.3, "Power-On nRST & Configuration Strap Timing," on page 70](#). If configuration strap pins are not at the correct voltage level prior to being latched, the device may capture incorrect strap values.

Note: When externally pulling configuration straps high, the strap should be tied to VDDIO, except for [REGOFF](#) and [nINTSEL](#) which should be tied to VDD2A.

3.7.1 PHYAD[0]: PHY Address Configuration

The PHYAD0 bit is driven high or low to give each PHY a unique address. This address is latched into an internal register at the end of a hardware reset (default = 0b). In a multi-PHY application (such as a repeater), the controller is able to manage each PHY via the unique address. Each PHY checks each management data frame for a matching address in the relevant bits. When a match is recognized, the PHY responds to that particular frame. The PHY address is also used to seed the scrambler. In a multi-PHY application, this ensures that the scramblers are out of synchronization and disperses the electromagnetic radiation across the frequency spectrum.

The device's SMI address may be configured using hardware configuration to either the value 0 or 1. The user can configure the PHY address using Software Configuration if an address greater than 1 is required. The PHY address can be written (after SMI communication at some address is established) using the [PHYAD](#) bits of the [Special Modes Register](#). The [PHYAD0](#) hardware configuration strap is multiplexed with the RXER pin.

3.7.2 MODE[2:0]: Mode Configuration

The [MODE\[2:0\]](#) configuration straps control the configuration of the 10/100 digital block. When the nRST pin is deasserted, the register bit values are loaded according to the [MODE\[2:0\]](#) configuration straps. The 10/100 digital block is then configured by the register bit values. When a soft reset occurs via the [Soft Reset](#) bit of the [Basic Control Register](#), the configuration of the 10/100 digital block is controlled by the register bit values and the [MODE\[2:0\]](#) configuration straps have no affect.

The device's mode may be configured using the hardware configuration straps as summarized in [Table 3.4](#). The user may configure the transceiver mode by writing the SMI registers.

Datasheet

Table 3.4 **MODE[2:0] Bus**

MODE[2:0]	MODE DEFINITIONS	DEFAULT REGISTER BIT VALUES	
		REGISTER 0	REGISTER 4
		[13,12,10,8]	[8,7,6,5]
000	10Base-T Half Duplex. Auto-negotiation disabled.	0000	N/A
001	10Base-T Full Duplex. Auto-negotiation disabled.	0001	N/A
010	100Base-TX Half Duplex. Auto-negotiation disabled. CRS is active during Transmit & Receive.	1000	N/A
011	100Base-TX Full Duplex. Auto-negotiation disabled. CRS is active during Receive.	1001	N/A
100	100Base-TX Half Duplex is advertised. Auto-negotiation enabled. CRS is active during Transmit & Receive.	1100	0100
101	Repeater mode. Auto-negotiation enabled. 100Base-TX Half Duplex is advertised. CRS is active during Receive.	1100	0100
110	Power Down mode. In this mode the transceiver will wake-up in Power-Down mode. The transceiver cannot be used when the MODE[2:0] bits are set to this mode. To exit this mode, the MODE bits in Register 18.7:5(see Section 4.2.9, "Special Modes Register," on page 57) must be configured to some other value and a soft reset must be issued.	N/A	N/A
111	All capable. Auto-negotiation enabled.	X10X	1111

The MODE[2:0] hardware configuration pins are multiplexed with other signals as shown in [Table 3.5](#).

Table 3.5 **Pin Names for Mode Bits**

MODE BIT	PIN NAME
MODE[0]	RXD0/ <u>MODE0</u>
MODE[1]	RXD1/ <u>MODE1</u>
MODE[2]	CRS_DV/ <u>MODE2</u>

3.7.3 **REGOFF: Internal +1.2V Regulator Configuration**

The incorporation of flexPWR technology provides the ability to disable the internal +1.2V regulator. When the regulator is disabled, an external +1.2V must be supplied to the VDDCR pin. Disabling the internal +1.2V regulator makes it possible to reduce total system power, since an external switching regulator with greater efficiency (versus the internal linear regulator) can be used to provide +1.2V to the transceiver circuitry.

Note: Because the **REGOFF** configuration strap shares functionality with the LED1 pin, proper consideration must also be given to the LED polarity. Refer to [Section 3.8.1.1, "REGOFF and LED1 Polarity Selection," on page 37](#) for additional information on the relation between **REGOFF** and the LED1 polarity.

3.7.3.1 Disabling the Internal +1.2V Regulator

To disable the +1.2V internal regulator, a pull-up strapping resistor should be connected from the REGOFF configuration strap to VDD2A. At power-on, after both VDDIO and VDD2A are within specification, the transceiver will sample REGOFF to determine whether the internal regulator should turn on. If the pin is sampled at a voltage greater than V_{IH} , then the internal regulator is disabled and the system must supply +1.2V to the VDDCR pin. The VDDIO voltage must be at least 80% of the operating voltage level (1.44V when operating at 1.8V, 2.0V when operating at 2.5V, 2.64V when operating at 3.3V) before voltage is applied to VDDCR. As described in [Section 3.7.3.2](#), when REGOFF is left floating or connected to VSS, the internal regulator is enabled and the system is not required to supply +1.2V to the VDDCR pin.

3.7.3.2 Enabling the Internal +1.2V Regulator

The +1.2V for VDDCR is supplied by the on-chip regulator unless the transceiver is configured for the regulator off mode using the REGOFF configuration strap as described in [Section 3.7.3.1](#). By default, the internal +1.2V regulator is enabled when REGOFF is floating (due to the internal pull-down resistor). During power-on, if REGOFF is sampled below V_{IL} , then the internal +1.2V regulator will turn on and operate with power from the VDD2A pin.

3.7.4 nINTSEL: nINT/REFCLKO Configuration

The nINTSEL configuration strap is used to select between one of two available modes: REF_CLK In Mode (nINT) and REF_CLK Out Mode. The configured mode determines the function of the nINT/REFCLKO pin. The nINTSEL configuration strap is latched at POR and on the rising edge of the nRST. By default, nINTSEL is configured for nINT mode via the internal pull-up resistor.

Table 3.6 nINTSEL Configuration

STRAP VALUE	MODE	REF_CLK DESCRIPTION
<u>nINTSEL</u> = 0	REF_CLK Out Mode	nINT/REFCLKO is the source of REF_CLK.
<u>nINTSEL</u> = 1	REF_CLK In Mode	nINT/REFCLKO is an active low interrupt output. The REF_CLK is sourced externally and must be driven on the XTAL1/CLKIN pin.

The RMII REF_CLK is a continuous clock that provides the timing reference for CRS_DV, RXD[1:0], TXEN, TXD[1:0] and RXER. The device uses REF_CLK as the network clock such that no buffering is required on the transmit data path. However, on the receive data path, the receiver recovers the clock from the incoming data stream. The device uses elasticity buffering to accommodate for differences between the recovered clock and the local REF_CLK.

In REF_CLK In Mode, the 50MHz REF_CLK is driven on the XTAL1/CLKIN pin. This is the traditional system configuration when using RMII, and is described in [Section 3.7.4.1](#). When configured for REF_CLK Out Mode, the device generates the 50MHz RMII REF_CLK and the nINT interrupt is not available. REF_CLK Out Mode allows a low-cost 25MHz crystal to be used as the reference for REF_CLK. This configuration may result in reduced system cost and is described in [Section 3.7.4.2](#).

Note: Because the nINTSEL configuration strap shares functionality with the LED2 pin, proper consideration must also be given to the LED polarity. Refer to [Section 3.8.1.2, "nINTSEL and LED2 Polarity Selection," on page 37](#) for additional information on the relation between nINTSEL and the LED2 polarity.

Datasheet

3.7.4.1 REF_CLK In Mode

In REF_CLK In Mode, the 50MHz REF_CLK is driven on the XTAL1/CLKIN pin. A 50MHz source for REF_CLK must be available external to the device when using this mode. The clock is driven to both the MAC and PHY as shown in Figure 3.7.

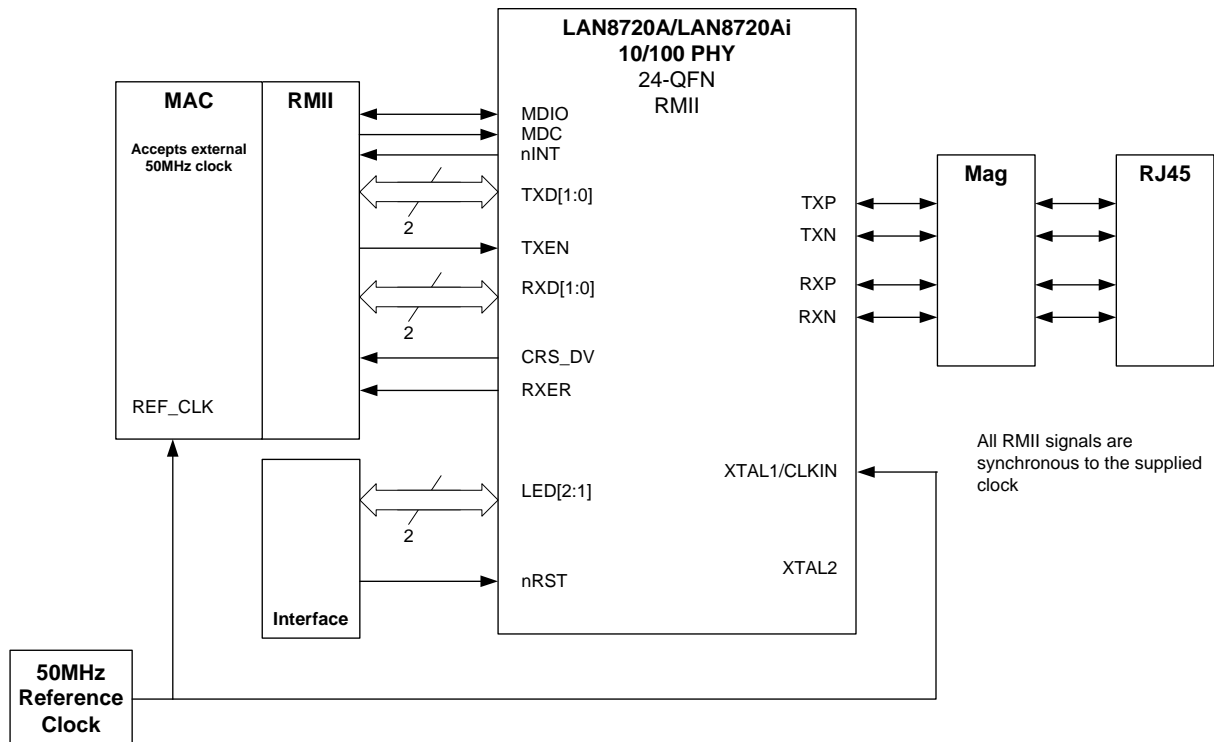

Figure 3.7 External 50MHz clock sources the REF_CLK

3.7.4.2 REF_CLK Out Mode

To reduce BOM cost, the device includes a feature to generate the RMII REF_CLK signal from a low-cost, 25MHz fundamental crystal. This type of crystal is inexpensive in comparison to 3rd overtone crystals that would normally be required for 50MHz. The MAC must be capable of operating with an external clock to take advantage of this feature as shown in Figure 3.8.

In order to optimize package size and cost, the REFCLKO pin is multiplexed with the nINT pin. In REF_CLK Out mode, the nINT functionality is disabled to accommodate usage of REFCLKO as a 50MHz clock to the MAC.

Note: The REF_CLK Out Mode is not part of the RMII Specification. Timing in this mode is not compliant with the RMII specification. To ensure proper system operation, a timing analysis of the MAC and LAN8720 must be performed.

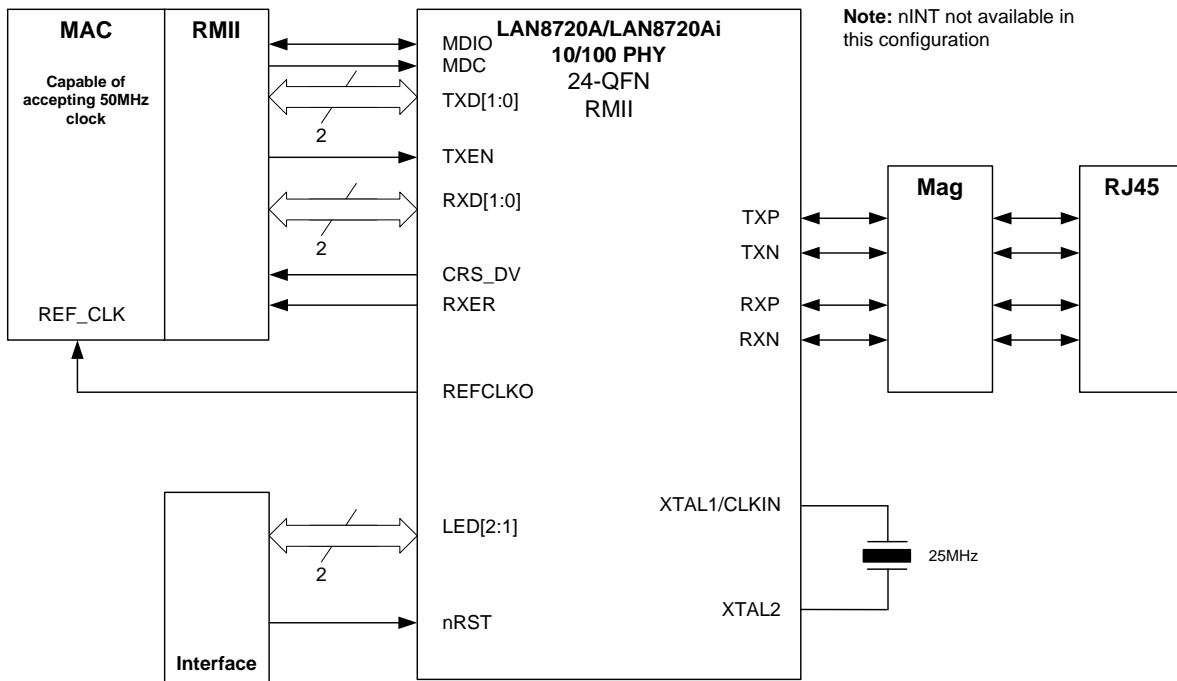

Figure 3.8 Sourcing REF_CLK from a 25MHz Crystal

In some system architectures, a 25MHz clock source is available. The device can be used to generate the REF_CLK to the MAC as shown in Figure 3.9. It is important to note that in this specific example, only a 25MHz clock can be used (clock cannot be 50MHz). Similar to the 25MHz crystal mode, the nINT function is disabled.

Datasheet

Note: nINT is not available in this configuration

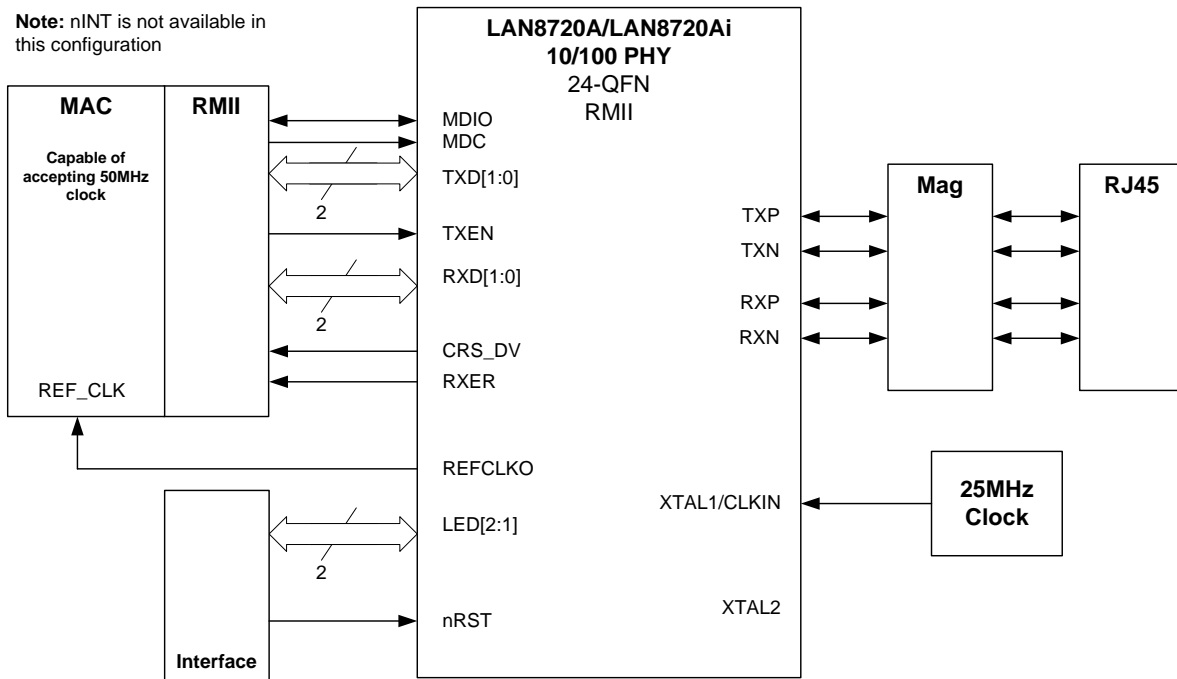

Figure 3.9 Sourcing REF_CLK from External 25MHz Source

3.8 Miscellaneous Functions

3.8.1 LEDs

Two LED signals are provided as a convenient means to determine the transceiver's mode of operation. All LED signals are either active high or active low as described in [Section 3.8.1.2, "nINTSEL and LED2 Polarity Selection"](#) and [Section 3.8.1.1, "REGOFF and LED1 Polarity Selection,"](#) on page 37.

The LED1 output is driven active whenever the device detects a valid link, and blinks when CRS is active (high) indicating activity.

The LED2 output is driven active when the operating speed is 100Mbps. This LED will go inactive when the operating speed is 10Mbps or during line isolation.

Note: When pulling the LED1 and LED2 pins high, they must be tied to VDD2A, **NOT** VDDIO.

3.8.1.1 REGOFF and LED1 Polarity Selection

The REGOFF configuration strap is shared with the LED1 pin. The LED1 output will automatically change polarity based on the presence of an external pull-up resistor. If the LED1 pin is pulled high to VDD2A by an external pull-up resistor to select a logical high for REGOFF, then the LED1 output will be active low. If the LED1 pin is pulled low by the internal pull-down resistor to select a logical low for REGOFF, the LED1 output will then be an active high output. [Figure 3.10](#) details the LED1 polarity for each REGOFF configuration.

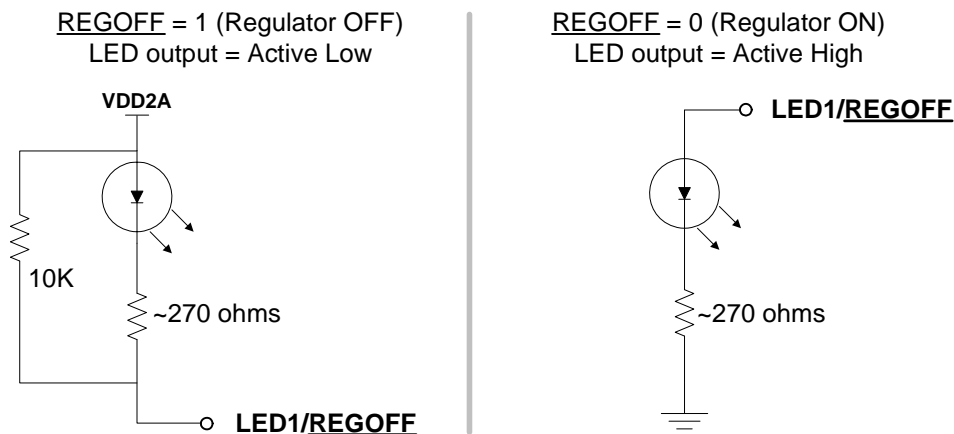

Figure 3.10 LED1/REGOFF Polarity Configuration

Note: Refer to [Section 3.7.3, "REGOFF: Internal +1.2V Regulator Configuration,"](#) on page 32 for additional information on the REGOFF configuration strap.

3.8.1.2 nINTSEL and LED2 Polarity Selection

The nINTSEL configuration strap is shared with the LED2 pin. The LED2 output will automatically change polarity based on the presence of an external pull-down resistor. If the LED2 pin is pulled high to VDD2A to select a logical high for nINTSEL, then the LED2 output will be active low. If the LED2

Datasheet

pin is pulled low by an external pull-down resistor to select a logical low for $\overline{\text{nINTSEL}}$, the LED2 output will then be an active high output. Figure 3.11 details the LED2 polarity for each $\overline{\text{nINTSEL}}$ configuration.

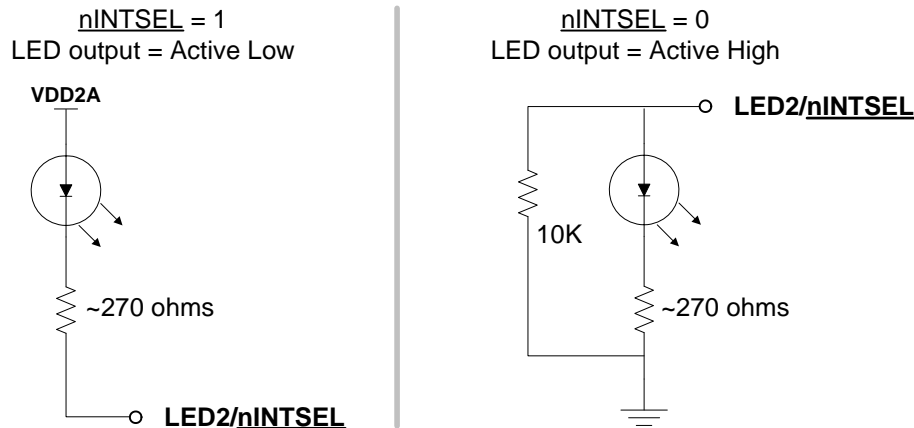

Figure 3.11 LED2/ $\overline{\text{nINTSEL}}$ Polarity Configuration

Note: Refer to Section 3.7.4, "nINTSEL: nINT/REFCLKO Configuration," on page 33 for additional information on the $\overline{\text{nINTSEL}}$ configuration strap.

3.8.2 Variable Voltage I/O

The device's digital I/O pins are variable voltage, allowing them to take advantage of low power savings from shrinking technologies. These pins can operate from a low I/O voltage of +1.62V up to +3.6V. The applied I/O voltage must maintain its value with a tolerance of $\pm 10\%$. Varying the voltage up or down after the transceiver has completed power-on reset can cause errors in the transceiver operation. Refer to Chapter 5, "Operational Characteristics," on page 63 for additional information.

Note: Input signals must not be driven high before power is applied to the device.

3.8.3 Power-Down Modes

There are two device power-down modes: General Power-Down Mode and Energy Detect Power-Down Mode. These modes are described in the following subsections.

3.8.3.1 General Power-Down

This power-down mode is controlled via the **Power Down** bit of the **Basic Control Register**. In this mode, the entire transceiver (except the management interface) is powered-down and remains in this mode as long as the **Power Down** bit is "1". When the **Power Down** bit is cleared, the transceiver powers up and is automatically reset.

3.8.3.2 Energy Detect Power-Down

This power-down mode is activated by setting the **EDPWRDOWN** bit of the **Mode Control/Status Register**. In this mode, when no energy is present on the line the transceiver is powered down (except for the management interface, the SQUELCH circuit, and the ENERGYON logic). The ENERGYON logic is used to detect the presence of valid energy from 100BASE-TX, 10BASE-T, or Auto-negotiation signals.

In this mode, when the **ENERGYON** bit of the **Mode Control/Status Register** is low, the transceiver is powered-down and nothing is transmitted. When energy is received via link pulses or packets, the **ENERGYON** bit goes high and the transceiver powers-up. The device automatically resets into the

state prior to power-down and asserts the nINT interrupt if the ENERGYON interrupt is enabled in the [Interrupt Mask Register](#). The first and possibly the second packet to activate ENERGYON may be lost.

When the [EDPWRDOWN](#) bit of the [Mode Control/Status Register](#) is low, energy detect power-down is disabled.

3.8.4 Isolate Mode

The device data paths may be electrically isolated from the RMII interface by setting the [Isolate](#) bit of the [Basic Control Register](#) to “1”. In isolation mode, the transceiver does not respond to the TXD, TXEN and TXER inputs, but does respond to management transactions.

Isolation provides a means for multiple transceivers to be connected to the same RMII interface without contention. By default, the transceiver is not isolated (on power-up ([Isolate](#)=0)).

3.8.5 Resets

The device provides two forms of reset: Hardware and Software. The device registers are reset by both Hardware and Software resets. Select register bits, indicated as “NASR” in the register definitions, are not cleared by a Software reset. The registers are not reset by the power-down modes described in [Section 3.8.3](#).

Note: For the first 16us after coming out of reset, the RMII interface will run at 2.5 MHz. After this time, it will switch to 25 MHz if auto-negotiation is enabled.

3.8.5.1 Hardware Reset

A Hardware reset is asserted by driving the nRST input pin low. When driven, nRST should be held low for the minimum time detailed in [Section 5.5.3, "Power-On nRST & Configuration Strap Timing," on page 70](#) to ensure a proper transceiver reset. During a Hardware reset, an external clock *must* be supplied to the XTAL1/CLKIN signal.

Note: A hardware reset (nRST assertion) is required following power-up. Refer to [Section 5.5.3, "Power-On nRST & Configuration Strap Timing," on page 70](#) for additional information.

3.8.5.2 Software Reset

A Software reset is activated by setting the [Soft Reset](#) bit of the [Basic Control Register](#) to “1”. All registers bits, except those indicated as “NASR” in the register definitions, are cleared by a Software reset. The [Soft Reset](#) bit is self-clearing. Per the IEEE 802.3u standard, clause 22 (22.2.4.1.1) the reset process will be completed within 0.5s from the setting of this bit.

3.8.6 Carrier Sense

The carrier sense (CRS) is output on the CRS_DV pin. CRS is a signal defined by the MII specification in the IEEE 802.3u standard. The device asserts CRS based only on receive activity whenever the transceiver is either in repeater mode or full-duplex mode. Otherwise the transceiver asserts CRS based on either transmit or receive activity.

The carrier sense logic uses the encoded, unscrambled data to determine carrier activity status. It activates carrier sense with the detection of 2 non-contiguous zeros within any 10 bit span. Carrier sense terminates if a span of 10 consecutive ones is detected before a /J/K/ Start-of Stream Delimiter pair. If an SSD pair is detected, carrier sense is asserted until either /T/R/ End-of-Stream Delimiter pair or a pair of IDLE symbols is detected. Carrier is negated after the /T/ symbol or the first IDLE. If /T/ is not followed by /R/, then carrier is maintained. Carrier is treated similarly for IDLE followed by some non-IDLE symbol.

Datasheet

3.8.7 Link Integrity Test

The device performs the link integrity test as outlined in the IEEE 802.3u (Clause 24-15) Link Monitor state diagram. The link status is multiplexed with the 10Mbps link status to form the [Link Status](#) bit in the [Basic Status Register](#) and to drive the LINK LED (LED1).

The DSP indicates a valid MLT-3 waveform present on the RXP and RXN signals as defined by the ANSI X3.263 TP-PMD standard, to the Link Monitor state-machine, using the internal DATA_VALID signal. When DATA_VALID is asserted, the control logic moves into a Link-Ready state and waits for an enable from the auto-negotiation block. When received, the Link-Up state is entered, and the Transmit and Receive logic blocks become active. Should auto-negotiation be disabled, the link integrity logic moves immediately to the Link-Up state when the DATA_VALID is asserted.

To allow the line to stabilize, the link integrity logic will wait a minimum of 330 μ sec from the time DATA_VALID is asserted until the Link-Ready state is entered. Should the DATA_VALID input be negated at any time, this logic will immediately negate the Link signal and enter the Link-Down state.

When the 10/100 digital block is in 10BASE-T mode, the link status is derived from the 10BASE-T receiver logic.

3.8.8 Loopback Operation

The device may be configured for near-end loopback and far loopback. These loopback modes are detailed in the following subsections.

3.8.8.1 Near-end Loopback

Near-end loopback mode sends the digital transmit data back out the receive data signals for testing purposes, as indicated by the blue arrows in [Figure 3.12](#). The near-end loopback mode is enabled by setting the [Loopback](#) bit of the [Basic Control Register](#) to "1". A large percentage of the digital circuitry is operational in near-end loopback mode because data is routed through the PCS and PMA layers into the PMD sublayer before it is looped back. The transmitters are powered down regardless of the state of TXEN.

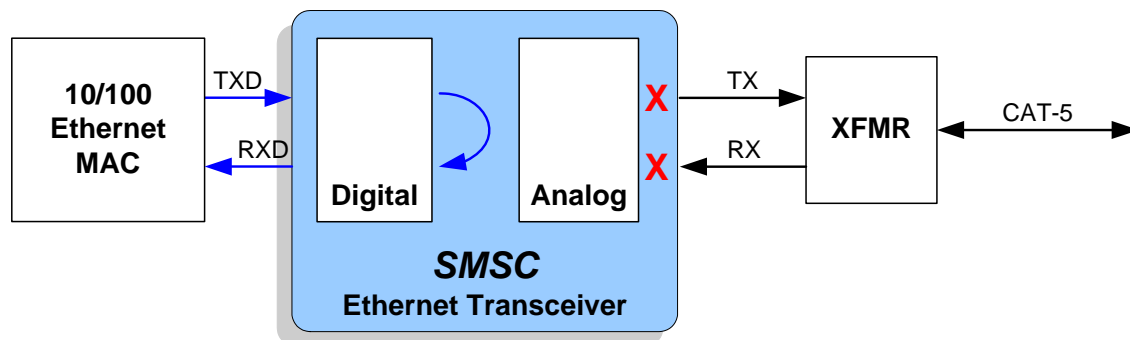

Figure 3.12 Near-end Loopback Block Diagram

3.8.8.2 Far Loopback

Far loopback is a special test mode for MDI (analog) loopback as indicated by the blue arrows in [Figure 3.14](#). The far loopback mode is enabled by setting the [FARLOOPBACK](#) bit of the [Mode Control/Status Register](#) to "1". In this mode, data that is received from the link partner on the MDI is looped back out to the link partner. The digital interface signals on the local MAC interface are isolated.

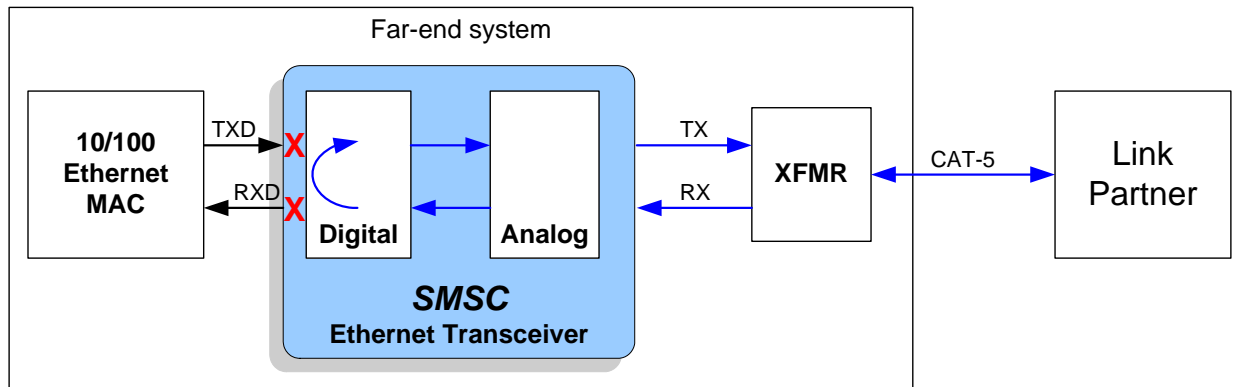

Figure 3.13 Far Loopback Block Diagram

3.8.8.3 Connector Loopback

The device maintains reliable transmission over very short cables, and can be tested in a connector loopback as shown in Figure 3.14. An RJ45 loopback cable can be used to route the transmit signals on the output of the transformer back to the receiver inputs, and this loopback will work at both 10 and 100.

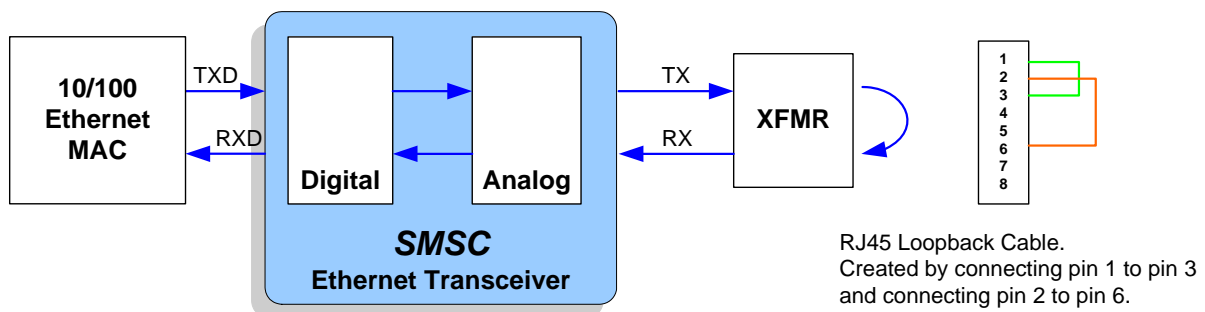

Figure 3.14 Connector Loopback Block Diagram

3.9 Application Diagrams

This section provides typical application diagrams for the following:

- [Simplified System Level Application Diagram](#)
- [Power Supply Diagram \(1.2V Supplied by Internal Regulator\)](#)
- [Power Supply Diagram \(1.2V Supplied by External Source\)](#)
- [Twisted-Pair Interface Diagram \(Single Power Supply\)](#)
- [Twisted-Pair Interface Diagram \(Dual Power Supplies\)](#)

Datasheet

3.9.1 Simplified System Level Application Diagram

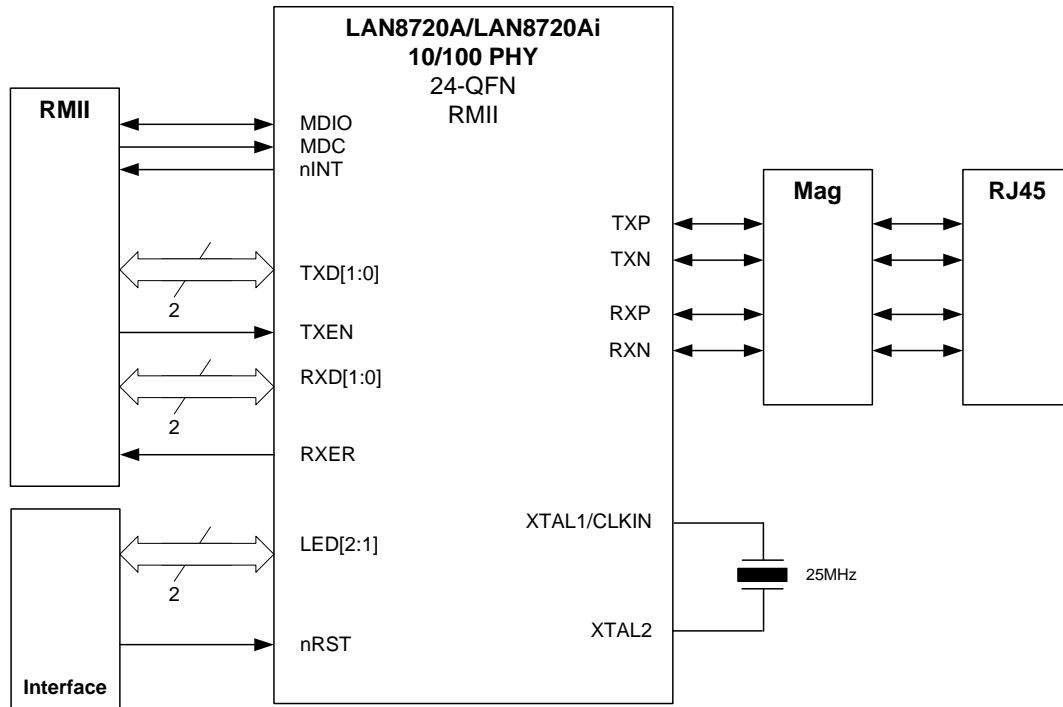

Figure 3.15 Simplified System Level Application Diagram

3.9.2 Power Supply Diagram (1.2V Supplied by Internal Regulator)

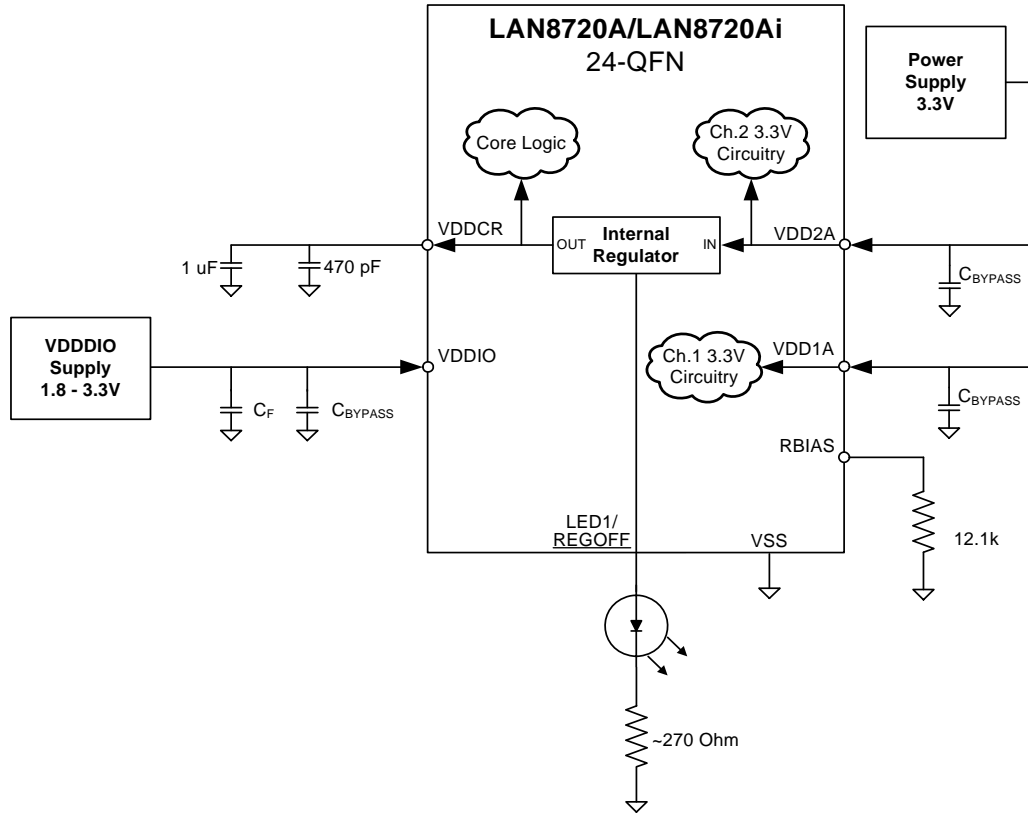

Figure 3.16 Power Supply Diagram (1.2V Supplied by Internal Regulator)

Datasheet

3.9.3 Power Supply Diagram (1.2V Supplied by External Source)

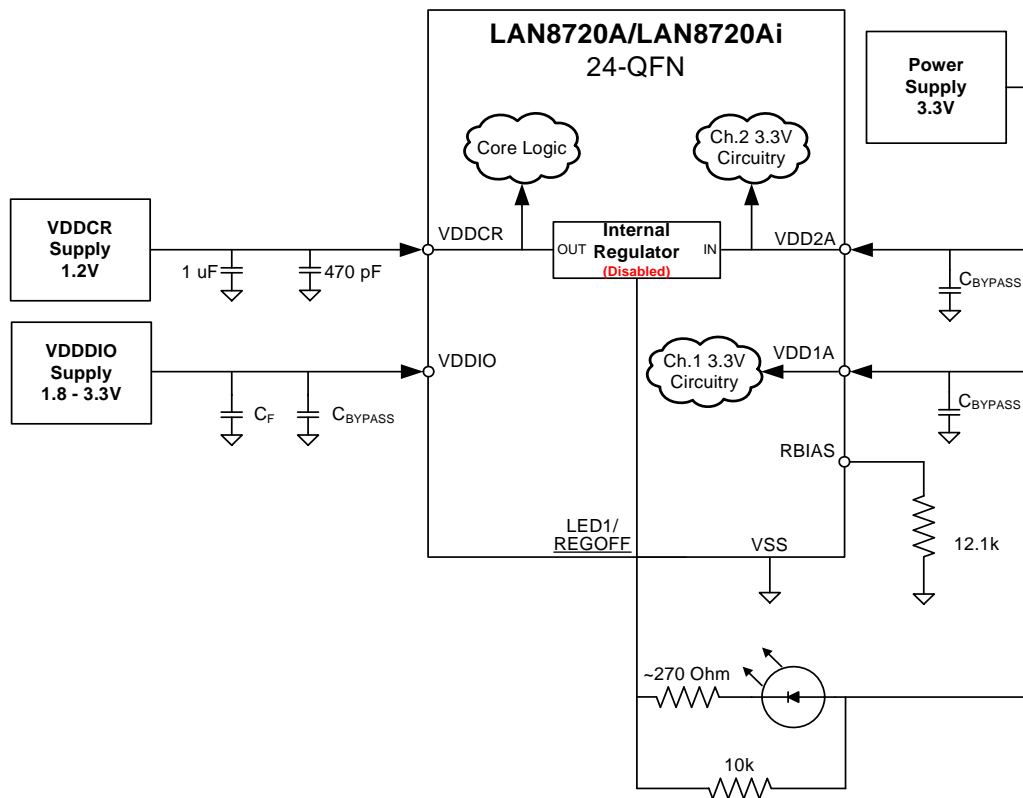

Figure 3.17 Power Supply Diagram (1.2V Supplied by External Source)

3.9.4 Twisted-Pair Interface Diagram (Single Power Supply)

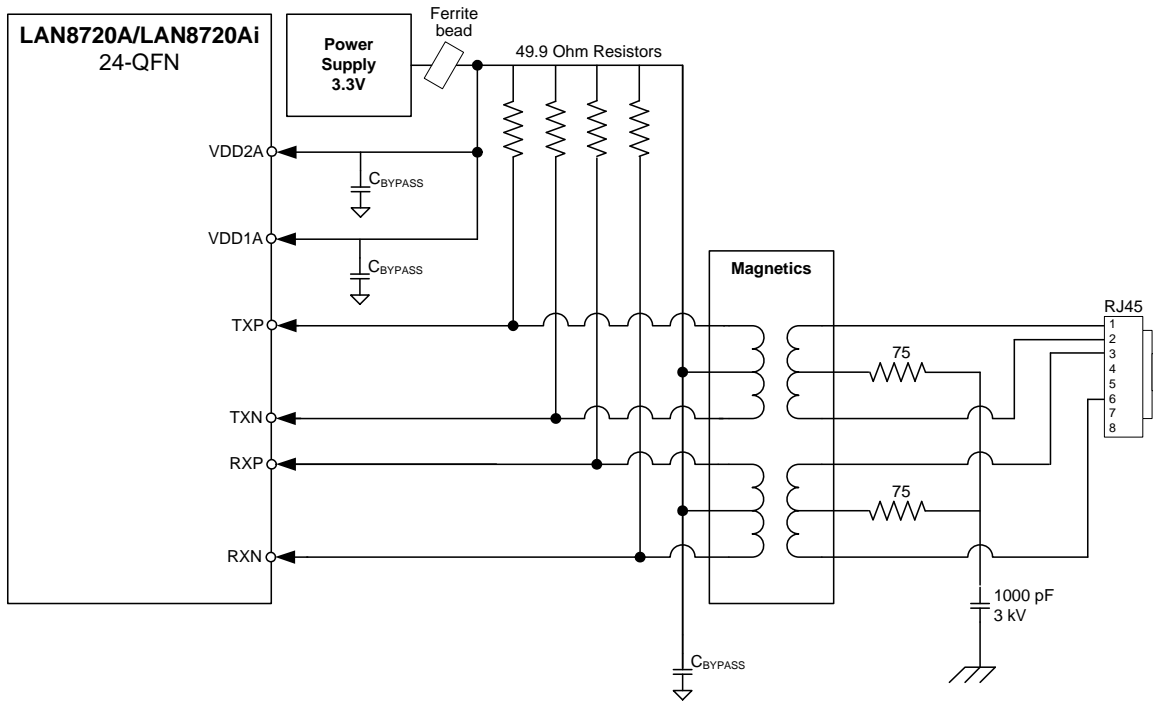

Figure 3.18 Twisted-Pair Interface Diagram (Single Power Supply)

Datasheet

3.9.5 Twisted-Pair Interface Diagram (Dual Power Supplies)

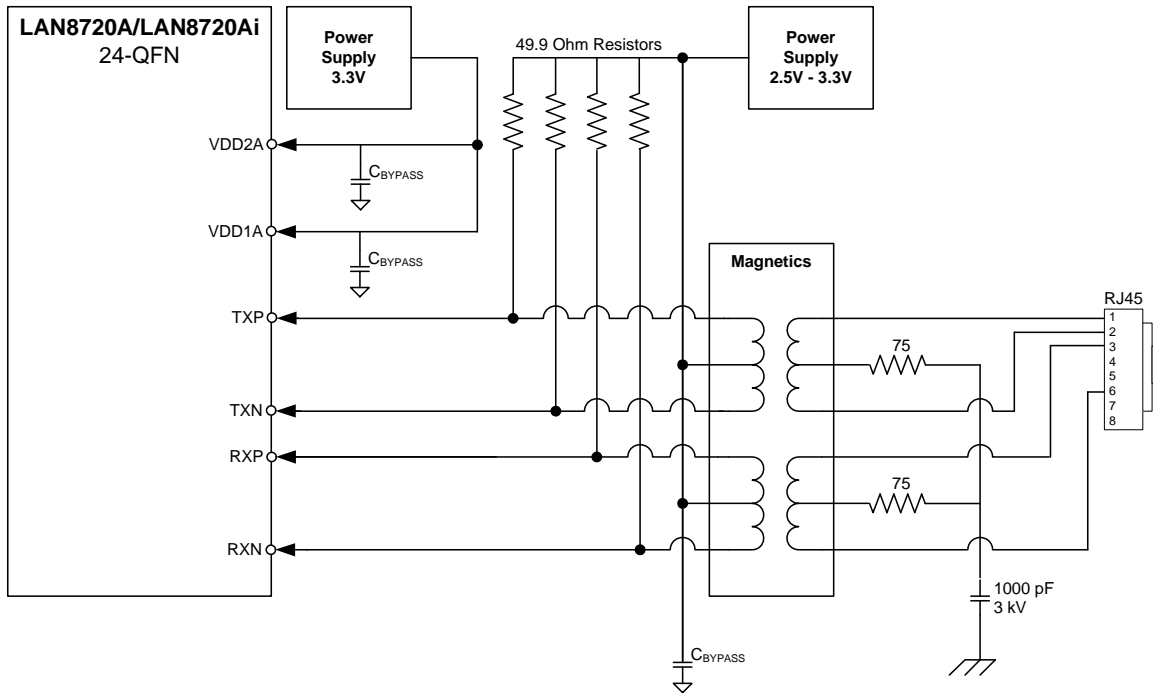

Figure 3.19 Twisted-Pair Interface Diagram (Dual Power Supplies)

Chapter 4 Register Descriptions

This chapter describes the various control and status registers (CSR's). All registers follow the IEEE 802.3 (clause 22.2.4) management register set. All functionality and bit definitions comply with these standards. The IEEE 802.3 specified register index (in decimal) is included with each register definition, allowing for addressing of these registers via the Serial Management Interface (SMI) protocol.

4.1 Register Nomenclature

Table 4.1 describes the register bit attribute notation used throughout this document.

Table 4.1 Register Bit Types

REGISTER BIT TYPE NOTATION	REGISTER BIT DESCRIPTION
R	Read: A register or bit with this attribute can be read.
W	Read: A register or bit with this attribute can be written.
RO	Read only: Read only. Writes have no effect.
WO	Write only: If a register or bit is write-only, reads will return unspecified data.
WC	Write One to Clear: writing a one clears the value. Writing a zero has no effect
WAC	Write Anything to Clear: writing anything clears the value.
RC	Read to Clear: Contents is cleared after the read. Writes have no effect.
LL	Latch Low: Clear on read of register.
LH	Latch High: Clear on read of register.
SC	Self-Clearing: Contents are self-cleared after the being set. Writes of zero have no effect. Contents can be read.
SS	Self-Setting: Contents are self-setting after being cleared. Writes of one have no effect. Contents can be read.
RO/LH	Read Only, Latch High: Bits with this attribute will stay high until the bit is read. After it is read, the bit will either remain high if the high condition remains, or will go low if the high condition has been removed. If the bit has not been read, the bit will remain high regardless of a change to the high condition. This mode is used in some Ethernet PHY registers.
NASR	Not Affected by Software Reset. The state of NASR bits do not change on assertion of a software reset.
RESERVED	Reserved Field: Reserved fields must be written with zeros to ensure future compatibility. The value of reserved bits is not guaranteed on a read.

Many of these register bit notations can be combined. Some examples of this are shown below:

- **R/W:** Can be written. Will return current setting on a read.
- **R/WAC:** Will return current setting on a read. Writing anything clears the bit.

Datasheet

4.2 Control and Status Registers

Table 4.2 provides a list of supported registers. Register details, including bit definitions, are provided in the preceding subsections.

Table 4.2 SMI Register Map

REGISTER INDEX (DECIMAL)	REGISTER NAME	GROUP
0	Basic Control Register	Basic
1	Basic Status Register	Basic
2	PHY Identifier 1	Extended
3	PHY Identifier 2	Extended
4	Auto-Negotiation Advertisement Register	Extended
5	Auto-Negotiation Link Partner Ability Register	Extended
6	Auto-Negotiation Expansion Register	Extended
17	Mode Control/Status Register	Vendor-specific
18	Special Modes	Vendor-specific
26	Symbol Error Counter Register	Vendor-specific
27	Control / Status Indication Register	Vendor-specific
29	Interrupt Source Register	Vendor-specific
30	Interrupt Mask Register	Vendor-specific
31	PHY Special Control/Status Register	Vendor-specific

4.2.1 Basic Control Register

Index (In Decimal): 0

Size: 16 bits

BITS	DESCRIPTION	TYPE	DEFAULT
15	Soft Reset 1 = software reset. Bit is self-clearing. When setting this bit do not set other bits in this register. The configuration (as described in Section 3.7.2, "MODE[2:0]: Mode Configuration," on page 31) is set from the register bit values, and not from the mode pins.	R/W SC	0b
14	Loopback 0 = normal operation 1 = loopback mode	R/W	0b
13	Speed Select 0 = 10Mbps 1 = 100Mbps Note: Ignored if Auto-negotiation is enabled (0.12 = 1).	R/W	Note 4.1
12	Auto-Negotiation Enable 0 = disable auto-negotiate process 1 = enable auto-negotiate process (overrides 0.13 and 0.8)	R/W	Note 4.1
11	Power Down 0 = normal operation 1 = General power down mode Note: The Auto-Negotiation Enable must be cleared before setting the Power Down.	R/W	0b
10	Isolate 0 = normal operation 1 = electrical isolation of PHY from the RMII	R/W	0b
9	Restart Auto-Negotiate 0 = normal operation 1 = restart auto-negotiate process Note: Bit is self-clearing.	R/W SC	0b
8	Duplex Mode 0 = half duplex 1 = full duplex Note: Ignored if Auto-Negotiation is enabled (0.12 = 1).	R/W	Note 4.1
7:0	RESERVED	RO	-

Note 4.1 The default value of this bit is determined by the MODE[2:0] configuration straps. Refer to [Section 3.7.2, "MODE\[2:0\]: Mode Configuration," on page 31](#) for additional information.

Datasheet

4.2.2 Basic Status Register

Index (In Decimal): 1

Size: 16 bits

BITS	DESCRIPTION	TYPE	DEFAULT
15	100BASE-T4 0 = no T4 ability 1 = T4 able	RO	0b
14	100BASE-TX Full Duplex 0 = no TX full duplex ability 1 = TX with full duplex	RO	1b
13	100BASE-TX Half Duplex 0 = no TX half duplex ability 1 = TX with half duplex	RO	1b
12	10BASE-T Full Duplex 0 = no 10Mbps with full duplex ability 1 = 10Mbps with full duplex	RO	1b
11	10BASE-T Half Duplex 0 = no 10Mbps with half duplex ability 1 = 10Mbps with half duplex	RO	1b
10	100BASE-T2 Full Duplex 0 = PHY not able to perform full duplex 100BASE-T2 1 = PHY able to perform full duplex 100BASE-T2	RO	0b
9	100BASE-T2 Half Duplex 0 = PHY not able to perform half duplex 100BASE-T2 1 = PHY able to perform half duplex 100BASE-T2	RO	0b
8	Extended Status 0 = no extended status information in register 15 1 = extended status information in register 15	RO	0b
7:6	RESERVED	RO	-
5	Auto-Negotiate Complete 0 = auto-negotiate process not completed 1 = auto-negotiate process completed	RO	0b
4	Remote Fault 1 = remote fault condition detected 0 = no remote fault	RO/LH	0b
3	Auto-Negotiate Ability 0 = unable to perform auto-negotiation function 1 = able to perform auto-negotiation function	RO	1b
2	Link Status 0 = link is down 1 = link is up	RO/LL	0b
1	Jabber Detect 0 = no jabber condition detected 1 = jabber condition detected	RO/LH	0b
0	Extended Capabilities 0 = does not support extended capabilities registers 1 = supports extended capabilities registers	RO	1b

4.2.3 PHY Identifier 1 Register

Index (In Decimal): 2

Size: 16 bits

BITS	DESCRIPTION	TYPE	DEFAULT
15:0	PHY ID Number Assigned to the 3rd through 18th bits of the Organizationally Unique Identifier (OUI), respectively.	R/W	0007h

Datasheet**4.2.4 PHY Identifier 2 Register**

Index (In Decimal): 3

Size: 16 bits

BITS	DESCRIPTION	TYPE	DEFAULT
15:10	PHY ID Number Assigned to the 19th through 24th bits of the OUI.	R/W	110000b
9:4	Model Number Six-bit manufacturer's model number.	R/W	001111b
3:0	Revision Number Four-bit manufacturer's revision number.	R/W	Note 4.2

Note 4.2 The default value of this field will vary dependant on the silicon revision number.

4.2.5 Auto Negotiation Advertisement Register

Index (In Decimal): 4

Size: 16 bits

BITS	DESCRIPTION	TYPE	DEFAULT
15:14	RESERVED	RO	-
13	Remote Fault 0 = no remote fault 1 = remote fault detected	R/W	0b
12	RESERVED	RO	-
11:10	Pause Operation 00 = No PAUSE 01 = Symmetric PAUSE 10 = Asymmetric PAUSE toward link partner 11 = Advertise support for both Symmetric PAUSE and Asymmetric PAUSE toward local device Note: When both Symmetric PAUSE and Asymmetric PAUSE are set, the device will only be configured to, at most, one of the two settings upon auto-negotiation completion.	R/W	00b
9	RESERVED	RO	-
8	100BASE-TX Full Duplex 0 = no TX full duplex ability 1 = TX with full duplex	R/W	Note 4.3
7	100BASE-TX 0 = no TX ability 1 = TX able	R/W	1b
6	10BASE-T Full Duplex 0 = no 10Mbps with full duplex ability 1 = 10Mbps with full duplex	R/W	Note 4.3
5	10BASE-T 0 = no 10Mbps ability 1 = 10Mbps able	R/W	Note 4.3
4:0	Selector Field 00001 = IEEE 802.3	R/W	00001b

Note 4.3 The default value of this bit is determined by the MODE[2:0] configuration straps. Refer to [Section 3.7.2, "MODE\[2:0\]: Mode Configuration," on page 31](#) for additional information.

Datasheet

4.2.6 Auto Negotiation Link Partner Ability Register

Index (In Decimal): 5

Size: 16 bits

BITS	DESCRIPTION	TYPE	DEFAULT
15	Next Page 0 = no next page ability 1 = next page capable Note: This device does not support next page ability.	RO	0b
14	Acknowledge 0 = link code word not yet received 1 = link code word received from partner	RO	0b
13	Remote Fault 0 = no remote fault 1 = remote fault detected	RO	0b
12:11	RESERVED	RO	-
10	Pause Operation 0 = No PAUSE supported by partner station 1 = PAUSE supported by partner station	RO	0b
9	100BASE-T4 0 = no T4 ability 1 = T4 able Note: This device does not support T4 ability.	RO	0b
8	100BASE-TX Full Duplex 0 = no TX full duplex ability 1 = TX with full duplex	RO	0b
7	100BASE-TX 0 = no TX ability 1 = TX able	RO	0b
6	10BASE-T Full Duplex 0 = no 10Mbps with full duplex ability 1 = 10Mbps with full duplex	RO	0b
5	10BASE-T 0 = no 10Mbps ability 1 = 10Mbps able	RO	0b
4:0	Selector Field 00001 = IEEE 802.3	RO	00001b

4.2.7 Auto Negotiation Expansion Register

Index (In Decimal): 6

Size: 16 bits

BITS	DESCRIPTION	TYPE	DEFAULT
15:5	RESERVED	RO	-
4	Parallel Detection Fault 0 = no fault detected by parallel detection logic 1 = fault detected by parallel detection logic	RO/LH	0b
3	Link Partner Next Page Able 0 = link partner does not have next page ability 1 = link partner has next page ability	RO	0b
2	Next Page Able 0 = local device does not have next page ability 1 = local device has next page ability	RO	0b
1	Page Received 0 = new page not yet received 1 = new page received	RO/LH	0b
0	Link Partner Auto-Negotiation Able 0 = link partner does not have auto-negotiation ability 1 = link partner has auto-negotiation ability	RO	0b

Datasheet

4.2.8 Mode Control/Status Register

Index (In Decimal): 17

Size: 16 bits

BITS	DESCRIPTION	TYPE	DEFAULT
15:14	RESERVED	RO	-
13	EDPWRDOWN Enable the Energy Detect Power-Down mode: 0 = Energy Detect Power-Down is disabled 1 = Energy Detect Power-Down is enabled	R/W	0b
12:10	RESERVED	RO	-
9	FARLOOPBACK Enables far loopback mode (i.e., all the received packets are sent back simultaneously (in 100BASE-TX only)). This mode works even if the Isolate bit (0.10) is set. 0 = Far loopback mode is disabled 1 = Far loopback mode is enabled Refer to Section 3.8.8.2, "Far Loopback," on page 40 for additional information.	R/W	0b
8:7	RESERVED	RO	-
6	ALTINT Alternate Interrupt Mode: 0 = Primary interrupt system enabled (Default) 1 = Alternate interrupt system enabled Refer to Section 3.6, "Interrupt Management," on page 29 for additional information.	R/W	0b
5:2	RESERVED	RO	-
1	ENERGYON Indicates whether energy is detected. This bit transitions to "0" if no valid energy is detected within 256ms. It is reset to "1" by a hardware reset and is unaffected by a software reset. Refer to Section 3.8.3.2, "Energy Detect Power-Down," on page 38 for additional information.	RO	1b
0	RESERVED	R/W	0b

4.2.9 Special Modes Register

Index (In Decimal): 18

Size: 16 bits

BITS	DESCRIPTION	TYPE	DEFAULT
15	RESERVED	RO	-
14	RESERVED Write as 1, ignore on read.	R/W NASR	1b
13:8	RESERVED	RO	-
7:5	MODE Transceiver mode of operation. Refer to Section 3.7.2, "MODE[2:0]: Mode Configuration," on page 31 for additional details.	R/W NASR	Note 4.4
4:0	PHYAD PHY Address. The PHY Address is used for the SMI address and for initialization of the Cipher (Scrambler) key. Refer to Section 3.7.1, "PHYAD[0]: PHY Address Configuration," on page 31 for additional details.	R/W NASR	Note 4.5

Note 4.4 The default value of this field is determined by the MODE[2:0] configuration straps. Refer to [Section 3.7.2, "MODE\[2:0\]: Mode Configuration," on page 31](#) for additional information.

Note 4.5 The default value of this field is determined by the PHYAD[0] configuration strap. Refer to [Section 3.7.1, "PHYAD\[0\]: PHY Address Configuration," on page 31](#) for additional information.

Datasheet

4.2.10 Symbol Error Counter Register

Index (In Decimal): 26

Size: 16 bits

BITS	DESCRIPTION	TYPE	DEFAULT
15:0	<p>SYM_ERR_CNT The symbol error counter increments whenever an invalid code symbol is received (including IDLE symbols) in 100BASE-TX mode. The counter is incremented only once per packet, even when the received packet contains more than one symbol error. This counter increments up to 65,536 (2^{16}) and rolls over to 0 after reaching the maximum value.</p> <p>Note: This register is cleared on reset, but is not cleared by reading the register. This register does not increment in 10BASE-T mode.</p>	RO	0000h

4.2.11 Special Control/Status Indications Register

Index (In Decimal): 27

Size: 16 bits

BITS	DESCRIPTION	TYPE	DEFAULT
15	AMDIXCTRL HP Auto-MDIX control: 0 = Enable Auto-MDIX 1 = Disable Auto-MDIX (use 27.13 to control channel)	R/W	0b
14	RESERVED	RO	-
13	CH_SELECT Manual channel select: 0 = MDI (TX transmits, RX receives) 1 = MDIX (TX receives, RX transmits)	R/W	0b
12	RESERVED	RO	-
11	SQEOFF Disable the SQE test (Heartbeat): 0 = SQE test is enabled 1 = SQE test is disabled	R/W NASR	0b
10:5	RESERVED	RO	-
4	XPOL Polarity state of the 10BASE-T: 0 = Normal polarity 1 = Reversed polarity	RO	0b
3:0	RESERVED	RO	-

Datasheet

4.2.12 Interrupt Source Flag Register

Index (In Decimal): 29

Size: 16 bits

BITS	DESCRIPTION	TYPE	DEFAULT
15:8	RESERVED	RO	-
7	INT7 0 = not source of interrupt 1 = ENERGYON generated	RO/LH	0b
6	INT6 0 = not source of interrupt 1 = Auto-Negotiation complete	RO/LH	0b
5	INT5 0 = not source of interrupt 1 = Remote Fault Detected	RO/LH	0b
4	INT4 0 = not source of interrupt 1 = Link Down (link status negated)	RO/LH	0b
3	INT3 0 = not source of interrupt 1 = Auto-Negotiation LP Acknowledge	RO/LH	0b
2	INT2 0 = not source of interrupt 1 = Parallel Detection Fault	RO/LH	0b
1	INT1 0 = not source of interrupt 1 = Auto-Negotiation Page Received	RO/LH	0b
0	RESERVED	RO	0b

4.2.13 Interrupt Mask Register

Index (In Decimal): 30

Size: 16 bits

BITS	DESCRIPTION	TYPE	DEFAULT
15:8	RESERVED	RO	-
7:1	<p>Mask Bits 0 = interrupt source is masked 1 = interrupt source is enabled</p> <p>Note: Refer to Section 4.2.12, "Interrupt Source Flag Register," on page 60 for details on the corresponding interrupt definitions.</p>	R/W	0000000b
0	RESERVED	RO	-

Datasheet

4.2.14 PHY Special Control/Status Register

Index (In Decimal): 31

Size: 16 bits

BITS	DESCRIPTION	TYPE	DEFAULT
15:13	RESERVED	RO	-
12	Autodone Auto-negotiation done indication: 0 = Auto-negotiation is not done or disabled (or not active) 1 = Auto-negotiation is done	RO	0b
11:5	RESERVED - Write as 0000010b, ignore on read.	R/W	0000010b
4:2	Speed Indication HCDSPEED value: 001 = 10BASE-T half-duplex 101 = 10BASE-T full-duplex 010 = 100BASE-TX half-duplex 110 = 100BASE-TX full-duplex	RO	XXX
1:0	RESERVED	RO	-

Chapter 5 Operational Characteristics

5.1 Absolute Maximum Ratings*

Supply Voltage (VDDIO, VDD1A, VDD2A) (Note 5.1)	-0.5V to +3.6V
Digital Core Supply Voltage (VDDCR) (Note 5.1)	-0.5V to +1.5V
Ethernet Magnetics Supply Voltage	-0.5V to +3.6V
Positive voltage on signal pins, with respect to ground (Note 5.2)	+6V
Negative voltage on signal pins, with respect to ground (Note 5.3)	-0.5V
Positive voltage on XTAL1/CLKIN, with respect to ground	+4.6V
Positive voltage on XTAL2, with respect to ground	+2.5V
Ambient Operating Temperature in Still Air (T_A)	Note 5.40
Storage Temperature	-55°C to +150°C
Junction to Ambient (θ_{JA})	59.8°C/W
Junction to Case (θ_{JC})	12.6°C/W
Lead Temperature Range	Refer to JEDEC Spec. J-STD-020
HBM ESD Performance per JEDEC JESD22-A114	Class 3A
IEC61000-4-2 Contact Discharge ESD Performance (Note 5.5)	+/-8kV
IEC61000-4-2 Air-Gap Discharge ESD Performance (Note 5.5)	+/-15kV
Latch-up Performance per EIA/JESD 78	+/-150mA

Note 5.1 When powering this device from laboratory or system power supplies, it is important that the absolute maximum ratings not be exceeded or device failure can result. Some power supplies exhibit voltage spikes on their outputs when AC power is switched on or off. In addition, voltage transients on the AC power line may appear on the DC output. If this possibility exists, it is suggested that a clamp circuit be used.

Note 5.2 This rating does not apply to the following pins: XTAL1/CLKIN, XTAL2, RBIAS.

Note 5.3 This rating does not apply to the following pins: RBIAS.

Note 5.4 0°C to +85°C for extended commercial version, -40°C to +85°C for industrial version.

Note 5.5 Performed by independent 3rd party test facility.

*Stresses exceeding those listed in this section could cause permanent damage to the device. This is a stress rating only. Exposure to absolute maximum rating conditions for extended periods may affect device reliability. Functional operation of the device at any condition exceeding those indicated in Section 5.2, "Operating Conditions**", Section 5.1, "Absolute Maximum Ratings**", or any other applicable section of this specification is not implied. Note, device signals are *NOT* 5 volt tolerant unless specified otherwise.

Datasheet

5.2 Operating Conditions**

Supply Voltage (VDDIO)	+1.62V to +3.6V
Analog Port Supply Voltage (VDD1A, VDD2A)	+3.0V to +3.6V
Digital Core Supply Voltage (VDDCR)	+1.14V to +1.26V
Ethernet Magnetics Supply Voltage	+2.25V to +3.6V
Ambient Operating Temperature in Still Air (T_A)	Note 5.4

**Proper operation of the device is guaranteed only within the ranges specified in this section. After the device has completed power-up, VDDIO and the magnetics power supply must maintain their voltage level with +/-10%. Varying the voltage greater than +/-10% after the device has completed power-up can cause errors in device operation.

Note: Do not drive input signals without power supplied to the device.

5.3 Power Consumption

This section details the device power measurements taken over various operating conditions. Unless otherwise noted, all measurements were taken with power supplies at nominal values (VDDIO, VDD1A, VDD2A = 3.3V, VDDCR = 1.2V). See [Section 3.8.3, "Power-Down Modes,"](#) on page 38 for a description of the power down modes. For more information on the REF_CLK modes, see [Section 3.7.4, "nINTSEL: nINT/REFCLKO Configuration,"](#) on page 33.

5.3.1 REF_CLK In Mode

Table 5.1 Device Only Current Consumption and Power Dissipation (REF_CLK In Mode)

POWER PIN GROUP		VDDA3.3 POWER PINS(mA)	VDDCR POWER PIN(mA)	VDDIO POWER PIN(mA)	TOTAL CURRENT (mA)	TOTAL POWER (mW)
100BASE-TX /W TRAFFIC	Max	28	21	0.6	49	159
	Typical	26	19	0.5	45	148
	Min	23	18	0.3	41	96 Note 5.6
10BASE-T /W TRAFFIC	Max	9.7	13	0.6	24	77
	Typical	8.9	12	0.5	22	70
	Min	8.3	12	0.3	20	42 Note 5.6
ENERGY DETECT POWER DOWN	Max	4.2	3.0	0.2	7.4	25
	Typical	4.1	1.9	0.2	6.2	21
	Min	3.9	1.9	0	5.8	16 Note 5.6
GENERAL POWER DOWN	Max	0.4	2.8	0.2	3.4	11.2
	Typical	0.3	1.8	0.2	2.3	7.6
	Min	0.3	1.7	0	2	3.0 Note 5.6

Note: The current at VDDCR is either supplied by the internal regulator from current entering at VDD2A, or from an external 1.2V supply when the internal regulator is disabled.

Note: Current measurements do not include power applied to the magnetics or the optional external LEDs. The Ethernet component current is typically 41mA in 100BASE-TX mode and 100mA in 10BASE-T mode, independent of the 2.5V or 3.3V supply rail of the transformer.

Note 5.6 Calculated with full flexPWR features activated: VDDIO=1.8V & internal regulator disabled.

5.3.2 REF_CLK Out Mode

Table 5.2 Device Only Current Consumption and Power Dissipation (REF_CLK Out Mode)

POWER PIN GROUP		VDDA3.3 POWER PINS(MA)	VDDCR POWER PIN(MA)	VDDIO POWER PIN(MA)	TOTAL CURRENT (MA)	TOTAL POWER (MW)
100BASE-T /W TRAFFIC	Max	28	20	6.3	54	179
	Typical	26	19	5.8	50	164
	Min	22	15	2.9	39	93 Note 5.7
10BASE-T /W TRAFFIC	Max	9.9	13	6.4	30	96
	Typical	8.8	12	5.6	26	85
	Min	7.1	10	3.0	20	41 Note 5.7
ENERGY DETECT POWER DOWN	Max	4.5	2.7	0.3	7.5	25
	Typical	4.0	1.5	0.2	5.7	19
	Min	3.9	1.2	0	5.1	15 Note 5.7
GENERAL POWER DOWN	Max	0.4	2.5	0.2	3.1	10.2
	Typical	0.4	1.3	0.2	1.9	6.3
	Min	0.4	1.0	0	1.4	2.5 Note 5.7

Note: The current at VDDCR is either supplied by the internal regulator from current entering at VDD2A, or from an external 1.2V supply when the internal regulator is disabled.

Note: Current measurements do not include power applied to the magnetics or the optional external LEDs. The Ethernet component current is typically 41mA in 100BASE-TX mode and 100mA in 10BASE-T mode, independent of the 2.5V or 3.3V supply rail of the transformer.

Note 5.7 Calculated with full flexPWR features activated: VDDIO=1.8V & internal regulator disabled.

Datasheet

5.4 DC Specifications

Table 5.3 details the non-variable I/O buffer characteristics. These buffer types do not support variable voltage operation. Table 5.4 details the variable voltage I/O buffer characteristics. Typical values are provided for 1.8V, 2.5V, and 3.3V VDDIO cases.

Table 5.3 Non-Variable I/O Buffer Characteristics

PARAMETER	SYMBOL	MIN	TYP	MAX	UNITS	NOTES
IS Type Input Buffer						
Low Input Level	V_{ILI}	-0.3			V	
High Input Level	V_{IHI}			3.6	V	
Negative-Going Threshold	V_{ILT}	1.01	1.19	1.39	V	Schmitt trigger
Positive-Going Threshold	V_{IHT}	1.39	1.59	1.79	V	Schmitt trigger
Schmitt Trigger Hysteresis ($V_{IHT} - V_{ILT}$)	V_{HYS}	336	399	459	mV	
Input Leakage ($V_{IN} = V_{SS}$ or V_{DDIO})	I_{IH}	-10		10	μ A	Note 5.8
Input Capacitance	C_{IN}			2	pF	
O12 Type Buffers						
Low Output Level	V_{OL}			0.4	V	$I_{OL} = 12\text{mA}$
High Output Level	V_{OH}	$V_{DD2A} - 0.4$			V	$I_{OH} = -12\text{mA}$
ICLK Type Buffer (XTAL1 Input)						
Low Input Level	V_{ILI}	-0.3		0.35	V	Note 5.9
High Input Level	V_{IHI}	1.4		$V_{DD2A} + 0.4$	V	

Note 5.8 This specification applies to all inputs and tri-stated bi-directional pins. Internal pull-down and pull-up resistors add +/- 50 μ A per-pin (typical).

Note 5.9 XTAL1/CLKIN can optionally be driven from a 25MHz single-ended clock oscillator.

Table 5.4 Variable I/O Buffer Characteristics

PARAMETER	SYMBOL	MIN	1.8V TYP	2.5V TYP	3.3V TYP	MAX	UNITS	NOTES
VIS Type Input Buffer								
Low Input Level	V_{ILI}	-0.3					V	
High Input Level	V_{IHI}					3.6	V	
Neg-Going Threshold	V_{ILT}	0.64	0.83	1.15	1.41	1.76	V	Schmitt trigger
Pos-Going Threshold	V_{IHT}	0.81	0.99	1.29	1.65	1.90	V	Schmitt trigger
Schmitt Trigger Hysteresis ($V_{IHT} - V_{ILT}$)	V_{HYS}	102	158	136	138	288	mV	
Input Leakage ($V_{IN} = V_{SS}$ or V_{DDIO})	I_{IH}	-10				10	uA	Note 5.10
Input Capacitance	C_{IN}					2	pF	
VO8 Type Buffers								
Low Output Level	V_{OL}					0.4	V	$I_{OL} = 8\text{mA}$
High Output Level	V_{OH}	$V_{DDIO} - 0.4$					V	$I_{OH} = -8\text{mA}$
VOD8 Type Buffer								
Low Output Level	V_{OL}					0.4	V	$I_{OL} = 8\text{mA}$

Note 5.10 This specification applies to all inputs and tri-stated bi-directional pins. Internal pull-down and pull-up resistors add +/- 50uA per-pin (typical).

Table 5.5 100BASE-TX Transceiver Characteristics

PARAMETER	SYMBOL	MIN	TYP	MAX	UNITS	NOTES
Peak Differential Output Voltage High	V_{PPH}	950	-	1050	mVpk	Note 5.11
Peak Differential Output Voltage Low	V_{PPL}	-950	-	-1050	mVpk	Note 5.11
Signal Amplitude Symmetry	V_{SS}	98	-	102	%	Note 5.11
Signal Rise and Fall Time	T_{RF}	3.0	-	5.0	nS	Note 5.11
Rise and Fall Symmetry	T_{RFS}	-	-	0.5	nS	Note 5.11
Duty Cycle Distortion	D_{CD}	35	50	65	%	Note 5.12
Overshoot and Undershoot	V_{OS}	-	-	5	%	
Jitter				1.4	nS	Note 5.13

Note 5.11 Measured at line side of transformer, line replaced by 100 Ω (+/- 1%) resistor.

Note 5.12 Offset from 16nS pulse width at 50% of pulse peak.

Note 5.13 Measured differentially.

Datasheet

Table 5.6 10BASE-T Transceiver Characteristics

PARAMETER	SYMBOL	MIN	TYP	MAX	UNITS	NOTES
Transmitter Peak Differential Output Voltage	V_{OUT}	2.2	2.5	2.8	V	Note 5.14
Receiver Differential Squelch Threshold	V_{DS}	300	420	585	mV	

Note 5.14 Min/max voltages guaranteed as measured with 100 Ω resistive load.

5.5 AC Specifications

This section details the various AC timing specifications of the device.

Note: The SMI timing adheres to the IEEE 802.3 specification. Refer to the IEEE 802.3 specification for additional timing information.

Note: The RMII timing adheres to the RMII Consortium RMII Specification R1.2.

5.5.1 Equivalent Test Load

Output timing specifications assume a 25pF equivalent test load, unless otherwise noted, as illustrated in [Figure 5.1](#) below.

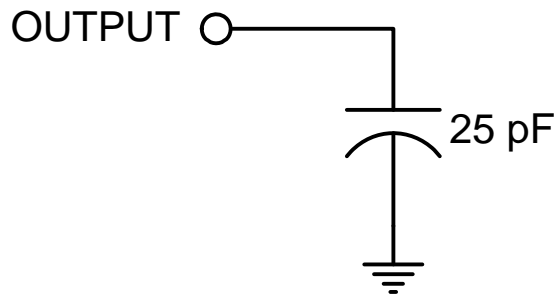

Figure 5.1 Output Equivalent Test Load

5.5.2 Power Sequence Timing

This diagram illustrates the device power sequencing requirements. The VDDIO, VDD1A, VDD2A and magnetics power supplies can turn on in any order provided they all reach operational levels within the specified time period t_{pon} . Device power supplies can turn off in any order provided they all reach 0 volts within the specified time period t_{poff} .

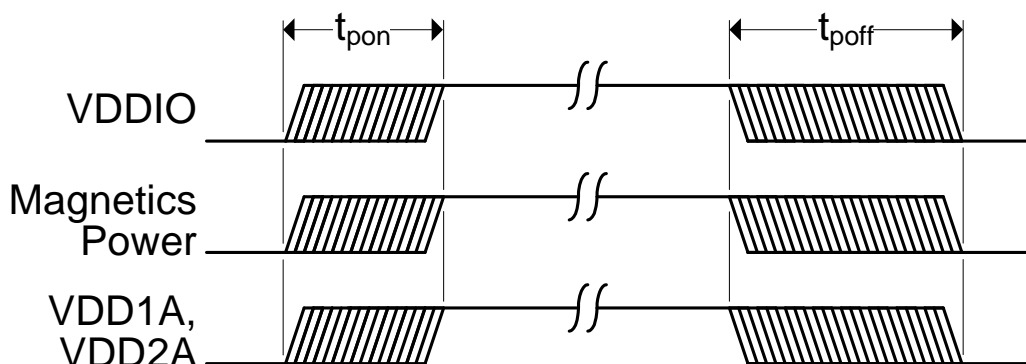

Figure 5.2 Power Sequence Timing

Table 5.7 Power Sequence Timing Values

SYMBOL	DESCRIPTION	MIN	TYP	MAX	UNITS
t_{pon}	Power supply turn on time			50	mS
t_{poff}	Power supply turn off time			500	mS

Note: When the internal regulator is disabled, a power-up sequencing relationship exists between VDDCR and the 3.3V power supply. For additional information refer to [Section 3.7.3, "REGOFF: Internal +1.2V Regulator Configuration,"](#) on page 32.

Datasheet

5.5.3 Power-On nRST & Configuration Strap Timing

This diagram illustrates the nRST reset and configuration strap timing requirements in relation to power-on. A hardware reset (nRST assertion) is required following power-up. For proper operation, nRST must be asserted for no less than t_{rstia} . The nRST pin can be asserted at any time, but must not be deasserted before t_{purstd} after all external power supplies have reached 80% of their nominal operating levels. In order for valid configuration strap values to be read at power-up, the t_{css} and t_{csh} timing constraints must be followed. Refer to [Section 3.8.5, "Resets," on page 39](#) for additional information.

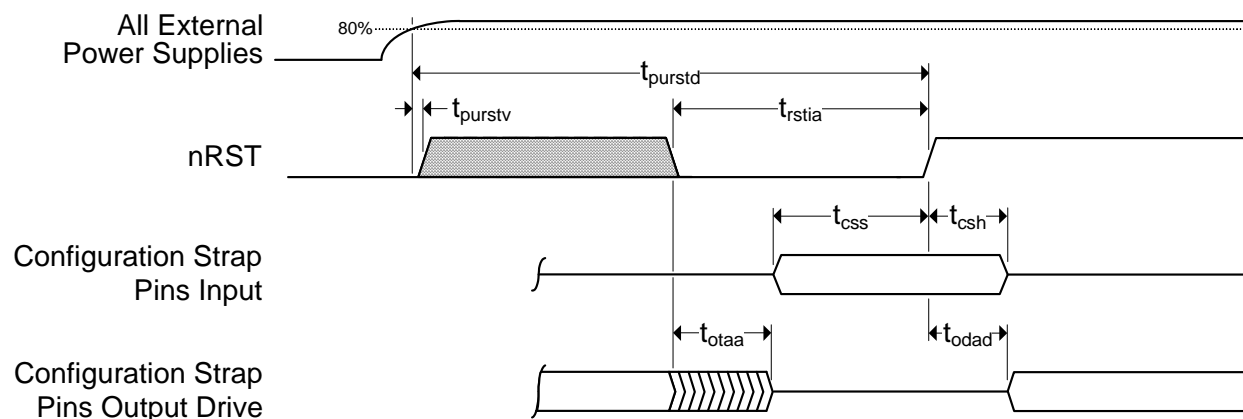

Figure 5.3 Power-On nRST & Configuration Strap Timing

Table 5.8 Power-On nRST & Configuration Strap Timing Values

SYMBOL	DESCRIPTION	MIN	TYP	MAX	UNITS
t_{purstd}	External power supplies at 80% to nRST deassertion	25			mS
t_{purstv}	External power supplies at 80% to nRST valid	0			nS
t_{rstia}	nRST input assertion time	100			μ S
t_{css}	Configuration strap pins setup to nRST deassertion	200			nS
t_{csh}	Configuration strap pins hold after nRST deassertion	1			nS
t_{otaa}	Output tri-state after nRST assertion			50	nS
t_{odad}	Output drive after nRST deassertion	2		800 (Note 5.15)	nS

Note: nRST deassertion must be monotonic.

Note: Device configuration straps are latched as a result of nRST assertion. Refer to [Section 3.7, "Configuration Straps," on page 31](#) for details. Configuration straps must only be pulled high or low and must not be driven as inputs.

Note 5.15 20 clock cycles for 25MHz, or 40 clock cycles for 50MHz.

5.5.4 RMII Interface Timing

5.5.4.1 RMII Timing (REF_CLK Out Mode)

The 50MHz REF_CLK OUT timing applies to the case when `nINTSEL` is pulled-low. In this mode, a 25MHz crystal or clock oscillator must be input on the XTAL1/CLKIN and XTAL2 pins. For more information on REF_CLK Out Mode, see [Section 3.7.4.2, "REF_CLK Out Mode," on page 34](#).

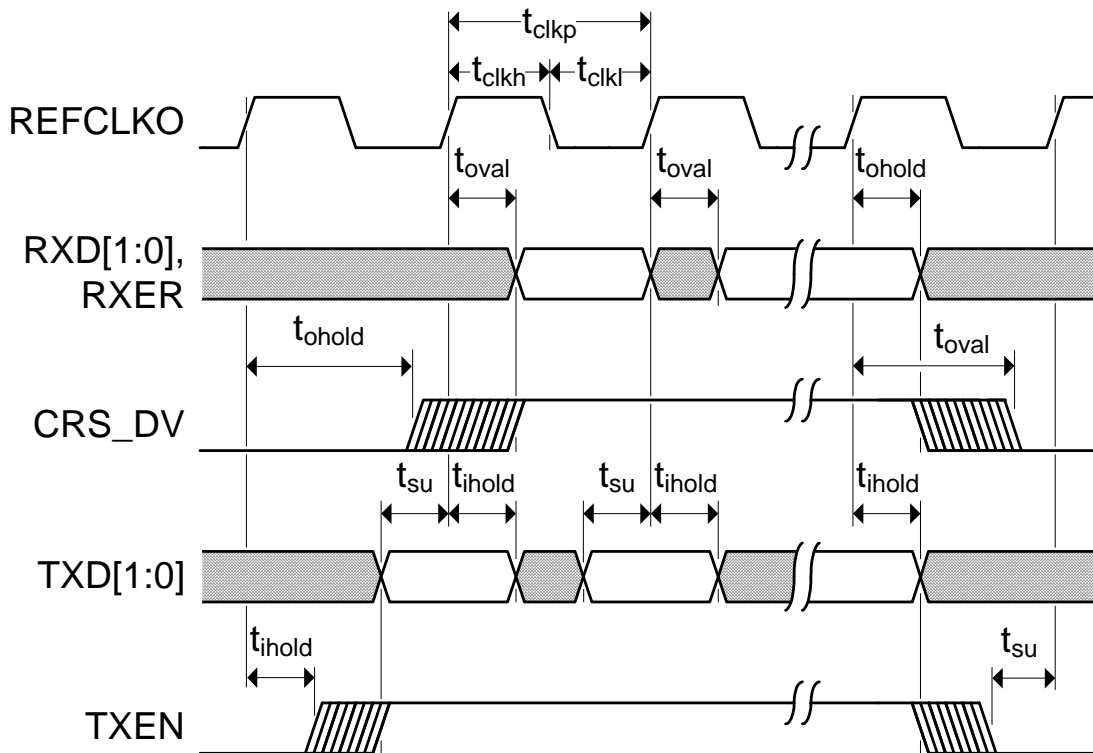

Figure 5.4 RMII Timing (REF_CLK Out Mode)

Table 5.9 RMII Timing Values (REF_CLK Out Mode)

SYMBOL	DESCRIPTION	MIN	MAX	UNITS	NOTES
t_{clkp}	REFCLKO period	20		ns	
t_{clkh}	REFCLKO high time	$t_{clkp} * 0.4$	$t_{clkp} * 0.6$	ns	
t_{clkl}	REFCLKO low time	$t_{clkp} * 0.4$	$t_{clkp} * 0.6$	ns	
t_{oval}	RXD[1:0], RXER, CRS_DV output valid from rising edge of REFCLKO		5.0	ns	Note 5.16
t_{ohold}	RXD[1:0], RXER, CRS_DV output hold from rising edge of REFCLKO	1.4		ns	Note 5.16
t_{su}	TXD[1:0], TXEN setup time to rising edge of REFCLKO	7.0		ns	Note 5.16
t_{ihold}	TXD[1:0], TXEN input hold time after rising edge of REFCLKO	2.0		ns	Note 5.16

Note 5.16 Timing was designed for system load between 10 pf and 25 pf.

Datasheet

5.5.4.2 RMII Timing (REF_CLK In Mode)

The 50MHz REF_CLK IN timing applies to the case when `nINTSEL` is floated or pulled-high. In this mode, a 50MHz clock must be input on the CLKIN pin. For more information on REF_CLK In Mode, see Section 3.7.4.1, "REF_CLK In Mode," on page 34.

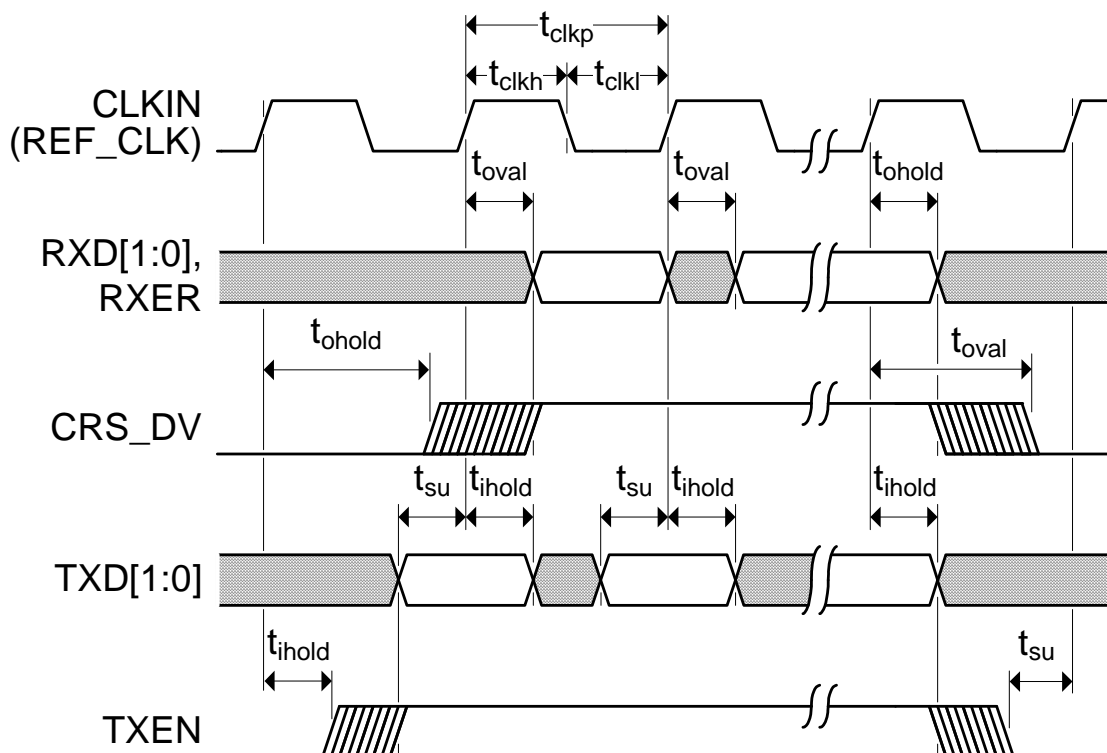

Figure 5.5 RMII Timing (REF_CLK In Mode)

Table 5.10 RMII Timing Values (REF_CLK In Mode)

SYMBOL	DESCRIPTION	MIN	MAX	UNITS	NOTES
t_{clkp}	CLKIN period	20		ns	
t_{clkh}	CLKIN high time	$t_{clkp} * 0.35$	$t_{clkp} * 0.65$	ns	
t_{clkl}	CLKIN low time	$t_{clkp} * 0.35$	$t_{clkp} * 0.65$	ns	
t_{oval}	RXD[1:0], RXER, CRS_DV output valid from rising edge of CLKIN		14.0	ns	Note 5.17
t_{ohold}	RXD[1:0], RXER, CRS_DV output hold from rising edge of CLKIN	3.0		ns	Note 5.17
t_{su}	TXD[1:0], TXEN setup time to rising edge of CLKIN	4.0		ns	Note 5.17
t_{ihold}	TXD[1:0], TXEN input hold time after rising edge of CLKIN	1.5		ns	Note 5.17

Note 5.17 Timing was designed for system load between 10 pf and 25 pf.

5.5.4.3 RMII CLKIN Requirements

Table 5.11 RMII CLKIN (REF_CLK) Timing Values

PARAMETER	MIN	TYP	MAX	UNITS	NOTES
CLKIN frequency		50		MHz	
CLKIN Frequency Drift			± 50	ppm	
CLKIN Duty Cycle	40		60	%	
CLKIN Jitter			150	psec	p-p – not RMS

5.5.5 SMI Timing

This section specifies the SMI timing of the device. Please refer to [Section 3.5, "Serial Management Interface \(SMI\)," on page 28](#) for additional details.

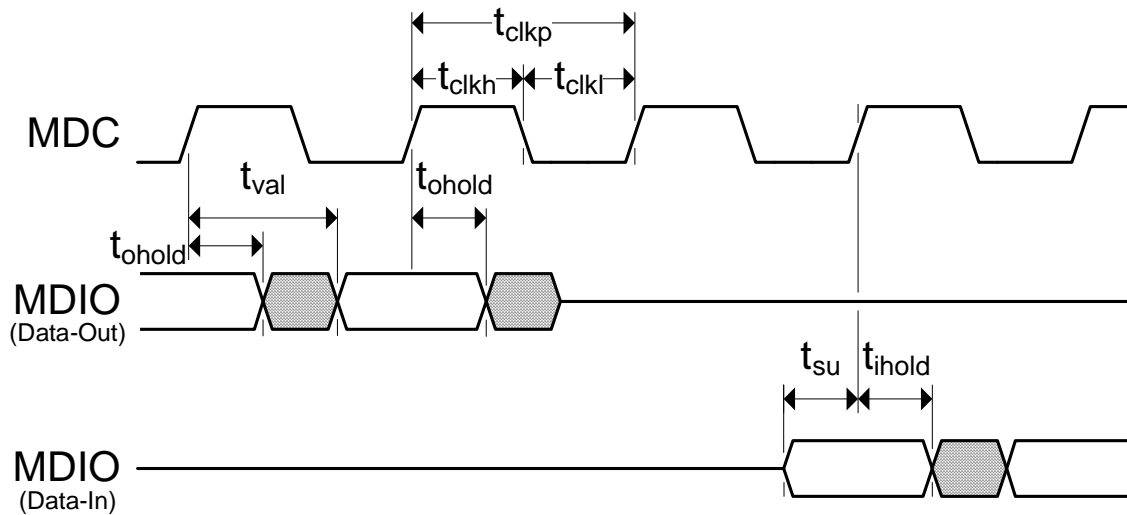

Figure 5.6 SMI Timing

Table 5.12 SMI Timing Values

SYMBOL	DESCRIPTION	MIN	MAX	UNITS	NOTES
t_{clkp}	MDC period	400		ns	
t_{clkh}	MDC high time	160 (80%)		ns	
t_{clkl}	MDC low time	160 (80%)		ns	
t_{val}	MDIO (read from PHY) output valid from rising edge of MDC		300	ns	
t_{ohold}	MDIO (read from PHY) output hold from rising edge of MDC	0		ns	
t_{su}	MDIO (write to PHY) setup time to rising edge of MDC	10		ns	
t_{ihold}	MDIO (write to PHY) input hold time after rising edge of MDC	10		ns	

Datasheet

5.6 Clock Circuit

The device can accept either a 25MHz crystal or a 25MHz single-ended clock oscillator (± 50 ppm) input. If the single-ended clock oscillator method is implemented, XTAL2 should be left unconnected and XTAL1/CLKIN should be driven with a nominal 0-3.3V clock signal. See [Table 5.13](#) for the recommended crystal specifications.

Table 5.13 Crystal Specifications

PARAMETER	SYMBOL	MIN	NOM	MAX	UNITS	NOTES
Crystal Cut	AT, typ					
Crystal Oscillation Mode	Fundamental Mode					
Crystal Calibration Mode	Parallel Resonant Mode					
Frequency	F_{fund}	-	25.000	-	MHz	
Frequency Tolerance @ 25°C	F_{tol}	-	-	± 50	PPM	Note 5.18
Frequency Stability Over Temp	F_{temp}	-	-	± 50	PPM	Note 5.18
Frequency Deviation Over Time	F_{age}	-	+/-3 to 5	-	PPM	Note 5.19
Total Allowable PPM Budget		-	-	± 50	PPM	Note 5.20
Shunt Capacitance	C_O	-	7 typ	-	pF	
Load Capacitance	C_L	-	20 typ	-	pF	
Drive Level	P_W	300	-	-	uW	
Equivalent Series Resistance	R_1	-	-	30	Ohm	
Operating Temperature Range		Note 5.21	-	+85	°C	
XTAL1/CLKIN Pin Capacitance		-	3 typ	-	pF	Note 5.22
XTAL2 Pin Capacitance		-	3 typ	-	pF	Note 5.22

Note 5.18 The maximum allowable values for Frequency Tolerance and Frequency Stability are application dependant. Since any particular application must meet the IEEE ± 50 PPM Total PPM Budget, the combination of these two values must be approximately ± 45 PPM (allowing for aging).

Note 5.19 Frequency Deviation Over Time is also referred to as Aging.

Note 5.20 The total deviation for the Transmitter Clock Frequency is specified by IEEE 802.3u as ± 100 PPM.

Note 5.21 0°C for extended commercial version, -40°C for industrial version.

Note 5.22 This number includes the pad, the bond wire and the lead frame. PCB capacitance is not included in this value. The XTAL1/CLKIN pin, XTAL2 pin and PCB capacitance values are required to accurately calculate the value of the two external load capacitors. The total load capacitance must be equivalent to what the crystal expects to see in the circuit so that the crystal oscillator will operate at 25.000 MHz.

Chapter 6 Package Outline

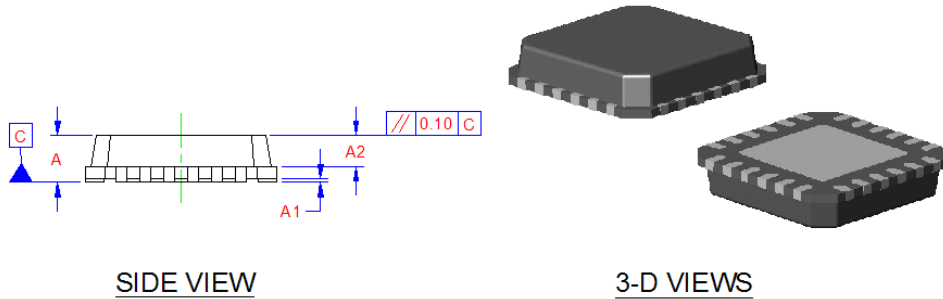
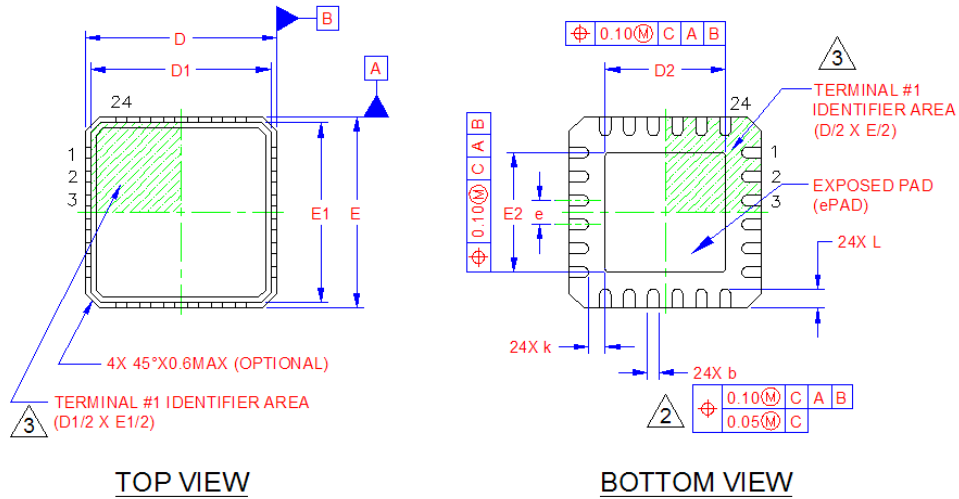

	MIN	NOMINAL	MAX	REMARKS
A	0.70	0.85	1.00	Overall Package Height
A1	0	0.02	0.05	Standoff
A2	-	-	0.90	Mold Cap Thickness
D/E	3.90	4.00	4.10	X/Y Body Size
D1/E1	3.55	3.75	3.95	X/Y Mold Cap Size
D2/E2	2.40	2.50	2.60	X/Y Exposed Pad Size
L	0.30	0.40	0.50	Terminal Length
b	0.18	0.25	0.30	Terminal Width
k	0.25	-	-	Terminal to Exposed Pad Clearance
e	0.50 BSC			Terminal Pitch

Notes:

1. All dimensions are in millimeters unless otherwise noted.
2. Dimension "b" applies to plated terminals and is measured between 0.15 and 0.30 mm from the terminal tip.
3. The pin 1 identifier may vary, but is always located within the zone indicated.

Datasheet

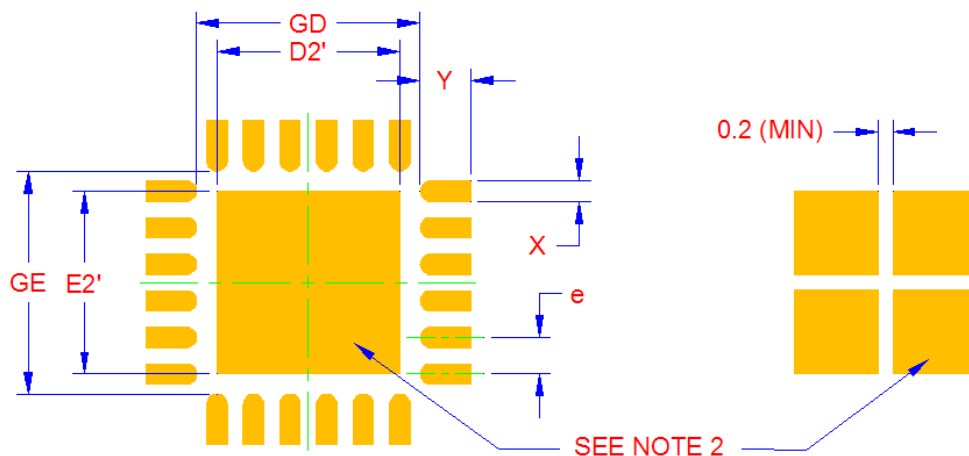

LAND PATTERN DIMENSIONS			
SYMBOL	MIN	NOM	MAX
GD/GE	3.05	-	3.10
D2'/E2'	-	2.50	2.50
Pad: X	-	0.28	0.28
Pad: Y	-	0.69	0.69
e		0.50	

NOTES:

1. THE USER MAY MODIFY THE PCB LAND PATTERN DESIGN AND DIMENSIONS BASED ON THEIR EXPERIENCE AND/OR PROCESS CAPABILITY
2. EXPOSED SOLDERABLE COPPER AREA OF THE CENTER PAD CAN BE EITHER SOLID OR SEGMENTED
3. MAXIMUM THERMAL AND ELECTRICAL PACKAGE PERFORMANCE IS ACHIEVED WHEN AN ARRAY OF SOLID VIAS IS INCORPORATED IN THE CENTER LAND PATTERN

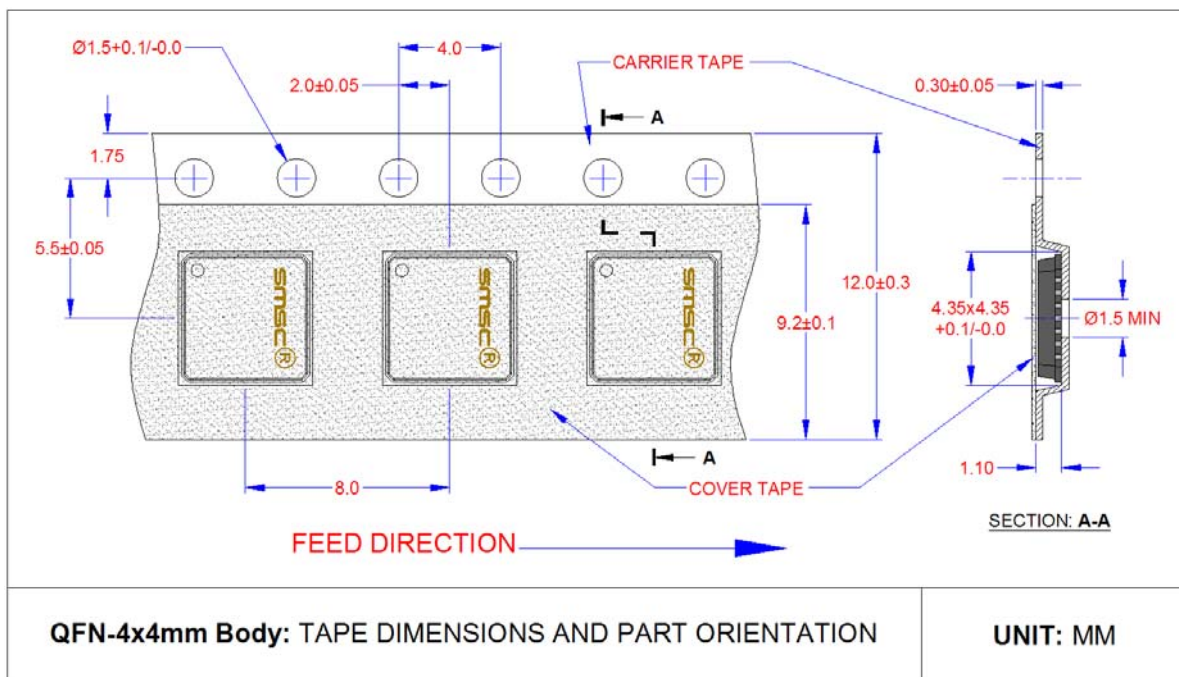

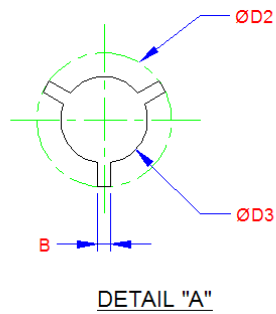
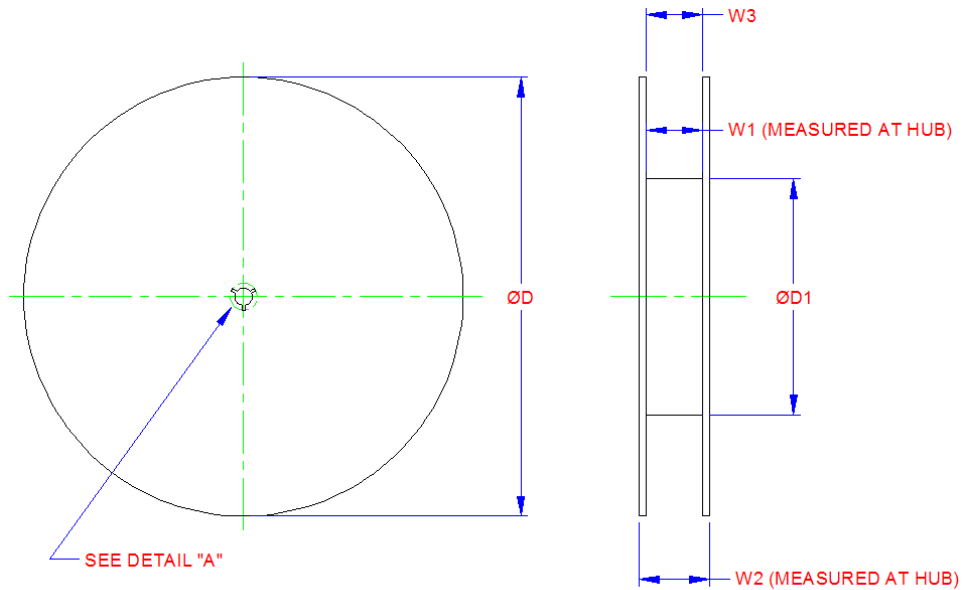

REEL DIMs for 12mm CARRIER TAPE			
PART	FEATURE	SYM	SIZE (mm)
FLANGE	DIAMETER	D	330 (+0.25/-4.00)
	SPACE between FLANGES	W1	12.4 (+2.0/-0.0)
	OVERALL WITH	W2	18.4 (MAX)
	MIN SPACE "W1" AT FLANGE EDGE	W3	12.3 (MIN)
HUB	OUTER DIAMETER	D1	177.8 REF
	KEY SLIT DIAMETER	D2	20.2 (MIN)
	ARBOR HOLE DIAMETER	D3	13.0 (+0.5/-0.2)
	KEY SLIT WIDTH	B	2.0 (±0.5)

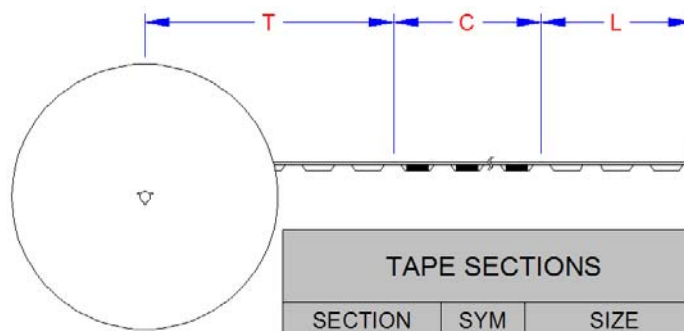

TAPE SECTIONS		
SECTION	SYM	SIZE
TRAILER	T	20 pockets (MIN)
COMPONENT	C	4000 components
LEADER	L	50 pockets (MIN)

Note: Standard reel size is 4000 pieces per reel.

Datasheet

Chapter 7 Datasheet Revision History

Table 7.1 Customer Revision History

REVISION LEVEL & DATE	SECTION/FIGURE/ENTRY	CORRECTION
Rev. 1.4 (08-23-12)	Section 4.2.2, "Basic Status Register," on page 50	Updated definitions of bits 10:8.
	Section 4.2.11, "Special Control/Status Indications Register," on page 59	Updated bit 11 definition.
Rev. 1.3 (03-12-12)	Company disclaimer on page 2	Removed company address and phone numbers.
Rev. 1.3 (04-20-11)	Table 5.9, "RMII Timing Values (REF_CLK Out Mode)," on page 71	Updated t_{oval} maximum value from 10.0ns to 5.0ns.
	Table 2.7, "Power Pins," on page 14	Updated VDDCR pin note to include requirement of 1uF and 470pF decoupling capacitors in parallel to ground on the VDDCR pin.
	Figure 3.16 Power Supply Diagram (1.2V Supplied by Internal Regulator) on page 43 and Figure 3.16 Power Supply Diagram (1.2V Supplied by Internal Regulator) on page 43	Updated diagrams to include 1uF and 470pF decoupling capacitors on the VDDCR pin.
Rev. 1.2 (11-10-10)	Section 5.5.4, "RMII Interface Timing," on page 71	Updated diagrams and tables to include RXER.
	Section 3.7.4.2, "REF_CLK Out Mode," on page 34	Added timing note in Section 3.7.4.2, "REF_CLK Out Mode"
	Section 5.5.4, "RMII Interface Timing," on page 71	Corrected signal names on RMII timing diagrams and tables. Updated Table 5.9 t_{oval} , t_{ohold} , t_{su} , and t_{ihold} with 10 ns, 1.4 ns, 7.0 ns, and 2.0 ns, respectively.
	Table 5.8, "Power-On nRST & Configuration Strap Timing Values," on page 70	Updated t_{odad} description: "Output drive after nRST deassertion"
Rev. 1.1 (04-09-10)	Section 5.1, "Absolute Maximum Ratings**"	Modified "HBM ESD Performance by adding "per JEDEC JESD22-A114" and changed "+/-5kV" to "Class 3A"
	Section 5.3, "Power Consumption," on page 64	Corrected typo in the current consumption table row title: "100BASE-TX /W TRAFFIC"
	Section 5.3, "Power Consumption," on page 64	Corrected typo in note regarding Ethernet component current: "The Ethernet component current is typically 41 mA in 100BASE-TX mode and 100mA in 10BASE-T mode, independent of the 2.5V or 3.3V supply rail of the transformer."

Table 7.1 Customer Revision History (continued)

REVISION LEVEL & DATE	SECTION/FIGURE/ENTRY	CORRECTION
	Table 5.3, "Non-Variable I/O Buffer Characteristics," on page 66	Corrected O12 V_{OH} minimum value to "VDD2A - 0.4" Corrected ICLK V_{IL} maximum value to "0.35" Corrected ICLK V_{IH} maximum value to "VDD2A + 0.4"
	Section 5.2, "Operating Conditions**," on page 64	Added note: "Do not drive input signals without power supplied to the device."
	Section 5.1, "Absolute Maximum Ratings*," on page 63	Corrected IEC61000-4-2 Contact Discharge ESD Performance to +/-8kV.
	Section 4.2.4, "PHY Identifier 2 Register," on page 52	Corrected Model Number default value to "001111b".
	Section 3.8.8.2, "Far Loopback," on page 40	Added far loopback description.
	Section 4.2.8, "Mode Control/Status Register," on page 56	Added FARLOOPBACK (bit 9) description.
Rev. 1.0 (12-09-09)	Document reworked for clarity and consistency with other SMSC documentation.	
Rev. 1.0 (04-15-09)	Initial Release	

X-ON Electronics

Largest Supplier of Electrical and Electronic Components

Click to view similar products for [Ethernet ICs category](#):

Click to view products by [Microchip manufacturer](#):

Other Similar products are found below :

[EZFM6324A S LKA5](#) [EZFM6364A S LKA7](#) [12200BS23MM](#) [EZFM5224A S LKA3](#) [VSC8522XJQ-02](#) [WGI219LM SLKJ3](#) [JL82599EN S R1ZS](#) [EZFM6348A S LKA6](#) [WGI219V SLKJ5](#) [BCM84793A1KFSBG](#) [BCM56680B1KFSBLG](#) [BCM53402A0KFSBG](#) [BCM56960B1KFSBG](#) [EZX557AT2 S LKVX](#) [BCM56842A1KFTBG](#) [BCM56450B1KFSBG](#) [EZX557AT S LKW4](#) [RTL8153-VC-CG](#) [CH395L](#) [BCM56864A1IFSBG](#) [WGI219LM SLKJ2](#) [KSZ8462FHLLI](#) [KSZ8841-16MVLI](#) [KSZ9897STXC](#) [KSZ8842-16MVLI](#) [KSZ8893MQL](#) [VSC8244XHG](#) [ADIN2111BCPZ](#) [FIDO2100BGA128IR0](#) [FIDO5210BBCZ](#) [FIDO5200CBCZ](#) [ADIN1110BCPZ](#) [ADIN1110CCPZ](#) [ADIN1100BCPZ](#) [ADIN1110CCPZ-R7](#) [ADIN1100CCPZ-R7](#) [DM9000EP](#) [DM9161AEP](#) [HG82567LM S LAVY](#) [LAN9210-ABZJ](#) [LAN9221-ABZJ](#) [LAN9221I-ABZJ](#) [LAN9211-ABZJ](#) [EZFM4105F897C S LKAM](#) [EZFM4224F1433E S LKAD](#) [EZFM4224F1433I S LKAE](#) [FBFM2112F897C S LJLS](#) [JL82576GB S LJBM](#) [JL82576NS S LJBP](#) [RC82545GM 855561](#)