



# USB 2.0 Hub and 10/100 Ethernet Controller

## PRODUCT FEATURES

Datasheet

### Highlights

- Four downstream ports, one upstream port
  - Four integrated downstream USB 2.0 PHYs
  - One integrated upstream USB 2.0 PHY
- Integrated 10/100 Ethernet MAC with full-duplex support
- Integrated 10/100 Ethernet PHY with HP Auto-MDIX
- Implements Reduced Power Operating Modes
- Minimized BOM Cost
  - Single 25 MHz crystal (Eliminates cost of separate crystals for USB and Ethernet)
  - Built-in Power-On-Reset (POR) circuit (Eliminates requirement for external passive or active reset)

### Target Applications

- Desktop PCs
- Notebook PCs
- Printers
- Game Consoles
- Embedded Systems
- Docking Stations

### Key Features

- USB Hub
  - Fully compliant with Universal Serial Bus Specification Revision 2.0
  - HS (480 Mbps), FS (12 Mbps), and LS (1.5 Mbps) compatible
  - Four downstream ports, one upstream port
  - Port mapping and disable support
  - Port Swap: Programmable USB diff-pair pin location
  - PHY Boost: Programmable USB signal drive strength
  - Select presence of a permanently hardwired USB peripheral device on a port by port basis
  - Advanced power saving features
  - Downstream PHY goes into low power mode when port power to the port is disabled
  - Full Power Management with individual or ganged power control of each downstream port.
  - Integrated USB termination Pull-up/Pull-down resistors
  - Internal short circuit protection of USB differential signal pins

- High-Performance 10/100 Ethernet Controller
  - Fully compliant with IEEE802.3/802.3u
  - Integrated Ethernet MAC and PHY
  - 10BASE-T and 100BASE-TX support
  - Full- and half-duplex support with flow control
  - Preamble generation and removal
  - Automatic 32-bit CRC generation and checking
  - Automatic payload padding and pad removal
  - Loop-back modes
  - TCP/UDP checksum offload support
  - Flexible address filtering modes
    - One 48-bit perfect address
    - 64 hash-filtered multicast addresses
    - Pass all multicast
    - Promiscuous mode
    - Inverse filtering
    - Pass all incoming with status report
  - Wakeup packet support
  - Integrated Ethernet PHY
    - Auto-negotiation, HP Auto-MDIX
    - Automatic polarity detection and correction
    - Energy Detect
- Power and I/Os
  - Three PHY LEDs
  - Eight GPIOs
  - Supports bus-powered and self-powered operation
  - Internal 1.8v core supply regulator
  - External 3.3v I/O supply
- Miscellaneous features
  - Optional EEPROM
  - Optional 24MHz reference clock output for partner hub
  - IEEE 1149.1 (JTAG) Boundary Scan
- Software
  - Windows 2000/XP/Vista Driver
  - Linux Driver
  - Win CE Driver
  - MAC OS Driver
  - EEPROM Utility
- Packaging
  - 64-pin QFN, lead-free RoHS compliant
- Environmental
  - Commercial Temperature Range (0°C to +70°C)
  - Industrial Temperature Range (-40°C to +85°C)
  - ±8kV HBM without External Protection Devices
  - ±8kV contact mode (IEC61000-4-2)
  - ±15kV air-gap discharge mode (IEC61000-4-2)

**Order Numbers:****LAN9514-JZX for 64-pin, QFN lead-free RoHS compliant package (0 to +70°C temp range)****LAN9514i-JZX for 64-pin, QFN lead-free RoHS compliant package (-40 to +85°C temp range)****This product meets the halogen maximum concentration values per IEC61249-2-21****For RoHS compliance and environmental information, please visit [www.smsc.com/rohs](http://www.smsc.com/rohs)**

Copyright © 2012 SMSC or its subsidiaries. All rights reserved.

Circuit diagrams and other information relating to SMSC products are included as a means of illustrating typical applications. Consequently, complete information sufficient for construction purposes is not necessarily given. Although the information has been checked and is believed to be accurate, no responsibility is assumed for inaccuracies. SMSC reserves the right to make changes to specifications and product descriptions at any time without notice. Contact your local SMSC sales office to obtain the latest specifications before placing your product order. The provision of this information does not convey to the purchaser of the described semiconductor devices any licenses under any patent rights or other intellectual property rights of SMSC or others. All sales are expressly conditional on your agreement to the terms and conditions of the most recently dated version of SMSC's standard Terms of Sale Agreement dated before the date of your order (the "Terms of Sale Agreement"). The product may contain design defects or errors known as anomalies which may cause the product's functions to deviate from published specifications. Anomaly sheets are available upon request. SMSC products are not designed, intended, authorized or warranted for use in any life support or other application where product failure could cause or contribute to personal injury or severe property damage. Any and all such uses without prior written approval of an Officer of SMSC and further testing and/or modification will be fully at the risk of the customer. Copies of this document or other SMSC literature, as well as the Terms of Sale Agreement, may be obtained by visiting SMSC's website at <http://www.smsc.com>. SMSC is a registered trademark of Standard Microsystems Corporation ("SMSC"). Product names and company names are the trademarks of their respective holders.

**SMSC DISCLAIMS AND EXCLUDES ANY AND ALL WARRANTIES, INCLUDING WITHOUT LIMITATION ANY AND ALL IMPLIED WARRANTIES OF MERCHANTABILITY, FITNESS FOR A PARTICULAR PURPOSE, TITLE, AND AGAINST INFRINGEMENT AND THE LIKE, AND ANY AND ALL WARRANTIES ARISING FROM ANY COURSE OF DEALING OR USAGE OF TRADE. IN NO EVENT SHALL SMSC BE LIABLE FOR ANY DIRECT, INCIDENTAL, INDIRECT, SPECIAL, PUNITIVE, OR CONSEQUENTIAL DAMAGES; OR FOR LOST DATA, PROFITS, SAVINGS OR REVENUES OF ANY KIND; REGARDLESS OF THE FORM OF ACTION, WHETHER BASED ON CONTRACT; TORT; NEGLIGENCE OF SMSC OR OTHERS; STRICT LIABILITY; BREACH OF WARRANTY; OR OTHERWISE; WHETHER OR NOT ANY REMEDY OF BUYER IS HELD TO HAVE FAILED OF ITS ESSENTIAL PURPOSE, AND WHETHER OR NOT SMSC HAS BEEN ADVISED OF THE POSSIBILITY OF SUCH DAMAGES.**

## Table of Contents

---

<b>Chapter 1 Introduction</b> .....	<b>6</b>
1.1 Block Diagram .....	6
1.1.1 Overview .....	6
1.1.2 USB Hub .....	7
1.1.3 Ethernet Controller .....	7
1.1.4 EEPROM Controller .....	7
1.1.5 Peripherals .....	7
1.1.6 Power Management .....	8
<hr/>	
<b>Chapter 2 Pin Description and Configuration</b> .....	<b>9</b>
2.1 Power Connections .....	16
2.2 Port Power Control .....	17
2.2.1 Port Power Control Using a USB Power Switch .....	17
2.2.2 Port Power Control Using a Poly Fuse .....	18
2.3 Buffer Types .....	20
<hr/>	
<b>Chapter 3 EEPROM Controller (EPC)</b> .....	<b>21</b>
3.1 EEPROM Format .....	21
3.1.1 Hub Configuration .....	24
3.2 EEPROM Defaults .....	35
3.3 EEPROM Auto-Load .....	35
3.4 An Example of EEPROM Format Interpretation .....	36
<hr/>	
<b>Chapter 4 Operational Characteristics</b> .....	<b>41</b>
4.1 Absolute Maximum Ratings* .....	41
4.2 Operating Conditions** .....	41
4.3 Power Consumption .....	42
4.3.1 SUSPEND0 .....	42
4.3.2 SUSPEND1 .....	42
4.3.3 SUSPEND2 .....	42
4.3.4 Operational Current Consumption & Power Dissipation .....	43
4.4 DC Specifications .....	44
4.5 AC Specifications .....	46
4.5.1 Equivalent Test Load .....	46
4.5.2 Reset Timing .....	46
4.5.3 EEPROM Timing .....	47
4.5.4 JTAG Timing .....	48
4.6 Clock Circuit .....	49
<hr/>	
<b>Chapter 5 Package Outline</b> .....	<b>50</b>
5.1 64-QFN Package .....	50
<hr/>	
<b>Chapter 6 Datasheet Revision History</b> .....	<b>52</b>

## List of Figures

Figure 1.1	Internal Block Diagram	6
Figure 2.1	LAN9514/LAN9514i 64-QFN Pin Assignments (TOP VIEW)	9
Figure 2.2	Power Connections	16
Figure 2.3	Port Power Control with USB Power Switch	17
Figure 2.4	Port Power Control with Poly Fuse	18
Figure 2.5	Port Power with Ganged Control with Poly Fuse	19
Figure 4.1	Output Equivalent Test Load	46
Figure 4.2	EEPROM Timing	47
Figure 4.3	JTAG Timing	48
Figure 5.1	LAN9514/LAN9514i 64-QFN Package Definition	50
Figure 5.2	LAN9514/LAN9514i Recommended PCB Land Pattern	51

## List of Tables

Table 2.1	EEPROM Pins	10
Table 2.2	JTAG Pins	10
Table 2.3	Miscellaneous Pins	10
Table 2.4	USB Pins	12
Table 2.5	Ethernet PHY Pins	14
Table 2.6	I/O Power Pins, Core Power Pins, and Ground Pad	14
Table 2.7	64-QFN Package Pin Assignments	15
Table 2.8	Buffer Types	20
Table 3.1	EEPROM Format	21
Table 3.2	Configuration Flags Description	23
Table 3.3	Hub Configuration	24
Table 3.4	Config Data Byte 1 Register (CFG1) Format	31
Table 3.5	Config Data Byte 2 Register (CFG2) Format	32
Table 3.6	Config Data Byte 3 Register (CFG3) Format	33
Table 3.7	Boost_Up Register (BOOSTUP) Format	33
Table 3.8	Boost_5 Register (BOOST5) Format	33
Table 3.9	Boost_4:2 Register (BOOST42) Format	34
Table 3.10	Status/Command Register (STCD) Format	34
Table 3.11	EEPROM Defaults	35
Table 3.12	Dump of EEPROM Memory	36
Table 3.13	EEPROM Example - 256 Byte EEPROM	37
Table 4.1	SUSPEND0 Current Consumption and Power Dissipation (VDD33IO = VDD33A = 3.3V)	42
Table 4.2	SUSPEND1 Current Consumption and Power Dissipation (VDD33IO = VDD33A = 3.3V)	42
Table 4.3	SUSPEND2 Current Consumption and Power Dissipation (VDD33IO = VDD33A = 3.3V)	42
Table 4.4	Operational Current Consumption & Power Dissipation (VDD33IO = VDD33A = 3.3V)	43
Table 4.5	I/O Buffer Characteristics	44
Table 4.6	100BASE-TX Transceiver Characteristics	45
Table 4.7	10BASE-T Transceiver Characteristics	45
Table 4.8	EEPROM Timing Values	47
Table 4.9	JTAG Timing Values	48
Table 4.10	LAN9514/LAN9514i Crystal Specifications	49
Table 5.1	LAN9514/LAN9514i 64-QFN Dimensions	50
Table 6.1	Customer Revision History	52

## Chapter 1 Introduction

### 1.1 Block Diagram

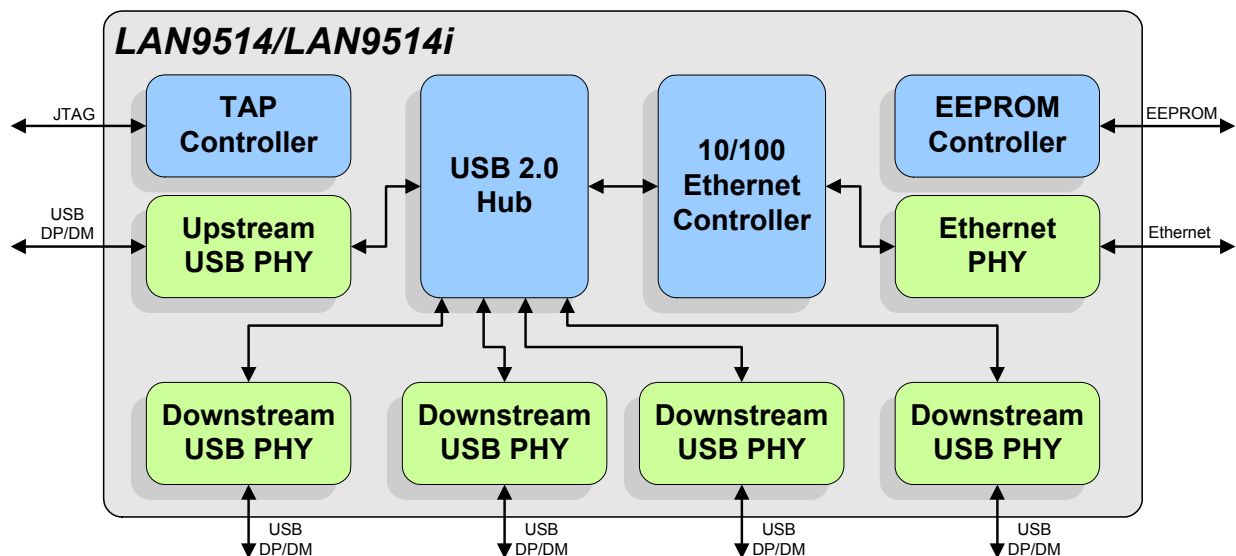

Figure 1.1 Internal Block Diagram

#### 1.1.1 Overview

The LAN9514/LAN9514i is a high performance Hi-Speed USB 2.0 hub with a 10/100 Ethernet controller. With applications ranging from embedded systems, desktop PCs, notebook PCs, printers, game consoles, and docking stations, the LAN9514/LAN9514i is targeted as a high performance, low cost USB/Ethernet and USB/USB connectivity solution.

The LAN9514/LAN9514i contains an integrated USB 2.0 hub, four integrated downstream USB 2.0 PHYs, an integrated upstream USB 2.0 PHY, a 10/100 Ethernet PHY, a 10/100 Ethernet Controller, a TAP controller, and a EEPROM controller. A block diagram of the LAN9514/LAN9514i is provided in [Figure 1.1](#).

The LAN9514/LAN9514i hub provides over 30 programmable features, including:

**PortMap** (also referred to as port remap) which provides flexible port mapping and disabling sequences. The downstream ports of the LAN9514/LAN9514i hub can be reordered or disabled in any sequence to support multiple platform designs with minimum effort. For any port that is disabled, the LAN9514/LAN9514i automatically reorders the remaining ports to match the USB host controller's port numbering scheme.

**PortSwap** which adds per-port programmability to USB differential-pair pin locations. PortSwap allows direct alignment of USB signals (D+/D-) to connectors avoiding uneven trace length or crossing of the USB differential signals on the PCB.

**PHYBoost** which enables four programmable levels of USB signal drive strength in USB port transceivers. PHYBoost attempts to restore USB signal integrity that has been compromised by system level variables such as poor PCB layout, long cables, etc.

## 1.1.2 USB Hub

The integrated USB hub is fully compliant with the USB 2.0 Specification and will attach to a USB host as a Full-Speed Hub or as a Full-/High-Speed Hub. The hub supports Low-Speed, Full-Speed, and High-Speed (if operating as a High-Speed hub) downstream devices on all of the enabled downstream ports.

A dedicated Transaction Translator (TT) is available for each downstream facing port. This architecture ensures maximum USB throughput for each connected device when operating with mixed-speed peripherals.

The hub works with an external USB power distributed switch device to control  $V_{BUS}$  switching to downstream ports, and to limit current and sense over-current conditions.

All required resistors on the USB ports are integrated into the hub. This includes all series termination resistors on D+ and D- pins and all required pull-down and pull-up resistors on D+ and D- pins. The over-current sense inputs for the downstream facing ports have internal pull-up resistors.

Four external ports are available for general USB device connectivity.

## 1.1.3 Ethernet Controller

The 10/100 Ethernet controller provides an integrated Ethernet MAC and PHY which are fully IEEE 802.3 10BASE-T and 802.3u 100BASE-TX compliant. The 10/100 Ethernet controller also supports numerous power management wakeup features, including “Magic Packet”, “Wake on LAN” and “Link Status Change”. These wakeup events can be programmed to initiate a USB remote wakeup.

The 10/100 Ethernet PHY integrates an IEEE 802.3 physical layer for twisted pair Ethernet applications. The PHY block includes support for auto-negotiation, full or half-duplex configuration, auto-polarity correction and Auto-MDIX. Minimal external components are required for the utilization of the integrated PHY.

The Ethernet controller implements four USB endpoints: Control, Interrupt, Bulk-in, and Bulk-out. The Bulk-in and Bulk-out Endpoints allow for Ethernet reception and transmission respectively. Implementation of vendor-specific commands allows for efficient statistics gathering and access to the Ethernet controller’s system control and status registers.

## 1.1.4 EEPROM Controller

The LAN9514/LAN9514i contains an EEPROM controller for connection to an external EEPROM. This allows for the automatic loading of static configuration data upon power-on reset, pin reset, or software reset. The EEPROM can be configured to load USB descriptors, USB device configuration, and the MAC address.

## 1.1.5 Peripherals

The LAN9514/LAN9514i also contains a TAP controller, and provides three PHY LED indicators, as well as eight general purpose I/O pins. All GPIOs can serve as remote wakeup events when LAN9514/LAN9514i is in a suspended state.

The integrated IEEE 1149.1 compliant TAP controller provides boundary scan via JTAG.

## 1.1.6 Power Management

The LAN9514/LAN9514i features three variations of USB suspend: SUSPEND0, SUSPEND1, and SUSPEND2. These modes allow the application to select the ideal balance of remote wakeup functionality and power consumption.

- **SUSPEND0:** Supports GPIO, “Wake On LAN”, and “Magic Packet” remote wakeup events. This suspend state reduces power by stopping the clocks of the MAC and other internal modules.
- **SUSPEND1:** Supports GPIO and “Link Status Change” for remote wakeup events. This suspend state consumes less power than SUSPEND0.
- **SUSPEND2:** Supports only GPIO assertion for a remote wakeup event. This is the default suspend mode for the LAN9514/LAN9514i.



## Chapter 2 Pin Description and Configuration

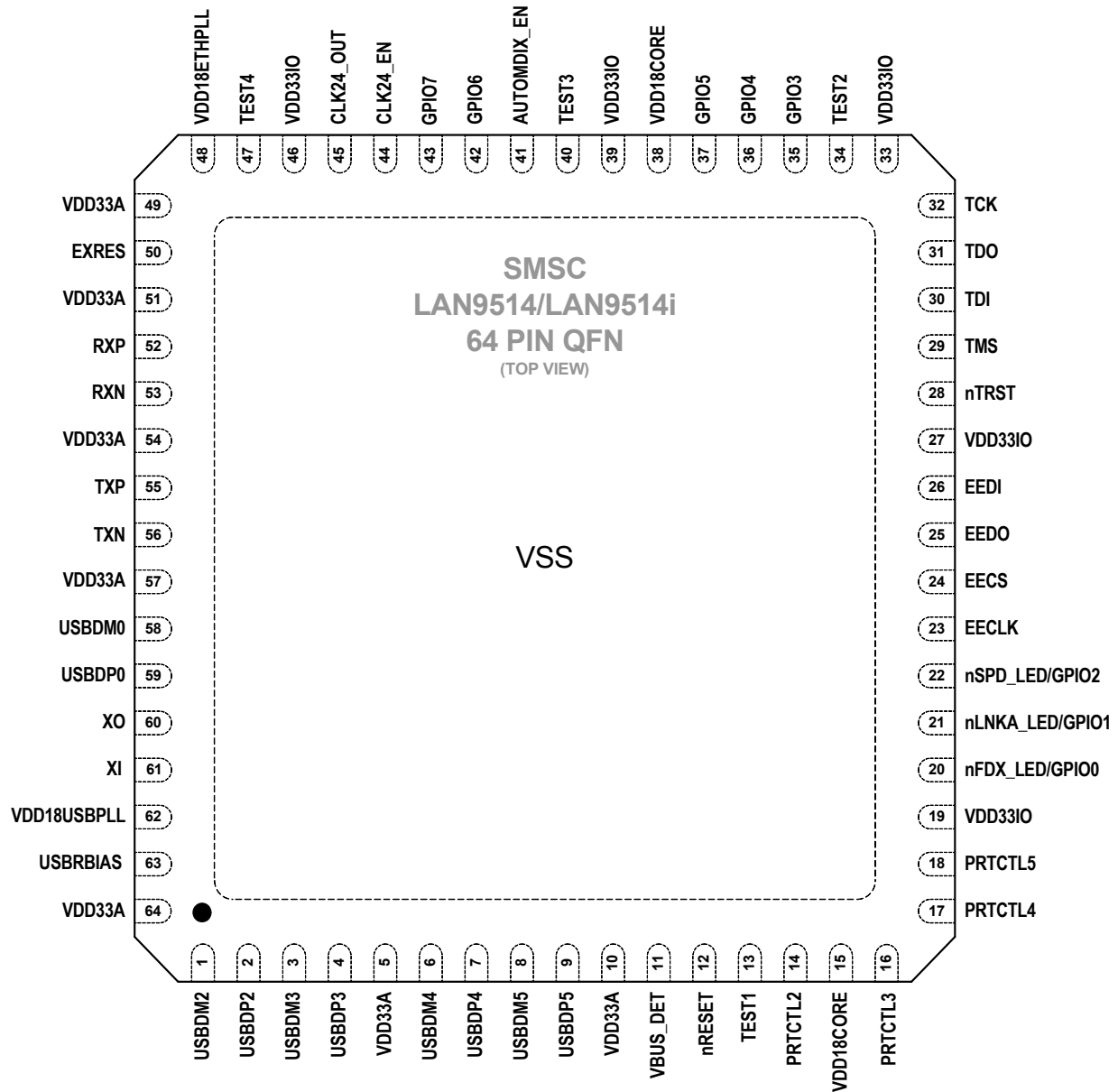

NOTE: When HP Auto-MDIX is activated, the TXN/TXP pins can function as RXN/RXP and vice-versa

NOTE: Exposed pad (VSS) on bottom of package must be connected to ground

Figure 2.1 LAN9514/LAN9514i 64-QFN Pin Assignments (TOP VIEW)

**Table 2.1 EEPROM Pins**

NUM PINS	NAME	SYMBOL	BUFFER TYPE	DESCRIPTION
1	EEPROM Data In	EEDI	IS (PD)	This pin is driven by the EEDO output of the external EEPROM.
1	EEPROM Data Out	EEDO	O8	This pin drives the EEDI input of the external EEPROM.
1	EEPROM Chip Select	EECS	O8	This pin drives the chip select output of the external EEPROM.
1	EEPROM Clock	EECLK	O8	This pin drives the EEPROM clock of the external EEPROM.

**Table 2.2 JTAG Pins**

NUM PINS	NAME	SYMBOL	BUFFER TYPE	DESCRIPTION
1	JTAG Test Port Reset	nTRST	IS	This active low pin functions as the JTAG test port reset input. <b>Note:</b> This pin should be tied high if it is not used.
1	JTAG Test Mode Select	TMS	IS	This pin functions as the JTAG test mode select.
1	JTAG Test Data Input	TDI	IS	This pin functions as the JTAG data input.
1	JTAG Test Data Out	TDO	O12	This pin functions as the JTAG data output.
1	JTAG Test Clock	TCK	IS	This pin functions as the JTAG test clock.

**Table 2.3 Miscellaneous Pins**

NUM PINS	NAME	SYMBOL	BUFFER TYPE	DESCRIPTION
1	System Reset	nRESET	IS	This active low pin allows external hardware to reset the device. <b>Note:</b> This pin should be tied high if it is not used.
1	Ethernet Full-Duplex Indicator LED	nFDX_LED	OD12 (PU)	This pin is driven low (LED on) when the Ethernet link is operating in full-duplex mode.
	General Purpose I/O 0	GPIO0	IS/O12/OD12 (PU)	This General Purpose I/O pin is fully programmable as either a push-pull output, an open-drain output, or a Schmitt-triggered input.

Table 2.3 Miscellaneous Pins (continued)

NUM PINS	NAME	SYMBOL	BUFFER TYPE	DESCRIPTION
1	Ethernet Link Activity Indicator LED	nLNKA_LED	OD12 (PU)	This pin is driven low (LED on) when a valid link is detected. This pin is pulsed high (LED off) for 80mS whenever transmit or receive activity is detected. This pin is then driven low again for a minimum of 80mS, after which time it will repeat the process if TX or RX activity is detected. Effectively, LED2 is activated solid for a link. When transmit or receive activity is sensed, LED2 will function as an activity indicator.
	General Purpose I/O 1	GPIO1	IS/O12/OD12 (PU)	This General Purpose I/O pin is fully programmable as either a push-pull output, an open-drain output, or a Schmitt-triggered input.
1	Ethernet Speed Indicator LED	nSPD_LED	OD12 (PU)	This pin is driven low (LED on) when the Ethernet operating speed is 100Mbps, or during auto-negotiation. This pin is driven high during 10Mbps operation, or during line isolation.
	General Purpose I/O 2	GPIO2	IS/O12/OD12 (PU)	This General Purpose I/O pin is fully programmable as either a push-pull output, an open-drain output, or a Schmitt-triggered input.
1	General Purpose I/O 3	GPIO3	IS/O8/OD8 (PU)	This General Purpose I/O pin is fully programmable as either a push-pull output, an open-drain output, or a Schmitt-triggered input.
1	General Purpose I/O 4	GPIO4	IS/O8/OD8 (PU)	This General Purpose I/O pin is fully programmable as either a push-pull output, an open-drain output, or a Schmitt-triggered input.
1	General Purpose I/O 5	GPIO5	IS/O8/OD8 (PU)	This General Purpose I/O pin is fully programmable as either a push-pull output, an open-drain output, or a Schmitt-triggered input.
1	General Purpose I/O 6	GPIO6	IS/O8/OD8 (PU)	This General Purpose I/O pin is fully programmable as either a push-pull output, an open-drain output, or a Schmitt-triggered input.
1	General Purpose I/O 7	GPIO7	IS/O8/OD8 (PU)	This General Purpose I/O pin is fully programmable as either a push-pull output, an open-drain output, or a Schmitt-triggered input.
1	Detect Upstream VBUS Power	VBUS_DET	IS_5V	<p>This pin detects the state of the upstream bus power. The Hub monitors VBUS_DET to determine when to assert the USBDP0 pin's internal pull-up resistor (signaling a connect event).</p> <p>For bus powered hubs, this pin must be tied to VDD33IO.</p> <p>For self powered hubs where the device is permanently attached to a host, VBUS_DET should be pulled to VDD33IO. For other self powered applications, refer to the device reference schematic for additional connection information.</p>
1	Auto-MDIX Enable	AUTOMDIX_EN	IS	<p>Determines the default Auto-MDIX setting.</p> <p>0 = Auto-MDIX is disabled. 1 = Auto-MDIX is enabled.</p>

**Table 2.3 Miscellaneous Pins (continued)**

NUM PINS	NAME	SYMBOL	BUFFER TYPE	DESCRIPTION
1	Test 1	TEST1	-	Used for factory testing, this pin must always be left unconnected.
1	Test 2	TEST2	-	Used for factory testing, this pin must always be connected to VSS for proper operation.
1	Test 3	TEST3	-	Used for factory testing, this pin must always be connected to VDD33IO for proper operation.
1	24 MHz Clock Enable	CLK24_EN	IS	This pin enables the generation of the 24 MHz clock on the CLK_24_OUT pin.
1	24 MHz Clock	CLK24_OUT	08	This pin outputs a 24 MHz clock that can be used a reference clock for a partner hub.
1	Test 4	TEST4	-	Used for factory testing, this pin must always be left unconnected.

**Table 2.4 USB Pins**

NUM PINS	NAME	SYMBOL	BUFFER TYPE	DESCRIPTION
1	Upstream USB DMINUS 0	USBDM0	AIO	Upstream USB DMINUS signal.
1	Upstream USB DPLUS 0	USBDP0	AIO	Upstream USB DPLUS signal.
1	Downstream USB DMINUS 2	USBDM2	AIO	Downstream USB peripheral 2 DMINUS signal.
1	Downstream USB DPLUS 2	USBDP2	AIO	Downstream USB peripheral 2 DPLUS signal.
1	Downstream USB DMINUS 3	USBDM3	AIO	Downstream USB peripheral 3 DMINUS signal.
1	Downstream USB DPLUS 3	USBDP3	AIO	Downstream USB peripheral 3 DPLUS signal.
1	Downstream USB DMINUS 4	USBDM4	AIO	Downstream USB peripheral 4 DMINUS signal.
1	Downstream USB DPLUS 4	USBDP4	AIO	Downstream USB peripheral 4 DPLUS signal.
1	Downstream USB DMINUS 5	USBDM5	AIO	Downstream USB peripheral 5 DMINUS signal.
1	Downstream USB DPLUS 5	USBDP5	AIO	Downstream USB peripheral 5 DPLUS signal.

Table 2.4 USB Pins (continued)

NUM PINS	NAME	SYMBOL	BUFFER TYPE	DESCRIPTION
1	USB Port Power Control 2	PRTCTL2	IS/OD12 (PU)	<p>When used as an output, this pin enables power to downstream USB peripheral 2.</p> <p>When used as an input, this pin is used to sample the output signal from an external current monitor for downstream USB peripheral 2. An overcurrent condition is indicated when the signal is low.</p> <p>Refer to <a href="#">Section 2.2</a> for additional information.</p>
1	USB Port Power Control 3	PRTCTL3	IS/OD12 (PU)	<p>When used as an output, this pin enables power to downstream USB peripheral 3.</p> <p>When used as an input, this pin is used to sample the output signal from an external current monitor for downstream USB peripheral 3. An overcurrent condition is indicated when the signal is low.</p> <p>Refer to <a href="#">Section 2.2</a> for additional information.</p>
1	USB Port Power Control 4	PRTCTL4	IS/OD12 (PU)	<p>When used as an output, this pin enables power to downstream USB peripheral 4.</p> <p>When used as an input, this pin is used to sample the output signal from an external current monitor for downstream USB peripheral 4. An overcurrent condition is indicated when the signal is low.</p> <p>Refer to <a href="#">Section 2.2</a> for additional information.</p>
1	USB Port Power Control 5	PRTCTL5	IS/OD12 (PU)	<p>When used as an output, this pin enables power to downstream USB peripheral 5.</p> <p>When used as an input, this pin is used to sample the output signal from an external current monitor for downstream USB peripheral 5. An overcurrent condition is indicated when the signal is low.</p> <p>Refer to <a href="#">Section 2.2</a> for additional information.</p>
1	External USB Bias Resistor	USBRBIAS	AI	Used for setting HS transmit current level and on-chip termination impedance. Connect to an external 12K 1.0% resistor to ground.
1	USB PLL +1.8V Power Supply	VDD18USBPLL	P	Refer to the LAN9514/LAN9514i reference schematics for additional connection information.
1	Crystal Input	XI	ICLK	<p>External 25 MHz crystal input.</p> <p><b>Note:</b> This pin can also be driven by a single-ended clock oscillator. When this method is used, XO should be left unconnected</p>
1	Crystal Output	XO	OCLK	External 25 MHz crystal output.

**Table 2.5 Ethernet PHY Pins**

NUM PINS	NAME	SYMBOL	BUFFER TYPE	DESCRIPTION
1	Ethernet TX Data Out Negative	TXN	AIO	Negative output of the Ethernet transmitter. The transmit data outputs may be swapped internally with receive data inputs when Auto-MDIX is enabled.
1	Ethernet TX Data Out Positive	TXP	AIO	Positive output of the Ethernet transmitter. The transmit data outputs may be swapped internally with receive data inputs when Auto-MDIX is enabled.
1	Ethernet RX Data In Negative	RXN	AIO	Negative input of the Ethernet receiver. The receive data inputs may be swapped internally with transmit data outputs when Auto-MDIX is enabled.
1	Ethernet RX Data In Positive	RXP	AIO	Positive input of the Ethernet receiver. The receive data inputs may be swapped internally with transmit data outputs when Auto-MDIX is enabled.
7	+3.3V Analog Power Supply	VDD33A	P	Refer to the LAN9514/LAN9514i reference schematics for connection information.
1	External PHY Bias Resistor	EXRES	AI	Used for the internal bias circuits. Connect to an external 12.4K 1.0% resistor to ground.
1	Ethernet PLL +1.8V Power Supply	VDD18ETHPLL	P	Refer to the LAN9514/LAN9514i reference schematics for additional connection information.

**Table 2.6 I/O Power Pins, Core Power Pins, and Ground Pad**

NUM PINS	NAME	SYMBOL	BUFFER TYPE	DESCRIPTION
5	+3.3V I/O Power	VDD33IO	P	+3.3V Power Supply for I/O Pins. Refer to the LAN9514/LAN9514i reference schematics for connection information.
2	Digital Core +1.8V Power Supply Output	VDD18CORE	P	+1.8 V power from the internal core voltage regulator. All VDD18CORE pins must be tied together for proper operation. Refer to the LAN9514/LAN9514i reference schematics for connection information.
1 <a href="#">Note 2.1</a>	Ground	VSS	P	Ground

**Note 2.1** Exposed pad on package bottom ([Figure 2.1](#)).

Table 2.7 64-QFN Package Pin Assignments

PIN NUM	PIN NAME	PIN NUM	PIN NAME	PIN NUM	PIN NAME	PIN NUM	PIN NAME
1	USBDM2	17	PRTCTL4	33	VDD33IO	49	VDD33A
2	USBDP2	18	PRTCTL5	34	TEST2	50	EXRES
3	USBDM3	19	VDD33IO	35	GPIO3	51	VDD33A
4	USBDP3	20	nFDX_LED/ GPIO0	36	GPIO4	52	RXP
5	VDD33A	21	nLNKA_LED/ GPIO1	37	GPIO5	53	RXN
6	USBDM4	22	nSPD_LED/ GPIO2	38	VDD18CORE	54	VDD33A
7	USBDP4	23	EECLK	39	VDD33IO	55	TXP
8	USBDM5	24	EECS	40	TEST3	56	TXN
9	USBDP5	25	EEDO	41	AUTOMDIX_EN	57	VDD33A
10	VDD33A	26	EEDI	42	GPIO6	58	USBDM0
11	VBUS_DET	27	VDD33IO	43	GPIO7	59	USBDP0
12	nRESET	28	nTRST	44	CLK24_EN	60	XO
13	TEST1	29	TMS	45	CLK24_OUT	61	XI
14	PRTCTL2	30	TDI	46	VDD33IO	62	VDD18USBPLL
15	VDD18CORE	31	TDO	47	TEST4	63	USBRBIAS
16	PRTCTL3	32	TCK	48	VDD18ETHPLL	64	VDD33A
EXPOSED PAD MUST BE CONNECTED TO VSS							

## 2.1 Power Connections

Figure 2.2 illustrates the power connections for LAN9514/LAN9514i..

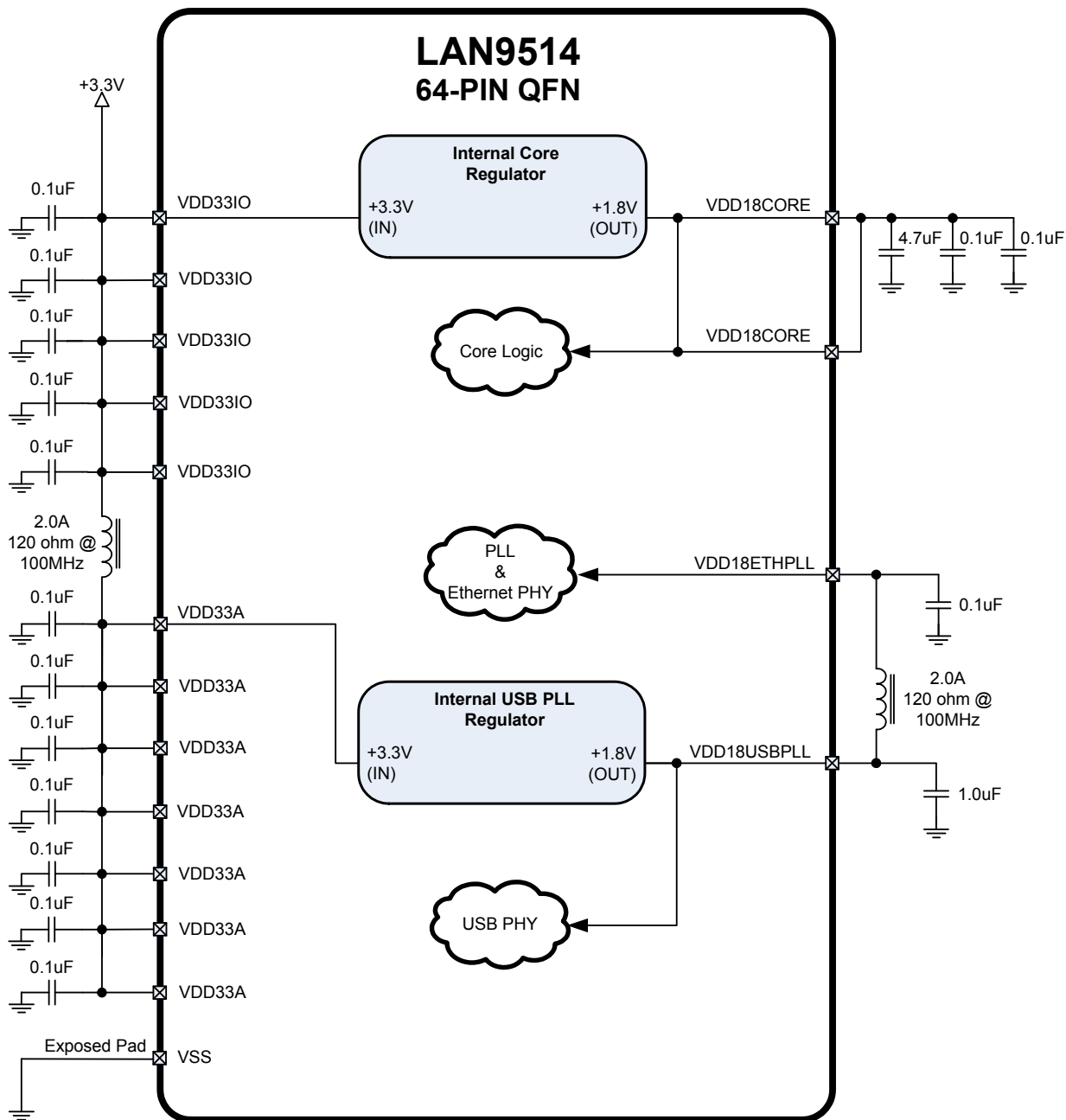

Figure 2.2 Power Connections



## 2.2 Port Power Control

This section details the usage of the port power control pins PRTCTL[5:2].

### 2.2.1 Port Power Control Using a USB Power Switch

The LAN9514/LAN9514i has a single port power control and over-current sense signal for each downstream port. When disabling port power the driver will actively drive a '0'. To avoid unnecessary power dissipation, the internal pull-up resistor will be disabled at that time. When port power is enabled, the output driver is disabled and the pull-up resistor is enabled, creating an open drain output. If there is an over-current situation, the USB Power Switch will assert the open drain OCS signal. The schmitt trigger input will recognize this situation as a low. The open drain output does not interfere. The overcurrent sense filter handles the transient conditions, such as low voltage, while the device is powering up.

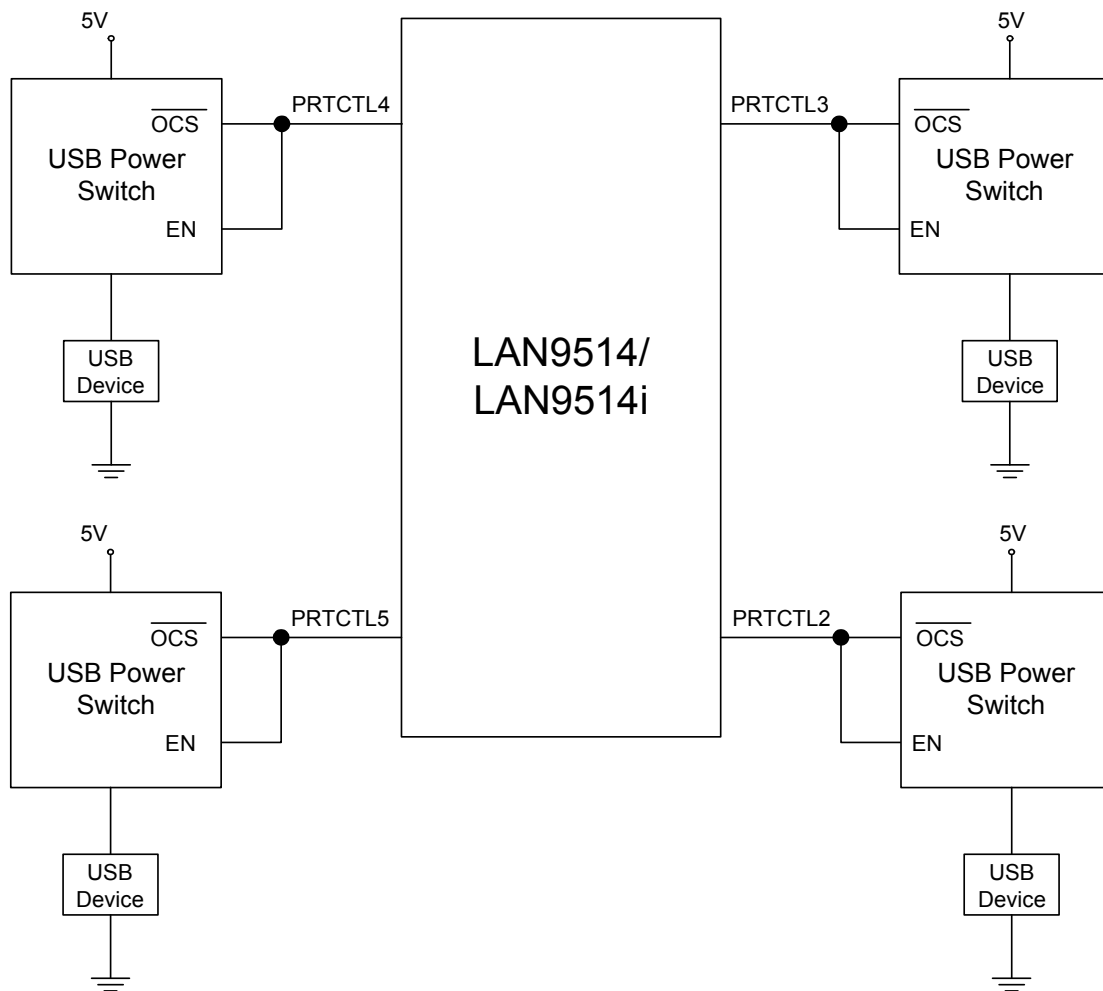
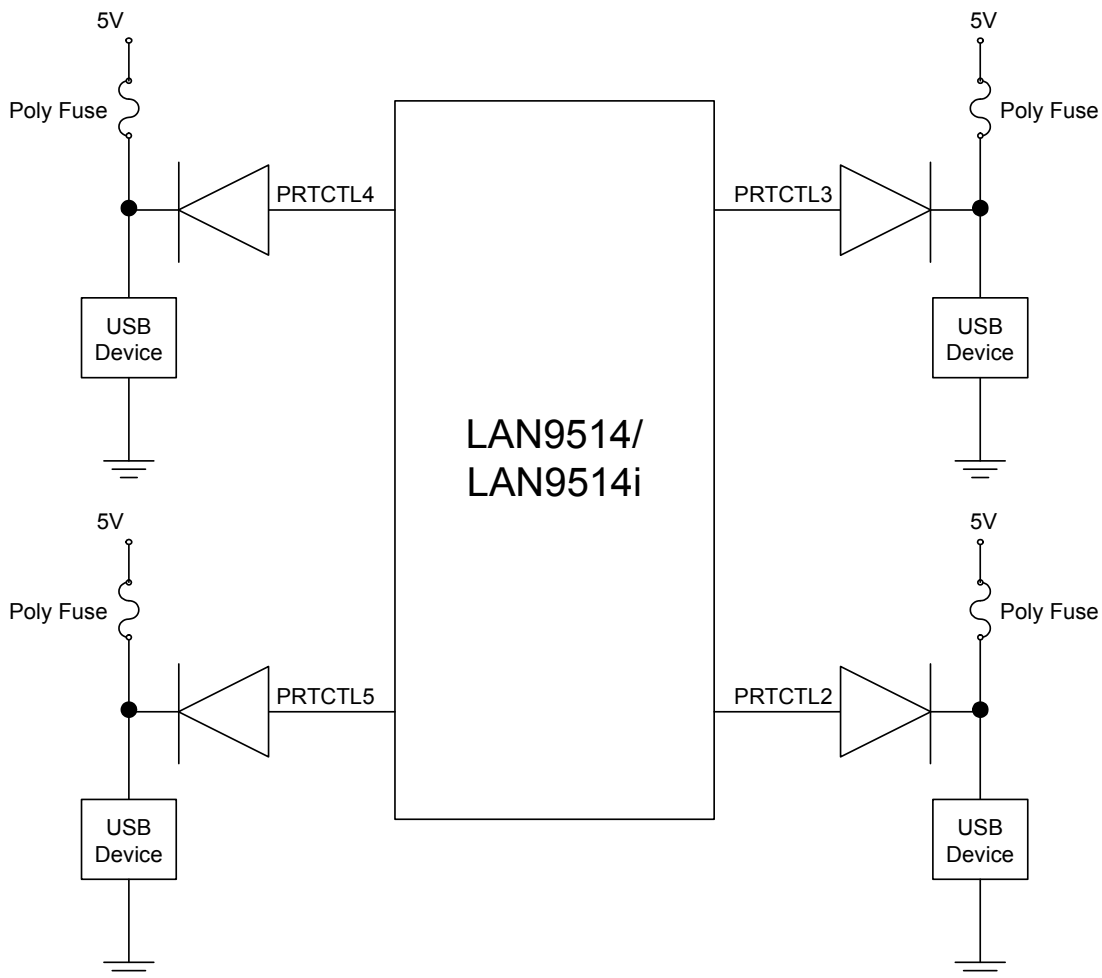

Figure 2.3 Port Power Control with USB Power Switch

## 2.2.2 Port Power Control Using a Poly Fuse

When using the LAN9514/LAN9514i with a poly fuse, an external diode must be used (See [Figure 2.4](#)). When disabling port power, the driver will drive a '0'. This procedure will have no effect since the external diode will isolate the pin from the load. When port power is enabled, the output driver is disabled and the pull-up resistor is enabled, which creates an open drain output. This means that the pull-up resistor is providing 3.3 volts to the anode of the diode. If there is an over-current situation, the poly fuse will open. This will cause the cathode of the diode to go to 0 volts. The anode of the diode will be at 0.7 volts, and the Schmidt trigger input will register this as a low, resulting in an overcurrent detection. The open drain output does not interfere.



**Figure 2.4 Port Power Control with Poly Fuse**

Datasheet

Many customers use a single poly fuse to power all their devices. For the ganged situation, all power control pins must be tied together.

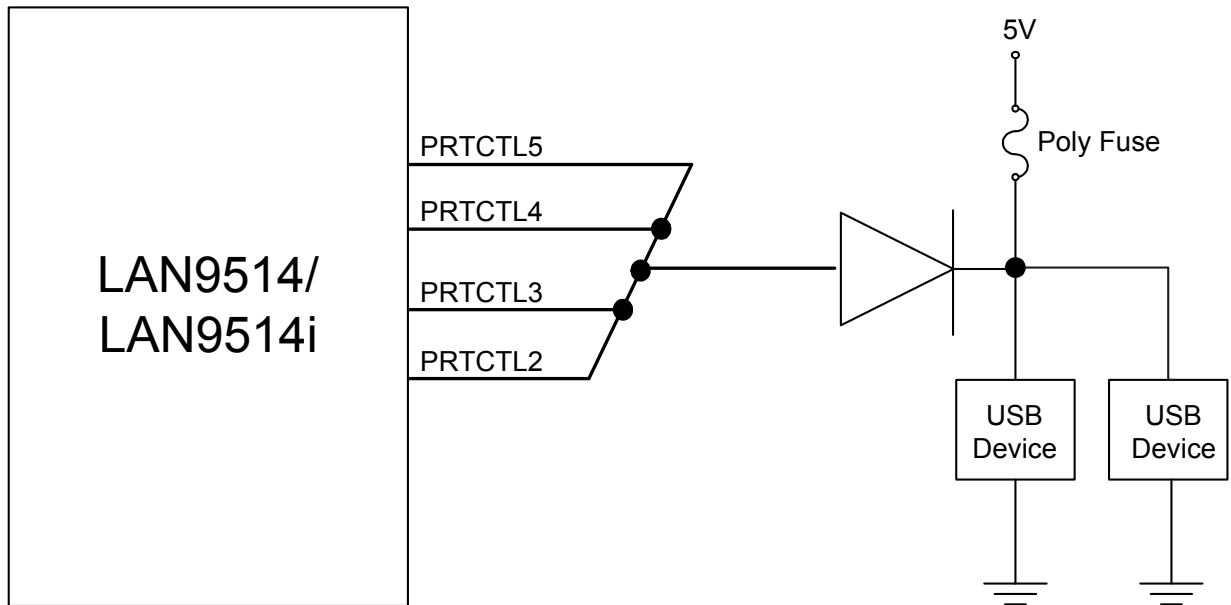

Figure 2.5 Port Power with Ganged Control with Poly Fuse

## 2.3 Buffer Types

**Table 2.8 Buffer Types**

BUFFER TYPE	DESCRIPTION
IS	Schmitt-triggered Input
IS_5V	5V Tolerant Schmitt-triggered Input
O8	Output with 8mA sink and 8mA source
OD8	Open-drain output with 8mA sink
O12	Output with 12mA sink and 12mA source
OD12	Open-drain output with 12mA sink
PU	50uA (typical) internal pull-up. Unless otherwise noted in the pin description, internal pull-ups are always enabled. <b>Note:</b> Internal pull-up resistors prevent unconnected inputs from floating. Do not rely on internal resistors to drive signals external to LAN9514/LAN9514i. When connected to a load that must be pulled high, an external resistor must be added.
PD	50uA (typical) internal pull-down. Unless otherwise noted in the pin description, internal pull-downs are always enabled. <b>Note:</b> Internal pull-down resistors prevent unconnected inputs from floating. Do not rely on internal resistors to drive signals external to LAN9514/LAN9514i. When connected to a load that must be pulled low, an external resistor must be added.
AI	Analog input
AIO	Analog bi-directional
ICLK	Crystal oscillator input pin
OCLK	Crystal oscillator output pin
P	Power pin

## Chapter 3 EEPROM Controller (EPC)

LAN9514/LAN9514i may use an external EEPROM to store the default values for the USB descriptors and the MAC address. The EEPROM controller supports most “93C46” type EEPROMs. A total of nine address bits are used to support 256/512 byte EEPROMs.

**Note:** A 3-wire style 2K/4K EEPROM that is organized for 256/512 x 8-bit operation must be used.

The MAC address is used as the default Ethernet MAC address and is loaded into the MAC’s ADDRH and ADDRL registers. If a properly configured EEPROM is not detected, it is the responsibility of the Host LAN Driver to set the IEEE addresses.

After a system-level reset occurs, the device will load the default values from a properly configured EEPROM. The device will not accept USB transactions from the Host until this process is completed.

The EEPROM controller also allows the Host system to read, write and erase the contents of the Serial EEPROM.

### 3.1 EEPROM Format

Table 3.1 illustrates the format in which data is stored inside of the EEPROM.

Note the EEPROM offsets are given in units of 16-bit word offsets. A length field with a value of zero indicates that the field does not exist in the EEPROM. The device will use the field’s HW default value in this case.

**Note:** For Device Descriptors, the only valid values for the length are 0 and 18.

**Note:** For Configuration and Interface Descriptors, the only valid values for the length are 0 and 18.

**Note:** The EEPROM programmer must ensure that if a String Descriptor does not exist in the EEPROM, the referencing descriptor must contain 00h for the respective string index field.

**Note:** If no Configuration Descriptor is present in the EEPROM, then the Configuration Flags affect the values of bmAttributes and bMaxPower in the Ethernet Controller Configuration Descriptor.

**Note:** If all String Descriptor lengths are zero, then a Language ID will not be supported.

**Table 3.1 EEPROM Format**

EEPROM ADDRESS	EEPROM CONTENTS
00h	0xA5
01h	MAC Address [7:0]
02h	MAC Address [15:8]
03h	MAC Address [23:16]
04h	MAC Address [31:24]
05h	MAC Address [39:32]
06h	MAC Address [47:40]
07h	Full-Speed Polling Interval for Interrupt Endpoint
08h	Hi-Speed Polling Interval for Interrupt Endpoint

**Table 3.1 EEPROM Format (continued)**

EEPROM ADDRESS	EEPROM CONTENTS
09h	Configuration Flags
0Ah	Language ID Descriptor [7:0]
0Bh	Language ID Descriptor [15:8]
0Ch	Manufacturer ID String Descriptor Length (bytes)
0Dh	Manufacturer ID String Descriptor EEPROM Word Offset
0Eh	Product Name String Descriptor Length (bytes)
0Fh	Product Name String Descriptor EEPROM Word Offset
10h	Serial Number String Descriptor Length (bytes)
11h	Serial Number String Descriptor EEPROM Word Offset
12h	Configuration String Descriptor Length (bytes)
13h	Configuration String Descriptor Word Offset
14h	Interface String Descriptor Length (bytes)
15h	Interface String Descriptor Word Offset
16h	Hi-Speed Device Descriptor Length (bytes)
17h	Hi-Speed Device Descriptor Word Offset
18h	Hi-Speed Configuration and Interface Descriptor Length (bytes)
19h	Hi-Speed Configuration and Interface Descriptor Word Offset
1Ah	Full-Speed Device Descriptor Length (bytes)
1Bh	Full-Speed Device Descriptor Word Offset
1Ch	Full-Speed Configuration and Interface Descriptor Length (bytes)
1Dh	Full-Speed Configuration and Interface Descriptor Word Offset
1Eh-1Fh	RESERVED
20h	Vendor ID LSB Register (VIDL)
21h	Vendor ID MSB Register (VIDM)
22h	Product ID LSB Register (PIDL)
23h	Product ID MSB Register (PIDM)
24h	Device ID LSB Register (DIDL)
25h	Device ID MSB Register (DIDM)
26h	Config Data Byte 1 Register (CFG1)
27h	Config Data Byte 2 Register (CFG2)
28h	Config Data Byte 3 Register (CFG3)
29h	Non-Removable Devices Register (NRD)

**Table 3.1 EEPROM Format (continued)**

EEPROM ADDRESS	EEPROM CONTENTS
2Ah	Port Disable (Self) Register (PDS)
2Bh	Port Disable (Bus) Register (PDB)
2Ch	Max Power (Self) Register (MAXPS)
2Dh	Max Power (Bus) Register (MAXPB)
2Eh	Hub Controller Max Current (Self) Register (HCMCS)
2Fh	Hub Controller Max Current (Bus) Register (HCMCB)
30h	Power-on Time Register (PWRT)
31h	Boost_Up Register (BOOSTUP)
32h	Boost_5 Register (BOOST5)
33h	Boost_4:2 Register (BOOST42)
34h	RESERVED
35h	Port Swap Register (PRTSP)
36h	Port Remap 12 Register (PRTR12)
37h	Port Remap 34 Register (PRTR34)
38h	Port Remap 5 Register (PRTR5)
39h	Status/Command Register (STCD)

**Note:** EEPROM byte addresses past 39h can be used to store data for any purpose.

[Table 3.2](#) describes the Configuration Flags

**Table 3.2 Configuration Flags Description**

BIT	NAME	DESCRIPTION
7:3	<b>RESERVED</b>	00000b
2	Remote Wakeup Support	0 = The device does not support remote wakeup. 1 = The device supports remote wakeup.
1	<b>RESERVED</b>	0b
0	Power Method	0 = The device Controller is bus powered. 1 = The device Controller is self powered.

### 3.1.1 Hub Configuration

EEPROM offsets 20h through 39h comprise the Hub Configuration parameters. [Table 3.3](#) describes these parameters and their default ROM values (Values assumed if no valid EEPROM present).

**Table 3.3 Hub Configuration**

EEPROM OFFSET	DESCRIPTION	DEFAULT
20h	<b>Vendor ID LSB Register (VIDL)</b> Least Significant Byte of the Vendor ID. This is a 16-bit value that uniquely identifies the Vendor of the user device (assigned by USB-Interface Forum).	24h
21h	<b>Vendor ID MSB Register (VIDM)</b> Most Significant Byte of the Vendor ID. This is a 16-bit value that uniquely identifies the Vendor of the user device (assigned by USB-Interface Forum).	04h
22h	<b>Product ID LSB Register (PIDL)</b> Least Significant Byte of the Product ID. This is a 16-bit value that the Vendor can assign that uniquely identifies this particular product (assigned by the OEM).	14h
23h	<b>Product ID MSB Register (PIDM)</b> Most Significant Byte of the Product ID. This is a 16-bit value that the Vendor can assign that uniquely identifies this particular product (assigned by the OEM).	95h
24h	<b>Device ID LSB Register (DIDL)</b> Least Significant Byte of the Device ID. This is a 16-bit device release number in BCD format (assigned by the OEM).	00h
25h	<b>Device ID MSB Register (DIDM)</b> Most Significant Byte of the Device ID. This is a 16-bit device release number in BCD format (assigned by the OEM).	<a href="#">Note 3.1</a>
26h	<b>Config Data Byte 1 Register (CFG1)</b> Refer to <a href="#">Table 3.4, "Config Data Byte 1 Register (CFG1) Format,"</a> on page 31 for details.	9Bh
27h	<b>Config Data Byte 2 Register (CFG2)</b> Refer to <a href="#">Table 3.5, "Config Data Byte 2 Register (CFG2) Format,"</a> on page 32 for details.	18h
28h	<b>Config Data Byte 3 Register (CFG3)</b> Refer to <a href="#">Table 3.6, "Config Data Byte 3 Register (CFG3) Format,"</a> on page 33 for details.	00h



Table 3.3 Hub Configuration (continued)

EEPROM OFFSET	DESCRIPTION	DEFAULT
29h	<p><b>Non-Removable Devices Register (NRD)</b> Indicates which port(s) include non-removable devices.</p> <p>0 = Port is removable 1 = Port is non-removable</p> <p>Informs the host if one of the active ports has a permanent device that is not detachable from the Hub.</p> <p><b>Note:</b> The device must provide its own descriptor data.</p> <p>Bit 7 = RESERVED Bit 6 = RESERVED Bit 5 = 1; Port 5 non-removable Bit 4 = 1; Port 4 non-removable Bit 3 = 1; Port 3 non-removable Bit 2 = 1; Port 2 non-removable Bit 1 = 1; Port 1 non-removable Bit 0 is RESERVED, always = 0b</p> <p><b>Note:</b> Bit 1 must be set to 1 by firmware for proper identification of the Ethernet Controller as a non-removable device.</p>	02h
2Ah	<p><b>Port Disable (Self) Register (PDS)</b> Disables 1 or more ports.</p> <p>0 = Port is available 1 = Port is disabled</p> <p>During Self-Powered operation, this selects the ports which will be permanently disabled, and are not available to be enabled or enumerated by a host controller. The ports can be disabled in any order, the internal logic will automatically report the correct number of enabled ports to the USB host, and will reorder the active ports in order to ensure proper function.</p> <p>Bit 7 = RESERVED Bit 6 = RESERVED Bit 5 = 1; Port 5 disabled Bit 4 = 1; Port 4 disabled Bit 3 = 1; Port 3 disabled Bit 2 = 1; Port 2 disabled Bit 1 = 1; Port 1 disabled Bit 0 is RESERVED, always = 0b</p>	00h
2Bh	<p><b>Port Disable (Bus) Register (PDB)</b> Disables 1 or more ports.</p> <p>0 = Port is available 1 = Port is disabled</p> <p>During Bus-Powered operation, this selects the ports which will be permanently disabled, and are not available to be enabled or enumerated by a host controller. The ports can be disabled in any order, the internal logic will automatically report the correct number of enabled ports to the USB host, and will reorder the active ports in order to ensure proper function.</p> <p>Bit 7 = RESERVED Bit 6 = RESERVED Bit 5 = 1; Port 5 disabled Bit 4 = 1; Port 4 disabled Bit 3 = 1; Port 3 disabled Bit 2 = 1; Port 2 disabled Bit 1 = 1; Port 1 disabled Bit 0 is RESERVED, always = 0b</p>	00h

**Table 3.3 Hub Configuration (continued)**

EEPROM OFFSET	DESCRIPTION	DEFAULT
2Ch	<b>Max Power (Self) Register (MAXPS)</b> Value in 2mA increments that the Hub consumes from an upstream port (VBUS) when operating as a self-powered hub. This value includes the hub silicon along with the combined power consumption (from VBUS) of all associated circuitry on the board. This value also includes the power consumption of a permanently attached peripheral if the hub is configured as a compound device, and the embedded peripheral reports 0mA in its descriptors. <b>Note:</b> The USB2.0 Specification does not permit this value to exceed 100mA.	01h
2Dh	<b>Max Power (Bus) Register (MAXPB)</b> Value in 2mA increments that the Hub consumes from an upstream port (VBUS) when operating as a bus-powered hub. This value includes the hub silicon along with the combined power consumption (from VBUS) of all associated circuitry on the board. This value also includes the power consumption of a permanently attached peripheral if the hub is configured as a compound device, and the embedded peripheral reports 0mA in its descriptors.	00h
2Eh	<b>Hub Controller Max Current (Self) Register (HCMCS)</b> Value in 2mA increments that the Hub consumes from an upstream port (VBUS) when operating as a self-powered hub. This value includes the hub silicon along with the combined power consumption (from VBUS) of all associated circuitry on the board. This value does NOT include the power consumption of a permanently attached peripheral if the hub is configured as a compound device. <b>Note:</b> The USB2.0 Specification does not permit this value to exceed 100mA.	01h
2Fh	<b>Hub Controller Max Current (Bus) Register (HCMCB)</b> Value in 2mA increments that the Hub consumes from an upstream port (VBUS) when operating as a bus-powered hub. This value includes the hub silicon along with the combined power consumption (from VBUS) of all associated circuitry on the board. This value does NOT include the power consumption of a permanently attached peripheral if the hub is configured as a compound device.	00h
30h	<b>Power-on Time Register (PWRT)</b> The length of time that it takes (in 2mS intervals) from the time the host initiated power-on sequence begins on a port until power is good on that port. System software uses this value to determine how long to wait before accessing a powered-on port.	32h
31h	<b>Boost_Up Register (BOOSTUP)</b> Refer to <a href="#">Table 3.7, "Boost_Up Register (BOOSTUP) Format,"</a> on page 33 for details.	00h
32h	<b>Boost_5 Register (BOOST5)</b> Refer to <a href="#">Table 3.8, "Boost_5 Register (BOOST5) Format,"</a> on page 33 for details.	00h
33h	<b>Boost_4:2 Register (BOOST42)</b> Refer to <a href="#">Table 3.9, "Boost_4:2 Register (BOOST42) Format,"</a> on page 34 for details.	00h
34h	<b>RESERVED</b>	00h

Table 3.3 Hub Configuration (continued)

EEPROM OFFSET	DESCRIPTION	DEFAULT
35h	<p><b>Port Swap Register (PRTSP)</b> Swaps the Upstream and Downstream USB DP and DM pins for ease of board routing to devices and connectors.</p> <p>0 = USB D+ functionality is associated with the DP pin and D- functionality is associated with the DM pin.</p> <p>1 = USB D+ functionality is associated with the DM pin and D- functionality is associated with the DP pin.</p> <p>Bit 7 = RESERVED            Bit 6 = RESERVED            Bit 5 = 1; Port 5 DP/DM is swapped            Bit 4 = 1; Port 4 DP/DM is swapped            Bit 3 = 1; Port 3 DP/DM is swapped            Bit 2 = 1; Port 2 DP/DM is swapped            Bit 1 = RESERVED            Bit 0 = 1; Upstream Port DP/DM is swapped</p>	00h

**Table 3.3 Hub Configuration (continued)**

EEPROM OFFSET	DESCRIPTION	DEFAULT																																										
36h	<p><b>Port Remap 12 Register (PRTR12)</b>            When a hub is enumerated by a USB Host Controller, the hub is only permitted to report how many ports it has. The hub is not permitted to select a numerical range or assignment. The Host Controller will number the downstream ports of the hub starting with the number 1, up to the number of ports that the hub reported having.</p> <p>The host's port number is referred to as "Logical Port Number" and the physical port on the hub is the "Physical Port Number". When remapping mode is enabled, (see <a href="#">Port Re-Mapping Enable (PRTMAP_EN)</a> bit in <a href="#">Config Data Byte 3 Register (CFG3) Format</a>) the hub's downstream port numbers can be remapped to different logical port numbers (assigned by the host).</p> <p><b>Note:</b> The OEM must ensure that Contiguous Logical Port Numbers are used, starting from #1 up to the maximum number of enabled ports. This ensures that the hub's ports are numbered in accordance with the way a Host will communicate with the ports.</p> <table border="1" data-bbox="342 804 1154 1507"> <tbody> <tr> <td>Bit [7:4] =</td> <td>0000</td> <td>Physical Port 2 is Disabled</td> </tr> <tr> <td></td> <td>0001</td> <td>Physical Port 2 is mapped to Logical Port 1</td> </tr> <tr> <td></td> <td>0010</td> <td>Physical Port 2 is mapped to Logical Port 2</td> </tr> <tr> <td></td> <td>0011</td> <td>Physical Port 2 is mapped to Logical Port 3</td> </tr> <tr> <td></td> <td>0100</td> <td>Physical Port 2 is mapped to Logical Port 4</td> </tr> <tr> <td></td> <td>0101</td> <td>Physical Port 2 is mapped to Logical Port 5</td> </tr> <tr> <td></td> <td></td> <td>All others RESERVED</td> </tr> <tr> <td>Bit [3:0] =</td> <td>0000</td> <td>Physical Port 1 is Disabled</td> </tr> <tr> <td></td> <td>0001</td> <td>Physical Port 1 is mapped to Logical Port 1</td> </tr> <tr> <td></td> <td>0010</td> <td>Physical Port 1 is mapped to Logical Port 2</td> </tr> <tr> <td></td> <td>0011</td> <td>Physical Port 1 is mapped to Logical Port 3</td> </tr> <tr> <td></td> <td>0100</td> <td>Physical Port 1 is mapped to Logical Port 4</td> </tr> <tr> <td></td> <td>0101</td> <td>Physical Port 1 is mapped to Logical Port 5</td> </tr> <tr> <td></td> <td></td> <td>All others RESERVED</td> </tr> </tbody> </table>	Bit [7:4] =	0000	Physical Port 2 is Disabled		0001	Physical Port 2 is mapped to Logical Port 1		0010	Physical Port 2 is mapped to Logical Port 2		0011	Physical Port 2 is mapped to Logical Port 3		0100	Physical Port 2 is mapped to Logical Port 4		0101	Physical Port 2 is mapped to Logical Port 5			All others RESERVED	Bit [3:0] =	0000	Physical Port 1 is Disabled		0001	Physical Port 1 is mapped to Logical Port 1		0010	Physical Port 1 is mapped to Logical Port 2		0011	Physical Port 1 is mapped to Logical Port 3		0100	Physical Port 1 is mapped to Logical Port 4		0101	Physical Port 1 is mapped to Logical Port 5			All others RESERVED	21h
Bit [7:4] =	0000	Physical Port 2 is Disabled																																										
	0001	Physical Port 2 is mapped to Logical Port 1																																										
	0010	Physical Port 2 is mapped to Logical Port 2																																										
	0011	Physical Port 2 is mapped to Logical Port 3																																										
	0100	Physical Port 2 is mapped to Logical Port 4																																										
	0101	Physical Port 2 is mapped to Logical Port 5																																										
		All others RESERVED																																										
Bit [3:0] =	0000	Physical Port 1 is Disabled																																										
	0001	Physical Port 1 is mapped to Logical Port 1																																										
	0010	Physical Port 1 is mapped to Logical Port 2																																										
	0011	Physical Port 1 is mapped to Logical Port 3																																										
	0100	Physical Port 1 is mapped to Logical Port 4																																										
	0101	Physical Port 1 is mapped to Logical Port 5																																										
		All others RESERVED																																										

**Table 3.3 Hub Configuration (continued)**

EEPROM OFFSET	DESCRIPTION	DEFAULT																																										
37h	<p><b>Port Remap 34 Register (PRTR34)</b>                      When a hub is enumerated by a USB Host Controller, the hub is only permitted to report how many ports it has. The hub is not permitted to select a numerical range or assignment. The Host Controller will number the downstream ports of the hub starting with the number 1, up to the number of ports that the hub reported having.</p> <p>The host's port number is referred to as "Logical Port Number" and the physical port on the hub is the "Physical Port Number". When remapping mode is enabled (see <a href="#">Port Re-Mapping Enable (PRTMAP_EN)</a> bit in <a href="#">Config Data Byte 3 Register (CFG3) Format</a>), the hub's downstream port numbers can be remapped to different logical port numbers (assigned by the host).</p> <p><b>Note:</b> The OEM must ensure that Contiguous Logical Port Numbers are used, starting from #1 up to the maximum number of enabled ports, this ensures that the hub's ports are numbered in accordance with the way a Host will communicate with the ports.</p> <table border="1" data-bbox="342 802 1154 1507"> <tbody> <tr> <td>Bit [7:4] =</td> <td>0000</td> <td>Physical Port 4 is Disabled</td> </tr> <tr> <td></td> <td>0001</td> <td>Physical Port 4 is mapped to Logical Port 1</td> </tr> <tr> <td></td> <td>0010</td> <td>Physical Port 4 is mapped to Logical Port 2</td> </tr> <tr> <td></td> <td>0011</td> <td>Physical Port 4 is mapped to Logical Port 3</td> </tr> <tr> <td></td> <td>0100</td> <td>Physical Port 4 is mapped to Logical Port 4</td> </tr> <tr> <td></td> <td>0101</td> <td>Physical Port 4 is mapped to Logical Port 5</td> </tr> <tr> <td></td> <td></td> <td>All others RESERVED</td> </tr> <tr> <td>Bit [3:0] =</td> <td>0000</td> <td>Physical Port 3 is Disabled</td> </tr> <tr> <td></td> <td>0001</td> <td>Physical Port 3 is mapped to Logical Port 1</td> </tr> <tr> <td></td> <td>0010</td> <td>Physical Port 3 is mapped to Logical Port 2</td> </tr> <tr> <td></td> <td>0011</td> <td>Physical Port 3 is mapped to Logical Port 3</td> </tr> <tr> <td></td> <td>0100</td> <td>Physical Port 3 is mapped to Logical Port 4</td> </tr> <tr> <td></td> <td>0101</td> <td>Physical Port 3 is mapped to Logical Port 5</td> </tr> <tr> <td></td> <td></td> <td>All others RESERVED</td> </tr> </tbody> </table>	Bit [7:4] =	0000	Physical Port 4 is Disabled		0001	Physical Port 4 is mapped to Logical Port 1		0010	Physical Port 4 is mapped to Logical Port 2		0011	Physical Port 4 is mapped to Logical Port 3		0100	Physical Port 4 is mapped to Logical Port 4		0101	Physical Port 4 is mapped to Logical Port 5			All others RESERVED	Bit [3:0] =	0000	Physical Port 3 is Disabled		0001	Physical Port 3 is mapped to Logical Port 1		0010	Physical Port 3 is mapped to Logical Port 2		0011	Physical Port 3 is mapped to Logical Port 3		0100	Physical Port 3 is mapped to Logical Port 4		0101	Physical Port 3 is mapped to Logical Port 5			All others RESERVED	43h
Bit [7:4] =	0000	Physical Port 4 is Disabled																																										
	0001	Physical Port 4 is mapped to Logical Port 1																																										
	0010	Physical Port 4 is mapped to Logical Port 2																																										
	0011	Physical Port 4 is mapped to Logical Port 3																																										
	0100	Physical Port 4 is mapped to Logical Port 4																																										
	0101	Physical Port 4 is mapped to Logical Port 5																																										
		All others RESERVED																																										
Bit [3:0] =	0000	Physical Port 3 is Disabled																																										
	0001	Physical Port 3 is mapped to Logical Port 1																																										
	0010	Physical Port 3 is mapped to Logical Port 2																																										
	0011	Physical Port 3 is mapped to Logical Port 3																																										
	0100	Physical Port 3 is mapped to Logical Port 4																																										
	0101	Physical Port 3 is mapped to Logical Port 5																																										
		All others RESERVED																																										

**Table 3.3 Hub Configuration (continued)**

EEPROM OFFSET	DESCRIPTION	DEFAULT																								
38h	<p><b>Port Remap 5 Register (PRTR5)</b>            When a hub is enumerated by a USB Host Controller, the hub is only permitted to report how many ports it has. The hub is not permitted to select a numerical range or assignment. The Host Controller will number the downstream ports of the hub starting with the number 1, up to the number of ports that the hub reported having.</p> <p>The host's port number is referred to as "Logical Port Number" and the physical port on the hub is the "Physical Port Number". When remapping mode is enabled (see <a href="#">Port Re-Mapping Enable (PRTMAP_EN)</a> bit in <a href="#">Config Data Byte 3 Register (CFG3) Format</a>) the hub's downstream port numbers can be remapped to different logical port numbers (assigned by the host).</p> <p><b>Note:</b> The OEM must ensure that Contiguous Logical Port Numbers are used, starting from #1 up to the maximum number of enabled ports, this ensures that the hub's ports are numbered in accordance with the way a Host will communicate with the ports.</p> <table border="1" data-bbox="344 814 1156 1213"> <tbody> <tr> <td>Bit [7:4] =</td> <td>-</td> <td>RESERVED</td> </tr> <tr> <td>Bit [3:0] =</td> <td>0000</td> <td>Physical Port 5 is Disabled</td> </tr> <tr> <td></td> <td>0001</td> <td>Physical Port 5 is mapped to Logical Port 1</td> </tr> <tr> <td></td> <td>0010</td> <td>Physical Port 5 is mapped to Logical Port 2</td> </tr> <tr> <td></td> <td>0011</td> <td>Physical Port 5 is mapped to Logical Port 3</td> </tr> <tr> <td></td> <td>0100</td> <td>Physical Port 5 is mapped to Logical Port 4</td> </tr> <tr> <td></td> <td>0101</td> <td>Physical Port 5 is mapped to Logical Port 5</td> </tr> <tr> <td></td> <td></td> <td>All others RESERVED</td> </tr> </tbody> </table>	Bit [7:4] =	-	RESERVED	Bit [3:0] =	0000	Physical Port 5 is Disabled		0001	Physical Port 5 is mapped to Logical Port 1		0010	Physical Port 5 is mapped to Logical Port 2		0011	Physical Port 5 is mapped to Logical Port 3		0100	Physical Port 5 is mapped to Logical Port 4		0101	Physical Port 5 is mapped to Logical Port 5			All others RESERVED	05h
Bit [7:4] =	-	RESERVED																								
Bit [3:0] =	0000	Physical Port 5 is Disabled																								
	0001	Physical Port 5 is mapped to Logical Port 1																								
	0010	Physical Port 5 is mapped to Logical Port 2																								
	0011	Physical Port 5 is mapped to Logical Port 3																								
	0100	Physical Port 5 is mapped to Logical Port 4																								
	0101	Physical Port 5 is mapped to Logical Port 5																								
		All others RESERVED																								
39h	<p><b>Status/Command Register (STCD)</b>            Refer to <a href="#">Table 3.10, "Status/Command Register (STCD) Format,"</a> on page 34 for details.</p>	01h																								

**Note 3.1** Default value is dependent on device revision.

Table 3.4 Config Data Byte 1 Register (CFG1) Format

BITS	DESCRIPTION	DEFAULT
7	<p><b>Self or Bus Power (SELF_BUS_PWR)</b> Selects between Self or Bus-Powered operation.</p> <p>0 = Bus-Powered 1 = Self-Powered</p> <p>The Hub is either Self-Powered (draws less than 2mA of upstream bus power) or Bus-Powered (limited to a 100mA maximum of upstream power prior to being configured by the host controller).</p> <p>When configured as a Bus-Powered device, the SMSC Hub consumes less than 100mA of current prior to being configured. After configuration, the Bus-Powered SMSC Hub (along with all associated hub circuitry, any embedded devices if part of a compound device, and 100mA per externally available downstream port) must consume no more than 500mA of upstream VBUS current. The current consumption is system dependent, and the OEM must ensure that the USB2.0 specifications are not violated.</p> <p>When configured as a Self-Powered device, &lt;1mA of upstream VBUS current is consumed and all ports are available, with each port being capable of sourcing 500mA of current.</p>	1b
6	<b>RESERVED</b>	0b
5	<p><b>High Speed Disable (HS_DISABLE)</b> Disables the capability to attach as either a High/Full-Speed device, and forces attachment as Full-Speed only (no High-Speed support).</p> <p>0 = High-/Full-Speed 1 = Full-Speed-Only (High-Speed disabled)</p>	0b
4	<p><b>Multiple TT Enable (MTT_ENABLE)</b> Enables one transaction translator per port operation.</p> <p>Selects between a mode where only one transaction translator is available for all ports (Single-TT), or each port gets a dedicated transaction translator (Multi-TT) {Note: The host may force Single-TT mode only}.</p> <p>0 = Single TT for all ports. 1 = One TT per port (multiple TT's supported)</p>	1b
3	<p><b>EOP Disable (EOP_DISABLE)</b> Disables EOP generation of EOF1 when in Full-Speed mode. During FS operation only, this permits the Hub to send EOP if no downstream traffic is detected at EOF1. See Section 11.3.1 of the USB 2.0 Specification for additional details.</p> <p><b>Note:</b> Generation of an EOP at the EOF1 point may prevent a Host controller (operating in FS mode) from placing the USB bus in suspend.</p> <p>0 = An EOP is generated at the EOF1 point if no traffic is detected. 1 = EOP generation at EOF1 is disabled (note: this is normal USB operation).</p> <p><b>Note:</b> This is a rarely used feature in the PC environment, existing drivers may not have been thoroughly debugged with this feature enabled. It is included because it is a permitted feature in Chapter 11 of the USB specification.</p>	1b

**Table 3.4 Config Data Byte 1 Register (CFG1) Format (continued)**

<b>BITS</b>	<b>DESCRIPTION</b>	<b>DEFAULT</b>
2:1	<p><b>Over Current Sense (CURRENT_SNS)</b>            Selects current sensing on a port-by-port basis, all ports ganged, or none (only for bus-powered hubs) The ability to support current sensing on a port or ganged basis is hardware implementation dependent.</p> <p>00 = Ganged sensing (all ports together)            01 = Individual port-by-port            1x = Over current sensing not supported (must only be used with Bus- Powered configurations!)</p>	01b
0	<p><b>Port Power Switching (PORT_PWR)</b>            Enables power switching on all ports simultaneously (ganged), or port power is individually switched on and off on a port by port basis (individual). The ability to support power enabling on a port or ganged basis is hardware implementation dependent.</p> <p>0 = Ganged switching (all ports together)            1 = Individual port by port switching</p>	1b

**Table 3.5 Config Data Byte 2 Register (CFG2) Format**

<b>BITS</b>	<b>DESCRIPTION</b>	<b>DEFAULT</b>
7:6	<b>RESERVED</b>	00b
5:4	<p><b>Over Current Timer (OC_TIMER)</b>            Over Current Timer delay</p> <p>00 = 50ns            01 = 100ns (This is the recommended value)            10 = 200ns            11 = 400ns</p>	01b
3	<p><b>Compound Device (COMPOUND)</b>            Allows the OEM to indicate that the Hub is part of a compound (see the USB Specification for definition) device. The applicable port(s) must also be defined as having a "Non-Removable Device".</p> <p>0 = No            1 = Yes, Hub is part of a compound device</p>	1b
2:0	<b>RESERVED</b>	000b



Table 3.6 Config Data Byte 3 Register (CFG3) Format

BITS	DESCRIPTION	DEFAULT
7:4	<b>RESERVED</b>	0h
3	<p><b>Port Re-Mapping Enable (PRTMAP_EN)</b> Selects the method used by the Hub to assign port numbers and disable ports.</p> <p>0 = Standard Mode. The following EEPROM addresses are used to define which ports are enabled. The ports mapped as Port'n' on the Hub are reported as Port'n' to the host, unless one of the ports is disabled, then the higher numbered ports are remapped in order to report contiguous port numbers to the host.</p> <p>EEPROM Address 2Ah: Port Disable for Self-Powered operation EEPROM Address 2Bh: Port Disable for Bus-Powered operation</p> <p>1 = Port Re-Map mode. The mode enables remapping via the following EEPROM addresses:</p> <p>EEPROM Address 36h: Port Remap 12 EEPROM Address 37h: Port Remap 34 EEPROM Address 38h: Port Remap 5</p>	0b
2:0	<b>RESERVED</b>	000b

Table 3.7 Boost\_Up Register (BOOSTUP) Format

BITS	DESCRIPTION	DEFAULT
7:2	<b>RESERVED</b>	000000b
1:0	<p><b>Upstream USB Electrical Signaling Drive Strength Boost Bit for Upstream Port A (BOOST_IOUT_A)</b></p> <p>00 = Normal electrical drive strength 01 = Elevated electrical drive strength (+4% boost) 10 = Elevated electrical drive strength (+8% boost) 11 = Elevated electrical drive strength (+12% boost)</p>	00b

Table 3.8 Boost\_5 Register (BOOST5) Format

BITS	DESCRIPTION	DEFAULT
7:2	<b>RESERVED</b>	000000b
1:0	<p><b>Upstream USB Electrical Signaling Drive Strength Boost Bit for Downstream Port 5 (BOOST_IOUT_5)</b></p> <p>00 = Normal electrical drive strength 01 = Elevated electrical drive strength (+4% boost) 10 = Elevated electrical drive strength (+8% boost) 11 = Elevated electrical drive strength (+12% boost)</p>	00b

**Table 3.9 Boost\_4:2 Register (BOOST42) Format**

<b>BITS</b>	<b>DESCRIPTION</b>	<b>DEFAULT</b>
7:6	<b>Upstream USB Electrical Signaling Drive Strength Boost Bit for Downstream Port 4 (BOOST_IOUT_4)</b>  00 = Normal electrical drive strength 01 = Elevated electrical drive strength (+4% boost) 10 = Elevated electrical drive strength (+8% boost) 11 = Elevated electrical drive strength (+12% boost)	00b
5:4	<b>Upstream USB Electrical Signaling Drive Strength Boost Bit for Downstream Port 3 (BOOST_IOUT_3)</b>  00 = Normal electrical drive strength 01 = Elevated electrical drive strength (+4% boost) 10 = Elevated electrical drive strength (+8% boost) 11 = Elevated electrical drive strength (+12% boost)	00b
3:2	<b>Upstream USB Electrical Signaling Drive Strength Boost Bit for Downstream Port 2 (BOOST_IOUT_2)</b>  00 = Normal electrical drive strength 01 = Elevated electrical drive strength (+4% boost) 10 = Elevated electrical drive strength (+8% boost) 11 = Elevated electrical drive strength (+12% boost)	00b
1:0	<b>RESERVED</b>	00b

**Table 3.10 Status/Command Register (STCD) Format**

<b>BITS</b>	<b>DESCRIPTION</b>	<b>DEFAULT</b>
7:2	<b>RESERVED</b>	000000b
1	<b>Reset (RESET)</b> Resets the internal memory back to nRESET assertion default settings.  0 = Normal Run/Idle State 1 = Force a reset of the registers to their default state  <b>Note:</b> During this reset, this bit is automatically cleared to its default value of 0.	0b
0	<b>USB Attach and Write Protect (USB_ATTACH)</b>  0 = Device is in configuration state 1 = Hub will signal a USB attach event to an upstream device, and the internal memory (address range 00h - FEh) is "write-protected" to prevent unintentional data corruption.  <b>Note:</b> This bit is write once and is only cleared by assertion of the external nRESET or POR.	1b

## 3.2 EEPROM Defaults

The signature value of 0xA5 is stored at address 0. A different signature value indicates to the EEPROM controller that no EEPROM or an un-programmed EEPROM is attached to the device. In this case, the hardware default values are used, as shown in [Table 3.11](#).

**Table 3.11 EEPROM Defaults**

FIELD	DEFAULT VALUE
Ethernet Controller MAC Address	FFFFFFFFFFFFh
Ethernet Controller Full-Speed Polling Interval (mS)	01h
Ethernet Controller Hi-Speed Polling Interval (mS)	04h
Ethernet Controller Configuration Flags	05h
Ethernet Controller Maximum Power (mA)	01h
Ethernet Controller Vendor ID	0424h
Ethernet Controller Product ID	EC00h

## 3.3 EEPROM Auto-Load

Certain system level resets (USB reset, POR, nRESET, and SRST) cause the EEPROM contents to be loaded into the device. After a reset, the EEPROM controller attempts to read the first byte of data from the EEPROM. If the value 0xA5 is read from the first address, then the EEPROM controller will assume that the external Serial EEPROM is configured for auto-loading. If a value other than 0xA5 is read from the first address, the EEPROM auto-load will not commence.

**Note:** The EEPROM contents are loaded for both the Hub and the Ethernet Controller as a result of a POR or nRESET. The USB reset results only in the loading of the MAC address from the EEPROM. A software reset (SRST) or a EEPROM Reload Command causes the EEPROM contents related solely to the Ethernet Controller to be loaded.

### 3.4 An Example of EEPROM Format Interpretation

Table 3.12 and Table 3.13 provide an example of how the contents of a EEPROM are formatted. Table 3.12 is a dump of the EEPROM memory (256-byte EEPROM), while Table 3.13 illustrates, byte by byte, how the EEPROM is formatted.

**Table 3.12 Dump of EEPROM Memory**

OFFSET BYTE	VALUE
0000h	A5 12 34 56 78 9A BC 01
0008h	04 05 09 04 0A 1D 00 00
0010h	00 00 00 00 00 00 12 22
0018h	12 2B 12 34 12 3D 00 00
0020h	24 04 14 95 00 01 9B 18
0028h	00 02 00 00 01 00 01 00
0030h	32 00 00 00 00 00 21 43
0038h	05 01 0A 03 53 00 4D 00
0040h	53 00 43 00 12 01 00 02
0048h	FF 00 01 40 24 04 00 EC
0050h	00 01 01 00 00 01 09 02
0058h	27 00 01 01 00 E0 01 09
0060h	04 00 00 03 FF 00 FF 00
0068h	12 01 00 02 FF 00 FF 40
0070h	24 04 00 EC 00 01 01 00
0078h	00 01 09 02 27 00 01 01
0080h	00 E0 01 09 04 00 00 03
0088h	FF 00 FF 00 .....
0090h - 00FFh	.....

**Table 3.13 EEPROM Example - 256 Byte EEPROM**

<b>EEPROM ADDRESS</b>	<b>EEPROM CONTENTS (HEX)</b>	<b>DESCRIPTION</b>
00h	A5	EEPROM Programmed Indicator
01h-06h	12 34 56 78 9A BC	MAC Address 12 34 56 78 9A BC
07h	01	Full-Speed Polling Interval for Interrupt Endpoint (1ms)
08h	04	Hi-Speed Polling Interval for Interrupt Endpoint (4ms)
09h	05	Configuration Flags - The device is self powered and supports remote wakeup.
0Ah-0Bh	09 04	Language ID Descriptor 0409h, English
0Ch	0A	Manufacturer ID String Descriptor Length (10 bytes)
0Dh	1D	Manufacturer ID String Descriptor EEPROM Word Offset (1Dh) Corresponds to EEPROM Byte Offset 3Ah
0Eh	00	Product Name String Descriptor Length (0 bytes - NA)
0Fh	00	Product Name String Descriptor EEPROM Word Offset (Don't Care)
10h	00	Serial Number String Descriptor Length (0 bytes - NA)
11h	00	Serial Number String Descriptor EEPROM Word Offset (Don't Care)
12h	00	Configuration String Descriptor Length (0 bytes - NA)
13h	00	Configuration String Descriptor Word Offset (Don't Care)
14h	00	Interface String Descriptor Length (0 bytes - NA)
15h	00	Interface String Descriptor Word Offset (Don't Care)
16h	12	Hi-Speed Device Descriptor Length (18 bytes)
17h	22h	Hi-Speed Device Descriptor Word Offset (22h) Corresponds to EEPROM Byte Offset 44h
18h	12	Hi-Speed Configuration and Interface Descriptor Length (18 bytes)
19h	2B	Hi-Speed Configuration and Interface Descriptor Word Offset (2Bh) Corresponds to EEPROM Byte Offset 56h
1Ah	12	Full-Speed Device Descriptor Length (18 bytes)
1Bh	34	Full-Speed Device Descriptor Word Offset (34h) Corresponds to EEPROM Byte Offset 68h
1Ch	12	Full-Speed Configuration and Interface Descriptor Length (18bytes)
1Dh	3D	Full-Speed Configuration and Interface Descriptor Word Offset (3Dh) Corresponds to EEPROM Byte Offset 7Ah
1Eh	00	RESERVED
1Fh	00	RESERVED
20h	24	Vendor ID LSB Register (VIDL)

**Table 3.13 EEPROM Example - 256 Byte EEPROM (continued)**

<b>EEPROM ADDRESS</b>	<b>EEPROM CONTENTS (HEX)</b>	<b>DESCRIPTION</b>
21h	04	Vendor ID MSB Register (VIDM)
22h	14	Product ID LSB Register (PIDL)
23h	95	Product ID MSB Register (PIDM)
24h	00	Device ID LSB Register (DIDL)
25h	01	Device ID MSB Register (DIDM)
26h	9B	Config Data Byte 1 Register (CFG1)
27h	18	Config Data Byte 2 Register (CFG2)
28h	00	Config Data Byte 3 Register (CFG3)
29h	02	Non-Removable Devices Register (NRD)
2Ah	00	Port Disable (Self) Register (PDS)
2Bh	00	Port Disable (Bus) Register (PDB)
2Ch	01	Max Power (Self) Register (MAXPS)
2Dh	00	Max Power (Bus) Register (MAXPB)
2Eh	01	Hub Controller Max Current (Self) Register (HCMCS)
2Fh	00	Hub Controller Max Current (Bus) Register (HCMCB)
30h	32	Power-on Time Register (PWRT)
31h	00	Boost_Up Register (BOOSTUP)
32h	00	Boost_7:5 Register (BOOST75)
33h	00	Boost_4:2 Register (BOOST42)
34h	00	RESERVED
35h	00	Port Swap Register (PRTSP)
36h	21	Port Remap 12 Register (PRTR12)
37h	43	Port Remap 34 Register (PRTR34)
38h	05	Port Remap 5 Register (PRTR5)
39h	01	Status/Command Register (STCD)
3A	0A	Size of Manufacturer ID String Descriptor (10 bytes)
3Bh	03	Descriptor Type (String Descriptor - 03h)
3Ch-43h	53 00 4D 00 53 00 43 00	Manufacturer ID String ("SMSC" in UNICODE)
44h	12	Size of Hi-Speed Device Descriptor in Bytes (18 bytes)
45h	01	Descriptor Type (Device Descriptor - 01h)
46h-47h	00 02	USB Specification Number that the device complies with (0200h)

Table 3.13 EEPROM Example - 256 Byte EEPROM (continued)

EEPROM ADDRESS	EEPROM CONTENTS (HEX)	DESCRIPTION
48h	FF	Class Code
49h	00	Subclass Code
4Ah	FF	Protocol Code
4Bh	40	Maximum Packet Size for Endpoint 0
4Ch-4Dh	24 04	Vendor ID (0424h)
4Eh-4Fh	00 EC	Product ID (EC00h)
50h-51h	00 01	Device Release Number (0100h)
52h	01	Index of Manufacturer String Descriptor
53h	00	Index of Product String Descriptor
54h	00	Index of Serial Number String Descriptor
55h	01	Number of Possible Configurations
56h	09	Size of Hi-Speed Configuration Descriptor in bytes (9 bytes)
57h	02	Descriptor Type (Configuration Descriptor - 02h)
58h-59h	27 00	Total length in bytes of data returned (0027h = 39 bytes)
5Ah	01	Number of Interfaces
5Bh	01	Value to use as an argument to select this configuration
5Ch	00	Index of String Descriptor describing this configuration
5Dh	E0	Self powered and remote wakeup enabled
5Eh	01	Maximum Power Consumption is 2 mA
5Fh	09	Size of Descriptor in Bytes (9 Bytes)
60h	04	Descriptor Type (Interface Descriptor - 04h)
61h	00	Number identifying this Interface
62h	00	Value used to select alternative setting
63h	03	Number of Endpoints used for this interface (Less endpoint 0)
64h	FF	Class Code
65h	00	Subclass Code
66h	FF	Protocol Code
67h	00	Index of String Descriptor Describing this interface
68h	12	Size of Full-Speed Device Descriptor in Bytes (18 Bytes)
69h	01	Descriptor Type (Device Descriptor - 01h)
6Ah-6Bh	00 02	USB Specification Number that the device complies with (0200h)

**Table 3.13 EEPROM Example - 256 Byte EEPROM (continued)**

<b>EEPROM ADDRESS</b>	<b>EEPROM CONTENTS (HEX)</b>	<b>DESCRIPTION</b>
6Ch	FF	Class Code
6Dh	00	Subclass Code
6Eh	FF	Protocol Code
6Fh	40	Maximum Packet Size for Endpoint 0
70h-71h	24 04	Vendor ID (0424h)
72h-73h	00 EC	Product ID (EC00h)
74h-75h	00 01	Device Release Number (0100h)
76	01	Index of Manufacturer String Descriptor
77h	00	Index of Product String Descriptor
78h	00	Index of Serial Number String Descriptor
79h	01	Number of Possible Configurations
7Ah	09	Size of Full-Speed Configuration Descriptor in bytes (9 bytes)
7Bh	02	Descriptor Type (Configuration Descriptor - 02h)
7Ch-7Dh	27 00	Total length in bytes of data returned (0027h = 39 bytes)
7Eh	01	Number of Interfaces
7Fh	01	Value to use as an argument to select this configuration
80h	00	Index of String Descriptor describing this configuration
81h	E0	Self powered and remote wakeup enabled
82h	01	Maximum Power Consumption is 2 mA
83h	09	Size of Full-Speed Interface Descriptor in Bytes (9 Bytes)
84h	04	Descriptor Type (Interface Descriptor - 04h)
85h	00	Number identifying this Interface
86h	00	Value used to select alternative setting
87h	03	Number of Endpoints used for this interface (Less endpoint 0)
88h	FF	Class Code
89h	00	Subclass Code
8Ah	FF	Protocol Code
8Bh	00	Index of String Descriptor describing this interface
8Ch-FFh	-	Data storage for use by Host as desired



## Chapter 4 Operational Characteristics

### 4.1 Absolute Maximum Ratings\*

Supply Voltage (VDD33IO, VDD33A) (Note 4.1)	0V to +3.6V
Positive voltage on signal pins, with respect to ground (Note 4.2)	+6V
Negative voltage on signal pins, with respect to ground (Note 4.3)	-0.5V
Positive voltage on XI, with respect to ground	+4.6V
Positive voltage on XO, with respect to ground	+2.5V
Ambient Operating Temperature in Still Air (T <sub>A</sub> )	Note 4.4
Storage Temperature	-55°C to +150°C
Lead Temperature Range	Refer to JEDEC Spec. J-STD-020
HBM ESD Performance per JESD 22-A114-E	+/- 8kV
Contact Discharge ESD Performance per IEC61000-4-2 (Note 4.5)	+/- 8kV
Air-Gap Discharge ESD Performance per IEC61000-4-2 (Note 4.5)	+/- 15kV
Latch-up Performance per EIA/JESD 78	+/- 200mA

**Note 4.1** When powering this device from laboratory or system power supplies, it is important that the absolute maximum ratings not be exceeded or device failure can result. Some power supplies exhibit voltage spikes on their outputs when AC power is switched on or off. In addition, voltage transients on the AC power line may appear on the DC output. If this possibility exists, it is suggested that a clamp circuit be used.

**Note 4.2** This rating does not apply to the following pins: XI, XO, EXRES, USBRBIAS.

**Note 4.3** This rating does not apply to the following pins: EXRES, USBRBIAS.

**Note 4.4** 0°C to +70°C for commercial version, -40°C to +85°C for industrial version.

**Note 4.5** Performed by independent 3rd party test facility.

\*Stresses exceeding those listed in this section could cause permanent damage to the device. This is a stress rating only. Exposure to absolute maximum rating conditions for extended periods may affect device reliability. Functional operation of the device at any condition exceeding those indicated in Section 4.2, "Operating Conditions\*\*", Section 4.4, "DC Specifications", or any other applicable section of this specification is not implied. Note, device signals are *NOT* 5 volt tolerant unless specified otherwise.

### 4.2 Operating Conditions\*\*

Supply Voltage (VDD33A, VDD33BIAS, VDD33IO)	+3.3V +/- 300mV
Ambient Operating Temperature in Still Air (T <sub>A</sub> )	Note 4.4

\*\*Proper operation of LAN9514/LAN9514i is guaranteed only within the ranges specified in this section.

## 4.3 Power Consumption

This section details the power consumption of the device as measured during various modes of operation. Power dissipation is determined by temperature, supply voltage, and external source/sink requirements.

### 4.3.1 SUSPEND0

**Table 4.1 SUSPEND0 Current Consumption and Power Dissipation (VDD33IO = VDD33A = 3.3V)**

PARAMETER	MIN	TYPICAL	MAX	UNIT
Supply current (VDD33IO, VDD33A)		74		mA
Power Dissipation (Device Only)		245		mW
Power Dissipation (Device and Ethernet components)		379		mW

### 4.3.2 SUSPEND1

**Table 4.2 SUSPEND1 Current Consumption and Power Dissipation (VDD33IO = VDD33A = 3.3V)**

PARAMETER	MIN	TYPICAL	MAX	UNIT
Supply current (VDD33IO, VDD33A)		68		mA
Power Dissipation (Device Only)		224		mW
Power Dissipation (Device and Ethernet components)		229		mW

### 4.3.3 SUSPEND2

**Table 4.3 SUSPEND2 Current Consumption and Power Dissipation (VDD33IO = VDD33A = 3.3V)**

PARAMETER	MIN	TYPICAL	MAX	UNIT
Supply current (VDD33IO, VDD33A)		4.2		mA
Power Dissipation (Device Only)		14.0		mW
Power Dissipation (Device and Ethernet components)		14.1		mW

### 4.3.4 Operational Current Consumption & Power Dissipation

Table 4.4 Operational Current Consumption & Power Dissipation (VDD33IO = VDD33A = 3.3V)

PARAMETER	MIN	TYPICAL	MAX	UNIT
<b>100BASE-TX Full Duplex (USB High-Speed)</b>				
Supply current (VDD33IO, VDD33A)		288		mA
Power Dissipation (Device Only)		951		mW
<b>10BASE-T Full Duplex (USB High-Speed)</b>				
Supply current (VDD33IO, VDD33A)		243		mA
Power Dissipation (Device Only)		802		mW
<b>10BASE-T Full Duplex (USB Full-Speed)</b>				
Supply current (VDD33IO, VDD33A)		180		mA
Power Dissipation (Device Only)		594		mW

**Note:** All values measured with maximum simultaneous traffic on the Ethernet port and all USB ports.

**Note:** Magnetic power consumption:

- 100BASE-TX: ~42mA
- 10BASE-T: ~104mA

## 4.4 DC Specifications

**Table 4.5 I/O Buffer Characteristics**

PARAMETER	SYMBOL	MIN	TYP	MAX	UNITS	NOTES
IS Type Input Buffer						
Low Input Level	$V_{ILI}$	-0.3			V	
High Input Level	$V_{IHI}$			3.6	V	
Negative-Going Threshold	$V_{ILT}$	1.01	1.18	1.35	V	Schmitt trigger
Positive-Going Threshold	$V_{IHT}$	1.39	1.6	1.8	V	Schmitt trigger
SchmittTrigger Hysteresis ( $V_{IHT} - V_{ILT}$ )	$V_{HYS}$	345	420	485	mV	
Input Leakage ( $V_{IN} = VSS$ or $VDD33IO$ )	$I_{IH}$	-10		10	uA	Note 4.6
Input Capacitance	$C_{IN}$			2.5	pF	
IS_5V Type Input Buffer						
Low Input Level	$V_{ILI}$	-0.3			V	
High Input Level	$V_{IHI}$			5.5	V	
Negative-Going Threshold	$V_{ILT}$	1.01	1.18	1.35	V	Schmitt trigger
Positive-Going Threshold	$V_{IHT}$	1.39	1.6	1.8	V	Schmitt trigger
SchmittTrigger Hysteresis ( $V_{IHT} - V_{ILT}$ )	$V_{HYS}$	345	420	485	mV	
Input Leakage ( $V_{IN} = VSS$ or $VDD33IO$ )	$I_{IH}$	-10		10	uA	Note 4.6
Input Leakage ( $V_{IN} = 5.5V$ )	$I_{IH}$			120	uA	Note 4.6, Note 4.7
Input Capacitance	$C_{IN}$			3.5	pF	
O8 Type Buffers						
Low Output Level	$V_{OL}$			0.4	V	$I_{OL} = 8mA$
High Output Level	$V_{OH}$	$VDD33IO - 0.4$			V	$I_{OH} = -8mA$
OD8 Type Buffer						
Low Output Level	$V_{OL}$			0.4	V	$I_{OL} = 8mA$
O12 Type Buffers						
Low Output Level	$V_{OL}$			0.4	V	$I_{OL} = 12mA$
High Output Level	$V_{OH}$	$VDD33IO - 0.4$			V	$I_{OH} = -12mA$
OD12 Type Buffer						
Low Output Level	$V_{OL}$			0.4	V	$I_{OL} = 12mA$
ICLK Type Buffer (XI Input)						
Low Input Level	$V_{ILI}$	-0.3		0.5	V	Note 4.8
High Input Level	$V_{IHI}$	1.4		3.6	V	

**Datasheet**

**Note 4.6** This specification applies to all inputs and tri-stated bi-directional pins. Internal pull-down and pull-up resistors add +/- 50uA per-pin (typical).

**Note 4.7** This is the total 5.5V input leakage for the entire device.

**Note 4.8** XI can optionally be driven from a 25MHz single-ended clock oscillator.

**Table 4.6 100BASE-TX Transceiver Characteristics**

PARAMETER	SYMBOL	MIN	TYP	MAX	UNITS	NOTES
Peak Differential Output Voltage High	$V_{PPH}$	950	-	1050	mVpk	Note 4.9
Peak Differential Output Voltage Low	$V_{PPL}$	-950	-	-1050	mVpk	Note 4.9
Signal Amplitude Symmetry	$V_{SS}$	98	-	102	%	Note 4.9
Signal Rise and Fall Time	$T_{RF}$	3.0	-	5.0	nS	Note 4.9
Rise and Fall Symmetry	$T_{RFS}$	-	-	0.5	nS	Note 4.9
Duty Cycle Distortion	$D_{CD}$	35	50	65	%	Note 4.10
Overshoot and Undershoot	$V_{OS}$	-	-	5	%	
Jitter				1.4	nS	Note 4.11

**Note 4.9** Measured at line side of transformer, line replaced by 100 $\Omega$  (+/- 1%) resistor.

**Note 4.10** Offset from 16nS pulse width at 50% of pulse peak.

**Note 4.11** Measured differentially.

**Table 4.7 10BASE-T Transceiver Characteristics**

PARAMETER	SYMBOL	MIN	TYP	MAX	UNITS	NOTES
Transmitter Peak Differential Output Voltage	$V_{OUT}$	2.2	2.5	2.8	V	Note 4.12
Receiver Differential Squelch Threshold	$V_{DS}$	300	420	585	mV	

**Note 4.12** Min/max voltages guaranteed as measured with 100 $\Omega$  resistive load.

## 4.5 AC Specifications

This section details the various AC timing specifications of the LAN9514/LAN9514i.

**Note:** The USBDP and USBDM pin timing adheres to the USB 2.0 specification. Refer to the Universal Serial Bus Revision 2.0 specification for detailed USB timing information.

### 4.5.1 Equivalent Test Load

Output timing specifications assume the 25pF equivalent test load illustrated in [Figure 4.1](#) below.

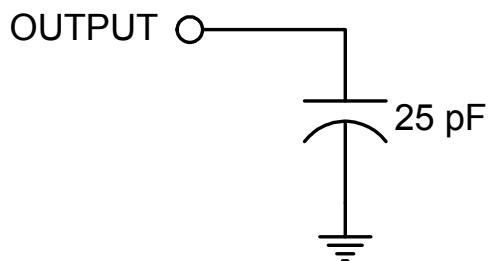

**Figure 4.1 Output Equivalent Test Load**

### 4.5.2 Reset Timing

The nRESET pin input assertion time must be a minimum of 1  $\mu$ S. Assertion of nRESET is not a requirement. However, if used, it must be asserted for the minimum period specified.

### 4.5.3 EEPROM Timing

The following specifies the EEPROM timing requirements for LAN9514/LAN9514i:

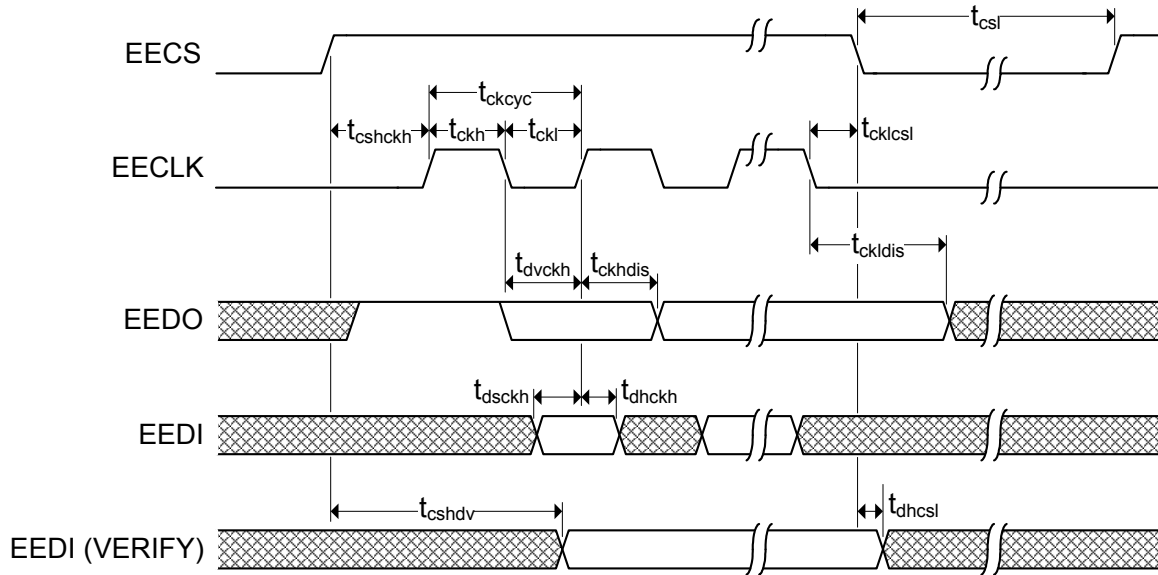

Figure 4.2 EEPROM Timing

Table 4.8 EEPROM Timing Values

SYMBOL	DESCRIPTION	MIN	TYP	MAX	UNITS
$t_{ckcyc}$	EECLK Cycle time	1110		1130	ns
$t_{ckh}$	EECLK High time	550		570	ns
$t_{ckl}$	EECLK Low time	550		570	ns
$t_{cshckh}$	EECS high before rising edge of EECLK	1070			ns
$t_{cklcsl}$	EECLK falling edge to EECS low	30			ns
$t_{dvckh}$	EEDO valid before rising edge of EECLK	550			ns
$t_{ckhdis}$	EEDO disable after rising edge EECLK	550			ns
$t_{dsckh}$	EEDI setup to rising edge of EECLK	90			ns
$t_{dhckh}$	EEDI hold after rising edge of EECLK	0			ns
$t_{ckldis}$	EECLK low to data disable (OUTPUT)	580			ns
$t_{cshdv}$	EEDO valid after EECS high (VERIFY)			600	ns
$t_{dhcsl}$	EEDO hold after EECS low (VERIFY)	0			ns
$t_{csl}$	EECS low	1070			ns

#### 4.5.4 JTAG Timing

This section specifies the JTAG timing of the device.

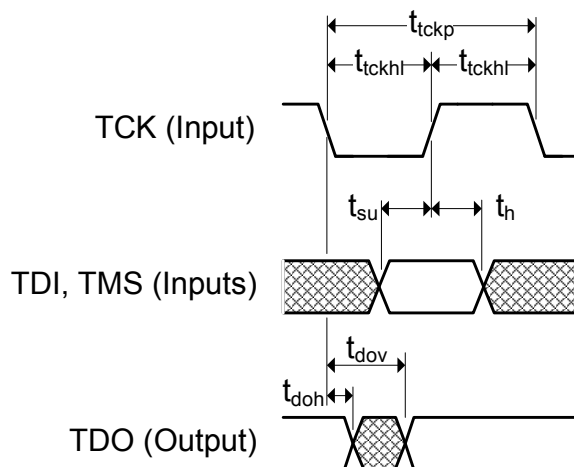

Figure 4.3 JTAG Timing

Table 4.9 JTAG Timing Values

SYMBOL	DESCRIPTION	MIN	MAX	UNITS	NOTES
$t_{tckp}$	TCK clock period	66.67		ns	
$t_{tckhl}$	TCK clock high/low time	$t_{tckp} * 0.4$	$t_{tckp} * 0.6$	ns	
$t_{su}$	TDI, TMS setup to TCK rising edge	10		ns	
$t_h$	TDI, TMS hold from TCK rising edge	10		ns	
$t_{dov}$	TDO output valid from TCK falling edge		16	ns	
$t_{doh}$	TDO output hold from TCK falling edge	0		ns	



## 4.6 Clock Circuit

LAN9514/LAN9514i can accept either a 25MHz crystal (preferred) or a 25MHz single-ended clock oscillator (+/- 50ppm) input. If the single-ended clock oscillator method is implemented, XO should be left unconnected and XI should be driven with a nominal 0-3.3V clock signal. The input clock duty cycle is 40% minimum, 50% typical and 60% maximum.

It is recommended that a crystal utilizing matching parallel load capacitors be used for the crystal input/output signals (XI/XO). See [Table 4.10](#) for the recommended crystal specifications.

**Table 4.10 LAN9514/LAN9514i Crystal Specifications**

PARAMETER	SYMBOL	MIN	NOM	MAX	UNITS	NOTES
Crystal Cut	AT, typ					
Crystal Oscillation Mode	Fundamental Mode					
Crystal Calibration Mode	Parallel Resonant Mode					
Frequency	$F_{fund}$	-	25.000	-	MHz	
Frequency Tolerance @ 25°C	$F_{tol}$	-	-	+/-50	PPM	<a href="#">Note 4.13</a>
Frequency Stability Over Temp	$F_{temp}$	-	-	+/-50	PPM	<a href="#">Note 4.13</a>
Frequency Deviation Over Time	$F_{age}$	-	+/-3 to 5	-	PPM	<a href="#">Note 4.14</a>
Total Allowable PPM Budget		-	-	+/-50	PPM	<a href="#">Note 4.15</a>
Shunt Capacitance	$C_O$	-	7 typ	-	pF	
Load Capacitance	$C_L$	-	20 typ	-	pF	
Drive Level	$P_W$	300	-	-	uW	
Equivalent Series Resistance	$R_1$	-	-	50	Ohm	
Operating Temperature Range		<a href="#">Note 4.16</a>	-	<a href="#">Note 4.17</a>	°C	
LAN9514/LAN9514i XI Pin Capacitance		-	3 typ	-	pF	<a href="#">Note 4.18</a>
LAN9514/LAN9514i XO Pin Capacitance		-	3 typ	-	pF	<a href="#">Note 4.18</a>

**Note 4.13** The maximum allowable values for Frequency Tolerance and Frequency Stability are application dependant. Since any particular application must meet the IEEE +/-50 PPM Total PPM Budget, the combination of these two values must be approximately +/-45 PPM (allowing for aging).

**Note 4.14** Frequency Deviation Over Time is also referred to as Aging.

**Note 4.15** The total deviation for the Transmitter Clock Frequency is specified by IEEE 802.3u as +/- 50 PPM.

**Note 4.16** 0°C for commercial version, -40°C for industrial version.

**Note 4.17** +70°C for commercial version, +85°C for industrial version.

**Note 4.18** This number includes the pad, the bond wire and the lead frame. PCB capacitance is not included in this value. The XO/XI pin and PCB capacitance values are required to accurately calculate the value of the two external load capacitors. These two external load capacitors determine the accuracy of the 25.000 MHz frequency.

## Chapter 5 Package Outline

### 5.1 64-QFN Package

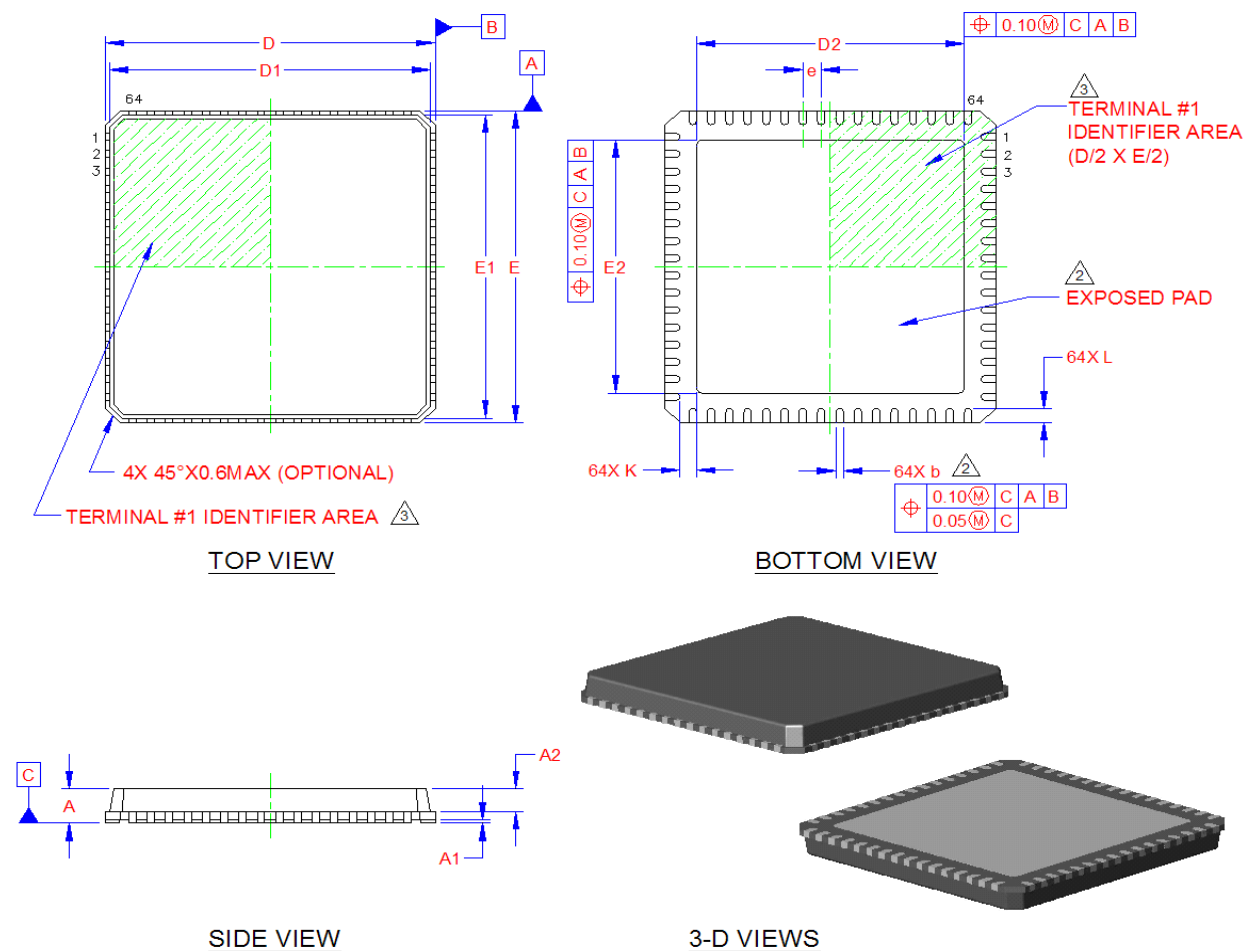

Figure 5.1 LAN9514/LAN9514i 64-QFN Package Definition

Table 5.1 LAN9514/LAN9514i 64-QFN Dimensions

	MIN	NOMINAL	MAX	REMARKS
A	0.80	0.85	1.00	Overall Package Height
A1	0.00	0.02	0.05	Standoff
A2	-	0.65	0.80	Mold Cap Thickness
D/E	8.90	9.00	9.10	X/Y Body Size
D1/E1	8.65	8.75	8.85	X/Y Mold Cap Size
D2/E2	7.20	7.30	7.40	X/Y Exposed Pad Size
L	0.30	0.40	0.50	Terminal Length
b	0.18	0.25	0.30	Terminal Width
e	0.50 BSC			Terminal Pitch
K	0.35	-	-	Pin to Center Pad Clearance

**Notes:**

1. All dimensions are in millimeters unless otherwise noted.
2. Dimension "b" applies to plated terminals and is measured between 0.15 and 0.30 mm from the terminal tip.
3. Details of terminal #1 identifier are optional, but must be located within the area indicated. The terminal #1 identifier may be either a mold or marked feature.

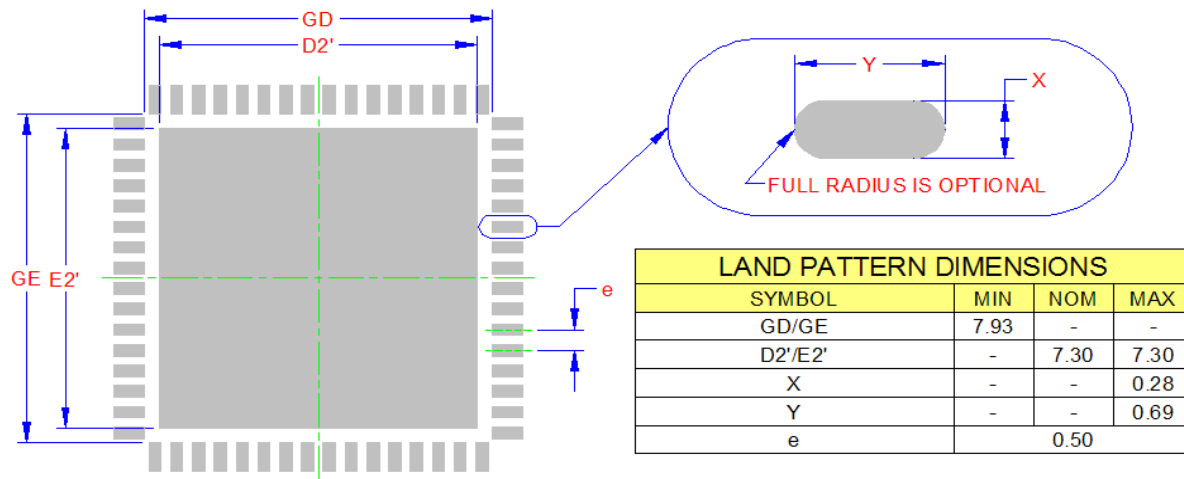

THE USER MAY MODIFY THE PCB LAND PATTERN DIMENSIONS  
BASED ON THEIR EXPERIENCE AND/OR PROCESS CAPABILITY

RECOMMENDED PCB LAND PATTERN

**Figure 5.2 LAN9514/LAN9514i Recommended PCB Land Pattern**

## Chapter 6 Datasheet Revision History

**Table 6.1 Customer Revision History**

REVISION LEVEL AND DATE	SECTION/FIGURE/ENTRY	CORRECTION
Rev. 1.2 (02-29-12)	Section 4.3, "Power Consumption," on page 42	Added suspend 0, suspend 1, and suspend 3 power consumption data.
Rev. 1.1 (09-19-11)	All	Fixed typos.
	Section 2.1, "Power Connections," on page 16	Added power connections section with diagram.
Rev. 1.1 (11-24-09)	All: Cover, Ordering Code, Operational Characteristics	Added industrial temperature range option: (-40°C to +85°C)
	Section 4.5.4, "JTAG Timing," on page 48	Added JTAG timing information
Rev. 1.0 (04-20-09)	Section 4.1, "Absolute Maximum Ratings*," on page 41 and Cover	Added ESD information.
	Chapter 3, "EEPROM Controller (EPC)," on page 21	Updated supported EEPROM information.
	Section 4.3, "Power Consumption," on page 42	Added power consumption values.
	Section 4.4, "DC Specifications," on page 44	Added input capacitance and leakage values.
	All	Fixed various typos.
Rev. 1.0 (03-03-09)	All	Initial Release

## X-ON Electronics

Largest Supplier of Electrical and Electronic Components

*Click to view similar products for [USB Interface IC](#) category:*

*Click to view products by [Microchip](#) manufacturer:*

Other Similar products are found below :

[CY7C69356-48LTXC](#) [USB3319C-GJ-TR](#) [USB3370B-EZK-TR](#) [CYPD2120-24LQXI](#) [CYPD2122-20FNXIT](#) [CYPD2122-24LQXIT](#) [LIF-UC120-SWG36ITR50](#) [UPD360-A/6HX](#) [CP2102NP1174GM](#) [DPO2039DABQ-13](#) [CY7C68034-56LTXC](#) [TUSB212RWBT](#) [TUSB213IRGYT](#) [TUSB213RGYT](#) [USB3503T-I/ML](#) [CY7C63310-SXC](#) [USB3316C-CP-TR](#) [USB3250-ABZJ](#) [MAX3107ETG+](#) [MAX14632EZK+T](#) [LAN9514-JZX](#) [CYPD2120-24LQXIT](#) [MAX3100CEE+T](#) [USB5806/KD](#) [USB5826-I/KD](#) [USB5826/KD](#) [USB5906/KD](#) [USB5916/KD](#) [USB5926/KD](#) [TUSB215QRGYTQ1](#) [NB7NPQ701MMTTBG](#) [TUSB213RGYR](#) [USB5926-I/KD](#) [USB5906-I/KD](#) [USB4640I-HZH-03](#) [CY7C63813-SXC](#) [CY7C63823-SXC](#) [CY7C64215-28PVXC](#) [CY7C68013A-128AXC](#) [CY7C68013A-56LTXC](#) [CY7C68013A-56LTXI](#) [CY7C68013A-56PVXC](#) [CY7C68013A-56PVXI](#) [CYPD1120-40LQXI](#) [AP43771VDKZ-13](#) [AP43771VFBZ-13](#) [DIO32320MP10](#) [HT42B534-2](#) [FT2232HPQ-TRAY](#) [FT312D-32L1C-T](#)