

Features

- Complete BORSCHT Functions for 2 Channels in a Single VoicePort™ Device
- Integrated Power Management
 - Integrated high voltage switching regulator controllers generates supplies for VBH, VBM & VBL
- Low power Idle and On-hook transmission states
- Worldwide Programmability
 - Input impedance, Balance Impedance, Gain
 - DC feed voltage and current limit
 - Ringing frequency, voltage and current limit
 - 12 kHz and 16 kHz Metering
 - Programmable supervision thresholds
- Ringing
 - 5 REN with pin for pin compatible 100-V (Le88266) and 120-V (Le88286) devices
 - Up to 110-Vpk internal balanced ringing with programmable DC offset
- Powerful Signal Generator
 - Universal Caller ID generation
 - Up to 4 simultaneous tones
- VoicePath™ API-II Software Available to Implement FXS Functions
 - Supports device calibration
 - Line configuration via VoicePath Profile Wizard
- VeriVoice™ Test Suite Subscriber Loop Test
 - Seamless integration with VP-API-II software
 - Utilizes integrated self test capabilities
 - Line fault detection and reporting
- Pin Selectable PCM/MPI or GCI Interface
- G.711 μ -law, A-law, or 16 bit Linear Coding
- Wideband 16 kHz Sampling Mode
- Integrated 150 mW 3-V Relay Driver
 - External catch diode required
- Small Footprint Package - Exposed Pad 64-pin QFN
- Minimal External Discrete Components Required

Document ID#: 126939

July 2014

Ordering Information

Le88266TQC	64-pin QFN (Green) ¹	Tray ²
Le88286TQC	64-pin QFN (Green) ¹	Tray ²
Le88266DLC	80-pin eLQFP (Green) ¹	Tray ²
Le88286DLC	80-pin eLQFP (Green) ¹	Tray ²

1. The green package meets RoHS Directive 2002/95/EC of the European Council to minimize the environmental impact of electrical equipment.
2. For delivery using a tape and reel packing system, add a "T" suffix to the OPN (Ordering Part Number) when placing an order.

Applications

- Voice enabled Cable EMTA's
- DSL Gateways and IAD's
- Fiber to the Building/Home (FTTB/H) Optical Network Terminals (ONT)
- Wireless Local Loop (WLL), PBX

Description

The Microsemi® Le88266/286 Automatic Battery Switching (ABS) VoicePort device implements a dual-channel telephone line interface from the high voltage subscriber line to the PCM / MPI digital interface.

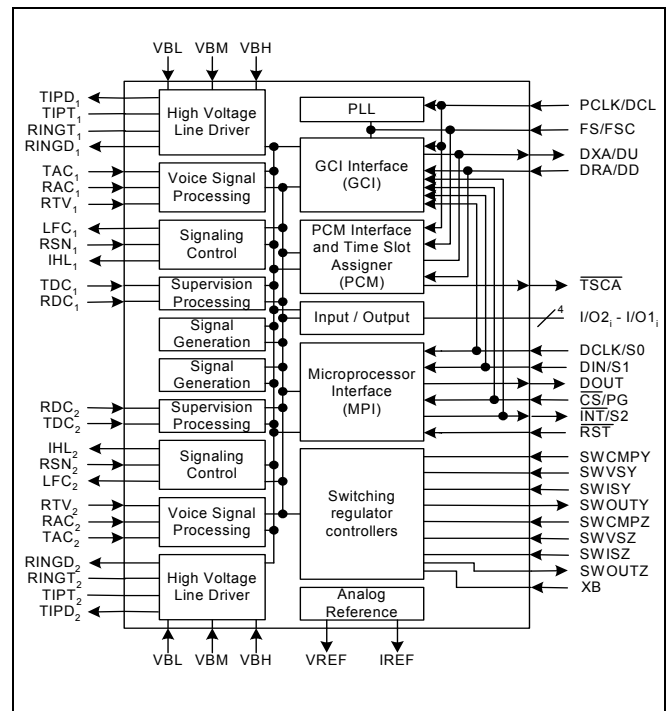

Figure 1 - VoicePort Device Block Diagram

Table of Contents

1.0 Product Description	5
2.0 Detailed Features of the Le88266/286 Device	5
3.0 Block Descriptions	6
3.1 Digital Interfaces	6
3.2 PCM/MPI Interface and Time Slot Assigner (PCM)	7
3.3 Microprocessor Interface (MPI)	9
3.4 General Circuit Interface (GCI)	11
3.5 Internal Configuration Registers	20
3.6 Input / Output Block	20
3.7 Voice Signal Processors	20
3.8 Signal Generation and Cadence Control	23
3.9 Signaling Control	26
3.10 Supervision Processing	30
3.11 Analog Reference Circuits	32
3.12 High Voltage Line Driver	32
3.13 Internal Test Termination	32
3.14 Test Load Switch (Le88286DLC only)	32
3.15 Line Testing	32
3.16 Switching Regulator Controllers	33
4.0 Connection Diagrams and Pin Descriptions	34
5.0 Absolute Maximum Ratings	40
5.1 Thermal Resistance	41
5.2 Package Assembly	41
6.0 Operating Ranges	41
6.1 Recommended Operating Conditions	41
7.0 Electrical Characteristics	42
7.1 Test Conditions	42
7.2 Supply Currents and Power Dissipation	42
7.3 DC Characteristics	43
7.4 DC Feed and Signaling	44
7.5 Test Load Switch (Le88286DLC Device Only)	44
7.6 Metering	44
7.7 Ringing	45
7.8 Switching Regulator Controller	45
7.9 Converter Configuration Signal Sense Accuracy	46
7.10 Transmission Characteristics - Narrowband Codec Mode	47
7.11 Attenuation Distortion - Narrowband Codec Mode	48
7.12 Discrimination Against Out-of-Band Input Signals - Narrowband Codec Mode	49
7.13 Discrimination Against 12- and 16-kHz Metering Signals - Narrowband Codec Mode	49
7.14 Spurious Out-of-Band Signals at the Analog Output - Narrowband Codec Mode	50
7.15 Overload Compression - Narrowband Codec Mode	50
7.16 Gain Linearity - Narrowband Codec Mode	51
7.17 Total Distortion Including Quantizing Distortion - Narrowband Codec Mode	52
7.18 Group Delay Distortion - Narrowband Codec Mode	53
7.19 Transmission Characteristics - Wideband Codec Mode	54
7.20 Attenuation Distortion - Wideband Codec Mode	55
7.21 Group Delay Distortion - Wideband Codec Mode	56
8.0 Switching Characteristics and Waveforms	57
8.1 Microprocessor Interface Timing	57
8.2 PCM Interface Timing	59
8.3 GCI Timing	62
8.4 Switcher Output Timing	65
9.0 Applications	66
9.1 Application Circuit	66
9.2 Le88266/286 VoicePort™ Device Parts List	68
10.0 Command Description and Formats	69
10.1 Command Field Summary	69
10.2 MPI Description	69
10.3 Summary of Commands	70
10.4 Detailed Descriptions Of Commands	72

Table of Contents

02h Software Reset	72
04h Hardware Reset	72
06h No Operation	72
40/41h Write/Read Transmit Time Slot	72
42/43h Write/Read Receive Time Slot	73
44/45h Write/Read Transmit and Receive Clock Slot and Transmit Clock Edge	73
46/47h Write/Read Device Configuration Register	73
4A/4Bh Write/Read Channel Enable and Operating Mode Register	74
4D/4Fh Read Signaling Register	75
50/51h Write/Read Voice Path Gains	77
52/53h Write/Read Input/Output Data Register	77
54/55h Write/Read Input/Output Direction Register	78
56/57h Write/Read System State	78
5E/5Fh Write/Read Device Mode Register	79
60/61h Write/Read Operating Functions	80
68/69h Write/Read System State Configuration	81
6C/6Dh Write/Read Interrupt Mask Register	82
70/71h Write/Read Operating Conditions	82
73h Read Revision and Product Code Number (RCN,PCN)	83
80/81h Write/Read GX Filter Coefficients	83
82/83h Write/Read GR Filter Coefficients	83
86/87h Write/Read B Filter FIR Coefficients	84
88/89h Write/Read X Filter Coefficients	85
8A/8Bh Write/Read R Filter Coefficients	86
96/97h Write/Read B Filter IIR Coefficients	87
98/99h Write/Read Z Filter FIR Coefficients	87
9A/9Bh Write/Read Z Filter IIR Coefficients	87
A6/A7h Write/Read Converter Configuration	88
C2/C3h Write/Read Loop Supervision Parameters	90
C6/C7h Write/Read DC Feed Parameters	90
CA/CBh Write/Read Digital Impedance Scaling Network (DISN)	91
CDh Read Transmit PCM/Test Data	91
CFh Read Test Data Buffer	92
D0/D1h Write/Read Metering Parameters	93
D2/D3h Write/Read Signal Generator A, B and Bias Parameters.	94
D4/D5h Write/Read Signal Generator C and D Parameters.	96
DE/DFh Write/Read Signal Generator Control	97
E0/E1h Write/Read Cadence Timer	98
E2/E3h Write/Read Caller Identification Number Data	98
E4/E5h Write/Read Switching Regulator Parameters	99
E6/E7h Write/Read Switching Regulator Control	100
E8/E9h Write/Read Battery Calibration Register	101
EA/EBh Write/Read Caller Identification Number Parameters	102
EC/EDh Write/Read Internal Configuration Register 1	103
EE/EFh Write/Read Internal Configuration Register 2	103
F2/F3h Write/Read Internal Configuration Register 3	103
F4/F5h Write/Read Internal Configuration Register 4	103
FA/FBh Write/Read Internal Configuration Register 5	103
FC/FDh Write/Read DC Calibration Register	104
11.0 Physical Dimensions	106
11.1 Detailed Bottom View of 80-Pin eLQFP	108
12.0 Recommended Land Patterns	109
13.0 Related Collateral	111
13.1 Documentation	111
13.2 Development Hardware	111
13.3 Development Software	111
14.0 Revision History	112

List of Figures

Figure 1 - VoicePort Device Block Diagram	1
Figure 2 - Le88266/286 VoicePort™ Block Diagram	6
Figure 3 - PCM highway structure	7
Figure 4 - Transmit PCM interface	8
Figure 5 - Receive PCM Interface	8
Figure 6 - PCM Interface Timing for XE = 0 (Transmit Data On Negative PCLK Edge)	9
Figure 7 - Microprocessor Interface Timing	10
Figure 8 - Multiplexed GCI Time Slot Structure	12
Figure 9 - GCI Interface and Packet Time Slot Selection	13
Figure 10 - Security Procedure For C Downstream Byte	14
Figure 11 - Maximum Speed Monitor Handshake Timing	16
Figure 12 - Monitor Transmitter Mode Diagram	16
Figure 13 - Monitor Receiver Mode Diagram	17
Figure 14 - Voice Signal Processing Block Diagram	21
Figure 15 - Signal Generator	24
Figure 16 - Active State DC Feed I / V Characteristic	28
Figure 17 - Metering Pulse Definitions	29
Figure 18 - Balanced Ringing with Fixed Tracking Supply	30
Figure 19 - Le88266/286 Device 64-Pin QFN Package (Top View)	34
Figure 20 - Le88266 Device 80-Pin eLQFP Package (Top View)	35
Figure 21 - Le88286 Device 80-Pin eLQFP Package (Top View)	36
Figure 22 - Transmit Path Attenuation vs. Frequency	48
Figure 23 - Receive Path Attenuation vs. Frequency	48
Figure 24 - Discrimination Against Out-of-Band Signals	49
Figure 25 - Spurious Out-of-Band Signals	50
Figure 26 - Analog-to-Analog Overload Compression	51
Figure 27 - A-law Gain Linearity with Tone Input (Both Paths)	51
Figure 28 - μ -law Gain Linearity with Tone Input (Both Paths)	52
Figure 29 - Total Distortion with Tone Input (Both Paths)	52
Figure 30 - Group Delay Distortion	53
Figure 31 - Transmit Path Attenuation vs. Frequency	55
Figure 32 - Receive Path Attenuation vs. Frequency	55
Figure 33 - Group Delay Distortion	56
Figure 34 - Microprocessor Interface (Input Mode)	58
Figure 35 - Microprocessor Interface (Output Mode)	58
Figure 36 - PCM Highway Timing for XE = 0 (Transmit on Negative PCLK Edge)	60
Figure 37 - PCM Highway Timing for XE = 1 (Transmit on Positive PCLK Edge)	61
Figure 38 - PCM Clock Timing	61
Figure 39 - Input and Output Waveforms for AC Tests	61
Figure 40 - 4.096 MHz DCL Operation	63
Figure 41 - 2.048 MHz DCL Operation	64
Figure 42 - Switcher Output Waveform SWOUTY, SWOUTZ	65
Figure 43 - Le88266/286 device Application Circuit	66
Figure 44 - Le88266/286 Switching Regulator Circuit	67
Figure 45 - 64-Pin QFN	106
Figure 46 - 80-Pin eLQFP	107
Figure 47 - 64-Pin QFN	109
Figure 48 - 80-Pin eLQFP	110

1.0 Product Description

The Le88266/286 device implements a dual-channel universal telephone line interface. This enables the addition of a dual, low cost, high performance, software programmable line interface to cable EMTA's, fiber ONTs, Integrated Access Devices, DSL modems, SMTA's or set top boxes for multiple country applications worldwide. The Le88266/286 device performs all necessary voice telephony functions from driving a high voltage subscriber telephone line to DSP codec functions for two lines. All AC, DC, and signaling parameters are fully programmable via microprocessor interfaces. The Le88266/286 device has integrated high voltage switching regulator controllers which can generate the high voltages needed for efficiently powering and ringing analog telephones. The high performance architecture permits high efficiency in all operating states and corresponding low power dissipation. Additionally, the Le88266/286 has self-test and line-test support to allow the system to resolve faults to the line or line circuit. The integrated digital access to important line information such as AC and DC line voltage on Tip or Ring and Metallic or Longitudinal currents is crucial for remote applications where dedicated test hardware is not cost effective.

The dual-channel Le88266/286 device is a highly functional voice-over-broadband system that meets the needs of short and medium loop customers. The Le88266/286 devices are targeted toward voice applications and provide all BORSCHT functions. The Le88266 device has up to 92-Vpk internal ringing capability that has been optimized for short loop applications. The Le88286DLC device has 110-Vpk internal ringing capability that has been optimized for short loop and medium loop applications, can operate in a balanced or unbalanced ringing mode, and offers an integrated test load switch to control an external load.

The Le88266/286 device selectively interfaces with a PCM or GCI backplane and can be controlled over the MPI or GCI interface.

The software programmed transmission filter coefficients and supervision data are easily calculated with the WinSLAC™ software, which allows the designer to enter a description of system requirements. WinSLAC then returns the necessary data and plots the predicted system results. This data is then processed by the Profile Wizard and compiled into the VoicePath™ API-II software to allow easy integration with system software and quickly enable implementation of the required product features.

2.0 Detailed Features of the Le88266/286 Device

The Le88266/286 device supports the following features:

- Single chip solution provides high voltage line driving, digital signal processing, and high voltage power generation for two or more lines
- Wideband 7 kHz and narrowband 3.4 kHz codec modes
- Exceeds GR-909 transmission requirements
- Single hardware design meets worldwide requirements through software programming of:
 - Ringing waveform, frequency and amplitude
 - DC loop-feed characteristics and current-limit
 - Loop-supervision detection thresholds
 - Off-hook debounce circuit
 - Ground-key and ring-trip filters
 - Two-wire AC impedance
 - Transhybrid balance impedance
 - Transmit and receive gains
 - Transmit and receive equalization
 - Digital I/O pins
 - A-law/ μ -law and linear coding selection
 - Switching Power Supply
- Supports both loop-start and ground-start signaling
- On-hook transmission
- Power/service denial mode
- Smooth polarity reversal
- Supports wink function
- Neon lamp driving capability
- Metering generation with envelope shaping
 - Programmable metering duration
- Self-contained ringing generation and control
 - Programmable Ringing Cadencing
 - Internal battery-backed balanced or unbalanced, sine or trapezoidal ringing
 - Integrated ring-trip filter and software enabled manual or automatic ring-trip mode
- Flexible tone generation
 - Call progress tone generation
 - DTMF tone generation
 - Universal Caller ID generation
 - Howler tone generation with VP-API-II
- Only 3.3 V logic and single battery supply needed
- Integrated switching regulator controller
 - Can generate the battery voltages for each line
 - Line-feed characteristics independent of battery voltage
- MPI, PCM or GCI interfaces
 - Supports most required PCM clock frequencies from 1.024MHz to 8.192 MHz
- Compatible with inexpensive protection networks
- Monitors two-wire interface voltages and currents for subscriber line diagnostics implemented by VeriVoice Test Suite software
- Built-in voice-path test modes
- Integrated self-test features
- Internal Test Termination
- Internal 3-V relay driver (Catch diode required)
- –40°C to 85°C operation

3.0 Block Descriptions

The Le88266/286 device provides a complete software-configurable solution to BORSCHT functions from digital interface to Tip and Ring for two channels.

The device comprises a CMOS device that includes a PLL to generate the necessary clocks for the internal processing functions, digital interfaces implemented in the PCM, MPI and GCI blocks, digital I/O, analog references, switching regulator controllers, voice signal processors, supervision, signalling and signal generation blocks as well as high voltage line drivers.

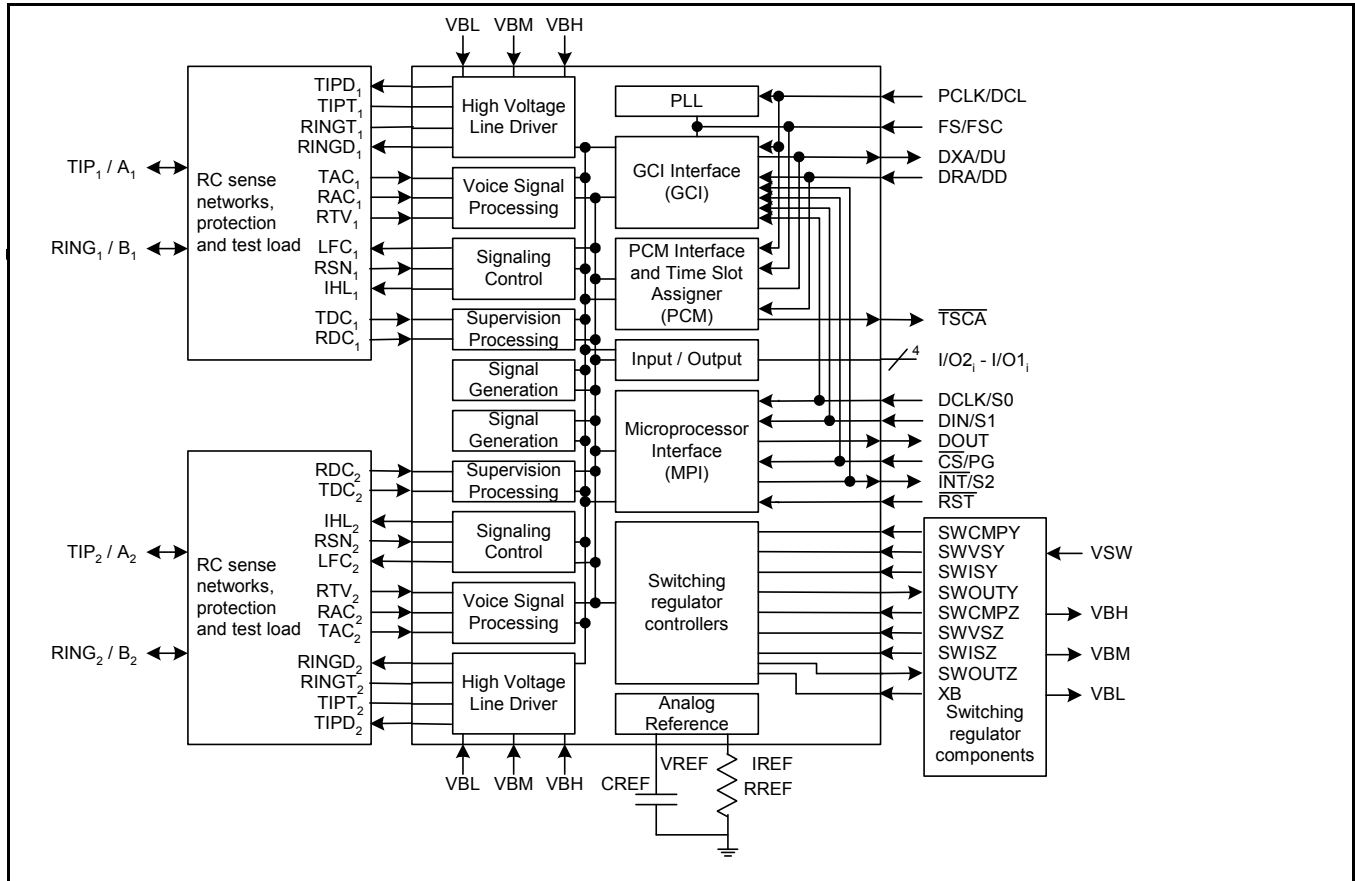

Figure 2 - Le88266/286 VoicePort™ Block Diagram

3.1 Digital Interfaces

The Le88266/286 device offers two digital interface options. The first is PCM/MPI mode, in which separate serial control and voice data interfaces are provided. Voice data is interfaced via a PCM highway with time slot assignment capability, and control information is communicated over the Micro-Processor Interface (MPI). The second is GCI mode, in which a single serial interface supports both voice data and control. Wideband mode is only available in PCM/MPI mode.

The two modes are mutually exclusive and have different advantages and disadvantages. The PCM/MPI mode is most flexible and allows a wide range of DCLK (MPI data clock) and PCLK (PCM data clock) frequencies. PCM/MPI mode also allows use of the INT interrupt pin to signal pending interrupts to the external controller. GCI mode offers the advantage of using only four signals (FSC, DCL, DU, DD) to carry voice and control data. PCM/MPI mode uses twice as many signals (FS, PCLK, DXA, DRA for voice data and CSL, DCLK, DIN, DOUT for control data) to carry the same information. GCI mode has several disadvantages, however: only 2.048 MHz and 4.096 MHz DCL frequencies are allowed; the control interface is slow (250 μS/byte maximum throughput); and interrupt handling is more complex due to the lack of an interrupt pin. Multifunction pins are implemented to support these different modes while keeping the pin count low.

3.1.1 PCM and GCI Mode Selection

The Le88266/286 device enters PCM/MPI or GCI modes based on the conditions outlined in [Table 1](#).

The PCM / GCI select pin (\overline{CS}/PG) is used in combination with the DCLK pin to determine which mode the device is in on power up. If PG is held Low and DCLK is held static, GCI mode is entered 1 ms after power up or hardware reset and the application of valid GCI DCLK and FSC signals. GCI mode will be exited at any time if PG is pulled high or a clock is detected on DCLK.

If PG is High then PCM/MPI mode is entered following power up. At this point, the mode can be changed to GCI if the GCI conditions are met. However, once a command is sent over the MPI interface, GCI mode cannot be entered without resetting the device.

From Mode	To Mode	Requirement
Power On or Hardware Reset	PCM	$\overline{CS}/PG = 1$ or DCLK has ac clock present
Power On or Hardware Reset	GCI	$\overline{CS}/PG = 0$ and DCLK does not have ac clock present
GCI	PCM	$\overline{CS}/PG = 1$ or DCLK has clock present
PCM	GCI	No commands yet sent in PCM state and $\overline{CS}/PG = 0$ (for more than 2 FS) and DCLK does not have clock present

Table 1 - PCM/GCI Mode Selection

These methods are used to ensure the device operates in the desired mode at all times.

3.2 PCM/MPI Interface and Time Slot Assigner (PCM)

This is a synchronized serial mode of communication between the system and the Le88266/286 device. In PCM mode, data can be transmitted/received on a serial PCM highway. This highway uses FS and PCLK as reference.

Data is transmitted out of the DXA pin and received on the DRA pin. The Le88266/286 device transmits/receives single 8-bit time slot (A-law/ μ -law) compressed voice data or 16-bit two's complement linear voice data, occupying two conventional time slots. The PCLK is a data clock supplied to the device that determines the rate at which the data is shifted in/out of the PCM ports. The Frame Sync (FS) pulse identifies the beginning of a transmit/receive frame and all time slots are referenced to it. For the Le88266/286 device, the frequency of the FS signal is 8 kHz. In wideband mode, two evenly spaced sets of time slots are exchanged in each frame. The user programs the first time slot and the second one is generated automatically and placed 125/2 μ sec from the first time slot (the frame is assumed to have an even number of time slots). The PCLK frequency can be a number of fixed frequencies as defined by command [46/47h Write/Read Device Configuration Register, on page 73](#). For each channel, voice data compression and type of coding is selected by the C/L (Compressed/Linear) and A/ μ -law bits in command [60/61h Write/Read Operating Functions, on page 80](#). The wideband mode is selected with the WBAND bit in command [4A/4Bh Write/Read Channel Enable and Operating Mode Register, on page 74](#) and it affects both channels of the device.

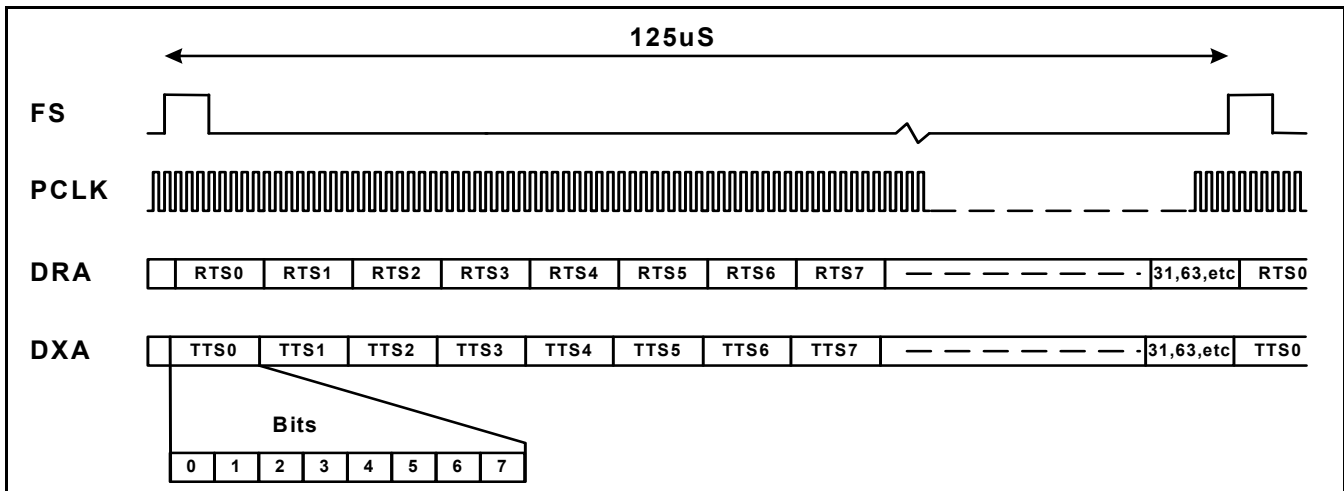

Figure 3 - PCM highway structure

The Le88266/286 device command [44/45h Write/Read Transmit and Receive Clock Slot and Transmit Clock Edge](#), on page 73 allows the time slots to be offset to eliminate any clock skew in the system. The Transmit Clock Slot and Receive Clock Slot fields are each three bits wide to offset the time slot assignment by 0 to 7 PCLK periods. The Transmit and Receive Clock Slot is a global command that is applied at the device level. Thus, for each channel, two time slots must be assigned — one for transmitting voice data and the other for receiving voice data. Figure 2 shows the PCM highway time slot structure.

3.2.1 Transmit PCM Interface

The Transmit PCM interface receives a code from the voice signal processor (compressor), which may be either 8 bit compressed code (A-law/ μ -law) or a 16-bit two's complement linear code. The transmit PCM interface logic ([Figure 4](#)) controls the transmission of the data onto the PCM highway through the output port selection circuitry and the time and clock slot control block. The time slot control signal (\overline{TSCA}) is low whenever PCM data is transmitted on the DXA pin. This signal can be used for arbitration when there are multiple Le88266/286 devices on the PCM bus. The data can be transmitted on either edge of the PCLK. The clock edge on which the data is transmitted is selected by the XE bit in the Transmit and Receive Clock Slot Register (Command 44h/45h).

Command [40/41h Write/Read Transmit Time Slot](#), on page 72 allows the time slot of the selected channel to be programmed. The Transmit Time Slot Register allows up to 128 8-bit time slots (using a PCLK of 8.192 MHz) in each frame. The PCLK frequency can be a number of fixed frequencies as defined by command [46/47h Write/Read Device Configuration Register](#), on page 73; this means that for compressed data the number of 8-bit time slots can vary between 24 and 128, while linear mode supports between 12 and 64 pairs of time slots. In wideband mode, the user must only program time slots in the lower half of the range. Note that linear mode requires two back-to-back time slots to transmit one voice channel. The data is transmitted in bytes with the most significant bit first. [Figure 6](#) illustrates data flow on the PCM highway.

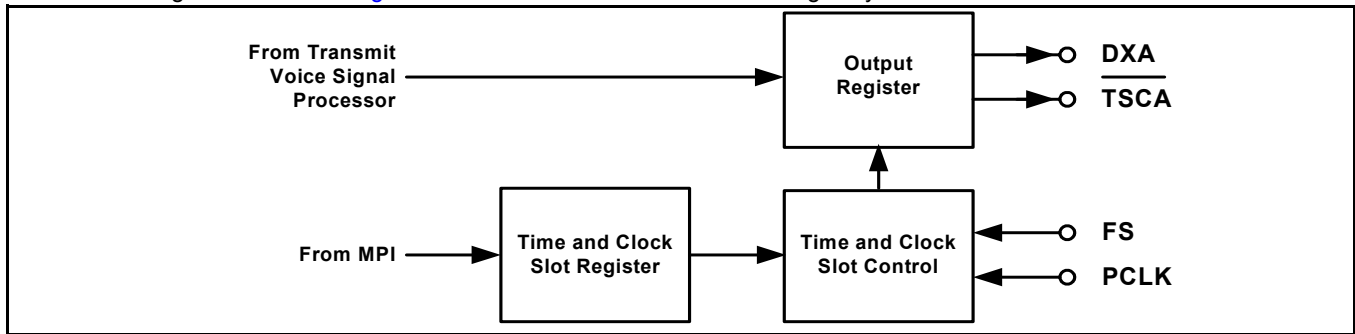

Figure 4 - Transmit PCM interface

3.2.2 Receive PCM Interface

The receive PCM interface logic ([Figure 4](#)) controls the reception of data bytes from the PCM highway. 8-bit compressed (A-law/ μ -law) or 16-bit two's complement linear data is formatted and passed to the voice signal processor (expander).

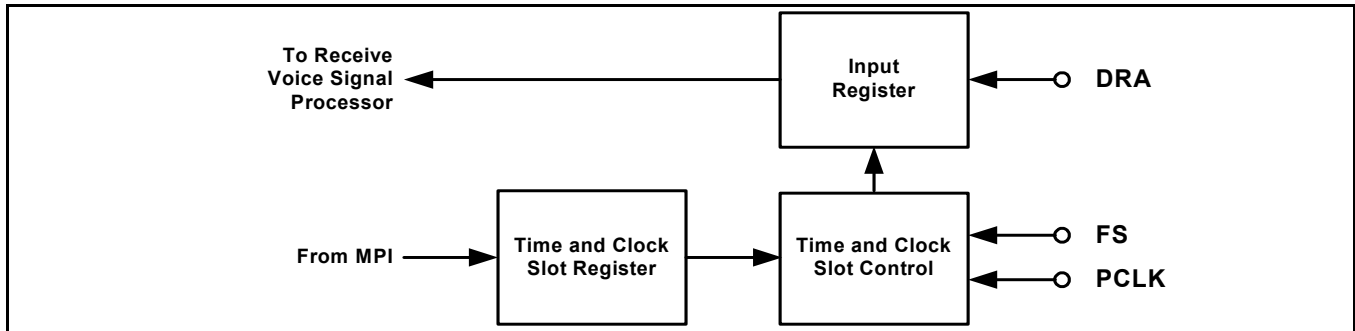

Figure 5 - Receive PCM Interface

Command [42/43h Write/Read Receive Time Slot](#), on page 73 allows the time slot of the selected channel to be programmed. The Receive Time Slot Register is 7 bits wide and allows up to 128 8-bit time slots (using a PCLK of 8.192 MHz) in each frame. The PCLK frequency can be a number of fixed frequencies as defined by command [46/47h Write/Read Device Configuration Register](#), on page 73; this means that for compressed data the number of 8-bit time slots can vary between 24 and 128, while linear mode

supports between 12 and 64 pairs of time slots. In wideband mode, the user must only program time slots in the lower half of the range. Note that linear mode requires two back-to-back time slots to transmit/receive one voice channel. The data is transmitted/received in bytes with the most significant bit first. [Figure 6](#) illustrates data flow on the PCM highway.

3.2.3 Signaling on the PCM Highway

Signaling information can be sent on the PCM output if A- or μ -Law companding is selected and the SMODE bit in command [46/47h Write/Read Device Configuration Register, on page 73](#) is set. In this case an extra time slot of signaling data is transmitted every frame immediately after the PCM voice data for the channel (see [Figure 6](#)) and is transmitted whether or not the voice channel is active. The signaling data is defined in [Table 2](#).

	S7	S6	S5	S4	S3	S2	S1	S0
Channel 1	CFAIL	OCALMY ₁	TEMPA ₁	IO2 ₁	CAD ₁	CID ₁	GNK ₁	HOOK ₁
Channel 2	DAT	OCALMZ ₂	TEMPA ₂	IO2 ₂	CAD ₂	CID ₂	GNK ₂	HOOK ₂

Table 2 - PCM Highway Real Time Signaling Data Definition

Default settings, of consecutive time slots for Channel 2, cannot be used with PCM signaling. Also, the monitor A-->D converter output on the PCM highway is in linear mode which conflicts with PCM signaling.

Masking or unmasking of the interrupts in the interrupt mask register does not affect the real time signaling data. See command [4D/4Fh Read Signaling Register, on page 75](#) for bit definitions

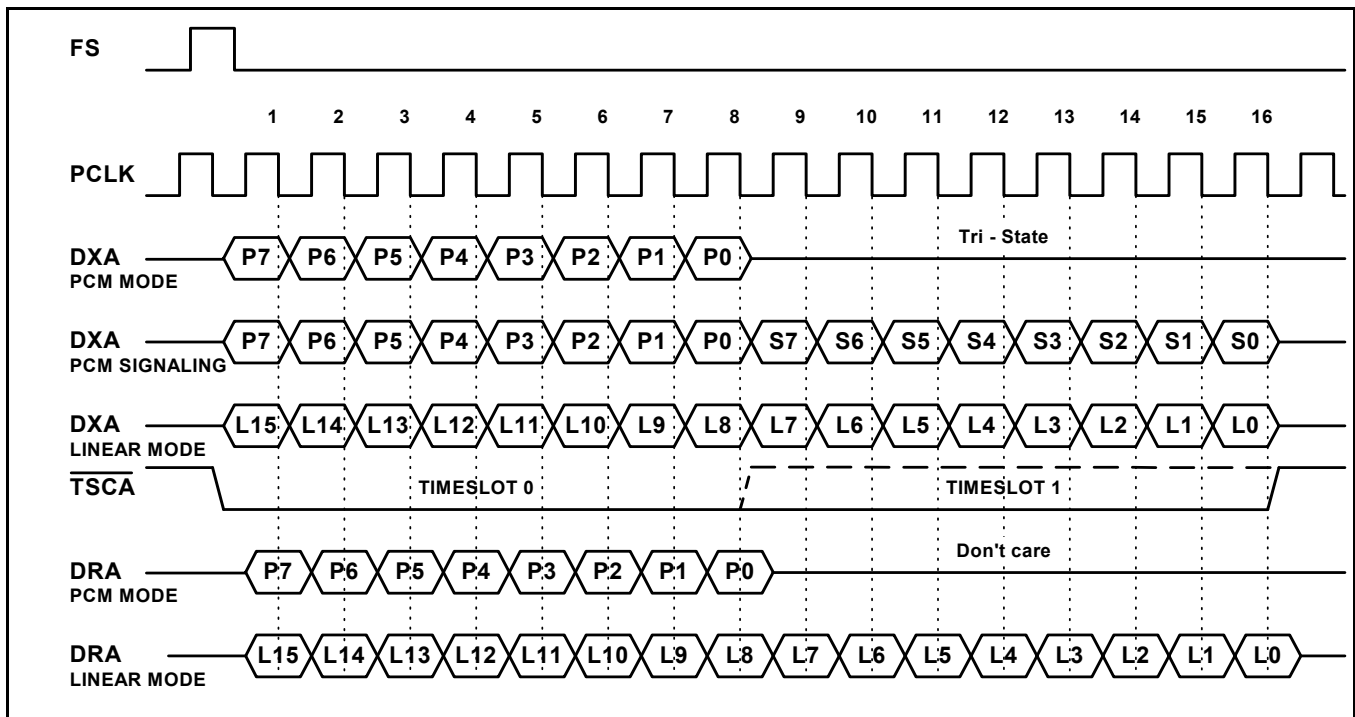

Figure 6 - PCM Interface Timing for XE = 0 (Transmit Data On Negative PCLK Edge)

3.3 MICROPROCESSOR INTERFACE (MPI)

The microprocessor interface (MPI) block communicates with the external host microprocessor over a serial interface. It passes user control information to the other blocks, and it passes status information back to the external host.

The MPI physically consists of a serial data input (DIN) serial data output (DOUT), a data clock (DCLK), a chip select (\overline{CS}) and an interrupt signal (INT) (see [Figure 7, Microprocessor Interface Timing, on page 10](#)). The serial input consists of 8-bit commands that can be followed with additional bytes of input data, or can be followed by the Le88266/286 device sending out bytes of data. All data input and output is MSB (D7) first and LSB (D0) last. All data bytes are read or written one at a time, with \overline{CS} going High

for at least a minimum off period (see [Microprocessor Interface Timing, on page 57](#)) before the next byte is read or written. Only a single channel should be enabled during read commands.

All commands that require additional input data to the device must have the input data as the next N words written into the device (for example, framed by the next N transitions of \overline{CS}). All unused bits must be programmed to 0 to ensure compatibility with future parts. All commands that are followed by output data will cause the device to output data for the next N transitions of \overline{CS} going Low. The Le88266/286 device will not accept any commands until all the data has been shifted out. The output values of unused bits are not specified. Note that the Voice Channel Enable bits, EC1, EC2 in command [4A/4Bh Write/Read Channel Enable and Operating Mode Register, on page 74](#) are used to control access to voice channel specific registers within the device.

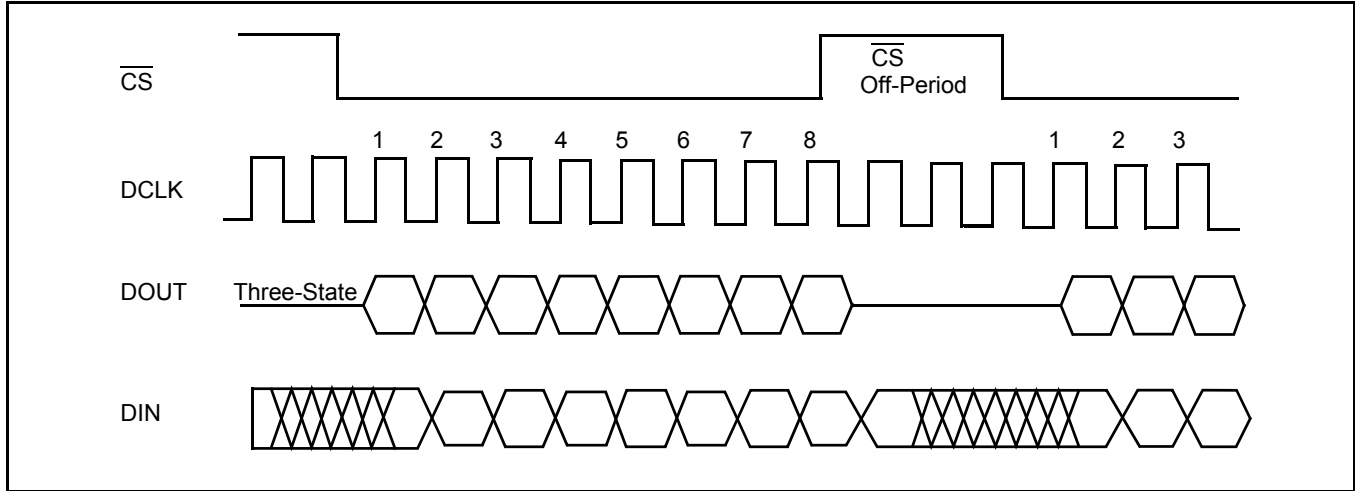

Figure 7 - Microprocessor Interface Timing

An MPI cycle is defined by transitions of \overline{CS} and DCLK. If the \overline{CS} lines are held in the High state between accesses, the DCLK may run continuously with no change to the internal control data. Using this method, the same DCLK can be run to a number of Le88266/286 devices and the individual \overline{CS} lines will select the appropriate device to access. Between command sequences, DCLK can stay in the High state indefinitely with no loss of internal control information regardless of any transitions on the \overline{CS} lines. Between bytes of a multi byte read or write command sequence, DCLK can also stay in the High state indefinitely. DCLK can stay in the Low state indefinitely with no loss of internal control information, provided the \overline{CS} line remains at a High level. If the system controller has a single bi-directional serial data pin, the DOUT pin of the Le88266/286 device can be connected to its DIN pin.

If a low period of \overline{CS} contains less than 8 positive DCLK transitions, it is ignored. If it contains 8 to 15 positive transitions, only the last 8 transitions matter. If it contains 16 or more positive transitions, a hardware reset in the part occurs. If the chip is in the middle of a read sequence when \overline{CS} goes Low, data will be present at the DOUT pin even if DCLK has no activity.

3.3.1 Controlling Registers using read / modify / write.

In general, this coding method is not recommended for updating VoicePort device registers. The MPI interface is relatively slow speed, so operating on a local copy of this type of register data will provide higher performance.

In particular, some read / write registers are also accessed and modified by the internal state machine, especially on entering and exiting the Ringing States. This means that for these registers, a read modify write sequence can produce unpredictable results. The list of registers which must not be accessed using this technique is:

- [50/51h Write/Read Voice Path Gains, on page 77](#)
- [56/57h Write/Read System State, on page 78](#)
- [60/61h Write/Read Operating Functions, on page 80](#)
- [70/71h Write/Read Operating Conditions, on page 82](#)
- [A6/A7h Write/Read Converter Configuration, on page 88](#)
- [CA/CBh Write/Read Digital Impedance Scaling Network \(DISN\), on page 91](#)
- [E6/E7h Write/Read Switching Regulator Control, on page 100](#)
- [EA/EBh Write/Read Caller Identification Number Parameters, on page 102](#)

3.3.2 Interrupt Servicing in MPI Mode

The Le88266/286 device has a well-defined interrupt structure. All the interrupts in the Le88266/286 device can be masked. Interrupts are caused only when a status bit is unmasked and the status bit is subsequently set or toggles (depending on the interrupt).

The Le88266/286 device generates interrupts in response to a number of line supervision events. When an interrupt is generated, its status is placed in the [4D/4Fh Read Signaling Register, on page 75](#). Multiple interrupts can be reported in the signaling register. When the first interrupt occurs, the interrupt pin, INT, will be pulled Low to signal the external microprocessor that an interrupt has occurred. When the external microprocessor has serviced the interrupts by reading [4D/4Fh Read Signaling Register](#) and clearing the interrupt (Command 4Fh) or [CDh Read Transmit PCM/Test Data, on page 91](#) (if ATI is set), the INT pin will go High. An interrupt is generated whenever a signaling register status bit changes (1 to 0 or 0 to 1) and the corresponding mask bit in [6C/6Dh Write/Read Interrupt Mask Register, on page 82](#) is unmasked. Therefore, the software application is responsible for keeping track of the previous status and deciding the transition type (rising edge transition or falling edge transition). The interrupt pin drive mode can be programmed to be 3.3 V CMOS push/pull or open drain. Signaling status can also be polled without upsetting any pending interrupt status by using command 4Dh.

The following status bits related to channel 1 and channel 2 can cause an interrupt to occur:

CFAIL:	PCM Clock (PCLK) or 8 kHz frame sync (FS) failure
OCALMY:	Switching regulator Y over voltage / current indication
TEMPA ₁ :	Thermal Fault has been detected
IO2 ₁ :	Input 2 Status. The input value at IO2 ₁ has changed
CAD ₁ :	Cadencer interrupt when programmed on period is completed
CID ₁ :	Caller ID Buffer Ready
GNK ₁ :	Ground-key status has changed
HOOK ₁ :	Hook status has changed
DAT:	Measurement data available in XDAT register
OCALMZ:	Switching regulator Z over current indication
TEMPA ₂ :	Thermal Fault has been detected
IO2 ₂ :	Input 2 Status. The input value at IO2 ₂ has changed
CAD ₂ :	Cadencer interrupt when programmed on period is completed
CID ₂ :	Caller ID Buffer Ready
GNK ₂ :	Ground-key status has changed
HOOK ₂ :	Hook status has changed

Table 1 - Definitions of Status Bits

3.4 General Circuit Interface (GCI)

In GCI mode, this block carries both control and data on the same serial bus, replacing both MPI and PCM functionality. When the \overline{CS}/PG pin is connected to DGND and DCLK/S0 is static (not toggling), GCI operation is selected. The Le88266/286 device conforms to the GCI standard where data for eight GCI packets are combined into one serial bit stream. A GCI packet contains the control and voice data for the two analog channels of the Le88266/286 device. The Le88266/286 device sends Data Upstream out of the DU pin and receives Data Downstream on the DD pin. Data clock rate and frame synchronization information goes to the Le88266/286 device on the DCL (Data Clock) and FSC (Frame Sync.) input pins, respectively.

The GCI block does not support the wideband (16kHz) sampling mode.

3.4.1 GCI Format and Command Structure

The GCI interface provides communication of both control and voice data between the GCI highway and subscriber Voice Ports over a single pair of pins on the Le88266/286 device. A complete GCI frame is sent upstream on the DU pin and received downstream on the DD pin every 125 μ s. Each frame consists of eight 4-byte GCI packets that contain voice and control information for 8 pairs of channels. The overall structure of the GCI frame is shown in [Figure 8](#). The four-time slot GCI packets contain the following:

- Two voice-data channels
 - B1 provides compressed PCM data for Voice Channel 1
 - B2 provides compressed PCM data for Voice Channel 2
- One Monitor (M) channel for reading and writing control data and coefficients to the chip set in combination with the MX and MR bits in the Signaling and Control channel
- One Signaling and Control (SC) channel containing a 6-bit Command/Indicate (C/I) field for real time control information and a two-bit field with Monitor Receive and Monitor Transmit (MR and MX) bits for hand-shaking functions linked to the Monitor channel. All principal signaling (real-time critical) information is carried on the C/I channel.

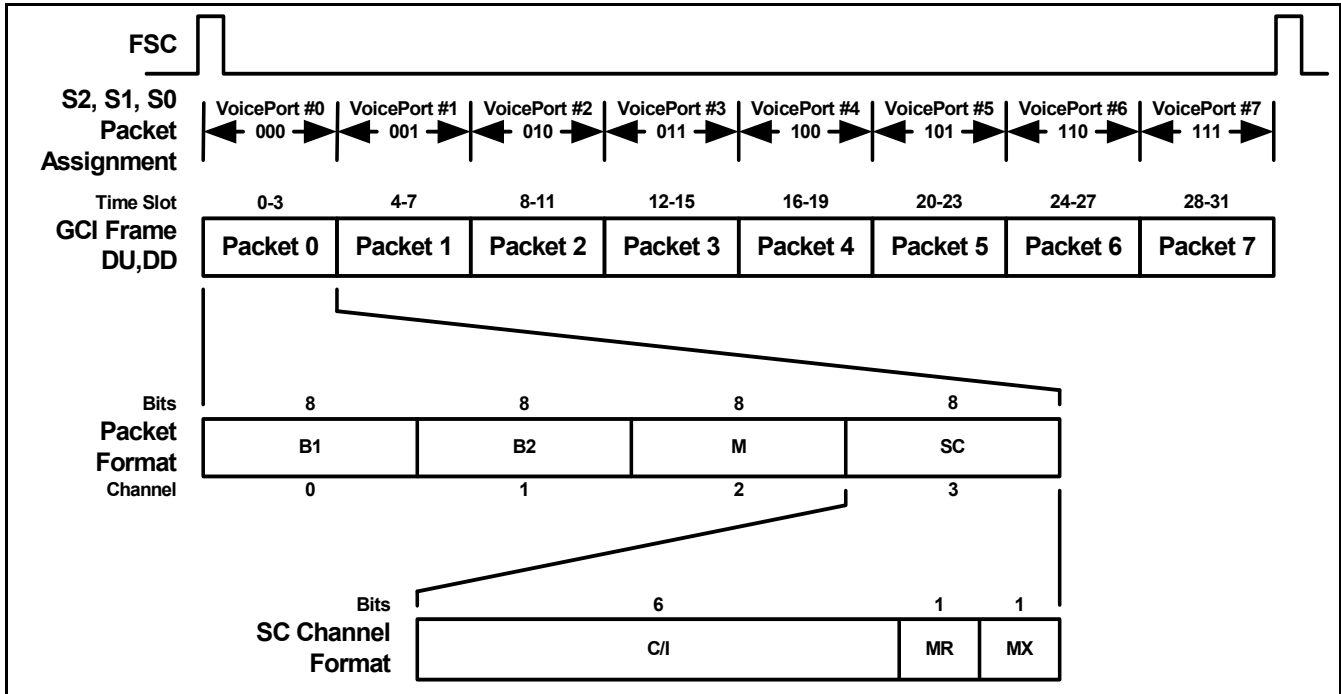

Figure 8 - Multiplexed GCI Time Slot Structure

In the packet control block (shown in [Figure 9](#)), the Frame Sync (FSC) pulse identifies the beginning of the Transmit and Receive frames and all GCI packets are referenced to it. Voice (B1 and B2), C/I, and Monitor data are sent to the Upstream Multiplexer where they are combined and serially shifted out of the DU pin in the selected GCI packet time slots. The Downstream Demultiplexer uses the same packet control block information to demultiplex the incoming GCI packet into separate voice (B1 and B2), C/I, and Monitor channels.

$\overline{\text{INT/S2}}$	DIN/S1	DCLK/S0	GCI Packet
DGND	DGND	DGND	0
DGND	DGND	DVDD	1
DGND	DVDD	DGND	2
DGND	DVDD	DVDD	3
DVDD	DGND	DGND	4
DVDD	DGND	DVDD	5
DVDD	DVDD	DGND	6
DVDD	DVDD	DVDD	7

Table 2 - GCI Packet Assignment Codes

The external clock applied to the DCL pin must be either 2.048 MHz or 4.096 MHz. The Le88266/286 device determines the incoming clock frequency and adjusts internal timing automatically to accommodate single or double clock rates. Correct clock detection can be determined by reading the CSEL bits in [46/47h Write/Read Device Configuration Register on page 73](#). Upstream and Downstream Data is always transmitted at a 2.048 MHz data rate.

The Le88266/286 device supports access to all eight GCI packets (16 analog channels). The S0, S1 and S2 GCI Packet Assignment pins on the Le88266/286 device are encoded as shown in [Table 2](#).

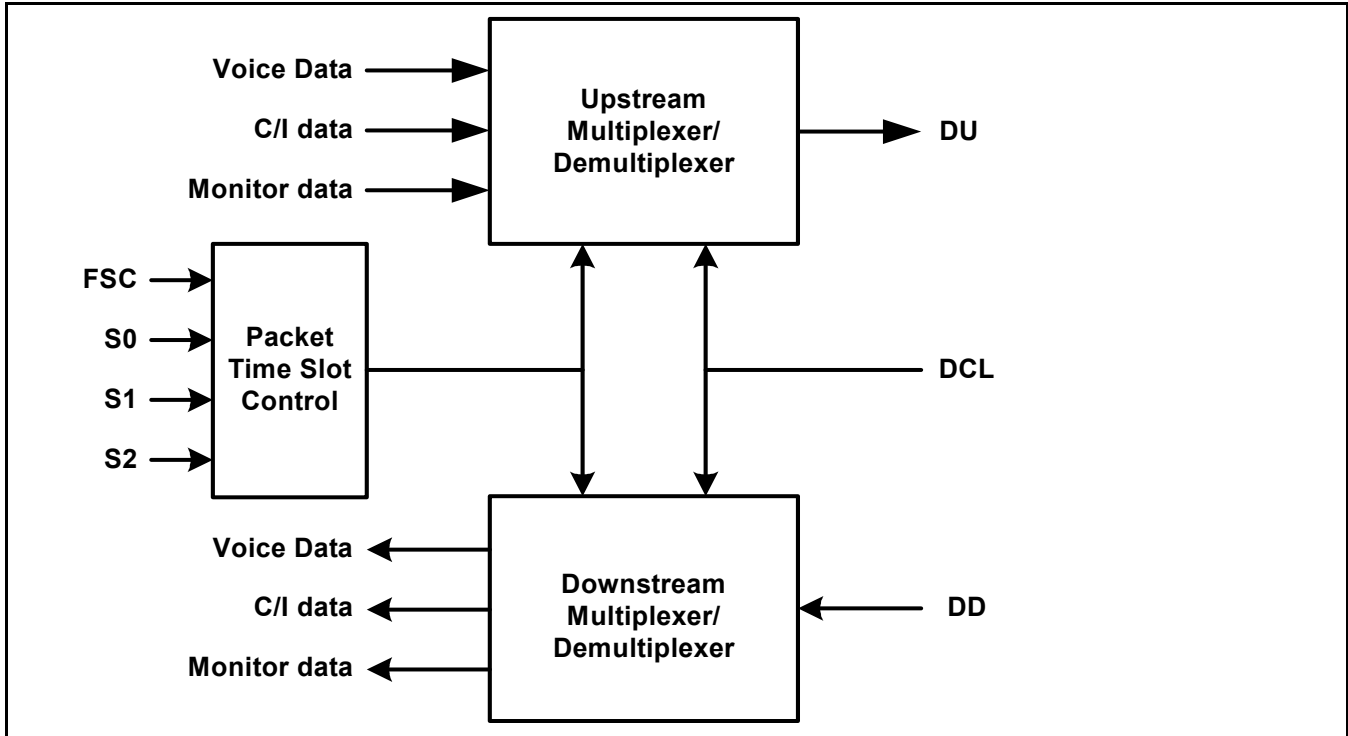

Figure 9 - GCI Interface and Packet Time Slot Selection

3.4.2 Signaling and Control (SC)

The downstream and upstream SC channels are continuously sending state control and loop supervision data every frame to and from the Le88266/286 device in the C/I field. This allows the upstream processor to have immediate access to the VoicePort line status. The MR and MX bits are used for handshaking during data exchange on the monitor channel.

The format of the downstream control (C) field is shown in [Table 3](#). The Le88266/286 device receives the most significant bit first.

Channel	D7	D6	D5	D4	D3	D2	D1	D0
1	A	POLNR	System_State[3:0]				MR	MX

Table 3 - Down Stream SC Channel Definition

- A: Channel address bit.
 - 0: Select Channel 1 as the downstream data destination.
 - 1: Select Channel 2 as the downstream data destination.
- POLNR: VoicePort Feed Polarity
 - 0: Normal Polarity feed - TipD more positive than RingD
 - 1: Reverse Polarity feed - RingD more positive than TipD
- SS3,-SS0: System State. Valid system states are listed here. All other codes are reserved.
 - 0000: Disconnect, ACT = 0
 - 0001: Tip Open, ACT = 0
 - 0010: Ring Open, ACT = 0

- 0011: Active Low Battery, ACT = 1
- 0100: Idle, ACT = 0
- 0101: Longitudinal Test, ACT = 1
- 0110: Metallic Test, ACT = 1
- 0111: Balanced Ringing, ACT = 1
- 1000: Low Gain, ACT = 1
- 1010: Unbalanced Ringing, ACT = 1
- 1011: Active Mid Battery, ACT = 1
- 1111: Shutdown, ACT = 0

See [56/57h Write/Read System State, on page 78](#) for more description of the system states.

[Figure 10](#) shows a flow chart describing the transmission protocol for the downstream channel, which provides a high level of security for the C field data exchange. Whenever the received pattern of C bits 6 through 1 is different from the pattern currently in the C input register, the new pattern is loaded into a secondary C register, and a latch is set. When the next pattern is received (in the following frame) while the latch is set, the following rules apply:

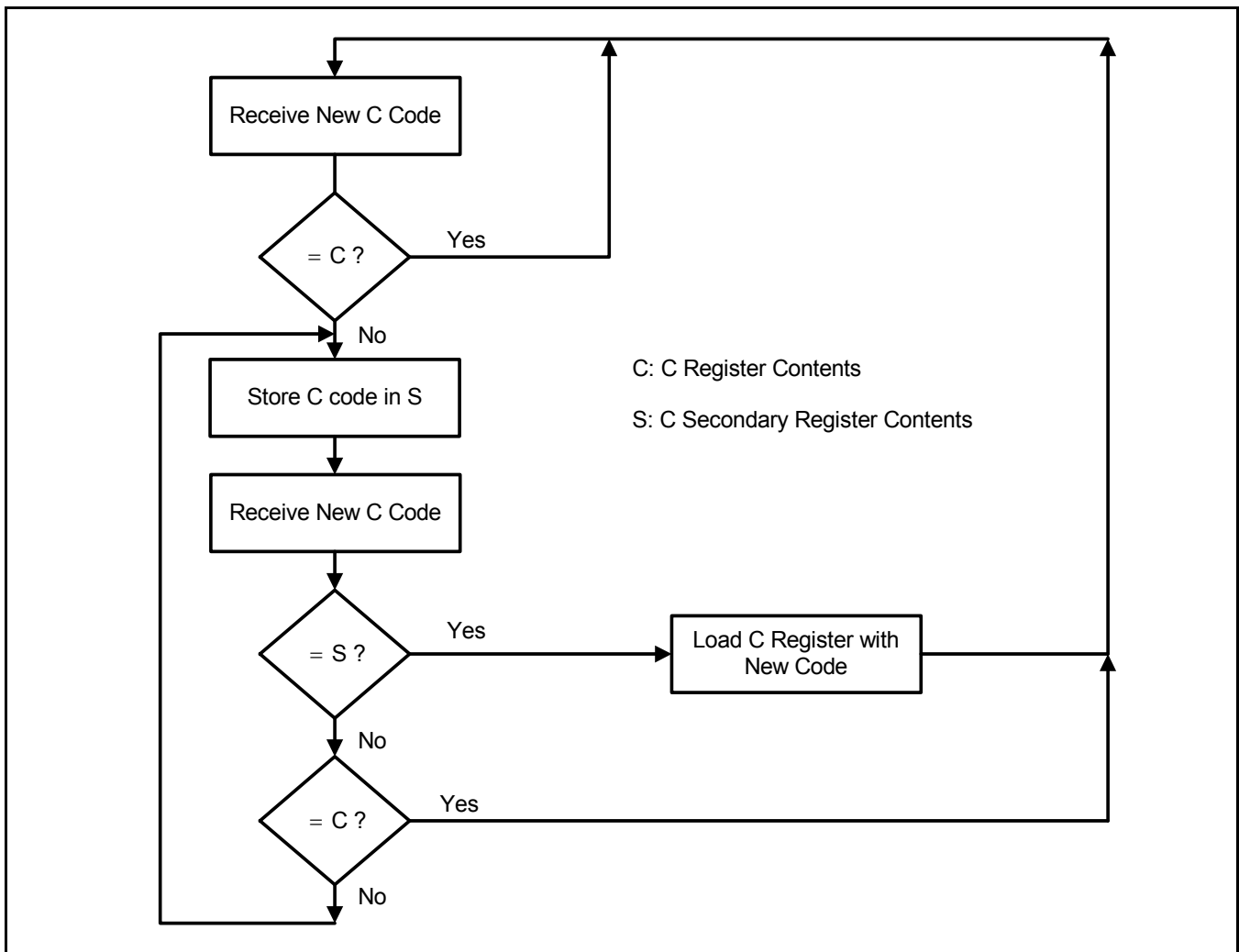

Figure 10 - Security Procedure For C Downstream Byte

- If the received pattern corresponds to the pattern in the secondary register, the new pattern is loaded into the C register, and the latch is reset.
- If the received pattern is different from the pattern in the secondary register and different from the pattern currently in the C register, the newly received pattern is loaded into the secondary C Register, and the latch remains set.

- If the received pattern is the same as the pattern currently in the C register, the C register is unchanged, and the latch is reset.

The format of the upstream indication (I) field is shown in [Table 4](#). The Le88266/286 device transmits the I field most significant bit first each frame.

D7	D6	D5	D4	D3	D2	D1	D0
SLCX ₂	GNK ₂	HOOK ₂	SLCX ₁	GNK ₁	HOOK ₁	MR	MX

Table 4 - Upstream SC Channel

SLCX ₂	Summary output of the Channel 2 Signaling Register 1: One or more of the unmasked bits in the Signaling Register has toggled. 0: None of the unmasked bits in the Signaling Register has toggled. This is a logic “or” of TEMP _{A2} , DAT, IO ₂₂ , CAD ₂ , GNK ₂ , HOOK ₂ and OCALM ₂ . This bit is reset when the signalling register is read using the 4F read and clear interrupt from 4D/4Fh Read Signaling Register, on page 75 .
GNK ₂ :	Indication if a ground connection is taking place 1: Ground connection 0: No ground connection
HOOK ₂ :	Indication of loop condition 1: Subscriber is off-hook 0: Subscriber is on-hook
SLCX ₁	Summary output of the Channel 1 Signaling Register 1: One or more of the unmasked bits in the Signaling Register has toggled. 0: None of the unmasked bits in the Signaling Register has toggled. This is a logic “or” of TEMP _{A1} , CF _{AIL} , IO ₁₁ , CAD ₁ , GNK ₁ , HOOK ₁ and OCALM ₁ . This bit is reset when the signalling register is read using the 4F read and clear interrupt from 4D/4Fh Read Signaling Register, on page 75 .
GNK ₁ :	Indication if a ground connection is taking place 1: Ground connection 0: No ground connection
HOOK ₁ :	Indication of loop condition 1: Subscriber is off-hook 0: Subscriber is on-hook

Data from the loop supervision circuitry (with applicable debouncing) is latched by a derivative of Frame Sync every 125 μs. This real-time latched data is transmitted upstream in the I field every frame (125 μs). Note that it is not the data in the Signaling Register. Hence masking or unmasking of the HOOK and GNK interrupts in the interrupt mask register will not affect the HOOK and GNK data in the SC channel.

3.4.3 Monitor Channel Protocol

The Monitor (M) channel (see [Figure 11](#)) loads the Le88266/286 device internal registers, reads the status of the device and the contents of the internal registers, and provides supplementary signaling. Information is transferred on the Monitor Channel using the MR and MX bits of the third (SC) channel to provide a reliable method of data exchange between the higher level processor and the Le88266/286 device (see [Figure 11](#)).

The monitor channel is the third channel in the 4-channel packet sent and received every 125 μs. A monitor command consists of one address byte and one or more command bytes followed by additional bytes of input data. The command can be followed by the Le88266/286 device sending data bytes upstream via the DU pin.

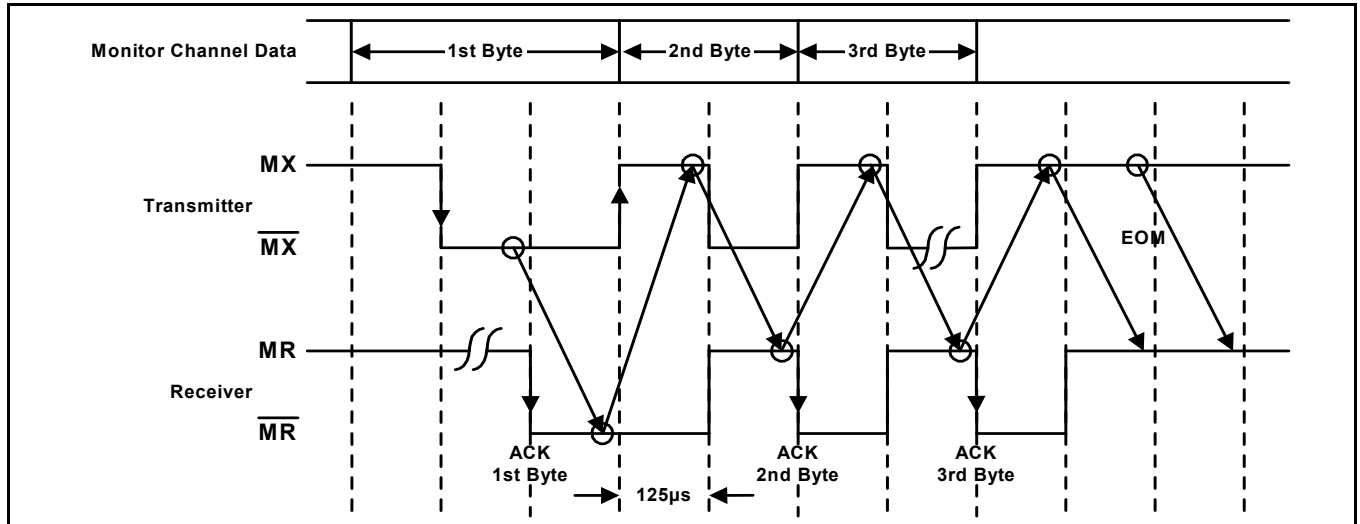

Figure 11 - Maximum Speed Monitor Handshake Timing

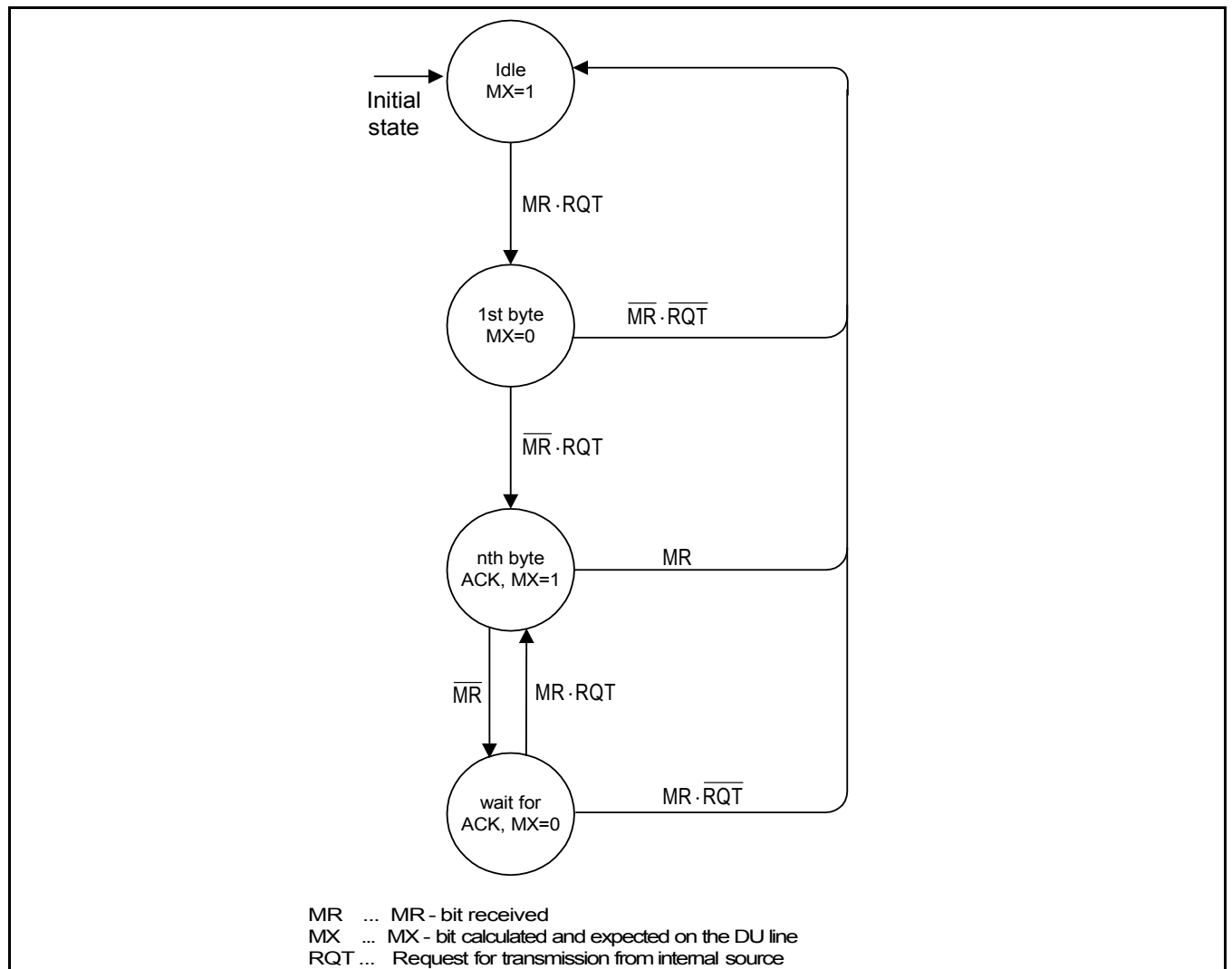

Figure 12 - Monitor Transmitter Mode Diagram

- An inactive (High) MX and MR pair bit for two or more consecutive frames shows an idle state on the monitor channel and the end of message (EOM).
- [Figure 11](#) shows that transmission is initiated by the transition of the transmitter MX bit from the inactive to the active state. The transition coincides with the beginning of the first byte sent on the monitor channel. The receiver acknowledges the first byte by setting MR bit to active and keeping it active for at least one more frame.
- The same data must be received in two consecutive frames in order to be accepted by the receiver.
- The same byte is sent in each of the succeeding frames until either a new byte is transmitted, the message ends, or an abort occurs. Any abort command resets any pending commands in the Le88266/286 device. The device remains in the previous configuration and is ready to receive a new command.
- Any false MX or MR bit received by the receiver or transmitter leads to a request-for-abort or an abort, respectively.
- To obtain maximum data transfer speed, the transmitter anticipates the falling edge of the receiver's acknowledgment as shown in [Figure 11](#).

[Figure 12](#) and [Figure 13](#) are state diagrams that define the operation of the monitor transmitter and receiver sections in the Le88266/286 device.

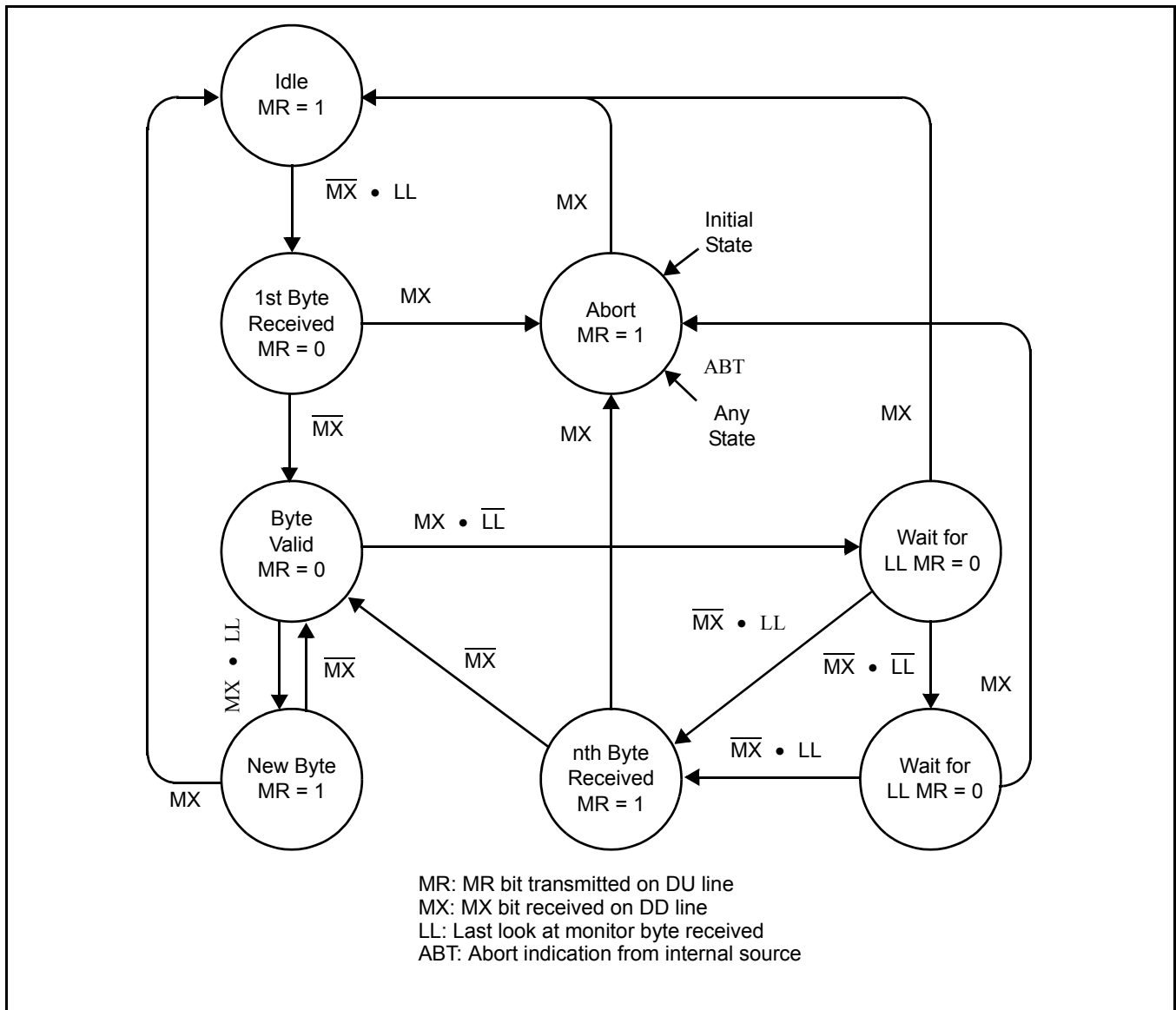

Figure 13 - Monitor Receiver Mode Diagram

3.4.4 Programming with the Monitor Channel

The Le88266/286 device uses the monitor channel for the transfer of status or mode information to and from higher level processors. The higher level processor is synchronized to the Le88266/286 device using the time slot straps S0, S1 and S2.

The messages transmitted in the monitor channel have different structures. The first byte of monitor channel data in the GCI format indicates the address of the device either sending or receiving the data. All monitor channel messages to/from the Le88266/286 device begin with this address byte:

Bit	7	6	5	4	3	2	1	0
Address	1	0	0	A	B	0	0	C

- A
- 0: Channel 1 is the source (upstream) or destination (downstream)
 - 1: Channel 2 is the source (upstream) or destination (downstream)

- B
- 0: Data destination determined by A
 - 1: Both Channel 1 and 2 receive the data

- C
- 0: Address for channel identification command
 - 1: Address for all other commands

Transmission in the GCI monitor channel starts with an address byte followed by a command byte. If the command byte specifies a write, from 1 to 14 additional data bytes can follow (see [Table 5](#)). If the command byte specifies a read, additional data bytes can follow. The Le88266/286 device responds to the read command by sending out the original address byte and up to 14 bytes upstream that contain the information requested by the upstream controller. Generic byte transmission sequence over the GCI monitor channel is shown in [Table 5](#).

GCI Monitor Channel	
Downstream	Upstream
ADDRESS Control byte, write Data byte 1* • Data byte m* ADDRESS Control byte, read $m \leq 14$	 Data byte 1 • Data Byte n* $n \leq 14$

Table 5 - Monitor Byte Transmission Sequence

Notes:

* May or may not be present

3.4.5 Channel Identification Command (CIC)

When the monitor channel address byte is 80H or 90H, a command of 00H is interpreted by the Le88266/286 device as a two-byte Channel Identification Command (CIC).

The format for this command is shown next:

	D ₇	D ₆	D ₅	D ₄	D ₃	D ₂	D ₁	D ₀
Address Byte	1	0	0	A	0	0	0	0
Command Byte	0	0	0	0	0	0	0	0

A

- 0: Channel 1 is the destination
- 1: Channel 2 is the destination

Immediately after the last bit of the CIC command is received, the Le88266/286 device responds with the two-byte channel ID code indicating an analog transceiver device type in bits 6 and 7 of byte 2, with the following configuration options:

	D ₇	D ₆	D ₅	D ₄	D ₃	D ₂	D ₁	D ₀
Byte 1	1	0	0	A	PCN5	PCN4	PCN3	PCN2
Byte 2	1	0	0	0	0	1	1	1

A

- 0: Channel 1 is the destination
- 1: Channel 2 is the destination

PCN[5:2]

- Product Code Number
- Ch Le88266 device
- Dh Le88286 device

When the Le88266/286 device has completed transmission of the channel ID information, it sends an EOM (MX = 1 for two successive frames) on the upstream C/I channel. The Le88266/286 device also expects an EOM to be received on the downstream C/I channel before any further message sequences are received.

3.4.6 General Structure of Other Commands

When the monitor channel address byte is 81h, 89h, 91h, or 99h, the command byte is interpreted by the Le88266/286 device as either a Transfer Operation (TOP), Status Operation (SOP), or a Coefficient Operation (COP).

	D ₇	D ₆	D ₅	D ₄	D ₃	D ₂	D ₁	D ₀
Address Byte	1	0	0	A	B	0	0	1

A

- 0: Channel 1 is the source (upstream) or destination (downstream)
- 1: Channel 2 is the source (upstream) or destination (downstream)

B

- 0: Data destination determined by A
- 1: Both Channel 1 and 2 receive the data

Commands are sent to the Le88266/286 device to:

- Read the status of the system without changing its operation
- Write/read the Le88266/286 device operating mode
- Write/read filter coefficients

3.5 Internal Configuration Registers

The Le88266/286 device contains a block of Internal Configuration Registers (ICR). For correct operation, some of the bits in these registers must be written during operation. The general structure, command codes and operation of these registers is described on page 103.

Access to these registers is required to provide smooth transitions from disconnect to idle or active states (page 26), enable line voltage sensing in the Disconnect state (page 26), correctly configure the DC feed (page 27) and to control the test load switch on the Le88286DLC (page 32). Details of these settings are provided in the corresponding sections.

3.6 Input / Output Block

This block controls general-purpose pins that can be configured by the user as inputs, outputs, or relay drivers. CMOS-compatible I/O pins (I/O1 and I/O2) are provided per channel. I/O1 can act either as a standard digital input or as a high current CMOS output capable of directly driving a 150-mW 3-V relay with an external catch diode. I/O2 is a standard digital I/O pin that can also generate interrupts when configured as an input. The pins are accessed using Command [52/53h Write/Read Input/Output Data Register, on page 77](#). The direction of the I/O pins (input or output) is specified by programming [54/55h Write/Read Input/Output Direction Register, on page 78](#).

3.7 Voice Signal Processors

This block performs digital signal processing for the transmission and reception of voice. It includes G.711 compression/decompression, impedance matching, filtering, gain control, DTMF generation and general-purpose tone generators for each channel. Additionally caller ID FSK generation and metering generation are provided.

This block performs the codec and filter functions associated with the four-wire section of the subscriber line circuitry in a digital switch. These functions involve converting an analog voice signal into digital PCM samples and converting digital PCM samples back into an analog signal. During conversion, digital filters are used to band-limit the voice signals.

The user-programmable filters perform the following functions:

- Sets the receive and transmit gain
- Performs the transhybrid balancing function
- Permits adjustment of the two-wire termination impedance
- Provides frequency attenuation adjustment (equalization) of the receive and transmit paths

All programmable digital filter coefficients can be calculated using Microsemi's WinSLAC software. The PCM codes can be either 16-bit linear two's-complement or 8-bit companded A-law or μ -law.

3.7.1 Overview of Digital Filters

Several of the blocks in the signal processing section are user programmable. These allow the user to optimize the performance of the Le88266/286 device for the system. [Figure 14](#) shows the Le88266/286 device signal processing for one channel and indicates the programmable blocks and how this section interfaces with the high voltage line driver and line sensing circuits.

The advantages of digital filters are:

- High reliability
- No drift with time or temperature
- Unit-to-unit repeatability
- Superior transmission performance
- Flexibility
- Maximum bandwidth for V.90 modems

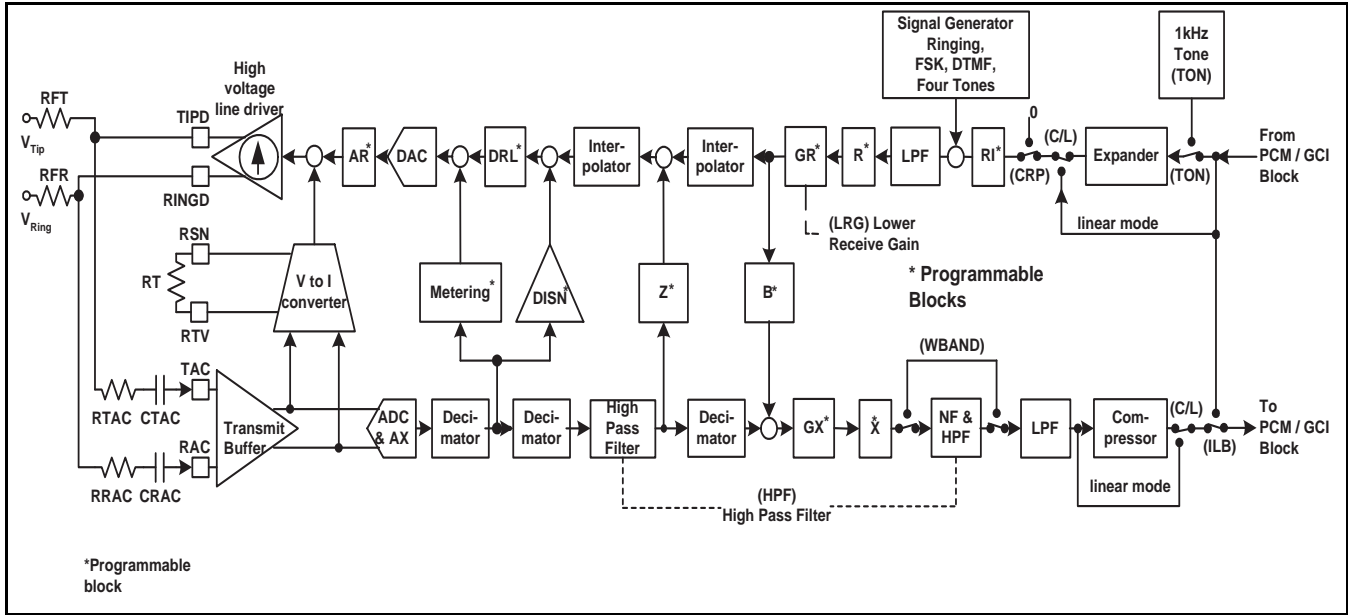

Figure 14 - Voice Signal Processing Block Diagram

3.7.2 Analog Impedance Synthesis

The analog impedance synthesis loop is comprised of the high voltage line driver, the AC sense path components, the transmit amplifier, and a voltage to current converter. Nominally, this converter uses an external resistor, R_T . R_T synthesizes the nominal impedance in the analog domain.

3.7.3 Two-Wire Impedance Matching

Two feedback paths in the voice signal processor modify the two-wire input impedance by providing a programmable feedback path from the AC sense path to the line driver outputs.

The DISN path is comprised of the voice A/D and its first stage of decimation, a Digital Impedance Scaling Network (DISN), and the voice DAC. The DISN synthesizes a portion of the ac impedance which appears in parallel with R_T and is used to modify the impedance set by the external analog network. The DISN is controlled by an 8-bit word. [See CA/CBh Write/Read Digital Impedance Scaling Network \(DISN\), on page 91.](#)

The Z filter is a programmable digital filter providing an additional path and programming flexibility over the DISN in modifying the transfer function of the synthesis loop. Together, the R_T , DISN, and Z-Filter enable the user to synthesize virtually all required telephony device input impedances. [See 98/99h Write/Read Z Filter FIR Coefficients, on page 87.](#) and [9A/9Bh Write/Read Z Filter IIR Coefficients, on page 87.](#)

3.7.4 Frequency Response Correction and Equalization

The voice signal processor contains programmable filters in the receive (R) and transmit (X) directions that may be programmed for line equalization and to correct any attenuation distortion caused by the Z filter. [See 8A/8Bh Write/Read R Filter Coefficients, on page 86.](#) and [88/89h Write/Read X Filter Coefficients, on page 85.](#)

3.7.5 Transhybrid Balancing

The voice signal processor's programmable B filter is used to adjust transhybrid balance. The filter has a single pole IIR section (BIIR) and an eight-tap FIR section (BFIR), both operating at 16 kHz. [See 86/87h Write/Read B Filter FIR Coefficients, on page 84.](#) and [96/97h Write/Read B Filter IIR Coefficients, on page 87.](#)

3.7.6 Gain Adjustment

The transmit path has two programmable gain blocks. Gain block AX is an analog gain of 0 dB or 6.02 dB (unity gain or gain of 2.0), located immediately before the A/D converter. [See 50/51h Write/Read Voice Path Gains, on page 77.](#) GX is a digital gain block that is programmable from 0 dB to +12 dB, with a worst-case step size of 0.1 dB for gain settings below +10 dB, and a worst-case step size of 0.3 dB for gain settings above +10 dB. The filters provide a net gain in the range of 0 dB to 18 dB. [See 80/81h Write/Read GX Filter Coefficients, on page 83.](#)

The receive voice path has three programmable gain blocks. GR is a digital loss block that is programmable from 0 dB to 12 dB, with a worst-case step size of 0.1 dB. [See 82/83h Write/Read GR Filter Coefficients, on page 83.](#) DRL is a digital loss block of 0 dB or 6.02 dB. AR is an analog gain of 0 dB or 6.02 dB (unity gain or gain of 2) or a loss of 6.02 dB (gain of 0.5), located immediately after the D/A converter. [See 50/51h Write/Read Voice Path Gains, on page 77.](#) This provides a net loss in the range of 0 dB to 18 dB. AR is limited to 0 or -6.02 dB when DRL is 0 dB, and +6.02 dB or 0 dB if DRL is 6.02 dB of loss.

Metering is affected by the AR gain block. To achieve the specified levels, the DRL loss is enabled, and AR gain is applied whenever metering is used.

3.7.7 Transmit Signal Processing

In the transmit path (A/D), the AC Tip - Ring analog input signal is sensed by the TAC and RAC pins, buffered, amplified by the analog AX gain and sampled by the A/D converter, filtered, companded (for A-law or μ -law), and made available to the PCM or GCI blocks. Linear mode is only available in the PCM/MPI mode. If linear format is selected, the 16-bit data will be transmitted in two consecutive time slots starting at the programmed time slot. The B, X, and GX digital filter blocks are user-programmable digital filter sections with coefficients stored in the coefficient RAM. The B, X, and GX filters can also be operated from an alternate set of default coefficients stored in ROM. [See 60/61h Write/Read Operating Functions, on page 80.](#)

The first high-pass filter is for DC rejection, and the second high pass and notch filters reject low frequencies such as 50 Hz or 60 Hz. In wideband mode, the second high pass and notch filters are bypassed as shown in [Figure 14, Voice Signal Processing Block Diagram, on page 21.](#) All of these filters may be disabled with the DHP bit in command [70/71h Write/Read Operating Conditions, on page 82.](#)

3.7.8 Receive Signal Processing

In the receive path (D/A), the digital signal is expanded (for A-law or μ -law), filtered, interpolated, converted to analog, and driven onto the TIPD and RINGD pins by the high voltage line driver. The DRL, DISN, Z, R, and GR blocks are user-programmable filter sections with their coefficients stored in the coefficient RAM, while AR is an analog amplifier. The Z, R, GR and RI filters can also be operated from an alternate set of default coefficients stored in ROM. [See 60/61h Write/Read Operating Functions, on page 80.](#)

3.7.9 Programmable Filters

The filter coefficients that the user sends to the voice ALU are in a form known as Canonical Signed Digits (CSDs). The coefficients take the following general form:

$$h = I_0 + C_1 \cdot 2^{-m_1} \cdot (1 + C_2 \cdot 2^{-m_2} \cdot (1 + I_3 \cdot C_3 \cdot 2^{-m_3} \cdot (1 + I_4 \cdot C_4 \cdot 2^{-m_4})))$$

- where:
- C_j = -1 or +1 (represented as 1 or 0 in user programming)
 - m_j = 0, 1, 2,... or 7 (user programming)
 - I₀ = 1 for GX; I₀ = 0 for all other coefficients
 - I₄ = 1 for 4 • CSD coefficients; I₄ = 0 otherwise
 - I₃ = 1 for 3 and 4 CSD coefficients; I₃ = 0 for 2 CSD coefficients

3.7.10 Calculating Coefficients with WinSLAC™ Software

The WinSLAC™ software is a program that models the Le88266/286 device, the line conditions, and the external VoicePort components to calculate the coefficients of the programmable filters and predict important transmission performance plots.

The following parameters relating to the desired line conditions and the external components are provided as input to the program:

- Line impedance or the balance impedance of the line is specified by the local telephone system.
- Desired two-wire impedance that is to appear at the line card terminals of the exchange.

- Tabular data for templates describing the frequency response or attenuation distortion limits of the design.
- Relative analog signal levels for both the transmit and receive two-wire signals.
- Component values for the analog portion of the VoicePort.
- Two-wire return loss template that is usually specified by the local telephone system.
- Four-wire return loss template that is usually specified by the local telephone system.

The output from the WinSLAC program includes the coefficients of the AR, AX, DRL, DISN, GR, GX, Z, R, X, and B filters as well as transmission performance plots of stability, input impedance, two-wire return loss, receive and transmit path frequency responses, and four-wire return loss.

Pre-computed coefficient sets supporting worldwide markets are available from Microsemi for most standard configurations.

The coefficient sets are formatted in a way that allows easy integration with the VP-API-II software using the Profile Wizard or VP Script demonstration software.

3.7.11 Speech Coding

The A/D and D/A conversion follows either the A-law or the μ -law standard as defined in ITU-T Recommendation G.711. A-law or μ -law operation is programmed using command [60/61h Write/Read Operating Functions, on page 80](#). Alternate bit inversion is performed as part of the A-law coding. In PCM/MPI mode linear code is an option on both the transmit and receive sides of the device. Linear code is also selected using Command 60/61h. Two successive time slots are required for linear code operation. The linear code is a 16-bit two's-complement number which appears sign bit first on the PCM highway.

3.7.12 Wideband Codec Mode

The Le88266/286 device can be operated in a Wideband mode when using the PCM/MPI control option. GCI does not support wideband mode. The wideband mode is selected with the WBAND bit in command [4A/4Bh Write/Read Channel Enable and Operating Mode Register, on page 74](#) and it affects both channels of the device. In this mode, the nominal voice bandwidth is doubled to 300Hz to 7000Hz to provide better voice quality. In this mode, internal clocks are doubled, increasing the sampling rates of the internal digital filters. One stage of interpolation and decimation is skipped so that the DSP data can be sent to the A/D converter, and part of the transmit high pass filter and notch filter are disabled. The coefficients of the Le88266/286 must be reprogrammed from the nominal values in Wideband mode. In this mode the increased data rate is processed by accessing a second set of timeslots equally spaced in the frame. Linear data should be used in the Wideband mode.

3.7.13 Voice Path Test States and Operating Conditions (per channel)

The Le88266/286 device supports testing by providing test states and special operating conditions as shown in [Figure 14, Voice Signal Processing Block Diagram, on page 21](#) (see [70/71h Write/Read Operating Conditions, on page 82](#)).

Cutoff Transmit Path (CTP): When CTP = 1, DXA and TSCA are high impedance and the transmit time slot does not exist. This state takes precedence over the Interface Loopback (ILB).

Cutoff Receive Path (CRP): When CRP = 1, the receive signal is forced to 0 just ahead of the low pass filter (LPF) block. This state blocks the 1 kHz receive tone (TON). The signal generators can still be used to send signals in the receive path.

High Pass Filter disable (HPF): When HPF = 1, all of the high pass and notch filters in the transmit path are disabled.

Lower Receive Gain (LRG): When LRG = 1, an extra 6.02 dB of digital loss is inserted into the receive path.

Interface Loopback (ILB): When ILB = 1, data from the TSA receive time slot is looped back to the TSA transmit time slot. Any other data in the transmit path is overwritten.

1 kHz Receive Tone (TON): When TON = 1, a 1 kHz "digital milliwatt" (2 kHz in Wideband mode) is injected into the receive path, replacing any receive signal from the TSA.

3.8 Signal Generation and Cadence Control

Up to five digital signal generators are available for each channel (see [Figure 15](#)) that are summed into the receive path, as shown in [Figure 14](#). They are configured with commands [D2/D3h Write/Read Signal Generator A, B and Bias Parameters, on page 94](#) and [D4/D5h Write/Read Signal Generator C and D Parameters, on page 96](#) and controlled with command [DE/DFh Write/Read Signal Generator Control, on page 97](#) in combination with the cadencer configuration in [E0/E1h Write/Read Cadence Timer, on page 98](#).

The Bias generator produces a DC bias that can be used to provide DC offset during ringing or DC test signals during diagnostic tests. This generator is automatically enabled when entering the ringing state.

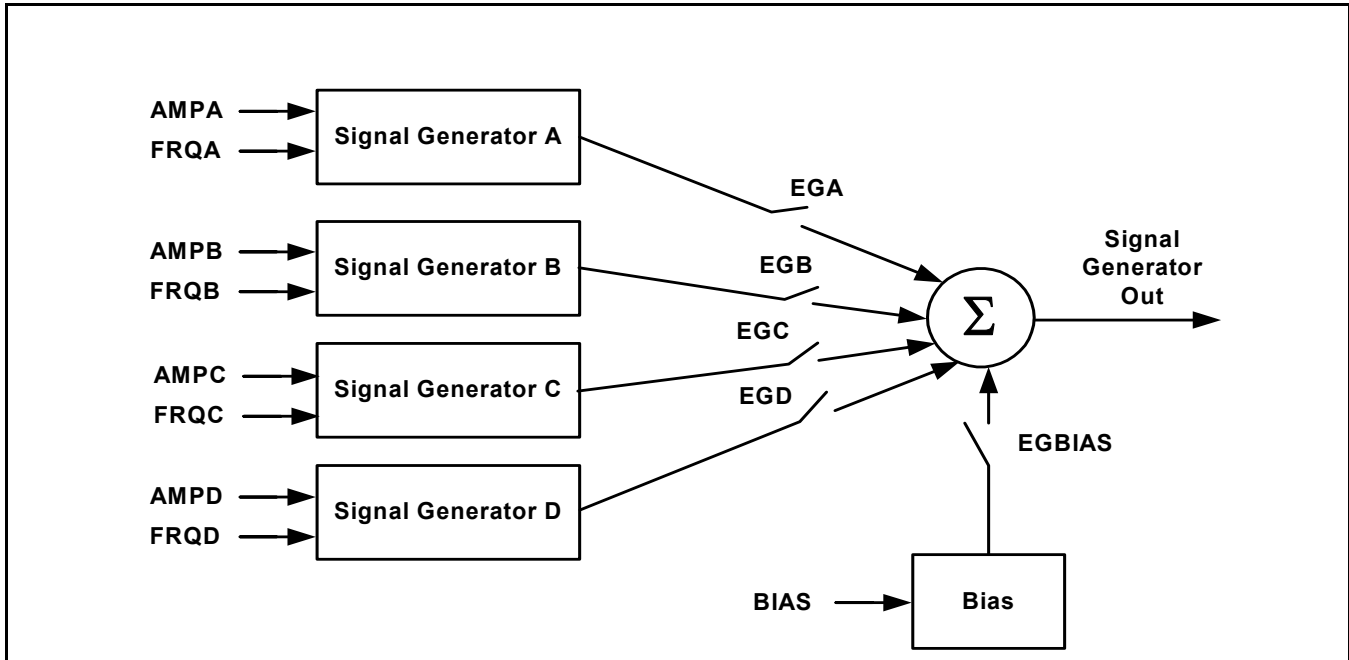

Figure 15 - Signal Generator

Signal Generator A is used for ringing signal generation and is automatically enabled when entering the ringing state. It can produce sinusoidal or trapezoidal signals. When generating a trapezoid, Signal Generator B is not available and some of its parameters are used to configure the trapezoid. For more details on trapezoidal ringing, see the Trapezoidal Ringing Application Note (Document ID #081476).

In addition, Signal Generator A can be used with the Bias Generator to produce slow ramps. This allows a complex sequence of diagnostic test voltages to be generated in a controlled manner without generating unwanted transients on the line.

When available, Signal Generator B produces a programmable sine wave and can be used for call progress tone generation.

Signal generators C and D are also used for call progress tone generation, DTMF generation and can be configured for FSK based Caller ID generation in combination with command [EA/EBh Write/Read Caller Identification Number Parameters, on page 102](#).

Each generator has independent frequency and amplitude parameters. The frequency accuracy is basically the same as the crystal accuracy of the system. The amplitude accuracy and spectral purity are limited only by the voice DAC.

3.8.1 Cadencing

The signal generator may be sequenced with an on and off time controlled by the user. This feature allows the Le88266/286 device to automatically cadence the ringing bursts. The cadence function can also be used to control the general purpose signal generator during the Active state to send call progress or other specialized tones. Additionally, the sequencer may be used as a general purpose timer/counter which can send interrupts to the user’s micro controller after timing out events.

The cadencer has 5 ms resolution, with a maximum on time of 10.24 s and a maximum off time of 10.24 s. [See E0/E1h Write/Read Cadence Timer, on page 98](#). It is enabled with the SGCAD bit in command [DE/DFh Write/Read Signal Generator Control, on page 97](#). The CAD bit in the Signalling register is set at the end of the on period, and this event can generate an interrupt if the bit is unmasked.

3.8.2 Calling Number Identification (CID)

The VP-API-II uses the CID block in combination with a sophisticated sequencer to easily implement any international caller ID procedure. The sequencer supports state selection, time delays and conditional events to support any Type 1 or Type 2 CID.

The CID block in the device uses tone generators C and D for each channel to generate phase continuous 1200 baud FSK tones for on or off hook data transmission such as caller ID information. The duration of each (bit) tone is fixed at 0.833 ms (1200 baud).

When the CID bit is 0 (space), the transmitted tone is from signal generator C.

When the CID bit is 1 (mark), the transmitted tone is from signal generator D.

The typical configurations for signal generators C and D when used for CID is shown in [Table 6](#).

The Bell 202 / GR-30 frequencies are used in the US market, and the V.23 frequencies are used in most other international markets. The signal generator amplitude may need to be adjusted depending on the programmed loss plan. Data transmission levels are normally specified as -13.5 dBm +/-1.5 dB. The default amplitude of -7 dBm0 can be used if the programmed receive relative level is -6 or -7 dB. The amplitudes of AMPC and AMPD are normally set equal, and the dBm0 level from the generator is given by:

$$AC(\text{dBm0}) = 20 \cdot \log\left(\frac{|AMPCd|}{22827}\right)$$

$$AD(\text{dBm0}) = 20 \cdot \log\left(\frac{|AMPDd|}{22827}\right)$$

The programmed parameters FRQC and FRQD can be determined with the following equations:

$$FRQCh = (FC \cdot 2.73)h$$

$$FRQDh = (FD \cdot 2.73)h$$

From the CID block point of view, once generators C and D have been programmed, the CID generation is configured and can be monitored using command [EA/EBh Write/Read Caller Identification Number Parameters, on page 102](#) which allows control of framing, end of message, and disabling the block. Information to be transmitted is received from the MPI as a string of characters using command [E2/E3h Write/Read Caller Identification Number Data, on page 98](#), which is a 2 byte deep buffer, allowing a 10 ms polling rate to support the real time requirements. Each character is 8 bits wide, and is assumed to include appropriate parity information according to the character set being used. If framing is enabled, for each character, the CID block first transmits a start bit, then it serially transmits the 8-bit character, LSB first, followed by a stop bit, giving a total of 10 bits sent for each character. The CID block sets the CID bit in the signaling register whenever it needs data to transmit, and this can generate an interrupt if the bit is unmasked.

Parameter	Number of Bits	Value	Description
FRQC	14	1777h	2200 Hz Bell 202 GR-30 space frequency (Default)
FRQC	14	1666h	2100 Hz ITU V.23 space frequency
AMPC	15	27D4h	-7 dBm0 level (Default)
FRQD	14	0CCDh	1200 Hz Bell 202 GR-30 mark frequency (Default)
FRQD	14	0DDEh	1300 Hz ITU V.23 mark frequency
AMPD	15	27D4h	-7 dBm0 level (Default)

Table 6 - CID Tone Programming

Exact preamble and mark sequences can be generated by adjusting the framing mode and sending the appropriate number of characters.

The VP-API-II supports this mechanism along with a software programmable sequencer that enables any worldwide Caller ID protocol to be supported. The complex signalling sequences are defined using the Profile Wizard, and a number of pre-defined sequences for various markets are included in the VP-API-II package.

3.9 Signaling Control

The Signaling Control blocks handle the System State and performs the related control functions such as DC feed, metering and ringing generation and line test for each channel. The System State register has a 4-bit System State field and three state modifier bits, POLNR, ACT and METR (see command [56/57h Write/Read System State, on page 78](#)). All channel specific control requires that the [4A/4Bh Write/Read Channel Enable and Operating Mode Register, on page 74](#) select the channel to be accessed.

Nine system states are possible for the Le88266/286 device: Shutdown, Disconnect, Idle, Active Low battery, Active medium Battery, Tip Open, Ring Open, Balanced Ringing and Low Gain.

3.9.1 Shutdown

Shutdown is the power-up and hardware reset state of the device. When the System State register is in Shutdown, the voice channel is deactivated (ACT = 0), the switching regulators are off, and VREF is powered down. Once the correct clocks have been programmed and the device registers initialized, the switching regulators can be enabled to generate the fixed battery voltages, and writing disconnect to [56/57h Write/Read System State, on page 78](#) places the device in the normal disconnect state from which other state transitions can occur.

3.9.2 Disconnect

In the Disconnect state, the high voltage line drivers are shut off providing a high impedance to the line. This state can be used for denial of service. VBM is the selected battery. In order to ensure smooth transition from the Disconnect state to the Idle or Active states, the following ICR (see Internal Configuration Registers on page 103) settings should be made on entering and exiting Disconnect state immediately after the system state register is written. It is recommended that all ICR register access is achieved using a read - modify - write technique to only change the specified bits.

To enable CHL VREF bias on entry to the Disconnect state:

ICR1: set the first four bits of mask byte 1, set bit 3 and clear bits 0-2 of control byte 2

ICR2: set bits 6 and 7 of mask byte 1, set bit 6 and clear bit 7 of control byte 2

To disable CHL VREF bias when exiting the Disconnect state:

ICR1: clear the first four bits of mask byte 1

ICR2: clear bits 6 and 7 of mask byte 1

Note that these special sequences are automatically handled by the VP-API-II software.

The voice channel and associated analog circuitry is normally deactivated in the Disconnect state, but can be activated and used with the converter configuration command to monitor the voltages on Tip or Ring for line diagnostics by setting the ACT bit in the system state register and making the following ICR settings.

To enable line voltage sensing via the codec transmit path in the Disconnect state:

ICR2: set bits 2 and 3 of mask byte 1 and control byte 2

ICR3: set bit 1 of mask byte 1 and control byte 2

ICR4: set bit 0 of mask byte 1 and control byte 2

To disable line voltage sensing via codec transmit path in the Disconnect state:

ICR2: clear bits 2 and 3 of mask byte 1

ICR3: clear bit 1 of mask byte 1

ICR4: clear bit 0 of mask byte 1

The converter configuration register must be written appropriately along with other codec settings to measure the selected voltage as described on page 88.

The VeriVoice™ Test Suite software implements this type of configuration to deliver a variety of diagnostic tests including foreign voltage measurement, leakage measurement, REN measurement and Receiver Off Hook (ROH) detection.

3.9.3 Low Power Idle

The Low Power Idle state is used when on hook. In this state, the DC feed is active and hook and ground key supervision functions are operating. The loop feed polarity is controlled by the POLNR bit. VBM is the selected battery and the DC feed drives tip and ring to the programmed VOC. Voice transmission is disabled to minimize power dissipation.

Even with the special configuration described under the Disconnect state, the Disconnect to Idle state transition can generate spurious off hook interrupts even into an open circuit. If the line has significant capacitance to charge, this off hook event can last a significant time. These hook events can be minimized if the state transition sequence is Disconnect to Active to Idle.

3.9.4 Active Low Battery, Active Medium Battery

The Active state is used when off hook or for on hook transmission (OHT) such as CID. In this state the DC feed is activated and voice transmission is enabled by the ACT bit. Metering signals can be generated in this state using the METR bit. The loop feed polarity is controlled by the POLNR bit. Hook and ground key supervision functions are operating.

VBM is selected if the line voltage is greater than VBL plus the programmed VAS plus ABSCAL plus $|200 * I_{Loop}|$. VBL is selected if the line voltage is less than VBL plus the programmed VAS plus ABSCAL plus $|200 * I_{Loop}|$ plus 5 V hysteresis. See [FC/FDh Write/Read DC Calibration Register, on page 104](#) for details about the auto battery switch calibration settings (ABSCAL), hysteresis voltage settings (bshv) and battery switch debounce algorithms. If the VP-API-II is not being used, which incorporates the required battery switch calibration function, the algorithm described in the application note on Battery Switch Calibration must be implemented. For correct battery switching threshold setting, both switching regulator controllers must be enabled, even if they are not being used to generate battery voltages. Ensure the ZM and YM bits are non zero after initialization.

3.9.5 Tip Open

In the Tip Open state, the Le88266/286 device provides a high impedance on the Tip lead and drives the Ring lead to the programmed VOC voltage. The loop supervision detector monitors the Ring current. When this current is larger than the programmed threshold, the HOOK bit is set which reports a ground start event. An automatic state transition to the Active state can be enabled to occur upon a ground start detection. A separate application note on VoicePort Ground Start Procedures (Document ID #081344) provides more details of the necessary call control sequences if ground start support is needed. VBM is the selected battery.

3.9.6 Ring Open

In the Ring Open state, the Le88266/286 device provides a high impedance on the Ring lead and drives the Tip lead to the programmed VOC voltage. VBM is the selected battery.

3.9.7 DC Feed

DC feed is active in the Idle, Active Low Battery, Active Medium Battery and Tip and Ring Open states. The parameters that control DC feed are summarized in [Table 7](#) and programmed in [C6/C7h Write/Read DC Feed Parameters, on page 90](#). The Idle and Active feed characteristics appear between Tip and Ring, while the feed characteristic appears from Ring to ground in the Tip Open state, and from Tip to ground in the Ring Open state. The loop current drive capability is limited in the Idle, Tip and Ring Open states, but is sufficient for off hook detection.

The DC feed parameters produce a DC feed curve at Tip and Ring as shown in [Figure](#) when the fuse resistors are inside the feedback loop formed by the RTDC, RRDC feedback network.

The VP-API-II includes recommended calibration procedures for the following parameters to meet data sheet specifications.

- The normal polarity ILA setting must be calibrated by software to meet specification.
- Normal and reverse polarity VOC must be calibrated to meet the open circuit voltage specification

In addition, the VP-API-II handles some internal configuration register programming depending on the selected VOC voltage. The basic configuration that must be applied to each channel of the device during initialization and before VOC is programmed in [C6/C7h Write/Read DC Feed Parameters, on page 90](#) is as follows:

- if $VOC \geq 51\text{ V}$
 - ICR3: clear bit 4 of mask byte 1 and set bit 6 of mask byte 3 and control byte 4
- if $VOC \leq 48\text{ V}$
 - ICR3: set bit 4 of mask byte 1, clear bit 4 of control byte 2 and clear bit 6 of mask byte 3

When VOC is programmed to 48 V or less a -30 V longitudinal clamp circuit limits the voltage on the more negative lead when VBAT is greater than $|-60\text{ V}|$. This allows for compliance to safety requirements.

When VOC is 51 V or greater, the longitudinal point will be nominally half of the applied VBM voltage.

The power supply must provide enough voltage at VBM to ensure there is overhead for the amplifiers when on hook to support on hook transmission and correct loop supervision with the programmed open circuit (VOC) voltage. This requires a mid battery of at least -57 V when VOC is calibrated to 48 V.

Parameter	Number of Bits	Range	Description
ILA	5	20 – 45 mA	Sets the current limit for DC feed
VOC	3	12 – 57 V	Sets open circuit DC feed voltage. Two ranges, 12 - 33 V and 36 - 57 V provided by VOCSFT bit
VAS	4	1.5 – 7.25 V	Allows for some programmability for the automatic battery switching point
ABSCAL	4	-5.25 – +5.25 V	Allows calibration of the battery switching point per channel
bshv	2	1.0 – 7.0 V	Battery switch hysteresis voltage

Table 7 - DC Feed and Battery Switch Programmable Parameters

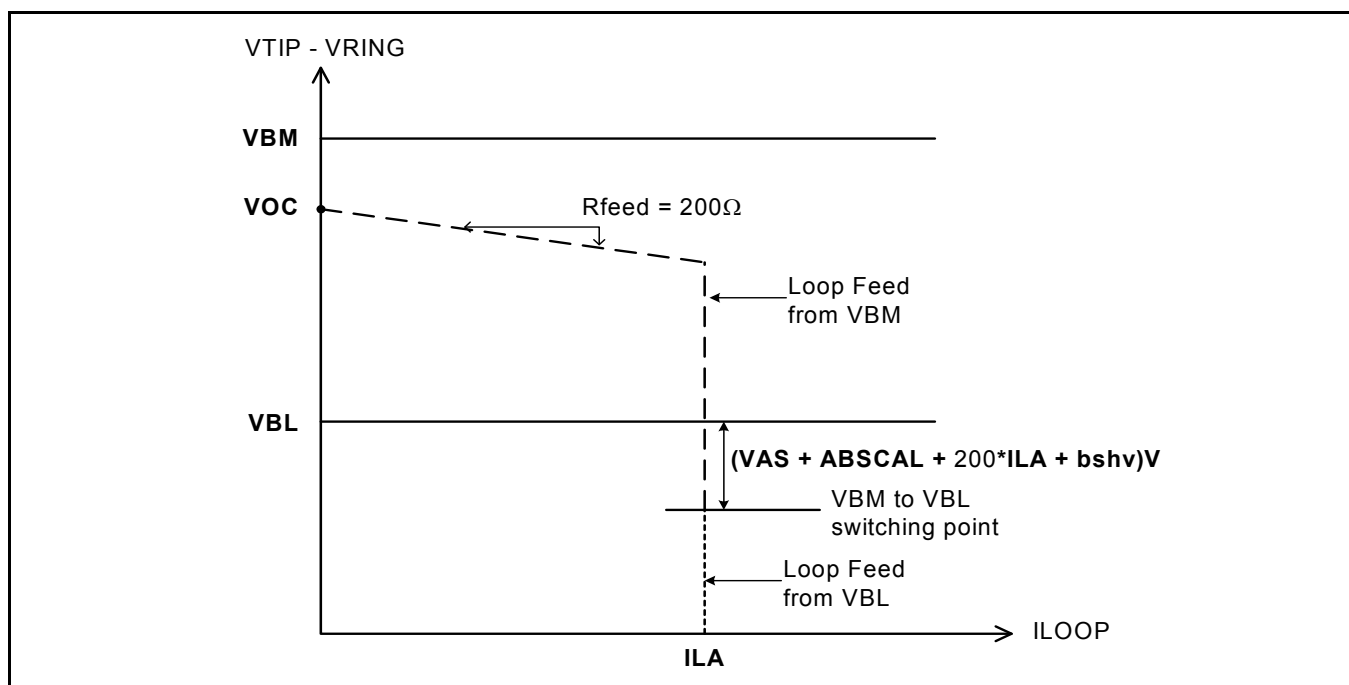

Figure 16 - Active State DC Feed I / V Characteristic

3.9.8 Metering

The Le88266/286 device is capable of 0.5 Vrms metering into a 200-Ω metering load at either 12 kHz or 16 kHz. Smooth metering application and abrupt metering application are supported. A typical metering sequence is shown in [Figure 17](#).

The duration of the metering pulses may be programmed by the user via the MTRDR parameter. This off loads much of the timing from the user’s micro controller. [Table 8](#) lists the programmable metering parameters which can be generated by Profile Wizard to help compute the maximum metering output and limit settings, which are accessed in command [D0/D1h Write/Read Metering Parameters, on page 93](#). The API-II VpStartMeter() function can then be used to send meter pulses with defined onTime and offTime which uses command [56/57h Write/Read System State, on page 78](#). Note that in a normal configuration, some of the metering current flows into the CTD and CRD EMI capacitors, so that the current sourced into an external load will be less than that programmed into the MTRSL parameter even when the metering limit voltage is not reached. The amount of metering current that flows into this load is also dependent on the total fuse resistance and the minimum load resistance, which is typically assumed to be 200 Ω.

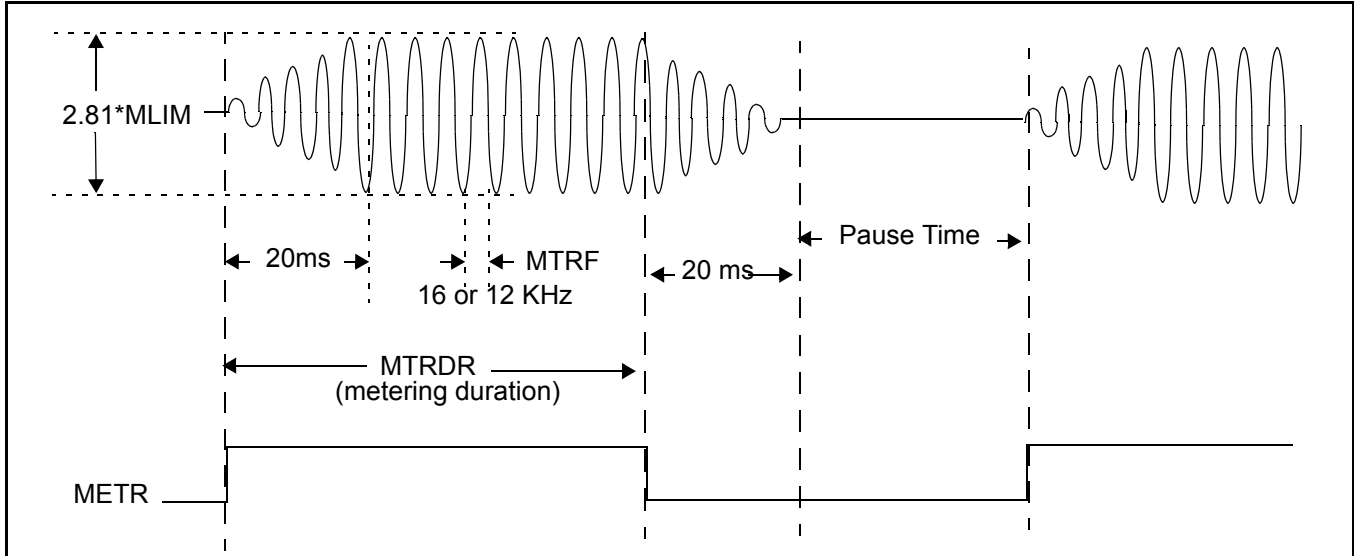

Figure 17 - Metering Pulse Definitions

Parameter	Number of Bits	Range	Description
METR	1	0, 1	"1" starts a metering pulse in the System State register.
MTRF	1	0, 1	Metering frequency. "1" is for 16 kHz. "0" is for 12 kHz (default).
MLIM	7	0 - 1.9 V 0 - 2.3 V	RMS limit voltage of 12 kHz metering signal sensed at TAC-RAC RMS limit voltage of 16 kHz metering signal sensed at TAC-RAC
SOREV	1	0, 1	Controls the ramping of the metering signal. "1" abrupt ramping. "0" smooth ramping (default).
MTRSL	7	0 - 8.636 mA	RMS output current of the ramped metering signal with TIPD-RINGD short circuit
MTRDR	8	2.5 - 637.5 ms	Metering duration. From 2.5 to 637.5 ms with step size of 2.5ms 0 produces continuous metering
MTRPK	8	0 - 1.9 V 0 - 2.3 V	Maximum RMS voltage of 12 kHz metering signal sensed at TAC-RAC Maximum RMS voltage of 16 kHz metering signal sensed at TAC-RAC

Table 8 - Metering Programmable Parameters

3.9.9 Ringing

In this state, the voice DAC is used to apply the ringing signal generated from Signal Generator A and the Bias generator to the high voltage line driver. Internal feedback maintains a low (200-Ω) system output impedance during ringing. The current limit is increased in the Ringing state and is programmable via the ILR parameter in register [C2/C3h Write/Read Loop Supervision Parameters, on page 90](#). In order to minimize line transients, entry and exit from the Ringing states are intelligently managed by the Le88266/286 device when zero cross ring entry/exit (ZXR) is enabled. When ringing is requested by the user, the signal generator is started but not applied to the subscriber line until the ringing voltage is equal to the on-hook Tip-Ring voltage. This algorithm, known as *Ring Entry*, assures that there is a smooth line transition when entering ringing. Ring entry is guaranteed to occur within one period of the programmed ringing frequency. Ring Exit is an analogous procedure whereby the ringing signal is not immediately removed from the line after a ring trip or new state request. The ringing signal will persist until its voltage is equal to the required line voltage. It is recommended that ZXR is enabled for all normal ringing operations. The Ringing state uses the VBH supply, and the peak ringing voltage that can be generated is equal to VBH - 4 V.

3.9.9.1 Balanced Ringing

Internal balanced ringing drives the subscriber line with symmetrical ringing voltage waveforms (see [Figure 18](#)). The Le88266/286 device can be programmed to output either sinusoidal or trapezoidal ringing waveforms. When using the VoicePath API-II, the

associated profile wizard allows simple configuration of desired ringing waveforms. For manual programming, see register [D2/D3h Write/Read Signal Generator A, B and Bias Parameters, on page 94](#) for setting ringing amplitude, frequency, and DC bias along with the Trapezoidal Ringing application note for more details on programming trapezoidal ringing. In the balanced ringing mode, the ringing signal is driven differentially, thus maximizing the ringing signal swing. The DC bias parameter should always be programmed as a positive value. This will normally generate a negative bias between TIP and RING, and a positive bias can be generated if the POLNR bit is set in [56/57h Write/Read System State, on page 78](#). (see [Figure 18](#)) When in the balanced ringing mode, the Le88266/286 device appears to the subscriber line as a voltage source with an output impedance of 200 Ω and is capable of 110-V peak ringing (Maximum AC plus DC ringing voltage). It is recommended that the default zero crossing entry and exit be used in all normal applications to minimize transients on ringing entry and exit.

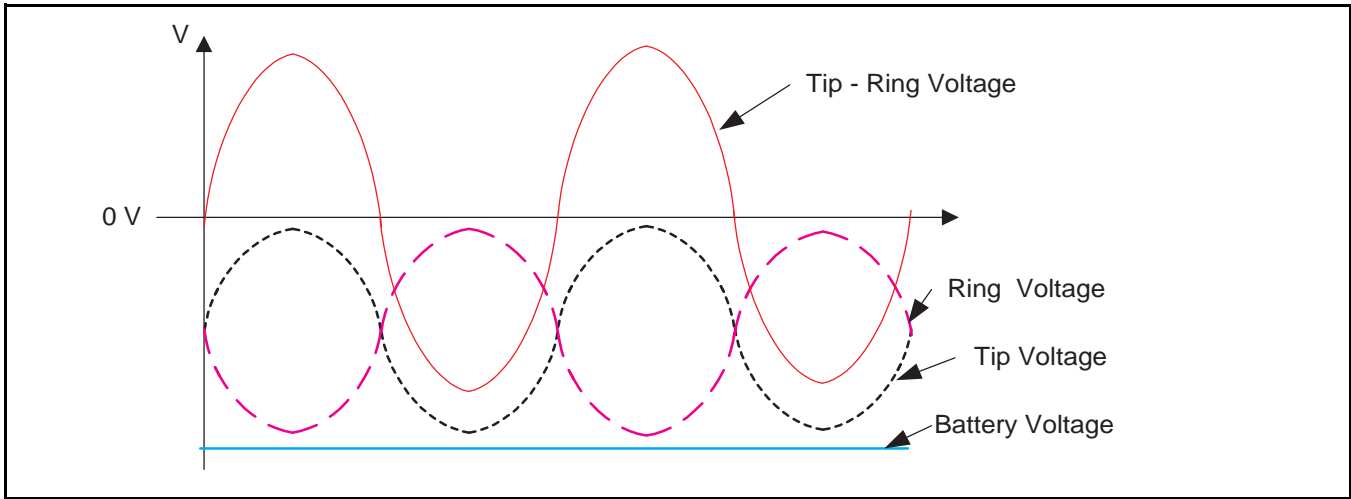

Figure 18 - Balanced Ringing with Fixed Tracking Supply

3.9.9.2 Ringing Cadencing

The on-chip cadencer is available to automate the cadencing of the ringing signal. When this feature is used, ring entry and exit are smooth when the ZXR bit in [68/69h Write/Read System State Configuration, on page 81](#) is 0. Off Hook or Ring Trip causes the device to exit the cadenced ringing state. An off hook can occur on ring exit with highly capacitive ringing loads. The system should debounce these events and ignore off hook at the end of ringing for at least 100 ms. If the off hook is not verified, ringing can continue on the same cadence by simply re-entering the ringing state. The VP-API-II takes care of these hook event masking and debounce issues.

If the system provides control for the cadence, then the system state used between ringing bursts should be the Idle (no voice transmission) or Active VBM state.

3.9.10 Low Gain

The Low Gain state reduces the gain of the internal high voltage line driver. This special mode increases the accuracy of certain line diagnostic measurements, in particular leakage tests. This is used by the VeriVoice software package to deliver line diagnostics in line with requirements described in GR-909.

3.10 Supervision Processing

The programmable supervision parameters are accessed using register [C2/C3h Write/Read Loop Supervision Parameters, on page 90](#).

3.10.1 Switch Hook Detection

The supervision circuits of the Le88266/286 device provides de-bounced off-hook indications to an external processor via the MPI for each channel. The supervision circuit compares a scaled version of the Tip-Ring current to a programmed off-hook threshold, TSH. The output of the comparator is debounced by a programmable debounce timer, DSH. The debounce time should not be

programmed less than 6 ms. A change in hook state can generate an interrupt to the user's micro-controller depending on the interrupt mask register.

In addition, if the TDIM bit in the [5E/5Fh Write/Read Device Mode Register, on page 79](#) is set, the status of the Hook bit is saved in [CFh Read Test Data Buffer, on page 92](#) at a rate defined by the DRAT field in the [A6/A7h Write/Read Converter Configuration, on page 88](#) when the Codec is activated. If information from this buffer is needed in the IDLE state, then the ACT bit in the system state register must also be set. In normal operation, this data is only accessed after an off hook event when the device is operating in an active state. Up to 6 samples are stored for each channel. If DRAT is configured for 500 Hz, the buffer will support 2 ms resolution for dial pulse measurement even with a system polling rate of only 10 ms. Use of this feature is directly supported by the VP-API-II.

3.10.2 Ground Key Detection

A separate detector is provided for ground key detection for each channel. This detector is similar to the supervision detector and monitors a scaled version of the longitudinal drive current. The scaled longitudinal drive current is compared to a ground key threshold, TGK to determine the existence of a ground key. The output of the comparator is debounced by a programmable debounce timer, DGK. The debounce time should not be programmed less than 12 ms. A change in ground key state can generate an interrupt to the user's micro-controller depending on the interrupt mask register.

Parameter	Number of Bits	Range	Description
TSH	3	8 - 15 mA	Sets the threshold for supervision detector.
DSH	5	12 - 62 ms	Sets the debounce time for the supervision detector
TGK	3	0 - 42 mA	Sets the threshold for ground key detector.
DGK	5	4 - 28 ms	Sets the debounce time for the ground key detector

Table 9 - Programmable Supervision Parameters

3.10.3 Ring Trip Detection

The ring trip detection circuit for each channel provides de-bounced ring trip indications to an external processor via the MPI. The Ring Trip circuit compares a scaled version of the Tip-Ring current to a programmed Ring Trip Threshold, RTTH. The output of the comparator is processed by the ring trip algorithm on a cycle by cycle basis to provide immunity to false ring trips and filter transients common to ringing and ring trip. In addition, more than 50% of the time near ringing current limit will generate a trip indication. A positive Ring Trip occurs if a trip indication is present for two complete ring cycles, and an interrupt can be raised to the user's micro-controller.

The device default configuration is for AC only sinusoidal ringing capable of driving 5 REN ringing loads and a 750 Ω total loop resistance. The following equations can be used to select new ring trip settings when using different ringing waveforms and different loads. They allow the ratio of the open circuit ringing voltage to the ringing threshold current to vary by +/-20%, which is conservative

Name	Description
AMPA	Amplitude of signal generator A which is used for ringing.
FREQA	Frequency of signal generator A which is used for ringing.
BIAS	DC bias for ringing.
RTDCAC	Ringing trip based on AC only or Battery Backed (DC) Ringing
RTTH	Ringing trip threshold in 0.5 mA steps from 0 to 63.5 mA
ILR	Ringing current limit programmed in 2 mA steps. ILR = 0 represents 50 mA, ILR = 31 represents 112 mA
HOOK	Interrupt in signalling register indicating a ring trip occurred.

Table 10 - Ring Trip Parameters

For AC only ringing, RTDCAC is 1 and the ringing current is half-wave rectified and averaged over a ringing cycle. If this result exceeds the RTTH threshold for two successive cycles, the HOOK bit will be set. This method limits the supported loop length

depending on the minimum must not trip ringing impedance (R_{mnt} in Ohms) and allowing for errors in the applied ringing voltage and trip level. The maximum loop resistance is given by:

$$R_{LOOP(max)} = 0.67 \cdot R_{mnt} - R_{phone} - 66 \cdot \Omega$$

$R_{LOOP(max)}$ excludes the DC resistance of the phone (R_{phone} , typically 430 Ω in the U.S.), and the fuse resistance if DC line sensing is behind the fuse resistors.

For a sinusoidal ringing waveform of V_{RING} rms volts, and R_{mnt} impedance, the following ring trip settings should be used:

$$RTTH = \frac{0.54 \cdot V_{RING}}{R_{mnt} + 200 \cdot \Omega}$$

$$ILR = \frac{1.4 \cdot V_{RING}}{R_{mnt} + 200 \cdot \Omega}$$

In general for short loop applications, it is recommended to use AC ring trip even in the presence of a DC bias that could allow a DC based ring trip, and the above equations still apply. Note that the ringing source impedance is nominally 200 Ω .

3.11 Analog Reference Circuits

The analog reference circuit generates a reference voltage and reference current for use by both channels. The reference current is generated through the external resistor R_{REF} and the external capacitor, C_{REF} , provides filtering on the reference voltage.

3.12 High Voltage Line Driver

The High Voltage Line Drivers interface to Tip/Ring and drive all DC and AC signals onto the line, including the ringing signal. The Line Drivers are capable of generating a 110 Vpk differential signal. The Line Drivers are current limited and have integrated thermal shutdown protection.

3.13 Internal Test Termination

An internal test termination is available on all devices, enabled by the API-II and used by the VeriVoice test software for a number of self tests. The internal test termination is enabled using the API-II set relay state command with option `VP_RELAY-BRIDGED_TEST`.

3.14 Test Load Switch (Le88286DLC only)

An integrated bi-directional test load switch resides in the Le88286DLC device's high voltage line driver. When connected to an external resistor, the test load switch can be used to test system functionality and to calibrate the system for diagnostic tests.

By default, the API-II will enable the tip to ring switch instead of the internal test termination on the Le88286DLC when `VP_RELAY-BRIDGED_TEST` relay state is selected.

Simple on/off test load control for each channel is provided by programming internal configuration register 1. Operation of the test load is normally executed in the Idle, Active (Normal and Reverse) or Ringing system states:

- To connect the test load between TIPD and RINGD, set bits 6 and 7 of mask byte 3, set bit 6 and clear bit 7 of control byte 4 in ICR1
- To connect the test load from the more negative of TIPD or RINGD and ground, set bits 6 and 7 of mask byte 3, clear bit 6 and set bit 7 of control byte 4 in ICR1
- To disconnect the test load, clear bits 6 and 7 of mask byte 3 in ICR1

3.15 Line Testing

The Le88264 device provides the ability for the user to perform some of the *Telcordia GR-909-CORE / TIA-1063* diagnostic testing for the voice ports. In Test mode, a variety of input signals can be read from the voice A/D converter. These signals include the switching regulator voltage and the line DC and AC voltages. Two software packages are available from Microsemi for FXS line testing:

3.15.1 VeriVoice™ Auditor

VeriVoice Auditor is a basic outward line testing package with pass / fail results. It includes the following tests:

- Line Voltage: Checks for hazardous and foreign AC and DC voltages.
- Receiver Off-Hook: Checks for longitudinal fault, off-hook resistive fault and receiver off-hook.
- Regular REN: Tests the impedance of the line and returns a fail if the Ringer Equivalence Number (REN) is too low or high.
- Resistive Fault: Measures three-element resistance.
- GR-909-CORE / TIA-1063: Performs all of the GR-909-CORE outward tests in the correct sequence.

3.15.2 VeriVoice™ Professional

VeriVoice Professional is a more advanced test suite featuring the same outward line tests as VeriVoice Auditor, but with measured results (not just pass / fail), enhanced three element REN test, and the following additional tests:

- Electronic REN: Provides REN Tip to Ring, Tip to ground and Ring to ground based on capacitance
- Capacitance: Measures three element line capacitance
- Master Socket: Detects master socket terminations
- Cross Connect: Detects cross connected FXS
- Loopback: Enables receive-to-transmit signal loopback using two different methods
- Read Loop Conditions: Samples voltages between Tip and Ring, Tip to ground, Ring to ground, and VBAT to ground. Also samples metallic and longitudinal line currents in supported states.
- Read Battery Conditions: Reads the battery voltages connected to the line circuit.
- DC Voltage Self-Test: Verifies that the line circuit has the ability to drive the voltage ranges required for the normal operation of the line circuit.
- DC Feed Self-Test: Measures the voltage and current across a known test termination using the DC feed profile that has been programmed.
- Ringing Self-Test: Verifies ring signal generation, drive capability, and ring trip.
- On/Off Hook Self Test: Creates on-hook and off-hook conditions on the line using the test termination and verifies that they are properly reported.

3.16 Switching Regulator Controllers

The switching regulator controller and the external power train circuitry provide a flexible switching regulator that produces the negative supply voltages required by the High Voltage Line Drivers to drive the line.

For the applications circuit shown in [Figure 9.1, Application Circuit, on page 66](#), Switcher Y has been configured to generate two fixed supplies, VBH/VBM and VBL where the VBL supply is regulated. By regulating VBL at the 30 VDC SWYV setting with BSI = 00b and using a transformer with an output winding split into three equal sections, VBH will be centered around 90 VDC. Refer to [Figure 44, Le88266/286 Switching Regulator Circuit, on page 67](#) for a more detailed schematic of the external components needed to implement the regulator. The regulator shown is a typical Fly-Back configuration with a multi-tap transformer configured for two outputs. A bleeder resistor from VBH to VBL should be used to pre-load the VBH supply and limit VBH when VBL is heavily loaded.

Alternatively, using a different sense resistor arrangement and setting the BSI bits in the [E4/E5h Write/Read Switching Regulator Parameters, on page 99](#) to 10b, the mid (and high) battery is the regulated output. Depending on the application, the power supplies can be sized (mainly the external transformer and filtering components) to support a number of separate devices.

The LFC pins support a soft start for the switching regulator controllers by filtering the internally generated switcher output reference using an external capacitor. LFC₁ is associated with Switcher Y, and LFC₂ is associated with Switcher Z. The pole is set with a nominal 4 k Ω internal resistance, allowing a 0.1 μ F capacitor to provide a 10 ms ramp time. It is also possible to control the power-up of the switching regulators by appropriate use of the switcher power modes, eliminating the need for external capacitors. If the switcher controller is not being used, the corresponding LFC pin can be left open.

Even if the Le88266/286 device is not using the switching regulator controllers to generate the battery supplies, it must sense each of the applied batteries through the SWVSY, SWVSZ and XB pins for correct longitudinal control and battery switching. The meaning of each pin can be controlled by the BSI bits according to [Table 11](#). This allows flexible connection options for each power supply controller to regulate one of two battery inputs, either VBL or VBM for switcher Y, or the VBH or VBM supply for switcher

Z. In addition, both switching regulator controllers must be enabled in register [E6/E7h Write/Read Switching Regulator Control, on page 100](#) for proper battery switch threshold setting.

The power up sequence following a hardware reset and clearing clock fail is to transition from Shutdown to the Disconnect state, wait at least 5 ms for Vref to settle and then enable the switching regulators.

BS11	BS10	Low Battery Sense Pin	Mid Battery Sense Pin	High Battery Sense Pin
0	0	SWY	XB	SWZ
0	1	SWY	SWZ	XB
1	0	XB	SWY	SWZ
1	1	RSVD	RSVD	RSVD

Table 11 - Battery Input Selections

4.0 Connection Diagrams and Pin Descriptions

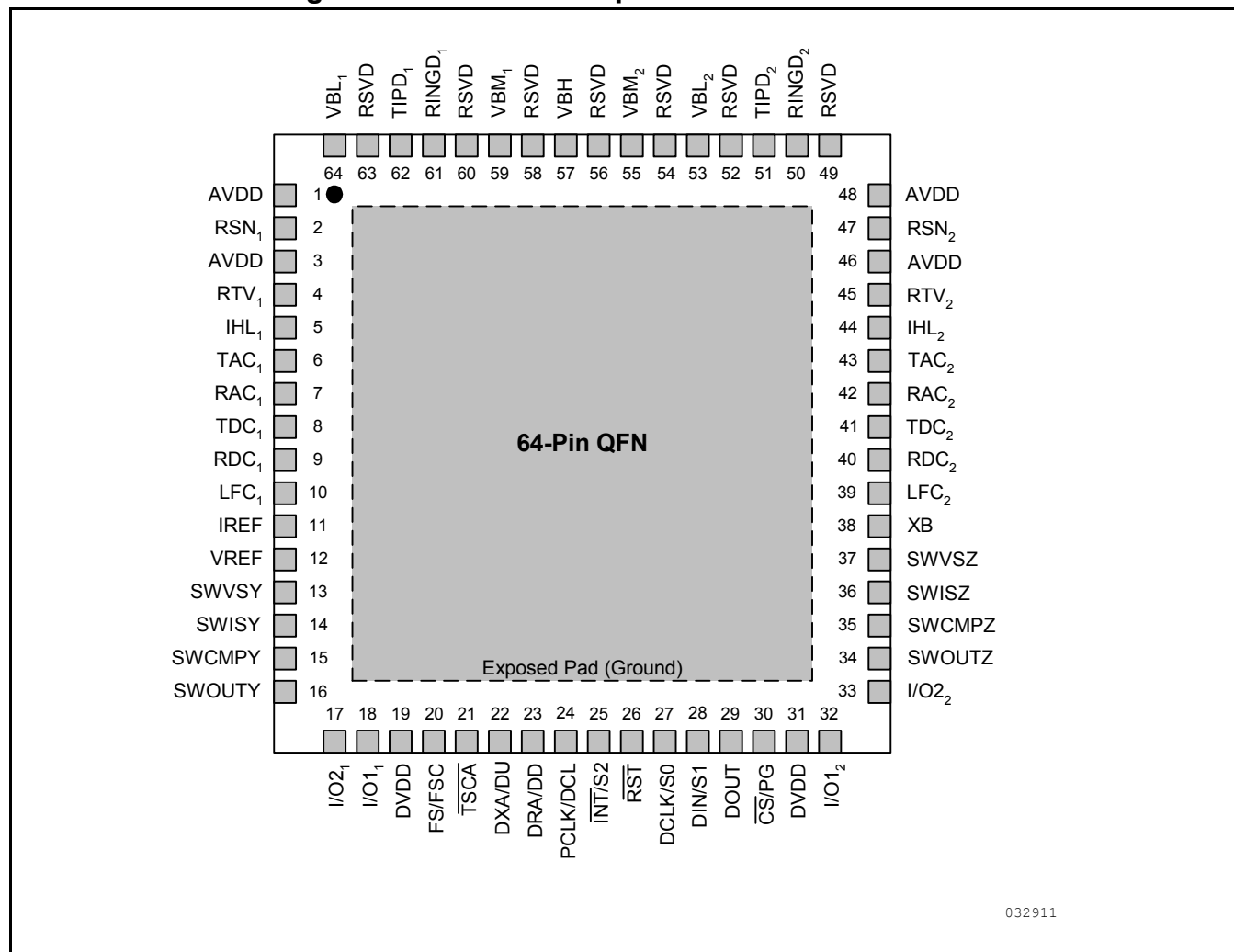

Figure 19 - Le88266/286 Device 64-Pin QFN Package (Top View)

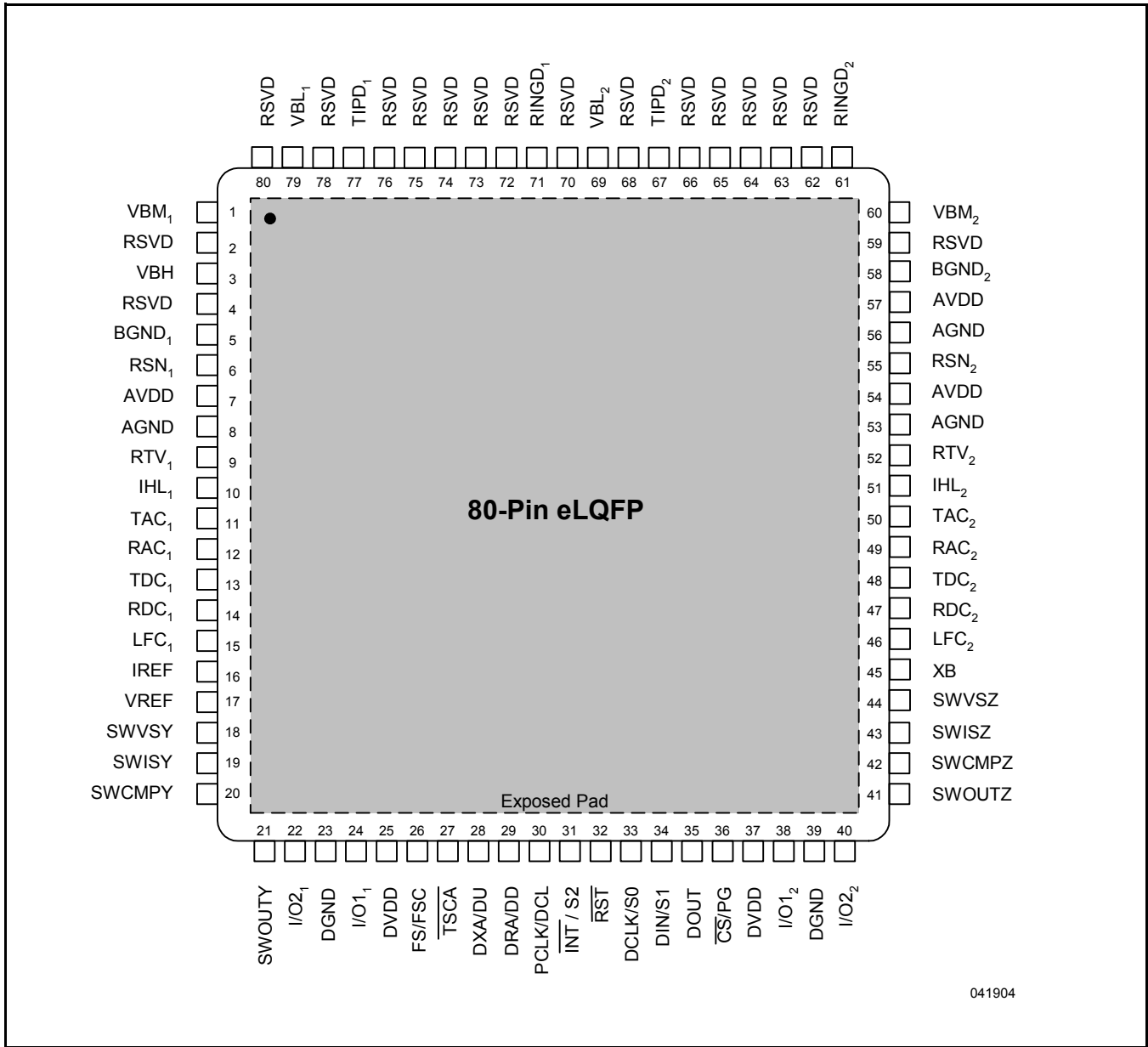
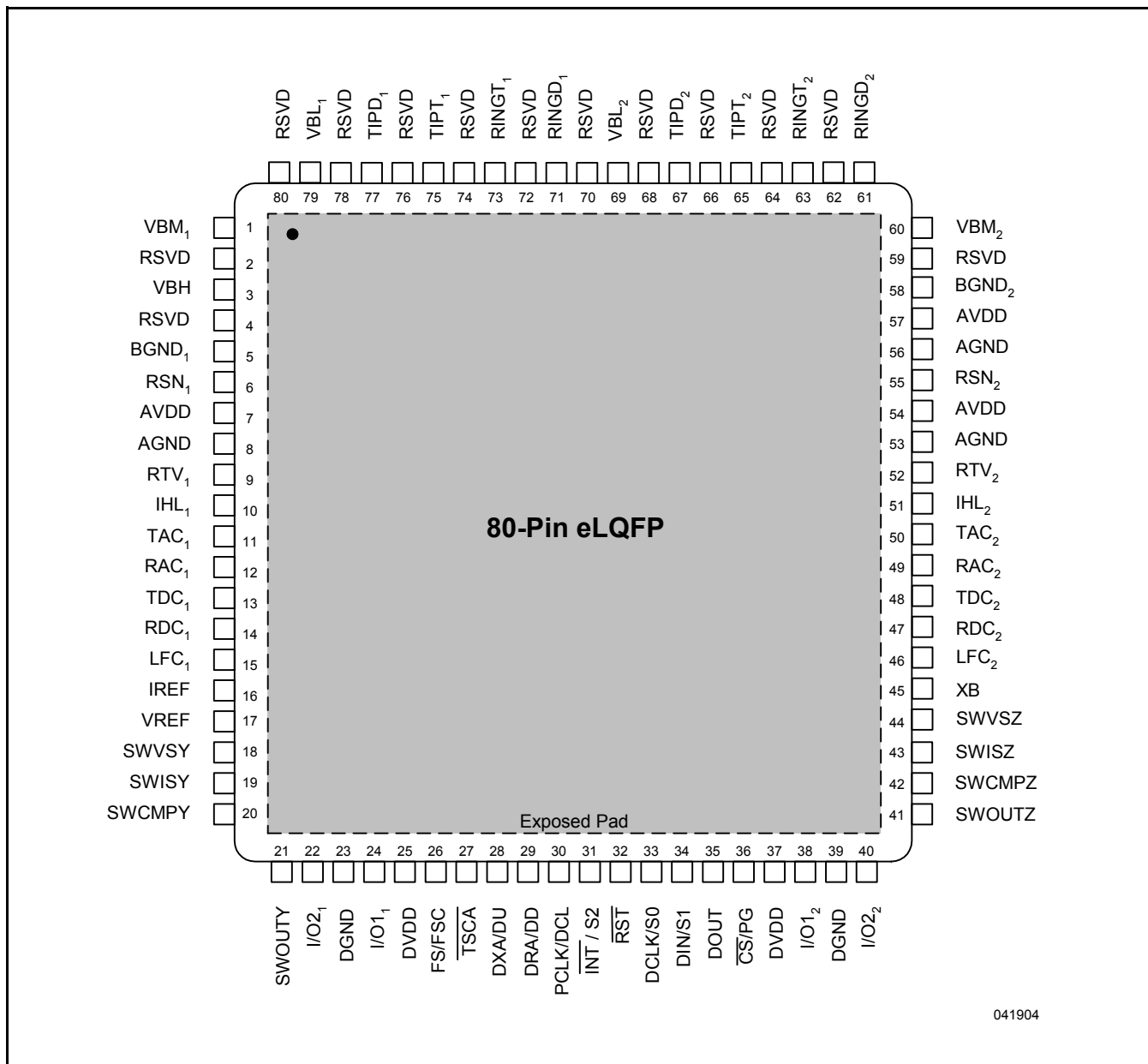

Figure 20 - Le88266 Device 80-Pin eLQFP Package (Top View)



041904

Figure 21 - Le88286 Device 80-Pin eLQFP Package (Top View)

Table 12 - Le88286DLC Device Pin Descriptions

NAME	Type	Description
AVDD/DVDD	Power	Analog and digital power supply inputs. AVDD and DVDD are provided to allow for noise isolation and proper power supply decoupling techniques. For best performance, all of the VDD power supply pins should be connected together at the power supply or power connection to the printed circuit board.
AGND/DGND	Power	Separate analog and digital grounds are provided to allow noise isolation; however, the grounds are connected inside the part, and must also be connected together on the circuit board.
BGND	Power	Battery Ground Reference.
\overline{CS}/PG	Input	<p>Chip Select/PCM-GCI. The \overline{CS}/PG input along with the DCLK/S0 input are used to determine the operating state of the programmable PCM/GCI interface. On power up, the device will initialize to GCI mode if \overline{CS}/PG is low <i>and</i> there is no toggling (no high to low or low to high transitions) of the DCLK/S0 input. The device will initialize to the PCM/MPI mode if either \overline{CS} is high <i>or</i> DCLK is toggling.</p> <p>Once the device is in PCM/MPI mode, it is ready to receive commands through its serial interface pins, DIN, DOUT and DCLK. Once a valid command has been sent through the MPI serial interface, GCI mode cannot be entered unless a hardware reset is asserted or power is removed from the part. If a valid command has not been sent since the last hardware reset or power up, then GCI mode can be re-entered (after a delay of one PCM frame) by holding \overline{CS}/PG low and keeping DCLK static. While the part is in GCI mode, \overline{CS}/PG going high or DCLK toggling will immediately place the device in PCM/MPI mode.</p> <p>In the PCM/MPI mode, the Chip Select input (active Low) enables the device so that control data can be written to or read from the part. The device coefficient registers selected by the write or read command must be enabled by writing a 1 to the EC bit in the Channel Enable Register. See the Channel Enable Register and Command 4A/4Bh for more information. If Chip Select is held Low for 16 rising edges of DCLK, a hardware reset is executed when Chip Select returns High.</p>
DCLK/S0	Input	Data Clock. In addition to providing both a data clock input and an S0 GCI address input, DCLK/S0 acts in conjunction with \overline{CS}/PG to determine the operational mode of the system interface, PCM/MPI or GCI. See \overline{CS}/PG for details. In the PCM/MPI mode, the Data Clock input shifts data into and out of the microprocessor interface of the device. The maximum clock rate is 8.192 MHz.
	Input	Packet assignment bit 0. In GCI mode, S0 is one of three inputs (S0, S1, S2) that is decoded to determine in which GCI packet the device transmits and receives data.
DIN/S1	Input	Data Input. In the PCM/MPI mode, control data is serially written into the device via the DIN pin, most significant bit first. The Data Clock determines the data rate.
	Input	Packet assignment bit 1. In GCI mode, S1 is one of three inputs (S0, S1, S2) that is decoded to determine in which GCI packet the device transmits and receives data.
DOUT	Output	Data Output. In PCM/MPI mode, control data is serially output from the device via the DOUT pin, most significant bit first. The Data Clock determines the data rate. DOUT is high impedance except when data is being transmitted, which allows DIN and DOUT to be tied together in systems which use a single line for data input and output.
DRA/DD	Input	PCM Data Receive. In PCM/MPI mode, the PCM data is serially received on the DRA port during the user-programmed time slot. Data is always received with the most significant bit first. For compressed signals, 1 byte of data is received every 125 μ s at the PCLK rate. In the Linear mode, 2 consecutive bytes of data for each channel are received every 125 μ s at the PCLK rate. In Wideband mode, the frame sync stays at 8kHz, VoicePort operates internally at 16kHz and outputs data twice per frame in evenly spaced time slots.
	Input	GCI Data Downstream. In GCI mode, the B1, B2, Monitor and SC channel data is serially received on the DD input. The device uses one of the eight GCI packets for operation. Which of the 8 GCI packets is determined by the S0, S1 and S2 inputs. Data is always received with the most significant bit first. 4 bytes of data is received every 125 μ s at the 2.048 Mbit/s data rate.
DXA/DU	Output	PCM Data Transmit. In the PCM/MPI mode, the transmit data is sent serially on the DXA port during the programmed time slot. Data is always transmitted most significant bit first. The output is available every 125 μ s and the data is shifted out in 8-bit (16-bit in Linear or PCM Signaling mode) bursts at the PCLK rate. In Wideband mode, the frame sync stays at 8kHz, VoicePort operates internally at 16kHz and outputs data twice per frame in evenly spaced time slots. DXA is high impedance between time slots, while the device is in the Inactive mode with no PCM signaling, or while the Cutoff Transmit Path bit (CTP) is on.
	Output	GCI Data Upstream. In GCI mode, the B1, B2, Monitor and SC channel data is serially transmitted on the DU output. Which GCI packet the device uses is determined by the S0, S1 and S2 inputs. Data is always transmitted with the most significant bit first. 4 bytes of data is transmitted every 125 μ s at 2.048 Mbit/s.
EPAD	Power	Exposed pad substrate connection. This pad is at ground potential and must be soldered to the PCB and connected by multiple vias to a heatsink area on the bottom of the board and to the internal ground plane.

NAME	Type	Description
FS/FSC	Input	Frame Sync. In the PCM/MPI mode, the Frame Sync (FS) pulse is an 8 kHz signal that identifies Time Slot 0 and Clock Slot 0 of a system's PCM frame. Individual time slots are referenced to this input, which must be synchronized to PCLK.
FS/FSC	Input	Frame Sync. In GCI mode, the Frame Sync (FSC) pulse is an 8 kHz signal that identifies the beginning of GCI packet 0 of a system's GCI frame. The device can access packets 0 to 7 based on the setting of the S0, S1 and S2 inputs. FSC must be synchronized to DCL.
I/O ₁ , I/O ₂	I/O	General Purpose Input/ Output (Can directly drive a 150 mW 3-V relay, external catch diode required).
I/O ₂ , I/O ₂	I/O	General Purpose Input/ Output.
IHL ₁ , IHL ₂	Output	High Level Current Drive.
$\overline{\text{INT}}$ /S2	Output	Interrupt. $\overline{\text{INT}}$ is an active Low output signal, which is programmable as either 3V CMOS-compatible or open drain. The $\overline{\text{INT}}$ output goes Low any time one of the input bits in the Signaling register changes state and is not masked in register 6C/6Dh. It also goes Low any time new transmit data appears if the ATI interrupt is armed. $\overline{\text{INT}}$ remains Low until the appropriate register is read via the microprocessor interface, or the device receives either a software or hardware reset.
	Input	Packet assignment bit 2. In GCI mode, S2 is one of three inputs (S0, S1, S2) that is decoded to determine in which GCI packet the device transmits and receives data.
IREF	Input	Current Reference. An external resistor R _{REF} connected between this pin and analog ground generates an accurate current reference used by the analog circuits on the chip.
LFC ₁ , LFC ₂	Output	Optional Component. LFC capacitor modifies the power up time. 0.1 μ F will result in about 15 ms delay. Power Up Time (s) = 240000 * (LFC Capacitor)
PCLK/DCL	Input	PCM Clock. The PCM clock determines the rate at which data is serially shifted in and out on the PCM highway and provides the clock reference for the internal PLL.
	Input	GCI Data Clock. In GCI mode, DCL is either 2.028 MHz or 4.096 MHz and an integer multiple of the FSC frequency. The internal PLL is automatically configured to run from this clock.
RAC ₁ , RAC ₂	Input	Ring lead AC sense. A series R + C network is connected from this pin to the Ring lead. The connection can be to either side of the protection resistor.
RDC ₁ , RDC ₂	Input	Ring lead DC Sense. A resistor is connected from this pin to the Ring lead. The connection can be to either side of the protection resistor.
$\overline{\text{RST}}$	Input	Device Hardware Reset. A logic Low signal at this pin resets the device to its default state.
RINGD ₁ , RINGD ₂	Output	RING-lead (B) output to the two-wire line.
RINGT ₁ , RINGT ₂	Output	RING-lead (B) test switch connection. A resistor can be connected from this pin to TIPT to implement a line test load. (Le88286DLC only).
RSN ₁ , RSN ₂	Input	High voltage line drive receive current summing node.
RSVD	Open	Reserved. Make no connection to this pin.
RTV ₁ , RTV ₂	Output	Drive output for two-wire AC impedance scaling resistor.
SWVSY, SWVSZ	Input	Voltage sense for switching regulator controller.
SWISY, SWISZ	Input	Current sense input for switching regulator controller.
SWOUTY, SWOUTZ	Output	Pulse output for gate drive to switching regulator FET.
SWCMPY, SWCMPZ	Output	Compensation connection for switching regulator controller.
TAC ₁ , TAC ₂	Input	Tip lead AC Sense. A series R + C network is connected from this pin to the Tip lead. The connection can be to either side of the protection resistor.
TDC ₁ , TDC ₂	Input	Tip lead DC Sense. A resistor is connected from this pin to the Tip lead. The connection can be to either side of the protection resistor.
TIPD ₁ , TIPD ₂	Output	TIP-lead (A) output to two-wire line.
TIPT ₁ , TIPT ₂	Output	TIP-lead (A) Test Switch Connection. A resistor can be connected from this pin to RINGT to implement a line test load. (Le88286DLC only).
$\overline{\text{TSCA}}$	Output	Time Slot Control. The Time Slot Control output is open-drain (requiring a pull-up resistor to DVDD) and is normally inactive (high impedance). In PCM/MPI mode, $\overline{\text{TSCA}}$ is active (low) when PCM data is transmitted on the DXA pin. In GCI mode, $\overline{\text{TSCA}}$ is active (low) during the GCI packet selected by S0, S1 and S2.
VBH	Supply	High (Ringing) Battery supply, and bias voltage for the high voltage line driver.
VBM ₁ , VBM ₂	Supply	Medium (On Hook) Battery supply.
VBL ₁ , VBL ₂	Supply	Low (Off Hook) Battery Supply.

NAME	Type	Description
VREF	Output	Analog Voltage Reference. The VREF output is provided in order for an external capacitor to be connected from VREF to ground, filtering noise present on the internal voltage reference. VREF is buffered before it is used by internal circuitry. The voltage on VREF is specified in DC Characteristics, on page 43 .
XB	Input	External Battery Voltage Sense.

5.0 Absolute Maximum Ratings

Stresses above those listed under *Absolute Maximum Ratings* can cause permanent device failure. Functionality at or above these limits is not implied. Exposure to absolute maximum ratings for extended periods may affect device reliability.

Storage Temperature	-55° C < T _A < +125° C
Ambient Temperature, under Bias	-40° C < T _A < +85° C
Ambient relative humidity (non condensing)	5 to 95 %
VBH, VBM _i , VBL _i with respect to BGND for Le88266 device for Le88286 device	-105 V to +0.4 V -125 V to +0.4 V
VBH, VBM _i with respect to BGND Both Lines Active VBL, VBL _i < -50 V for Le88266 device for Le88286 device	-125 V to +0.4 V -160 V to +0.4 V
VBH with respect to VBM	> VBM + 1 V
VBH with respect to VBL	> VBL + 1 V
BGND with respect to AGND	-0.4 V to +0.4 V
TIPD, RINGD to BGND: Continuous 10 ms (F = 0.1 Hz) 1 μs (F = 0.1 Hz) 250 ns (F = 0.1 Hz)	V _{BH} -1 V to BGND +1 V V _{BH} -5 V to BGND +5 V V _{BH} -10 V to BGND +10 V V _{BH} -15 V to BGND +15 V
Current from TIPD or RINGD	±150 mA
AVDD with respect to AGND	-0.4 V to + 4.0 V
AVDD with respect to DVDD	-0.4 V to + 4.0 V
DVDD with respect to DGND	-0.4 V to + 4.0 V
AGND with respect to DGND	-0.05 V to + 0.05 V
Digital pins with respect to DGND	-0.4 V to the smaller of +4.0 V or DVDD + 0.4 V
I/O ₁ current sink to DGND	70 mA
Latch up immunity (any pin)	± 100 mA
Maximum power dissipation, Continuous ¹ T _A = 85° C, 64-pin QFN P _D T _A = 85° C, 80-pin eLQFP P _D	2.5 W 3.7 W
Junction-to-ambient thermal resistance ^{2,1} In 64-pin QFN package In 80-pin eLQFP package	θ _{JA} 24° C/W 16° C/W
Junction-to-board thermal resistance ² In 64-pin QFN package In 80-pin eLQFP package	θ _{JB} 5.1° C/W 8.3° C/W
Junction-to-case (top) thermal resistance ² In 64-pin QFN package In 80-pin eLQFP package	θ _{JC(top)} 10° C/W 9° C/W
Junction-to-case (bottom) thermal resistance ² In 64-pin QFN package In 80-pin eLQFP package	θ _{JC(bottom)} 0.8° C/W 0.8° C/W
Junction-to-top characterization parameter ² In 64-pin QFN package In 80-pin eLQFP package	ψ _{JT} 5.7° C/W 6.3° C/W
ESD Immunity (Human Body Model)	JESD22 Class 1C compliant

Notes:

1. Maximum power dissipation is a function of T_{J(max)}, θ_{JA}, and T_A. The maximum allowable power dissipation at any allowable ambient temperature is P_D = (T_{J(max)} - T_A)/θ_{JA}. This figure may not be achieved due to internal thermal shutdown (see 5.1, "Thermal Resistance" on page 41)
2. These values are simulated per JESD51-7 for High Effective thermal conductivity test board with natural convection.

5.1 Thermal Resistance

The thermal performance of a thermally enhanced package is assured through optimized printed circuit board layout. Specified performance requires that the exposed thermal pad be soldered to an equally sized exposed copper surface, which, in turn, conducts heat through multiple vias to a large internal copper plane. Thermal performance depends on the number of PCB layers and the size of the copper area. Thermal measurements are performed according to JEDEC JESD51. Continuous operation above 145° C junction temperature may degrade device reliability. Thermal limiting circuitry on each channel of the Le88266/286 chip will shut down the channel at a junction temperature of about 165° C.

5.2 Package Assembly

The 'green' package devices are assembled with enhanced, environmental and compatible lead (Pb), halogen, and antimony-free materials. The leads possess a matte-tin plating which is compatible with conventional board assembly processes or newer Pb-free board assembly processes. The peak soldering temperature should not exceed 260° C during printed circuit board assembly.

Refer to IPC/JEDEC J-STD-020 for the recommended solder reflow temperature profile.

6.0 Operating Ranges

Microsemi guarantees the performance of this device over commercial (0° C to 70° C) and industrial (-40° C to 85° C) temperature ranges by conducting electrical characterization over each range and by conducting a production test with single insertion coupled to periodic sampling. These characterization and test procedures comply with the *Telcordia GR-357-CORE Generic Requirements for Assuring the Reliability of Components Used in Telecommunications Equipment*.

6.1 Recommended Operating Conditions

Analog Supply AVDD	+3.3 V ± 5 % DVDD ± 50 mV
Digital Supply DVDD	+3.3 V ± 5 %
VBH, Both lines Active VBL, $VBL_i < -50 $ V for Le88266 device for Le88286 device	-120 V to -(VOC + 7) V -150 V to -(VOC + 7) V
VBH, All other states for Le88266 device for Le88286 device	-99 V to -(VOC + 7) V -120 V to -(VOC + 7) V
VBM _i	VBH to -(VOC + 7) V
VBL _i	VBH to -20 V
DGND	0 V
AGND with respect to DGND	±10 mV
BGND with respect to AGND/DGND	±100 mV
Voltage Reference Capacitor: VREF to AGND	10 μF ± 20 %
Current Reference Resistor: IREF to AGND	75 kΩ ± 1 %
Digital Pins	DGND to 3.465 V
Analog Pins	AGND – 0.3 V to AVDD + 0.3 V

Notes: VOC is the calibrated open circuit line voltage as defined in [DC Feed, on page 27](#).

7.0 Electrical Characteristics

7.1 Test Conditions

Unless otherwise noted, test conditions are:

- Typical values are for TA = 25° C and nominal supply voltages. Minimum and maximum values are over the temperature and supply voltage ranges shown in Operating Ranges, except where noted
- Default (unity) gain in X, R, DRL, AX and AR blocks
- Default coefficients in DISN, Z and B filters
- VBH = VBM = -90 V, VBL = -30 V for Le88266 device
- VBH = -120 V, VBM = -57 V, VBL = -35 V for Le88286 device
- Fuse resistors for device tests are $R_F = 0 \Omega$
- DC feed and battery switch programmed and calibrated to ILA = 26 mA, VOC = 48.0 V, VAS = 3V, bshv = 5 V
- AC and DC load resistance $R_L = 600 \Omega$
- 0 dBm0 = 0 dBm (600 Ω) = 0.7746 Vrms. Digital gains GX0 and GR0 to achieve 0 dBr relative levels are GX0 = +6.797 dB (7A20h) A-law or linear and GX0 = +6.737 dB (2A20h) μ -Law to set A/D transmit gain to 0dB GR0 = -1.793 dB (6AA0h) A-law or linear and GR0 = -1.720 dB (3AA0h) μ -Law to set D/A receive gain to 0dB
- Ringing Tests have two conditions: C1 for Le88286 and C2 for Le88266 both with ILR = 78 mA and RTTH = 25.5 mA AC
 - C1 programmed ringing 110 V_{PK} (78.5 Vrms), 0 V_{DC} offset and 1386 Ω + 40- μ F load (5 REN)
 - C2 programmed ringing 80 V_{PK} (57 Vrms), 0 V_{DC} offset and 1386 Ω in series with 40- μ F load (5 REN)

7.2 Supply Currents and Power Dissipation

- Supply currents and power consumption are per channel of the device based on both channels in the same state
- Device or package power does not include power delivered to the load

Le88266 Operational State	Condition	I_{DD} mA (Note 2.)	$I_{VBH} + I_{VBM}$ mA	I_{VBL} mA	Package Power mW	Note
		Typ	Typ	Typ	Typ	
Shutdown	Disconnect, Battery Supplies off	4.5	0	0	15	1.
Disconnect	V_{BH}, V_{BM}	7	0.05	0.05	30	1.
Idle	V_{BH}, V_{BM} , On-Hook	14	0.85	0.05	125	1.
Active (Normal or Polarity Reversal)	V_{BH}, V_{BM} , On-Hook Transmission	23	2.05	0.05	260	1.
	V_{BL} , 600 Ω	23	0.05	27.6	500	1.
Ringing	V_{BH} , C2	28	35.0	0.05	1500	1.3.

Le88286 Operational State	Condition	I_{DD} mA (Note 2.)	I_{VBH} mA	I_{VBM} mA	I_{VBL} mA	Package Power mW	Note
		Typ	Typ	Typ	Typ	Typ	
Shutdown	Disconnect, Battery Supplies off	4.5	0	0	0	15	1.
Disconnect	V_{BM}	7	0.05	0.05	0.05	30	1.
Idle	V_{BM} , On-Hook	14	0.05	0.8	0.05	95	1.
Active (Normal or Polarity Reversal)	V_{BM} , On-Hook Transmission	23	0.05	2.0	0.05	195	1.
	V_{BL} , 600 Ω	23	0.05	0.05	27.6	650	1.
Ringing	V_{BH} , C1	28	48.0	0.05	0.05	2500	1.3.

Notes:

1. Not Tested in Production. Parameter is guaranteed by characterization or correlation to other tests.
2. I_{DD} supply current is the sum of I_{AVDD} and I_{DVDD} for the device in normal mode divided by 2. Wideband mode increases I_{DD} by 5 mA per channel.
3. Ringing signal must be cadenced to produce an average power that can be handled by the package.

7.3 DC Characteristics

Symbol	Parameter Descriptions	Min	Typ	Max	Unit	Note
V_{IL}	Digital Input Low voltage			0.8	V	
V_{IH}	Digital Input High voltage	2.0				
I_{IL}	Digital Input leakage current	-7		+7	μA	
I_{AIL}	Analog input leakage current	-1		+1		
V_{HYS}	Digital Input hysteresis	0.16	0.25	0.34	V	1.
V_{OL}	Digital Output Low voltage			0.8	V	2.
	I/O1 ($I_{OL} = 50 \text{ mA}$)			0.4		
	I/O2 and SWOUTx ($I_{OL} = 4 \text{ mA}$)			0.8		
	I/O2 and SWOUTx ($I_{OL} = 8 \text{ mA}$)			0.4		
	TSCA ($I_{OL} = 14 \text{ mA}$)			0.4		
Other digital outputs ($I_{OL} = 2 \text{ mA}$)			0.4			
V_{OH}	Digital Output High voltage					2.
	I/O1, I/O2 and SWOUTx ($I_{OH} = 4 \text{ mA}$)	$V_{DVDD} - 0.4 \text{ V}$				
	I/O1, I/O2 and SWOUTx ($I_{OH} = 8 \text{ mA}$) Other digital outputs ($I_{OH} = 400 \mu\text{A}$)	$V_{DVDD} - 0.8 \text{ V}$ 2.4				
I_{OL}	Digital Output leakage current (Hi-Z state) $0 < V < DVDD$	-7		+7	μA	
V_{REF}	VREF output open circuit voltage ($I_{VREF} = \pm 100 \mu\text{A}$)	1.43	1.5	1.57	V	
C_{IREF}	IREF pin maximum load capacitance			20	pF	1.
C_I	Digital Input capacitance			4		1.
C_O	Digital Output capacitance			4		1.
PSRR ₁	AVDD, DVDD Power supply rejection ratio (1.02 kHz, 100 mV _{RMS} , either path, GX = GR = 0 dB)	32	38		dB	
PSRR ₂	VBH, VBM _i , VBL _i Power supply rejection ratio (1.02 kHz, 100 mV _{RMS} , either path, GX = GR = 0 dB)	40				

Notes:

1. This parameter is guaranteed by characterization or correlation to other tests. Not tested in production.
2. The I/O1, I/O2 and SWOUTx outputs are resistive for less than a 0.8 V drop. Total DC current must not exceed absolute maximum ratings.

7.4 DC Feed and Signaling

Description	Test Conditions	Min	Typ	Max	Unit	Note
ILA programmable range, Active state		20		45	mA	1
I_L , Loop-current accuracy, Active state	I_L in constant-current region after ILA calibration	-10		+10	%	1
I_{RINGD} , RINGD leakage, Ring Open state	$R_L = 0$ to GND or VBM			1000	μ A	
I_{TIPD} , TIPD leakage, Tip Open state	$R_L = 0$ to GND or VBM			1000	μ A	
TIPD, RINGD leakage, Disconnect state	$R_L = 0$ to GND or VBM			10	μ A	
I_{RINGD} , RINGD current accuracy, Tip Open state	RINGD to ground	-10		+10	%	1
V_{TIPD} , ground-start signaling	TIPD to -48 V = 7 k Ω , RINGD to ground = 100 Ω	-7.5	-5		V	1,2
TDC, RDC input offset current		3.3	3.7	4.1	μ A	1,3
Ground key accuracy		-1 mA - 15%		+1 mA +15%		1
Switch hook accuracy		-20		+20	%	1
Open circuit voltage, $V_{TIPD} - V_{RINGD}$	VOC = 48 V, after VOC calibration	-8		+8		1
V_{RINGD} , open circuit	VOC = 48 V, after VOC calibration	-56.5		-49.0	V	1,2
VBM switch to VBL loop resistance	VBL = -30 V		650		Ω	4
VBL switch to VBM loop resistance	VBL = -30 V		800			4

Notes:

1. This parameter is guaranteed by characterization or correlation to other tests. Not tested in production.
2. To meet this specification when responding to a ground start, bit 7 of mask byte 3 must be set, and bit 7 of control byte 4 reset in the Normal Active state. i.e. ICR3 (F2/F3h) 00 00 80 00.
3. Analog input pad leakage can add to this value - see specification under [DC Characteristics](#).
4. Assumes battery switch calibration procedure has been executed.

7.5 Test Load Switch (Le88286DLC Device Only)

Description	Test Conditions	Min	Typ	Max	Unit	Note
Voltage Drop	$I_{switch} = 18\text{mA}$		2.6		V	1
On Resistance	$(V_{(26\text{mA})} - V_{(18\text{mA})}) / 8\text{mA}$		15		Ω	1
Off Leakage				5	μ A	

7.6 Metering

Description	Test Conditions	Min	Typ	Max	Unit	Note
Level accuracy	0.5 Vrms, 12 or 16 kHz 200 or 3000 Ω AC load	-5		+10	%	1
Frequency accuracy	12 or 16 kHz	-0.1		+0.1	%	1

Notes:

1. This parameter is guaranteed by characterization or correlation to other tests. Typical values not tested in production.

7.7 Ringing

Description	Test Conditions	Min	Typ	Max	Unit	Note
Ringing Voltage Accuracy	Case C1 or C2	-5		+10	%	1.
Ringing DC offset, $V_{TIPD} - V_{RINGD}$	$R_L = \text{open circuit}$, Programmed RInging = 0 Vpk	-3	+1	+5	V	1.
Harmonic distortion	Case C1 or C2		3	5	%	1.
Ringing current limit accuracy	$R_L = 300 \Omega$	-10		10	%	1.
Ringing source impedance			200		Ω	1.
AC ring trip accuracy	EGBIAS = 0	-15		+15	%	2.
Ring trip delay	Periods of ringing	1		3	cycles	1.

Notes:

- This parameter is guaranteed by characterization or correlation to other tests. Not tested in production.*
- If the ringing current in the loop is near the current limit more than 50% of the time, a ring trip will occur regardless of the average current.*

7.8 Switching Regulator Controller

The following specifications apply to switching regulator controllers Y and Z.

Description	Test Conditions	Min	Typ	Max	Unit	Note
SWISx shutdown threshold	Referenced to AGND	85	100	115	mV	
SWISx hysteresis			5		mV	1.
SWISx input bias current		-10		10	μA	1.
SWISx shutdown delay	$V_{SWISx} > 115\text{mV}$	12		88	ns	2.
SWCPMx output current		-200		200	μA	1.
SWCMPx operating range		0.4		2.6	V	1.
SWVSx to SWCMPx gain		0.4		40	V/nA	1.
SWVSx to SWCMPx bandwidth		100			kHz	1.
SWVSx input offset current		3.3	3.7	4.1	μA	3.
LFC output impedance			80		k Ω	1.
SWxV output voltage accuracy	Calibrated -30 V Voltage	-33		-27	V	1. , 4.

Notes:

- This parameter is guaranteed by characterization or correlation to other tests. Not tested in production.*
- Time from SWISx exceeding threshold to SWOUTx voltage passing through $V_{DD}/2$.*
- Analog input pad leakage can add to this value - see specification under [DC Characteristics](#)*
- Accuracy following battery calibration depends on the battery voltage sense accuracy (+/-4 %) plus the calibration resolution of +/- 0.625 V*

7.9 Converter Configuration Signal Sense Accuracy

See command [A6/A7h Write/Read Converter Configuration, on page 88](#) for measurement ranges and resolution.

Description	Test Conditions	Min	Typ	Max	Unit	Note
Metallic AC coupled voltage	Converter Configuration = 00h	-4		+4	%	
Battery input at SWVSY	Converter Configuration = 01h	-3.0 V -4 %		+3.0 V +4 %	V	1,3
Battery input at SWVSZ	Converter Configuration = 02h	-3.0 V -4 %		+3.0 V +4 %	V	
Battery input at XB	Converter Configuration = 03h	-3.0 V -4.7 %		+3.0 V +3.3 %	V	
Tip voltage to ground	Converter Configuration = 04h	-6 %		+6 %	V	1,2,3
Ring voltage to ground	Converter Configuration = 05h	-6 %		+6 %	V	
Metallic DC line voltage	Converter Configuration = 06h	-7 %		+7 %	V	
Metallic loop current	Converter Configuration = 07h	-1.5 mA -5 %		1.5 mA +5 %	mA	1,3
Total longitudinal current	Converter Configuration = 08h	-2.5 mA -5 %		2.5 mA +5 %	mA	1,4
Voice DAC (Full loopback)	Converter Configuration = 0Ah	-1.0		+1.0	dB	
Tip Voltage to Longitudinal Current Ratio	Ratio of Voltage to current in Low Gain state, two point measurement	-6.5		+6.5	%	3
Ring Voltage to Longitudinal Current Ratio		-6.5		+6.5	%	
Metallic Voltage to Metallic Current Ratio		-6.5		+6.5	%	

Notes:

1. The % limits are defined as the % of programmed threshold value or the % of the actual voltage or current on Tip / Ring
The offset and percentage errors are independent and combine as rms errors.
2. This is measured in production by calibrating offset voltage using the [FC/FDh Write/Read DC Calibration Register](#) and applying -26V for voltage to ground and 20 V metallic. Accurately measuring smaller voltage requires care in offset calibration.
3. For DC measurements these limits require that the high pass filters are disabled in the operating conditions register and the residual A/D offset is removed by reading the no connect value (Converter Configuration 0Bh) and subtracting it from the measured value. DISN should be cut off (00h), the analog Voice Path Gains set to unity (00h) and the operating functions register set to linear mode (80h).
4. For DC measurements these limits require that the high pass filters are disabled in the operating conditions register, DISN should be cut off (00h), the analog Voice Path Gains set to unity (00h) and the operating functions register set to linear mode (80h).

7.10 Transmission Characteristics - Narrowband Codec Mode

Description	Test Conditions	Min	Typ	Max	Unit	Note
TAC - RAC overload level	Active state, GX = AX = 0 dB	3.4			Vpk	1,2
Transmit level, A/D	0 dBm, GX = GX0, 1014 Hz		0		dBm0	
Receive level, D/A	0 dBm0, GR = GR0, 1014 Hz		0		dBm	
Gain accuracy, D/A or A/D	0 dBm0, 1014 Hz, off-hook	-0.35		+0.35	dB	
Gain accuracy, D/A or A/D	0 dBm0, 1014 Hz, on-hook	-0.75		+0.25	dB	
Idle channel noise V _{TIPD} - V _{RINGD} DXA, Digital out	DRA, Digital input = 0 A-law, 0 dB DRA, Digital input = 0 μ-law, 0 dB V _{TIPD} - V _{RINGD} = 0 VAC A-law, 0 dB V _{TIPD} - V _{RINGD} = 0 VAC μ-law, 0 dB			-74 16 -65 19	dBm0p dBmC0 dBm0p dBmC0	5 , 1 , 5 , 5 , 1 , 5
Two-wire return loss	200 to 3400 Hz	26			dB	1
Longitudinal to Metallic balance TIPD - RINGD or DXA	200 to 3400 Hz	50			dB	7
DRA to Longitudinal signal generation	300 to 3400 Hz	42				7
Longitudinal current capability, TIPD or RINGD	Active state	8.5			mArms	1
Longitudinal impedance at TIPD or RINGD	0 to 100 Hz, LI = 0		100		Ω/pin	1
Crosstalk between channels TX or RX to TX RX or TX to RX	0 dBm0, 1014Hz, Average 0 dBm0, 1014Hz, Average			-76 -78	dBm0	1
Attenuation distortion	300 to 3000 Hz	-0.125		+0.125	dB	1,3
Single frequency distortion				-46		4
Second harmonic distortion, D-A	GR = 0 dB, linear mode			-55		
End-to-end absolute group delay	B = Z = 0; X = R = 1, C/L = 0			678	μs	1,6

Notes:

- This parameter is guaranteed by characterization or correlation to other tests. Not tested in production.*
- Overload level is defined when THD = 1%.*
- See [Figure 22](#) and [Figure 23](#).*
- 0 dBm0 input signal, 300 to 3400 Hz measurement at any other frequency, 300 Hz to 3400 Hz.*
- No single frequency component in the range above 3800 Hz may exceed a level of -55 dBm0.*
- The End-to-End Group Delay is the absolute group delay of the echo path with the B filter turned off.*
- This parameter is tested at 1 kHz in production. Performance at other frequencies is guaranteed by characterization.*

7.11 Attenuation Distortion - Narrowband Codec Mode

The signal attenuation in either path is nominally independent of the frequency. The deviations from nominal attenuation will stay within the limits shown in [Figure 22](#) and [Figure 23](#). The reference frequency is 1014 Hz and the signal level is -10 dBm0.

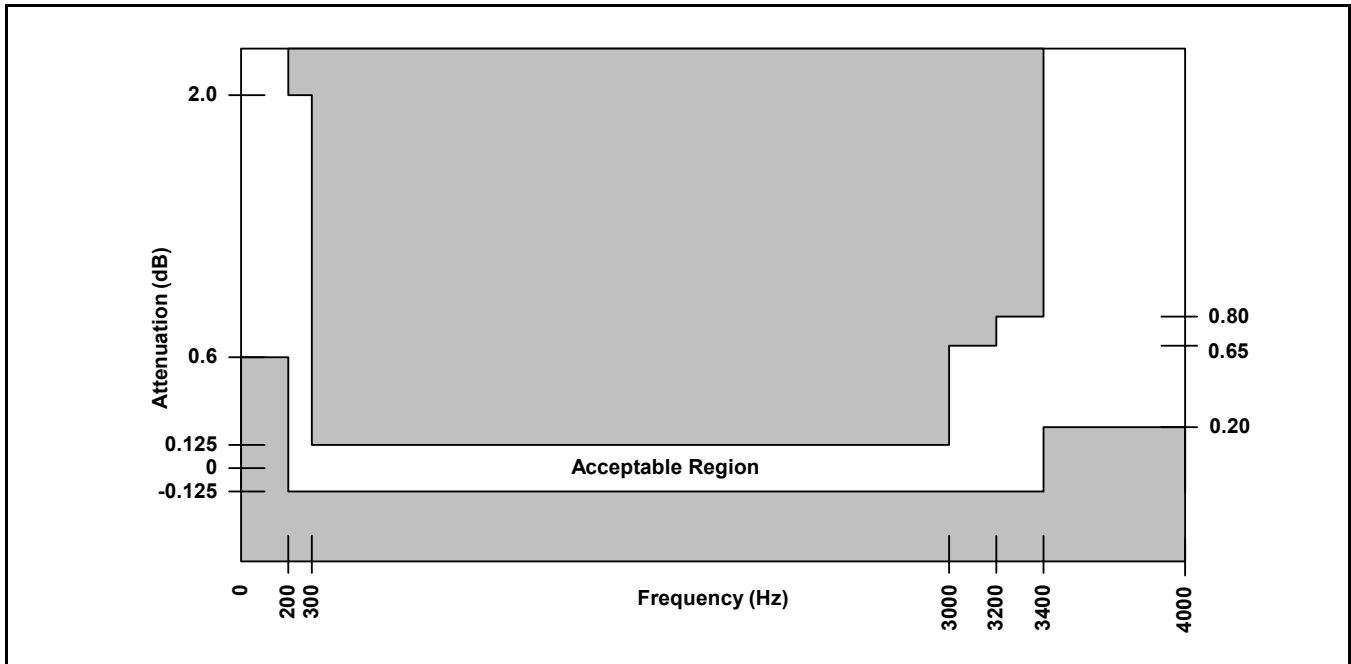

Figure 22 - Transmit Path Attenuation vs. Frequency

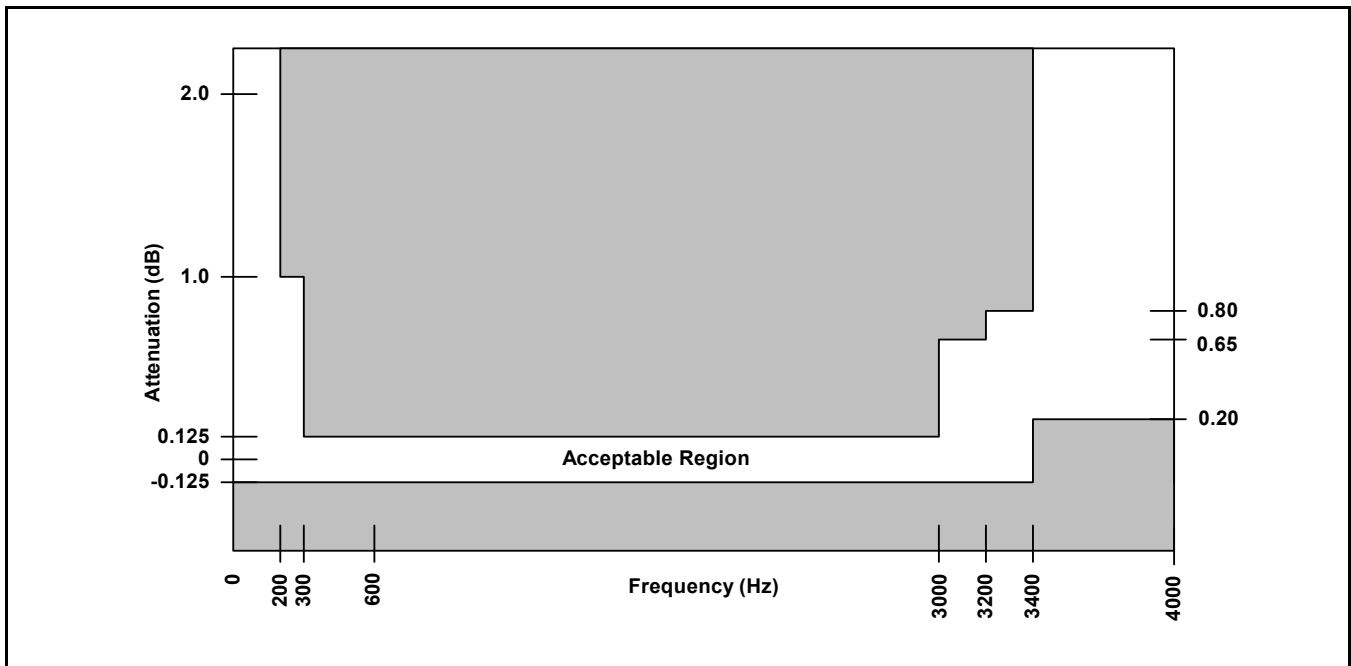

Figure 23 - Receive Path Attenuation vs. Frequency

7.12 Discrimination Against Out-of-Band Input Signals - Narrowband Codec Mode

When an Out-of-Band sine wave signal of frequency f , and level A is applied to the analog input, there may be frequency components below 4 kHz at the digital output which are caused by the Out-of-Band signal. These components are at least the specified dB level below the level of a signal at the same output originating from a 1014-Hz sine wave signal with a level of A dBm0 also applied to the analog input. The minimum specifications are shown in [Table 13](#).

Notes: The attenuation of the waveform below amplitude A , between 3400 Hz and 4600 Hz, is given by the formula:

$$\text{Attenuation} = \left[14 - 14 \sin\left(\frac{\pi(4000 - f)}{1200}\right) \right] \text{ dB}$$

Frequency of Out-of-Band Signal	Amplitude of Out-of-Band Signal	Level below A
16.6 Hz < f < 45 Hz	-25 dBm0 < $A \leq 0$ dBm0	18 dB
45 Hz < f < 65 Hz	-25 dBm0 < $A \leq 0$ dBm0	25 dB
65 Hz < f < 100 Hz	-25 dBm0 < $A \leq 0$ dBm0	10 dB
3400 Hz < f < 4600 Hz	-25 dBm0 < $A \leq 0$ dBm0	see Figure 24
4600 Hz < f < 100 kHz	-25 dBm0 < $A \leq 0$ dBm0	32 dB

Table 13 - Out of Band Discrimination, Narrowband Codec Mode

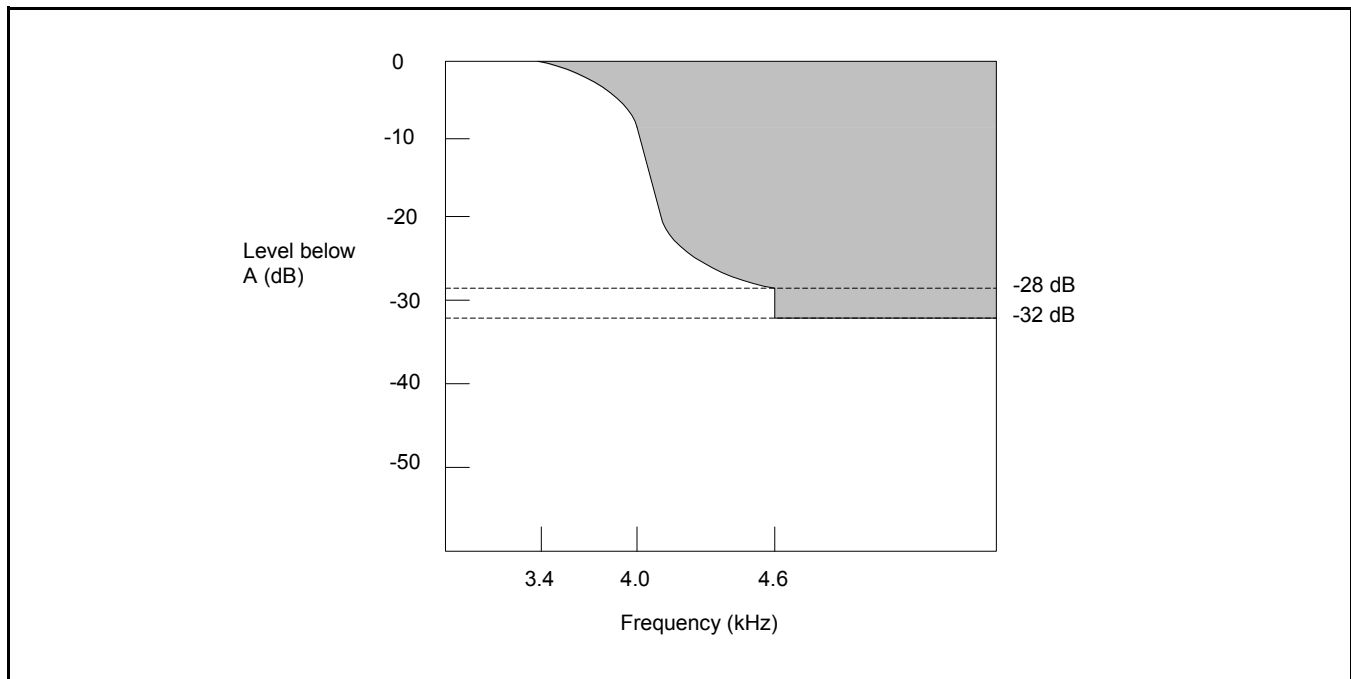

Figure 24 - Discrimination Against Out-of-Band Signals

7.13 Discrimination Against 12- and 16-kHz Metering Signals - Narrowband Codec Mode

If the Le88266/286 device is used in a metering application where 12- or 16-kHz tone bursts are injected onto the telephone line toward the subscriber, a portion of these tones may also appear at the transmit input. These Out-of-Band signals may cause frequency components to appear below 4 kHz at the digital output. For a 12-kHz or 16-kHz tone, the frequency components below 4 kHz are reduced from the input by at least 70 dB. The sum of the peak metering and signal voltages must be within the TAC - RAC pin overload level.

7.14 Spurious Out-of-Band Signals at the Analog Output - Narrowband Codec Mode

With PCM idle code being applied to the digital input and either a quiet 600 Ω termination or an open being applied to Tip and Ring, any single frequency tone between 0 and 16kHz measured at the analog output shall be less than -50dBm0.

With PCM code words representing a sine wave signal in the range of 300 Hz to 3400 Hz at a level of 0 dBm0 applied to the digital input, the level of the spurious Out-of-Band signals at the analog output is less than the limits shown below.

Frequency	Level
4.6 kHz to 40 kHz	-32 dBm0
40 kHz to 240 kHz	-46 dBm0
240 kHz to 1 MHz	-36 dBm0

With code words representing any sine wave signal in the range 3.4 kHz to 4.0 kHz at a level of 0 dBm0 applied to the digital input, the level of the signals at the analog output are below the limits in [Figure 25](#). The amplitude of the spurious Out-of-Band signals between 3400 Hz and 4600 Hz is given by the formula:

$$\text{Level} = \left[-14 - 14 \sin\left(\frac{\pi(f - 4000)}{1200}\right) \right] \text{ dBm0}$$

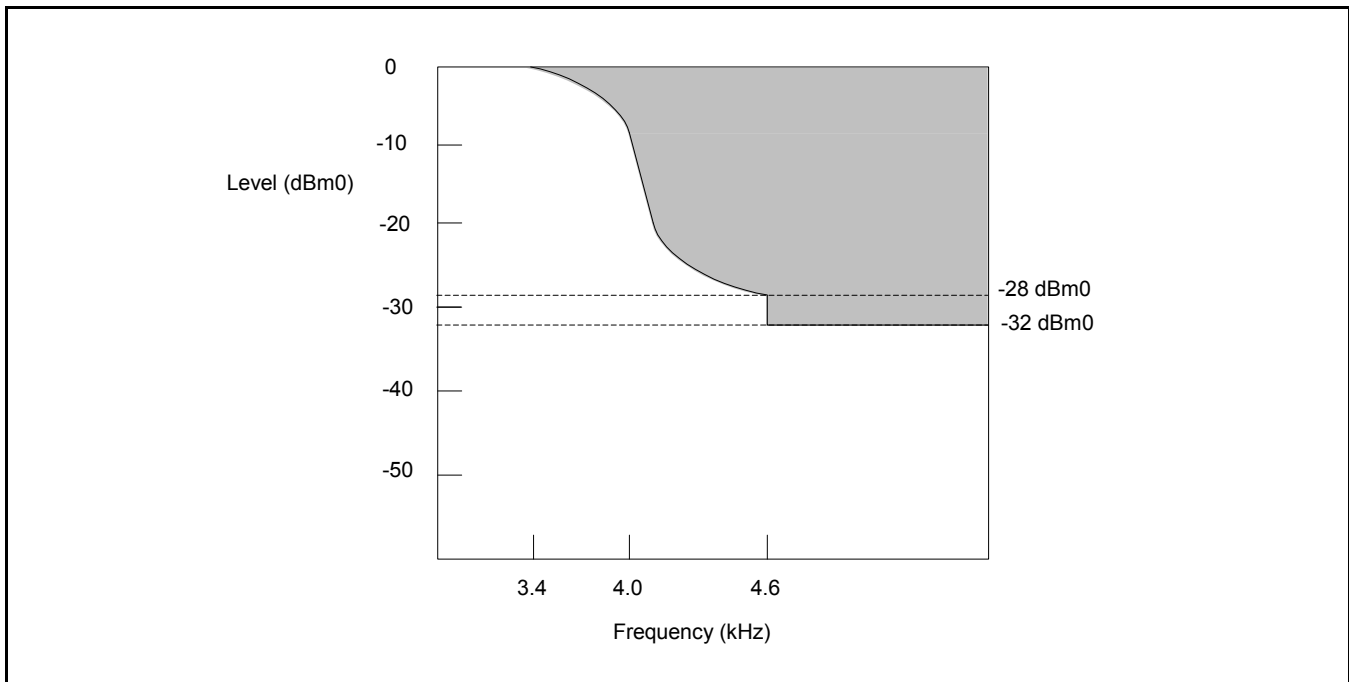

Figure 25 - Spurious Out-of-Band Signals

7.15 Overload Compression - Narrowband Codec Mode

[Figure 26](#) shows the acceptable region of operation for input signal levels above the reference input power (0 dBm0). The conditions for this figure are:

1. 1.2 dB < GX ≤ + 12 dB
2. -12 dB ≤ GR < -1.2 dB

3. Digital voice output of one VoicePort channel connected to digital voice input of a second VoicePort channel.
4. Measurement analog-to-analog.

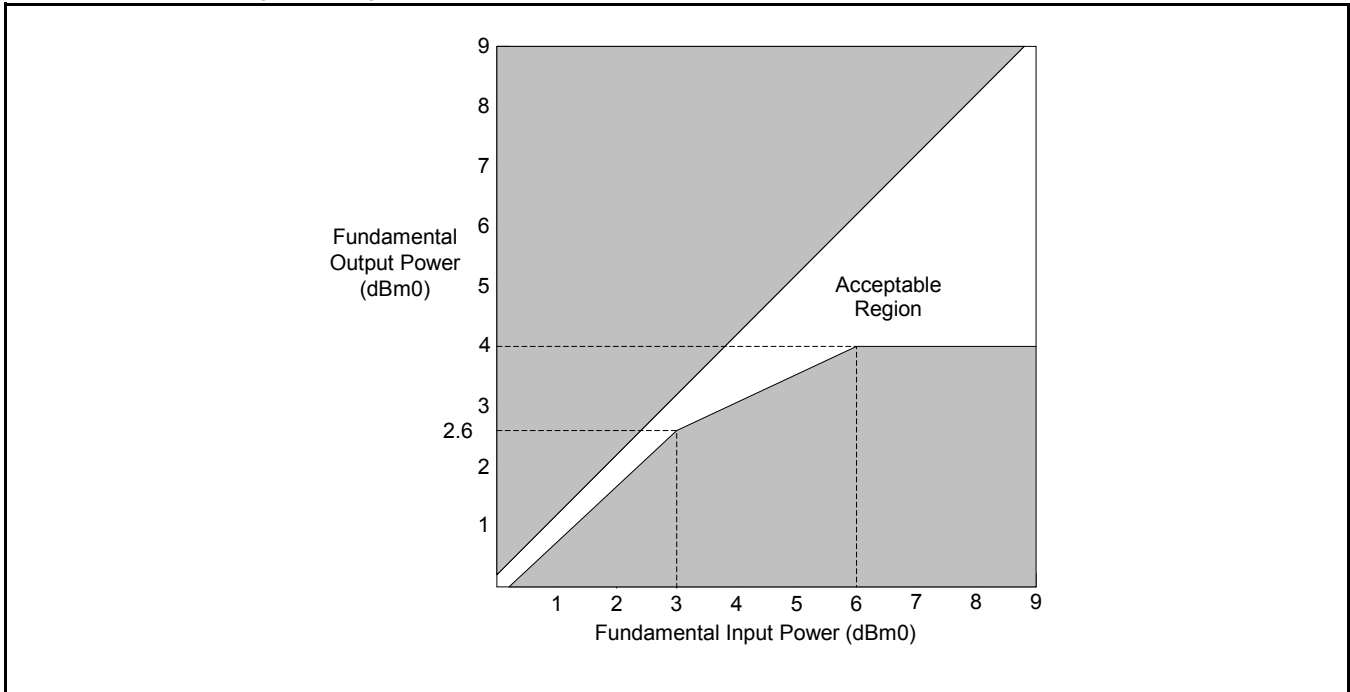

Figure 26 - Analog-to-Analog Overload Compression

7.16 Gain Linearity - Narrowband Codec Mode

The gain deviation relative to the gain at -10 dBm0 is within the limits shown in Figure 27 (A-law) and Figure 28 (μ -law) for either transmission path when the input is a sine wave signal of 1014 Hz.

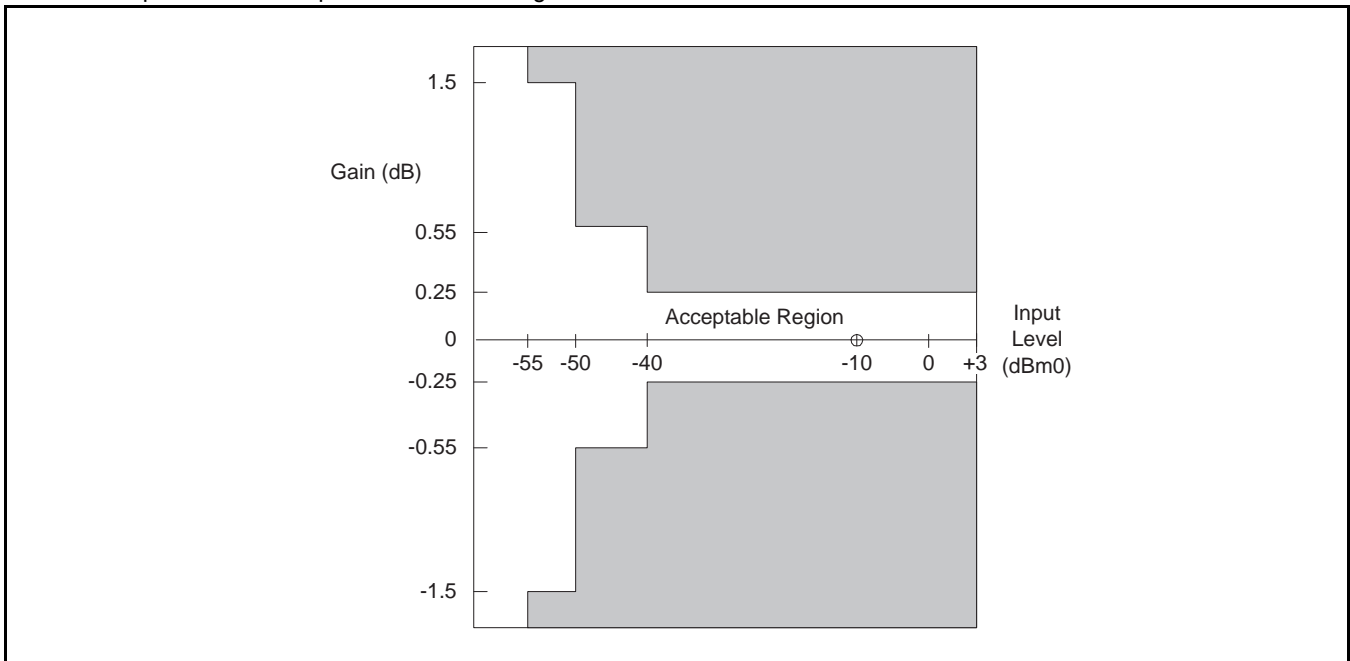

Figure 27 - A-law Gain Linearity with Tone Input (Both Paths)

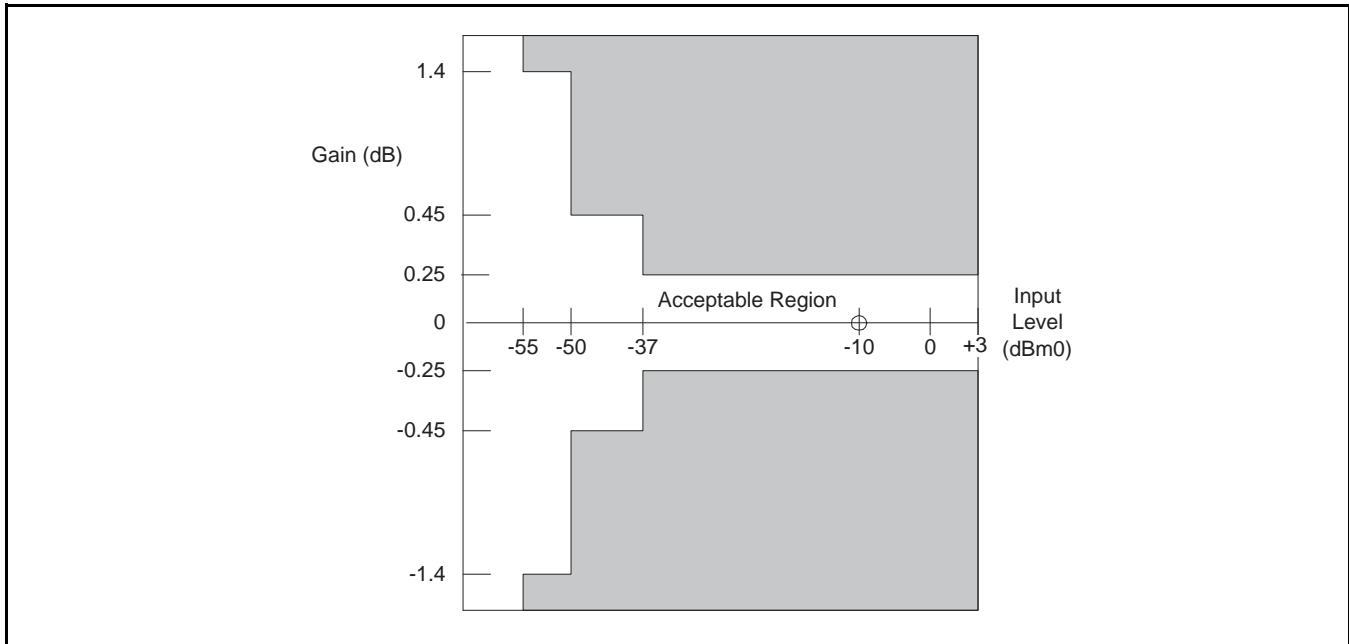

Figure 28 - μ -law Gain Linearity with Tone Input (Both Paths)

7.17 Total Distortion Including Quantizing Distortion - Narrowband Codec Mode

The signal to total distortion ratio will exceed the limits shown in [Figure 29](#) for either path when the input signal is a sine wave with a frequency of 1014 Hz, using psophometric weighting for A-law and C-message weighting for μ -law

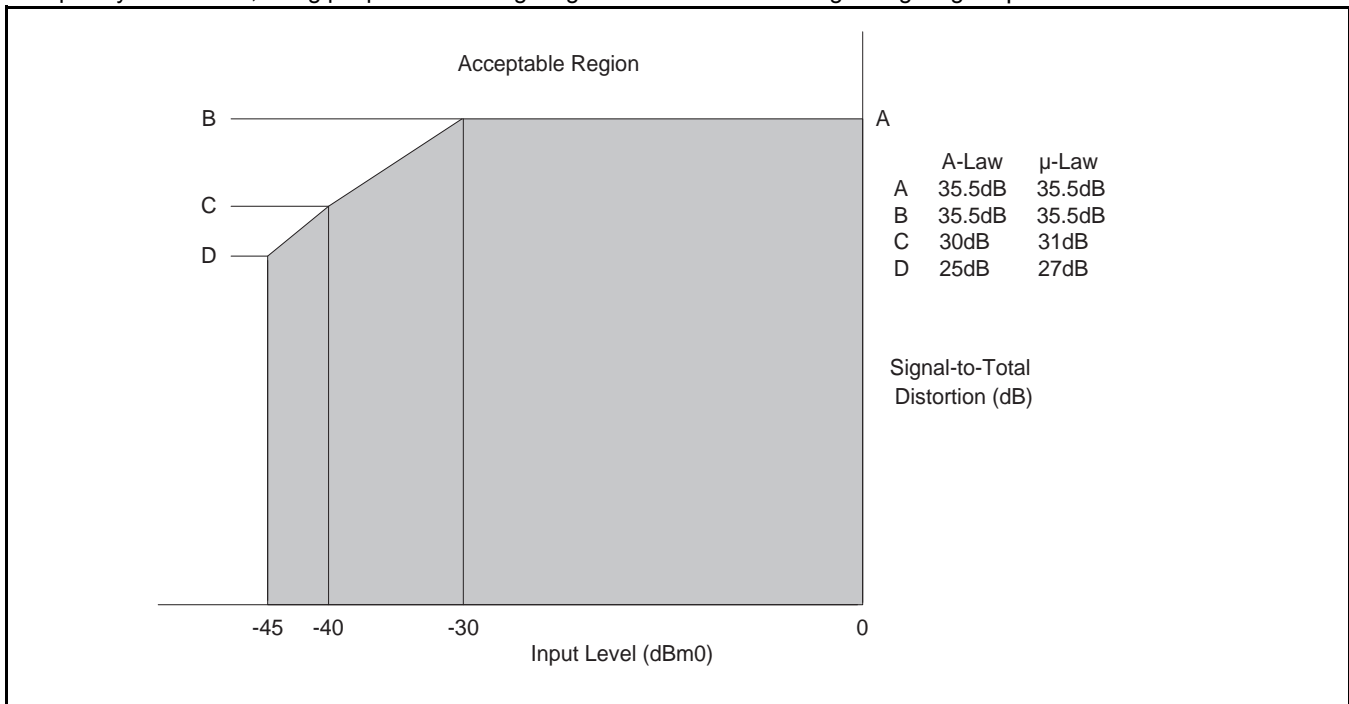

Figure 29 - Total Distortion with Tone Input (Both Paths)

7.18 Group Delay Distortion - Narrowband Codec Mode

For either transmission path, the group delay distortion is within the limits shown in [Figure 30](#). The minimum value of the group delay is taken as the reference. The signal level should be 0 dBm0.

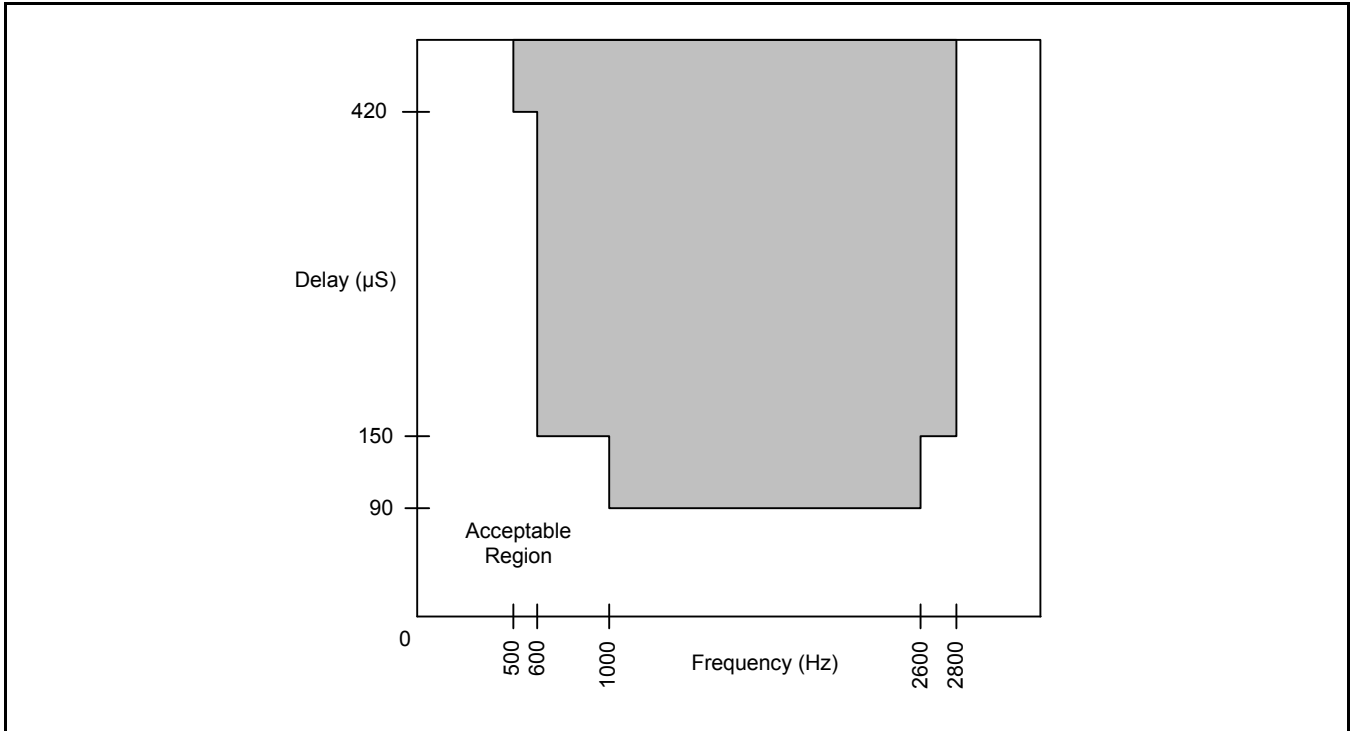

Figure 30 - Group Delay Distortion

7.19 Transmission Characteristics - Wideband Codec Mode

Description	Test Conditions	Min	Typ	Max	Unit	Note
TAC - RAC overload level	Active state GX = AX = 0 dB	3.4			Vpk	2.
Transmit level, A/D	0 dBm, GX = GX0, 1014 Hz		0		dBm0	
Receive level, D/A	0 dBm0, GR = GR0, 1014 Hz		0		dBm	
Gain accuracy, D/A or A/D	0 dBm0, 1014 Hz, off-hook	-0.5		+0.5	dB	
Gain accuracy, D/A or A/D	0 dBm0, 1014 Hz, on-hook	-0.75		+0.25		1.
Attenuation distortion	100 Hz to 6.0 kHz	-0.25		+0.25		3.
Single frequency distortion	0dBm0, Linear Mode 50 Hz to 7.0 kHz			-50		4.
Signal to noise + distortion	0dBm0, Linear Mode 50 Hz to 7.0 kHz	50				4.
Second harmonic distortion, D-A	GR = 0 dB			-55		
Idle channel noise, V _{TIPD} - V _{RINGD} DXA, Digital out	DRA, Digital input = 0 Linear, 0 dBr V _{TIPD} - V _{RINGD} = 0 VAC Linear, 0 dBr			-67 -67	dBm0p dBm0p	5. 5.
End-to-end absolute group delay	B = Z = 0; X = R = 1, C/L = 0			340	µs	1. , 6.
Two-wire return loss	50 to 7000 Hz	20	26		dB	1.
Longitudinal to Metallic balance TIPD - RINGD or DXA	50 to 7000 Hz	48			dB	7.
DRA to Longitudinal signal generation	300 to 7000 Hz	40				1.
Longitudinal current capability, TIPD or RINGD	Active state	8.5			mArms	1.
Longitudinal impedance at TIPD or RINGD	0 to 100 Hz, LI = 0		100		Ω/pin	1.

Notes:

1. This parameter is guaranteed by characterization or correlation to other tests. Not tested in production.
2. Overload level is defined when THD = 1%.
3. See [Figure 31](#) and [Figure 32](#).
4. 0 dBm0 input signal, 50 to 7000 Hz measurement at any other frequency, 50 to 7000 Hz.
5. No single frequency component in the range above 7600 Hz may exceed a level of -55 dBm0.
6. The End-to-End Group Delay is the absolute group delay of the echo path with the B filter turned off.
7. This parameter is tested at 1 kHz in production. Performance at other frequencies is guaranteed by characterization.

7.20 Attenuation Distortion - Wideband Codec Mode

The signal attenuation in either path is nominally independent of the frequency. The deviations from nominal attenuation will stay within the limits shown in [Figure 31](#) and [Figure 32](#). The reference frequency is 1014 Hz and the signal level is -10 dBm0.

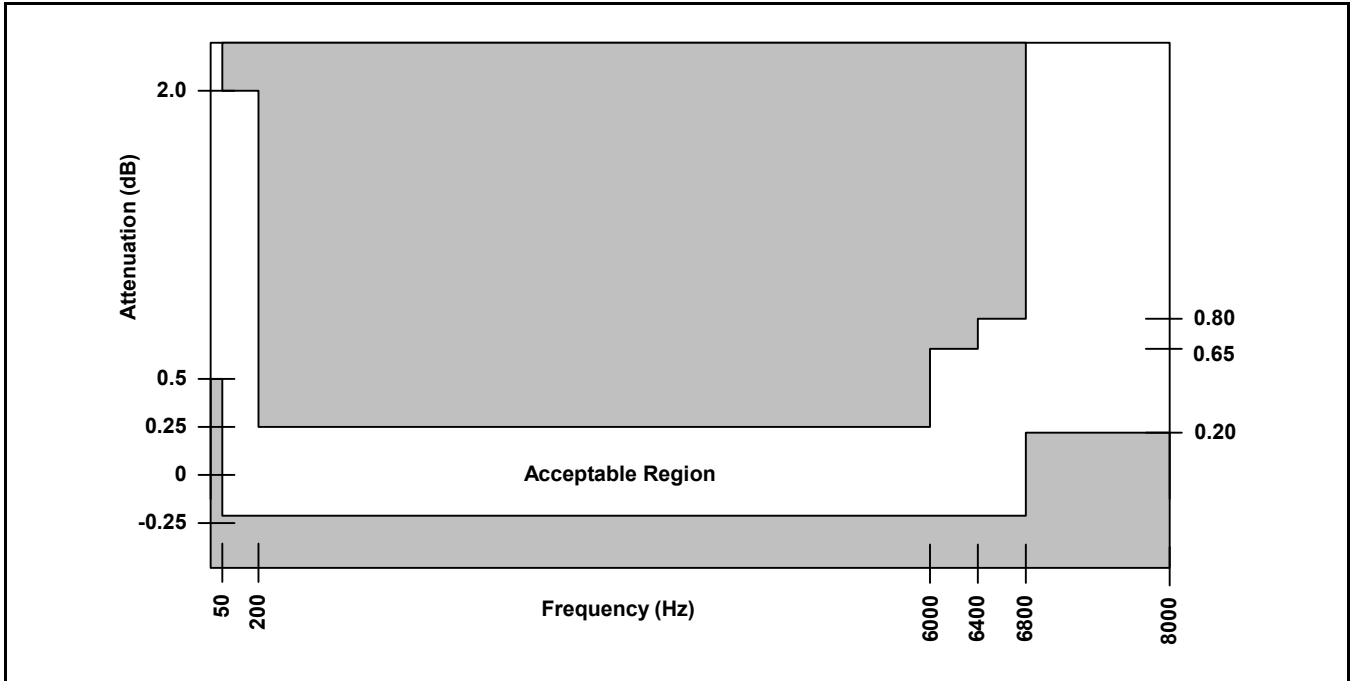

Figure 31 - Transmit Path Attenuation vs. Frequency

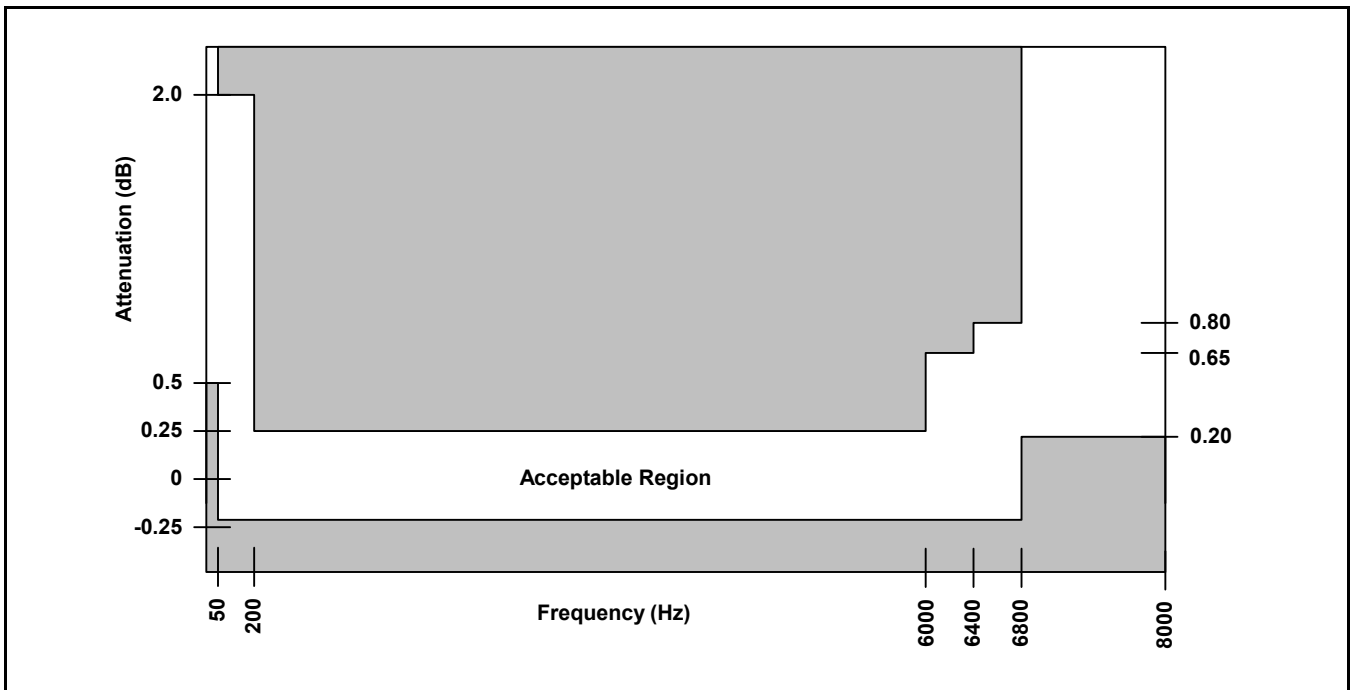

Figure 32 - Receive Path Attenuation vs. Frequency

7.21 Group Delay Distortion - Wideband Codec Mode

For either transmission path, the group delay distortion is within the limits shown in [Figure 33](#). The minimum value of the group delay is taken as the reference. The signal level should be 0 dBm0.

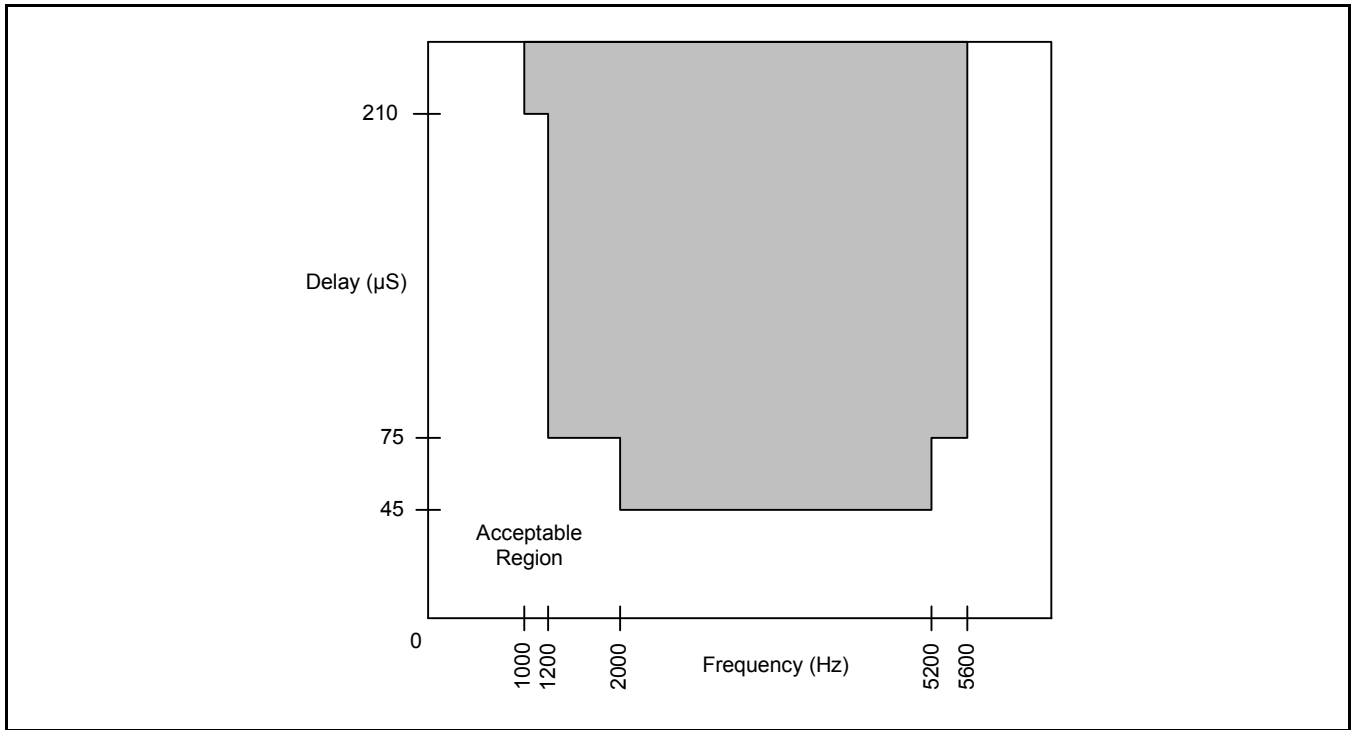

Figure 33 - Group Delay Distortion

8.0 Switching Characteristics and Waveforms

The following are the switching characteristics over operating range (unless otherwise noted). Min and max values are valid for all digital outputs with a 115-pF load. (See [Figure 34](#) and [Figure 35](#) for the microprocessor interface timing diagrams.)

8.1 Microprocessor Interface Timing

No.	Symbol	Parameter	Min	Typ	Max	Unit	Note
1	t_{DCY}	Data clock period	122			ns	
2	t_{DCH}	Data clock HIGH pulse width	48				
3	t_{DCL}	Data clock LOW pulse width	48				
4	t_{DCR}	Rise time of clock			25		
5	t_{DCF}	Fall time of clock			25		
6	t_{ICSS}	Chip select setup time, Input mode	30		$t_{DCY} - 10$		
7	t_{ICSH}	Chip select hold time, Input mode	0		$t_{DCH} - 20$		
8	t_{ICSL}	Chip select pulse width, Input mode		$8t_{DCY}$			
9	t_{ICSO}	Chip select off time, Input mode	2500				
10	t_{IDS}	Input data setup time	25				
11	t_{IDH}	Input data hold time	20				
12	t_{OLH}	I/O1, I/O2 output latch valid			2500		
13	t_{OCSS}	Chip select setup time, Output mode	30		$t_{DCY} - 10$		
14	t_{OCSH}	Chip select hold time, Output mode	0		$t_{DCH} - 20$		
15	t_{OCSL}	Chip select pulse width, Output mode		$8t_{DCY}$			
16	t_{OCSSO}	Chip select off time, Output mode	2500				
17	t_{ODD}	Output data turn on delay			36		1.
18	t_{ODH}	Output data hold time	3				
19	t_{ODOF}	Output data turn off delay			36		
20	t_{ODC}	Output data valid			36		
21	t_{RST}	Reset pulse width	50			μ s	

Notes:

1. The first data bit is enabled on the falling edge of \overline{CS} or on the falling edge of DCLK, whichever occurs last.

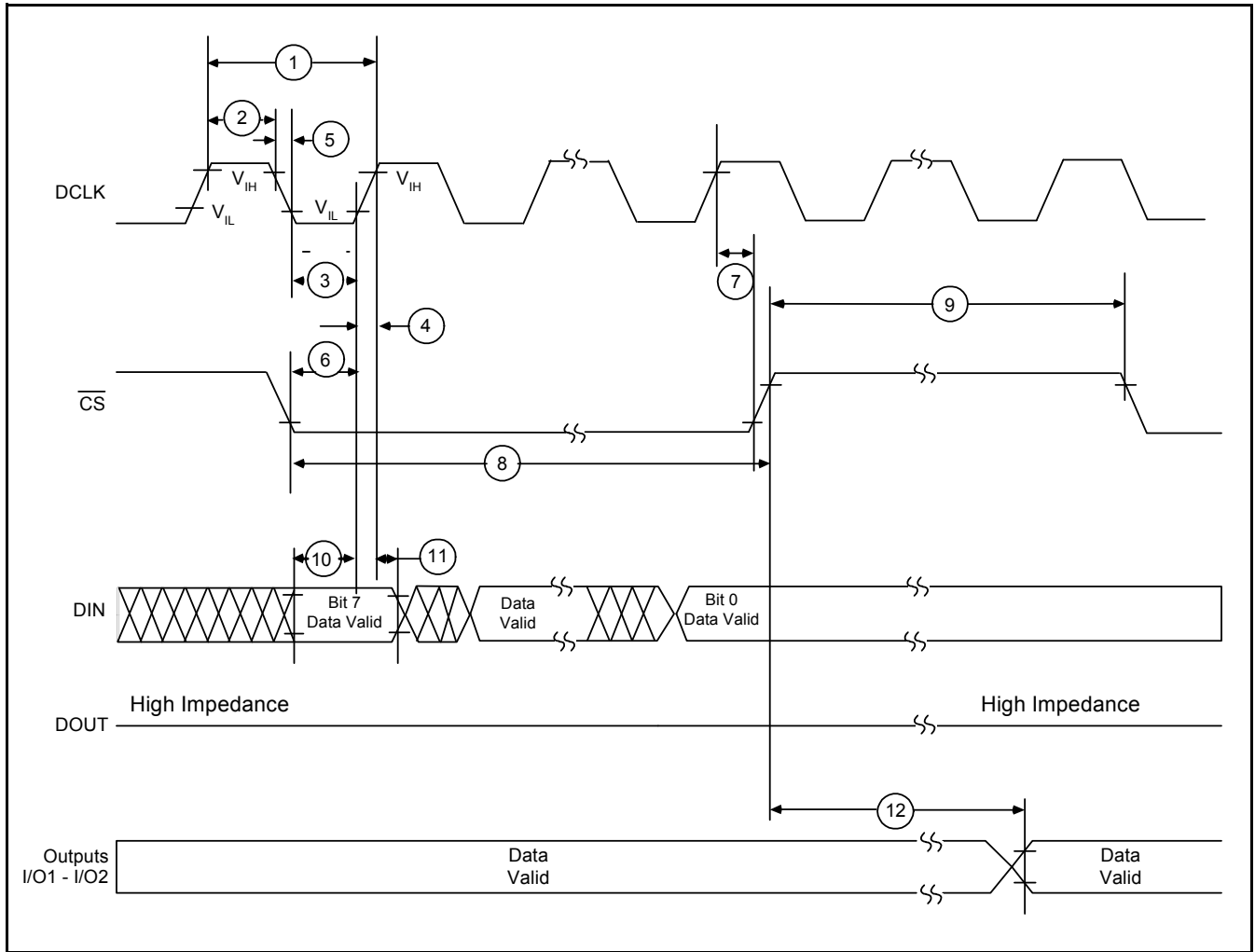

Figure 34 - Microprocessor Interface (Input Mode)

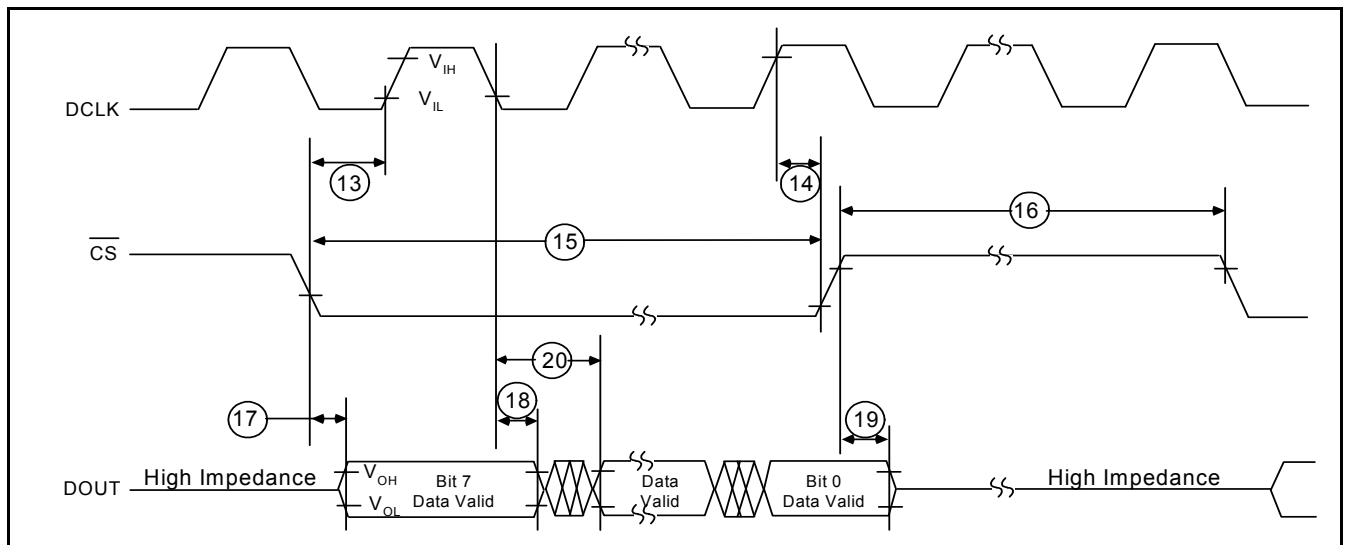

Figure 35 - Microprocessor Interface (Output Mode)

8.2 PCM Interface Timing

PCLK shall not exceed 8.192 MHz. Pull-up resistor to DVDD of 240 Ω is attached to \overline{TSCA} . (See [Figure 36](#) through [Figure 39](#) for the PCM interface timing diagrams.)

No.	Symbol	Parameter	Min.	Typ	Max	Unit	Note
22	t_{PCY}	PCM Clock (PCLK) period	122		977	ns	1.
23	t_{PCH}	PCLK HIGH pulse width	48				
24	t_{PCL}	PCLK LOW pulse width	48				
25	t_{PCF}	PCLK fall time			15		
26	t_{PCR}	PCLK rise time			15		
27	t_{FSS}	FS setup time	25		$t_{PCY}-30$		
28	t_{FSH}	FS hold time	50				
29	t_{FST}	Allowed PCLK or FS jitter time - narrowband	-50		50		1.
29	t_{FST}	Allowed PCLK or FS jitter time - wideband	-25		25		1.
30	t_{TSD}	Delay to \overline{TSCA} valid	5		80		2.
31	t_{TSO}	Delay to \overline{TSCA} off	5				2. , 3.
32	t_{DXD}	PCM data output delay	5		70		
33	t_{DXH}	PCM data output hold time	5		70		
34	t_{DXZ}	PCM data output delay to high Z	10		70		
35	t_{DRS}	PCM data input setup time	25				
36	t_{DRH}	PCM data input hold time	5				

Notes:

1. The PCLK frequency must be an integer multiple of the frame sync (FS) frequency. Frame sync is expected to be an accurate 8-kHz pulse train. The actual PCLK rate depends on the CSEL bit setting in the Device Configuration register. The minimum frequency is 1.024MHz and the maximum frequency is 8.192 MHz.
If PCLK has jitter, care must be taken to ensure that all setup, hold, and pulse width requirements are met.
2. \overline{TSC} is delayed from FS by a typical value of $N \cdot t_{PCY}$, where N is the value stored in the time/clock-slot register.
3. t_{TSO} is defined as the time at which the output achieves the Open Circuit state.

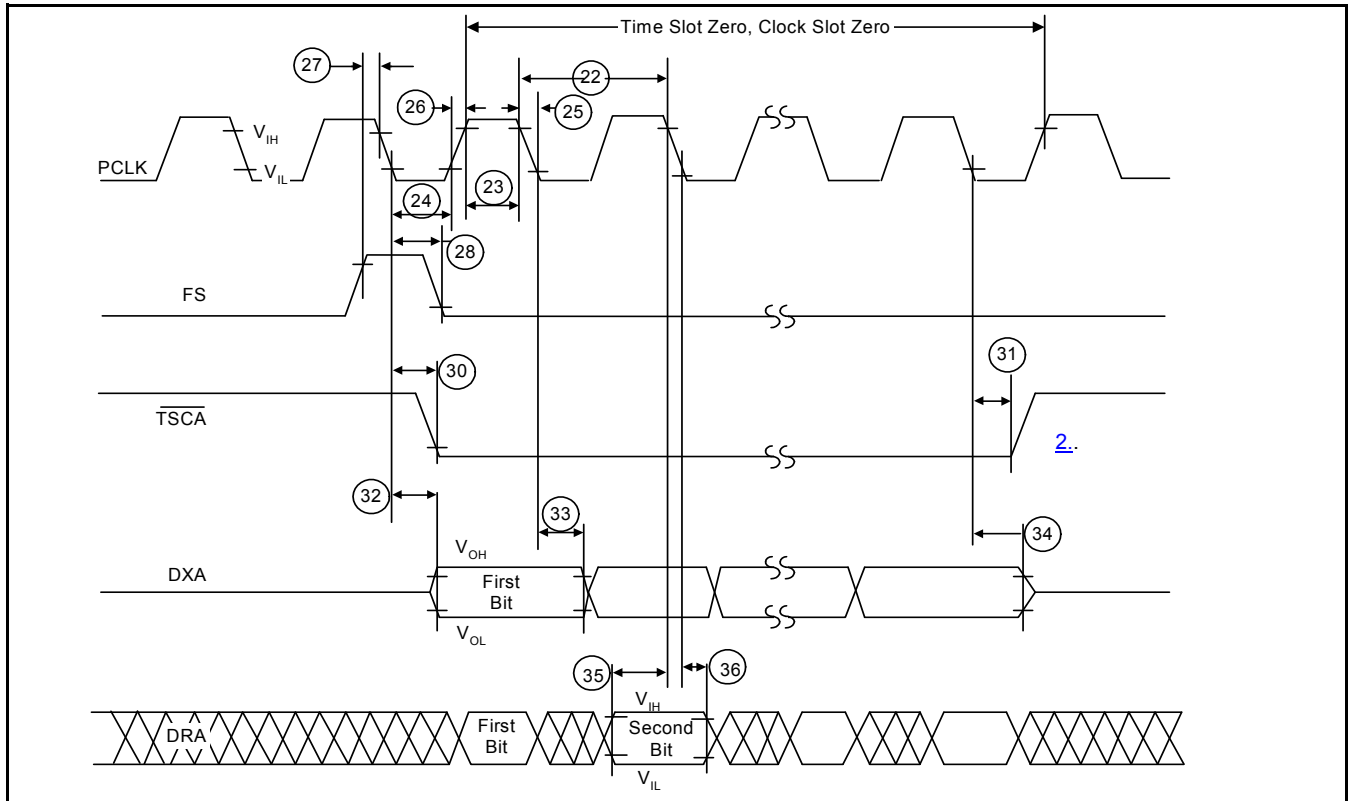

Figure 36 - PCM Highway Timing for XE = 0 (Transmit on Negative PCLK Edge)

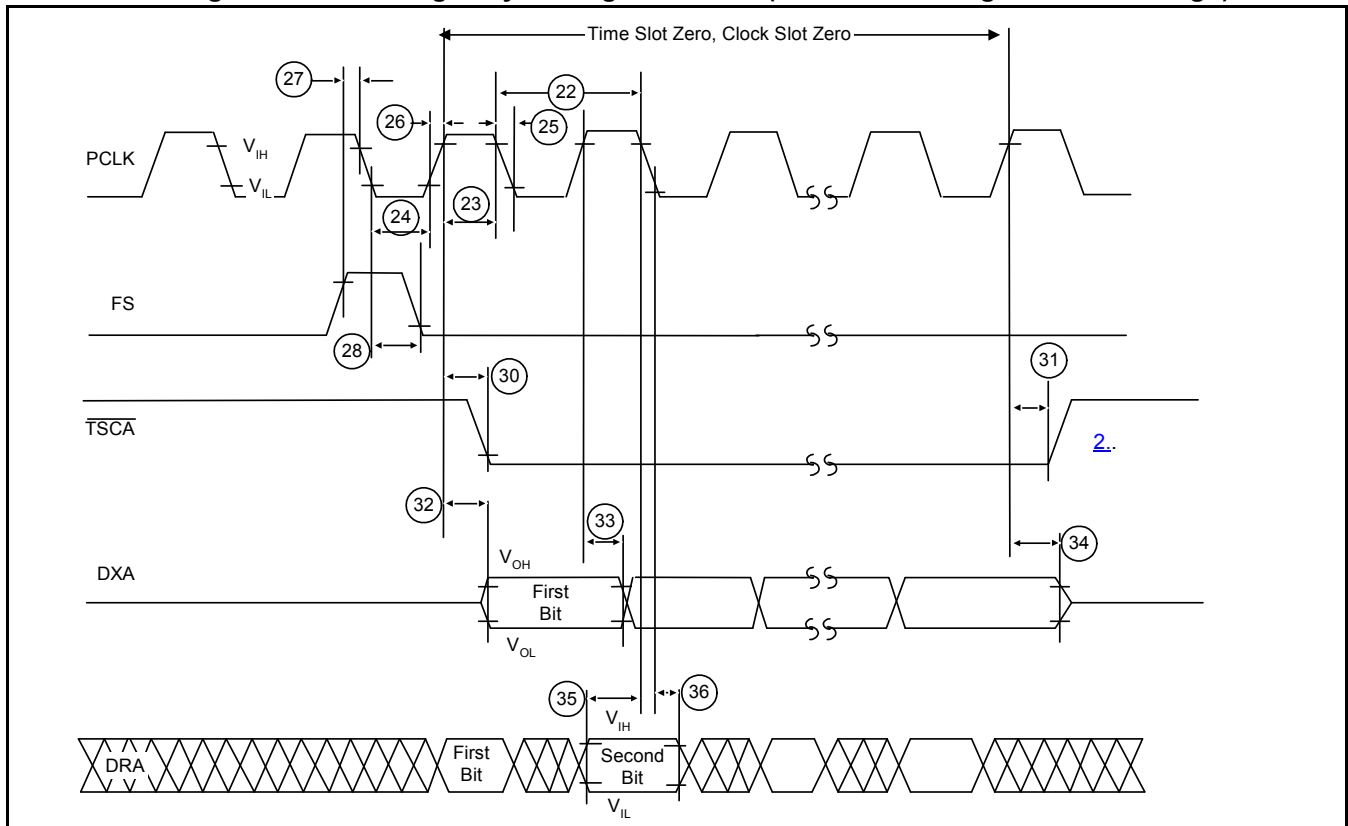

Figure 37 - PCM Highway Timing for XE = 1 (Transmit on Positive PCLK Edge)

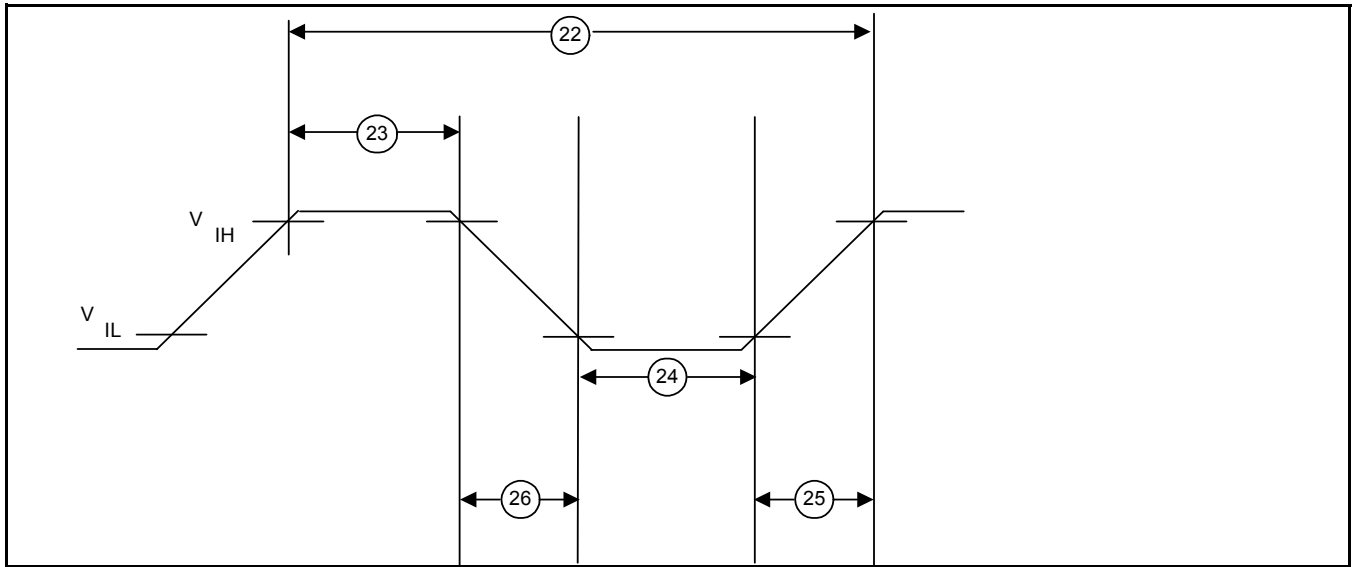

Figure 38 - PCM Clock Timing

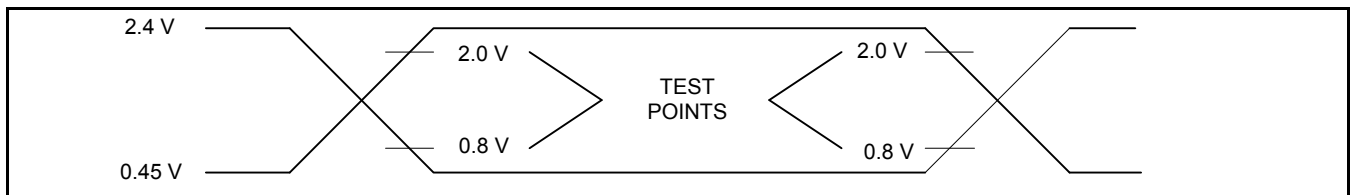

Figure 39 - Input and Output Waveforms for AC Tests

8.3 GCI Timing

(See [Figure 40](#) and [Figure 41](#) for the GCI interface timing diagrams.)

No.	Symbol	Parameter	Min	Typ	Max	Unit	Note
37	J_{DCL}	DCL Jitter			50	ns	1.
38	t_R, t_F	Rise/fall time			60		
39	t_{DCL}	Period, $F_{DCL} = 2048$ kHz	488.23	488.28	488.33		
		$F_{DCL} = 4096$ kHz	244.11	244.14	244.17		
40	t_{WH}, t_{WL}	Pulse width	90				
41	t_{SF}	Setup time	70		$t_{DCL}-50$		
42	t_{HF}	Hold time	50				
43	t_{WFH}	High pulse width	130				
44	t_{DDC}	Delay from DCL edge			100		
45	t_{DDF}	Delay from FS edge			150		
46	t_{SD}	Data setup	$t_{WH}+20$				
47	t_{HD}	Data hold	50				

Notes:

1. If DCL has jitter, care must be taken to ensure that all setup, hold, and pulse width requirements are met.

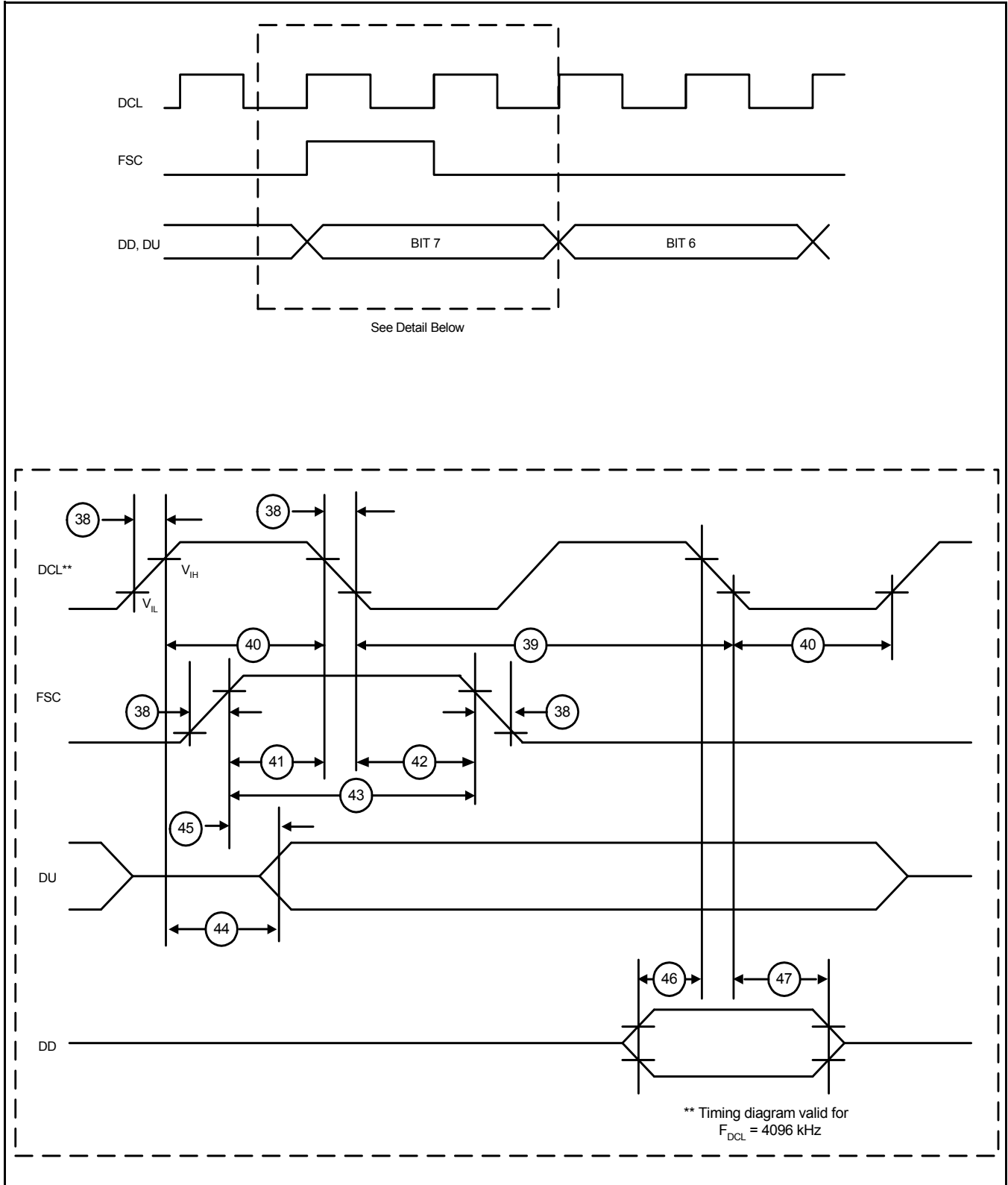

Figure 40 - 4.096 MHz DCL Operation

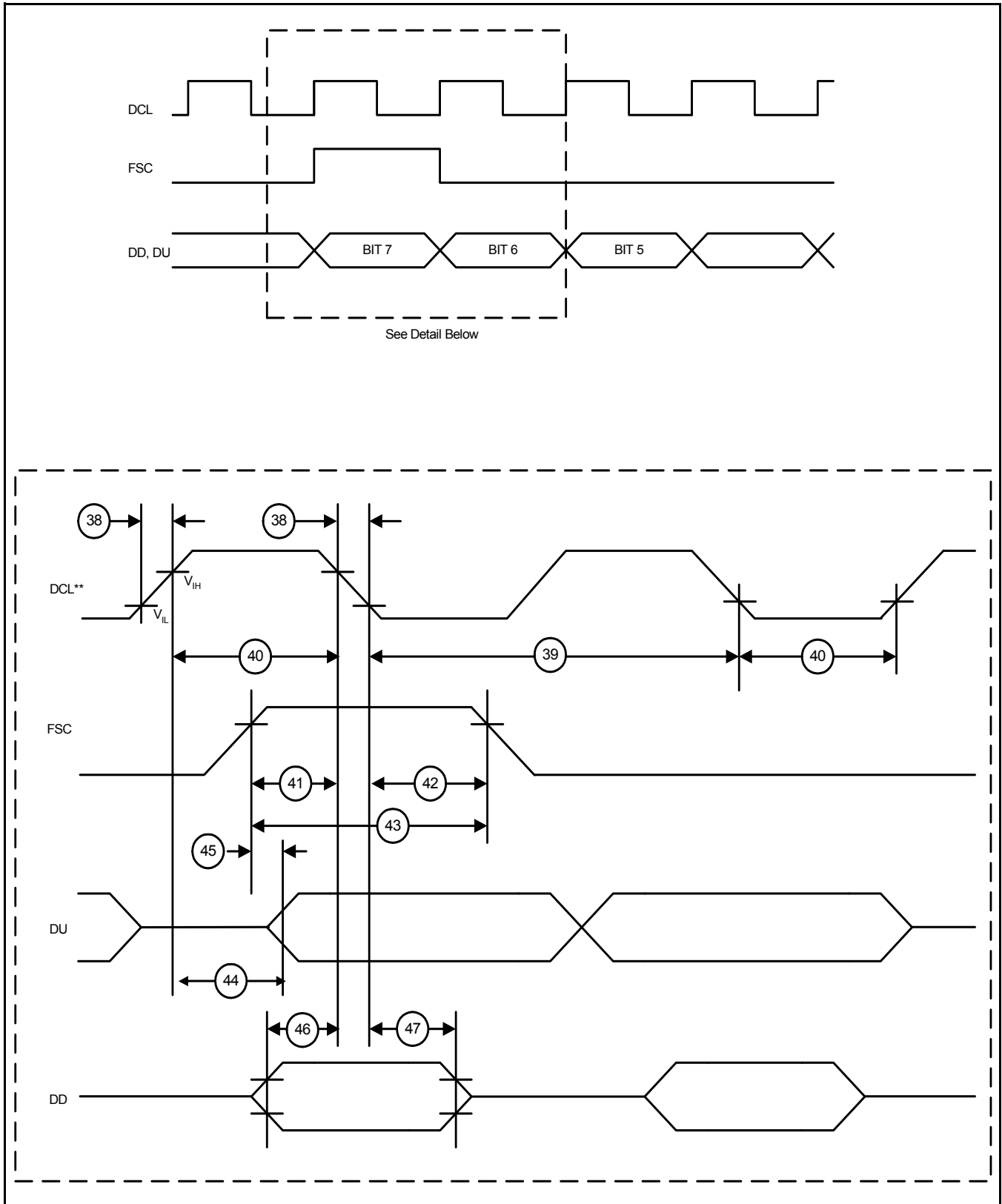

Figure 41 - 2.048 MHz DCL Operation

8.4 Switcher Output Timing

(See [Figure 42](#) for the SWOUTY, SWOUTZ timing diagram, and note [5](#).)

No.	Symbol	Parameter	Min	Typ	Max	Unit	Notes
1	Tfall	Output Fall Time		30		ns	1
2	Trise	Output Rise Time		30		ns	1
3LP	TPeriod	Period for Low Power Mode		20.833		μs	2,5
4LP	Tmax	Max On-Time for Low Power Mode		1.830	1.845	μs	2,5
3MP	TPeriod	Period for Medium Power Mode		10.417		μs	3,5
4MP	Tmax	Max On-Time for Medium Power Mode		1.830	1.845	μs	3,5
3HP	TPeriod	Period for High Power Mode		2.604		μs	4,5
4HP	Tmax	Max On-Time for High Power Mode		1.830	1.845	μs	4,5
	Duty Cycle LP	Duty Cycle Low Power Mode	0		8.8	%	2,5
	Duty Cycle MP	Duty Cycle Medium Power Mode	0		17.6	%	3,5
	Duty Cycle HP	Duty Cycle High Power Mode	0		70.3	%	4,5
5	Y to Z offset	Delay from SWOUTZ to SWOUTY on		1.302		μs	4,5
		SWISY leading edge blanking period		120		ns	

Notes:

- Measured with an RC load on SWOUTx of 330 pF in series with 180 Ω to ground.
- Register [E6/E7h Write/Read Switching Regulator Control](#) is loaded with low power mode 01h.
- Register [E6/E7h Write/Read Switching Regulator Control](#) is loaded with medium power mode 02h.
- Register [E6/E7h Write/Read Switching Regulator Control](#) is loaded with high power mode 03h.
- Timing values assume SWFS[1:0] = 00b in [E4/E5h Write/Read Switching Regulator Parameters](#). Stated periods and on times scale inversely with frequency selected.

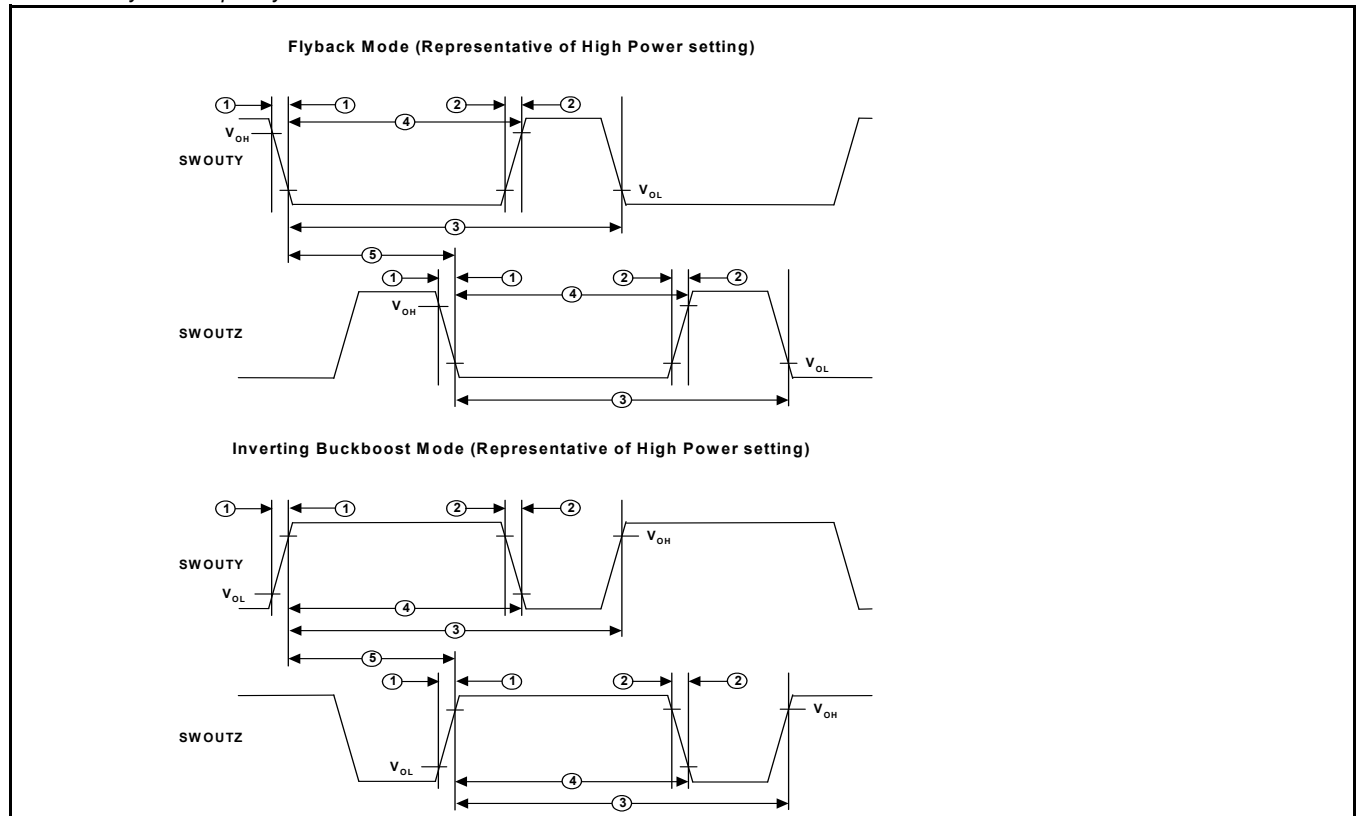

Figure 42 - Switcher Output Waveform SWOUTY, SWOUTZ

9.0 Applications

The Le88266/286 VoicePort device implements a complete dual channel interface between a digital highway (PCM/MPI or GCI) and two telephone lines. The Le88266/286 device provides access to time-critical information, such as off/on-hook and ring trip, via a single read operation. When various country or transmission requirements must be met, the Le88266/286 device can be reprogrammed to meet the required DC feed, ringing and transmission characteristics.

Several Le88266/286 devices can be tied together in one bus interfacing to a common PCM or GCI interface. In MPI mode, the Le88266/286 device is controlled through the microprocessor interface.

The following application example uses the Le88266/286 device in a two-battery switching configuration. The power can be provided by external supplies or from the example dual output supply shown in [Figure 44](#) using the SWOUTY controller.

9.1 Application Circuit

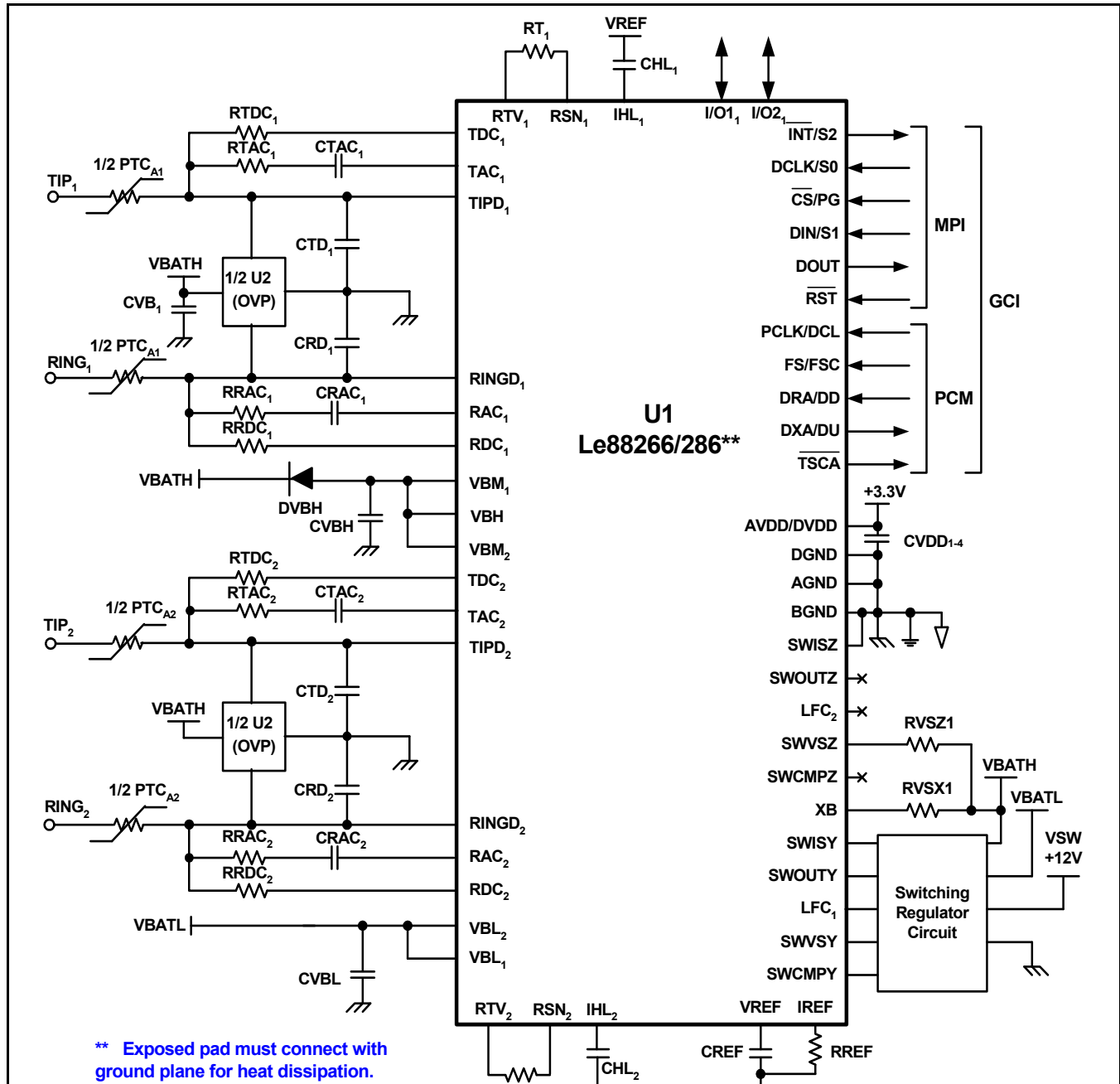

Figure 43 - Le88266/286 device Application Circuit

Circuit shown for a two-channel Le88266 battery switching application
 -81 V High and Mid batteries (70 Vpk ringing with up to 5REN load)
 -27 V regulated low battery, with +12 V nominal VSW input

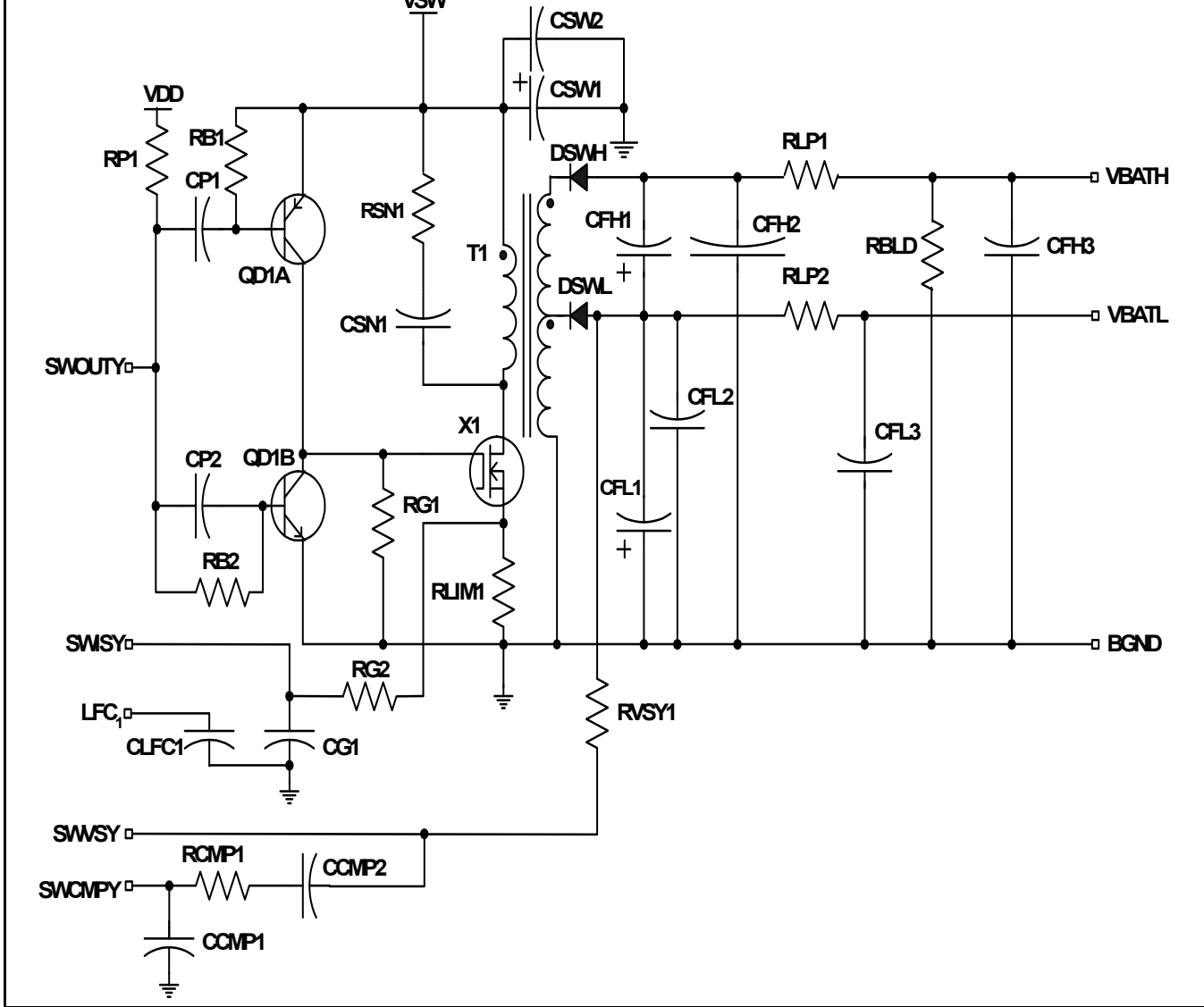

Figure 44 - Le88266/286 Switching Regulator Circuit

9.2 Le88266/286 VoicePort™ Device Parts List

The following list defines the parts and part values required to meet target specifications based on the application circuits shown in [Figure 43](#) and [Figure 44](#).

Item	Qty.	Type	Value	Tol.	Rating	Comments
C _{H1,2}	2	Ceramic Capacitor, X5R	4.7 μF	20%	6.3 V	Panasonic ECJ-1VBOJ475M 0603
C _{RAC1,2} , C _{TAC1,2}	4	Ceramic Capacitor, X7R	0.068 μF	10%	200 V*	Kemet 12062C683KAT2A 1206
C _{RD1,2} , C _{TD1,2}	4	Ceramic Capacitor, X7R	0.022 μF	10%	200 V*	Kemet 08052C223KAT2A 0805
C _{REF}	1	Ceramic Capacitor, X5R	10μF	10%	6.3 V	Panasonic ECJ-2FB0J106M 0805
C _{VDD1,2,3,4}	4	Ceramic Capacitor, X5R	0.1 μF	20%	10 V	Murata GRM155R61A104KA01D 0402
D _{VBH}	1	Diode	250 V		0.25 A	Fairchild BAS21
PTC _{A1,2}	2	Dual PTC, 0.13A Hold	7 Ω		250 V	Bourns MF-SD013/250
R _{RAC1,2} , R _{TAC1,2}	4	Resistor	3.01 kΩ	1%	1/8 W	Panasonic ERJ-6ENF3011V 0805
R _{RDC1,2} , R _{TDC1,2} , R _{VSX} , R _{VSY} , R _{VSZ}	7	Resistor	402 kΩ	1%	1/8 W	Panasonic ERJ-6ENF4023V 0805
R _{REF}	1	Resistor	75 kΩ	1%	1/16 W	Panasonic ERJ-2RKF7502X 0402
R _{T1,2}	2	Resistor	47.5 kΩ	1%	1/16 W	Panasonic ERJ-2RKF4752X 0402
U1	1	Dual Channel ABS VoicePort Device			-105 V or -120 V	Microsemi Le88266/286
U2	1	Dual Protector			150 V	Bourns TISP61089Q or ST LCDP1521RL
SWITCHING POWER SUPPLY COMPONENTS						
C _{COMP1}	1	Ceramic Capacitor, X7R	330 pF	10%	50 V	Murata GRM155R71H331KA01D 0402
C _{COMP2}	1	Ceramic Capacitor, X7R	4700 pF	10%	50 V	Panasonic ECJ-1VC1H040C 0402
C _{FH1}	1	Electrolytic Capacitor	33 μF	20%	100 V	Panasonic EEUFC2A330 TH
C _{FH2} , C _{FH3} , C _{VB1} , C _{VBH}	4	Ceramic Capacitor, X7R	0.1 μF	10%	200 V	Kemet C1206C104K1RACTU 1206
C _{FL1}	1	Electrolytic Capacitor	100 μF	20%	50 V	Panasonic EEUFC1H101 TH
C _{FL2} , C _{SW2} , C _{VBL}	3	Ceramic Capacitor, X7R	0.1 μF	10%	50 V	Murata GCM21BR71H104KA37L 0805
C _{FL3}	1	Ceramic Capacitor, X7R	0.47 μF	10%	50 V	Murata GRM21BR71H474KA88L 0805
C _{G1} , C _{P1} , C _{P2}	3	Ceramic Capacitor, X7R	220 pF	10%	25 V	Yageo 0402CG221J8B200 0402
C _{LFC1}	1	Ceramic Capacitor, X7R	0.1 μF	20%	10 V	Murata GRM155R61A104KA01D 0402
C _{SN1}	1	Ceramic Capacitor, X7R	220 pF	10%	100 V	Murata GRM155R71H221KA01D 0603
C _{SW1}	1	Capacitor Low ESR	100 μF	20%	25 V	Panasonic EEU-FC1E101S TH
D _{SWH} , D _{SWL}	2	Rectifier Diode	Ultra Fast	<50 nS	1 A/200 V	Fairchild ES1D
Q _{D1A/B}	1	Dual transistor	100 mA		40 V	On Semi MBT3946DW1T1LRG SOT-363
R _{B1}	1	Resistor	560 Ω	5%	1/10 W	Panasonic ERJ-2GEYJ561V 0603
R _{B2} , R _{G1} , R _P	3	Resistor	10 kΩ	5%	1/16 W	Panasonic ERJ-2GEJ103X 0402
R _{G2}	1	Resistor	1.00 kΩ	1%	1/16 W	Panasonic ERJ-2RKF1001X 0402
R _{BLD}	1	Resistor	75 kΩ	5%	1/4 W	Panasonic ERJ-8GEYJ753V 1206
R _{COMP}	1	Resistor	402 kΩ	1%	1/16 W	Panasonic ERJ-3EKF4023V 0402
R _{LP1}	1	Resistor	20 Ω	5%	1/4 W	Panasonic ERJ-8GEYJ200V 1206
R _{LP2}	1	Resistor	10 Ω	5%	1/4 W	Panasonic ERJ-8GEYJ100V 1206
R _{SN1}	1	Resistor	33 Ω	5%	1/4 W	Panasonic ERJ-8GEYJ330V 1206
R _{LIM1}	1	Resistor	0.020 Ω	1%	1/4 W	Yageo PF1206FRF070R02L 1206
T ₁	1	Flyback Transformer				UMEC TG-UTB01906S
X ₁	1	MOSFET, N-channel	68 mΩ	4 A	60 V	Diodes DMN6068SE SOT-223

Note: 200-V Capacitors marked with * are needed for applications using the Le88286 Device. 100-V capacitors can be used in Le88266 designs.

10.0 Command Description and Formats

10.1 Command Field Summary

A microprocessor can program and control the Le88266/286 device using the MPI or GCI. Data programmed previously can be read out for verification. See [Detailed Descriptions Of Commands, on page 72](#) for the channel and global chip parameters assigned.

10.2 MPI Description

If desired, multiple voice channel data can be programmed simultaneously with identical information by setting multiple Channel Enable bits. Channel Enable bits are contained in the Channel Enable register and written or read using MPI Command 4A/4Bh. If multiple Channel Enable bits are set for a read operation, only voice data from the first enabled channel will be read. Other functions within the device are accessible on a global basis independent of the setting of the Channel Enable bits.

The MPI consists of a serial data input (DIN) a data output (DOUT), a data clock (DCLK), and a chip select (\overline{CS}). The scope of the commands can be either Global or Voice Channel specific, as indicated in the [Summary of Commands, on page 70](#). Access to the Voice Channel commands are controlled by the voice Channel Enable bits (EC1 and EC2) in the [4A/4Bh Write/Read Channel Enable and Operating Mode Register, on page 74](#). The serial input consists of 8-bit commands that can be followed by additional bytes of input data, or by the Le88266/286 device sending out bytes of data. All data input and output is MSB (D7) first and LSB (D0) last. All data bytes are read or written one at a time, with \overline{CS} going High for at least a minimum off period before the next byte is read or written. Only a single channel should be enabled during read commands.

All commands that require additional input data to the device must have the input data as the next N words written into the device (for example, framed by the next N transitions of \overline{CS}). All unused bits must be programmed as 0 (unless otherwise noted) to ensure compatibility with future parts. All commands that are followed by output data will cause the device to output data for the next N transitions of \overline{CS} going Low. The Le88266/286 device will not accept any commands until all the data has been shifted out. The output values of unused bits are not specified.

An MPI cycle is defined by transitions of \overline{CS} and DCLK. If the \overline{CS} lines are held in the High state between accesses, the DCLK may run continuously with no change to the internal control data. Using this method, the same DCLK can be run to a number of Le88266/286 devices, and the individual \overline{CS} lines will select the appropriate device to access. Between command sequences, DCLK can stay in the High state indefinitely with no loss of internal control information regardless of any transitions on the \overline{CS} lines. Between bytes of a multibyte read or write command sequence, DCLK can also stay in the High state indefinitely. DCLK can stay in the Low state indefinitely with no loss of internal control information, provided the \overline{CS} line remains at a High level.

If a low period of \overline{CS} contains less than 8 positive DCLK transitions, it is ignored. If it contains 8 to 15 positive transitions, only the last 8 transitions matter. If it contains 16 or more positive transitions, a hardware reset in the part occurs. If the chip is in the middle of a read sequence when \overline{CS} goes Low, data will be present at the DOUT pin even if DCLK has no activity.

10.3 Summary of Commands

Hex*	Description	Scope	Page #
02h	Software Reset	Channel	page 72
04h	Hardware Reset	Global	page 72
06h	No Operation	Global	page 72
40/41h	Write/Read Transmit Time Slot	Channel	page 72
42/43h	Write/Read Receive Time Slot	Channel	page 73
44/45h	Write/Read Transmit and Receive Clock Slot and Transmit Clock Edge	Global	page 73
46/47h	Write/Read Device Configuration Register	Global	page 73
4A/4Bh	Write/Read Channel Enable & Operating Mode Register	Global	page 74
4D/4Fh	Read Signaling Register	Global	page 75
50/51h	Write/Read Voice Path Gains	Channel	page 77
52/53h	Write/Read Input/Output Data Register	Channel	page 77
54/55h	Write/Read Input/Output Direction Register	Channel	page 78
56/57h	Write/Read System State	Channel	page 78
5E/5Fh	Write/Read Device Mode Register	Global	page 79
60/61h	Write/Read Operating Functions	Channel	page 80
68/69h	Write/Read System State Configuration	Channel	page 81
6C/6Dh	Write/Read Interrupt Mask Register	Global	page 82
70/71h	Write/Read Operating Conditions	Channel	page 82
73h	Read Revision and Product Code Number (RCN, PCN))	Global	page 83
80/81h	Write/Read GX Filter Coefficients	Channel	page 83
82/83h	Write/Read GR Filter Coefficients	Channel	page 83
86/87h	Write/Read B Filter FIR Coefficients	Channel	page 84
88/89h	Write/Read X Filter Coefficients	Channel	page 85
8A/8Bh	Write/Read R Filter Coefficients	Channel	page 86
96/97h	Write/Read B Filter IIR Coefficients	Channel	page 87
98/99h	Write/Read Z Filter FIR Coefficients	Channel	page 87
9A/9Bh	Write/Read Z Filter IIR Coefficients	Channel	page 87
A6/A7h	Write/Read Converter Configuration	Channel	page 88
C2/C3h	Write/Read Loop Supervision Parameters	Channel	page 90
C6/C7h	Write/Read DC Feed Parameters	Channel	page 90
CA/CBh	Write/Read Digital Impedance Scaling Network (DISN)	Channel	page 91
CDh	Read Transmit PCM/Test Data	Channel	page 91
CFh	Read Test Data FIFO	Channel	page 92
D0/D1h	Write/Read Metering Parameters	Channel	page 93
D2/D3h	Write/Read Signal Generator A, B and Bias Parameters	Channel	page 94
D4/D5h	Write/Read Signal Generator C and D Parameters	Channel	page 96
DE/DFh	Write/Read Signal Generator Control	Channel	page 97
E0/E1h	Write/Read Cadence Timer	Channel	page 98
E2/E3h	Write/Read Caller Identification Number Data	Channel	page 98
E4/E5h	Write/Read Switching Regulator Parameters	Global	page 99
E6/E7h	Write/Read Switching Regulator Control	Global	page 100
E8/E9h	Write/Read Battery Calibration Register	Channel	page 101
EA/EBh	Write/Read Caller Identification Number Parameters	Channel	page 102
EC/EDh	Write/Read Internal Configuration Register 1	Channel	page 103
EE/EFh	Write/Read Internal Configuration Register 2	Channel	page 103
F2/F3h	Write/Read Internal Configuration Register 3	Channel	page 103

Hex*	Description	Scope	Page #
F4/F5h	Write/Read Internal Configuration Register 4	Channel	page 103
FA/FBh	Write/Read Internal Configuration Register 5	Channel	page 103
FC/FDh	Write/Read DC Calibration Register	Channel	page 104

Notes: All codes not listed are reserved by Microsemi and should not be used.

10.4 Detailed Descriptions Of Commands

This section details each command used by the Le88266/286 device. The command is shown, along with the format of any additional data bytes that follow. Unused bits are indicated by "RSVD"; 0's should be written to these bits (unless otherwise noted), but 0's are not guaranteed when they are read.

In all commands:

$R/\overline{W} = 0$: Write

$R/\overline{W} = 1$: Read

*Default field values are marked by an asterisk. A hardware reset forces the default values.

02h Software Reset

Command	D ₇	D ₆	D ₅	D ₄	D ₃	D ₂	D ₁	D ₀
W: 02h	0	0	0	0	0	0	1	0

This command only operates on the channels selected by the Channel Enable Register and it does not change clock slots, time slots or global chip parameters. The selected channels will be put into the Disconnect state as a result of a Software reset unless that channel is in the Shutdown state in which case it will stay in the Shutdown state.

04h Hardware Reset

Command	D ₇	D ₆	D ₅	D ₄	D ₃	D ₂	D ₁	D ₀
W: 04h	0	0	0	0	0	1	0	0

Hardware reset is equivalent to pulling the \overline{RST} pin on the device Low.

This command does not depend on the state of the Channel Enable Register. A Hardware reset will put all channels into the Shutdown state.

Notes:

The action of a hardware reset is described in the section on operating the Le88266/286 device.

06h No Operation

Command	D ₇	D ₆	D ₅	D ₄	D ₃	D ₂	D ₁	D ₀
W: 06h	0	0	0	0	0	1	1	0

40/41h Write/Read Transmit Time Slot

Command	D ₇	D ₆	D ₅	D ₄	D ₃	D ₂	D ₁	D ₀
W: 40h R: 41h	0	1	0	0	0	0	0	R/\overline{W}
I/O Data	RSVD	TTS6	TTS5	TTS4	TTS3	TTS2	TTS1	TTS0

TTS[6:0]: Transmit Time Slot

0–127: Time Slot Number (TTS0 is LSB, TTS6 is MSB)

This command applies to PCM mode only. Its contents are ignored in GCI mode.

Power Up and Hardware Reset (\overline{RST}) Value = 00h for Channel 1.

Power Up and Hardware Reset (\overline{RST}) Value = 01h for Channel 2.

42/43h Write/Read Receive Time Slot

Command	D ₇	D ₆	D ₅	D ₄	D ₃	D ₂	D ₁	D ₀
W: 42h R: 43h	0	1	0	0	0	0	1	R/W
I/O Data	RSVD	RTS6	RTS5	RTS4	RTS3	RTS2	RTS1	RTS0

RTS[6:0]: Receive Time Slot
 0–127: Time Slot Number (RTS0 is LSB, RTS6 is MSB)

This command applies to PCM mode only. Its contents are ignored in GCI mode.

Power Up and Hardware Reset ($\overline{\text{RST}}$) Value = 00h for Channel 1.

Power Up and Hardware Reset ($\overline{\text{RST}}$) Value = 01h for Channel 2.

44/45h Write/Read Transmit and Receive Clock Slot and Transmit Clock Edge

Command	D ₇	D ₆	D ₅	D ₄	D ₃	D ₂	D ₁	D ₀
W: 44h R: 45h	0	1	0	0	0	1	0	R/W
I/O Data	RSVD	XE	RCS2	RCS1	RCS0	TCS2	TCS1	TCS0

XE Transmit Edge
 0*: Transmit data changes on negative edge of PCLK
 1: Transmit data changes on positive edge of PCLK

RCS[2:0]: Receive Clock Slot
 0*–7: Receive Clock Slot number

TCS[2:0]: Transmit Clock Slot
 0*–7: Transmit Clock Slot number

This command does not depend on the state of the Channel Enable Register.
 This command applies to PCM mode only. Its contents are ignored in GCI mode.

*Power Up and Hardware Reset ($\overline{\text{RST}}$) Value = 00h.

46/47h Write/Read Device Configuration Register

Command	D ₇	D ₆	D ₅	D ₄	D ₃	D ₂	D ₁	D ₀
W: 46h R: 47h	0	1	0	0	0	1	1	R/W
I/O Data	INTM	RSVD	SMODE	RSVD	CSEL3	CSEL2	CSEL1	CSEL0

RSVD: Reserved for future use. Always write as 0, but 0 is not guaranteed when read.

INTM: Interrupt Mode
 0: CMOS-compatible output
 1*: Open drain output

SMODE: PCM Signaling Mode
 0*: No signaling on PCM highway
 1: Signaling on PCM highway

The PCM clock frequency can be selected by CSEL. The PCLK frequency selection affects all channels.

CSEL[3:0]:	PCM Clock Frequency
0000	1.536 MHz
0001	1.544 MHz
0010	2.048 MHz
0011	1.024 MHz
0100	3.072 MHz
0101	3.088 MHz
0110	4.096 MHz
0111	Reserved
1000	6.144 MHz
1001	6.176 MHz
1010*	8.192 MHz
1011	Reserved
1100	Reserved
1101	Reserved
1110	Reserved
1111	Reserved

This command does not depend on the state of the Channel Enable Register.
 This command applies to PCM mode only. Its contents are ignored in GCI mode.

In the absence of external PCLK, the on chip master clock will slow down to it's minimum operating frequency which will be in the range of 1/5 - 1/2 of its normal operating frequency. If the ACFS bit is reset in command [68/69h Write/Read System State Configuration, on page 81](#) then this enables a low power system standby state to be implemented where supervision functions are still operational and interrupts can be generated in the absence of any system clocks.

* Power Up and Hardware Reset ($\overline{\text{RST}}$) Value = 8Ah.

4A/4Bh Write/Read Channel Enable and Operating Mode Register

Command	D ₇	D ₆	D ₅	D ₄	D ₃	D ₂	D ₁	D ₀
W: 4Ah R: 4Bh	0	1	0	0	1	0	1	R/W
I/O Data	RSVD	RSVD	WBAND	RSVD	RSVD	RSVD	EC2	EC1

RSVD: Reserved for future use. Always write as 0, but 0 is not guaranteed when read.

WBAND: Wideband Codec Mode (Global Parameter)

0*: Normal Codec Mode. The codec has a 3.4 kHz bandwidth.

1: Wideband Codec Mode. The codec has a 7.0 kHz bandwidth.

EC2: Channel Enable 2

0: Disabled, channel 2 cannot receive commands

1*: Enabled, channel 2 can receive commands

EC1: Channel Enable 1

0: Disabled, channel 1 cannot receive commands

1*: Enabled, channel 1 can receive commands

* Power Up and Hardware Reset ($\overline{\text{RST}}$) Value = 03h.

4D/4Fh Read Signaling Register

This register reads signaling data with (4F) or without (4D) clearing any corresponding interrupt.

Command	D ₇	D ₆	D ₅	D ₄	D ₃	D ₂	D ₁	D ₀
R: 4Dh R: 4Fh	0	1	0	0	1	1	x	1
I/O Data Byte 1	CFAIL	OCALMY	TEMPA ₁	IO2 ₁	CAD ₁	CID ₁	GNK ₁	HOOK ₁
I/O Data Byte 2	DAT	OCALMZ	TEMPA ₂	IO2 ₂	CAD ₂	CID ₂	GNK ₂	HOOK ₂

The read without clearing interrupt command (4D) allows signaling bits that are masked (see [6C/6Dh Write/Read Interrupt Mask Register, on page 82](#)) to be monitored via polling the signaling register, while other bits that are unmasked are serviced in response to interrupts.

An interrupt is generated by pulling the $\overline{\text{INT}}$ pin low, or setting the SLCX bit in the upstream GCI SC channel, whenever any unmasked bit in the signaling register changes. There are two types of interrupt:

Type A interrupts are generated on both edge transitions and present the current status of the signal. When the signal state changes, the new state is locked in the signaling register, and an interrupt is generated. When the interrupt is cleared by reading the status in the signaling register (4Fh), the status corresponding to the interrupt is not necessarily cleared. A new interrupt will be generated only when a new change occurs.

CFAIL, OCALMY, OCALMZ, TEMPA_i, IO2_i, GNK_i, and HOOK_i are type A interrupts

Type B interrupts are generated when a specific event occurs. The corresponding signal is set to 1 and an interrupt is generated. When the read signaling register and clear interrupt (4Fh) command is issued, the interrupt is cleared and the signal is reset.

CAD_i and CID_i are type B interrupts.

Other status bits may change while an interrupt is pending. In this case, an additional interrupt is not generated if the new status is reported when the register is read. If the bit that caused the original interrupt has changed after it was latched in the signaling register but before the interrupt was cleared, the latched value will be read and a new interrupt with the new value (which will be latched) will be generated immediately after the interrupt is cleared.

The behavior of the various signals in this register depends on the contents of [C2/C3h Write/Read Loop Supervision Parameters, on page 90](#) where thresholds and debounce periods are set.

This command does not depend on the state of the Channel Enable register

DAT: Converter data.

0: No new data is available in [CDh Read Transmit PCM/Test Data, on page 91](#)

1: New data is available in [CDh Read Transmit PCM/Test Data, on page 91](#)

When unmasked by the ATI bit in the [A6/A7h Write/Read Converter Configuration, on page 88](#) the DAT interrupt will be asserted at the time new data is ready to be read from [CDh Read Transmit PCM/Test Data, on page 91](#). The interrupt pin is returned to a high level after 54 μsec (26 μs in wideband mode). When the ATI bit is masked the DAT status is not reported.

CFAIL: Clock Fail

0: The internal clock is synchronized to frame sync.

1: The internal clock is not synchronized to frame sync.

When clock fail is set, the data path is cleared for all channels.

OCALMY: Switching regulator Y over-voltage / current indicator.

0*: Switching Regulator Y working properly.

1: Switching regulator Y has an over-voltage / current fault.

The OCALMY bit is an indicator of an over-voltage at the switcher output (if SWOVP is set) or continuing over-current condition at the SWISY pin. This indicates to the user's system that a fault in switching regulator Y is probably occurring. The Y switcher is automatically shut off when an OCALMY interrupt is generated. The system states of the various channels are not reset and the user must take appropriate action based on the channel's state and the battery currently being used.

- OCALMZ: Switching regulator Z over current indicator.
- 0*: Switching Regulator Z working properly.
- 1: Switching regulator Z has an over-voltage / current fault.

The OCALMZ bit is an indicator of an over-voltage at the switcher output (if SWOVP is set) or continuing over-current condition at the SWISZ pin. This indicates to the user's system that a fault in switching regulator Z is probably occurring. The Z switcher is automatically shut off when an OCALMZ interrupt is generated. The system states of the various channels are not reset and the user must take appropriate action based on the channel's state and the battery currently being used.

- TEMPA: Thermal Fault Alarm
- 0*: High voltage line driver within safe operating temperature region
- 1: High voltage line driver at unsafe operating temperature and in thermal shutdown.

This bit is not updated when the system is in disconnect.

- IO2: Input 2 Status. The input value at IO2₁ or IO2₂
- 0: IO_{2i} input is low
- 1: IO_{2i} input is high

- CAD: Cadencer status when masked or interrupt if unmasked
- 0: Cadence timer is in the programmed on period (masked)
- 1: Cadence timer is in the programmed off period (masked)
- 0: Cadence interrupt has not occurred (unmasked).
- 1: Cadence interrupt has occurred (unmasked)
Cadencer has completed the programmed on period

- CID: Caller ID Buffer Ready
- 0: The CID buffer is full
- 1*: The CID buffer is ready
If unmasked, an interrupt is only generated when the CID buffer becomes ready

- GNK: Ground-key or Ground Fault detection.
- 0: No Ground Key (Longitudinal current less than TGK for longer than DGNK)
- 1: Ground Key detected (Longitudinal current greater than TGK for longer than DGNK)

- HOOK: Hook switch, Ground Start or Ring Trip event
- 0: On hook
- 1: Off hook

This bit signals events based on the system state illustrated in the table below.

State	Hook Interrupt Event
Active	On hook (Metallic current less than TSH for longer than DSH) Off hook (Metallic current greater than TSH for longer than DSH)
Tip Open	On hook (Metallic current less than TSH for longer than DSH) Off hook (Metallic current greater than TSH for longer than DSH)
Ring Open	On hook (Metallic current less than TSH for longer than DSH) Off hook (Metallic current greater than TSH for longer than DSH)
Balanced Ringing	On hook (Metallic current less than RTTH for two ring periods) Off hook (Metallic current greater than RTTH for two ring periods)

* Power Up and Hardware Reset ($\overline{\text{RST}}$) Value = 0000

50/51h Write/Read Voice Path Gains

Command	D ₇	D ₆	D ₅	D ₄	D ₃	D ₂	D ₁	D ₀
W: 50h R: 51h	0	1	0	1	0	0	0	R/W
I/O Data	RSVD	AX	AR1	AR0	DRL	RSVD	RSVD	RSVD

RSVD: Reserved for future use. Always write as 0, but 0 is not guaranteed when read.

AX: Transmit Analog Gain

0*: 0 dB gain
1: 6.02 dB gain

AR[1:0]: Receive Analog Loss

00*: 0 dB loss
01: 6.02 dB loss
10: 6.02 dB gain
11: RSVD

DRL: Digital Receive Loss. This mode is used in high current metering applications in combination with the 6.02 dB AR gain.

0*: No digital receive loss
1: A 6.02 dB loss is inserted in the voice receive path.

*Power Up and Hardware Reset ($\overline{\text{RST}}$) Value = 00h.

52/53h Write/Read Input/Output Data Register

Command	D ₇	D ₆	D ₅	D ₄	D ₃	D ₂	D ₁	D ₀
W: 52h R: 53h	0	1	0	1	0	0	1	R/W
I/O Data	RSVD	RSVD	RSVD	RSVD	RSVD	RSVD	IO2	IO1

RSVD Reserved for future use. Always write as 0, but 0 is not guaranteed when read.

IO1-IO2: Value at general purpose IO pins.

This register provides both data input and data output functions per channel depending on the setting of the corresponding IOD bits in [54/55h Write/Read Input/Output Direction Register](#). The data written appears latched on the I/O pin. In input mode, the logic state of the I/O pin is read. In output mode, the state of the I/O pin is read. A logic 1 written to the data register will cause the output to be logic 1.

54/55h Write/Read Input/Output Direction Register

Command	D ₇	D ₆	D ₅	D ₄	D ₃	D ₂	D ₁	D ₀
W: 54h R: 55h	0	1	0	1	0	1	0	R/W
I/O Data	RSVD	RSVD	RSVD	RSVD	RSVD	IOD2	RSVD	IOD1

RSVD: Reserved for future use. Always write as 0, but 0 is not guaranteed when read.
 IOD1-2: Direction of the IO1-2 pins (input or output)
 0*: IOx is an input
 1: IOx is an output

*Power Up and Hardware Reset (RST) Value = 00h

56/57h Write/Read System State

Command	D ₇	D ₆	D ₅	D ₄	D ₃	D ₂	D ₁	D ₀
W: 56h R: 57h	0	1	0	1	0	1	1	R/W
I/O Data	REX	METR	ACT	POLNR	SS3	SS2	SS1	SS0

REX: Ringing Status. This bit is read-only. Writes to this bit have no effect.
 0*: System is not in ring exit state.
 1: System is in ring exit or ringing state.
 When the system is in ringing and the user exits to a new state, the state register will reflect the new state that was last written by the user. However, the system may not change immediately to the new state, but may wait for a zero cross, in order to minimize line transients. During this period, REX will be 1 indicating the system is waiting for a zero cross. REX will also be 1 during ringing.

METR: Metering
 0*: Metering off
 1: Metering on. Metering will stay on for the duration specified in the MTRDR parameter of command [D0/D1h Write/Read Metering Parameters, on page 93](#) and METR will be reset to zero at the end of this time, terminating the meter pulse.

ACT: Activate Codec
 0*: Codec deactivated
 1: Codec Activated

No valid PCM data is transmitted until after the third FS pulse is received after the ACT bit is set.

POLNR: Normal or Reverse Polarity feed
 0*: Normal Polarity feed - TIPD more positive than RINGD
 1: Reverse Polarity feed - RINGD more positive than TIPD

SS[3:0]: System State is defined by the table below. These states can be switched between automatically by the Le88266/286 device if the ASSC bit is set. The table lists the default values of the states when the ASSC bit is set. Modifying other bits in this register will subsequently alter these states. Writing a new value to SS will change the system state.

SS3	SS2	SS1	SS0	Mode
0	0	0	0	Disconnect
0	0	0	1	Tip Open
0	0	1	0	Ring Open
0	0	1	1	Active Low Battery
0	1	0	0	Idle
0	1	0	1	RSVD
0	1	1	0	RSVD
0	1	1	1	Balanced Ringing
1	0	0	0	Low Gain
1	0	0	1	RSVD
1	0	1	0	Unbalanced Ringing
1	0	1	1	Active Mid Battery
1	1	0	0	RSVD
1	1	0	1	RSVD
1	1	1	0	RSVD
1*	1*	1*	1*	Shutdown

Notes:

- Where there is a conflict on a write to this register between the System State (SS) and the other bits, the other bits take precedence.
- Ringings uses signal generator A and the bias parameter to generate the ringing waveform.

Power Up and Hardware Reset ($\overline{\text{RST}}$) Value = 0Fh

5E/5Fh Write/Read Device Mode Register

Command	D ₇	D ₆	D ₅	D ₄	D ₃	D ₂	D ₁	D ₀
W: 68h R: 69h	0	1	1	0	1	0	0	$\overline{\text{R/W}}$
I/O Data	RSVD	RSVD	RSVD	RSVD	RSVD	RSVD	CBS	TDIM

RSVD: Reserved for future use. Always write as 0, but 0 is not guaranteed when read.

CBS: Channel Buffer Select
This bit only has significance when TDIM is set.

0*: The data reflected in the test data register and the test data buffer comes from channel 1. The interrupt refers to channel 1 data.

1: The data reflected in the test data register and the test data buffer comes from channel 2. The interrupt refers to channel 2 data.

TDIM: Test Data Interrupt Mode

0*: DAT status interrupt behaves as described in command [CDh Read Transmit PCM/Test Data, on page 91](#).

The interrupt is generated after each new sample. The data rate set by the DRAT field in the Converter Configuration Register affects the data rate written to the PCM/Test Data register, the data buffer, and the PCM highway.

- 1: DAT status interrupt behaves as described in command [CFh Read Test Data Buffer, on page 92](#).
 This bit changes the way the test data interrupt works. By default the interrupt is generated after each new sample. This is useful when reading a single sample from the Transmit Data Register. If this bit is set to 1, the interrupt indicates that the Test data buffer has data in it. The data rate set by the DRAT field in the Converter Configuration Register affects only the data rate written to the PCM/Test Data register and the data buffer. The PCM highway data is output at the WBAND rate.

*Power Up and Hardware Reset ($\overline{\text{RST}}$) Value = 00

60/61h Write/Read Operating Functions

Command	D ₇	D ₆	D ₅	D ₄	D ₃	D ₂	D ₁	D ₀
W: 60h R: 61h	0	1	1	0	0	0	0	R/W
I/O Data	C/L	A/μ	EGR	EGX	EX	ER	EZ	EB

- C/L: Linear Code
 - 0*: Compressed coding
 - 1: Linear coding
- A/μ: A-law or μ-law
 - 0*: A-law coding
 - 1: μ-law coding
- EGR: GR Filter
 - 0*: Default GR filter enabled
 - 1: Programmed GR filter enabled
- EGX: GX Filter
 - 0*: Default GX filter enabled
 - 1: Programmed GX filter enabled
- EX: X Filter
 - 0*: Default X filter enabled
 - 1: Programmed X filter enabled
- ER: R Filter
 - 0*: Default R filter enabled
 - 1: Programmed R filter enabled
- EZ: Z Filter
 - 0*: Default Z filter enabled
 - 1: Programmed Z filter enabled
- EB: B Filter
 - 0*: Default B filter enabled
 - 1: Programmed B filter enabled

*Power Up and Hardware Reset ($\overline{\text{RST}}$) Value = 00h.

68/69h Write/Read System State Configuration

Command	D ₇	D ₆	D ₅	D ₄	D ₃	D ₂	D ₁	D ₀
W: 68h R: 69h	0	1	1	0	1	0	0	R/W
I/O Data	RSVD	RSVD	ACFS	ATFS	ZXR	SPR	ASSC	ABAT

- RSVD: Reserved for future use. Always write as 0, but 0 is not guaranteed when read.
- ACFS: Automatic Clock Fail Switching
- 0: Automatic Clock Fail switching disabled
- 1*: Automatic Clock Fail switching enabled
- When a Clock Fail alarm is detected and persists for between 0.5 ms and 3 ms the channel will switch to the Shutdown state.
- ATFS: Automatic Thermal Fault Switching
- 0*: Automatic thermal fault switching disabled
- 1: Automatic thermal fault switching enabled
- The channel will switch to the Disconnect state when a high voltage line driver thermal fault alarm is detected.
- See TEMPFA bit description in command [4D/4Fh Read Signaling Register, on page 75](#).
- ZXR: Zero Cross Ringing Entry/Exit
- 0*: System will enter and exit the Ringing State smoothly by waiting for zero cross between the ringing waveform and the DC Tip-Ring voltage. This ensures a smooth transition between states and gives the switching regulator time to rise to an appropriate ringing voltage on ring entry.
- 1: System will enter and exit ringing immediately according to command [56/57h Write/Read System State, on page 78](#).
- SPR: Smooth Polarity Reversal
- 0*: Polarity reversals will be abrupt.
- 1: Polarity reversals will be smooth.
- ASSC: Automatic System State Control
- 0*: Automatic system state switching enabled
- System State will change due to the following supervision stimuli:
- Hook in Idle will cause a transition to Active.
 - Hook due to ring trip will cause a transition from Ringing to Active
 - Hook due to ground start in Tip or Ring Open will cause a transition to Active
- In all three cases, the resulting line polarity is defined by the POLNR bit
- ACT will be updated appropriately
- 1: Automatic system state switching disabled
- State changes only occur as a result of user commands
- ABAT: Auto battery switching
- 0*: Automatic battery switching enabled.
- System will automatically switch between Active States to maintain the lowest battery needed to support Tip - Ring Voltage.
- 1: User selected Active State battery is selected when user writes Mid or Low battery state. However, if the Low Battery voltage is not sufficient to support the tipping voltage, mid battery will remain selected. If the ASSC bit is not set (automatic state switching enabled) and ABAT = 1 (no auto battery switching), the user must write the correct Active battery state after an off hook transition.

*Power Up and Hardware Reset (\overline{RST}) Value =20h.

6C/6Dh Write/Read Interrupt Mask Register

Command	D ₇	D ₆	D ₅	D ₄	D ₃	D ₂	D ₁	D ₀
W: 6Ch R: 6Dh	0	1	1	0	1	1	0	R/W
I/O Data Byte 1	MCFAIL	MOCALMY	MTEMPA ₁	MIO2 ₁	MCAD ₁	MCID ₁	MGNK ₁	MHOOK ₁
I/O Data Byte 2	RSVD	MOCALMZ	MTEMPA ₂	MIO2 ₂	MCAD ₂	MCID ₂	MGNK ₂	MHOOK ₂

In the MPI mode, this register defines which signals can generate interrupts and be latched in the [4D/4Fh Read Signaling Register, on page 75](#). In GCI mode, this register defines which signals can cause the SLCX bit to be set in the upstream signalling channel. In GCI mode, MGNK_i, MHOOK_i should always be masked.

RSVD: Reserved for future use. Always write as 1, but 1 is not guaranteed when read.

Mx: Mask Interrupt/Signaling bits

0: Signal is NOT masked, change will generate an interrupt or set SLCX

1*: Signal is masked, a change does not cause an interrupt or set SLCX

This command does not depend on the state of the Channel Enable Register.

*Power Up and Hardware Reset (\overline{RST}) Value = FFFFh.

70/71h Write/Read Operating Conditions

Command	D ₇	D ₆	D ₅	D ₄	D ₃	D ₂	D ₁	D ₀
W: 70h R: 71h	0	1	1	1	0	0	0	R/W
I/O Data	CTP	CRP	HPF	LRG	RSVD	ILB	RSVD	TON

RSVD: Reserved for future use. Always write as 0, but 0 is not guaranteed when read.

CTP: Cutoff Transmit Path

0*: Transmit path connected

1: Transmit path cut off

CRP: Cutoff Receive Path

0*: Receive path connected

1: Receive path cutoff

HPF: High Pass Filter

0*: Transmit Highpass filters enabled

1: Transmit Highpass filters disabled

LRG: Lower Receive Gain

0*: 6-dB loss not inserted

1: 6-dB loss inserted

ILB: Interface Loopback

0*: TSA loopback disabled

1: TSA loopback enabled

TON: 1 kHz Receive Tone

0*: 1 kHz receive tone off

1: 1 kHz receive tone on

This tone is 2 Khz in wideband mode.

*Power Up and Hardware Reset (\overline{RST}) Value = 00h.

73h Read Revision and Product Code Number (RCN,PCN)

Command	D ₇	D ₆	D ₅	D ₄	D ₃	D ₂	D ₁	D ₀
R: 73h	0	1	1	1	0	0	1	1
Output Data Byte 1	RCN7	RCN6	RCN5	RCN4	RCN3	RCN2	RCN1	RCN0
Output Data Byte 2	PCN7	PCN6	PCN5	PCN4	PCN3	PCN2	PCN1	PCN0

This command returns an 8-bit number (RCN) describing the revision number of the device and an 8-bit product code number indicating the VE880 series part number.

The revision code (RCN) of the Le88266/286 JA is 04h.

PCN: Product Code Number

B3h	Le88266 device
B4h	Le88286TQC device
B7h	Le88286DLC device

This command does not depend on the state of the Channel Enable Register.

80/81h Write/Read GX Filter Coefficients

Command	D ₇	D ₆	D ₅	D ₄	D ₃	D ₂	D ₁	D ₀
W: 80h R: 81h	1	0	0	0	0	0	0	R/W
I/O Data Byte 1	C40	m40			C30	m30		
I/O Data Byte 2	C20	m20			C10	m10		

C_{xy} = 0 or 1 in the command above corresponds to C_{xy} = +1 or -1, respectively, in the equation below.

The coefficient for the GX filter is defined as:

$$H_{GX} = 1 + (C10 \cdot 2^{-m10} \{1 + C20 \cdot 2^{-m20} [1 + C30 \cdot 2^{-m30} (1 + C40 \cdot 2^{-m40})]\})$$

*Power Up and Hardware Reset (\overline{RST}) Values = 0190h ($H_{GX} = 1$ (0 dB)).

Notes:

The default value is contained in a ROM register separate from the programmable coefficient RAM and the ROM register's default value can not be read. There is a filter enable bit in Operating Functions register to switch between the default and programmed values.

82/83h Write/Read GR Filter Coefficients

Command	D ₇	D ₆	D ₅	D ₄	D ₃	D ₂	D ₁	D ₀
W: 82h R: 83h	1	0	0	0	0	0	1	R/W
I/O Data Byte 1	C40	m40			C30	m30		
I/O Data Byte 2	C20	m20			C10	m10		

C_{xy} = 0 or 1 in the command above corresponds to C_{xy} = +1 or -1, respectively, in the equation below.

The coefficient for the GR filter is defined as:

$$H_{GR} = C10 \cdot 2^{-m10} \{1 + C20 \cdot 2^{-m20} [1 + C30 \cdot 2^{-m30} (1 + C40 \cdot 2^{-m40})]\}$$

*Power Up and Hardware Reset (\overline{RST}) Values = 0111h ($H_{GR} = 1$ (0 dB)).

See note under Command 80/81h on page 83

86/87h Write/Read B Filter FIR Coefficients

Command	D ₇	D ₆	D ₅	D ₄	D ₃	D ₂	D ₁	D ₀
W: 86h R: 87h	1	0	0	0	0	1	1	R/W
I/O Input Data Byte 1	C32	m32			C22	m22		
I/O Input Data Byte 2	C12	m12			C33	m33		
I/O Input Data Byte 3	C23	m23			C13	m13		
I/O Input Data Byte 4	C34	m34			C24	m24		
I/O Input Data Byte 5	C14	m14			C35	m35		
I/O Input Data Byte 6	C25	m25			C15	m15		
I/O Input Data Byte 7	C36	m36			C26	m26		
I/O Input Data Byte 8	C16	m16			C37	m37		
I/O Input Data Byte 9	C27	m27			C17	m17		
I/O Input Data Byte 10	C38	m38			C28	m28		
I/O Input Data Byte 11	C18	m18			C39	m39		
I/O Input Data Byte 12	C29	m29			C19	m19		
I/O Input Data Byte 13	C310	m310			C210	m210		
I/O Input Data Byte 14	C110	m110			RSVD	RSVD		

RSVD Reserved for future use. Always write as 0, but 0 is not guaranteed when read. C_{xy} = 0 or 1 in the command above corresponds to C_{xy} = +1 or -1, respectively, in the equation below. The Z-transform equation for the B filter is defined as:

$$H_B(z) = B_2 \cdot z^{-2} + \dots + B_9 \cdot z^{-9} + \frac{B_{10} \cdot z^{-10}}{1 - B_{11} \cdot z^{-1}}$$

Sample rate = 16 kHz

The coefficients for the FIR B section and the gain of the IIR B section are defined as:

For i = 2 to 10,

$$B_i = C1i \cdot 2^{-m1i} [1 + C2i \cdot 2^{-m2i} (1 + C3i \cdot 2^{-m3i})]$$

The feedback coefficient of the IIR B section is defined as:

$$B_{11} = C111 \cdot 2^{-m111} \{1 + C211 \cdot 2^{-m211} [1 + C311 \cdot 2^{-m311} (1 + C411 \cdot 2^{-m411})]\}$$

Refer to Command [96/97h Write/Read B Filter IIR Coefficients, on page 87](#) for programming of the B₁₁ coefficients.

*Power Up and Hardware Reset (RST) Values = 0900 9009 0090 0900 9009 0090 0900h

$$H_B(z) = 0$$

See note under Command 80/81h on page 83.

88/89h Write/Read X Filter Coefficients

Command	D ₇	D ₆	D ₅	D ₄	D ₃	D ₂	D ₁	D ₀
W: 88h R: 89h	1	0	0	0	1	0	0	R/W
I/O Input Data Byte 1	C40	m40			C30	m30		
I/O Input Data Byte 2	C20	m20			C10	m10		
I/O Input Data Byte 3	C41	m41			C31	m31		
I/O Input Data Byte 4	C21	m21			C11	m11		
I/O Input Data Byte 5	C42	m42			C32	m32		
I/O Input Data Byte 6	C22	m22			C12	m12		
I/O Input Data Byte 7	C43	m43			C33	m33		
I/O Input Data Byte 8	C23	m23			C13	m13		
I/O Input Data Byte 9	C44	m44			C34	m34		
I/O Input Data Byte 10	C24	m24			C14	m14		
I/O Input Data Byte 11	C45	m45			C35	m35		
I/O Input Data Byte 12	C25	m25			C15	m15		

C_{xy} = 0 or 1 in the command above corresponds to C_{xy} = +1 or -1, respectively, in the equation below.

The Z-transform equation for the X filter is defined as:

$$H_x(z) = x_0 + x_1 z^{-1} + x_2 z^{-2} + x_3 z^{-3} + x_4 z^{-4} + x_5 z^{-5}$$

Sample rate = 16 kHz

For i = 0 to 5, the coefficients for the X filter are defined as:

$$X_i = C1_i \cdot 2^{-m1_i} \{ 1 + C2_i \cdot 2^{-m2_i} [1 + C3_i \cdot 2^{-m3_i} (1 + C4_i \cdot 2^{-m4_i})] \}$$

*Power Up and Hardware Reset (\overline{RST}) Values = 0111 0190 0190 0190 0190 0190h

$$(H_x(z) = 1)$$

See note under Command 80/81h on page 83.

8A/8Bh Write/Read R Filter Coefficients

Command	D ₇	D ₆	D ₅	D ₄	D ₃	D ₂	D ₁	D ₀
W: 8Ah R: 8Bh	1	0	0	0	1	0	1	R/W
I/O Input Data Byte 1	C46	m46			C36	m36		
I/O Input Data Byte 2	C26	m26			C16	m16		
I/O Input Data Byte 3	C40	m40			C30	m30		
I/O Input Data Byte 4	C20	m20			C10	m10		
I/O Input Data Byte 5	C41	m41			C31	m31		
I/O Input Data Byte 6	C21	m21			C11	m11		
I/O Input Data Byte 7	C42	m42			C32	m32		
I/O Input Data Byte 8	C22	m22			C12	m12		
I/O Input Data Byte 9	C43	m43			C33	m33		
I/O Input Data Byte 10	C23	m23			C13	m13		
I/O Input Data Byte 11	C44	m44			C34	m34		
I/O Input Data Byte 12	C24	m24			C14	m14		
I/O Input Data Byte 13	C45	m45			C35	m35		
I/O Input Data Byte 14	C25	m25			C15	m15		

Cxy = 0 or 1 in the command above corresponds to Cxy = +1 or -1, respectively, in the equation below.

$$HR = H_{IIR} \cdot H_{FIR}$$

The Z-transform equation for the IIR filter (RI) is defined as:

$$H_{IIR} = \frac{1 - z^{-1}}{1 - (R_6 \cdot z^{-1})}$$

Sample rate = 8 kHz

The coefficient for the IIR filter is defined as:

$$R_6 = C16 \cdot 2^{-m16} \{1 + C26 \cdot 2^{-m26} [1 + C36 \cdot 2^{-m36} (1 + C46 \cdot 2^{-m46})]\}$$

R6 should normally not be set to unity. If it is required to generate DC levels through the receive path from the PCM, the CRP bit ([70/71h Write/Read Operating Conditions, on page 82](#)) should be set 5ms before writing R6 to unity. The RTP bit can then be reset and DC or low frequency signals passed from the PCM.

The Z-transform equation for the FIR filter is defined as:

$$H_{FIR}(z) = R_0 + R_1z^{-1} + R_2z^{-2} + R_3z^{-3} + R_4z^{-4} + R_5z^{-5}$$

Sample rate = 16 kHz

For i = 0 to 5, the coefficients for the R2 filter are defined as:

$$R_i = C1i \cdot 2^{-m1i} \{1 + C2i \cdot 2^{-m2i} [1 + C3i \cdot 2^{-m3i} (1 + C4i \cdot 2^{-m4i})]\}$$

*Power Up and Hardware Reset (RST) Values = 2E01 0111 0190 0190 0190 0190 0190h

$$(H_{FIR}(z) = 1, R_6 = 0.9902)$$

See note under Command 80/81h on page 83.

96/97h Write/Read B Filter IIR Coefficients

Command	D ₇	D ₆	D ₅	D ₄	D ₃	D ₂	D ₁	D ₀
W: 96h R: 97h	1	0	0	1	0	1	1	R/W
I/O Data Byte 1	C411	m411			C311	m311		
I/O Data Byte 2	C211	m211			C111	m111		

This function is described in command [86/87h Write/Read B Filter FIR Coefficients, on page 84](#)

*Power Up and Hardware Reset ($\overline{\text{RST}}$) Values = 0190h ($B_{11} = 0$)

See note under Command 80/81h on page 83.

98/99h Write/Read Z Filter FIR Coefficients

Command	D ₇	D ₆	D ₅	D ₄	D ₃	D ₂	D ₁	D ₀
W: 98h R: 99h	1	0	0	1	1	0	0	R/W
I/O Data Byte 1	C40	m40			C30	m30		
I/O Data Byte 2	C20	m20			C10	m10		
I/O Data Byte 3	C41	m41			C31	m31		
I/O Data Byte 4	C21	m21			C11	m11		
I/O Data Byte 5	C42	m42			C32	m32		
I/O Data Byte 6	C22	m22			C12	m12		
I/O Data Byte 7	C43	m43			C33	m33		
I/O Data Byte 8	C23	m23			C13	m13		
I/O Data Byte 9	C44	m44			C34	m34		
I/O Data Byte 10	C24	m24			C14	m14		

This function is described in command [9A/9Bh Write/Read Z Filter IIR Coefficients, on page 87](#)

*Power Up and Hardware Reset ($\overline{\text{RST}}$) Values = 0190 0190 0190 0190 0190h

$$(H_Z(z) = 0)$$

9A/9Bh Write/Read Z Filter IIR Coefficients

Command	D ₇	D ₆	D ₅	D ₄	D ₃	D ₂	D ₁	D ₀
W: 9Ah R: 9Bh	1	0	0	1	1	0	1	R/W
I/O Data Byte 1	C45	m45			C35	m35		
I/O Data Byte 2	C25	m25			C15	m15		
I/O Data Byte 3	C26	m26			C16	m16		
I/O Data Byte 4	C47	m47			C37	m37		
I/O Data Byte 5	C27	m27			C17	m17		

C_{xy} = 0 or 1 in the command above corresponds to C_{xy} = +1 or -1, respectively, in the equation below.

The Z-transform equation for the Z filter is defined as:

$$H_z(z) = z_0 + z_1 \cdot z^{-1} + z_2 \cdot z^{-2} + z_3 \cdot z^{-3} + z_4 \cdot z^{-4} + \frac{z_5 \cdot z_6 \cdot z_7 \cdot z^{-1}}{1 - z_7 \cdot z^{-1}}$$

Sample rate = 32 kHz

For i = 0 to 5 and 7

$$z_i = C1i \cdot 2^{-m1i} \{ 1 + C2i \cdot 2^{-m2i} [1 + C3i \cdot 2^{-m3i} (1 + C4i \cdot 2^{-m4i})] \}$$

$$z_6 = C16 \cdot 2^{-m16} \{ 1 + C26 \cdot 2^{-m26} \}$$

*Power Up and Hardware Reset (\overline{RST}) Values = 0190 01 0190h

$$(H_z(z) = 0)$$

See note under Command 80/81h on page 83.

Notes:

Z_6 is used for IIR filter scaling only. Its value is typically greater than zero but less than or equal to one. The input to the IIR filter section is first increased by a gain of $1/Z_6$, improving dynamic range and avoiding truncation limitations through processing within this filter. The IIR filter output is then multiplied by Z_6 to normalize the overall gain. Z_5 is the actual IIR filter gain value defined by the programmed coefficients, but it also includes the initial $1/Z_6$ gain. The theoretical effective IIR gain, without the Z_6 gain and normalization, is actually Z_5/Z_6 .

A6/A7h Write/Read Converter Configuration

Command	D7	D6	D5	D4	D3	D2	D1	D0
W: A6 R: A7h	1	0	1	0	0	1	1	\overline{RW}
I/O Data	ATI	DRAT2	DRAT1	DRAT0	SEL3	SEL2	SEL1	SEL0

ATI: Arm Transmit PCM data Interrupt.
 0*: Transmit Data Ready interrupt disabled
 1: Transmit Data Ready interrupt enabled

When ATI is 1, the interrupt pin will go active when the transmit data becomes available in [CDh Read Transmit PCM/Test Data, on page 91](#). The interrupt will be cleared automatically after 54 μ s (26 μ s in wideband mode) (or when the data is read from the XDAT register). This interrupt indicates that data is available on both channels.

DRAT[2:0]: Data rate at which the converter data is updated.
 The sampled data is output on the PCM highway and in register [CDh Read Transmit PCM/Test Data, on page 91](#), as defined below. The ATI interrupt will also occur at this data rate if unmasked.

	Narrowband	Wideband
000*:	8 kHz	16kHz
001:	4 kHz	8kHz
010:	2 kHz	4kHz
011:	1 kHz	2kHz
100:	500 Hz	1kHz
101:	Reserved	Reserved
110:	Reserved	Reserved
111:	Reserved	Reserved

SEL[3:0]: This register selects the transmit path analog input source
 The bits SEL3 - SEL0 select which input is routed to the A/D converter and hence which measurement shows up at the PCM highway and in register [CDh](#)

[Read Transmit PCM/Test Data, on page 91](#). All unspecified codes are reserved. When selecting a new input source, wait at least 3 ms for the data to become stable.

SEL3	SEL2	SEL1	SEL0	Value written to measurement register	Operating Range ²	Scale
0*	0*	0*	0*	Tip - Ring Metallic AC coupled Voltage	-3.44 V to 3.44 V	105 μ V
0	0	0	1	Switcher/Battery input at SWY	-160 V to 0 V	-7.324 mV
0	0	1	0	Switcher/Battery input at SWZ	-160 V to 0 V	-7.324 mV
0	0	1	1	Switcher/Battery input at XB	-160 V to 0 V	-7.324 mV
0	1	0	0	Tip Voltage to ground	-240 V to 240 V	-7.324 mV
0	1	0	1	Ring Voltage to ground	-240 V to 240 V	-7.324 mV
0	1	1	0	Tip - Ring Metallic DC coupled Voltage	-240 V to 240 V	-7.324 mV
0	1	1	1	Tip - Ring Metallic Current - Ringing State	-115 mA to 115 mA	-3.52 μ A
0	1	1	1	Tip - Ring Metallic Current - DC Feed State	-57.7 mA to 57.7 mA	-1.76 μ A
0	1	1	1	Total Longitudinal Current - Low Gain State	-600 μ A to 600 μ A	-18.3 nA
1	0	0	0	Tip + Ring Longitudinal Current, LI = 0	-42 mA to 42 mA	1.3 μ A
1	0	0	0	Tip + Ring Longitudinal Current, LI = 1	-84 mA to 84 mA	2.6 μ A
1	0	0	0	Metallic Current - Low Gain State, LI = 0	-105 μ A to 105 μ A	3.20 nA
1	0	0	0	Metallic Current - Low Gain State, LI = 1	-210 μ A to 210 μ A	6.41 nA
1	0	0	1	Calibration Current (IREF)	-25 μ A to 25 μ A	2.27 nA
1	0	1	0	Voice DAC Analog Loopback	-3.44 V to 3.44 V	105 μ V
1	0	1	1	No connection - read ADC output offset 1 .	-3.44 V to 3.44 V	105 μ V
1	1	x	x	Reserved	RSVD	RSVD

Notes:

1. The ADC output offset is defined relative to the default metallic AC coupled tip-ring voltage.
2. Operating ranges assume the standard external application circuit component values are used.

The operating range values may be less than the full scale ranges of the output. The scale assumes:

Register [50/51h Write/Read Voice Path Gains, on page 77](#) = 00 h,

Register [60/61h Write/Read Operating Functions, on page 80](#) = 80 h,

Register [70/71h Write/Read Operating Conditions, on page 82](#) = 20 h and

Register [CA/CBh Write/Read Digital Impedance Scaling Network \(DISN\), on page 91](#) = 00 h.

Note that the SEL bit settings are overwritten when a system state change occurs. Wait 15 ms after the desired system state is selected before configuring the converter. It is also recommended that the ASSC bit in register [68/69h Write/Read System State Configuration, on page 81](#) be set when performing measurements to avoid unexpected state changes that would disrupt the measurement.

The voltage and current scales define the typical values and do not imply a specific accuracy for the measurement path and A/D converter. The absolute accuracy of the measurement paths can be found in the electrical specification section. To achieve the specified accuracies, the ADC offset voltage should first be read by selecting the 'No connection' option and subtracting this result from subsequent measurements. A full digital loop back from the digital input through the DAC to the ADC and back to the digital output is achieved by making the connection to the voice DAC. The nominal gain of this path is 0 dB.

For the battery inputs, Tip and Ring voltages, a negative voltage on the line reads as a positive value.

*Power Up and Hardware Reset (RST) Value = 00h

C2/C3h Write/Read Loop Supervision Parameters

Command	D7	D6	D5	D4	D3	D2	D1	D0
W: C2h R: C3h	1	1	0	0	0	0	1	R/W
I/O Data Byte 1	RSVD	RSVD	TGK2	TGK1	TGK0	TSH2	TSH1	TSH0
I/O Data Byte 2	DGK2	DGK1	DGK0	DSH4	DSH3	DSH2	DSH1	DSH0
I/O Data Byte 3	RTDCAC	RTTH6	RTTH5	RTTH4	RTTH3	RTTH2	RTTH1	RTTH0
I/O Data Byte 4	RSVD	RSVD	RSVD	ILR4	ILR3	ILR2	ILR1	ILR0

- RSVD Reserved for future use. Always write as 0, but 0 is not guaranteed when read.
- TGK[2:0]: Ground-key threshold; 0–42 mA, with a scale of 6 mA/step.
(default = 011b = 18mA)
- TSH[2:0]: Switch hook threshold 8 - 15mA with a scale of 1mA Ω/step
(default = 011b = 11mA)
- DGK[2:0]: Ground-key debounce; 0–28 ms, with a scale of 4 ms/step
(default = 100b = 16 ms)
- DSH[4:0]: Switch-hook debounce interval; 0–62 ms, with a scale of 2 ms/step
Debounce settings less than 12 ms are not recommended
(default = 00100b = 8 ms)
- RTDCAC: Ring Trip DC or AC.
 - 0: Use DC ring trip detection algorithm which requires DC bias.
 - 1*: Use AC ring trip detection algorithm which does not require DC bias.
- RTTH[6:0]: Ring trip threshold; 0 - 63.5 mA with a scale of 0.5 mA/step.
(default = 110011b = 25.5mA)
- ILR[4:0]: Ringing current limit; 50 - 112mA with a scale of 2 mA/step.
(default = 01110b = 78 mA)

*Power Up and Hardware Reset (\overline{RST}) Value = 1B84 B30Eh

C6/C7h Write/Read DC Feed Parameters

Command	D7	D6	D5	D4	D3	D2	D1	D0
W: C6h R: C7h	1	1	0	0	0	1	1	R/W
I/O Data Byte 1	RSVD	VOCSFT	LI	VOC2	VOC1	VOC0	VAS3	VAS2
I/O Data Byte 2	VAS1	VAS0	RSVD	ILA4	ILA3	ILA2	ILA1	ILA0

- RSVD Reserved for future use. Always write as 0, but 0 is not guaranteed when read.
- VOCSFT: VOC shift
 - 0*: VOC open circuit DC feed voltage. 36 - 57 V, with a step size of 3.0 V
 - 1: VOC open circuit DC feed voltage. 12 - 33 V, with a step size of 3.0 V
- LI: Longitudinal Impedance
 - 0*: Longitudinal Impedance set to 100 Ω/leg
 - 1: Longitudinal Impedance set to 50 Ω/leg
- VOC[2:0]: Open circuit DC feed voltage. 36 - 57 V, with a step size of 3.0 V, VOCSFT = 0
Open circuit DC feed voltage. 12 - 33 V, with a step size of 3.0 V, VOCSFT = 1
(default = 100b = 48.0 V)

VAS[3:0]: Battery Switching offset voltage: 1.5 - 7.125 V, with a step size of 0.375 V (default = 1000b = 4.5 V)

The device switches from VBM to VBL when the sensed Tip-Ring Feed voltage is less than $|VBL + ABSCAL + VAS + |Iloop| * 200 + bshv|$ for more than 2 ms, and from VBL to VBM when the sensed Tip-Ring Feed voltage is greater than $|VBL + ABSCAL + VAS + |Iloop| * 200|$ for more than 2 ms. For correct battery switching threshold setting, both switching regulator controllers must be enabled, even if they are not being used to generate battery voltages. Ensure the ZM and YM bits in [E6/E7h Write/Read Switching Regulator Control, on page 100](#) are non zero.

ILA[4:0]: Current Limit Active mode; 18–49 mA, with a step size of 1 mA (default = 01000b = 26 mA)

Power Up and Hardware Reset (\overline{RST}) Value = 1108h

CA/CBh Write/Read Digital Impedance Scaling Network (DISN)

Command	D ₇	D ₆	D ₅	D ₄	D ₃	D ₂	D ₁	D ₀
W: CAh R: CBh	1	1	0	0	1	0	1	R/W
I/O Data	DISN7	DISN6	DISN5	DISN4	DISN3	DISN2	DISN1	DISN0

DISN[7:0]: Digital Impedance scaling network two's complement gain value.
The DISN gain can be varied from -1.0 to 0.992 in steps of 0.0078. A value of 0 removes the DISN from the impedance loop.

*Power Up and Hardware Reset (\overline{RST}) Value = 00h

CDh Read Transmit PCM/Test Data

Command	D ₇	D ₆	D ₅	D ₄	D ₃	D ₂	D ₁	D ₀
R: CDh	1	1	0	0	1	1	0	1
Output Data Byte 1	XDAT15	XDAT14	XDAT13	XDAT12	XDAT11	XDAT10	XDAT9	XDAT8
Output Data Byte 2	XDAT7	XDAT6	XDAT5	XDAT4	XDAT3	XDAT2	XDAT1	XDAT0

This register will behave as described when the TDIM bit in [5E/5Fh Write/Read Device Mode Register, on page 79](#) is left in its default state (reset).

XDAT: Read signal Value.

XDAT[15:8] Contains A-law or μ -law transmit data in Companded mode.

XDAT[15:0] Contains upper and lower data bytes in Linear mode with sign in XDAT15.

XDAT can only be read from one channel at a time as selected by the EC register. If two channels or no channel are selected, the data for channel 1 will be returned.

In test mode, as defined by command [A6/A7h Write/Read Converter Configuration, on page 88](#), the A/D converter is connected either to the voice path (codec bypass), or to other signals as defined by the SEL bits. In this case the XDAT[0-15] bits indicate the measured value of the signal connected to the A/D converter in 1.15 format assuming linear mode is selected. The maximum values and scales are given in the chart. Negative Tip, Ring and battery voltages are reported as positive values.

This register input is sampled data at a rate set by DRAT in command [A6/A7h Write/Read Converter Configuration, on page 88](#) and the register is updated at the programmed data rate. A new measurement may be made by updating the converter configuration register. An interrupt can be generated and the DAT bit in [4D/4Fh Read Signaling Register, on page 75](#) is set every time this register is updated by setting the ATI bit in the same converter configuration register. The signal may be sampled by the user as fast as 8KSa/sec in this mode.

To get meaningful DC test data, the device should be configured as described in [A6/A7h Write/Read Converter Configuration, on page 88](#). This data will also be transmitted on the DXA pin unless the CTP bit is set.

While this register can be read in GCI mode, the monitor channel protocol only allows this data to be sampled at a slow rate. It is recommended that the compressed B channel data is read directly from the GCI bus in this mode.

CFh Read Test Data Buffer

Command	D ₇	D ₆	D ₅	D ₄	D ₃	D ₂	D ₁	D ₀
R: CFh	1	1	0	0	1	1	1	1
Output Data Byte 1	RSVD	LEN2	LEN1	LEN0	HK25	HK24	HK23	HK22
Output Data Byte 2	HK21	HK20	HK15	HK14	HK13	HK12	HK11	HK10
Output Data Byte 3	DAT1 ₁₅	DAT1 ₁₄	DAT1 ₁₃	DAT1 ₁₂	DAT1 ₁₁	DAT1 ₁₀	DAT1 ₉	DAT1 ₈
Output Data Byte 4	DAT1 ₇	DAT1 ₆	DAT1 ₅	DAT1 ₄	DAT1 ₃	DAT1 ₂	DAT1 ₁	DAT1 ₀
Output Data Byte 5	DAT2 ₁₅	DAT2 ₁₄	DAT2 ₁₃	DAT2 ₁₂	DAT2 ₁₁	DAT2 ₁₀	DAT2 ₉	DAT2 ₈
Output Data Byte 6	DAT2 ₇	DAT2 ₆	DAT2 ₅	DAT2 ₄	DAT2 ₃	DAT2 ₂	DAT2 ₁	DAT2 ₀
Output Data Byte 7	DAT3 ₁₅	DAT3 ₁₄	DAT3 ₁₃	DAT3 ₁₂	DAT3 ₁₁	DAT3 ₁₀	DAT3 ₉	DAT3 ₈
Output Data Byte 8	DAT3 ₇	DAT3 ₆	DAT3 ₅	DAT3 ₄	DAT3 ₃	DAT3 ₂	DAT3 ₁	DAT3 ₀
Output Data Byte 9	DAT4 ₁₅	DAT4 ₁₄	DAT4 ₁₃	DAT4 ₁₂	DAT4 ₁₁	DAT4 ₁₀	DAT4 ₉	DAT4 ₈
Output Data Byte 10	DAT4 ₇	DAT4 ₆	DAT4 ₅	DAT4 ₄	DAT4 ₃	DAT4 ₂	DAT4 ₁	DAT4 ₀
Output Data Byte 11	DAT5 ₁₅	DAT5 ₁₄	DAT5 ₁₃	DAT5 ₁₂	DAT5 ₁₁	DAT5 ₁₀	DAT5 ₉	DAT5 ₈
Output Data Byte 12	DAT5 ₇	DAT5 ₆	DAT5 ₅	DAT5 ₄	DAT5 ₃	DAT5 ₂	DAT5 ₁	DAT5 ₀
Output Data Byte 13	DAT6 ₁₅	DAT6 ₁₄	DAT6 ₁₃	DAT6 ₁₂	DAT6 ₁₁	DAT6 ₁₀	DAT6 ₉	DAT6 ₈
Output Data Byte 14	DAT6 ₇	DAT6 ₆	DAT6 ₅	DAT6 ₄	DAT6 ₃	DAT6 ₂	DAT6 ₁	DAT6 ₀

This register will behave as described when the TDIM bit in [5E/5Fh Write/Read Device Mode Register, on page 79](#) is set and the ACT bit of the channel selected by the CBS bit is set.

- RSVD Reserved for future use. Always write as 0, but 0 is not guaranteed when read.
- LEN[2:0]: Number of valid PCM data words and Hook bits stored in the FIFOs.
Values from 0 to 6 indicate the number of new DAT words and HK bits collected since this register was last read.
A value of 7 indicates that the buffers have overflowed and that samples have been discarded.
This field is reset to zero when the register is read. An interrupt can be generated and the DAT bit in [4D/4Fh Read Signaling Register, on page 75](#) set when the first new sample is loaded into the FIFO and the length field increments to 001b if the ATI bit is set.
- HK1[5:0]: Hook Bit Channel 1 FIFO
This FIFO stores the status of the debounced Hook Switch Detector output. The LEN field defines the number of valid detector samples stored in the 1 bit wide FIFO.
- HK2[5:0]: Hook Bit Channel 2 FIFO
This FIFO stores the status of the debounced Hook Switch Detector output. The LEN field defines the number of valid detector samples stored in the 1 bit wide FIFO.
- DAT1-6: PCM Sample FIFO data.

DATn[15:8] Contains A-law or μ -law transmit data in Companded mode.
 DATn[15:0] Contains upper and lower data bytes in Linear mode with sign in DATn15.

The DATn FIFO can only be read from one channel at a time as selected by the CDS bit in the [5E/5Fh Write/Read Device Mode Register, on page 79](#).

In test mode, as defined by command [A6/A7h Write/Read Converter Configuration, on page 88](#), the A/D converter is connected either to the voice path (codec bypass), or to other signals as defined by the SEL bits. In this case the DATn words indicate the measured value of the signal connected to the A/D converter in 1.15 format assuming linear mode is selected. The maximum values and scales are given in the chart. Negative Tip, Ring and battery voltages are reported as positive values.

The DATn FIFO input is sampled data at a rate set by DRAT in command [A6/A7h Write/Read Converter Configuration, on page 88](#) and the DAT and HK FIFOs and LEN field are updated at the programmed data rate. Using the slowest sample rate of 2 ms in narrow band mode allows 12ms of data to be stored and supports a 10ms nominal polling rate. Use of wideband mode (if available) reduces the maximum sample rate to 1ms, corresponding to a 5ms polling rate.

To get meaningful DC test data, the device should be configured as described in [A6/A7h Write/Read Converter Configuration, on page 88](#). This data will also be transmitted on the DXA pin unless the CTP bit is set. To read the hook data in IDLE mode, the codec must also be activated.

While this register can be read in GCI mode, the monitor channel protocol only allows this data to be sampled at a slow rate. It is recommended that the compressed B channel data is read directly from the GCI bus in this mode.

*Power Up and Hardware Reset ($\overline{\text{RST}}$) Value = 0000 0000 0000 0000 0000 0000 0000 h

D0/D1h Write/Read Metering Parameters

Command	D7*	D6	D5	D4	D3	D2	D1	D0
W: D0h R: D1h	1	1	0	1	0	0	0	R/W
I/O Data Byte 1	MTRF	MLIM6	MLIM5	MLIM4	MLIM3	MLIM2	MLIM1	MLIM0
I/O Data Byte 2	SOREV	MTRSL6	MTRSL5	MTRSL4	MTRSL3	MTRSL2	MTRSL1	MTRSL0
I/O Data Byte 3	MTRDR7	MTRDR6	MTRDR5	MTRDR4	MTRDR3	MTRDR2	MTRDR1	MTRDR0
I/O Data Byte 4	MTRPK7	MTRPK6	MTRPK5	MTRPK4	MTRPK3	MTRPK2	MTRPK1	MTRPK0

MTRF: Metering frequency

0*: 12 kHz
 1: 16 kHz

MLIM[6:0]: This field sets the peak voltage level of the metering signal voltage at the AC sense point. MLIM is programmed as an unsigned integer.
 If MTRF is 0 (12 kHz), MLIM has a step size of 15 mVrms
 If MTRF is 1 (16 kHz), MLIM has a step size of 18 mVrms
 (default = 0100001b)

Metering signals up to 0.5 Vrms at the line are supported.

SOREV: Smooth ramping or abrupt application

0*: Smooth ramping, should be used for all normal applications
 1: Abrupt ramping, should only be used for diagnostic testing

MTRSL[6:0]: Metering Slope. This parameter sets the metering output current limit into a short circuit between TIPD and RINGD. MTRSL is programmed as an unsigned integer.

MTRSL has a range of 0 – 8.636 mArms and a step size of 68 μ A, provided AR is set to +6 dB and DRL is enabled in the [50/51h Write/Read Voice Path](#)

[Gains, on page 77](#)

The metering ramp lasts for 20 ms or until the voltage specified by MLIM is reached. The slope in mA/ms can be calculated by $\text{slope} = \frac{\text{MTRSL}}{20\text{msec}}$. If

MTRSL is too small to generate the voltage MLIM, the ramp will stop at the output current MTRSL after 20 ms.
(default = 0111101b)

MTRDR[7:0]: Metering Duration. MTRDR sets the time metering output current is applied to the line. 0 – 637.5 ms with a step size of 2.5 ms. A value of 00h indicates continuous metering. (default = 3Ch = 150 ms)

MTRPK[7:0]: This field reads the maximum voltage level of the metering signal voltage at the AC sense point.
If MTRF is 0 (12 kHz), MTRPK has a step size of 15 mVrms
If MTRF is 1 (16 kHz), MTRPK has a step size of 18 mVrms
This field is read only. Writes to this location are ignored.

*Power Up and Hardware Reset ($\overline{\text{RST}}$) Value = 213D 3C00h

D2/D3h Write/Read Signal Generator A, B and Bias Parameters.

Command	D ₇	D ₆	D ₅	D ₄	D ₃	D ₂	D ₁	D ₀
W: D2h R: D3h	1	1	0	1	0	0	1	$\overline{\text{R/W}}$
I/O Byte 1	RSVD	RSVD	RSVD	RSVD	RSVD	RMPSLP	CNTRMP	SINTRAP
I/O Byte 2	BIAS15	BIAS14	BIAS13	BIAS12	BIAS11	BIAS10	BIAS9	BIAS8
I/O Byte 3	BIAS7	BIAS6	BIAS5	BIAS1	BIAS3	BIAS2	BIAS1	BIAS0
I/O Byte 4	RSVD	FRQA14	FRQA13	FRQA12	FRQA11	FRQA10	FRQA9	FRQA8
I/O Byte 5	FRQA7	FRQA6	FRQA5	FRQA4	FRQA3	FRQA2	FRQA1	FRQA0
I/O Byte 6	AMPA15	AMPA14	AMPA13	AMPA12	AMPA11	AMPA10	AMPA9	AMPA8
I/O Byte 7	AMPA7	AMPA6	AMPA5	AMPA4	AMPA3	AMPA2	AMPA1	AMPA0
I/O Byte 8	RSVD	FRQB14	FRQB13	FRQB12	FRQB11	FRQB10	FRQB9	FRQB8
I/O Byte 9	FRQB7	BRQA6	FRQB5	FRQB4	FRQB3	FRQB2	FRQB1	FRQB0
I/O Byte 10	AMPB15	AMPB14	AMPB13	AMPB12	AMPB11	AMPB10	AMPB9	AMPB8
I/O Byte 11	AMPB7	AMPB6	AMPB5	AMPB4	AMPB3	AMPB2	AMPB1	AMPB0

RSVD Reserved for future use. Always write as 0, but 0 is not guaranteed when read.

RMPSLP: Ramp Slope

- 0*: Leaves the sign of AMPA unchanged.
- 1: Negates AMPA to change the ramp direction.

This bit also has the effect of inverting the sign of a continuous wave driven from signal generator A.

CNTRMP: Continuous or Ramp operation

- 0*: Signal Generators A and B output continuous waves.
- 1: A single ramp is output starting from the DC offset set by the BIAS parameter and ramping by an amplitude specified by AMPA. The ramp is started when Generator A is enabled or a set of signal generator A parameters are written. The new ramp begins wherever the generator A output is sitting, and changes by a value set by AMPA and RMPSLP

In a signal consisting of a series of ramped signal changes, BIAS should normally be kept constant at the beginning value of the signal. Changing BIAS will cause an abrupt signal change.

SINTRAP must be set to 1 if CNTRMP is set to 1.

FRQA is programmed with the rise time of the linear ramp. This is given by:

$$FRQA = \frac{1.365}{T_{rise}}$$

where FRQA is a signed 16 bit integer. Negative values are invalid.

SINTRAP:

Sinusoidal or Trapezoidal output

0*:

Signal Generators A and B output sinusoidal waves.

1:

Signal Generator A outputs trapezoidal waves and signal generator B outputs nothing.

SINTRAP must be set to 1 if CNTRMP is set to 1.

BIAS:

Generate DC bias offset parameter.

Signed 16 bit integer with a range of ± 156 V in ringing and a scale of 4.76 mV/step.

(default = 0000h = 0V).

FRQA[14:0]:

Frequency or rise time parameter of signal generator A

When SINTRAP = 0, FRQA is an unsigned number with a frequency step size of 0.3662 Hz. The maximum allowable frequency is 3400 Hz in normal mode and 6800Hz in wideband mode. The signal generator runs through the voice path which has internal filters and a sampling rate of 8KSa/sec (16KSa/sec. in wideband mode).

When SINTRAP = 1, the waveshape is set to trapezoidal, the FRQA parameter sets the rise time according to the following formula:

$$FRQA = \frac{2.73}{T_{rise}}$$

where FRQA is a signed 16 bit integer. Negative values are invalid.

(default = 0037h = 20.1Hz)

AMPA[15:0]:

Amplitude parameter of signal generator A

Signed 16 bit integer with a range of ± 156 V in ringing and a scale of 4.76 mV/step

Up to +3.14 dBm0 in active states into the voice path

AMPA is the peak value of the digital sine wave or trapezoid wave.

A positive value will start the wave at 0 with a positive initial first derivative (wave goes up). A negative value will start the wave at 0 with a negative initial first derivative (wave goes down). In ringing, the signal generator is not connected to the line until a zero voltage cross with VOC if ZXR is set to 0.

(default = 4AA4h = 91 V)

FRQB[14:0]:

Frequency parameter of signal generator B

When SINTRAP = 0, FRQB is an unsigned number with a frequency step size of 0.3662 Hz. The maximum allowable frequency is 3400 Hz in normal mode and 6800Hz in wideband mode. The signal generator runs through the voice path which has internal filters and a sampling rate of 8KSa/sec (16KSa/sec. in wideband mode).

When SINTRAP = 1, the waveshape is set to trapezoidal, the FRQB parameter sets the frequency according to the following formula:

$$FRQB = \frac{8000}{F_{Ring}}$$

where FRQB is a signed 16 bit integer. Negative values are invalid.

(default = 0000h)

AMPB[15:0]: Amplitude parameter of signal generator B
 Up to +3.14 dBm0 in active states into the voice path
 AMPB is the peak value of the digital sine wave.
 A positive value will start the wave at 0 with a positive initial first derivative (wave goes up). A negative value will start the wave at 0 with a negative initial first derivative (wave goes down).
 (default = 0000h)

Note: Ringing automatically uses signal generator A's parameters. The POLNR bit will affect the sign of the sum of the tone generators and bias. If the generator is used to control the metallic voltage either for ringing or for diagnostic tests, positive generator values produce reverse polarity voltages (ring more positive than tip) when POLNR is 0.

*Power Up and Hardware Reset (\overline{RST}) Value = 00 0000 0037 4AA4 0000 0000h

D4/D5h Write/Read Signal Generator C and D Parameters.

Command	D ₇	D ₆	D ₅	D ₄	D ₃	D ₂	D ₁	D ₀
W: D4h R: D5h	1	1	0	1	0	1	0	R/ \overline{W}
I/O Byte 1	RSVD	FRQC14	FRQC13	FRQC12	FRQC11	FRQC10	FRQC9	FRQC8
I/O Byte 2	FRQC7	FRQC6	FRQC5	FRQC4	FRQC3	FRQC2	FRQC1	FRQC0
I/O Byte 3	AMPC15	AMPC14	AMPC13	AMPC12	AMPC11	AMPC10	AMPC9	AMPC8
I/O Byte 4	AMPC7	AMPC6	AMPC5	AMPC4	AMPC3	AMPC2	AMPC1	AMPC0
I/O Byte 5	RSVD	FRQD14	FRQD13	FRQD12	FRQD11	FRQD10	FRQD9	FRQD8
I/O Byte 6	FRQD7	BRQA6	FRQD5	FRQD4	FRQD3	FRQD2	FRQD1	FRQD0
I/O Byte 7	AMPD15	AMPD14	AMPD13	AMPD12	AMPD11	AMPD10	AMPD9	AMPD8
I/O Byte 8	AMPD7	AMPD6	AMPD5	AMPD4	AMPD3	AMPD2	AMPD1	AMPD0

FRQC[14:0]: Frequency parameter of signal generator C
 FRQC is an unsigned number with a frequency step size of 0.3662 Hz.
 The maximum allowable frequency is 3400 Hz in normal mode and 6800Hz in wideband mode. The signal generator runs through the voice path which has internal filters and a sampling rate of 8Ksa/sec (16Ksa/sec in wideband mode).
 (default = 1777h = 2200Hz)

AMPC[15:0]: Amplitude parameter of signal generator C
 Up to +3.14 dBm0 into the voice path
 AMPC is the peak value of the digital sine wave. A positive value will start the wave at 0 with a positive initial first derivative (wave goes up). A negative value will start the wave at 0 with a negative initial first derivative (wave goes down).
 (default = 27D4h = -7 dBm0)

FRQD[14:0]: Frequency parameter of signal generator D
 FRQD is an unsigned number with a frequency step size of 0.3662 Hz.
 The maximum allowable frequency is 3400 Hz in normal mode and 6800Hz in wideband mode. The signal generator runs through the voice path which has internal filters at a sampling rate of 8Ksa/sec (16Ksa/sec in wideband mode).
 (default = 0CCDh = 1200Hz)

AMPD[15:0]: Amplitude parameter of signal generator D
 Up to +3.14 dBm0 into the voice path
 AMPD is the peak value of the digital sine wave. A positive value will start the wave at 0 with a positive initial first derivative (wave goes up). A negative value

will start the wave at 0 with a negative initial first derivative (wave goes down).
(default = 27D4h = -7 dBm0)

Caller ID automatically uses the parameters stored in signal generators C and D.

*Power Up and Hardware Reset ($\overline{\text{RST}}$) Value = 1777 27D4 0CCD 27D4

DE/DFh Write/Read Signal Generator Control

Command	D ₇	D ₆	D ₅	D ₄	D ₃	D ₂	D ₁	D ₀
W: DEh R: DFh	1	1	0	1	1	1	1	R/ $\overline{\text{W}}$
I/O Data	SGCAD	CNTOS	RSVD	EGBIAS	EGD	EGC	EGB	EGA

RSVD Reserved for future use. Always write as 0, but 0 is not guaranteed when read.

SGCAD: Signal Generator Cadencing

0*: No Signal generator cadencing

1: The enabled tone generators specified by EGA - EGBIAS will cadence on and off as determined by command [E0/E1h Write/Read Cadence Timer, on page 98](#)

The EGx bits will read back zero in the cadence off time.

This command makes use of the cadence timer. The enabled functions are toggled at a rate specified by the cadence timer. The CAD bit in command [4D/4Fh Read Signaling Register, on page 75](#) is set at the end of the on period, which can optionally generate an interrupt if MCAD is reset in command [6C/6Dh Write/Read Interrupt Mask Register, on page 82](#). At this time, the user may write new values into the cadence timer and reissue the signal generator control command.

If no enable bits are set, the cadencer will run and will still set the CAD bit at the end of the on period and can produce an interrupt. In this way, the cadencer can be used as a system timer.

CNTOS: Continuous or One Shot cadence operation.

0*: Continuous cadencing. Cadencing will continue until the user intervenes.

1: One shot. The generators will turn on for one on period only. All enable bits and SGCAD will be set to zero after the off period. An interrupt will be sent at the end of the on period.

EGBIAS: Enable DC Bias

0*: DC Bias disabled

1: DC Bias enabled

EGD: Enable Signal Generator D

0*: Generator D disabled

1: Generator D enabled

EGC: Enable Signal Generator C

0*: Generator C disabled

1: Generator C enabled

EGB: Enable Signal Generator B

0*: Generator B disabled

1: Generator B enabled

EGA: Enable Signal Generator A

0*: Generator A disabled

1: Generator A enabled

*Power Up and Hardware Reset ($\overline{\text{RST}}$) Value = 00h

E0/E1h Write/Read Cadence Timer

Command	D ₇	D ₆	D ₅	D ₄	D ₃	D ₂	D ₁	D ₀
W: E0h R: E1h	1	1	1	0	0	0	0	R/W
I/O Byte 1	RSVD	RSVD	RSVD	RSVD	RSVD	CADON ₁₀	CADON ₉	CADON ₈
I/O Byte 2	CADON ₇	CADON ₆	CADON ₅	CADON ₄	CADON ₃	CADON ₂	CADON ₁	CADON ₀
I/O Byte 3	RSVD	RSVD	RSVD	RSVD	RSVD	CADOFF ₁₀	CADOFF ₉	CADOFF ₈
I/O Byte 4	CADOFF ₇	CADOFF ₆	CADOFF ₅	CADOFF ₄	CADOFF ₃	CADOFF ₂	CADOFF ₁	CADOFF ₀

RSVD Reserved for future use. Always write as 0, but 0 is not guaranteed when read.

CADON[10:0]: Cadence On Time. 0 - 10.24 seconds with a scale of 5 ms per step. (default* = 190h = 2 sec)

CADOFF[10:0]: Cadence Off Time. 0 - 10.24 seconds with a scale of 5 ms per step. (default* = 320h = 4 sec)

During the ring off time, the system state is Active.

If the cadence off time is 0, the function will be enabled indefinitely.

The cadencer is a shared timer that is used for a variety of functions including: ringing cadencing, and tone pulsing e.g. howler tone generation. The on and off times are set by this command and the individual commands for these functions enable the cadencer.

*Power Up and Hardware Reset (\overline{RST}) Value = 0190 0320h

E2/E3h Write/Read Caller Identification Number Data

Command	D ₇	D ₆	D ₅	D ₄	D ₃	D ₂	D ₁	D ₀
W: E2h R: E3h	1	1	1	0	0	0	1	R/W
I/O Data	CID ₇	CID ₆	CID ₅	CID ₄	CID ₃	CID ₂	CID ₁	CID ₀

CID: Caller ID Data
 Writing to this register will send CID data to the subscriber line based on the status of the CIDDIS bit in command [EA/EBh Write/Read Caller Identification Number Parameters, on page 102](#). The CID bit in command [4D/4Fh Read Signaling Register, on page 75](#) is set when the Le88266/286 device becomes ready to receive more data, which can optionally generate an interrupt if MCID is reset in command [6C/6Dh Write/Read Interrupt Mask Register, on page 82](#).

The amplitude and frequency parameters for caller number delivery are programmed in [D4/D5h Write/Read Signal Generator C and D Parameters, on page 96](#). Except for the first byte, data may not be written to this register until the CID interrupt is received or CID state is Ready in [EA/EBh Write/Read Caller Identification Number Parameters, on page 102](#). If data is written before this interrupt is generated by the Le88266/286, the operation of the CID sequence is undefined.

*Power Up and Hardware Reset (\overline{RST}) Value = 00h

E4/E5h Write/Read Switching Regulator Parameters

Command	D7*	D6	D5	D4	D3	D2	D1	D0
W: E4h R:E5 h	1	1	1	0	0	1	0	R/W
I/O Data Byte 1	BSI1	BSI0	FLYBB	RSVD	RSVD	RSVD	RSVD	RSVD
I/O Data Byte 2	RSVD	SWFS1	SWFS0	SWYV ₄	SWYV ₃	SWYV ₂	SWYV ₁	SWYV ₀
I/O Data Byte 3	RSVD	RSVD	RSVD	SWZV ₄	SWZV ₃	SWZV ₂	SWZV ₁	SWZV ₀

RSVD	Reserved for future use. Always write as 0, but 0 is not guaranteed when read		
FLYBB:	Converter mode - Flyback or Inverting Buck-Boost		
0*:	Converters are in Flyback mode		
1:	Converters are in Inverting Buck-Boost mode.		
BSI[1:0]:	Battery Sense Select Input		
	The selection of which battery is sensed by which pin is determined by these bits as defined by the following table.		
	VBL sense pin	VBM sense pin	VBH sense pin
00*:	SWVSY	XB	SWVSZ
01:	SWVSY	SWVSZ	XB
10:	XB	SWVSY	SWVSZ
11:	RSVD	RSVD	RSVD
SWFS[1:0]:	Switching regulator frequency select. Selects the switching regulator clock in the three power modes. Non-default values are normally used in buck-boost applications. Applies to both switching regulators.		
	Low Power	Medium Power	High Power
00*:	48 kHz	96 kHz	384 kHz
01:	24 kHz	48 kHz	192 kHz
10:	12 kHz	24 kHz	96 kHz
11:	Reserved		
SWYV[4:0]:	Switching regulator Y voltage Specifies the fixed output voltage for switching regulator Y Range -5 V to -160 V with a step size of -5 V (default = 0Ah = -55 V)		
SWZV[4:0]:	Switching regulator Z voltage Specifies the fixed output voltage for switching regulator Z. Range -5 V to -160 V with a step size of -5 V (default = 0Ah = -55 V)		

The available SWxV voltage is internally clamped to -150 V.

This command does not depend on the state of the Channel Enable Register.

*Power Up and Hardware Reset (\overline{RST}) Value = 00 040Ah

E6/E7h Write/Read Switching Regulator Control

Command	D7*	D6	D5	D4	D3	D2	D1	D0
W: E6h R: E7h	1	1	1	0	0	1	1	R/W
I/O Data	RSVD	RSVD	RSVD	SWOVP	ZM ₁	ZM ₀	YM ₁	YM ₀

RSVD Reserved for future use. Always write as 0, but 0 is not guaranteed when read.

SWOVP: Switcher Over Voltage Protection enable

0: No over voltage sense protection.

1: Over voltage protection enabled.
Nominal threshold is below -110 V. If this threshold is exceeded at any of the voltage sense pins, the corresponding switching regulators will be shut down and OCALMY or OCALMZ bits will be set. An over-voltage sensed at XB can shut down both switching regulators, although the thresholds are independent. If SWOVP is set, at least one channel should be in the Disconnect state before the switching regulators are enabled

YM[1:0]: Switcher Y mode bits

ZM[1:0]: Switcher Z mode bits

The mode bits are defined in the following table:

Mode Bit 1	Mode Bit 0	Mode Definition	Designation
0*	0*	Switching Regulators Disabled	OFF
0	1	Low Power Lowest Switcher Clock	LP
1	0	Medium Power Medium Switcher Clock	MP
1	1	High Power High Switcher Clock	HP

From the power up shutdown state, if the on chip switching regulator controllers are being used to generate the system batteries, the power supplies should be started in mode 1 or 2. After at least ten milliseconds in these modes, mode 3 can be selected if high power output is required. The System State can then be programmed as desired. The device can only return to the shutdown state if both switching regulators are disabled.

For correct battery switching threshold setting, both switching regulator controllers must be enabled, even if they are not being used to generate battery voltages. Ensure the ZM and YM bits are non zero after the device is initialized.

This command does not depend on the state of the Channel Enable Register.

*Power Up and Hardware Reset (\overline{RST}) Value = 00h

E8/E9h Write/Read Battery Calibration Register

Command	D7	D6	D5	D4	D3	D2	D1	D0
W: FAh R: FBh	1	1	1	1	1	0	1	$\overline{R/W}$
I/O Data Byte 1	RSVD	RSVD	d_swcal2	d_swcal1	d_swcal0	RSVD	RSVD	c_abs_deb
I/O Data Byte 2	RSVD	RSVD	RSVD	RSVD1	RSVD	RSVD	RSVD	RSVD

RSVD	Reserved for future use. Always write as 0, but 0 is not guaranteed when read.
RSVD1	Reserved for future use. Always write as 1.
d_swcal[2:0]:	Switching regulator voltage calibration.
000	0.00 V
001	1.25 V
010	2.50 V
011	3.75 V
100	0.00 V
101	-1.25 V
110	-2.50 V
111	-3.75 V
CH1 -	switcher Y calibration.
CH2 -	switcher Z calibration.
c_abs_deb:	Auto bat switching debounce algorithm.
0:	Use original ABS algorithm. If line voltage exceeds switch threshold, switch after 2 ms unless line voltage returns past (Threshold + hysteresis) within the 2 ms wait period
1:	Use new ABS algorithm. Line voltage must exceed current switch threshold for 2 ms (Sampled at 8 kHz) before switching. This algorithm is less sensitive to short glitches and AC signals near the threshold. It may require the nominal threshold to be reduced by using a larger VAS to avoid AC signal clipping at the threshold.

*Power Up and Hardware Reset (\overline{RST}) Value = 0010h

EA/EBh Write/Read Caller Identification Number Parameters

Command	D7	D6	D5	D4	D3	D2	D1	D0
W: EAh R: EBh	1	1	1	0	1	0	1	R/W
I/O Data	CIDST2	CIDST1	CIDST0	EOM	FBDIS	FBSRT	FBSTP	CIDDIS

CIDST[2:0]: These bits report back the state of the CID state machine.

CIDST2	CIDST1	CIDST0	State
0	0	0	Idle*
0	0	1	Empty
0	1	0	Half Full
0	1	1	Last byte
1	0	0	Last 2 bytes
1	0	1	Underrun
1	1	0	Full
1	1	1	Last 3 bytes

These bits are read only. Writes to these bits are ignored.

EOM: End of Message

- 0*: The end of message is not the next byte written
- 1: The next byte written will be the last byte in the CID message

This bit is reset after the last byte is transmitted

FBDIS: Frame Bit Disable

- 0*: The CID message data written to Le88266/286 is automatically framed by the Le88266/286 device with the start and stop bit specified in FBSRT and FBSTP
- 1: No start/stop bit framing is done by the Le88266/286 device. The data written to Le88266/286 is passed directly to the subscriber line. The user may frame their data by embedding start/stop bits within the data.

FBSRT: Frame Bit Start bit

- 0*: Start bit will be a 0 (space) if FBDIS = 0
- 1: Start bit will be a 1 (mark) if FBDIS = 0

This bit is ignored if FBDIS = 1.

FRSTP: Frame Bit Stop bit

- 0: Stop bit will be a 0 (space) if FBDIS = 0
- 1*: Stop bit will be a 1 (mark) if FBDIS = 0

This bit is ignored if FBDIS = 1

CIDDIS: Caller ID disable

- 0: Caller ID is enabled. Writes to the CID data register will be driven onto the subscriber line.
- 1*: Caller ID is disabled. Any writes to the CID data register will not be driven to the subscriber line.

*Power Up and Hardware Reset (\overline{RST}) Value = 03h

EC/EDh Write/Read Internal Configuration Register 1
EE/EFh Write/Read Internal Configuration Register 2
F2/F3h Write/Read Internal Configuration Register 3
F4/F5h Write/Read Internal Configuration Register 4

Command	D7	D6	D5	D4	D3	D2	D1	D0
ICRx Command	x	x	x	x	x	x	x	R/W
I/O Data Byte 1	MC15	MC14	MC13	MC12	MC11	MC10	MC9	MC8
I/O Data Byte 2	C15	C14	C13	C12	C11	C10	C9	C8
I/O Data Byte 3	MC7	MC6	MC5	MC4	MC3	MC2	MC1	MC0
I/O Data Byte 4	C7	C6	C5	C4	C3	C2	C1	C0

The command byte contains the address of the register to be accessed.

The first and third bytes are masks for the second and fourth control bytes. When the mask bit is 0, the corresponding state machine control bit can not be written (read only). When the mask bit is 1, the value written to the corresponding state machine control bit overrides the default behavior. Reads from these registers reflect the last written mask bits and the actual internal register values. These values are the same as the values written to the internal configuration register when the mask bits are 1 and are the state machine values otherwise. The mask control bits (MC*) are reset by a hardware reset or a software reset on a per channel basis.

These registers must be accessed as described in various sections of the device block descriptions for correct operation.

FA/FBh Write/Read Internal Configuration Register 5

Command	D7	D6	D5	D4	D3	D2	D1	D0
W: FAh R: FBh	1	1	1	1	1	0	1	R/W
I/O Data Byte 1	feed_hold3	feed_hold2	feed_hold1	feed_hold0	bat_hold3	bat_hold2	bat_hold1	bat_hold0
I/O Data Byte 2	h2ms3	h2ms2	h2ms1	h2ms0	subst3	subst2	subst1	subst0

This register allows certain internal timing values to be adjusted, which can optimize transient response.

feed_hold[3:0]: DC Feed speedup hold time. (0 - 15 ms with a scale of 1 ms/step)
Default 4 ms

bat_hold[3:0]: Power supply speedup hold time. (0 - 15 ms with a scale of 1 ms/step)
Default 10 ms

h2ms[3:0]: Hook 2 ms debounce time. (0 - 3.75 ms with a scale of 0.25 ms/step)
Default 2.75 ms

subst[3:0]: The system sub-state field is read only

This register is reset to the default value by a hardware reset or a software reset on a per channel basis.

*Power Up and Hardware Reset (RST) Value = 4AB0h

FC/FDh Write/Read DC Calibration Register

Command	D7	D6	D5	D4	D3	D2	D1	D0
W: FCh R: FDh	1	1	1	1	1	0	1	R/W
I/O Data Byte 1	ABSCAL3	ABSCAL2	ABSCAL1	ABSCAL0	md_bat_lm	mc_inp_offs	RSVD	RSVD
I/O Data Byte 2	SWVSx_sns	RDC_sns	TDC_sns	c_ibuff5_vo c_off	d_bat_lm	c_inp_offs	bshv1	bshv0

ABSCAL[3:0]: Auto Battery Switch Threshold calibration voltage
Correction voltage to be applied to the battery switch threshold to be at the threshold when the calibration currents are applied.

0000*	0.00 V
0001	0.75 V
0010	1.50 V
0011	2.25 V
0100	3.00 V
0101	3.75 V
0110	4.50 V
0111	5.25 V
1000	0.00 V
1001	-0.75 V
1010	-1.50 V
1011	-2.25 V
1100	-3.00 V
1101	-3.75 V
1110	-4.50 V
1111	-5.25 V

md_bat_lm: Low or Mid battery override.

0*	Disable Override.
1	Enable override of the status of the Battery Switch Detector signal fed to the System State machine using the d_bat_lm bit.

mc_inp_offs: Input Offset Override.

0*	Disable Override.
1	Enable override of the input offset current applied to the TDC and RDC pins which corrects for the offset voltage created by operating at VREF instead of ground using the c_inp_offs bit.

SWVSx_sns: Channel 1: SWVSY sense disable
Channel 2: XB sense disable
(Assumes BSI bits are 00 in Switching Regulator Parameter register)

0*	Enable voltage sensing via the associated pin.
1	Disable voltage sensing from the associated pin and apply internal -16 V reference to corresponding battery sense circuits. If RDC_sns is set, apply internal -20 V reference when POLNR = 0 and -4 V when POLNR = 1 to the RDC sense path. If TDC_sns is set, apply internal -4 V reference when POLNR = 0 and -20 V when POLNR = 1 to the TDC sense path. When this bit is set, the bshv field is also forced to 00b (1 V hysteresis) Note that the Switching Regulator Control register MUST be 00h (Regulators disabled) before setting this bit.

RDC_sns: RDC pin sense disable

0*	Enable voltage sensing via the RDC pin.
1	Disable voltage sensing from the RDC pin. This effectively opens the RDC sense input and allows a DC input offset voltage calibration factor to be measured using the appropriate converter configuration setting.
TDC_sns:	TDC pin sense disable
0*	Enable voltage sensing via the associated pin.
1	Disable voltage sensing from the TDC pin This effectively opens the TDC sense input and allows a DC input offset voltage calibration factor to be measured using the appropriate converter configuration setting.
	Disabling all three sense inputs on each channel allows the Automatic Battery Switch Threshold voltage to be calibrated. Place the device into the Active Mid or Low Battery state with automatic battery switching enabled. The firmware should then increment through each ABSCAL value in turn starting at -5.25 V, checking the d_bat_lm bit after at least 2 ms for each step. The ABSCAL value written before the bit is set is the optimum calibration value for that channel and polarity. Repeat in the other polarity to determine the ABSCAL values to be applied in Normal and Reverse polarity, store them on a per channel basis and apply them to the ABSCAL bits in the corresponding states.
c_ibuff5_voc_off:	Turns off Internal current buffer ibuff5 Can be used for debug and/or ILA calibration
0*:	Ibuff5 on.
1:	Ibuff5 off
d_bat_lm:	Battery Switch Detector Low or Mid battery select bit (This bit is undefined in the Shutdown state and can read back either 1 or 0) When read, this bit indicates the status of the Battery Switch detector. When written and m_d_bat_lm = 1, this sets the value of the detector passed to the system state machine.
0*	Low Battery selected.
1	Mid Battery selected.
c_inp_offs:	TDC and RDC pin input offset control.
0*	Input offset enabled.
1	Input offset disabled.
bshv[1:0]:	Battery Switch Hysteresis Voltage.
00	1.0 V
01	3.0 V
10*	5.0 V
11	7.0 V

When automatic battery switching is used, a point referenced to low battery is used to make the battery selection. The programmable VAS parameter is added to the loop current times 200 ohms to set the Low to Mid battery transition point. The Mid to Low battery transition point is set bshv volts closer to ground than this point.

*Power Up and Hardware Reset ($\overline{\text{RST}}$) Value = 0002h

11.0 Physical Dimensions

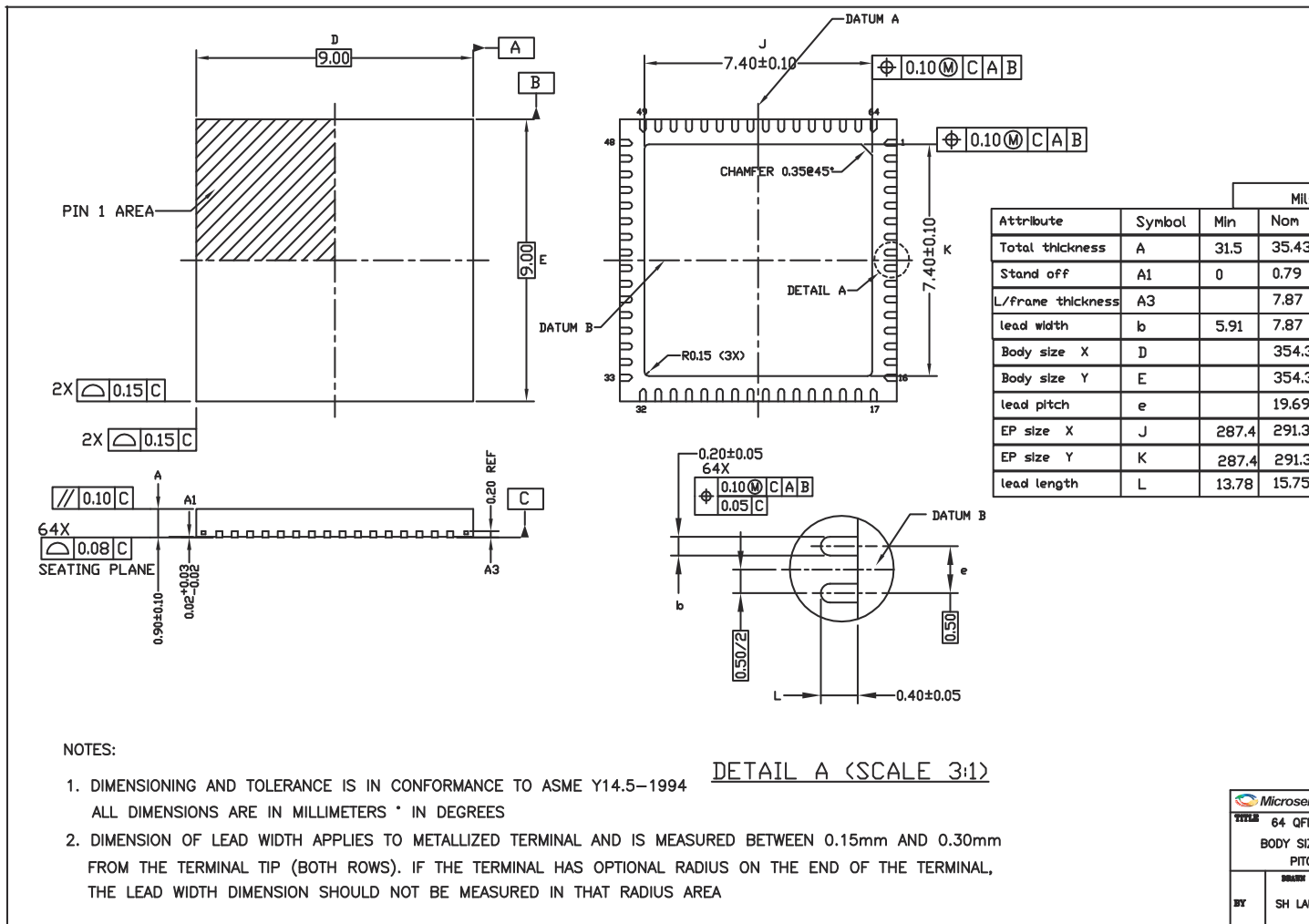
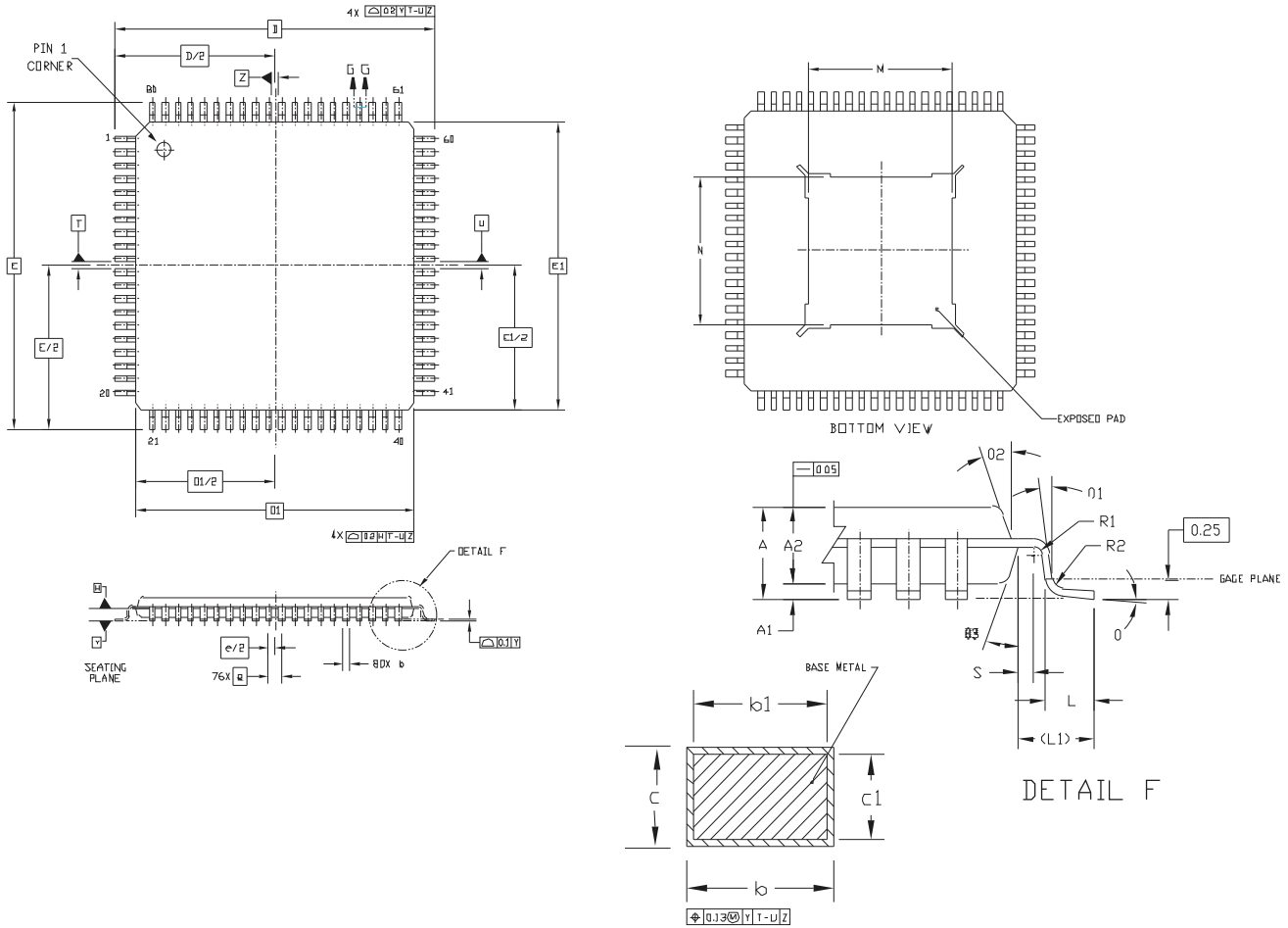

Figure 45 - 64-Pin QFN

14 x 14 x 1.4 LQFP 80 LD Exposed Pad



DIM	MIN	NOM	MAX	DIM	MIN	NOM	MAX	DIM	MIN	NOM	MAX
A	---		1.6	L1	1 REF						
A1	0.05		0.15	R1	0.08		---				
A2	1.35	1.4	1.45	R2	0.08		0.2				
b	0.22	0.32	0.38	S	0.2		---				
b1	0.22	0.3	0.33	θ	0°	3.5°	7°				
c	0.12		0.2	θ1	0°		---				
c1	0.12		0.16	θ2	11°	12°	13°				
D	16 BSC			θ3	11°	12°	13°				
D1	14 BSC			N	7.3		7.5				
e	0.65 BSC			N	7.3		7.5				
E	16 BSC										
E1	14 BSC										
L	0.45	0.6	0.75								
				UNIT		DIMENSION AND TOLERANCES		REFERENCE DOCUMENT			
				MM							

NOTES:

- DIMENSIONS D1 AND E1 DO NOT INCLUDE MOLD PROTRUSION. ALLOWABLE PROTRUSION IS 0.25 PER SIDE. DIMENSIONS D1 AND E1 DO INCLUDE MOLD MISMATCH AND ARE DETERMINED AT DATUM PLANE DATUM H.
- DIMENSION b DOES NOT INCLUDE DAMBAR PROTRUSION. ALLOWABLE DAMBAR PROTRUSION SHALL NOT CAUSE THE LEAD WIDTH TO EXCEED THE MAXIMUM b DIMENSION BY MORE THAN 0.08 mm. DAMBAR CANNOT BE LOCATED ON THE LOWER RADIUS OR THE FOOT. MINIMUM SPACE BETWEEN PROTRUSION AND AN ADJACENT LEAD IS 0.07mm.

Figure 46 - 80-Pin eLQFP

11.1 Detailed Bottom View of 80-Pin eLQFP

Dimensions in mm.

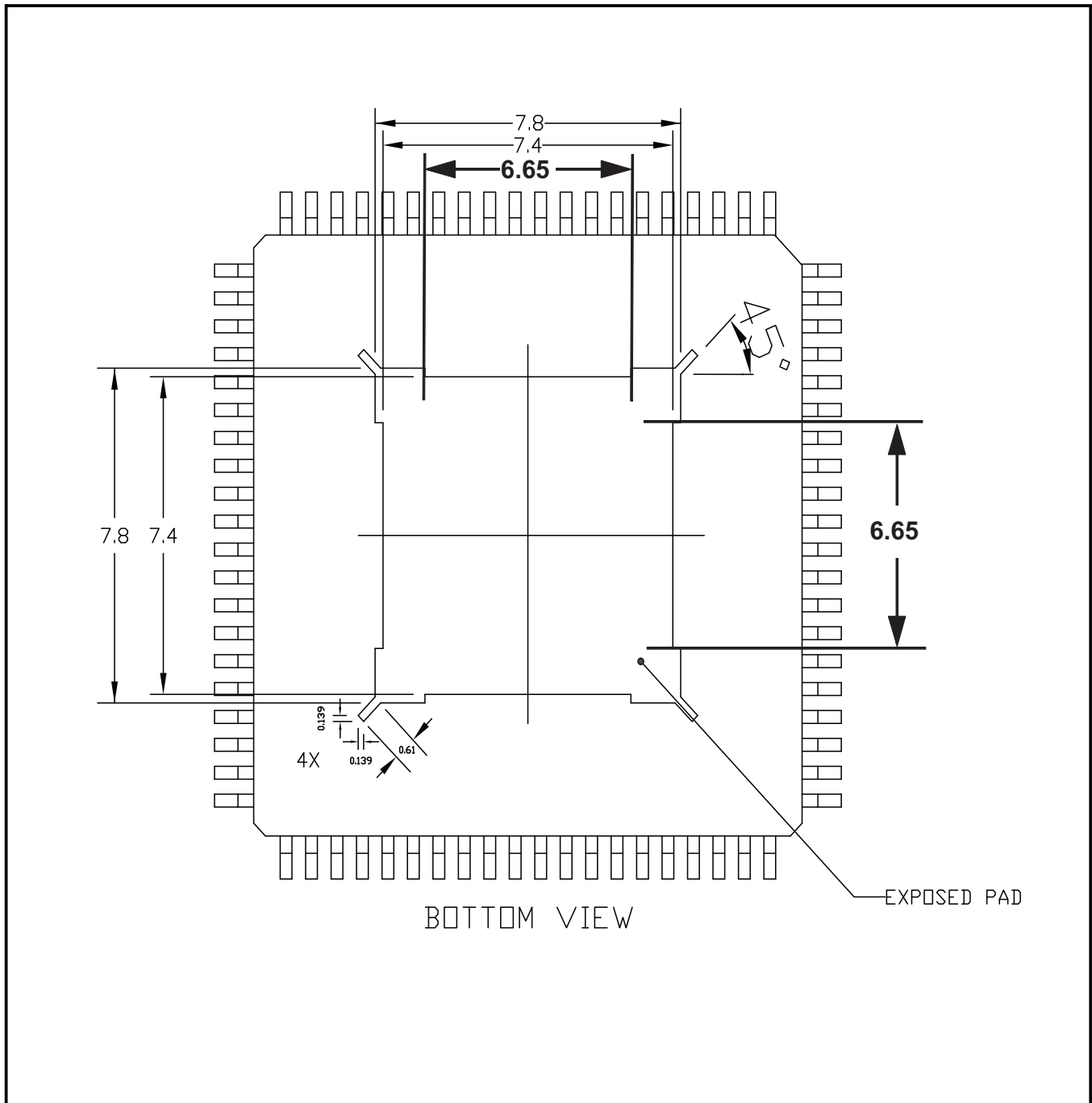

12.0 Recommended Land Patterns

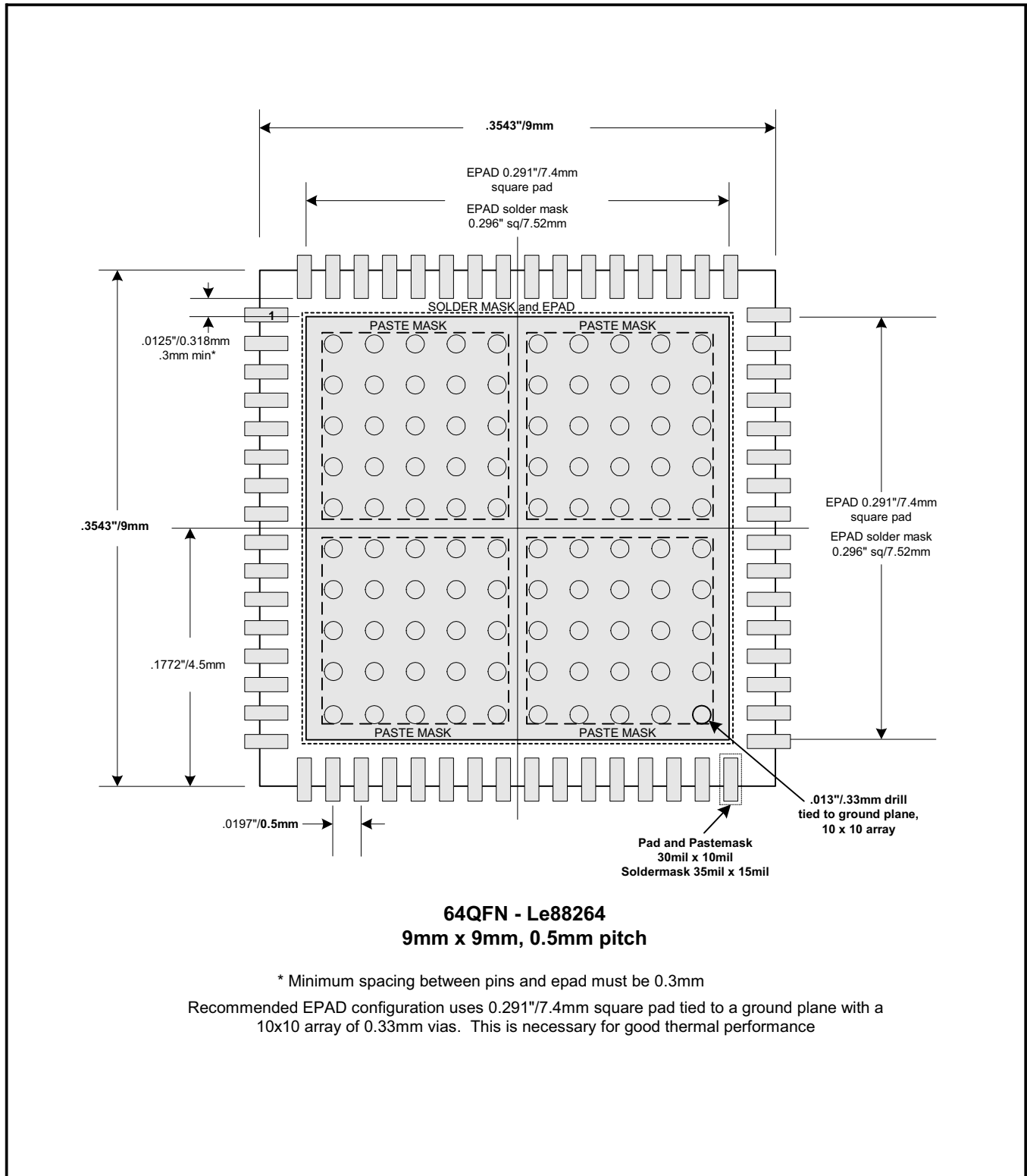

Figure 47 - 64-Pin QFN

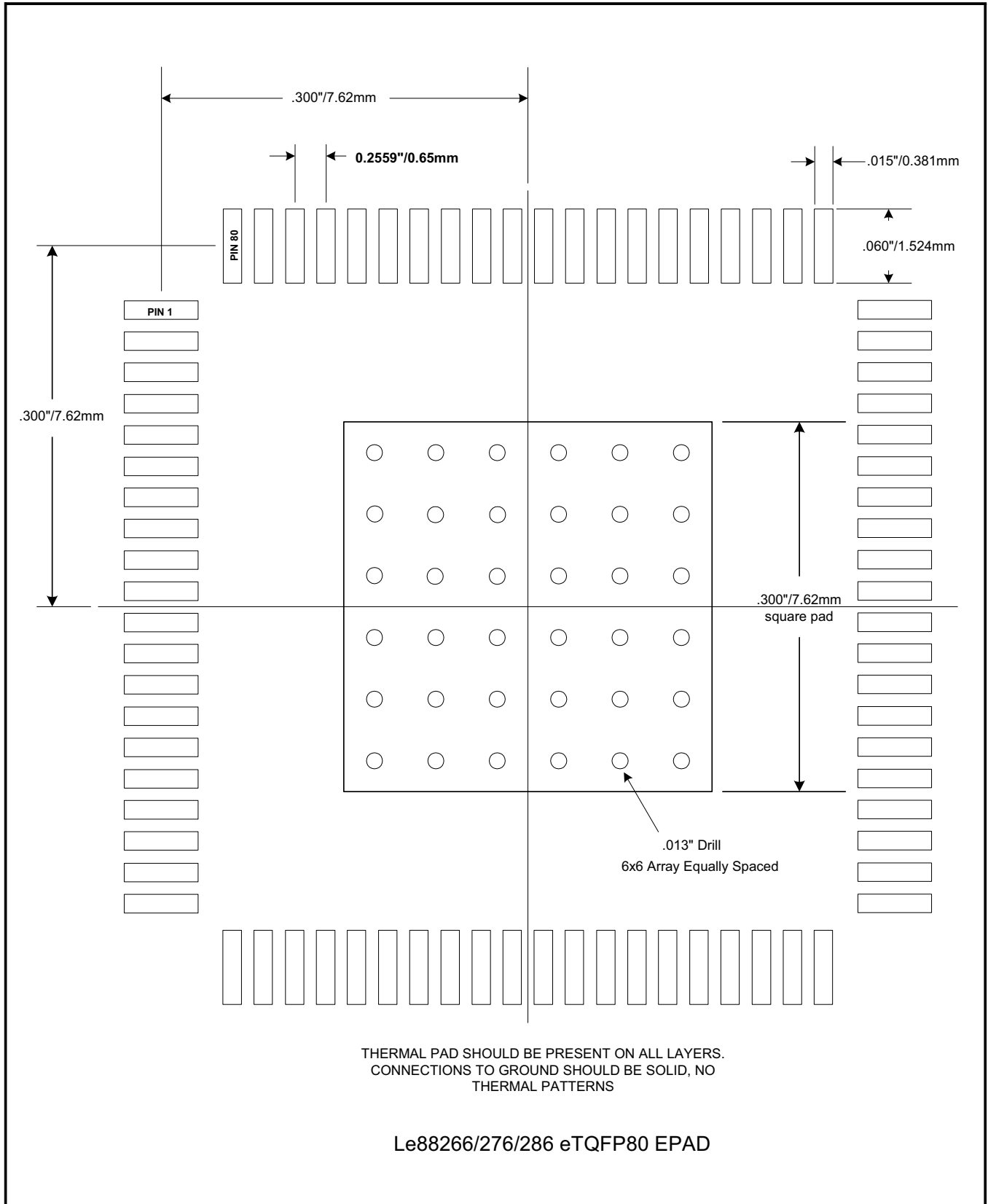

Figure 48 - 80-Pin eLQFP

13.0 Related Collateral

13.1 Documentation

- **Le71HR8864G and Le71HR8865G Reference Design User's Guide for the Le88266 Voiceport Device**
 - Document #: 139962
- **Le880SLVV & Le890SLVV VeriVoice™ Auditor Test Suite Software for VE880 and VE890 Series Data Sheet**
 - Document #: 081489
- **Le880SLVVP VeriVoice™ Professional Test Suite Software for VE880 Series Data Sheet**
 - Document #: 081516
- **VE8820 Dual Channel Tracking Battery Wideband VoicePort™ Chipset Data Sheet**
 - Document #: 081574

13.2 Development Hardware

- **Two Channel ABS eLQFP VoicePort Line Module** - OPN: Le71HR8865G
- **Two Channel ABS QFN VoicePort Line Module** - OPN: Le71HR8864G
 - The Le71HR8864G and Le71HR8865G are two channel FXS line modules designed to interface with the Microsemi Telephony Access Platform™ (ZTAP) for Microsemi Auto Battery Switching (ABS) VoicePort™ Le88266TQC/Le88266DLC silicon evaluation. This user's manual provides sample operating instructions, schematic, bill of materials, and layout references.

13.3 Development Software

- **VoicePath™ API-II** - OPN: Le71SK0002
 - The VP-API-II is a set of 'C' source used by the host application to interface to the VE880 Series and other Microsemi voice product families. A signed Software License Agreement is required.
- **VoicePath™ API-II Lite** - OPN: Le71SDKAPIL
 - The VP-API-II Lite is identical to VP-API-II, with reduced functionality. VP-API-II Lite does not support cadencing, caller ID, or call progress tone generation. A Software License Agreement is not required for VP-API-II Lite.
- **VoicePath™ Profile Wizard** - OPN: Le71SDKPRO
 - The VP Profile Wizard is a windows based software program that aids in the organization and creation of configuration profiles used in the VP-API-II into a single project file.
- **VeriVoice™ Auditor Test Suite** - OPN: Le880SLVV
 - The VeriVoice™ Auditor Test Suite for the VE880 Series is a subscriber line (FXS) test software package for VoIP equipment. It features all the outward tests of the *Telcordia GR-909-CORE* standard and returns pass / fail results. VeriVoice™ Auditor is one of the industry's most cost effective VoIP line testing solution.
- **VeriVoice™ Professional Test Suite** - OPN: Le880SLVVP
 - The VeriVoice™ Professional Test Suite for the VE880 Series is a super set of the VeriVoice™ Auditor software package providing measured results and greater flexibility. It also features several inward self tests to verify the operation of the FXS subsystem. VeriVoice™ Professional is one of the industry's most complete solution for VoIP line testing and helps reduce the cost of ownership for service providers.

14.0 Revision History

Version 1 to 2

- Eliminated I/O1 open drain mode and direct support for 5-V relays
Changed [Features, on page 1](#)
Changed description of [Input / Output Block, on page 20](#)
Eliminated 5-V tolerance specifications for I/O1 in [Absolute Maximum Ratings, on page 40](#) and [Operating Ranges, on page 41](#). I/O1 voltage range is now specified under digital pins
Updated [52/53h Write/Read Input/Output Data Register, on page 77](#) and [54/55h Write/Read Input/Output Direction Register, on page 78](#) descriptions to eliminate support of Open Drain I/O1 mode.
Added requirement for external catch diode across the relay
- Added detail to metering current capability under [Metering, on page 28](#)
- Added detail on power supply initialization under [Line Testing, on page 32](#)
- Updated [Supply Currents and Power Dissipation, on page 42](#)
- Corrected test conditions, units and notes for [Test Load Switch \(Le88286DLC Device Only\), on page 44](#)
- Relaxed ringing DC offset specification under [Ringing, on page 45](#)
- Specified battery voltage accuracy in [Switching Regulator Controller, on page 45](#)
- Relaxed battery measurement offset voltage errors in [Converter Configuration Signal Sense Accuracy, on page 46](#)
- Corrected Oh-hook gain accuracy and wideband ICN in [Transmission Characteristics - Narrowband Codec Mode, on page 47](#) and [Transmission Characteristics - Wideband Codec Mode, on page 54](#)
- Maximum PCLK period corrected to align with 1.024MHz PCLK capability in [PCM Interface Timing, on page 59](#)
- Corrected SWOUTx typical rise and fall times in [Switcher Output Timing, on page 65](#)
- Updated [Le88266/286 VoicePort™ Device Parts List, on page 68](#) to reflect preferred logic level FET in switching regulator
- Updated description of OCALMx bits in [4D/4Fh Read Signaling Register, on page 75](#)

Version 2 to Released, March 2011

- Updated format to align with current Microsemi data sheet standard, front page re-formatted
- Added information on new 64-pin QFN package option on front page, also [See Connection Diagrams and Pin Descriptions, on page 34](#), [73h Read Revision and Product Code Number \(RCN,PCN\), on page 83](#) and [Physical Dimensions, on page 106](#)
- Updated [Metering, on page 28](#)
- Added section on line testing, [See Line Testing, on page 32](#).
- Updated thermal and package assembly information. [See Absolute Maximum Ratings, on page 40](#).
- Updated application circuit and BOM to align with latest reference designs. [See Applications, on page 66](#).
- Added dimensions to [Detailed Bottom View of 80-Pin eLQFP, on page 108](#)
- Added QFN and eLQFP package land patterns under [Recommended Land Patterns, on page 109](#)
- Added section [Related Collateral, on page 111](#)

Version 3 to Released, July 2014

- Updated Zarlink logo and name reference to Microsemi logo and name.

Information relating to products and services furnished herein by Microsemi Corporation or its subsidiaries (collectively "Microsemi") is believed to be reliable. However, Microsemi assumes no liability for errors that may appear in this publication, or for liability otherwise arising from the application or use of any such information, product or service or for any infringement of patents or other intellectual property rights owned by third parties which may result from such application or use. Neither the supply of such information or purchase of product or service conveys any license, either express or implied, under patents or other intellectual property rights owned by Microsemi or licensed from third parties by Microsemi, whatsoever. Purchasers of products are also hereby notified that the use of product in certain ways or in combination with Microsemi, or non-Microsemi furnished goods or services may infringe patents or other intellectual property rights owned by Microsemi.

This publication is issued to provide information only and (unless agreed by Microsemi in writing) may not be used, applied or reproduced for any purpose nor form part of any order or contract nor to be regarded as a representation relating to the products or services concerned. The products, their specifications, services and other information appearing in this publication are subject to change by Microsemi without notice. No warranty or guarantee express or implied is made regarding the capability, performance or suitability of any product or service. Information concerning possible methods of use is provided as a guide only and does not constitute any guarantee that such methods of use will be satisfactory in a specific piece of equipment. It is the user's responsibility to fully determine the performance and suitability of any equipment using such information and to ensure that any publication or data used is up to date and has not been superseded. Manufacturing does not necessarily include testing of all functions or parameters. These products are not suitable for use in any medical and other products whose failure to perform may result in significant injury or death to the user. All products and materials are sold and services provided subject to Microsemi's conditions of sale which are available on request.

For more information about all Microsemi products
visit our website at
www.microsemi.com

TECHNICAL DOCUMENTATION – NOT FOR RESALE



Microsemi Corporate Headquarters One
One Enterprise, Aliso Viejo CA 92656 USA
Within the USA: +1 (800) 713-4113
Outside the USA: +1 (949) 380-6100
Sales: +1 (949) 380-6136
Fax: +1 (949) 215-4996
E-mail: sales.support@microsemi.com

Microsemi Corporation (NASDAQ: MSCC) offers a comprehensive portfolio of semiconductor and system solutions for communications, defense and security, aerospace and industrial markets. Products include high-performance and radiation-hardened analog mixed-signal integrated circuits, FPGAs, SoCs and ASICs; power management products; timing and synchronization devices and precise time solutions, setting the world's standard for time; voice processing devices; RF solutions; discrete components; security technologies and scalable anti-tamper products; Power-over-Ethernet ICs and midspans; as well as custom design capabilities and services. Microsemi is headquartered in Aliso Viejo, Calif. and has approximately 3,400 employees globally. Learn more at www.microsemi.com.

© 2014 Microsemi Corporation. All rights reserved. Microsemi and the Microsemi logo are trademarks of Microsemi Corporation. All other trademarks and service marks are the property of their respective owners.

X-ON Electronics

Largest Supplier of Electrical and Electronic Components

Click to view similar products for [Telecom Interface ICs](#) category:

Click to view products by [Microchip](#) manufacturer:

Other Similar products are found below :

[MT8888CP1](#) [MT88E45BS1](#) [MT9174AN1](#) [MT88E39ASR1](#) [MT9074AL1](#) [MT9122AP1](#) [PEB4266TV12 S LL62](#) [DS3150TNC1+](#)
[DS26334GN+](#) [MT88E46AS1](#) [MT8963AE1](#) [DS26324GNA3+](#) [PM4351-RI](#) [PEF41068FV11 S LL8T](#) [PEF41068VV12 S LL8U](#)
[LE58QL022BVC](#) [LE58QL022BVCT](#) [LE88286DLC](#) [LE88276DLCT](#) [LE79252BTC](#) [RTL8019AS](#) [W7100A-S2E-100LQFP](#) [M100EVO-LITE](#)
[HE910NAR206T701](#) [XRT86VL38IB](#) [CMX631AD4](#) [XD8870](#) [82V2084PFG](#) [CPC5620A](#) [CPC5620ATR](#) [CPC5621A](#) [CPC5621ATR](#)
[CPC5622A](#) [CPC5622ATR](#) [DS21455+](#) [DS21348G+](#) [DS2148TN+](#) [CMX673E3](#) [LE88506DVC](#) [MT88E39AS1](#) [LE89810BSCT](#) [LE89810BSC](#)
[CMX673D4](#) [CMX683D4](#) [CMX602BD4](#) [MT8967AS1](#) [HC55185AIMZ](#) [MT8952BP1](#) [DS3150QN+](#) [DS2149Q+](#)