



**Connectivity Solutions for Embedded Design:**  
**USB, Ethernet, ZigBee®, MiWi™, CAN, LIN, IrDA®**  
**and RS-485 Protocols**

Wired and Wireless Connectivity Solutions



USB



Ethernet

ZigBee®



CAN



Easy to use ■ Low-cost solutions ■ Start designing today

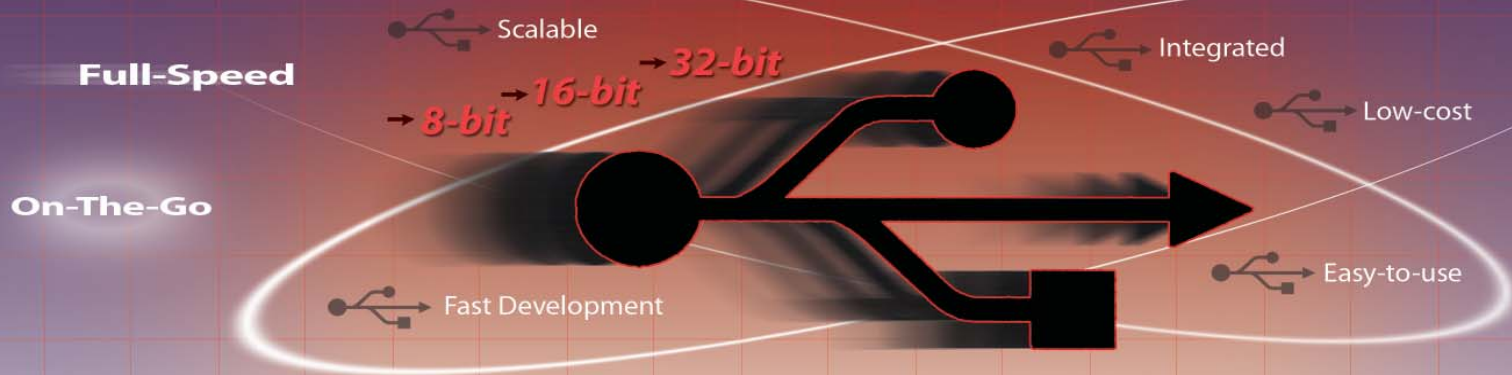

## Offering Scalable and Integrated Solutions for Full-Speed USB and USB On-The-Go

Consumers' desire for more engaging, easy-to-use and upgradable products is driving embedded designers to add USB capabilities to their products.

Microchip provides designers with a scalable choice of integrated USB solutions across 8-, 16- and 32-bit PIC® microcontrollers ranging from the space-saving 20-pin devices to the feature-rich 100-pin USB On-the-Go (OTG) products. This allows simple, compact designs to easily grow to more capable designs as requirements demand.

Memory offerings range from 16 Kbytes to 512 Kbytes of Flash program memory and from 768 bytes to 32 Kbytes of data RAM providing ample code and data space for complex USB applications. Microchip's USB product families include solutions for device, embedded host and dual-role OTG applications.

Microchip provides free source code for USB software stacks and class drivers to shorten development time for USB applications, including thumbdrive bootloaders and printer support. Microchip's free USB Host Stack, Device Stack and Class Drivers (HID, MSD, CDC, Custom) are available at [www.microchip.com/usb](http://www.microchip.com/usb).

Device	Core	USB	Flash	RAM	mTouch™ Support	UARTs	SPI	I <sup>2</sup> C™	Peripheral Pin Select	ADC	RTCC	Parallel Master Port	Analog Comp	Free SW Stacks	Free Class Drivers	Scalable Development Environment	Packages
PIC18F14K50	8-bit	USB 2.0 Device	16 KB	768B	Yes	1	1	1	No	10-bit, 9 Ch.	SW	No	2	Yes	Yes	Yes	20 pin
PIC18F4450/ 4550/4553	8-bit	USB 2.0 Device	Up to 32 KB	Up to 2048B	Yes External	1	1	1	No	10-bit, 10 & 13 Ch. 12-bit, 10 & 13 Ch.	SW	No	2	Yes	Yes	Yes	28, 40, 44 pin
PIC18F46J50	8-bit	USB 2.0 Device	64 KB	3904B	Yes CTMU	2	2	2	Yes	10-bit, 13 Ch.	Yes	Yes	2	Yes	Yes	Yes	28, 40, 44 pin
PIC18F87J50	8-bit	USB 2.0 Device	128 KB	3904B	Yes External	2	1	1	No	10-bit, 8 & 12 Ch.	SW	Yes	2	Yes	Yes	Yes	64, 80 pin
PIC24FJ64GB004	16-bit	USB 2.0 Device, Embedded Host, Dual Role, OTG	32 KB to 64 KB	8 KB	Yes CTMU	2	2	2	Yes	10-bit, 13 Ch.	Yes	Yes	3	Yes	Yes	Yes	28, 44 pin
PIC24FJ256GB110	16-bit	USB 2.0 Device, Embedded Host, Dual Role, OTG	64 KB to 256 KB	16 KB	Yes CTMU	4	3	3	Yes	10-bit, 16 Ch.	Yes	Yes	3	Yes	Yes	Yes	64, 80, 100 pin
PIC32MX4XX	32-bit	USB 2.0 Device, Embedded Host, Dual Role, OTG	512 KB	32 KB	Yes External	2	2	2	No	10-bit, 16 Ch.	Yes	Yes	2	Yes	Yes	Yes	64, 100 pin

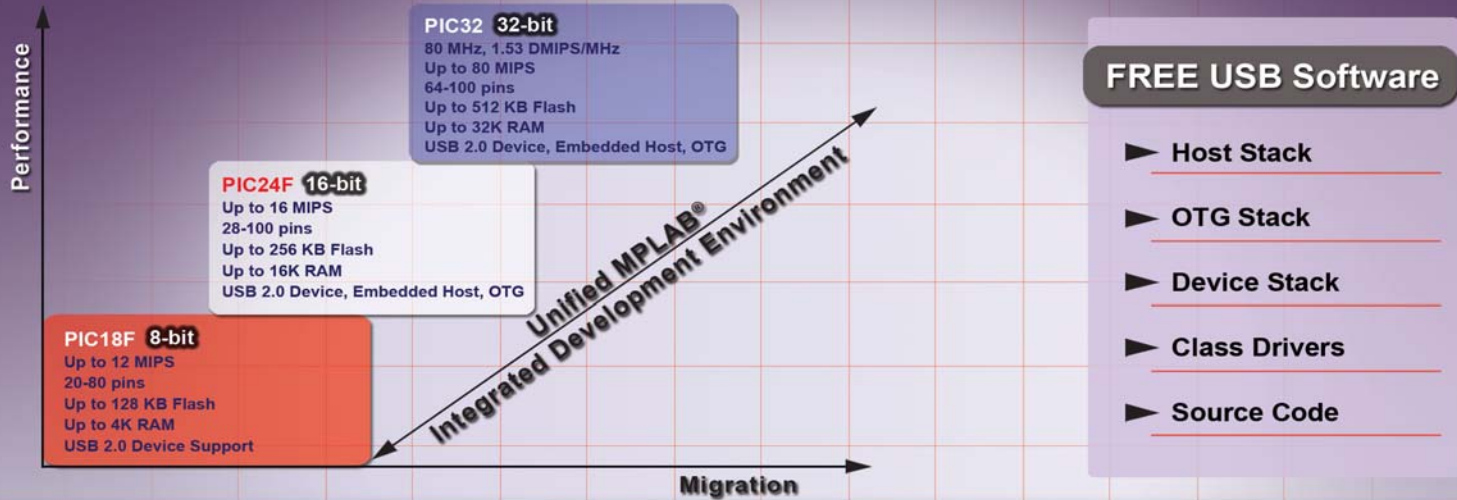

## USB Solutions Roadmap

### Expanding Family of USB PIC® Microcontrollers

The industry's strongest scalable products and software migration path

#### USB Development Tools and Software Support

Microchip's MPLAB® tools support all of the USB PIC microcontrollers. The PIC18F USB microcontroller solutions have dedicated development boards. The PIC24F and PIC32 series are pin and peripheral compatible and share the Explorer 16 development platform with their own USB Plug-in-Modules (PIMs).

Microchip's support for USB applications includes peripheral applications for the PIC18F family, and peripheral, embedded host and OTG applications for the PIC24F and PIC32. Designers can use Microchip's free USB stacks – including class drivers, 16- and 32-bit file system drivers and SCSI interface drivers – which are provided in source code form. These can be combined for inclusion into any USB application, such as thumb drives.

Additional software support includes full C and RTOS development environments. Also available are: TCP/IP stacks, graphics libraries and ZigBee software stacks, which allow USB functionality to be combined with other capabilities to support a variety of designs.

#### USB Starter Kits

Easy-to-use low-cost kits demonstrate the basics of USB designs using 8-, 16- and 32-bit PIC microcontrollers.



#### Starter Kit Order Numbers

PIC18F14K50	(DV164126)
PIC24FJ256GB110	(DM240011)
PIC32MX4XX	(DM320003)

#### PICDEM™ FS-USB Demonstration Board (DM163025)



This evaluation board supports the PIC18F4450 family.



#### Explorer 16 Development Board (DM240001)

A low-cost modular development system for Microchip's 16- and 32-bit microcontrollers.



#### USB Plug-in Modules (PIMs) for Explorer 16 Board

PIC24FJ256GB110 (MA240014), PIC24FJ64GB004 (MA240019), PIC32 (MA320002) These PIMs support Microchip's 16- and 32-bit microcontrollers.



#### USB PICTail™ Plus Daughter Board (AC164131)

Enables USB connectivity when using a PIC24 or PIC32 USB PIM in conjunction with the Explorer 16 board.



#### USB Plug-in Modules

PIC18F87J50 (MA180021), PIC18F46J50 (MA180024) These PIMs support Microchip's 8-bit microcontrollers.

#### USB Solutions Design Center [www.microchip.com/usb](http://www.microchip.com/usb)

- ▶ Getting Started
- ▶ Technical Documentation
- ▶ Programming Support
- ▶ FAQs – Design General
- ▶ Development Tools
- ▶ Circuit Diagrams
- ▶ Silicon Solutions
- ▶ Technical Training





Now offering the world's smallest  
Embedded Ethernet Controller and  
a single chip Ethernet PIC Microcontroller solution  
with free TCP/IP stack software



## Ethernet Solutions with Integrated MAC and PHY

Microchip addresses the growing demand for embedded Ethernet products with the ENC624J600, ENC424J600 and ENC28J60 as stand alone Ethernet controllers and with the PIC18F97J60 microcontroller, which are IEEE 802.3 compliant and fully compatible with 10/100/1000 Base-T networks. Microchip's Ethernet solution also includes:

- Free and robust TCP/IP stack that is optimized for the PIC18, PIC24 and PIC32 microcontroller and dsPIC® digital signal controller families ([www.microchip.com/ethernet](http://www.microchip.com/ethernet))
- Some of the supported protocols are: HTTP, SMTP, SNMP, FTP, SNTF, SSL, TCP, UDP, IP, DHCP, DDNS, ICMP and ARP

### PIC18F97J60 Ethernet PIC Microcontroller

- PIC18F microcontroller with built-in Ethernet MAC and 10 Base-T PHY
- 8 KB dedicated Ethernet Buffer RAM
- Up to 128 KB Flash
- Advanced analog and communication peripherals

### ENC624J600, ENC424J600 Embedded Ethernet Controllers

- Integrated MAC and 10/100 Base-T PHY
- 24 Kbyte transmit/receive buffer SRAM
- MCU Interface Supported: SPI and 8/16-bit parallel
- Cryptographic Security Engines
- Pre-programmed unique MAC address
- Available in 44-pin (TQFP and QFN) and 64-pin (TQFP) packages

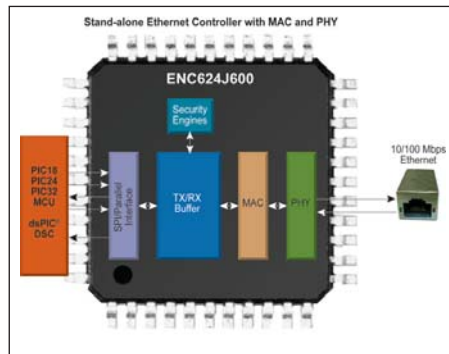

### MAC Address Chips – Solving Your MAC Address Needs

- Pre-programmed EUI-48™ and EUI-64™ node address
  - Up to 1.5 Kb Serial EEPROM functionality
  - SPI – 25AA02E48
  - I<sup>2</sup>C™ – 24AA02E48
  - UNI/O® – 11AA02E48
- [www.microchip.com/MAC](http://www.microchip.com/MAC)

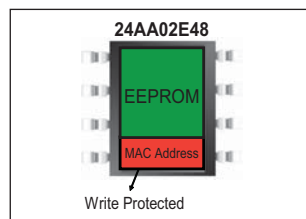

### ENC28J60 Embedded Ethernet Controller

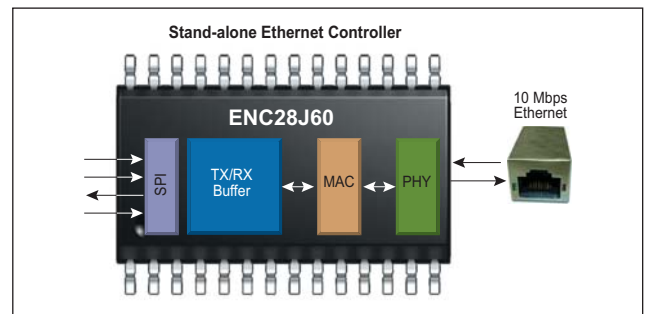

- Integrated MAC and 10 Base-T PHY
- 8 Kbyte transmit/receive buffer SRAM
- MCU Interface Supported: SPI
- Available in 28-pin SPDIP, SSOP, SOIC, QFN packages

### Development Tools Support

#### Fast 100 Mbps Ethernet PICtail™ Plus Daughter Board (AC164132)



Populated with the ENC624J600, this Ethernet board interfaces to the RJ-45 connector. It can be plugged into the Explorer 16 development board (DM240001) and the PIC18 Explorer board (DM183032) allowing connection to any of Microchip's 8, 16- and 32-bit products.

#### PICDEM.net™ 2 Development Board (DM163024)



This Ethernet development board supports both the ENC28J60 controller and the PIC18F97J60 MCU. With this board and Microchip's free TCP/IP stack, a web server can be developed showcasing the capability to remotely monitor and control embedded applications over the Internet.

#### Ethernet PICtail Plus Daughter Board (AC164123)



This Ethernet board is populated with the 28-pin ENC28J60 Ethernet controller which interfaces to the RJ-45 connector. It can be plugged into the Explorer 16 development board (DM240001), allowing connection to any of Microchip's 16- and 32-bit products when used in conjunction with the free Microchip TCP/IP stack.

Targeted to address the need for low data rate, low cost wireless sensor and control networks

## Wireless Solutions

Wireless communication technologies have been commonplace in homes and industry for many years. Recently, appliance and industrial markets and metering and thermostat applications have driven new demand for a standardized, low data rate, wireless technology that works well in remote sensor and control applications. As a result, the IEEE 802.15.4™ standard was developed to address this need.

### Easy implementation of a wireless radio node with ZigBee®/MiWi™/MiWi P2P

#### Start with a MRF24J40 Wireless Transceiver

- Integrates IEEE 802.15.4 MAC and PHY layers
- Includes AES hardware encryption engine
- SPI interface to a PIC microcontroller

#### Select a free ZigBee, MiWi or MiWi P2P software stack

- Free software available via click-thru license
- All 3 stacks are configurable and optimized for reduced code footprint

#### Add an 8-, 16- or 32-bit PIC Microcontroller

- Minimum 3 Kbytes of program memory for MiWi P2P Stack
- Minimum 7 Kbytes of program memory for MiWi Stack (RFD)
- Minimum 40 Kbytes of program memory for ZigBee Stack (RFD)
- Over 200 microcontrollers to choose from

**ZigBee** is a wireless protocol based on the IEEE 802.15.4 global standard, ensuring interoperability and reliable communication between various manufacturers' products. ZigBee is well-suited for a wide array of low power wireless networks.

**MiWi** and **MiWi Point-to-Point (P2P)** protocols are designed to provide lower cost, reduced functionality alternatives for customers who desire robust communication but do not need ZigBee interoperability or large Mesh networks.

Stack	Topography	Hops	Flash Size	PIC18	PIC24	PIC32
MiWi P2P <i>Proprietary</i>	Star/P2P	1	3K-9K	Yes	Yes	Yes
MiWi <i>Proprietary</i>	Star/Mesh	4	7K-17K	Yes	Yes	Yes
ZigBee <i>Certified</i>	Star/Mesh	Infinite	40K-96K	Yes	Yes	TBD

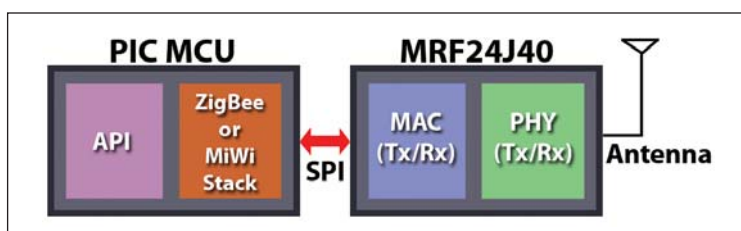

### Agency Certified Transceiver Module (MRF24J40MA-I/RM)



- RF design completed
- Optimized antenna
- FCC, ETSI, IC-Certified

### Development Tools Support

#### PICDEM™ Z 2.4 GHz Development Kit (DM163027-5)



- 2x MRF24J40MA RF daughter cards
- 2x PICDEM Z motherboards
- ZENA network analyzer board
- CD with documentation

#### ZENA™ Network Analyzer (DM183023)



- Graphically displays wireless network traffic
- Supports ZigBee, MiWi and MiWi P2P protocols

### Wireless Design Center [www.microchip.com/wireless](http://www.microchip.com/wireless)

- ▶ Getting Started
- ▶ Technical Documentation
- ▶ Programming Support
- ▶ FAQs – Design General
- ▶ Development Tools
- ▶ Circuit Diagrams
- ▶ Silicon Solutions
- ▶ Technical Training



## Controller Area Network (CAN)

Take your embedded design to the next level with Controller Area Network (CAN) bus solutions



## Local Interconnect Network (LIN/J2602)

Industry's first standard to address Class A open multiplexing protocols within vehicles

Take communication and connectivity in your deeply embedded design to the next level with Controller Area Network (CAN) and Local Interconnect Network (LIN) bus solutions from Microchip.

### Controller Area Network (CAN)

CAN has become the de facto standard for high integrity serial communication in deeply embedded applications. CAN supports multiple topologies, can be made deterministic and fault-tolerant, and transfers data at speeds up to 1 Mbps.

Microchip offers a complete line of products to meet the needs of high-performance embedded applications using the CAN protocol – including 8- and 16-bit microcontrollers and 16-bit digital signal controllers with integrated CAN, standalone CAN controllers, I/O expanders and CAN transceivers.

### Microchip's Enhanced CAN Module

At the heart of Microchip's CAN offering is the enhanced CAN module. Key features include:

- CAN 1.2, CAN 2.0A and CAN 2.0B support
- Up to 8 RX and 8 RX/TX buffers
- 16 full acceptance filters
- Up to 3 full acceptance mask filters
- Time stamping
- DMA support in 16-bit PIC24H PIC microcontrollers and dsPIC33F digital signal controllers
- DeviceNet™ support
- Legacy mode

### Local Interconnect Network (LIN)

LIN/J2602 is the industry's first standard designed to address low-cost networking within vehicles. LIN enables a cost-effective communication network for switch, smart sensor and actuator applications within the vehicle where the bandwidth and versatility of CAN is not required.

LIN can be implemented on any PIC microcontroller with a USART interface. Microchip also offers a robust physical layer interface, data link layer implementation and a variety of development aids including a LIN reference design.

### MCP202X LIN Transceivers

The MCP202X family of LIN transceivers integrates a LIN physical layer, internal voltage regulator and POR/BOR Reset function. LIN bus specification versions 1.3, 2.0 and 2.1 are supported. The devices are designed to meet the stringent EMC/ESD requirements of the world's automobile makers.



**Window Lift with Anti-Pinch Reference Design (APGRD002)**

### Popular CAN/LIN Products

Product Category	Device Example	CAN Controller	LIN Support
8-bit MCU	PIC16F690	N/A	EUSART Slave
8-bit MCU	PIC18F4680	8-bit Enhanced CAN Module	EUSART Master/Slave
16-bit MCU	PIC24HJ256GP506	16-bit Enhanced CAN Module	EUSART Master/Slave
16-bit DSC	dsPIC30F4012	Standard CAN Module	EUSART Master/Slave
16-bit DSC	dsPIC33FJ64MC502	16-bit Enhanced CAN Module	EUSART Master/Slave
Standalone CAN Controller	MCP2515	Standard CAN Module	Via SPI
CAN Transceiver	MCP2551	High-speed CAN Transceiver	N/A
CAN I/O Expander	MCP25050	N/A	N/A
LIN Transceiver	MCP2021	N/A	Physical Layer Interface

**RS-485** protocol enables longer distance between nodes and higher data rates

**IrDA®**

Offers additional interoperability with a wide range of devices including PDAs, cell phones and PCs

## CAN/LIN Development Tools

With easy-to-use development systems and application notes, Microchip provides a total CAN/LIN solution that enables low-risk product development, lower total system cost and faster time to market for high performance embedded designs. **Software stacks are also available from a number of third parties.**

## LIN Data Link Layer Firmware

LIN Data Link Layer firmware can be downloaded free-of-charge from Microchip's web site. Many third party companies also offer LIN Data Link Layer firmware, providing additional design options.

## Reference Designs

To alleviate customer design challenges, Microchip offers complete reference designs that integrate application software, Data Link Layer firmware and the Physical Layer to demonstrate a risk-free path for customers implementing real-time control networks.

## PICDEM™ CAN-LIN 3 Demonstration Board

(DM163015)



Microchip's PICDEM CAN-LIN 3 Demonstration Board is an easy way to discover the power of Microchip's CAN and LIN product offerings. Featuring three popular 8-bit PIC microcontrollers, the board simulates a pair of CAN nodes and a LIN sub-node.

## Other Connectivity Options

While the most sophisticated protocols and interfaces tend to garner a significant amount of attention, a number of simpler connectivity options are and will remain the embedded interconnects of choice for many deeply embedded applications. Microchip's focus on the embedded market ensures an ongoing commitment to support all of the connectivity solutions utilized by leading designers, including the microcontroller peripherals, application notes and software necessary to implement robust, highly reliable embedded networks.

### RS-485 Protocol

The RS-485 protocol is typically used as a more feature-rich alternative to RS-232. The protocol enables longer distance between nodes and higher data rates. Any PIC microcontroller with an on-board UART can support RS-485 communication. Many PIC microcontrollers include enhanced peripherals with an RS-485 mode.

### IrDA® Protocol

The IrDA protocol provides many portable devices with an affordable, short distance optical data communications link. IrDA can be implemented using the timers and I/Os found on any PIC microcontroller. Microchip's 16- and 32-bit products include IrDA encoder and decoder logic to enable easy implementation of the protocol.

### IrDA PICTail™ Plus Daughter Board (AC164124)



Enables IrDA connectivity when used with the Explorer 16 board (DM240001)

## Connectivity Solutions Design Center

[www.microchip.com/connectivity](http://www.microchip.com/connectivity)

- ▶ Getting Started
- ▶ Technical Documentation
- ▶ Programming Support
- ▶ FAQs – Design General
- ▶ Development Tools
- ▶ Circuit Diagrams
- ▶ Silicon Solutions
- ▶ Technical Training

## Support

Microchip is committed to supporting its customers in developing products faster and more efficiently. We maintain a worldwide network of field applications engineers and technical support ready to provide product and system assistance. In addition, the following service areas are available at [www.microchip.com](http://www.microchip.com):

- **Support** link provides a way to get questions answered fast: <http://support.microchip.com>
- **Sample** link offers evaluation samples of any Microchip device: <http://sample.microchip.com>
- **Forum** link provides access to knowledge base and peer help: <http://forum.microchip.com>
- **Buy** link provides locations of Microchip Sales Channel Partners: [www.microchip.com/sales](http://www.microchip.com/sales)

## Sales Office Listing

### AMERICAS

#### Atlanta

Tel: 678-957-9614

#### Boston

Tel: 774-760-0087

#### Chicago

Tel: 630-285-0071

#### Cleveland

Tel: 216-447-0464

#### Dallas

Tel: 972-818-7423

#### Detroit

Tel: 248-538-2250

#### Kokomo

Tel: 765-864-8360

#### Los Angeles

Tel: 949-462-9523

#### Santa Clara

Tel: 408-961-6444

#### Toronto

Mississauga, Ontario

Tel: 905-673-0699

### EUROPE

#### Austria - Wels

Tel: 43-7242-2244-39

#### Denmark - Copenhagen

Tel: 45-4450-2828

#### France - Paris

Tel: 33-1-69-53-63-20

#### Germany - Munich

Tel: 49-89-627-144-0

#### Italy - Milan

Tel: 39-0331-742611

#### Netherlands - Drunen

Tel: 31-416-690399

#### Spain - Madrid

Tel: 34-91-708-08-90

#### UK - Wokingham

Tel: 44-118-921-5869

## Training

If additional training interests you, then Microchip can help. We continue to expand our technical training options, offering a growing list of courses and in-depth curriculum locally, as well as significant online resources – whenever you want to use them.

- Regional Training Centers: [www.microchip.com/rtc](http://www.microchip.com/rtc)
- MASTERS Conferences: [www.microchip.com/masters](http://www.microchip.com/masters)
- Worldwide Seminars: [www.microchip.com/seminars](http://www.microchip.com/seminars)
- eLearning: [www.microchip.com/webseminars](http://www.microchip.com/webseminars)
- Resources from our Distribution and Third Party Partners [www.microchip.com/training](http://www.microchip.com/training)

### ASIA/PACIFIC

#### Australia - Sydney

Tel: 61-2-9868-6733

#### China - Beijing

Tel: 86-10-8528-2100

#### China - Chengdu

Tel: 86-28-8665-5511

#### China - Hong Kong SAR

Tel: 852-2401-1200

#### China - Nanjing

Tel: 86-25-8473-2460

#### China - Qingdao

Tel: 86-532-8502-7355

#### China - Shanghai

Tel: 86-21-5407-5533

#### China - Shenyang

Tel: 86-24-2334-2829

#### China - Shenzhen

Tel: 86-755-8203-2660

#### China - Wuhan

Tel: 86-27-5980-5300

#### China - Xiamen

Tel: 86-592-2388138

#### China - Xian

Tel: 86-29-8833-7252

#### China - Zhuhai

Tel: 86-756-3210040

### ASIA/PACIFIC

#### India - Bangalore

Tel: 91-80-3090-4444

#### India - New Delhi

Tel: 91-11-4160-8631

#### India - Pune

Tel: 91-20-2566-1512

#### Japan - Yokohama

Tel: 81-45-471- 6166

#### Korea - Daegu

Tel: 82-53-744-4301

#### Korea - Seoul

Tel: 82-2-554-7200

#### Malaysia - Kuala Lumpur

Tel: 60-3-6201-9857

#### Malaysia - Penang

Tel: 60-4-227-8870

#### Philippines - Manila

Tel: 63-2-634-9065

#### Singapore

Tel: 65-6334-8870

#### Taiwan - Hsin Chu

Tel: 886-3-6578-3000

#### Taiwan - Kaohsiung

Tel: 886-7-536-4818

#### Taiwan - Taipei

Tel: 886-2-2500-6610

#### Thailand - Bangkok

Tel: 66-2-694-1351

3/26/09

Microcontrollers • Digital Signal Controllers • Analog • Serial EEPROMs

The Microchip name and logo, the Microchip logo, dsPIC, MPLAB and PIC are registered trademarks of Microchip Technology Incorporated in the U.S.A. and other countries. MiWi, PICDEM, PICDEM.net and PICtail are trademarks of Microchip Technology Incorporated in the U.S.A. and other countries. All other trademarks mentioned herein are property of their respective companies.

© 2009, Microchip Technology Incorporated, All Rights Reserved. Printed in the U.S.A. 63/09  
DS01181E



**MICROCHIP**  
[www.microchip.com](http://www.microchip.com)

Microchip Technology Inc.  
2355 W. Chandler Blvd.  
Chandler, AZ 85224-6199



## X-ON Electronics

Largest Supplier of Electrical and Electronic Components

*Click to view similar products for [Daughter Cards & OEM Boards](#) category:*

*Click to view products by [Microchip](#) manufacturer:*

Other Similar products are found below :

[ADZS-21262-1-EZEXT](#) [27911](#) [SPC56ELADPT144S](#) [TMDXRM46CNCD](#) [DM160216](#) [EV-ADUCM350GPIOHZ](#) [EV-ADUCM350-BIO3Z](#)  
[ATSTK521](#) [1130](#) [MA160015](#) [MA180033](#) [MA240013](#) [MA240026](#) [MA320014](#) [MA330014](#) [MA330017](#) [TLK10034SMAEVM](#) [MIKROE-](#)  
[2152](#) [MIKROE-2154](#) [MIKROE-2381](#) [TSSOP20EV](#) [DEV-11723](#) [MIKROE-1108](#) [MIKROE-1516](#) [SPS-READER-GEVK](#) [AC244049](#)  
[AC244050](#) [AC320004-3](#) [2077](#) [ATSMARTCARD-XPRO](#) [EIC - Q600 -230](#) [ATZB-212B-XPRO](#) [SPC560PADPT100S](#) [SPC560BADPT64S](#)  
[MA180018](#) [EIC - Q600 -220](#) [AC164134-1](#) [BOB-12035](#) [STM8/128-D/RAIS](#) [AC164127-6](#) [AC164127-4](#) [AC164134-3](#) [AC164156](#) [MA320021](#)  
[MA320024](#) [DFR0285](#) [DFR0312](#) [DFR0356](#) [MA320023](#) [MIKROE-2564](#)