ATSAME54 100-Pin Motor Control Plug-In Module Information Sheet

Introduction

The ATSAME54 100-Pin Motor Control Plug-in Module (PIM), MA320207, is designed to demonstrate the capabilities of the ATSAME54 128-pin Motor Control devices using external op amps with the following hardware:

- The dsPICDEM™ MCLV-2 development board (DM330021-2)
- The dsPICDEM™ MCHV-3 development board (DM330023-3)

Both development boards support 100-pin PIM interfaces. The ATSAME54 Motor Control PIM is designed to use on board external op amps for signal conditioning of analog feedback inputs.

For the dsPICDEM™ MCLV-2 development board, insert the external op amp configuration board (included with the development board) at header J14.

For the dsPICDEM™ MCHV-3 development board, insert the PFC-EXT-OPAMP configuration board (included with the development board) at header J4.

Figure 1. Op amp Configuration Board for dsPICDEM™ MCLV-2



Figure 2. Op amp Configuration Board for dsPICDEM™ MCHV-3

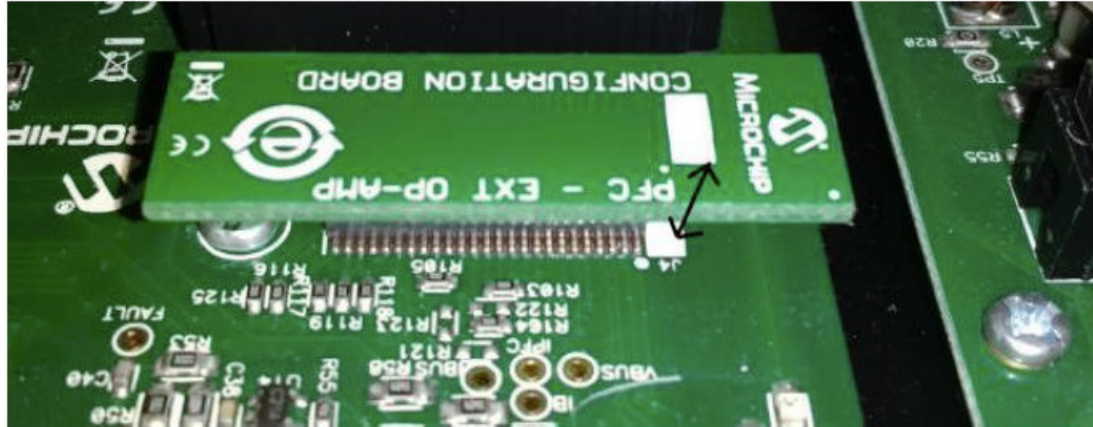

Do not connect non-isolated oscilloscope probes to probe any traces while using the PIM with the dsPICDEM MCHV-3 development boards. Instead, use a high-voltage differential probe, rated in excess of 600 VRMS (Common mode). Failure to heed this warning could result in hardware damage.

Programming and Debugging:

Use the following options to program and debug software on the ATSAME54 Motor Control PIM:

1. In-Circuit Debugger : The ATSAME54 Motor Control PIM can be programmed and debugged using the following debugging tools, which are connected to the board using a CoreSight 10 connector:
 - 1.1. MPLAB® ICD4 In-Circuit Debugger
 - 1.2. ATMEL-ICE
 - 1.3. SAM-ICE™
2. Isolated EDBG Interface (AC320202): This daughter board provides an isolated programming and debugging interface for the ATSAME54 Motor Control PIM. This daughter board is compatible with the dsPICDEM™ MCHV-2/ MCHV-3 boards. Refer to the information sheet of this daughter board for additional information.

1. PIM to MCU Mapping

The following table provides the static mapping between the 100-pin PIM pins and the 128-pin device pins.

Table 1-1. PIM to MCU Mapping

PIM Connector PIN	MCLV2 100-pin connection		MCHV3 100-pin connection			SAME54 MCU Pin	MCU Pin
	Pin Name	Functionality	Pin Name	Functionality	100-pin connector signal name		
1	DBG_LED2	Debug LED 2	DBG_LED1	Debug LED 1	LED2	PB26_LED	102
2	VDD	NC	VDD	NC	VDD	-	32,37,46,54, 65,79,91, 97,107,118
3	PWM1H3	PWM Output - 3H	PWM1H3	PWM Output - 3H	PWM1H3	PA10_TCC0_WH	35
4	NC	NC	NC	NC	NC	-	-
5	NC	NC	NC	NC	NC	-	-
6	NC	NC	NC	NC	NC	-	-
7	NC	NC	NC	NC	NC	-	-
8	NC	NC	NC	NC	NC	-	-
9	NC	NC	NC	NC	NC	-	-
10	NC	NC	NC	NC	NC	-	-
11	NC	NC	NC	NC	NC	-	-
12	NC	NC	NC	NC	NC	-	-
13	MCLR	Device Master Clear	MCLR	Device Master Clear	nRESET	nRESET	114
14	NC	NC	NC	NC	NC	-	-
15	VSS	NC	VSS	NC	VSS	-	5,31,38,45, 53,64,78,90, 96,106,116
16	VDD	NC	VDD	NC	VDD	-	32,37,46,54, 65,79,91, 97,107,118
17	NC	NC	NC	NC	NC	-	-
18	FAULT	DC bus Current Fault (active low logic)	FAULT	DC bus Current Fault (active low logic)	FAULT_PWM	PB02_EXT2_FAULT_PWM	127
19	TX	UART Transmit	PFC_FLT	IPFC Fault (overvoltage or overcurrent)	PFC_EN_FLT	PB03_EXT3_PFCFLT_PFCEN	128
20	PIM_V_M3	Voltage feedback signal	PIM_INDX/POT/V_M3	Hall Sensor/Current Sense/Voltage Feedback Signal	NA	-	-
21	PIM_V_M2	Voltage feedback signal	PIM_QEB/IB/V_M2	Hall Sensor/Current Sense/Voltage Feedback Signal	NA	-	-
22	PIM_V_M1	Voltage feedback signal	PIM_QEA/IA/V_M1	Hall Sensor/Current Sense/Voltage Feedback Signal	NA	-	-
23	PIM_IMOTOR_SUM	DC bus current signal	PIM_IBUS/VBUS	DC Bus Voltage (downscaled)	VDCBUS2	PA07_ADC0_CH7_VDC_ISHUNT	24
24	PIM_IMOTOR2	Phase current signal	PIM_IB/POT	AC Input Zero Cross/AC Input Voltage (downscaled)/ Potentiometer	NA	-	-

ATSAME54

PIM to MCU Mapping

.....continued

PIM Connector PIN	MCLV2 100-pin connection		MCHV3 100-pin connection			SAME54 MCU Pin	MCU Pin
	Pin Name	Functionality	Pin Name	Functionality	100-pin connector signal name		
25	PIM_IMOTOR1	Phase current signal	PIM_IA/IPFC	PFC Current (buffered)	NA	-	-
26	PGC	Device programming clock line	PGC	Device programming clock line	SWCLK	PA30_SWCLK	119
27	PGD	Device programming data line	PGD	Device programming data line	SWDIO	PA31_SWDIO	120
28	VREF	Reference voltage (half of AVDD voltage)	AVDD/2	Reference voltage (half of AVDD voltage)	VREF	-	-
29	PIM_REC_NEUTR	Reconstructed motor neutral line voltage	PIM_REC_NEUTR	Reconstructed motor neutral line voltage	NEUTR	PA05_ADC0_CH5_REC_NEUTR	22
30	AVDD	Analog supply	AVDD	Analog supply	AVDD	VDDANA	6,15,26
31	AVSS	Analog supply	AVSS	Analog supply	GND	GNDANA	14,25
32	PIM_POT	Potentiometer signal	PIM_POT	Potentiometer signal	PIM_POT	PA06_ADC0_CH6_PIM_POT	23
33	NC	NC	PIM_POT	Potentiometer signal	NC	-	-
34	PIM_GEN2	General I/O	PIM_GEN2	General I/O	NC	-	-
35	PIM_VBUS	DC bus voltage (downscaled)	PIM_VBUS	DC bus voltage (downscaled)	VDCBUS1	PB01_ADC0_CH13_VBUS PD00_ADC1_CH14_VBUS	126, 13
36	VSS	NC	VSS	NC	VSS	-	5,31,38,45, 53,64,78, 90,96,106,116
37	VDD	NC	VDD	NC	VDD	-	32,37,46,54, 65,79,91, 97,107,118
38	NC	NC	PIM_VAC_VOL2	AC Input Voltage (unbuffered)	NC	-	-
39	NC	NC		PFC Shunt Signal	NC	-	-
40	NC	NC	PIM_PFC_L	PFC Shunt Signal	NC	-	-
41	PIM_MONITOR_1	Hall Sensor/Current Sense/Voltage Feedback Signal	PIM_V_M1/POT	Hall Sensor/Current Sense/Voltage Feedback Signal	PIM_MONITOR_1	PA02_ADC0_CH0_UpH	9
42	PIM_MONITOR_2	Hall Sensor/Current Sense/Voltage Feedback Signal	PIM_V_M2	Hall Sensor/Current Sense/Voltage Feedback Signal	PIM_MONITOR_2	PB08_ADC0_CH2_ADC1_CH0_VPh	19
43	PIM_MONITOR_3	Hall Sensor/Current Sense/Voltage Feedback Signal	PIM_V_M3/IBUS	Hall Sensor/Current Sense/Voltage Feedback Signal	PIM_MONITOR_3	PB09_ADC0_CH3_ADC1_CH1_ISHUNT; PC03_ADC1_CH5_ISHUNT	20, 8
44	NC	NC	NC	NC	NC	-	-
45	VSS	NC	VSS	NC	VSS	-	5,31,38,45, 53,64,78, 90,96,106,116
46	VDD	NC	VDD	NC	VDD	-	32,37,46,54, 65,79,91, 97,107,118
47	HALLB	Hall sensor /QEI input	HB/QEB	Hall sensor /QEI input	HALLB_QEB	PC17_PDEC_QD1_HALL_ENCB	71

ATSAME54

PIM to MCU Mapping

.....continued

PIM Connector PIN	MCLV2 100-pin connection		MCHV3 100-pin connection			SAME54 MCU Pin	MCU Pin
	Pin Name	Functionality	Pin Name	Functionality	100-pin connector signal name		
48	HALLC	Hall sensor /QEI input	HC/INDX	Hall sensor /QEI input	HALLC_QINDX	PC18_PDEC_QDI2_HALL_ENCZ	72
49	RX	UART Receive	RX	UART Receive	URXD0	PA13_URXD0_SER2_PAD1	61
50	TX	UART Transmit	TX	UART Transmit	UTXD0	PA12_UTXD0_SER2_PAD0	60
51	USB_TX	UART Transmit (connected directly to U7)	NC	NC	NC	-	-
52	USB_RX	UART Receive (connected directly to U7)	NC	NC	NC	-	-
53	NC	NC	NC	NC	NC	-	-
54	NC	NC	NC	NC	NC	-	-
55	NC	NC	NC	NC	NC	-	-
56	NC	NC	NC	NC	NC	-	-
57	NC	NC	NC	NC	NC	-	-
58	PIM_FLT_OUT2	General I/O	PIM_FLT_OUT2 (VACZC)	General I/O	PFC_VACZC	PA11_ADC0_CH11_PFCVACZC_IA; PB05_ADC1_CH7_PFCVACZC_IA	36, 12
59	PIM_FLT_OUT1	General I/O	PIM_FLT_OUT1 (IPFC)	General I/O	PFC_I	PB00_ADC0_CH12_IPFC_IB; PC30_ADC1_CH12_IPFC_IB	125, 123
60	DBG_LED1	Debug LED 1	DBG_LED2	Debug LED 2	LED1	PB27_LED	103
61	HOME	Home signal for QEI	HOME	Home signal for QEI	NC	-	-
62	VDD	NC	VDD	NC	VDD	-	32,37,46,54, 65,79,91, 97,107,118
63	OSC1/CLKO	Crystal oscillator in	OSCI	Crystal oscillator in	NC	-	-
64	OSC2/CLKI	Crystal oscillator out	OSCO	Crystal oscillator out	NC	-	-
65	VSS	NC	VSS	NC	VSS	-	5,31,38,45, 53,64,78,90, 96,106,116
66	PIM_IBUS+	Bus current shunt signal	PIM_IBUS+	Bus current shunt signal	NC	-	-
67	PIM_IBUS-	Bus current shunt signal	PIM_IBUS-	Bus current shunt signal	NC	-	-
68	LIN_CS	LIN Chip Select signal	BTN	Push Button	BTN	PD08_BTN	47
69	LIN_FAULT	LIN Fault signal	NC	NC	NC	-	-
70	RX	UART Receive	RX	UART Receive	NC	-	-
71	NC	NC	PIM_PFC_PWM	PFC PWM Output	NC	-	-
72	USB_RX	UART Receive (connected directly to U7)	HA/QEA	Hall Sensor /QEI Input	NC	-	-
73	PIM_IB+	IMOTOR1 shunt signal	PIM_IB+	IB Shunt Signal	NC	-	-
74	PIM_IA+	IMOTOR2 shunt signal	PIM_IA+	IA Shunt Signal	NC	-	-

ATSAME54

PIM to MCU Mapping

.....continued

PIM Connector PIN	MCLV2 100-pin connection		MCHV3 100-pin connection			SAME54 MCU Pin	MCU Pin
	Pin Name	Functionality	Pin Name	Functionality	100-pin connector signal name		
75	VSS	NC	VSS	NC	VSS	-	5,31,38, 45,53,64,78, 90,96,106,116
76	USB_TX	UART Transmit (connected directly to U7)	HB/QEB	Hall Sensor /QEI Input	NC	-	-
77	CAN_TX	CAN Transmit	PIM_HALLC/INDX/STP_PWM	Hall Sensor /QEI Input	NC	-	-
78	CAN_RX	CAN Receive	PIM_PFC_PWM	PFC PWM Output	PFC_PWM	PC14_TCC1_WO0_PFC_PWM	58
79	NC	NC	VACZX	AC Input Zero Cross	NC	-	-
80	HALLA	Hall sensor /QEI input	HA/QEA	Hall Sensor /QEI Input	HALLA_QEA	PC16_PDEC_QDIO_HALL_ENCA	70
81	NC	NC	NC	NC	NC	-	-
82	PIM_GEN1	General I/O	PIM_GEN1	General I/O	NC	-	-
83	BTN_1	Push-button S2 input	NC	NC	BTN1	PD09_BTN1	48
84	BTN_2	Push-button S3 input	TX	UART Transmit	BTN2	PD10_BTN2	49
85	NC	NC	NC	NC	NC	-	-
86	VDD	NC	VDD	NC	VDD	-	32,37,46,54, 65,79,91, 97,107,118
87	CAN_RX	CAN Receive	NC	NC	CAN_RX	PB13_CAN_RX	42
88	CAN_TX	CAN Transmit	NC	NC	CAN_TX	PB12_CAN_TX	41
89	NC	NC	NC	NC	NC	-	-
90	NC	NC	NC	NC	NC	-	-
91	NC	NC	NC	NC	NC	-	-
92	NC	NC	NC	NC	NC	-	-
93	PWM1L1	PWM Output - 1L	PWM1L1	PWM Output - 1L	PWM1L1	PA16_TCC0_UL	66
94	PWM1H1	PWM Output - 1H	PWM1H1	PWM Output - 1H	PWM1H1	PA08_TCC0_UH	33
95	NC	NC	NC	NC	NC	-	-
96	NC	NC	NC	NC	NC	-	-
97	NC	NC	NC	NC	NC	-	-
98	PWM1L2	PWM Output - 2L	PWM1L2	PWM Output - 2L	PWM1L2	PA17_TCC0_VL	67
99	PWM1H2	PWM Output - 2H	PWM1H2	PWM Output - 2H	PWM1H2	PA09_TCC0_VH	34
100	PWM1L3	PWM Output - 3L	PWM1L3	PWM Output - 3L	PWM1L3	PA18_TCC0_WL	68

Figure 1-1. ATSAME54 Motor Control PIM Schematic

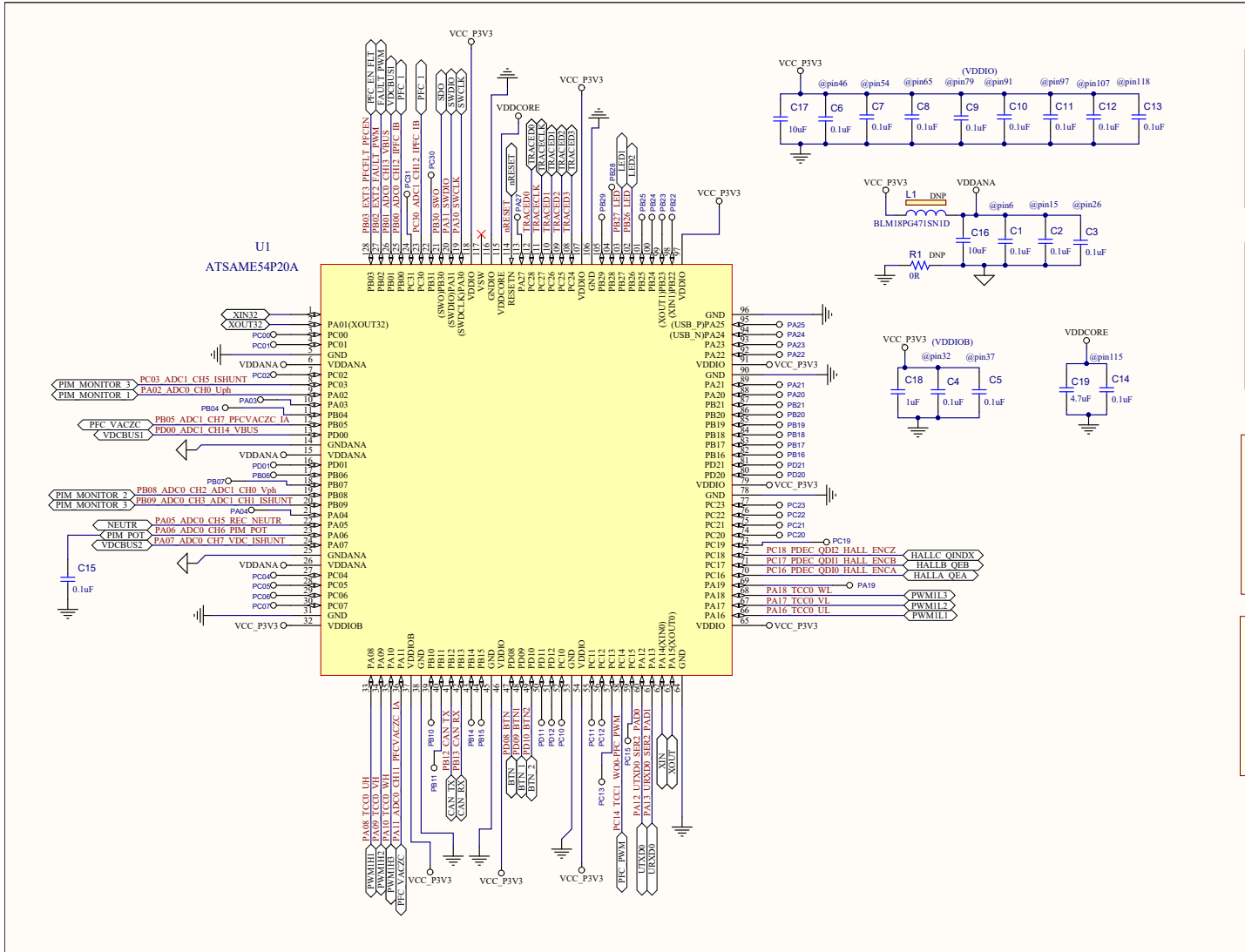

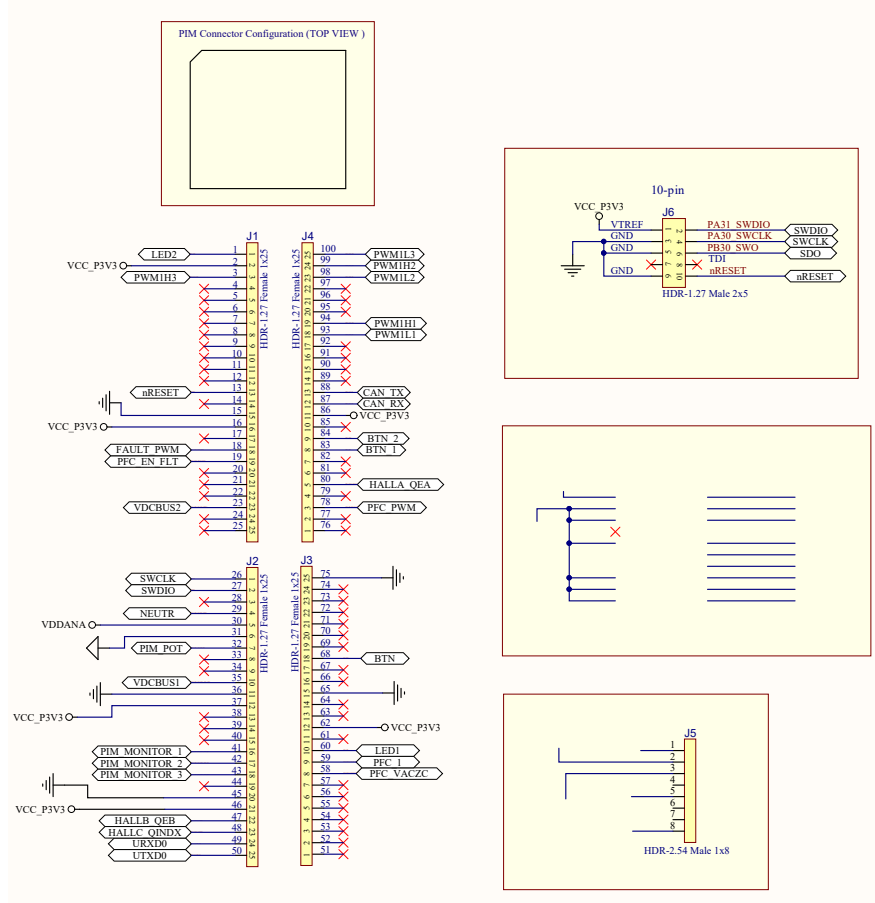

ATSAME54

PIM to MCU Mapping

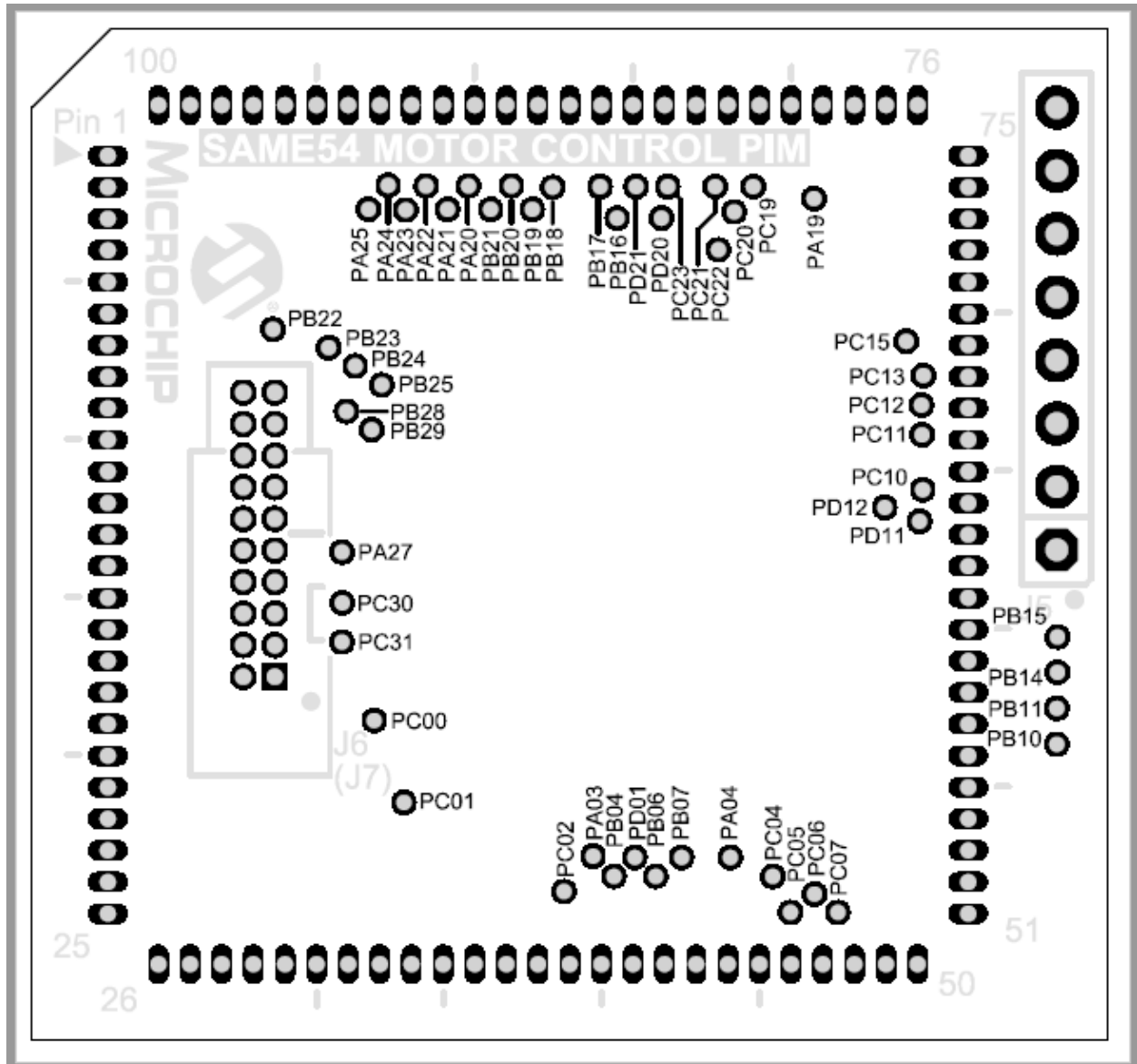

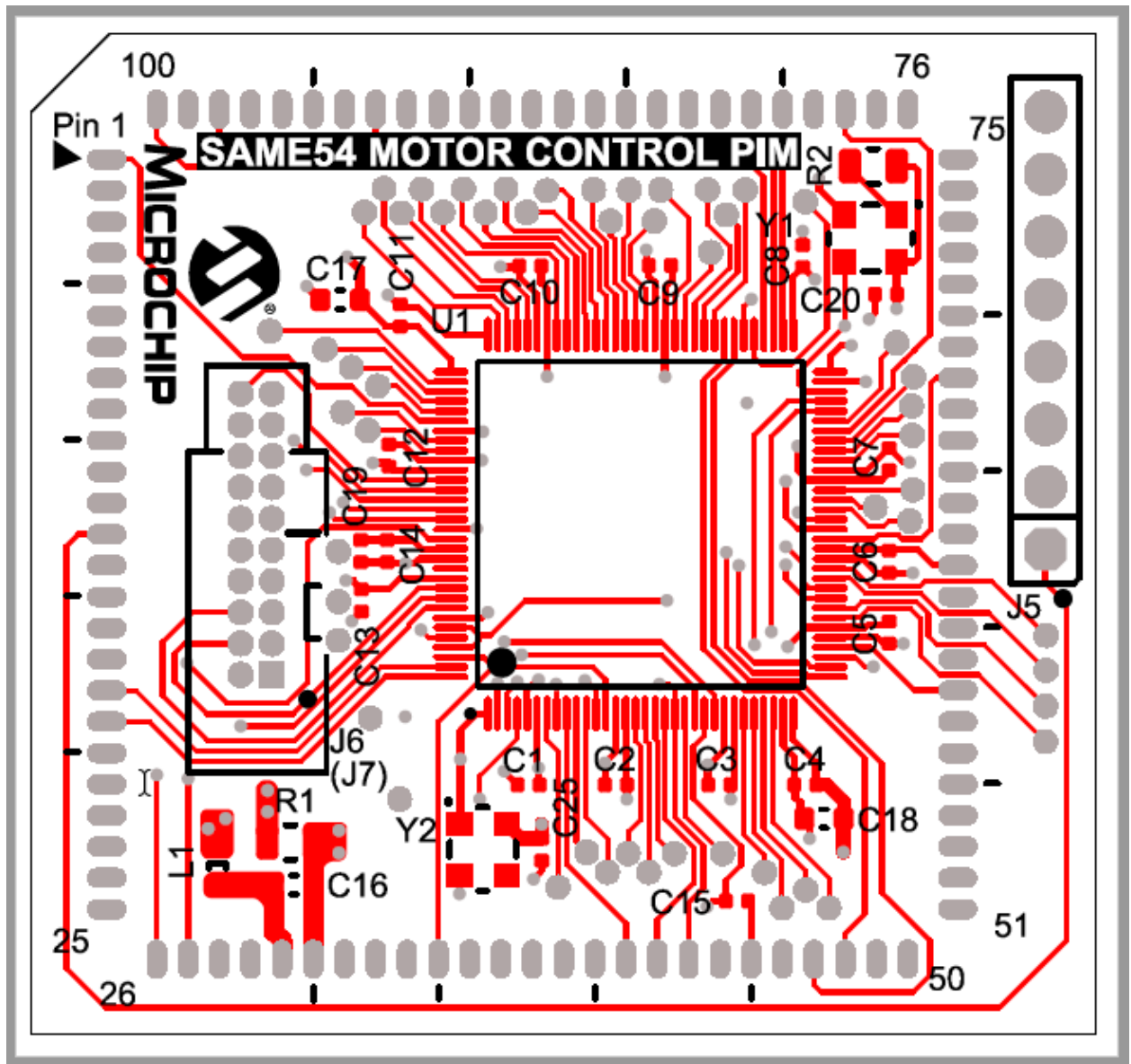

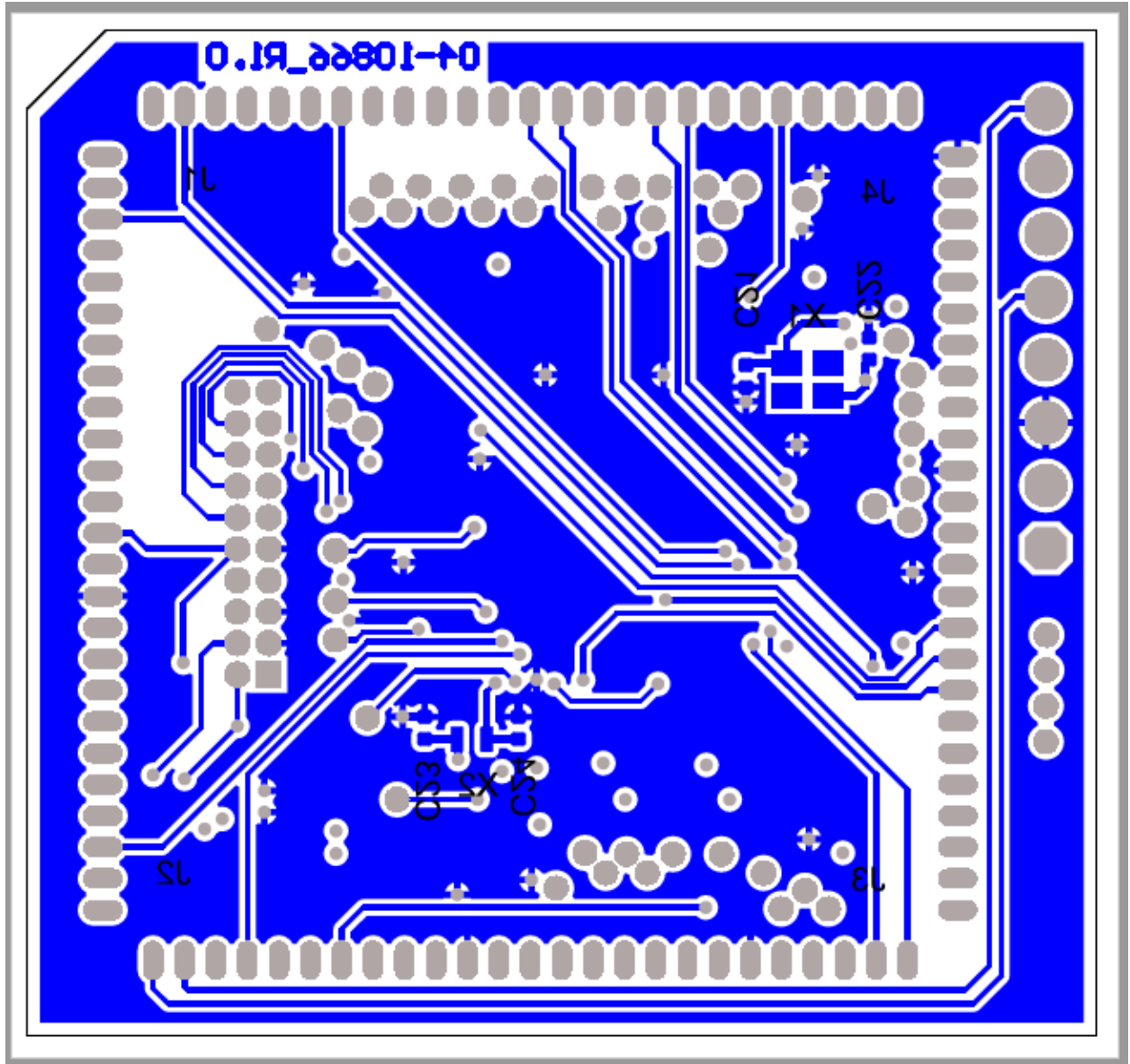

The Microchip Web Site

Microchip provides online support via our web site at <http://www.microchip.com/>. This web site is used as a means to make files and information easily available to customers. Accessible by using your favorite Internet browser, the web site contains the following information:

- **Product Support** – Data sheets and errata, application notes and sample programs, design resources, user's guides and hardware support documents, latest software releases and archived software
- **General Technical Support** – Frequently Asked Questions (FAQ), technical support requests, online discussion groups, Microchip consultant program member listing
- **Business of Microchip** – Product selector and ordering guides, latest Microchip press releases, listing of seminars and events, listings of Microchip sales offices, distributors and factory representatives

Customer Change Notification Service

Microchip's customer notification service helps keep customers current on Microchip products. Subscribers will receive e-mail notification whenever there are changes, updates, revisions or errata related to a specified product family or development tool of interest.

To register, access the Microchip web site at <http://www.microchip.com/>. Under "Support", click on "Customer Change Notification" and follow the registration instructions.

Customer Support

Users of Microchip products can receive assistance through several channels:

- Distributor or Representative
- Local Sales Office
- Field Application Engineer (FAE)
- Technical Support

Customers should contact their distributor, representative or Field Application Engineer (FAE) for support. Local sales offices are also available to help customers. A listing of sales offices and locations is included in the back of this document.

Technical support is available through the web site at: <http://www.microchip.com/support>

Microchip Devices Code Protection Feature

Note the following details of the code protection feature on Microchip devices:

- Microchip products meet the specification contained in their particular Microchip Data Sheet.
- Microchip believes that its family of products is one of the most secure families of its kind on the market today, when used in the intended manner and under normal conditions.
- There are dishonest and possibly illegal methods used to breach the code protection feature. All of these methods, to our knowledge, require using the Microchip products in a manner outside the operating specifications contained in Microchip's Data Sheets. Most likely, the person doing so is engaged in theft of intellectual property.
- Microchip is willing to work with the customer who is concerned about the integrity of their code.

- Neither Microchip nor any other semiconductor manufacturer can guarantee the security of their code. Code protection does not mean that we are guaranteeing the product as “unbreakable.”

Code protection is constantly evolving. We at Microchip are committed to continuously improving the code protection features of our products. Attempts to break Microchip’s code protection feature may be a violation of the Digital Millennium Copyright Act. If such acts allow unauthorized access to your software or other copyrighted work, you may have a right to sue for relief under that Act.

Legal Notice

Information contained in this publication regarding device applications and the like is provided only for your convenience and may be superseded by updates. It is your responsibility to ensure that your application meets with your specifications. MICROCHIP MAKES NO REPRESENTATIONS OR WARRANTIES OF ANY KIND WHETHER EXPRESS OR IMPLIED, WRITTEN OR ORAL, STATUTORY OR OTHERWISE, RELATED TO THE INFORMATION, INCLUDING BUT NOT LIMITED TO ITS CONDITION, QUALITY, PERFORMANCE, MERCHANTABILITY OR FITNESS FOR PURPOSE. Microchip disclaims all liability arising from this information and its use. Use of Microchip devices in life support and/or safety applications is entirely at the buyer’s risk, and the buyer agrees to defend, indemnify and hold harmless Microchip from any and all damages, claims, suits, or expenses resulting from such use. No licenses are conveyed, implicitly or otherwise, under any Microchip intellectual property rights unless otherwise stated.

Trademarks

The Microchip name and logo, the Microchip logo, AnyRate, AVR, AVR logo, AVR Freaks, BitCloud, chipKIT, chipKIT logo, CryptoMemory, CryptoRF, dsPIC, FlashFlex, flexPWR, Heldo, JukeBlox, KeeLoq, Klear, LANCheck, LINK MD, maXStylus, maXTouch, MediaLB, megaAVR, MOST, MOST logo, MPLAB, OptoLyzer, PIC, picoPower, PICSTART, PIC32 logo, Prochip Designer, QTouch, SAM-BA, SpyNIC, SST, SST Logo, SuperFlash, tinyAVR, UNI/O, and XMEGA are registered trademarks of Microchip Technology Incorporated in the U.S.A. and other countries.

ClockWorks, The Embedded Control Solutions Company, EtherSynch, Hyper Speed Control, HyperLight Load, IntelliMOS, mTouch, Precision Edge, and Quiet-Wire are registered trademarks of Microchip Technology Incorporated in the U.S.A.

Adjacent Key Suppression, AKS, Analog-for-the-Digital Age, Any Capacitor, AnyIn, AnyOut, BodyCom, CodeGuard, CryptoAuthentication, CryptoAutomotive, CryptoCompanion, CryptoController, dsPICDEM, dsPICDEM.net, Dynamic Average Matching, DAM, ECAN, EtherGREEN, In-Circuit Serial Programming, ICSP, INICnet, Inter-Chip Connectivity, JitterBlocker, KlearNet, KlearNet logo, memBrain, Mindi, MiWi, motorBench, MPASM, MPF, MPLAB Certified logo, MPLIB, MPLINK, MultiTRAK, NetDetach, Omniscient Code Generation, PICDEM, PICDEM.net, PICKit, PICtail, PowerSmart, PureSilicon, QMatrix, REAL ICE, Ripple Blocker, SAM-ICE, Serial Quad I/O, SMART-I.S., SQI, SuperSwitcher, SuperSwitcher II, Total Endurance, TSHARC, USBCheck, VariSense, ViewSpan, WiperLock, Wireless DNA, and ZENA are trademarks of Microchip Technology Incorporated in the U.S.A. and other countries.

SQTP is a service mark of Microchip Technology Incorporated in the U.S.A.

Silicon Storage Technology is a registered trademark of Microchip Technology Inc. in other countries.

GestIC is a registered trademark of Microchip Technology Germany II GmbH & Co. KG, a subsidiary of Microchip Technology Inc., in other countries.

All other trademarks mentioned herein are property of their respective companies.

© 2018, Microchip Technology Incorporated, Printed in the U.S.A., All Rights Reserved.

ISBN: 978-1-5224-3635-5

Quality Management System Certified by DNV

ISO/TS 16949

Microchip received ISO/TS-16949:2009 certification for its worldwide headquarters, design and wafer fabrication facilities in Chandler and Tempe, Arizona; Gresham, Oregon and design centers in California and India. The Company's quality system processes and procedures are for its PIC[®] MCUs and dsPIC[®] DSCs, KEELOQ[®] code hopping devices, Serial EEPROMs, microperipherals, nonvolatile memory and analog products. In addition, Microchip's quality system for the design and manufacture of development systems is ISO 9001:2000 certified.

Worldwide Sales and Service

AMERICAS	ASIA/PACIFIC	ASIA/PACIFIC	EUROPE
<p>Corporate Office 2355 West Chandler Blvd. Chandler, AZ 85224-6199 Tel: 480-792-7200 Fax: 480-792-7277 Technical Support: http://www.microchip.com/support Web Address: www.microchip.com</p> <p>Atlanta Duluth, GA Tel: 678-957-9614 Fax: 678-957-1455</p> <p>Austin, TX Tel: 512-257-3370</p> <p>Boston Westborough, MA Tel: 774-760-0087 Fax: 774-760-0088</p> <p>Chicago Itasca, IL Tel: 630-285-0071 Fax: 630-285-0075</p> <p>Dallas Addison, TX Tel: 972-818-7423 Fax: 972-818-2924</p> <p>Detroit Novi, MI Tel: 248-848-4000</p> <p>Houston, TX Tel: 281-894-5983</p> <p>Indianapolis Noblesville, IN Tel: 317-773-8323 Fax: 317-773-5453 Tel: 317-536-2380</p> <p>Los Angeles Mission Viejo, CA Tel: 949-462-9523 Fax: 949-462-9608 Tel: 951-273-7800</p> <p>Raleigh, NC Tel: 919-844-7510</p> <p>New York, NY Tel: 631-435-6000</p> <p>San Jose, CA Tel: 408-735-9110 Tel: 408-436-4270</p> <p>Canada - Toronto Tel: 905-695-1980 Fax: 905-695-2078</p>	<p>Australia - Sydney Tel: 61-2-9868-6733</p> <p>China - Beijing Tel: 86-10-8569-7000</p> <p>China - Chengdu Tel: 86-28-8665-5511</p> <p>China - Chongqing Tel: 86-23-8980-9588</p> <p>China - Dongguan Tel: 86-769-8702-9880</p> <p>China - Guangzhou Tel: 86-20-8755-8029</p> <p>China - Hangzhou Tel: 86-571-8792-8115</p> <p>China - Hong Kong SAR Tel: 852-2943-5100</p> <p>China - Nanjing Tel: 86-25-8473-2460</p> <p>China - Qingdao Tel: 86-532-8502-7355</p> <p>China - Shanghai Tel: 86-21-3326-8000</p> <p>China - Shenyang Tel: 86-24-2334-2829</p> <p>China - Shenzhen Tel: 86-755-8864-2200</p> <p>China - Suzhou Tel: 86-186-6233-1526</p> <p>China - Wuhan Tel: 86-27-5980-5300</p> <p>China - Xian Tel: 86-29-8833-7252</p> <p>China - Xiamen Tel: 86-592-2388138</p> <p>China - Zhuhai Tel: 86-756-3210040</p>	<p>India - Bangalore Tel: 91-80-3090-4444</p> <p>India - New Delhi Tel: 91-11-4160-8631</p> <p>India - Pune Tel: 91-20-4121-0141</p> <p>Japan - Osaka Tel: 81-6-6152-7160</p> <p>Japan - Tokyo Tel: 81-3-6880-3770</p> <p>Korea - Daegu Tel: 82-53-744-4301</p> <p>Korea - Seoul Tel: 82-2-554-7200</p> <p>Malaysia - Kuala Lumpur Tel: 60-3-7651-7906</p> <p>Malaysia - Penang Tel: 60-4-227-8870</p> <p>Philippines - Manila Tel: 63-2-634-9065</p> <p>Singapore Tel: 65-6334-8870</p> <p>Taiwan - Hsin Chu Tel: 886-3-577-8366</p> <p>Taiwan - Kaohsiung Tel: 886-7-213-7830</p> <p>Taiwan - Taipei Tel: 886-2-2508-8600</p> <p>Thailand - Bangkok Tel: 66-2-694-1351</p> <p>Vietnam - Ho Chi Minh Tel: 84-28-5448-2100</p>	<p>Austria - Wels Tel: 43-7242-2244-39 Fax: 43-7242-2244-393</p> <p>Denmark - Copenhagen Tel: 45-4450-2828 Fax: 45-4485-2829</p> <p>Finland - Espoo Tel: 358-9-4520-820</p> <p>France - Paris Tel: 33-1-69-53-63-20 Fax: 33-1-69-30-90-79</p> <p>Germany - Garching Tel: 49-8931-9700</p> <p>Germany - Haan Tel: 49-2129-3766400</p> <p>Germany - Heilbronn Tel: 49-7131-67-3636</p> <p>Germany - Karlsruhe Tel: 49-721-625370</p> <p>Germany - Munich Tel: 49-89-627-144-0 Fax: 49-89-627-144-44</p> <p>Germany - Rosenheim Tel: 49-8031-354-560</p> <p>Israel - Ra'anana Tel: 972-9-744-7705</p> <p>Italy - Milan Tel: 39-0331-742611 Fax: 39-0331-466781</p> <p>Italy - Padova Tel: 39-049-7625286</p> <p>Netherlands - Drunen Tel: 31-416-690399 Fax: 31-416-690340</p> <p>Norway - Trondheim Tel: 47-72884388</p> <p>Poland - Warsaw Tel: 48-22-3325737</p> <p>Romania - Bucharest Tel: 40-21-407-87-50</p> <p>Spain - Madrid Tel: 34-91-708-08-90 Fax: 34-91-708-08-91</p> <p>Sweden - Gothenberg Tel: 46-31-704-60-40</p> <p>Sweden - Stockholm Tel: 46-8-5090-4654</p> <p>UK - Wokingham Tel: 44-118-921-5800 Fax: 44-118-921-5820</p>

X-ON Electronics

Largest Supplier of Electrical and Electronic Components

Click to view similar products for [Daughter Cards & OEM Boards](#) category:

Click to view products by [Microchip](#) manufacturer:

Other Similar products are found below :

[ADZS-21262-1-EZEXT](#) [27911](#) [SPC56ELADPT144S](#) [TMDXRM46CNCD](#) [DM160216](#) [EV-ADUCM350GPIOHZ](#) [EV-ADUCM350-BIO3Z](#)
[ATSTK521](#) [1130](#) [MA160015](#) [MA180033](#) [MA240013](#) [MA240026](#) [MA320014](#) [MA330014](#) [MA330017](#) [TLK10034SMAEVM](#) [MIKROE-](#)
[2152](#) [MIKROE-2154](#) [MIKROE-2381](#) [TSSOP20EV](#) [DEV-11723](#) [MIKROE-1108](#) [MIKROE-1516](#) [SPS-READER-GEVK](#) [AC244049](#)
[AC244050](#) [AC320004-3](#) [2077](#) [ATSMARTCARD-XPRO](#) [EIC - Q600 -230](#) [ATZB-212B-XPRO](#) [SPC560PADPT100S](#) [SPC560BADPT64S](#)
[MA180018](#) [EIC - Q600 -220](#) [AC164134-1](#) [BOB-12035](#) [STM8/128-D/RAIS](#) [AC164127-6](#) [AC164127-4](#) [AC164134-3](#) [AC164156](#) [MA320021](#)
[MA320024](#) [DFR0285](#) [DFR0312](#) [DFR0356](#) [MA320023](#) [MIKROE-2564](#)