

dsPIC33CH128MP508 Motor Control Plug-In Module (PIM) Information Sheet

The dsPIC33CH128MP508 Motor Control PIM (P/N: MA330039) is designed to demonstrate the capabilities of the dsPIC33CH128MP508 device.

The devices from the dsPIC33CH128MP508 family are the first Microchip dual core, 16-bit Digital Signal Controllers. The dsPIC33CH128MP508 has two Digital Signal Controller (DSC) cores, namely 'Master Core' and 'Slave Core', that can run independently at different device frequencies.

This Motor Control PIM is designed to take advantage of the high-resolution PWM (with fine edge placement) peripheral in the Slave core of the device. The PWM, along with other peripherals such as the ADC, enable motor control applications.

The PIM can be used to demonstrate and develop motor control application, by inserting it in the 100-pin PIM interface header provided on the compatible motor control development boards (see [Table 1](#)). The PIM is designed to run a single motor with all the compatible development boards. When operating this PIM on the dsPICDEM™ MCLV-2 Development Board, insert an external op amp configuration matrix board on the J14 header (see [Figure 2](#)) provided on the board. In the case of the dsPICDEM MCHV-2/MCHV-3 Development Boards, insert an external op amp configuration matrix board on to the J4 header (as shown in [Figure 2](#)) on the board. The PIM is capable of driving a single motor through the Inverter-B side of the Low-Voltage Motor Control Bundle (DV330100).

For additional information regarding development boards, refer to the respective user's guides available on the Microchip web site (www.microchip.com).

FIGURE 1: dsPIC33CH128MP508 MOTOR CONTROL PIM (P/N: MA330039)

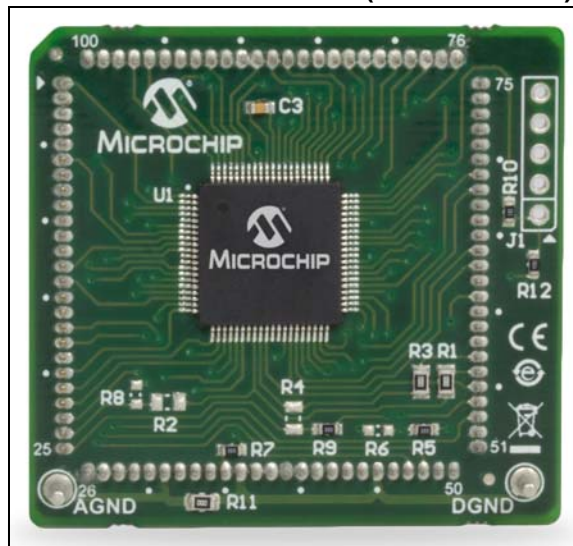

[Table 1](#) provides information on the hardware versions of the motor control boards that are compatible with this PIM. Refer to the user's guide of the specific motor control board to find information related to hardware version identification.

FIGURE 2: EXTERNAL OP AMP CONFIGURATION BOARD



dsPIC33CH128MP508

TABLE 1: HARDWARE COMPATIBILITY

Development Board	Part Number	Compatible Hardware Version(s)
dsPICDEM™ MCHV Development Board	DM330023	Not Compatible
dsPICDEM MCLV Development Board	DM330021	Not Compatible
dsPICDEM MCSM Development Board	DM330022	Not Compatible
dsPICDEM MCHV-2 Development Board	DM330023-2	All Revisions
dsPICDEM MCLV-2 Development Board	DM330021-2	All Revisions
dsPICDEM MCHV-3 Development Board	DM330023-3	All Revisions
Low-Voltage Motor Control Development Bundle	DV330100	All Revisions

dsPIC33CH128MP508

Table 2 provides the mapping between the 80-pin device pinout and the 100-pin PIM.

TABLE 2: DEVICE TO PIM MAPPING (SORTED BY DEVICE PIN NUMBER)

Device Pin #	Master Core Pin Function	Slave Core #1 Pin Function	PIM Pin # if Connected	Remarks
1	RP46/PWM1H/RB14	S1RP46/S1RB14	PIM:47	Direct Connection
2	RE0	S1RE0	PIM:01	Direct Connection
3	RP47/PWM1L/RB15	S1RP47/S1RB15	PIM:48	Direct Connection
4	RE1	S1RE1	PIM:53	Direct Connection
5	RP60/PWM4H/RC12	S1RP60/S1RC12	PIM:61	Direct Connection
6	RP61/PWM4L/RC13	S1RP61/S1RC13	PIM:80	Direct Connection
7	RP62/RC14	S1RP62/S1PWM7H/S1RC14	PIM:07	Direct Connection
8	RP63/RC15	S1RP63/S1PWM7L/S1RC15	PIM:06	Direct Connection
9	MCLR	—	PIM:13	MCLR
10	PCI22/RD15	S1PCI22/S1RD15	PIM:19	Direct Connection
11	Vss		PIM:15, 36, 45, 65, 75 ⁽⁴⁾	Digital Ground (DGND)
12	VDD		PIM:02, 16, 37, 46, 62, 86 ⁽³⁾	Digital Power (DVDD)
13	PCI21/RD14	S1ANN1/S1PGA2N2/S1PCI21/S1RD14	PIM:12	Direct Connection
14	RD13	S1ANN0/S1PGA1N2/S1RD13	PIM:11	Direct Connection
15	AN12/BIAS3/RP48/RC0	S1AN10/S1RP48/S1RC0	PIM:83	Direct Connection
16	AN0/CMP1A/RA0	S1RA0	PIM:97	Direct Connection
17	RE2	S1RE2	PIM:82	Direct Connection
18	AN1/RA1	S1AN15/S1RA1	PIM:14	Direct Connection
19	RE3	S1RE3	PIM:29	Direct Connection
20	AN2/RA2	S1AN16/S1RA2	PIM:20	Direct Connection
21	AN3/BIAS0/RA3	S1AN0/S1CMP1A/S1PGA1P1/S1RA3	PIM:21	Direct Connection
22	RE4	S1RE4	PIM:69	Direct Connection
23	AN4/BIAS1/RA4	S1MCLR3/S1AN1/S1CMP2A/S1PGA2P1/S1PGA3P2/S1RA4	PIM:22	Direct Connection
24	RE5	S1RE5	PIM:68	Direct Connection
25	AVDD		PIM:30	Analog Power (AVDD)
26	AVss		PIM:31 ⁽⁵⁾	Analog Ground (AGND)
27	RD12	S1AN14/S1PGA2P2/S1RD12	PIM:79	Direct Connection
28	AN13/ISRC0/RP49/RC1	S1ANA1/S1RP49/S1RC1	PIM:56 ⁽¹⁾	Connected via 0 Ohm Resistor
			PIM:24 ⁽²⁾	Can be Connected via 0 Ohm Resistor
29	AN14/ISRC1/RP50/RC2	S1ANA0/S1RP50/S1RC2	PIM:57 ⁽¹⁾	Connected via 0 Ohm Resistor
			PIM:25 ⁽²⁾	Can be Connected via 0 Ohm Resistor

- Note 1:** The device pin is directly connected to the PIM pin through a 0 Ohm resistor (default), which can be removed if desired.
- Note 2:** The device pin can be connected directly to the PIM pin through a 0 Ohm resistor, if desired. For proper operation, ensure that other 0 Ohm resistors connecting to the same device pin are removed.
- Note 3:** Digital Power (DVDD) pins are shorted together on the PIM.
- Note 4:** Digital Ground (DGND) pins are shorted together on the PIM.
- Note 5:** Analog Ground (AVss) connection via PIM:31 is shorted with Digital Ground (DGND) through 0 Ohm resistor, R12, on the PIM.
- Note 6:** These pins are dedicated for Slave only program/debug purposes in dual core controllers. Program/debug tool can be connected via the ICSP™ header, J1; not connected to any of the PIM pins.

dsPIC33CH128MP508

TABLE 2: DEVICE TO PIM MAPPING (SORTED BY DEVICE PIN NUMBER) (CONTINUED)

Device Pin #	Master Core Pin Function	Slave Core #1 Pin Function	PIM Pin # if Connected	Remarks
30	RP54/RC6	S1AN11/S1CMP1B/S1RP54/S1RC6	PIM:55	Direct Connection
31	VDD		PIM:02, 16, 37, 46, 62, 86 ⁽³⁾	Digital Power (DVDD)
32	VSS		PIM:15, 36, 45, 65, 75 ⁽⁴⁾	Digital Ground (DGND)
33	CMP1B/RP51/RC3	S1AN8/S1CMP3B/S1RP51/S1RC3	PIM:23	Direct Connection
34	OSCI/CLKI/AN5/RP32/RB0	S1AN5/S1RP32/S1RB0	PIM:63	Direct Connection
35	OSCO/CLKO/AN6/IBIAS2/RP33/RB1	S1AN4/S1RP33/S1RB1	PIM:64	Direct Connection
36	RD11	S1AN17/S1PGA1P2/S1RD11	PIM:32	Direct Connection
37	RE6	S1PGA3N2/S1RE6	PIM:33	Direct Connection
38	ISRC3/RD10	S1AN13/S1CMP2B/S1RD10	PIM:35 ⁽¹⁾	Connected via 0 Ohm Resistor
			PIM:24 ⁽²⁾	Can be Connected via 0 Ohm Resistor
39	RE7	S1RE7	PIM:34	Direct Connection
40	AN15/ISRC2/RP55/RC7	S1AN12/S1RP55/S1RC7	PIM:17	Direct Connection
41	DACOUT/AN7/CMP1D/RP34/INT0/RB2	S1MCLR2/S1AN3/S1ANC0/S1ANC1/S1CMP1D/S1CMP2D/S1CMP3D/S1RP34/S1INT0/S1RB2	PIM:54	Direct Connection
42	RE8	S1RE8	PIM:40	Direct Connection
43	PGD2/AN8/RP35/RB3	S1PGD2/S1AN18/S1CMP3A/S1PGA3P1/S1RP35/S1RB3	PIM:25 ⁽²⁾	Can be Connected via 0 Ohm Resistor
44	RE9	S1RE9	PIM:41	Direct Connection
45	PGC2/RP36/RB4	S1PGC2/S1AN9/S1RP36/S1PWM5L/S1RB4	PIM:78	Direct Connection
46	RP56/ASDA1/SCK2/RC8	S1RP56/S1ASDA1/S1SCK1/S1RC8	PIM:50 ⁽¹⁾	Connected via 0 Ohm Resistor
			PIM:69 ⁽²⁾	Can be Connected via 0 Ohm Resistor
47	RP57/ASCL1/SDI2/RC9	S1RP57/S1ASCL1/S1SDI1/S1RC9	PIM:49	Direct Connection
48	PCI20/RD9	S1PCI20/S1RD9	PIM:10	Direct Connection
49	SDO2/PCI19/RD8	S1SDO1/S1PCI19/S1RD8	PIM:18	Direct Connection
50	VSS		PIM:15, 36, 45, 65, 75 ⁽⁴⁾	Digital Ground (DGND)
51	VDD		PIM:02, 16, 37, 46, 62, 86 ⁽³⁾	Digital Power (DVDD)
52	RP71/RD7	S1RP71/S1PWM8H/S1RD7	PIM:09	Direct Connection
53	RP70/RD6	S1RP70/S1PWM6H/S1RD6	PIM:04	Direct Connection
54	RP69/RD5	S1RP69/S1PWM6L/S1RD5	PIM:05	Direct Connection
55	PGD3/RP37/SDA2/RB5	S1PGD3/S1RP37/S1RB5	PIM:27	PGD

- Note 1:** The device pin is directly connected to the PIM pin through a 0 Ohm resistor (default), which can be removed if desired.
- Note 2:** The device pin can be connected directly to the PIM pin through a 0 Ohm resistor, if desired. For proper operation, ensure that other 0 Ohm resistors connecting to the same device pin are removed.
- Note 3:** Digital Power (DVDD) pins are shorted together on the PIM.
- Note 4:** Digital Ground (DGND) pins are shorted together on the PIM.
- Note 5:** Analog Ground (AVSS) connection via PIM:31 is shorted with Digital Ground (DGND) through 0 Ohm resistor, R12, on the PIM.
- Note 6:** These pins are dedicated for Slave only program/debug purposes in dual core controllers. Program/debug tool can be connected via the ICSP™ header, J1; not connected to any of the PIM pins.

dsPIC33CH128MP508

TABLE 2: DEVICE TO PIM MAPPING (SORTED BY DEVICE PIN NUMBER) (CONTINUED)

Device Pin #	Master Core Pin Function	Slave Core #1 Pin Function	PIM Pin # if Connected	Remarks
56	PGC3/RP38/SCL2/RB6	S1PGC3/S1RP38/S1RB6	PIM:26	PGC
57	RE10	S1RE10	PIM:59	Direct Connection
58	TDO/AN9/RP39/RB7	S1MCLR1/S1AN6/S1RP39/ S1PWM5H/S1RB7	— ⁽⁶⁾	Connected via 100 Ohm to J1:5 (Slave MCLR)
59	RE11	S1RE11	PIM:60	Direct Connection
60	PGD1/AN10/RP40/SCL1/RB8	S1PGD1/S1AN7/S1RP40/ S1SCL1/S1RB8	— ⁽⁶⁾	Direct Connection J1:4 (Slave PGD)
61	PGC1/AN11/RP41/SDA1/RB9	S1PGC1/S1RP41/S1SDA1/ S1RB9	— ⁽⁶⁾	Direct Connection J1:5 (Slave PGC)
62	ASCL2/RE12	S1RE12	PIM:87	Direct Connection
63	RP52/RC4	S1RP52/S1PWM2H/S1RC4	PIM:99	Direct Connection
64	ASDA2/RE13	S1RE13	PIM:88	Direct Connection
65	RP53/RC5	S1RP53/S1PWM2L/S1RC5	PIM:98	Direct Connection
66	RP58/RC10	S1RP58/S1PWM1H/S1RC10	PIM:94	Direct Connection
67	RP59/RC11	S1RP59/S1PWM1L/S1RC11	PIM:93	Direct Connection
68	RP68/RD4	S1RP68/S1PWM3H/S1RD4	PIM:03	Direct Connection
69	RP67/RD3	S1RP67/S1PWM3L/S1RD3	PIM:100	Direct Connection
70	Vss		PIM:15, 36, 45, 65, 75 ⁽⁴⁾	Digital Ground (DGND)
71	VDD		PIM:02, 16, 37, 46, 62, 86 ⁽³⁾	Digital Power (DVDD)
72	RP66/RD2	S1RP66/S1PWM8L/S1RD2	PIM:08	Direct Connection
73	RP65/RD1	S1RP65/S1PWM4H/S1RD1	PIM:76	Direct Connection
74	RP64/RD0	S1RP64/S1PWM4L/S1RD0	PIM:43	Direct Connection
75	TMS/RP42/PWM3H/RB10	S1RP42/S1RB10	PIM:89	Direct Connection
76	TCK/RP43/PWM3L/RB11	S1RP43/S1RB11	PIM:92	Direct Connection
77	RE14	S1RE14	PIM:84	Direct Connection
78	TDI/RP44/PWM2H/RB12	S1RP44/S1RB12	PIM:95	Direct Connection
79	RE15	S1RE15	PIM:90	Direct Connection
80	RP45/PWM2L/RB13	S1RP45/S1RB13	PIM:96	Direct Connection

- Note 1:** The device pin is directly connected to the PIM pin through a 0 Ohm resistor (default), which can be removed if desired.
- Note 2:** The device pin can be connected directly to the PIM pin through a 0 Ohm resistor, if desired. For proper operation, ensure that other 0 Ohm resistors connecting to the same device pin are removed.
- Note 3:** Digital Power (DVDD) pins are shorted together on the PIM.
- Note 4:** Digital Ground (DGND) pins are shorted together on the PIM.
- Note 5:** Analog Ground (AVss) connection via PIM:31 is shorted with Digital Ground (DGND) through 0 Ohm resistor, R12, on the PIM.
- Note 6:** These pins are dedicated for Slave only program/debug purposes in dual core controllers. Program/debug tool can be connected via the ICSP™ header, J1; not connected to any of the PIM pins.

dsPIC33CH128MP508

Table 3 provides the static mapping between the device pins and the 100-pin PIM pins.

TABLE 3: DEVICE TO PIM MAPPING (SORTED BY PIM PIN NUMBER)

PIM Pin #	Device Pin #	Master Core Pin Function	Slave Core #1 Pin Function	Remarks
PIM:01	2	RE0	S1RE0	Direct Connection to Device Pin
PIM:02 ⁽³⁾	12, 31, 51, 71	VDD		Digital Power (DVDD)
PIM:03	68	RP68/RD4	S1RP68/S1PWM3H/S1RD4	Direct Connection to Device Pin
PIM:04	53	RP70/RD6	S1RP70/S1PWM6H/S1RD6	Direct Connection to Device Pin
PIM:05	54	RP69/RD5	S1RP69/S1PWM6L/S1RD5	Direct Connection to Device Pin
PIM:06	8	RP63/RC15	S1RP63/S1PWM7L/S1RC15	Direct Connection to Device Pin
PIM:07	7	RP62/RC14	S1RP62/S1PWM7H/S1RC14	Direct Connection to Device Pin
PIM:08	72	RP66/RD2	S1RP66/S1PWM8L/S1RD2	Direct Connection to Device Pin
PIM:09	52	RP71/RD7	S1RP71/S1PWM8H/S1RD7	Direct Connection to Device Pin
PIM:10	48	PCI20/RD9	S1PCI20/S1RD9	Direct Connection to Device Pin
PIM:11	14	RD13	S1ANN0/S1PGA1N2/S1RD13	Direct Connection to Device Pin
PIM:12	13	PCI21/RD14	S1ANN1/S1PGA2N2/S1PCI21/S1RD14	Direct Connection to Device Pin
PIM:13	9	MCLR	—	MCLR
PIM:14	18	AN1/RA1	S1AN15/S1RA1	Direct Connection to Device Pin
PIM:15 ⁽⁴⁾	11, 32, 50, 70	VSS		Digital Ground (DGND)
PIM:16 ⁽³⁾	12, 31, 51, 71	VDD		Digital Power (DVDD)
PIM:17	40	AN15/ISRC2/RP55/RC7	S1AN12/S1RP55/S1RC7	Direct Connection to Device Pin
PIM:18	49	SDO2/PCI19/CRED6/RD8	S1SDO1/S1PCI19/S1RD8	Direct Connection to Device Pin
PIM:19	10	PCI22/RD15	S1PCI22/S1RD15	Direct Connection to Device Pin
PIM:20	20	AN2/RA2	S1AN16/S1RA2	Direct Connection to Device Pin
PIM:21	21	AN4/IBIAS0/RA3	S1AN0/S1CMP1A/S1PGA1P1/S1RA3	Direct Connection to Device Pin
PIM:22	23	AN4/IBIAS1/RA4	S1MCLR3/S1AN1/S1CMP2A/S1PGA2P1/S1PGA3P2/S1RA4	Direct Connection to Device Pin
PIM:23	33	CMP1B/RP51/RC3	S1AN8/S1CMP3B/S1RP51/S1RC3	Direct Connection to Device Pin
PIM:24 ⁽²⁾	28	AN13/ISRC0/RP49/RC1	S1ANA1/S1RP49/S1RC1	Can be Connected via 0 Ohm Resistor
	38	ISRC3/RD10	S1AN13/S1CMP2B/S1RD10	Can be Connected via 0 Ohm Resistor
PIM:25 ⁽²⁾	43	PGD2/AN8/RP35/RB3	S1PGD2/S1AN18/S1CMP3A/S1RP35/S1PGA3P1/S1RB3	Can be Connected via 0 Ohm Resistor
	29	AN14/ISRC1/RP50/RC2	S1ANA0/S1RP50/S1RC2	Can be Connected via 0 Ohm Resistor
PIM:26	56	PGC3/RP38/SCL2/RB6	S1PGC3/S1RP38/S1RB6	Direct Connection to Device Pin
PIM:27	55	PGD3/RP37/SDA2/RB5	S1PGD3/S1RP37/S1RB5	Direct Connection to Device Pin
PIM:28	—	—	—	Not Connected
PIM:29	19	RE3	S1RE3	Direct Connection to Device Pin

- Note 1:** The PIM pin is directly connected to the device pin through a 0 Ohm resistor (default), which can be removed if desired.
- 2:** The PIM pin can be connected to a device pin through a 0 Ohm resistor, if required. For proper operation, ensure that other 0 Ohm resistors connecting to the same device pin are removed.
- 3:** Digital Power (DVDD) pins are shorted together on the PIM.
- 4:** Digital Ground (DGND) pins are shorted together on the PIM.
- 5:** Analog Ground (AVSS) connection via PIM:31 is shorted with Digital Ground (DGND) through 0 Ohm resistor, R12, on the PIM.

dsPIC33CH128MP508

TABLE 3: DEVICE TO PIM MAPPING (SORTED BY PIM PIN NUMBER) (CONTINUED)

PIM Pin #	Device Pin #	Master Core Pin Function	Slave Core #1 Pin Function	Remarks
PIM:30	25	AVDD		Analog Power (AVDD)
PIM:31 ⁽⁵⁾	26	AVSS		Analog Ground (AGND)
PIM:32	36	RD11	S1AN17/S1PGA1P2/S1RD11	Direct Connection to Device Pin
PIM:33	37	RE6	S1PGA3N2/S1RE6	Direct Connection to Device Pin
PIM:34	39	RE7	S1RE7	Direct Connection to Device Pin
PIM:35 ⁽¹⁾	38	ISRC3/RD10	S1AN13/S1CMP2B/S1RD10	Connected via 0 Ohm Resistor
PIM:36 ⁽⁴⁾	11, 32, 50, 70	Vss		Digital Ground (DGND)
PIM:37 ⁽³⁾	12, 31, 51, 71	VDD		Digital Power (DVDD)
PIM:38	—	—	—	Not Connected
PIM:39	—	—	—	Not Connected
PIM:40	42	RE8	S1RE8	Direct Connection to Device Pin
PIM:41	44	RE9	S1RE9	Direct Connection to Device Pin
PIM:42	—	—	—	Not Connected
PIM:43	74	RP64/RD0	S1RP64/S1PWM4L/S1RD0	Direct Connection to Device Pin
PIM:44	—	—	—	Not Connected
PIM:45 ⁽⁴⁾	11, 32, 50, 70	Vss		Digital Ground (DGND)
PIM:46 ⁽³⁾	12, 31, 51, 71	VDD		Digital Power (DVDD)
PIM:47	1	RP46/PWM1H/RB14	S1RP46/S1RB14	Direct Connection to Device Pin
PIM:48	3	RP47/PWM1L/RB15	S1RP47/S1RB15	Direct Connection to Device Pin
PIM:49	47	RP57/ASCL1/SDI2/RC9	S1RP57/S1ASCL1/S1RC0	Direct Connection to Device Pin
PIM:50 ⁽¹⁾	46	RP56/ASDA1/SCK2/RC8	S1RP56/S1ASDA1/S1RC8	Connected via 0 Ohm Resistor
PIM:51	—	—	—	Not Connected
PIM:52	—	—	—	Not Connected
PIM:53	4	RE1	S1RE1	Direct Connection to Device Pin
PIM:54	41	AMP1OUT/AN7/CMP1D/ SACOUT1/RP34/INT0/RB2	S1MCLR2/S1AN3/S1ANC0/ S1ANC1/S1CMP1D/S1CMP2D/ S1CMP3D/S1RP34/ S1INT0/S1RB2	Direct Connection to Device Pin
PIM:55	30	RP54/RC6	S1AN11/S1CMP1B/S1RP54/ S1RC6	Direct Connection to Device Pin
PIM:56 ⁽¹⁾	28	AN13/ISRC0/RP49/RC1	S1ANA1/S1RP49/S1RC1	Connected via 0 Ohm Resistor
PIM:57 ⁽¹⁾	29	AN14/ISRC1/RP50/RC2	S1ANA0/S1RP50/S1RC2	Connected via 0 Ohm Resistor
PIM:58	—	—	—	Not Connected
PIM:59	57	RE10	S1RE10	Direct Connection to Device Pin
PIM:60	59	RE11	S1RE11	Direct Connection to Device Pin
PIM:61	5	RP60/PWM4H/RC12	S1RP60/S1RC12	Direct Connection to Device Pin
PIM:62 ⁽³⁾	12, 31, 51, 71	VDD		Digital Power (DVDD)
PIM:63	34	OSCI/CLKI/AN5/RP32/RB0	S1AN5/S1RP32/S1RB0	Direct Connection to Device Pin

Note 1: The PIM pin is directly connected to the device pin through a 0 Ohm resistor (default), which can be removed if desired.

Note 2: The PIM pin can be connected to a device pin through a 0 Ohm resistor, if required. For proper operation, ensure that other 0 Ohm resistors connecting to the same device pin are removed.

Note 3: Digital Power (DVDD) pins are shorted together on the PIM.

Note 4: Digital Ground (DGND) pins are shorted together on the PIM.

Note 5: Analog Ground (AVSS) connection via PIM:31 is shorted with Digital Ground (DGND) through 0 Ohm resistor, R12, on the PIM.

dsPIC33CH128MP508

TABLE 3: DEVICE TO PIM MAPPING (SORTED BY PIM PIN NUMBER) (CONTINUED)

PIM Pin #	Device Pin #	Master Core Pin Function	Slave Core #1 Pin Function	Remarks
PIM:64	35	OSCO/CLKO/AN6/IBIAS2/RP33/RB1	S1AN4/S1RP33/S1RB1	Direct Connection to Device Pin
PIM:65 ⁽⁴⁾	11, 32, 50, 70	Vss		Digital Ground (DGND)
PIM:66	—	—	—	Not Connected
PIM:67	—	—	—	Not Connected
PIM:68	24	RE5	S1RE5	Direct Connection to Device Pin
PIM:69	22	RE4	S1RE4	Direct Connection to Device Pin
PIM:69 ⁽²⁾	46	RP56/ASDA1/SCK2/RC8	S1RP56/S1ASDA1/S1RC8	Can be Connected via 0 Ohm Resistor
PIM:70	—	—	—	Not Connected
PIM:71	—	—	—	Not Connected
PIM:72	—	—	—	Not Connected
PIM:73	—	—	—	Not Connected
PIM:74	—	—	—	Not Connected
PIM:75 ⁽⁴⁾	11, 32, 50, 70	Vss		Digital Ground (DGND)
PIM:76	73	RP65/RD1	S1RP65/S1PWM4H/S1RD1	Direct Connection to Device Pin
PIM:77	—	—	—	Not Connected
PIM:78	45	PGC2/RP36/RB4	S1PGC2/S1AN9/S1RP36/S1PWM5L/S1RB4	Direct Connection to Device Pin
PIM:79	27	RD12	S1AN14/S1PGA2P2/S1RD12	Direct Connection to Device Pin
PIM:80	6	RP61/PWM4L/RC13	S1RP61/S1RC13	Direct Connection to Device Pin
PIM:81	—	—	—	Not Connected
PIM:82	17	RE2	S1RE2	Direct Connection to Device Pin
PIM:83	15	AN12/IBIAS3/RP48/RC0	S1AN10/S1RP48/S1RC0	Direct Connection to Device Pin
PIM:84	77	RE14	S1RE14	Direct Connection to Device Pin
PIM:85	—	—	—	Not Connected
PIM:86 ⁽³⁾	12, 31, 51, 71	VDD		Digital Power (DVDD)
PIM:87	62	ASCL2/RE12	S1RE12	Direct Connection to Device Pin
PIM:88	64	ASDA2/RE13	S1RE13	Direct Connection to Device Pin
PIM:89	75	TMS/RP42/PWM3H/RB10	S1RP42/S1RB10	Direct Connection to Device Pin
PIM:90	79	RE15	S1RE15	Direct Connection to Device Pin
PIM:91	—	—	—	Not Connected
PIM:92	76	TCK/RP43/PWM3L/RB11	S1RP43/S1RB11	Direct Connection to Device Pin
PIM:93	67	RP59/RC11	S1RP59/S1PWM1L/S1RC11	Direct Connection to Device Pin
PIM:94	66	RP58/RC10	S1RP58/S1PWM1H/S1RC10	Direct Connection to Device Pin
PIM:95	78	TDI/RP44/PWM2H/RB12	S1RP44/S1RB12	Direct Connection to Device Pin
PIM:96	80	RP45/PWM2L/RB13	S1RP45/S1RB13	Direct Connection to Device Pin
PIM:97	16	AN0/CMP1A/RA0	S1RA0	Direct Connection to Device Pin
PIM:98	65	RP53/RC5	S1RP53/S1PWM2L/S1RC5	Direct Connection to Device Pin
PIM:99	63	RP52/RC4	S1RP52/S1PWM2H/S1RC4	Direct Connection to Device Pin
PIM:100	69	RP67/RD3	S1RP67/S1PWM3L/S1RD3	Direct Connection to Device Pin

- Note 1:** The PIM pin is directly connected to the device pin through a 0 Ohm resistor (default), which can be removed if desired.
- Note 2:** The PIM pin can be connected to a device pin through a 0 Ohm resistor, if required. For proper operation, ensure that other 0 Ohm resistors connecting to the same device pin are removed.
- Note 3:** Digital Power (DVDD) pins are shorted together on the PIM.
- Note 4:** Digital Ground (DGND) pins are shorted together on the PIM.
- Note 5:** Analog Ground (AVss) connection via PIM:31 is shorted with Digital Ground (DGND) through 0 Ohm resistor, R12, on the PIM.

Slave ICSP™ Interface Header J1 for Slave Debug in “Dual Debug” Mode

The Master and Slave cores of the dsPIC33CH128MP508(U1) device can be debugged simultaneously (Dual Debug mode).

In Dual Debug mode:

- Two debugger tools must be interfaced with the device for Master and Slave debug
- The device pins, $\overline{MCLR}/PGCx/PGDx$ ($x = 1, 2$ or 3), are used for the Master debug
- The device pins, $\overline{S1MCLR}x/\overline{S1PGC}x/\overline{S1PGD}x$ ($x = 1, 2$ or 3), are used for the Slave debug

The J1 header is provided to interface an additional debugger tool required for Slave debug in Dual Debug mode.

The J1 header connects to the device pins, $\overline{S1MCLR}1$, $\overline{S1PGD}1$ and $\overline{S1PGC}1$ (refer to “[Schematic Revision 1.0](#)”), and is only intended for use during dual debug operations.

For single core debug of either the Master or Slave, use the programmer/debugger interface provided on the development board (where the PIM is plugged in).

When using Dual Debug mode, populate a 5-pin through-hole with a 0.100" (2.54 mm) pitch header (e.g., use header P/N: TSW-105-07-S-S or similar).

For additional information on various program/debug modes of the device and to know how to configure and use these modes in MPLAB® X IDE during development and testing, refer to Microchip application note “AN2721: *Getting Started with Dual Core*” (DS00002721).

WARNING

Do not connect a non-isolated programmer/debugger to the Slave ICSP Interface Header J1 (on the PIM) while using the PIM with the dsPICDEM™ MCHV-2 or MCHV-3 Development Board.

Do not connect non-isolated oscilloscope probes to the test points on the PIM while using the PIM with the dsPICDEM MCHV-2 or MCHV-3 Development Board.

Failure to heed these warnings could result in hardware damage.

dsPIC33CH128MP508 Motor Control Plug-In Module (PIM)

Schematic Revision 1.0

dsPIC33CH128MP508 External Op Amp Motor Control PIM

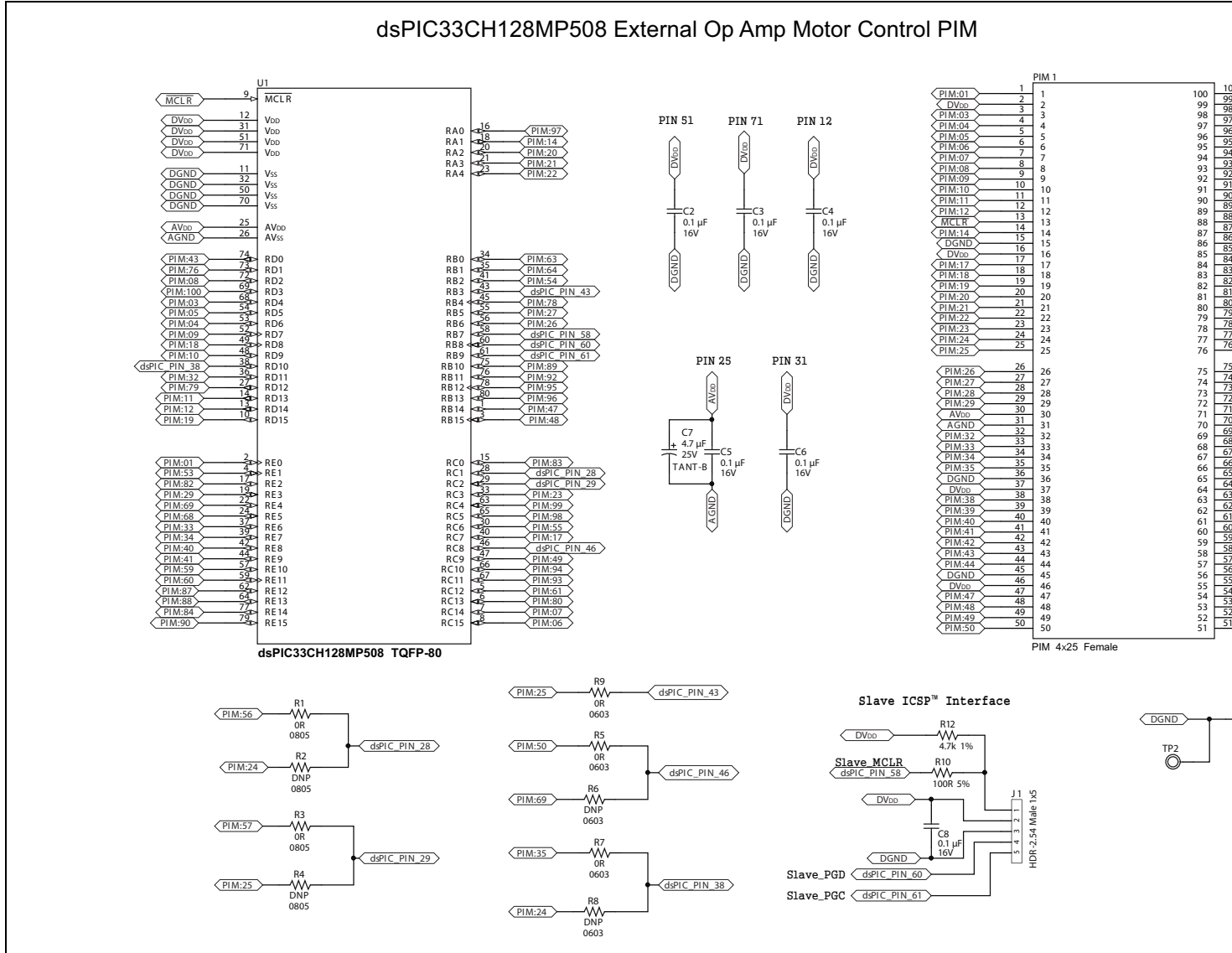

Note the following details of the code protection feature on Microchip devices:

- Microchip products meet the specification contained in their particular Microchip Data Sheet.
- Microchip believes that its family of products is one of the most secure families of its kind on the market today, when used in the intended manner and under normal conditions.
- There are dishonest and possibly illegal methods used to breach the code protection feature. All of these methods, to our knowledge, require using the Microchip products in a manner outside the operating specifications contained in Microchip's Data Sheets. Most likely, the person doing so is engaged in theft of intellectual property.
- Microchip is willing to work with the customer who is concerned about the integrity of their code.
- Neither Microchip nor any other semiconductor manufacturer can guarantee the security of their code. Code protection does not mean that we are guaranteeing the product as “unbreakable.”

Code protection is constantly evolving. We at Microchip are committed to continuously improving the code protection features of our products. Attempts to break Microchip's code protection feature may be a violation of the Digital Millennium Copyright Act. If such acts allow unauthorized access to your software or other copyrighted work, you may have a right to sue for relief under that Act.

Information contained in this publication regarding device applications and the like is provided only for your convenience and may be superseded by updates. It is your responsibility to ensure that your application meets with your specifications. MICROCHIP MAKES NO REPRESENTATIONS OR WARRANTIES OF ANY KIND WHETHER EXPRESS OR IMPLIED, WRITTEN OR ORAL, STATUTORY OR OTHERWISE, RELATED TO THE INFORMATION, INCLUDING BUT NOT LIMITED TO ITS CONDITION, QUALITY, PERFORMANCE, MERCHANTABILITY OR FITNESS FOR PURPOSE. Microchip disclaims all liability arising from this information and its use. Use of Microchip devices in life support and/or safety applications is entirely at the buyer's risk, and the buyer agrees to defend, indemnify and hold harmless Microchip from any and all damages, claims, suits, or expenses resulting from such use. No licenses are conveyed, implicitly or otherwise, under any Microchip intellectual property rights unless otherwise stated.

Microchip received ISO/TS-16949:2009 certification for its worldwide headquarters, design and wafer fabrication facilities in Chandler and Tempe, Arizona; Gresham, Oregon and design centers in California and India. The Company's quality system processes and procedures are for its PIC® MCUs and dsPIC® DSCs, KEELoc® code hopping devices, Serial EEPROMs, microperipherals, nonvolatile memory and analog products. In addition, Microchip's quality system for the design and manufacture of development systems is ISO 9001:2000 certified.

**QUALITY MANAGEMENT SYSTEM
CERTIFIED BY DNV
= ISO/TS 16949 =**

Trademarks

The Microchip name and logo, the Microchip logo, AnyRate, AVR, AVR logo, AVR Freaks, BitCloud, chipKIT, chipKIT logo, CryptoMemory, CryptoRF, dsPIC, FlashFlex, flexPWR, Heldo, JukeBlox, KeeLoq, Klear, LANCheck, LINK MD, maXStylus, maXTouch, MediaLB, megaAVR, MOST, MOST logo, MPLAB, OptoLyzer, PIC, picoPower, PICSTART, PIC32 logo, Prochip Designer, QTouch, SAM-BA, SpyNIC, SST, SST Logo, SuperFlash, tinyAVR, UNI/O, and XMEGA are registered trademarks of Microchip Technology Incorporated in the U.S.A. and other countries.

ClockWorks, The Embedded Control Solutions Company, EtherSynch, Hyper Speed Control, HyperLight Load, IntellIMOS, mTouch, Precision Edge, and Quiet-Wire are registered trademarks of Microchip Technology Incorporated in the U.S.A.

Adjacent Key Suppression, AKS, Analog-for-the-Digital Age, Any Capacitor, AnyIn, AnyOut, BodyCom, CodeGuard, CryptoAuthentication, CryptoAutomotive, CryptoCompanion, CryptoController, dsPICDEM, dsPICDEM.net, Dynamic Average Matching, DAM, ECAN, EtherGREEN, In-Circuit Serial Programming, ICSP, INICnet, Inter-Chip Connectivity, JitterBlocker, KlearNet, KlearNet logo, memBrain, Mindi, MiWi, motorBench, MPASM, MPF, MPLAB Certified logo, MPLIB, MPLINK, MultiTRAK, NetDetach, Omniscient Code Generation, PICDEM, PICDEM.net, PICKit, PICtail, PowerSmart, PureSilicon, QMatrix, REAL ICE, Ripple Blocker, SAM-ICE, Serial Quad I/O, SMART-I.S., SQI, SuperSwitcher, SuperSwitcher II, Total Endurance, TSHARC, USBCheck, VariSense, ViewSpan, WiperLock, Wireless DNA, and ZENA are trademarks of Microchip Technology Incorporated in the U.S.A. and other countries.

SQTP is a service mark of Microchip Technology Incorporated in the U.S.A.

Silicon Storage Technology is a registered trademark of Microchip Technology Inc. in other countries.

GestIC is a registered trademark of Microchip Technology Germany II GmbH & Co. KG, a subsidiary of Microchip Technology Inc., in other countries.

All other trademarks mentioned herein are property of their respective companies.

© 2018, Microchip Technology Incorporated, All Rights Reserved.
ISBN: 978-1-5224-3231-9



MICROCHIP

Worldwide Sales and Service

AMERICAS

Corporate Office
2355 West Chandler Blvd.
Chandler, AZ 85224-6199
Tel: 480-792-7200
Fax: 480-792-7277
Technical Support:
<http://www.microchip.com/support>
Web Address:
www.microchip.com

Atlanta
Duluth, GA
Tel: 678-957-9614
Fax: 678-957-1455

Austin, TX
Tel: 512-257-3370

Boston
Westborough, MA
Tel: 774-760-0087
Fax: 774-760-0088

Chicago
Itasca, IL
Tel: 630-285-0071
Fax: 630-285-0075

Dallas
Addison, TX
Tel: 972-818-7423
Fax: 972-818-2924

Detroit
Novi, MI
Tel: 248-848-4000

Houston, TX
Tel: 281-894-5983

Indianapolis
Noblesville, IN
Tel: 317-773-8323
Fax: 317-773-5453
Tel: 317-536-2380

Los Angeles
Mission Viejo, CA
Tel: 949-462-9523
Fax: 949-462-9608
Tel: 951-273-7800

Raleigh, NC
Tel: 919-844-7510

New York, NY
Tel: 631-435-6000

San Jose, CA
Tel: 408-735-9110
Tel: 408-436-4270

Canada - Toronto
Tel: 905-695-1980
Fax: 905-695-2078

ASIA/PACIFIC

Australia - Sydney
Tel: 61-2-9868-6733

China - Beijing
Tel: 86-10-8569-7000

China - Chengdu
Tel: 86-28-8665-5511

China - Chongqing
Tel: 86-23-8980-9588

China - Dongguan
Tel: 86-769-8702-9880

China - Guangzhou
Tel: 86-20-8755-8029

China - Hangzhou
Tel: 86-571-8792-8115

China - Hong Kong SAR
Tel: 852-2943-5100

China - Nanjing
Tel: 86-25-8473-2460

China - Qingdao
Tel: 86-532-8502-7355

China - Shanghai
Tel: 86-21-3326-8000

China - Shenyang
Tel: 86-24-2334-2829

China - Shenzhen
Tel: 86-755-8864-2200

China - Suzhou
Tel: 86-186-6233-1526

China - Wuhan
Tel: 86-27-5980-5300

China - Xian
Tel: 86-29-8833-7252

China - Xiamen
Tel: 86-592-2388138

China - Zhuhai
Tel: 86-756-3210040

ASIA/PACIFIC

India - Bangalore
Tel: 91-80-3090-4444

India - New Delhi
Tel: 91-11-4160-8631

India - Pune
Tel: 91-20-4121-0141

Japan - Osaka
Tel: 81-6-6152-7160

Japan - Tokyo
Tel: 81-3-6880-3770

Korea - Daegu
Tel: 82-53-744-4301

Korea - Seoul
Tel: 82-2-554-7200

Malaysia - Kuala Lumpur
Tel: 60-3-7651-7906

Malaysia - Penang
Tel: 60-4-227-8870

Philippines - Manila
Tel: 63-2-634-9065

Singapore
Tel: 65-6334-8870

Taiwan - Hsin Chu
Tel: 886-3-577-8366

Taiwan - Kaohsiung
Tel: 886-7-213-7830

Taiwan - Taipei
Tel: 886-2-2508-8600

Thailand - Bangkok
Tel: 66-2-694-1351

Vietnam - Ho Chi Minh
Tel: 84-28-5448-2100

EUROPE

Austria - Wels
Tel: 43-7242-2244-39
Fax: 43-7242-2244-393

Denmark - Copenhagen
Tel: 45-4450-2828
Fax: 45-4485-2829

Finland - Espoo
Tel: 358-9-4520-820

France - Paris
Tel: 33-1-69-53-63-20
Fax: 33-1-69-30-90-79

Germany - Garching
Tel: 49-8931-9700

Germany - Haan
Tel: 49-2129-3766400

Germany - Heilbronn
Tel: 49-7131-67-3636

Germany - Karlsruhe
Tel: 49-721-625370

Germany - Munich
Tel: 49-89-627-144-0
Fax: 49-89-627-144-44

Germany - Rosenheim
Tel: 49-8031-354-560

Israel - Ra'anana
Tel: 972-9-744-7705

Italy - Milan
Tel: 39-0331-742611
Fax: 39-0331-466781

Italy - Padova
Tel: 39-049-7625286

Netherlands - Drunen
Tel: 31-416-690399
Fax: 31-416-690340

Norway - Trondheim
Tel: 47-7289-7561

Poland - Warsaw
Tel: 48-22-3325737

Romania - Bucharest
Tel: 40-21-407-87-50

Spain - Madrid
Tel: 34-91-708-08-90
Fax: 34-91-708-08-91

Sweden - Gothenberg
Tel: 46-31-704-60-40

Sweden - Stockholm
Tel: 46-8-5090-4654

UK - Wokingham
Tel: 44-118-921-5800
Fax: 44-118-921-5820

X-ON Electronics

Largest Supplier of Electrical and Electronic Components

Click to view similar products for [Daughter Cards & OEM Boards](#) category:

Click to view products by [Microchip](#) manufacturer:

Other Similar products are found below :

[ADZS-21262-1-EZEXT](#) [27911](#) [SPC56ELADPT144S](#) [TMDXRM46CNCD](#) [DM160216](#) [EV-ADUCM350GPIOHZ](#) [EV-ADUCM350-BIO3Z](#)
[ATSTK521](#) [1130](#) [MA160015](#) [MA180033](#) [MA240013](#) [MA240026](#) [MA320014](#) [MA330014](#) [MA330017](#) [TLK10034SMAEVM](#) [MIKROE-](#)
[2152](#) [MIKROE-2154](#) [MIKROE-2381](#) [TSSOP20EV](#) [DEV-11723](#) [MIKROE-1108](#) [MIKROE-1516](#) [SPS-READER-GEVK](#) [AC244049](#)
[AC244050](#) [AC320004-3](#) [2077](#) [ATSMARTCARD-XPRO](#) [EIC - Q600 -230](#) [ATZB-212B-XPRO](#) [SPC560PADPT100S](#) [SPC560BADPT64S](#)
[MA180018](#) [EIC - Q600 -220](#) [AC164134-1](#) [BOB-12035](#) [STM8/128-D/RAIS](#) [AC164127-6](#) [AC164127-4](#) [AC164134-3](#) [AC164156](#) [MA320021](#)
[MA320024](#) [DFR0285](#) [DFR0312](#) [DFR0356](#) [MA320023](#) [MIKROE-2564](#)