

Three-Channel Analog Front-End Device with 1 mV_{PP} Input Detection Sensitivity

Device Features

- Three input pins for analog input signals
- High input detection sensitivity (1 mV_{PP}, typical)
- High modulation depth sensitivity (as low as 8%)
- Three output selections:
 - Demodulated data
 - Carrier clock
 - RSSI
- Input carrier frequency: 125 kHz, typical
- Input data rate: 10 Kbps, maximum
- Eight internal configuration registers
- Bidirectional transponder communication (LF talk back)
- Programmable antenna tuning capacitance (up to 63 pF, 1 pF/step)
- Programmable output-enable filter
- Low standby current: 6.5 μA (with three channels enabled), typical
- Low operating current: 19 μA (with three channels enabled), typical
- Serial Peripheral Interface (SPI) with external devices
- Supports Battery Backup mode and batteryless operation with external circuits
- Industrial and Extended Temperature Range: -40°C to +85°C (industrial)

Typical Applications

- Automotive industry applications:
 - Passive Keyless Entry (PKE) transponder
 - Remote door locks and gate openers
 - Engine immobilizer
 - LF initiator sensor for tire pressure monitoring systems
- Security Industry applications:
 - Long range access control transponder
 - Parking lot entry transponder
 - Hands-free apartment door access
 - Asset control and management

Description

The MCP2030A is a stand-alone Analog Front-End (AFE) device for Low-Frequency (LF) sensing and bidirectional communication applications. The device has eight internal configuration registers. These registers, with the exception of the read-only Status register, are readable and programmable by an external device.

The device has three low-frequency input channels. Each input channel can be individually enabled or disabled. The device can detect an input signal with amplitude as low as ~1 mV_{PP} and can demodulate an amplitude-modulated input signal with as low as 8% modulation depth. The device can also transmit data by clamping and unclamping the input LC antenna voltage.

The device can output demodulated data, carrier clock, or RSSI current, depending on the register setting. The demodulated data and carrier clock outputs are available on the LFDATA pin, while the RSSI output is available on the RSSI pin. The RSSI current output is linearly proportional to the input signal strength.

The device has programmable internal tuning capacitors for each input channel. The user can program these capacitors up to 63 pF, 1 pF per step. These internal tuning capacitors can be used effectively for fine-tuning of the external LC resonant circuit.

The device is optimized for very low current consumption and has various battery-saving low-power modes (Sleep, Standby, Active). The device can also be operated in Battery Backup and Batteryless modes using a few external components.

This device is available in 14-pin PDIP, SOIC, and TSSOP packages.

Package Types

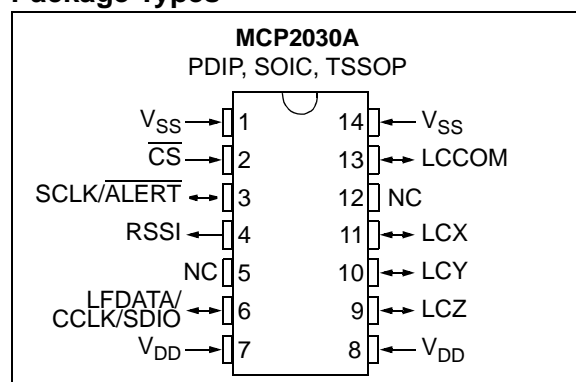

MCP2030A

NOTES:

1.0 ELECTRICAL SPECIFICATIONS

Absolute Maximum Ratings^(†)

Ambient temperature under bias.....	-40°C to +125°C
Storage temperature	-65°C to +150°C
Voltage on V _{DD} with respect to V _{SS}	-0.3V to +6.5V
Voltage on all other pins with respect to V _{SS}	-0.3V to (V _{DD} + 0.3V)
Maximum current out of V _{SS} pin	300 mA
Maximum current into V _{DD} pin	250 mA
Maximum LC Input Voltage (LCX, LCY, LCZ) loaded, with device.....	10.0 V _{PP}
Maximum LC Input Voltage (LCX, LCY, LCZ) unloaded, without device.....	700.0 V _{PP}
Maximum Input Current (rms) into device per LC Channel.....	10 mA
Human Body ESD rating.....	2000 (min.) V
Machine Model ESD rating	200 (min.) V

† **Notice:** Stresses above those listed under “Maximum Ratings” may cause permanent damage to the device. This is a stress rating only and functional operation of the device at those or any other conditions above those indicated in the operation listings of this specification is not implied. Exposure to maximum rating conditions for extended periods may affect device reliability.

DC ELECTRICAL CHARACTERISTICS

Electrical Specifications:		Standard Operating Conditions (unless otherwise stated)				
Operating temperature		-40°C ≤ T _A ≤ +85°C				
LC Signal Input		Sinusoidal 300 mV _{PP}				
Carrier Frequency		125 kHz				
LCCOM connected to V _{SS}						
Parameters	Sym	Min	Typ ⁽²⁾	Max	Units	Conditions
Supply Voltage	V _{DD}	2.0	3.0	3.6	V	
V _{DD} Start Voltage to ensure internal Power-on Reset (POR) signal	V _{POR}	—	—	1.8	V	
Modulation Transistor-on Resistance	R _M	—	50	100	W	V _{DD} = 3.0V
Active Current (detecting signal)	I _{ACT}					$\overline{CS} = V_{DD}$
1 LC Input Channel Receiving Signal		—	10	—	μA	Input = Continuous Wave (CW); Amplitude = 300 mV _{PP} All channels enabled.
3 LC Input Channel Receiving Signals		—	19	25	μA	
Standby Current (wait to detect signal)	I _{STDBY}					$\overline{CS} = V_{DD}; \overline{ALERT} = V_{DD}$
1 LC Input Channel Enabled		—	2	5	μA	
2 LC Input Channels Enabled		—	5	8	μA	
3 LC Input Channels Enabled		—	6.5	10.5	μA	
Sleep Current	I _{SLEEP}	—	0.2	1	μA	$\overline{CS} = V_{DD}; \overline{ALERT} = V_{DD}$
Analog Input Leakage Current	I _{AIL}					V _{DD} = 3.6V, V _{SS} ≤ V _{IN} ≤ 1V with respect to ground. Internal tuning capacitors are switched off, tested in Sleep mode.
LCX, LCY, LCZ		—	—	±1	μA	
LCCOM		—	—	±1	μA	
Digital Input Low Voltage	V _{IL}	V _{SS}	—	0.3 V _{DD}	V	SCLK, SDI, \overline{CS}
Digital Input High Voltage	V _{IH}	0.8 V _{DD}	—	V _{DD}	V	SCLK, SDI, \overline{CS}
Digital Input Leakage Current ⁽³⁾	I _{IL}					V _{DD} = 3.6V
SDI		—	—	±1	μA	V _{SS} ≤ V _{PIN} ≤ V _{DD} V _{PIN} ≤ V _{DD}
SCLK, \overline{CS}		—	—	±1	μA	

Note 1: These parameters are characterized but not tested.

Note 2: Data in “Typ” column is at 3.0V, +25°C unless otherwise stated. These parameters are for design guidance only and are not tested.

Note 3: Negative current is defined as current sourced by the pin.

MCP2030A

DC ELECTRICAL CHARACTERISTICS (CONTINUED)

Electrical Specifications:		Standard Operating Conditions (unless otherwise stated)				
Operating temperature		$-40^{\circ}\text{C} \leq T_A \leq +85^{\circ}\text{C}$				
LC Signal Input		Sinusoidal 300 mV _{PP}				
Carrier Frequency		125 kHz				
LCCOM connected to V _{SS}						
Parameters	Sym	Min	Typ ⁽²⁾	Max	Units	Conditions
Digital Output Low Voltage ALERT, LFDATA/SDIO	V _{OL}	—	—	V _{SS} + 0.4	V	Analog Front-End section I _{OL} = 1.0 mA, V _{DD} = 2.0V
Digital Output High Voltage ALERT, LFDATA/SDIO	V _{OH}	V _{DD} - 0.5	—	—	V	I _{OH} = -400 μA, V _{DD} = 2.0V
Digital Input Pull-Up Resistor CS, SCLK	R _{PU}	50	200	350	kΩ	V _{DD} = 3.6V

- Note 1:** These parameters are characterized but not tested.
- Note 2:** Data in "Typ" column is at 3.0V, +25°C unless otherwise stated. These parameters are for design guidance only and are not tested.
- Note 3:** Negative current is defined as current sourced by the pin.

AC ELECTRICAL CHARACTERISTICS

Electrical Specifications:		Standard Operating Conditions (unless otherwise stated)				
Operating temperature		-40°C ≤ T _A ≤ +85°C				
LC Signal Input		Sinusoidal 300 mV _{PP}				
Carrier Frequency		125 kHz				
LCCOM connected to V _{SS}						
Parameters	Sym	Min	Typ ⁽²⁾	Max	Units	Conditions
Input Sensitivity	V _{SENSE}	—	1	—	mV _{PP}	V _{DD} = 3.0V Output-enable filter disabled, AGCSIG = 0; MODMIN = 00 (33% modulation depth setting) Input = Continuous Wave (CW) Output = Logic level transition from low-to-high at sensitivity level for CW input. Trimmed to 1 mV _{PP} input sensitivity for all channels.
Coil de-Q-ing Voltage - RF Limiter (R _{FLM}) must be active	V _{DE_Q}	3	—	5	V	V _{DD} = 3.0V, Force I _{IN} = 5 μA (worst-case)
RF Limiter Turn-on Resistance (LCX, LCY, LCZ)	R _{FLM}	—	300	700	W	V _{DD} = 2.0V, V _{IN} = 8 VDC
Sensitivity Reduction	S _{ADJ}	— —	0 -30	— —	dB dB	V _{DD} = 3.0V No sensitivity reduction selected Max reduction selected Monotonic increment in attenua- tion value from setting = 0000 to 1111 by design
Minimum Modulation Depth	V _{IN_MOD}	—	60	84	%	V _{DD} = 3.0V See Section 5.21 “Minimum Modulation Depth Require- ment for Input Signal” . See Modulation Depth Definition in Figure 5-5 .
60% setting		—	60	84	%	
33% setting		—	33	49	%	
14% setting		—	14	26	%	
8% setting		—	8	—	%	
Carrier frequency	F _{CARRIER}	—	125	—	kHz	
Input modulation frequency	F _{MOD}	—	—	10	kHz	Input data rate with NRZ data for- mat. V _{DD} = 3.0V Minimum modulation depth set- ting= 33% Input conditions: Amplitude = 300 mV _{PP} Modulation depth = 100%

- Note**
- 1: Parameter is characterized but not tested.
 - 2: Data in “Typ” column is at 3.0V, +25°C unless otherwise stated. These parameters are for design guidance only and are not tested.
 - 3: Required output-enable filter high time must account for input path analog delays (= T_{OEH} - T_{DR} + T_{DF}).
 - 4: Required output-enable filter low time must account for input path analog delays (= T_{OEL} + T_{DR} - T_{DF}).

MCP2030A

AC ELECTRICAL CHARACTERISTICS (CONTINUED)

Electrical Specifications:		Standard Operating Conditions (unless otherwise stated)				
Operating temperature		-40°C ≤ T _A ≤ +85°C				
LC Signal Input		Sinusoidal 300 mV _{PP}				
Carrier Frequency		125 kHz				
LCCOM connected to V _{SS}						
Parameters	Sym	Min	Typ ⁽²⁾	Max	Units	Conditions
LCX Tuning Capacitor	C _{TUNX}	— 44	0 59	— 82	pF pF	V _{DD} = 3.0V, Config. Reg. 1, bits <6:1> Setting = 000000 63 pF ±30% Config. Reg. 1, bits <6:1> Setting = 111111 63 steps, approx. 1 pF/step Monotonic increment in capacitor value from setting = 000000 to 111111 by design
LCY Tuning Capacitor	C _{TUNY}	— 44	0 59	— 82	pF pF	V _{DD} = 3.0V, Config. Reg. 2, bits <6:1> Setting = 000000 63 pF ±30% Config. Reg. 2, bits <6:1> Setting = 111111 63 steps, approx. 1 pF/step Monotonic increment in capacitor value from setting = 000000 to 111111 by design
LCZ Tuning Capacitor	C _{TUNZ}	— 44	0 59	— 82	pF pF	V _{DD} = 3.0V, Config. Reg. 3, bits<6:1> Setting = 000000 63 pF ±30% Config. Reg. 3, bits<6:1> Setting = 111111 63 steps, approx. 1 pF/step Monotonic increment in capacitor value from setting = 000000 to 111111 by design
Q of Internal Tuning Capacitors	Q_C	50 ⁽¹⁾	—	—		
Demodulator Charge Time (delay time of demodulated output to rise)	T _{DR}	—	50	—	μs	V _{DD} = 3.0V Minimum modulation depth setting = 33% Input conditions: Amplitude = 300 mV _{PP} Modulation depth = 100%
Demodulator Discharge Time (delay time of demodulated output to fall)	T _{DF}	—	50	—	μs	V _{DD} = 3.0V MOD depth setting = 33% Input conditions: Amplitude = 300 mV _{PP} Modulation depth = 100%
Rise time of LFDATA	TR _{LFDATA}	—	0.5	—	μs	V _{DD} = 3.0V. Time is measured from 10% to 90% of amplitude

Note 1: Parameter is characterized but not tested.

Note 2: Data in "Typ" column is at 3.0V, +25°C unless otherwise stated. These parameters are for design guidance only and are not tested.

Note 3: Required output-enable filter high time must account for input path analog delays (= T_{OEH} - T_{DR} + T_{DF}).

Note 4: Required output-enable filter low time must account for input path analog delays (= T_{OEL} + T_{DR} - T_{DF}).

AC ELECTRICAL CHARACTERISTICS (CONTINUED)

Electrical Specifications: Standard Operating Conditions (unless otherwise stated)						
Operating temperature		-40°C ≤ T _A ≤ +85°C				
LC Signal Input		Sinusoidal 300 mV _{PP}				
Carrier Frequency		125 kHz				
LCCOM connected to V _{SS}						
Parameters	Sym	Min	Typ ⁽²⁾	Max	Units	Conditions
Fall time of LFDATA	T _{FLFDATA}	—	0.5	—	μs	V _{DD} = 3.0V Time is measured from 10% to 90% of amplitude
AGC stabilization time (T _{AGC} + T _{PAGC})	T _{STAB}	4	—	—	ms	
AGC initialization time	T _{AGC}	—	3.5	—	ms	
High time after AGC initialization time	T _{PAGC}	—	62.5	—	μs	
Gap time after AGC stabilization time	T _{GAP}	200	—	—	μs	
Time element of pulse	T _E	100	—	—	μs	Minimum pulse width
Time from exiting Sleep or POR to being ready to receive signal	T _{RDY}	—	—	50 ⁽¹⁾	ms	
Minimum time AGC level must be held after receiving AGC Preserve command	T _{PRES}	5 ⁽¹⁾	—	—	ms	AGC level must not change more than 10% during T _{PRES}
Internal RC oscillator frequency	F _{OSC}	27	32	35.5	kHz	Internal clock trimmed at 32 kHz during test
Inactivity timer time-out	T _{INACT}	13.5	16	17.75	ms	512 cycles of RC oscillator @ F _{OSC}
Alarm timer time-out	T _{ALARM}	27	32	35.5	ms	1024 cycles of RC oscillator @ F _{OSC}
LC Pin Input Resistance for LCX, LCY, LCZ pins	R _{IN}	—	800 ⁽¹⁾	—	kΩ	LCCOM grounded, V _{DD} = 3V, F _{CARRIER} = 125 kHz
LC Pin Input Parasitic Capacitance for LCX, LCY, LCZ pins	C _{IN}	—	24 ⁽¹⁾	—	pF	LCCOM grounded, V _{DD} = 3V, F _{CARRIER} = 125 kHz
Minimum output-enable filter high time OEH (Bits Config0<8:7>) 01 = 1 ms 10 = 2 ms 11 = 4 ms 00 = Filter Disabled	T _{OEH}	32 (~1 ms) 64 (~2 ms) 128 (~4 ms) —	— — — —	— — — —	clock count	RC oscillator = F _{OSC} (see F _{OSC} specification for variations). Viewed from the pin input ⁽³⁾
Minimum output-enable filter low time OEL (Bits Config0<6:5>) 00 = 1 ms 01 = 1 ms 10 = 2 ms 11 = 4 ms	T _{OEL}	32 (~1 ms) 32 (~1 ms) 64 (~2 ms) 128 (~4 ms)	— — — —	— — — —	clock count	RC oscillator = F _{OSC} Viewed from the pin input ⁽⁴⁾

Note 1: Parameter is characterized but not tested.

Note 2: Data in "Typ" column is at 3.0V, +25°C unless otherwise stated. These parameters are for design guidance only and are not tested.

Note 3: Required output-enable filter high time must account for input path analog delays (= T_{OEH} - T_{DR} + T_{DF}).

Note 4: Required output-enable filter low time must account for input path analog delays (= T_{OEL} + T_{DR} - T_{DF}).

MCP2030A

AC ELECTRICAL CHARACTERISTICS (CONTINUED)

Parameters		Sym	Min	Typ ⁽²⁾	Max	Units	Conditions
Electrical Specifications:		Standard Operating Conditions (unless otherwise stated)					
Operating temperature		-40°C ≤ T _A ≤ +85°C					
LC Signal Input		Sinusoidal 300 mV _{PP}					
Carrier Frequency		125 kHz					
LCCOM connected to V _{SS}							
Maximum output-enable filter period		T _{OET}					RC oscillator = F _{OSC}
OE_H	OEL	T_{OE_H}	T_{OE_L}				
01	00	= 1 ms	1 ms (Filter 1)	—	—	96 (~3 ms)	
01	01	= 1 ms	1 ms (Filter 1)	—	—	96 (~3 ms)	
01	10	= 1 ms	1 ms (Filter 2)	—	—	128 (~4 ms)	
01	11	= 1 ms	1 ms (Filter 3)	—	—	192 (~6 ms)	
10	00	= 2 ms	1 ms (Filter 4)	—	—	128 (~4 ms)	
10	01	= 2 ms	1 ms (Filter 4)	—	—	128 (~4 ms)	
10	10	= 2 ms	2 ms (Filter 5)	—	—	160 (~5 ms)	clock count
10	11	= 2 ms	4 ms (Filter 6)	—	—	250 (~8 ms)	
11	00	= 4 ms	1 ms (Filter 7)	—	—	192 (~6 ms)	
11	01	= 4 ms	1 ms (Filter 7)	—	—	192 (~6 ms)	
11	10	= 4 ms	2 ms (Filter 8)	—	—	256 (~8 ms)	
11	11	= 4 ms	4 ms (Filter 9)	—	—	320 (~10 ms)	
00	XX	=	Filter Disabled	—	—	—	LFDATA output appears as long as input signal level is greater than V _{SENSE} .
RSSI current output		I _{RSSI}	—	3	—	μA	V _{IN} = 30 mV _{PP}
			—	30	—	μA	V _{IN} = 300 mV _{PP}
			—	250	—	μA	V _{IN} = 3 V _{PP} , V _{DD} = 3.0V, Linearly increases with input signal amplitude.
RSSI current linearity		ILR _{RSSI}	-15	—	15	%	Tested at room temperature only (see Equation 5-1 and Figure 5-7 for test method).

Note 1: Parameter is characterized but not tested.

Note 2: Data in "Typ" column is at 3.0V, +25°C unless otherwise stated. These parameters are for design guidance only and are not tested.

Note 3: Required output-enable filter high time must account for input path analog delays (= T_{OE_H} - T_{DR} + T_{DF}).

Note 4: Required output-enable filter low time must account for input path analog delays (= T_{OE_L} + T_{DR} - T_{DF}).

SPI TIMING

Electrical Specifications:		Standard Operating Conditions (unless otherwise stated)				
Operating temperature		-40°C ≤ T _A ≤ +85°C				
LC Signal Input		Sinusoidal 300 mV _{PP}				
Carrier Frequency		125 kHz				
LCCOM connected to V _{SS}						
Parameters	Sym	Min	Typ ⁽¹⁾	Max	Units	Conditions
SCLK Frequency	F _{SCLK}	—	—	3	MHz	
$\overline{\text{CS}}$ fall to first SCLK edge setup time	T _{CSSC}	100	—	—	ns	
SDI setup time	T _{SU}	30	—	—	ns	
SDI hold time	T _{HD}	50	—	—	ns	
SCLK high time	T _{HI}	150	—	—	ns	
SCLK low time	T _{LO}	150	—	—	ns	
SDO setup time	T _{DO}	—	—	150	ns	
SCLK last edge to $\overline{\text{CS}}$ rise setup time	T _{SCCS}	100	—	—	ns	
$\overline{\text{CS}}$ high time	T _{CSH}	500	—	—	ns	
$\overline{\text{CS}}$ rise to SCLK edge setup time	T _{CS1}	50	—	—	ns	
SCLK edge to $\overline{\text{CS}}$ fall setup time	T _{CS0}	50	—	—	ns	SCLK edge when $\overline{\text{CS}}$ is high
Rise time of SPI data (SPI Read command)	T _{RSPI}	—	10	—	ns	V _{DD} = 3.0V. Time is measured from 10% to 90% of amplitude
Fall time of SPI data (SPI Read command)	T _{FSPI}	—	10	—	ns	V _{DD} = 3.0V. Time is measured from 90% to 10% of amplitude
Note 1: Data in "Typ" column is at 3.0V, +25°C unless otherwise stated. These parameters are for design guidance only and are not tested.						

MCP2030A

NOTES:

2.0 TYPICAL PERFORMANCE CURVES

Note: The graphs and tables provided following this note are a statistical summary based on a limited number of samples and are provided for informational purposes only. The performance characteristics listed herein are not tested or guaranteed. In some graphs or tables, the data presented may be outside the specified operating range (e.g., outside specified power supply range) and therefore outside the warranted range.

Note: Unless otherwise indicated, $T_A = -40^{\circ}\text{C}$ to $+85^{\circ}\text{C}$, $V_{DD} = 2.0\text{V} \leq V_{DD} \leq 3.6\text{V}$, $V_{SS} = 0\text{V}$.

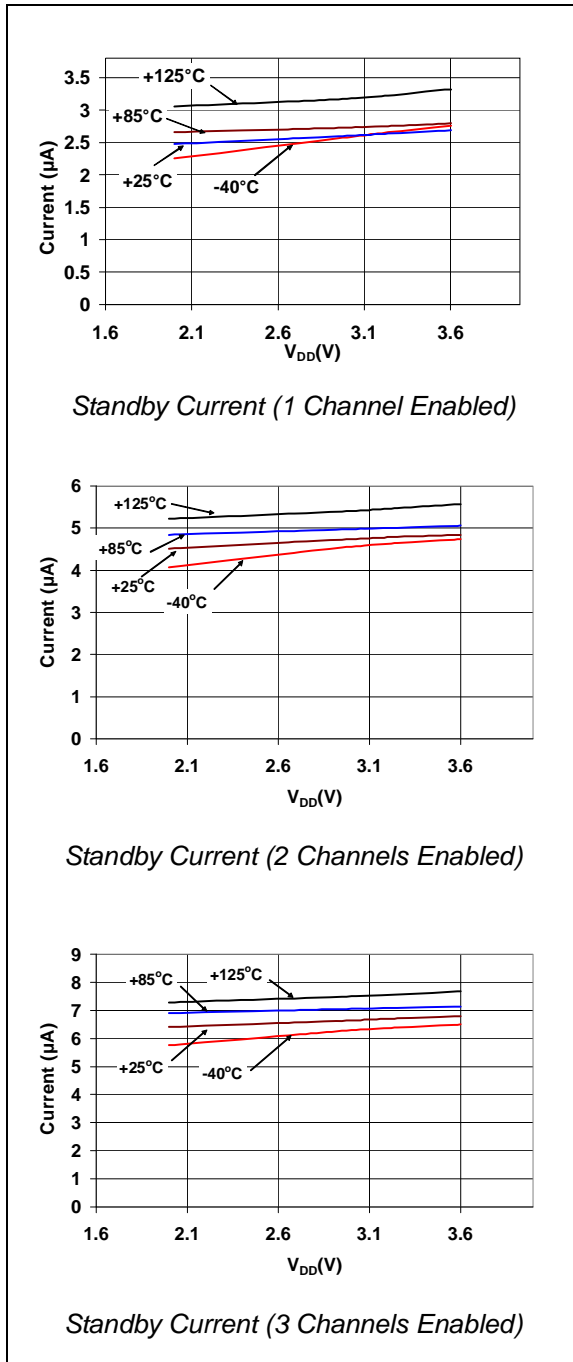

FIGURE 2-1: Typical Standby Current.

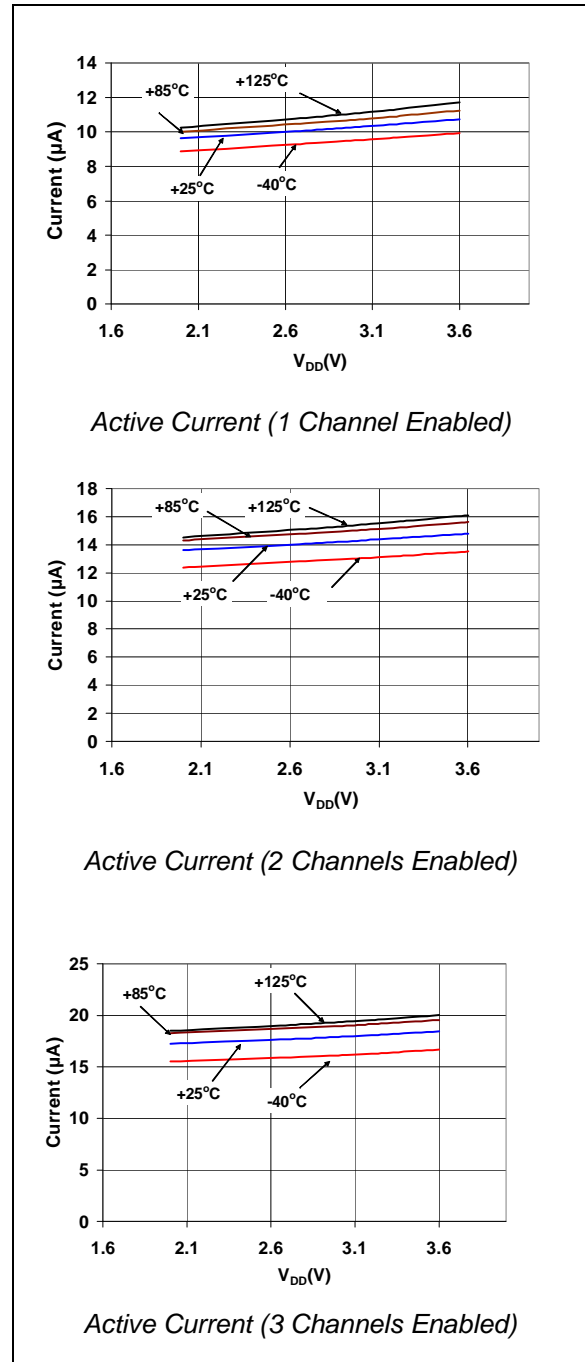

FIGURE 2-2: Typical Active Current.

MCP2030A

Note: Unless otherwise indicated, $T_A = -40^{\circ}\text{C}$ to $+85^{\circ}\text{C}$, $V_{DD} = 2.0\text{V} \leq V_{DD} \leq 3.6\text{V}$, $V_{SS} = 0\text{V}$.

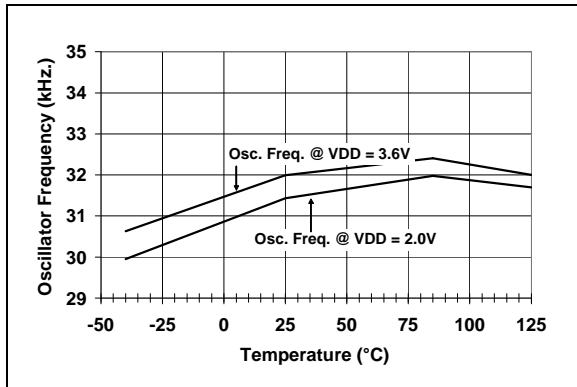

FIGURE 2-3: Oscillator Frequency vs. Temperature, $V_{DD} = 3.6\text{V}$ and 2.0V .

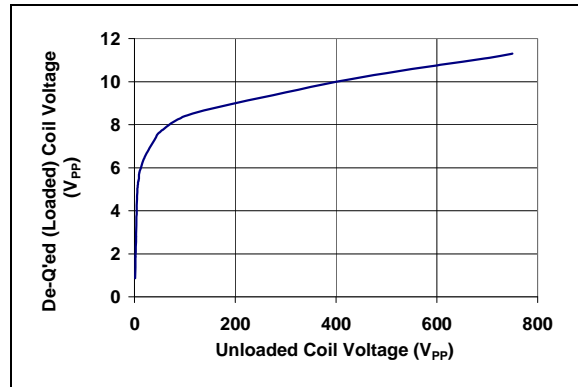

FIGURE 2-6: De-Q'ed Voltage vs. Unloaded Coil Voltage.

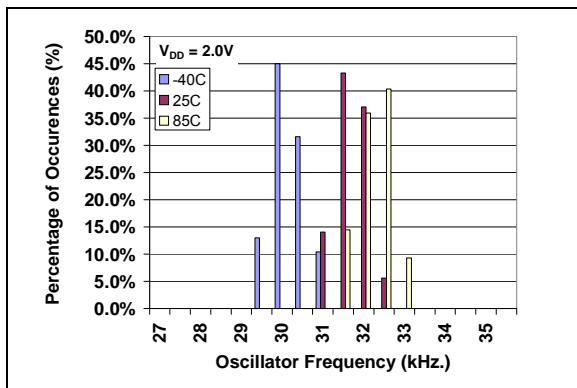

FIGURE 2-4: Oscillator Frequency Histograms vs. Temperature, $V_{DD} = 2\text{V}$.

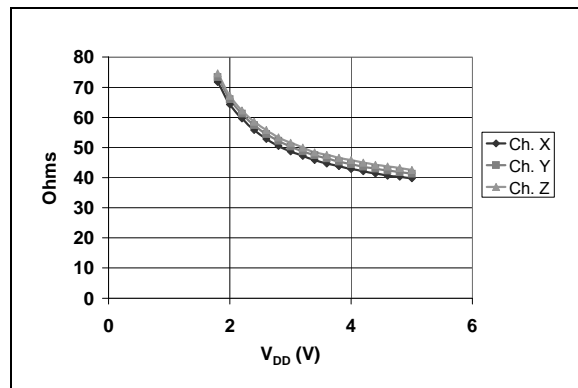

FIGURE 2-7: Modulation Transistor-on Resistance ($+25^{\circ}\text{C}$).

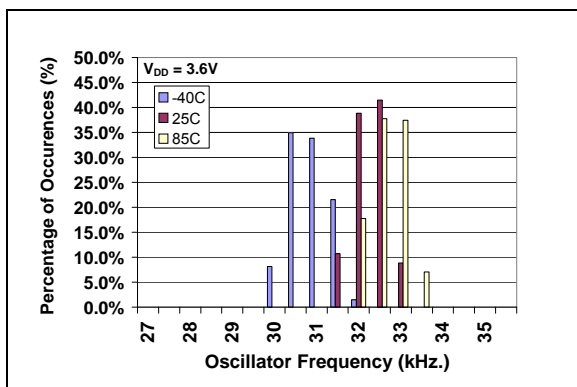

FIGURE 2-5: Oscillator Frequency Histograms vs. Temperature at $V_{DD} = 3\text{V}$.

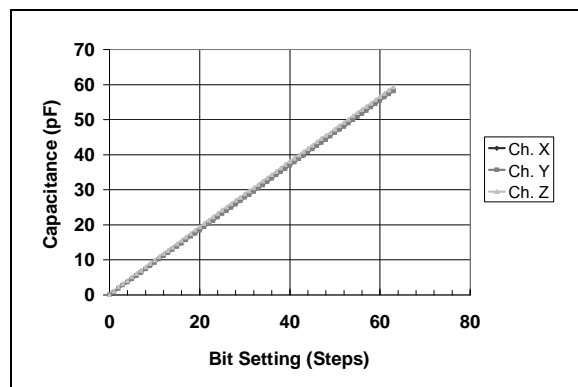

FIGURE 2-8: Typical Tuned Capacitance Value vs. Configuration Register Bit Setting ($V_{DD} = 3\text{V}$, Temperature = $+25^{\circ}\text{C}$).

Note: Unless otherwise indicated, $T_A = -40^{\circ}\text{C}$ to $+85^{\circ}\text{C}$, $V_{DD} = 2.0\text{V} \leq V_{DD} \leq 3.6\text{V}$, $V_{SS} = 0\text{V}$.

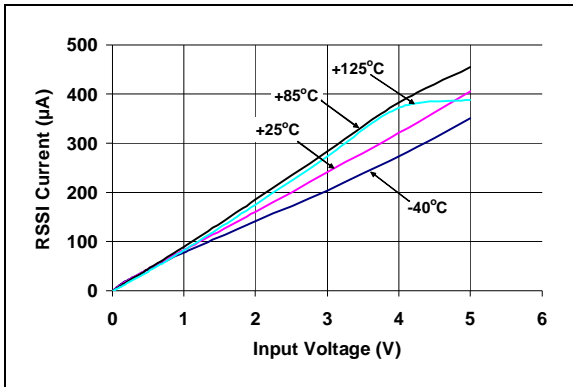

FIGURE 2-9: Typical RSSI Output Current vs. Input Signal Strength.

Note: There are slight variations between channels.

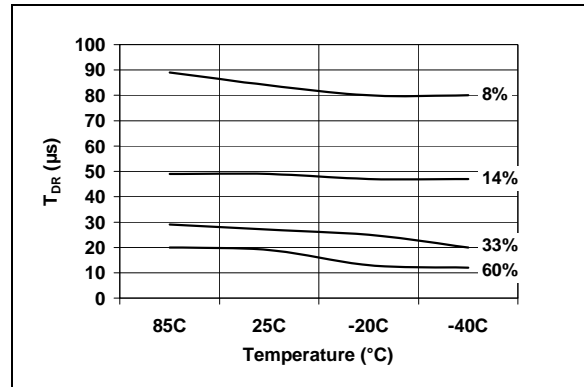

FIGURE 2-12: Example of Typical T_{DR} Changes over Temperature. Input Signal Condition: Amplitude = 300 mVpp, Modulation Depth = 100%.

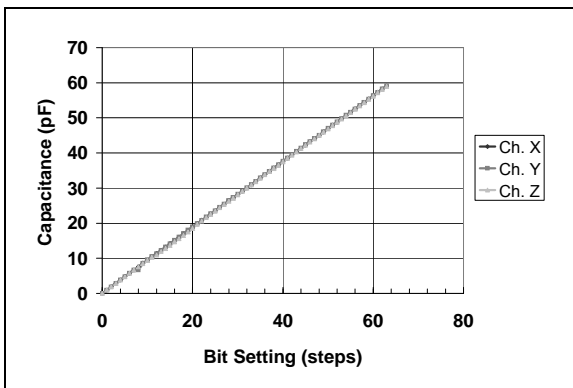

FIGURE 2-10: Typical Tuned Capacitance Value vs. Configuration Register Bit Setting ($V_{DD} = 3\text{V}$, Temperature = -40°C).

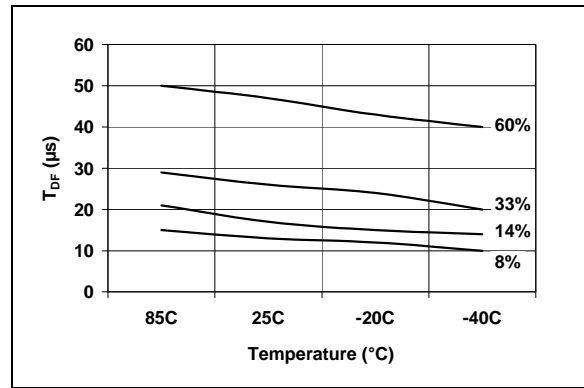

FIGURE 2-13: Example of Typical T_{DF} Changes over Temperature. Input Signal Condition: Amplitude = 300 mVpp, Modulation Depth = 100%.

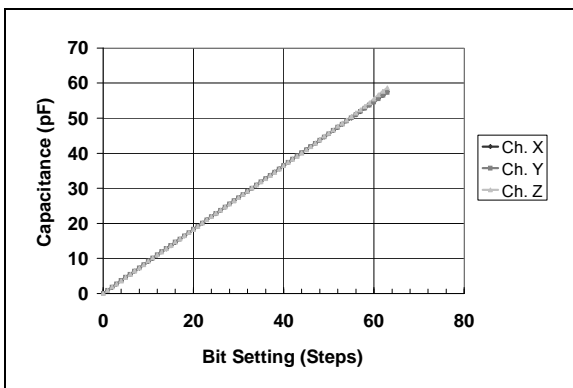

FIGURE 2-11: Typical Tuned Capacitance Value vs. Configuration Register Bit Setting ($V_{DD} = 3\text{V}$, Temperature = $+85^{\circ}\text{C}$).

MCP2030A

2.1 Performance Plots

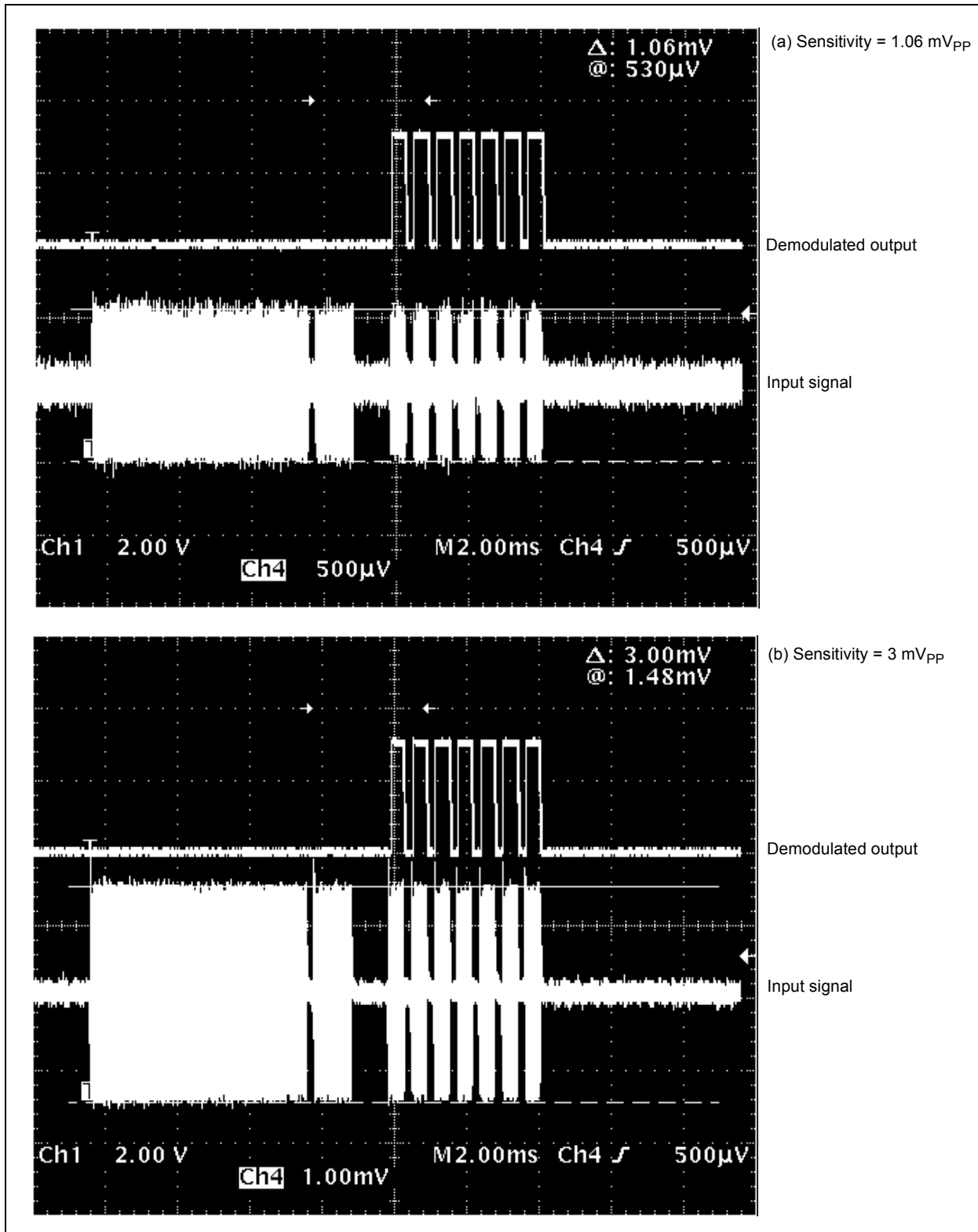

FIGURE 2-14: Input Sensitivity Example.

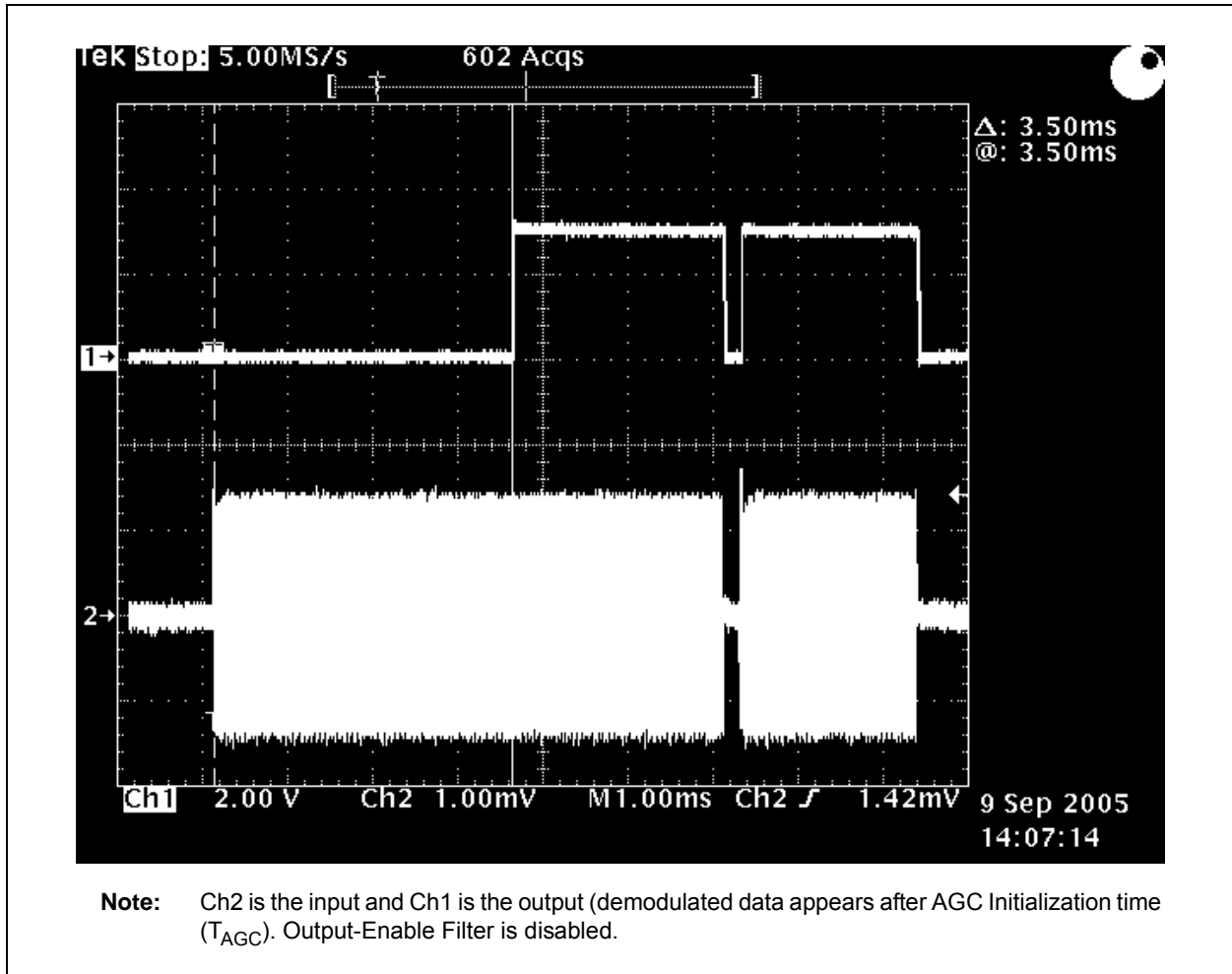

FIGURE 2-15: Typical AGC Initialization Time at Room Temperature ($V_{DD} = 3V$).

MCP2030A

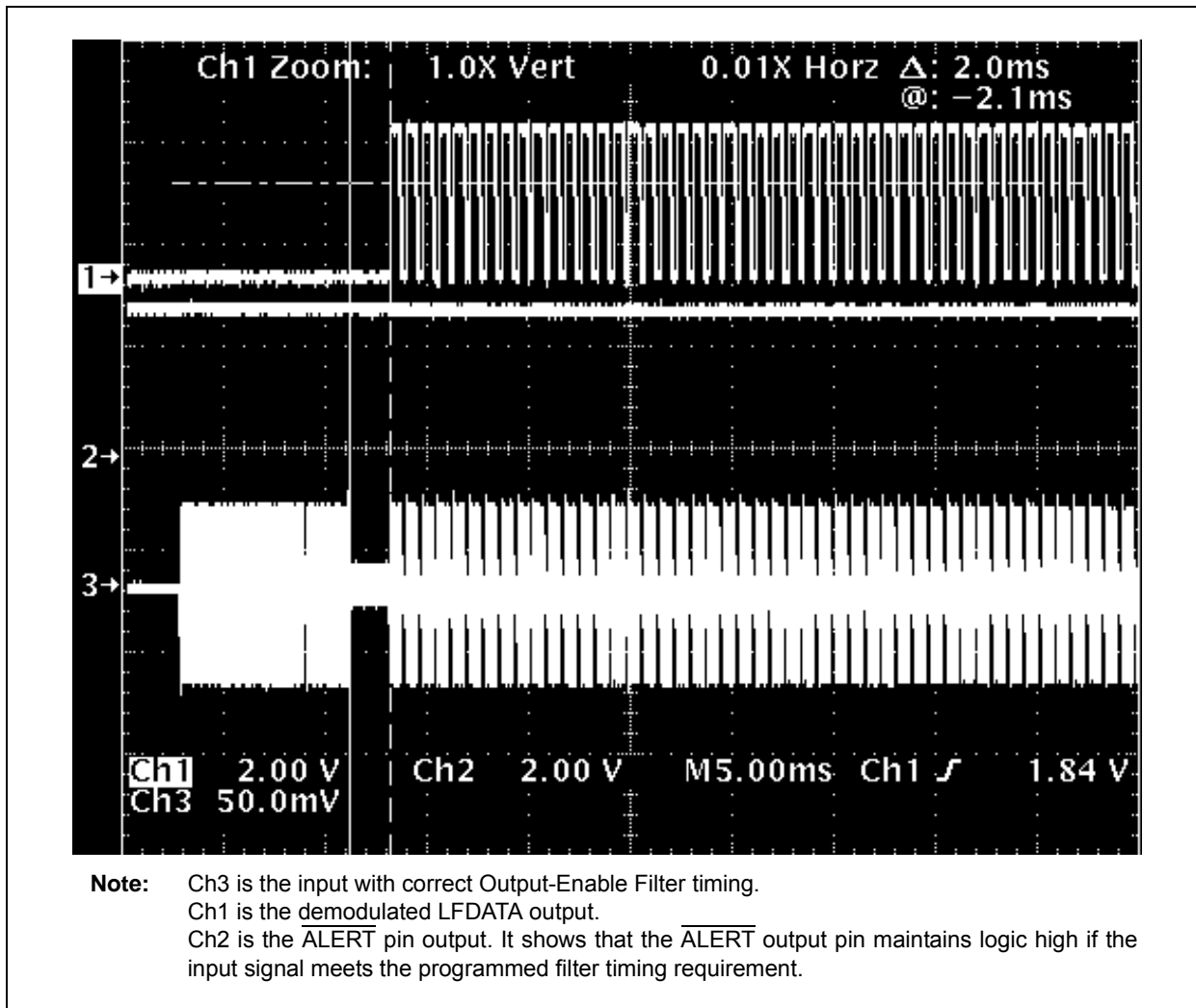

FIGURE 2-16: $\overline{\text{ALERT}}$ Output Example: With No Parity Error and no 32 ms Alarm Timer Time-out.

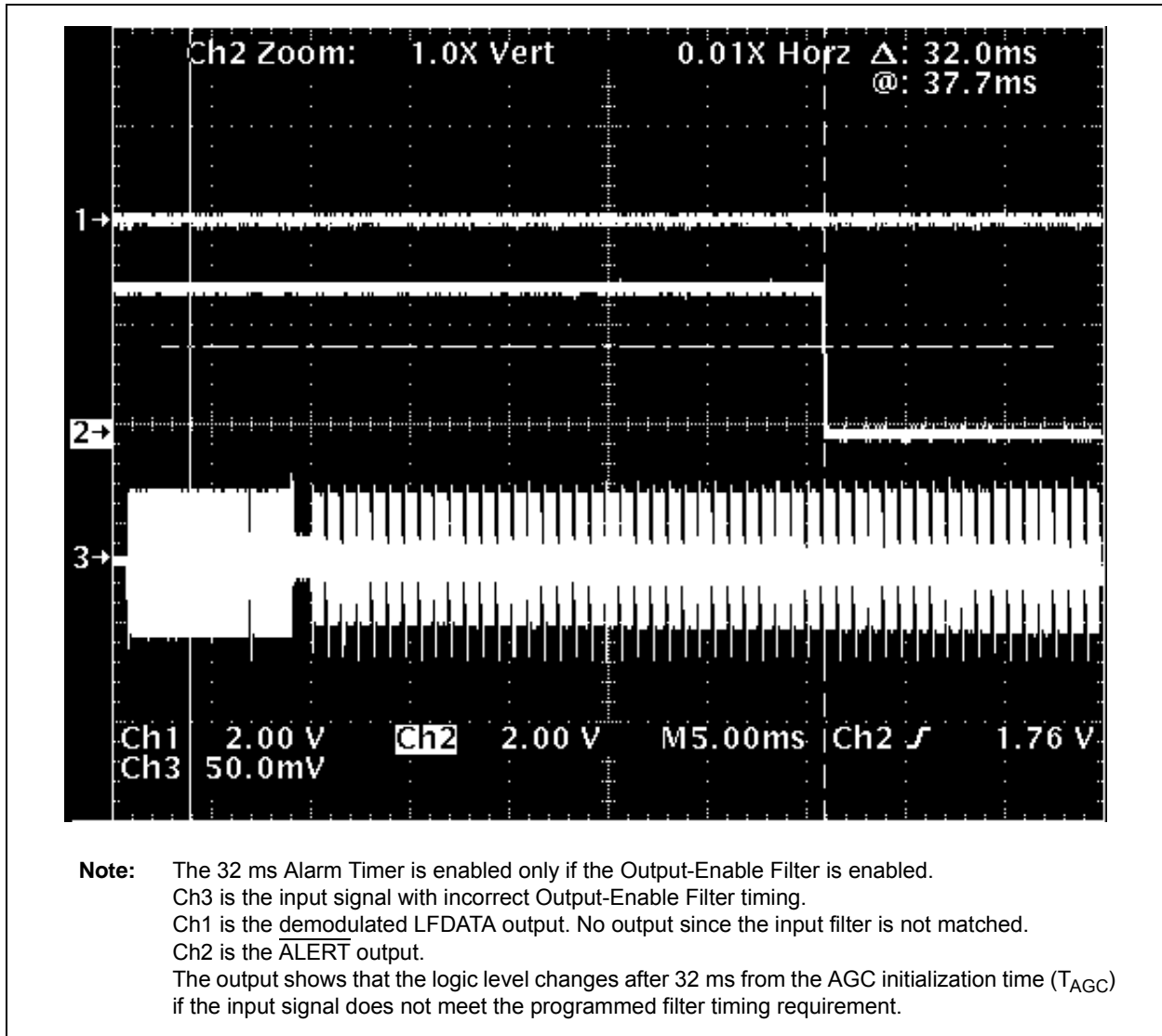

FIGURE 2-17: $\overline{\text{ALERT}}$ Output Example: With 32 ms Alarm Timer Timed-out.

MCP2030A

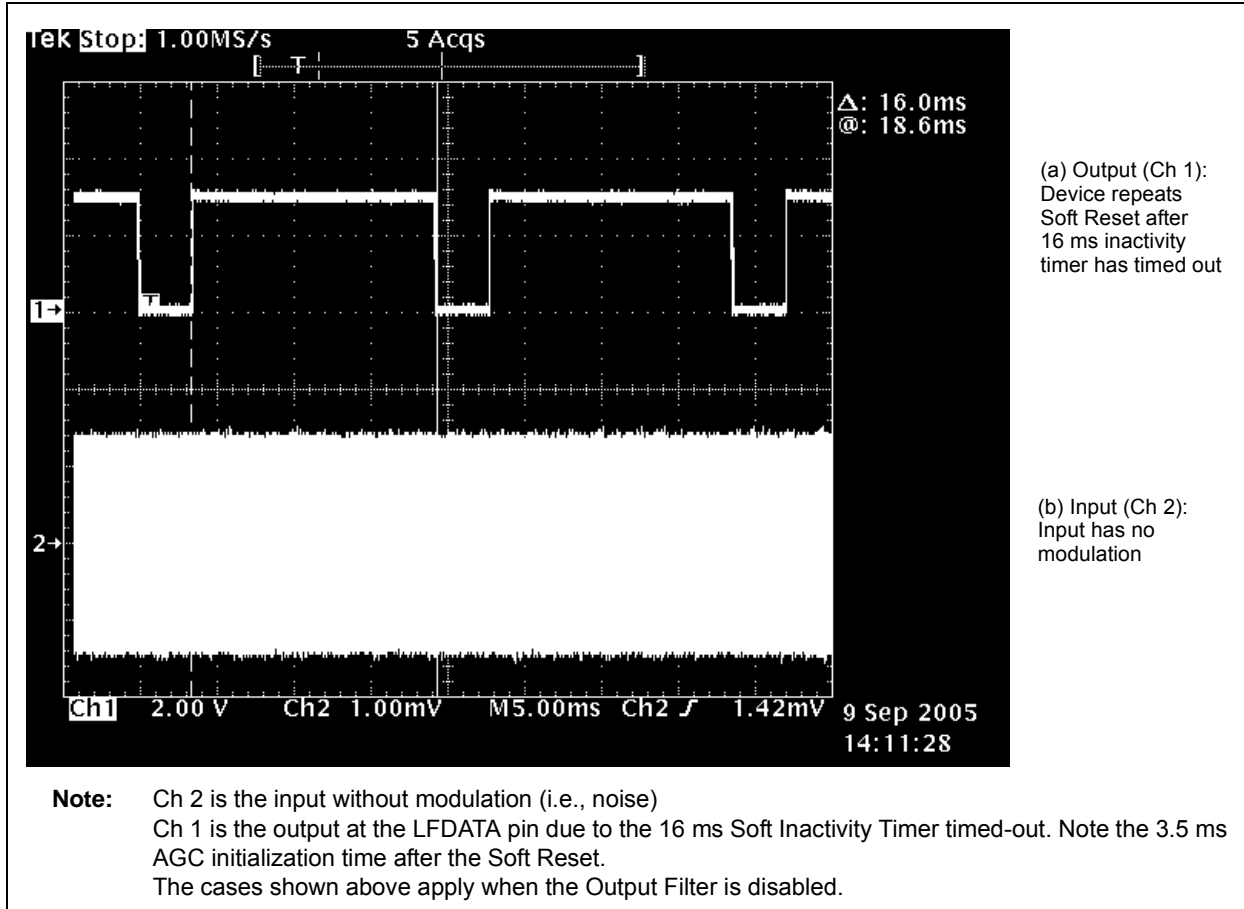

FIGURE 2-18: Examples of Soft Inactivity Timer Timed-out: This output is available only if the Output-Enable Filter is disabled.

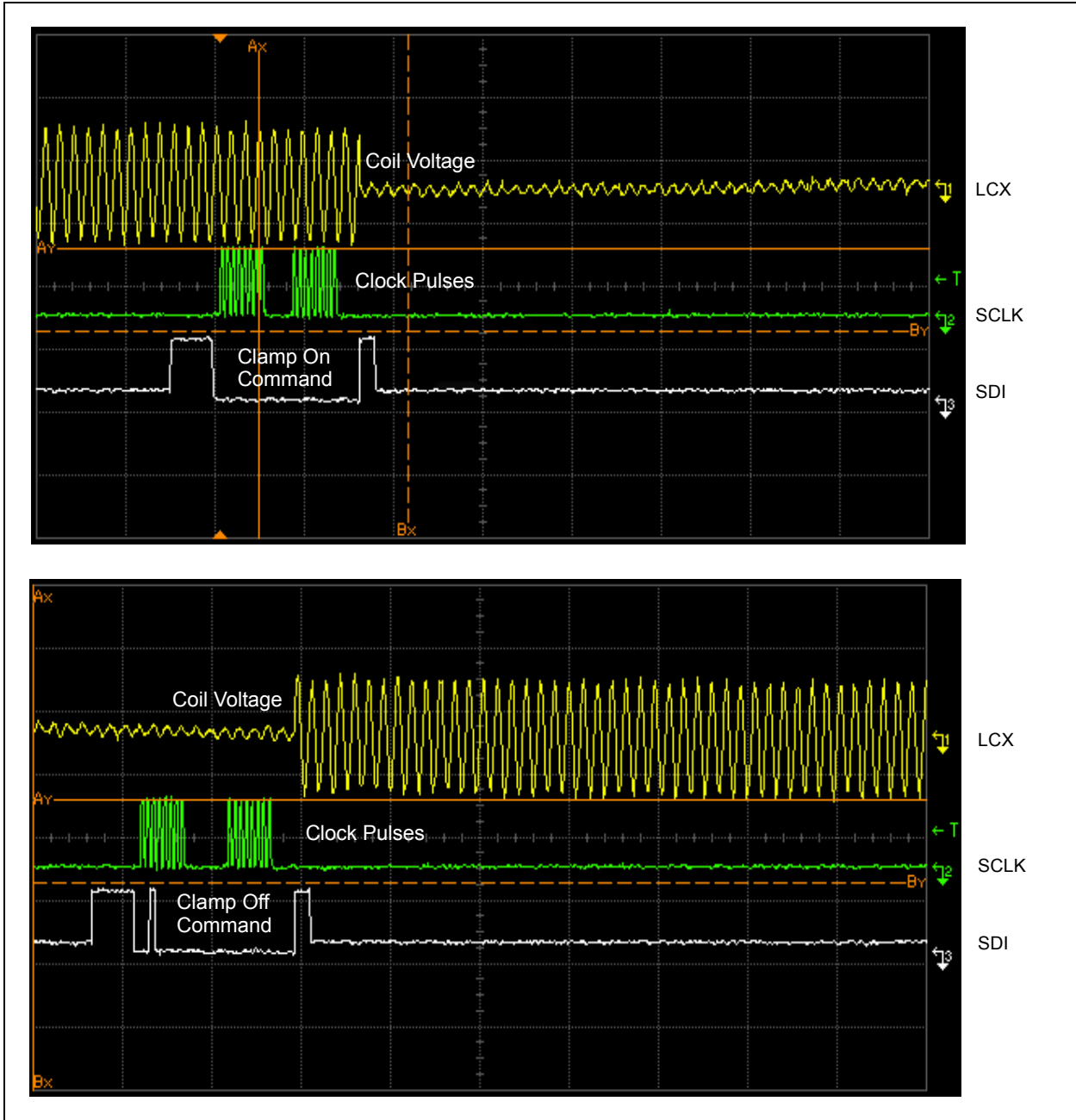

FIGURE 2-19: Examples of Clamp-On and Clamp-Off Commands and Changes in Coil Voltage.

MCP2030A

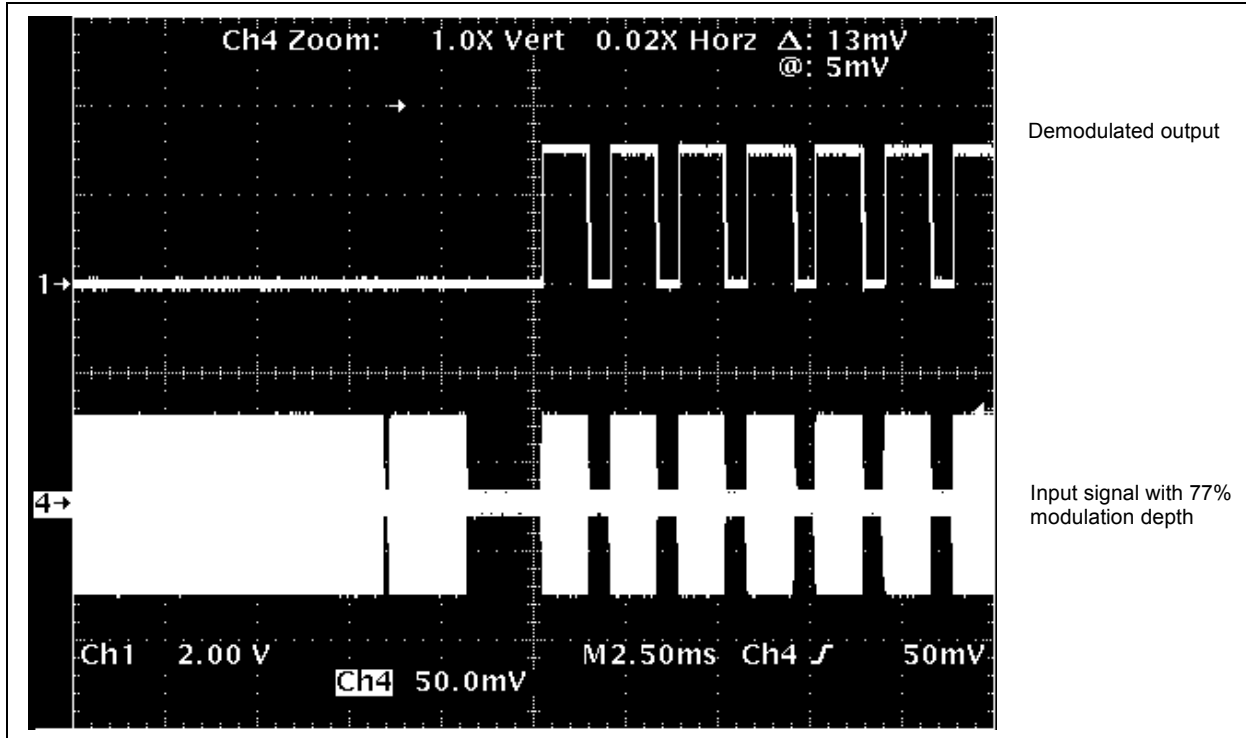
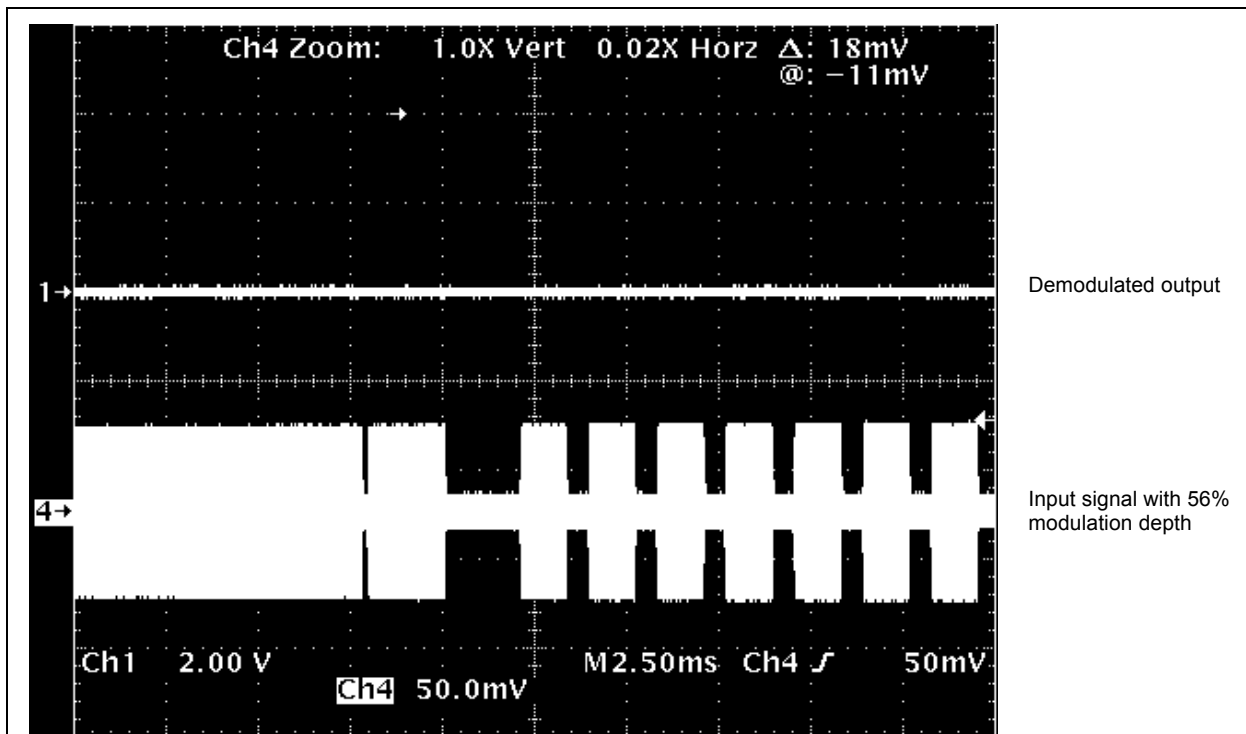

FIGURE 2-20: Example of Minimum Modulation Depth Setting: Modulation Depth of Input Signal = 77%, Minimum Modulation Depth (MODMIN) Setting = 60%.



Note: There is no demodulated output since the modulation depth of the input signal is lower than the minimum modulation depth setting. The device will have demodulated output if the Minimum Modulation Depth option is set to 8%, 14%, or 33%.

FIGURE 2-21: Example of Minimum Modulation Depth Setting: Modulation Depth of Input Signal = 56%, Minimum Modulation Depth (MODMIN) Setting = 60%.

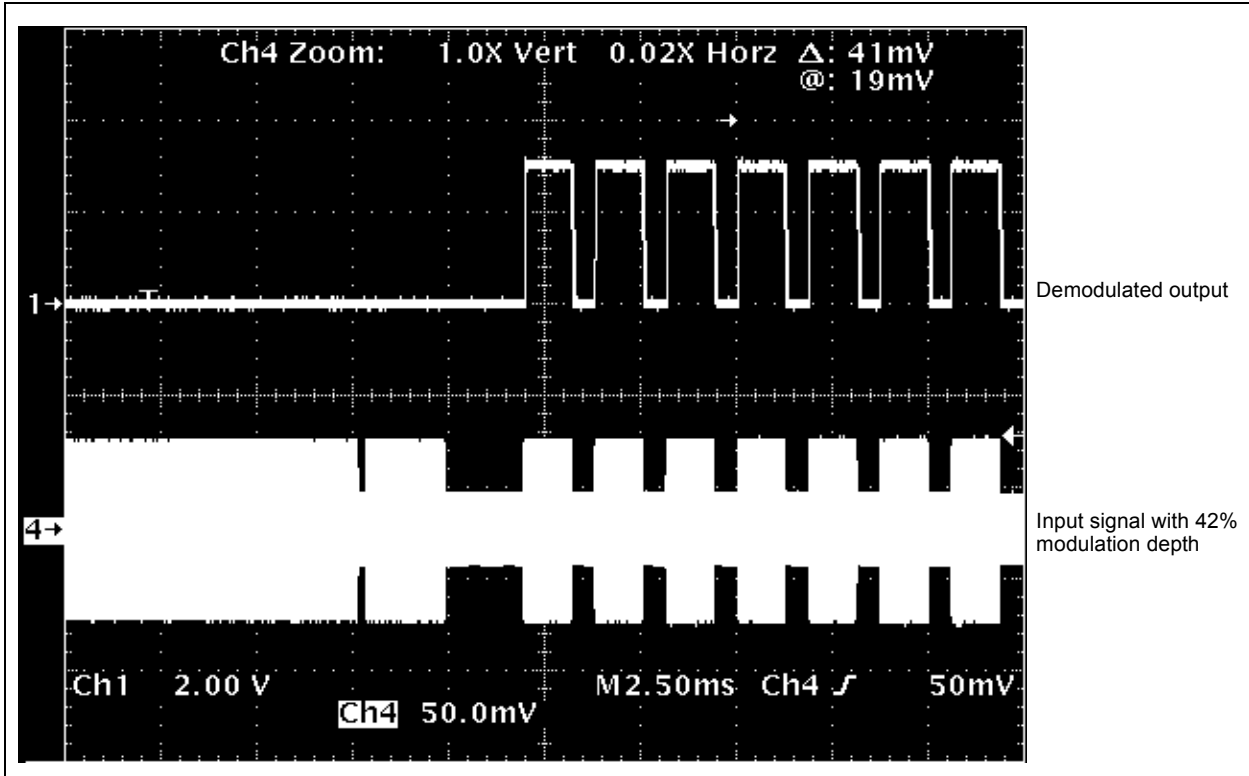

FIGURE 2-22: Example of Minimum Modulation Depth Setting: Modulation Depth of Input Signal = 42%, Minimum Modulation Depth (MODMIN) Setting = 33%.

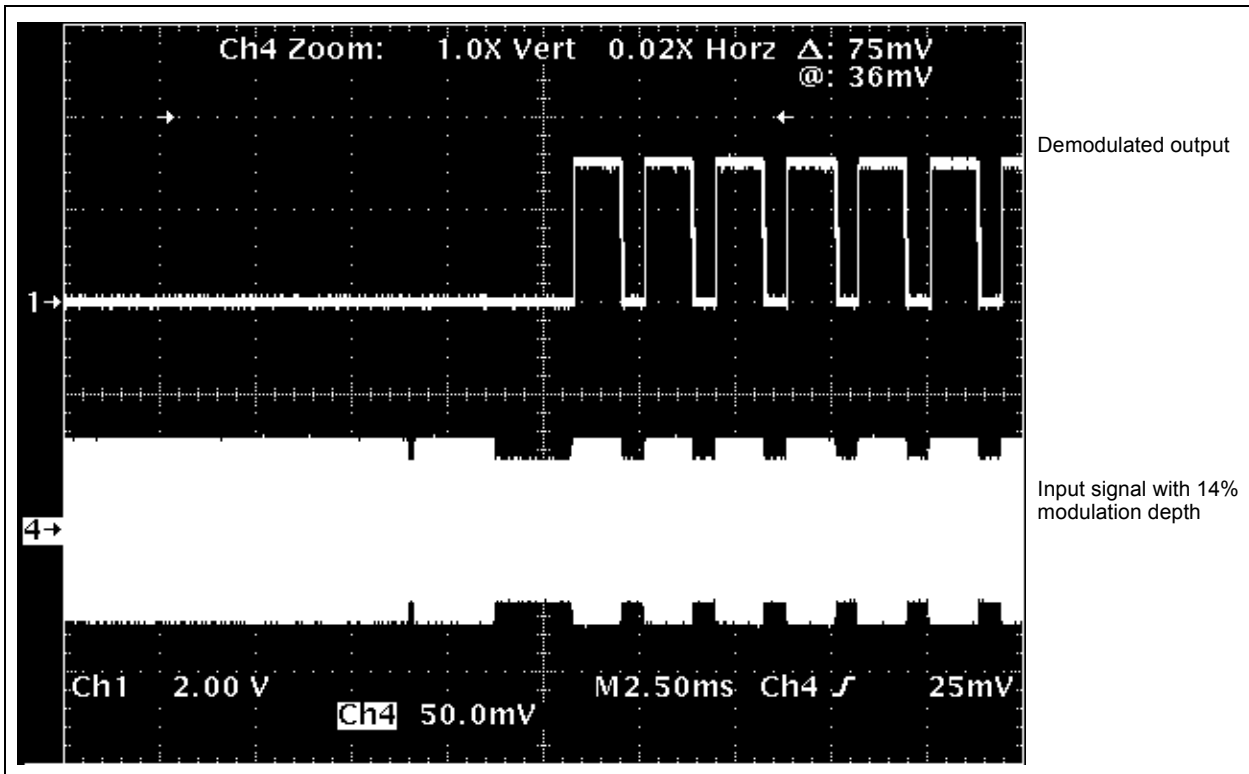

FIGURE 2-23: Example of Minimum Modulation Depth Setting: Modulation Depth of Input Signal = 14%, Minimum Modulation Depth (MODMIN) Setting = 14%.

MCP2030A

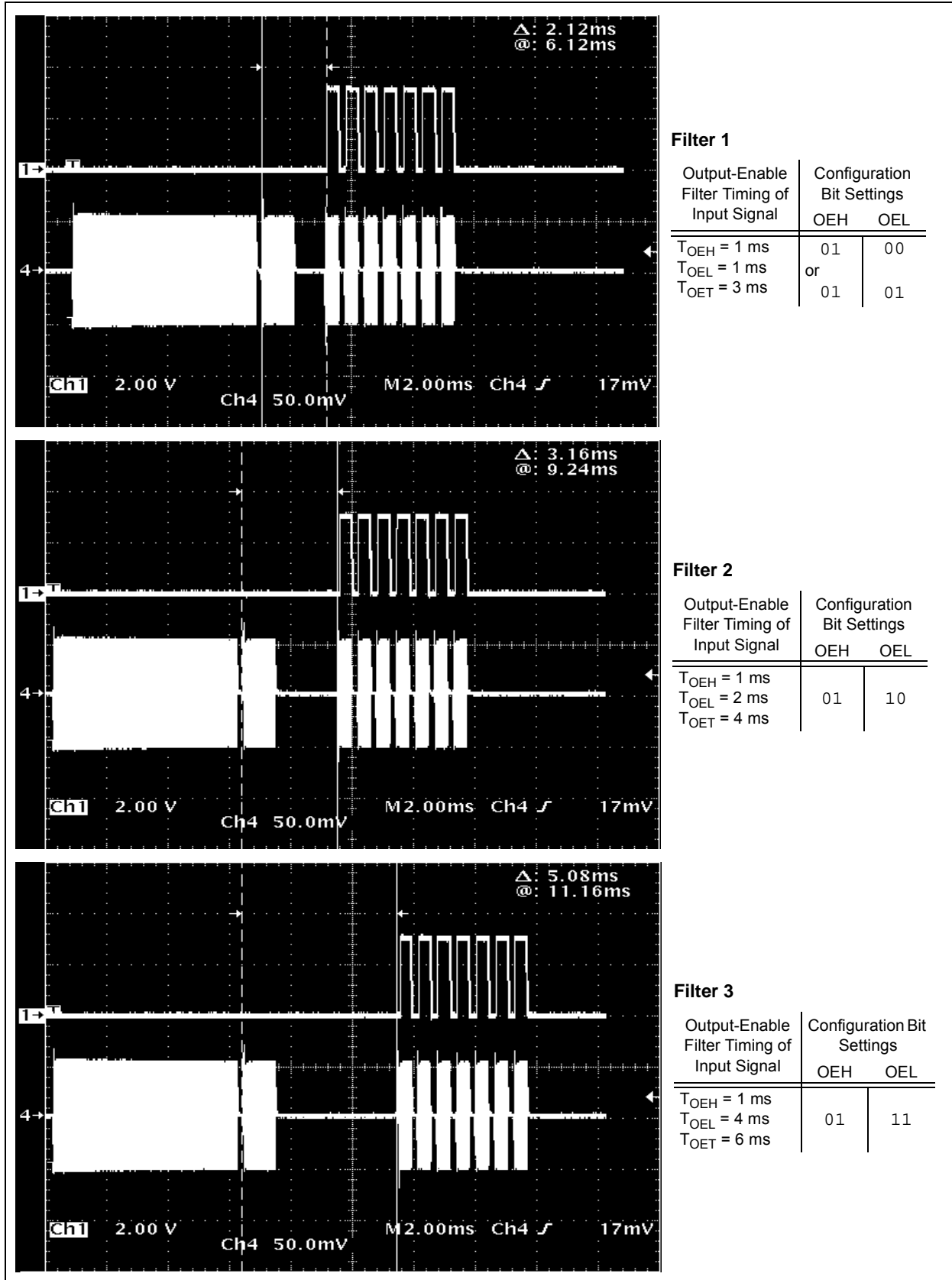

FIGURE 2-24: Examples of Output-Enable Filters 1 through 3 (Wake-up Filters) and Demodulated Outputs.

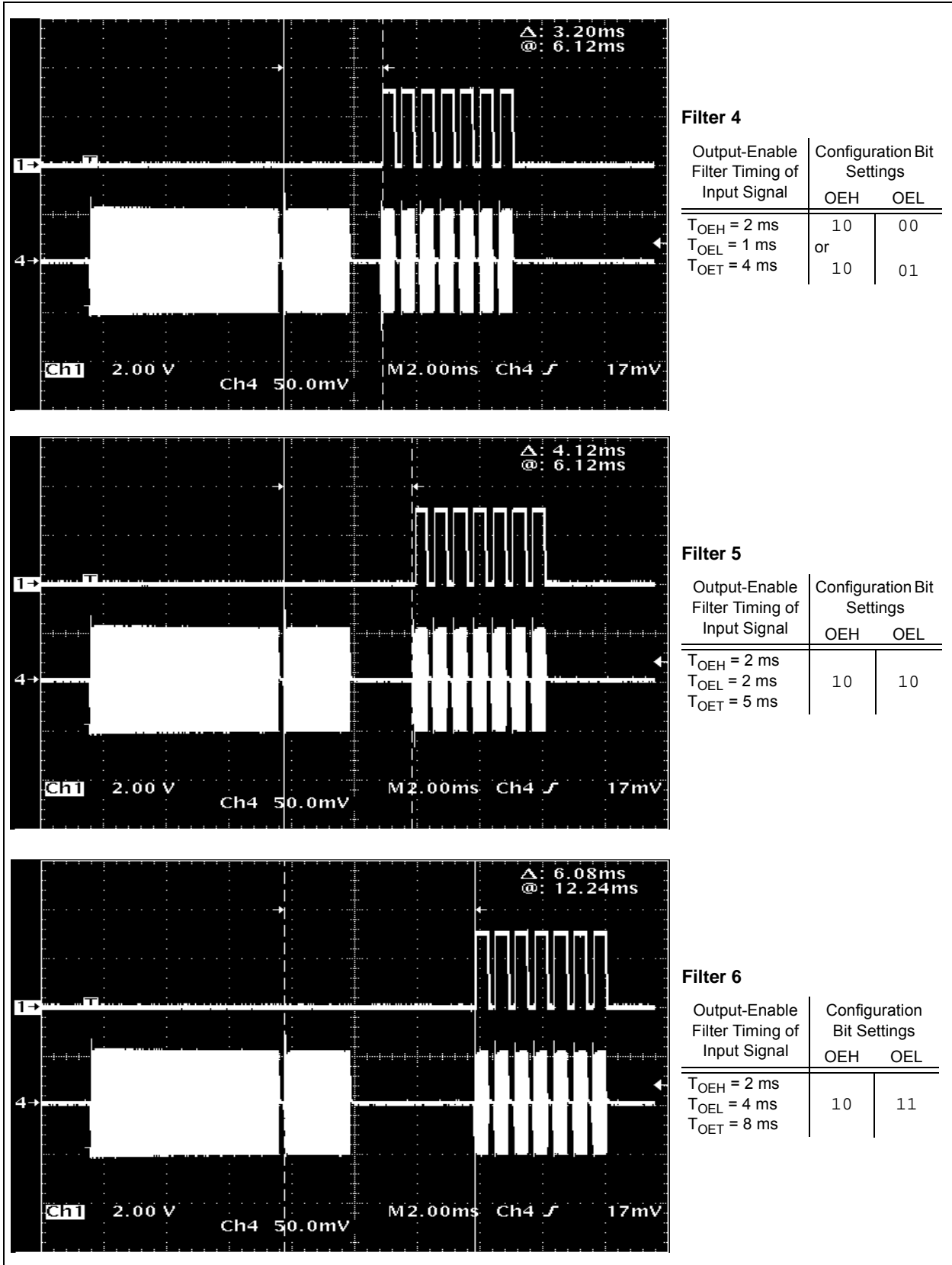

FIGURE 2-25: Examples of Output-Enable Filters 4 through 6 (Wake-up Filters) and Demodulated Outputs.

MCP2030A

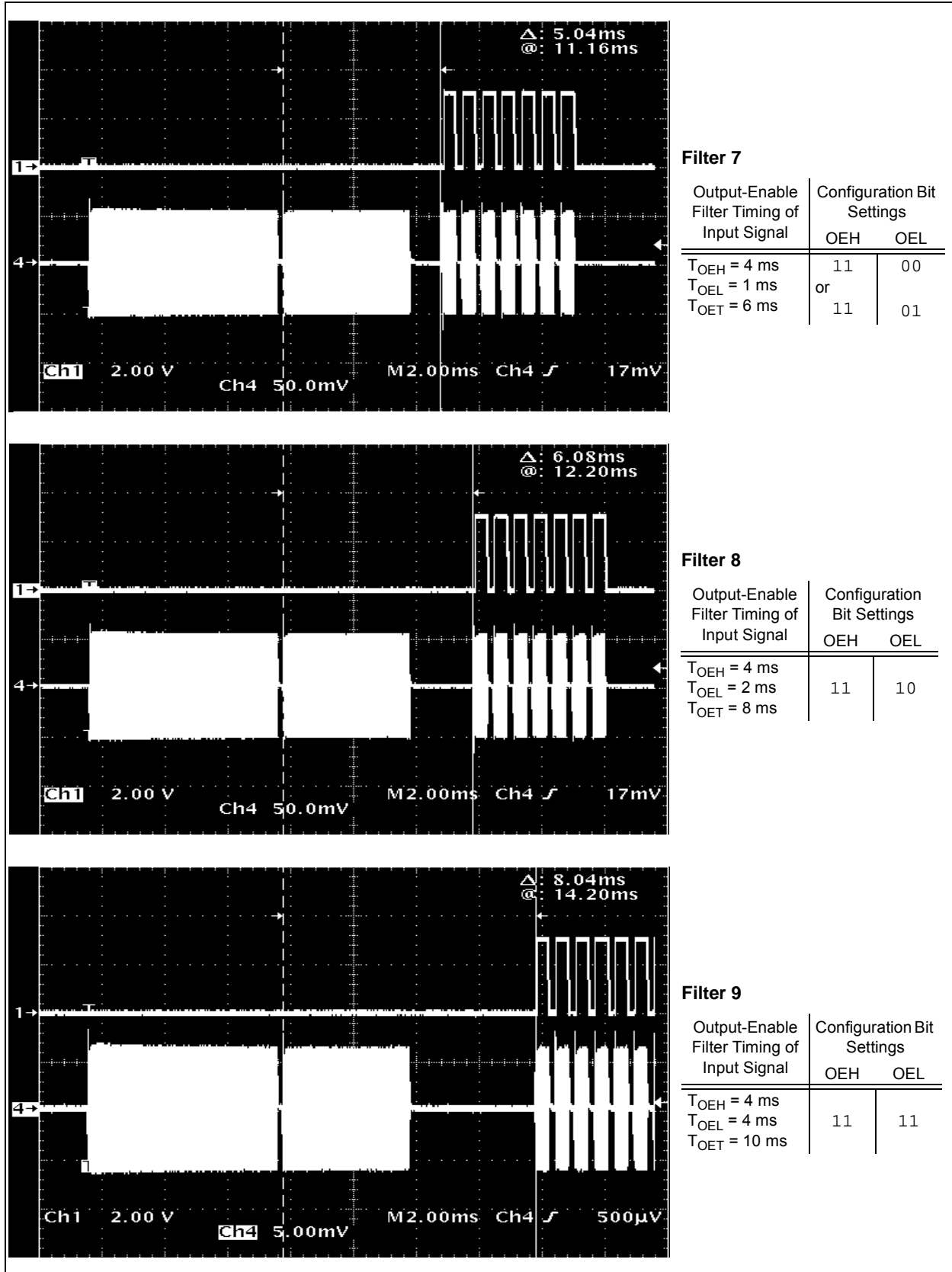

FIGURE 2-26: Examples of Output-Enable Filters 7 through 9 (Wake-up Filters) and Demodulated Outputs.

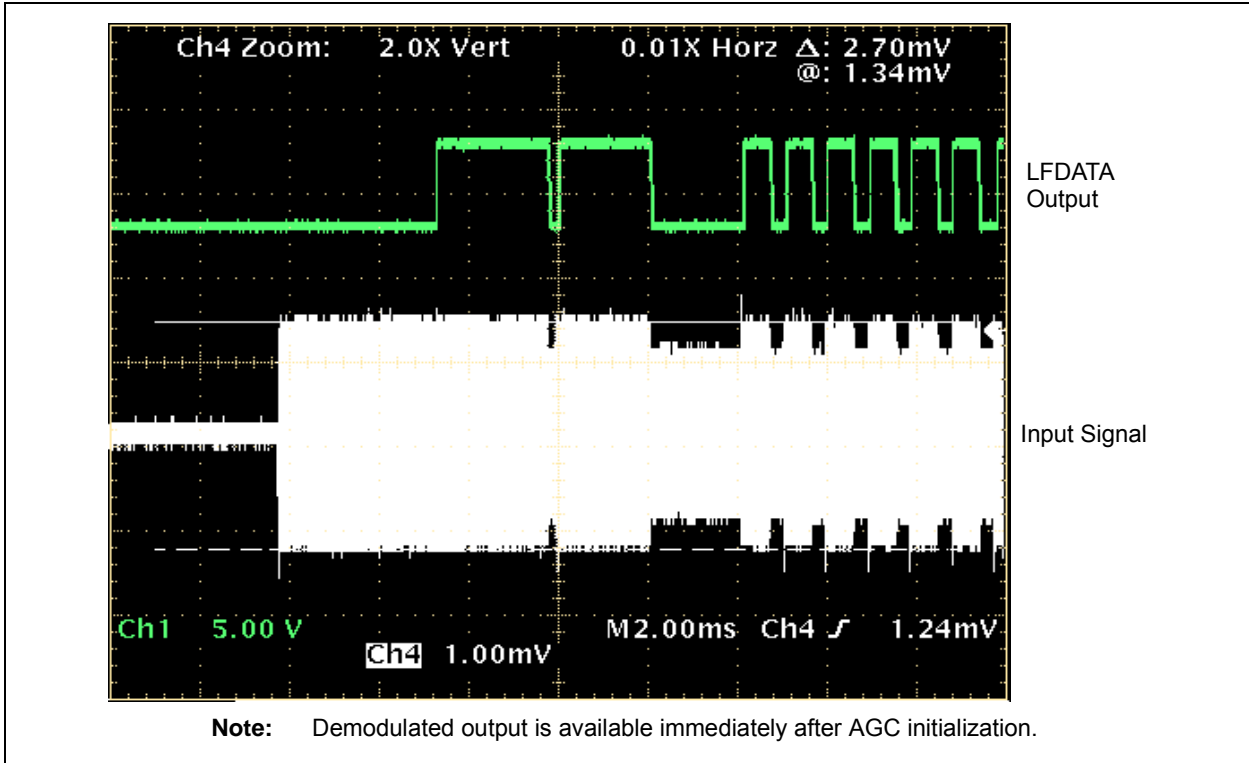

FIGURE 2-27: Input Signal and Demodulated Output When the Output-Enable Filter is Disabled.

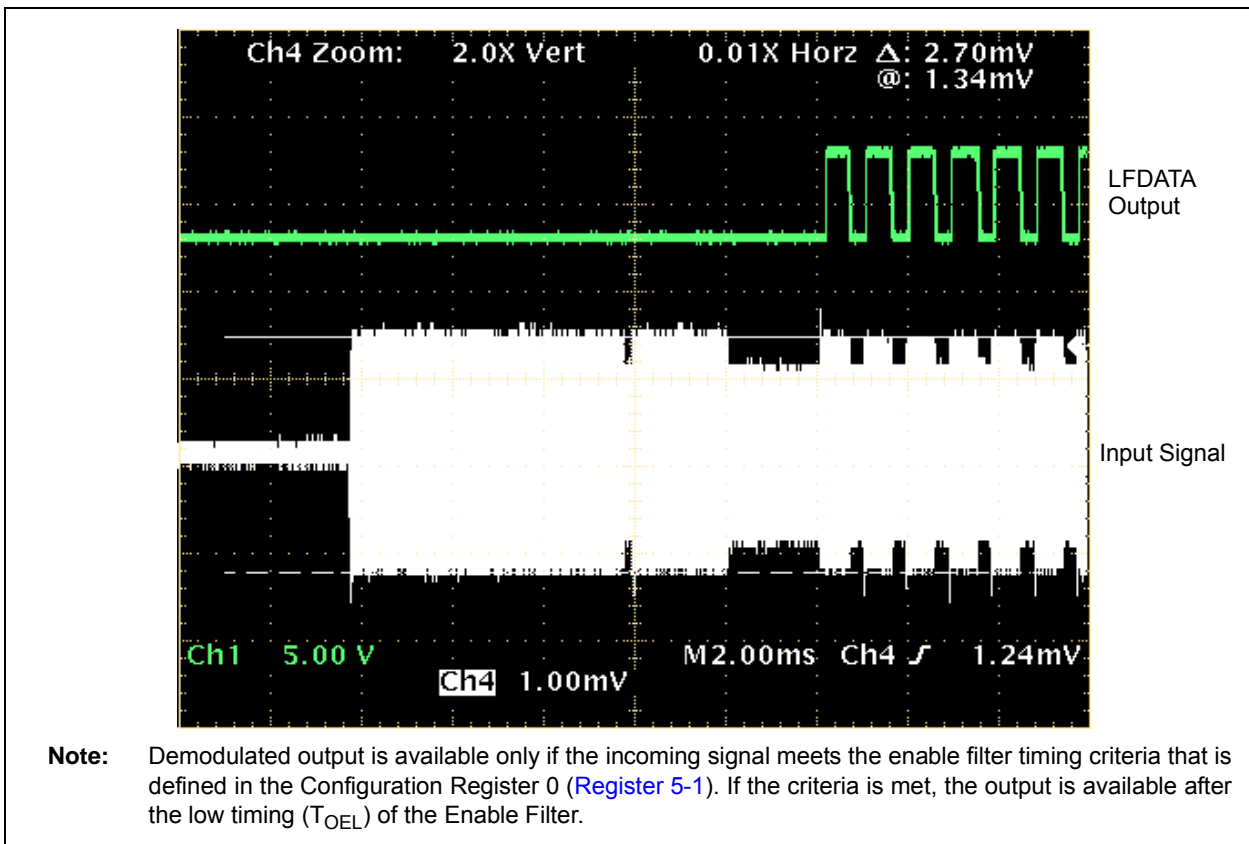

FIGURE 2-28: Input Signal and Demodulator Output When Output-Enable Filter is Enabled and Input Meets Filter Timing Requirements.

MCP2030A

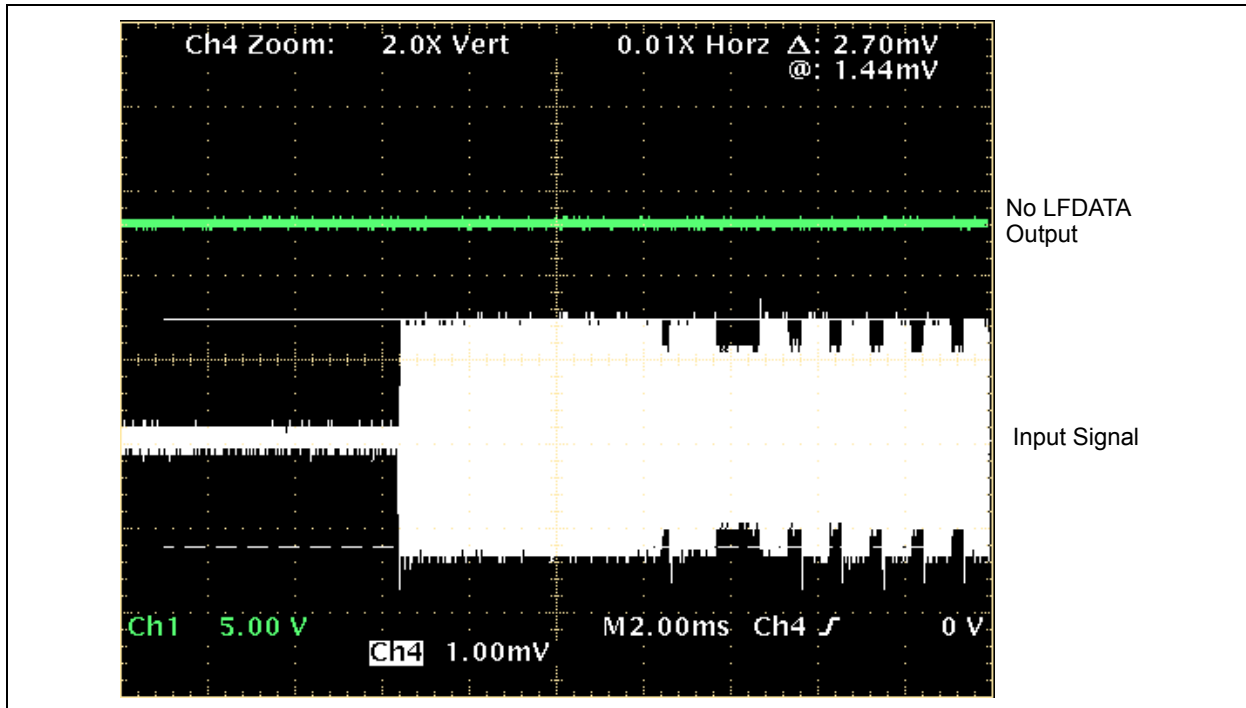

FIGURE 2-29: No Demodulator Output When Output-Enable Filter is Enabled But Input Does Not Meet Filter Timing Requirements.

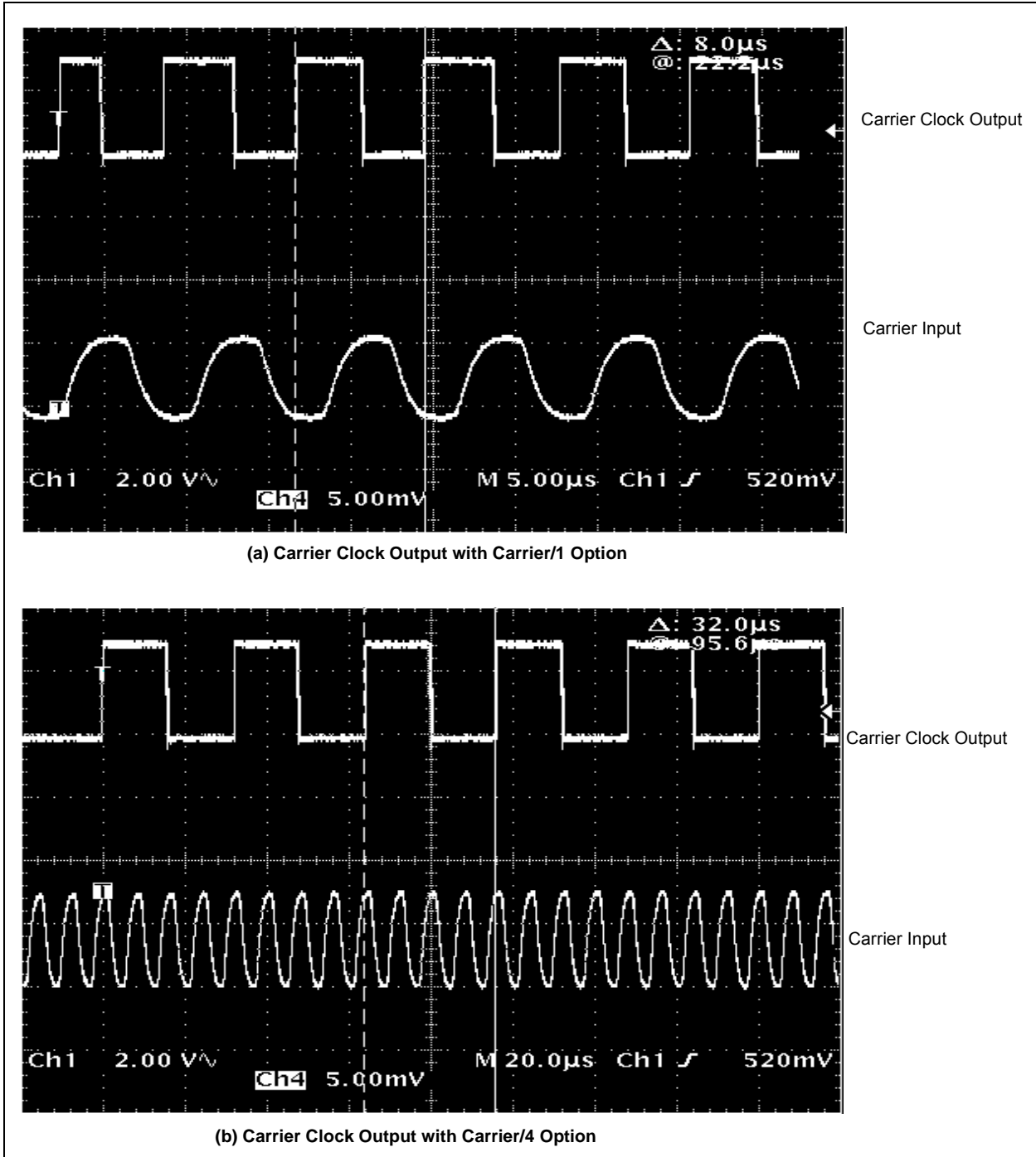

FIGURE 2-30: Carrier Clock Output Examples.

MCP2030A

NOTES:

3.0 PIN DESCRIPTIONS

The descriptions of the pins are listed in [Table 3-1](#).

TABLE 3-1: PIN FUNCTION TABLE

Pin No.	Symbol	I/O/P	Function
1	V_{SS}	P	Ground Pin.
2	\overline{CS}	I	Chip Select Digital Input Pin.
3	$SCLK/\overline{ALERT}$	I/O	Clock input for the modified 3-wire SPI interface. ALERT output: This pin goes low if there is a parity error in the configuration register or the 32 ms alarm timer is timed-out.
4	RSSI	O	Received Signal Strength Indicator (RSSI) current output.
5	NC	N/A	No Connect.
6	LFDATA/CCLK/SDIO	I/O	Demodulated data output. Carrier clock output. Serial input or output data for the modified 3-wire SPI interface.
7	V_{DD}	P	Positive Supply Voltage Pin.
8	V_{DD}	P	Positive Supply Voltage Pin.
9	LCZ	I	Input pin for external LC antennas.
10	LCY	I	Input pin for external LC antennas.
11	LCX	I	Input pin for external LC antennas.
12	NC	N/A	No Connect.
13	LCCOM	I	Common reference input for the external LC antennas.
14	V_{SS}	P	Ground Pin.

Legend: Type Identification: I = Input; O = Output; P = Power

3.1 Supply Voltage (V_{DD} , V_{SS})

The V_{DD} pin is the power supply pin for the analog and digital circuitry within the MCP2030A. This pin requires an appropriate bypass capacitor of 0.1 μ F. The voltage on this pin should be maintained in the 2.0V to 3.6V range for specified operation.

The V_{SS} pin is the ground pin and the current return path for both analog and digital circuitry of the MCP2030A. If an analog ground plane is available, it is recommended that this device be tied to the analog ground plane of the printed circuit board (PCB).

3.2 Chip Select (\overline{CS})

The \overline{CS} pin needs to stay high when the device is receiving input signals. Leaving the \overline{CS} pin low will place the device in the SPI programming mode.

The \overline{CS} pin is an open collector output. This pin has an internal pull-up resistor to ensure that no spurious SPI communication occurs between power-up and pin configuration of the MCU.

3.3 SPI Clock Input ($SCLK/\overline{ALERT}$)

This pin becomes the SPI clock input ($SCLK$) when \overline{CS} is low, and becomes the \overline{ALERT} output when \overline{CS} is high.

The \overline{ALERT} pin is an open-collector output. This pin has an internal pull-up resistor to ensure that no spurious SPI communication occurs between power-up and pin configuration of the MCU.

3.4 Received Signal Strength Indicator (RSSI)

This pin becomes the Received Signal Strength Indicator (RSSI) output current sink when the RSSI output option is selected.

MCP2030A

3.5 Demodulated Data Output (LFDATA) Carrier Clock Output (CCLK) SPI Data I/O (SDIO)

When the \overline{CS} pin is high, this pin is an output pin for demodulated data or carrier clock, depending on output type selection. When carrier clock output (CCLK) is selected, the LFDATA output is a square pulse of the input carrier clock and is available as soon as the AGC stabilization time (T_{STAB}) is completed.

When the \overline{CS} pin is low, this pin becomes the SPI data input and output (SDIO).

3.6 LC Input (LCX, LCY, LCZ)

These pins are the input pins for the external LC resonant antenna circuits. The antenna circuits are connected between the LC pin and the LCCOM pin.

3.7 LC Common Reference (LCCOM)

This pin is the common reference input pin for the external LC resonant circuit.

4.0 APPLICATION INFORMATION

The MCP2030A is a stand-alone 3-channel analog front-end device for low frequency (LF) sensing and bidirectional transponder applications. By connecting three orthogonally-placed LC resonant antennas to the LC input pins, it can detect signals from all directions (x, y, and z).

The device draws more current when all channels are enabled as compared to a single channel; therefore, it is recommended to disable any unused channels by setting Configuration Register 0 (Register 5-1).

The device's high input sensitivity (as low as 1 mV_{PP}) and ability to detect weakly modulated input signals (as low as 8%) with its low power feature set, makes the device suitable for various applications such as a low-cost hands-free Passive Keyless Entry (PKE) transponder, an LF Initiator sensor for Tire Pressure Monitoring Systems (TPMS) and long-range access control applications in the automotive and security industries.

4.1 Battery Back-up and Batteryless Operation

The device supports both battery back-up and batteryless operation by the addition of external components, allowing the device to be partially or completely powered from the field.

Figure 4-1 shows an example of the external circuit for the battery back-up.

Note: Voltage on LCCOM combined with coil input voltage must not exceed the maximum LC input voltage.

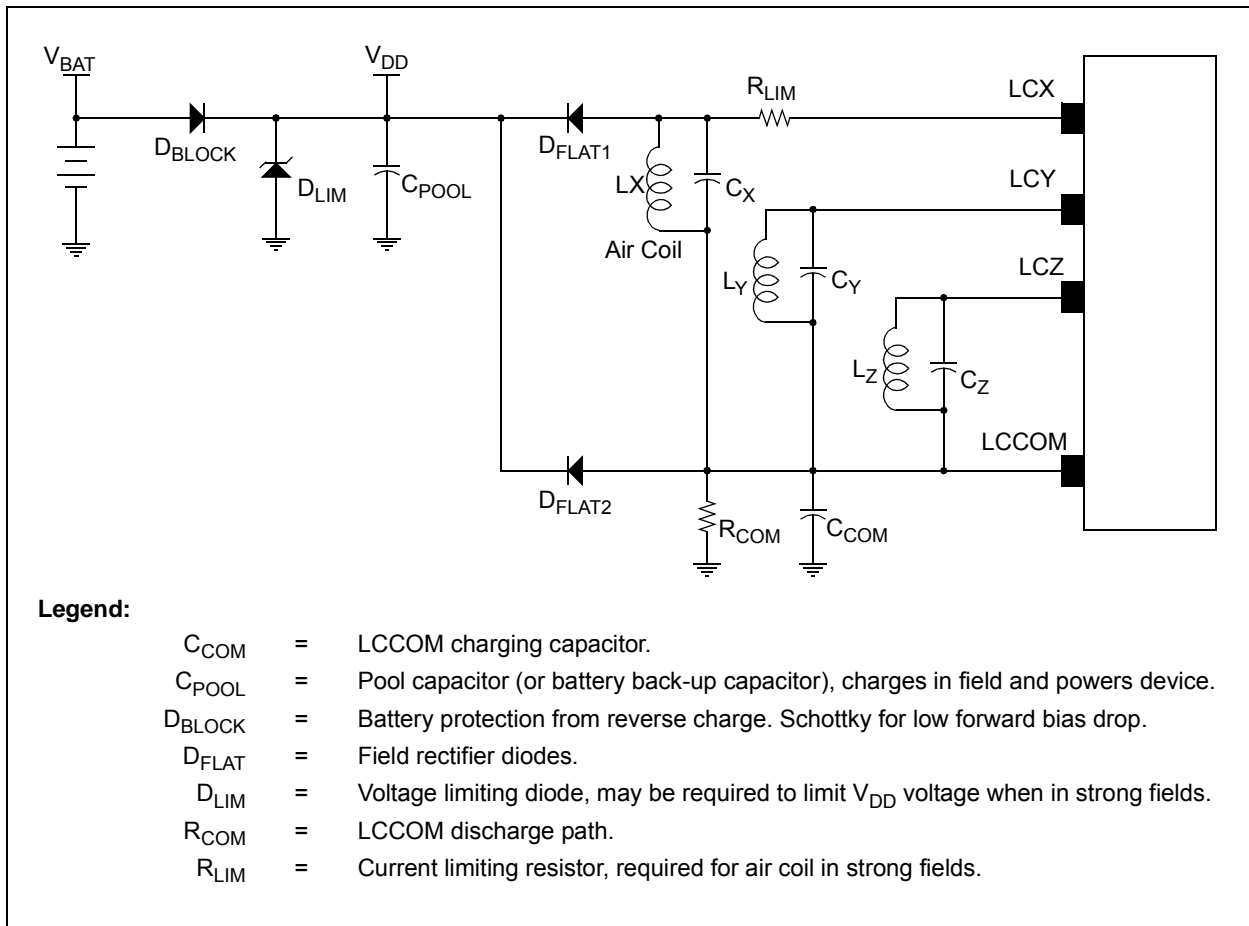

FIGURE 4-1: External Circuit Example for LF Field Powering and Battery Backup Mode.

MCP2030A

4.2 Application Examples

Figure 4-2 shows an example of an external circuit for a bidirectional communication transponder application.

Each LC input pin is connected to an external LC resonant circuit. To achieve the best performance, the resonant frequency of the LC circuit needs to be matched to the detecting carrier frequency of interest. The resonant frequency is given by Equation 4-1:

EQUATION 4-1:

$$f_o = \frac{1}{2\pi\sqrt{LC}}$$

In typical 125 kHz applications, the L value is a few mH, and the C value is a few hundred pF, for example, L = 4.9 mH, and C = 331 pF.

The resonant frequency can be fine-tuned by programming the internal tuning capacitors.

The output of the MCP2030A is fed into the external MCU. The external MCU can send data by clamping on and clamping off the MCP2030A coil voltages using an SPI command, or via a UHF transmitter.

The RSSI output of the MCP2030A can be digitized by the MCU firmware. Users can also consider using a MCU that has an internal analog-to-digital converter (ADC) such as the PIC16F684 or a stand-alone ADC device.

Figure 4-3 shows an example of a hands-free Passive Keyless Entry (PKE) system. The base station unit transmits an LF command. The MCP2030A detects the base station command and feeds the detected output to the external MCU (PIC16F636). If the command is correct, the MCU responds via an external UHF transmitter or by using the LF talk-back modulators of the MCP2030A device.

Figure 4-4 shows an example of the device being used for a tire pressure monitoring sensor application. The device detects the LF Initiator commands and transmits the tire pressure data to the base station via an external UHF transmitter.

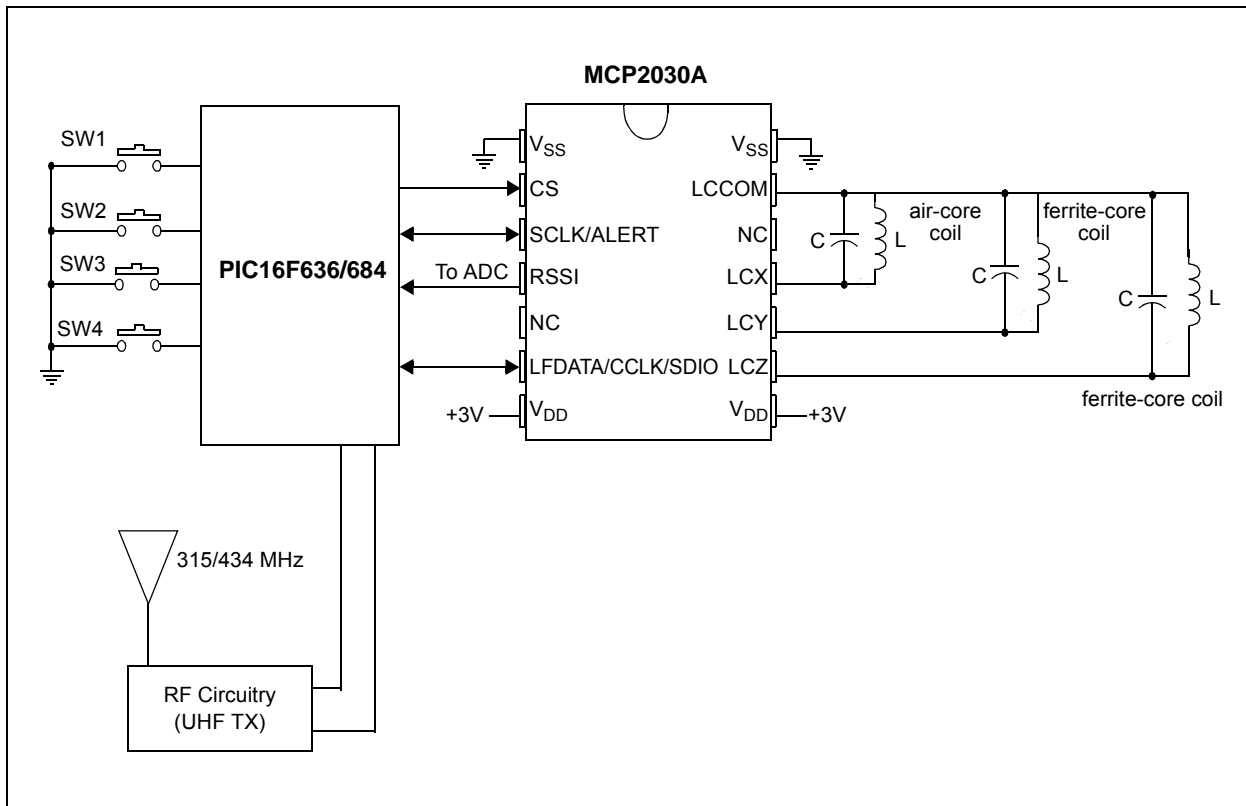

FIGURE 4-2: Example of External Circuits for Bidirectional Communication Transponder Applications.

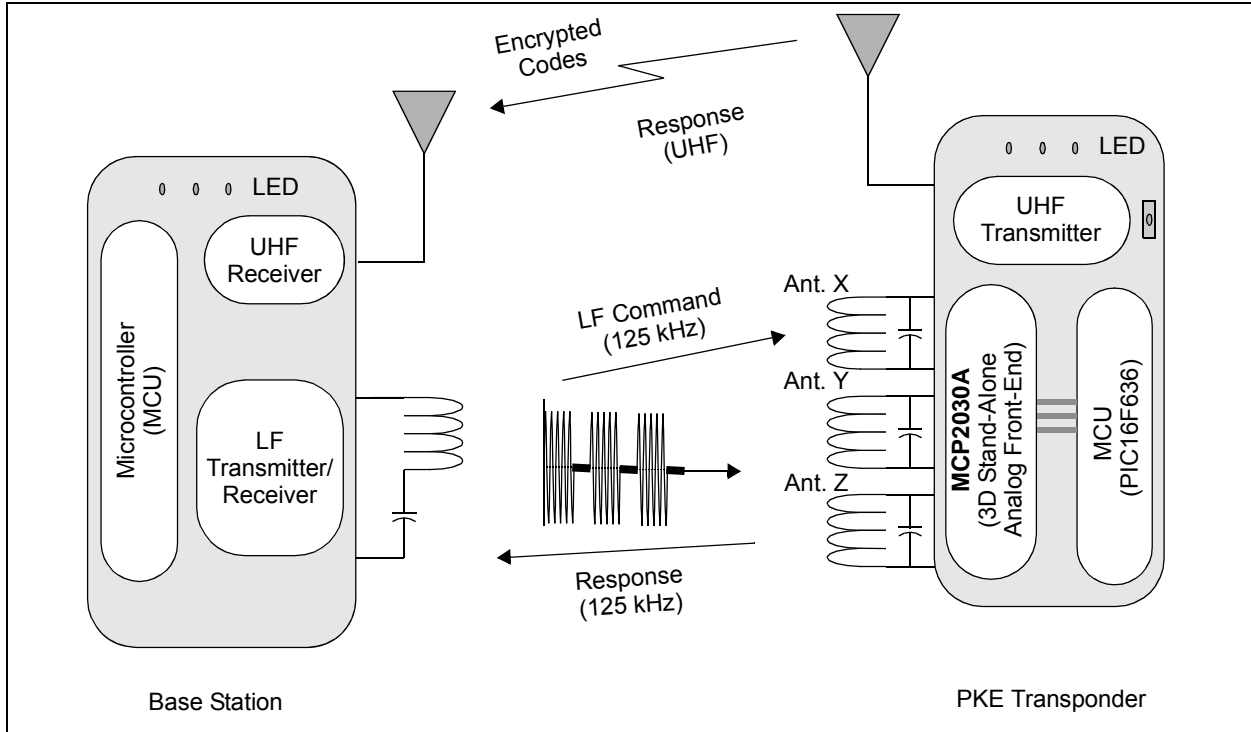

FIGURE 4-3: Example of Bidirectional Hands-free Passive Keyless Entry (PKE) System.

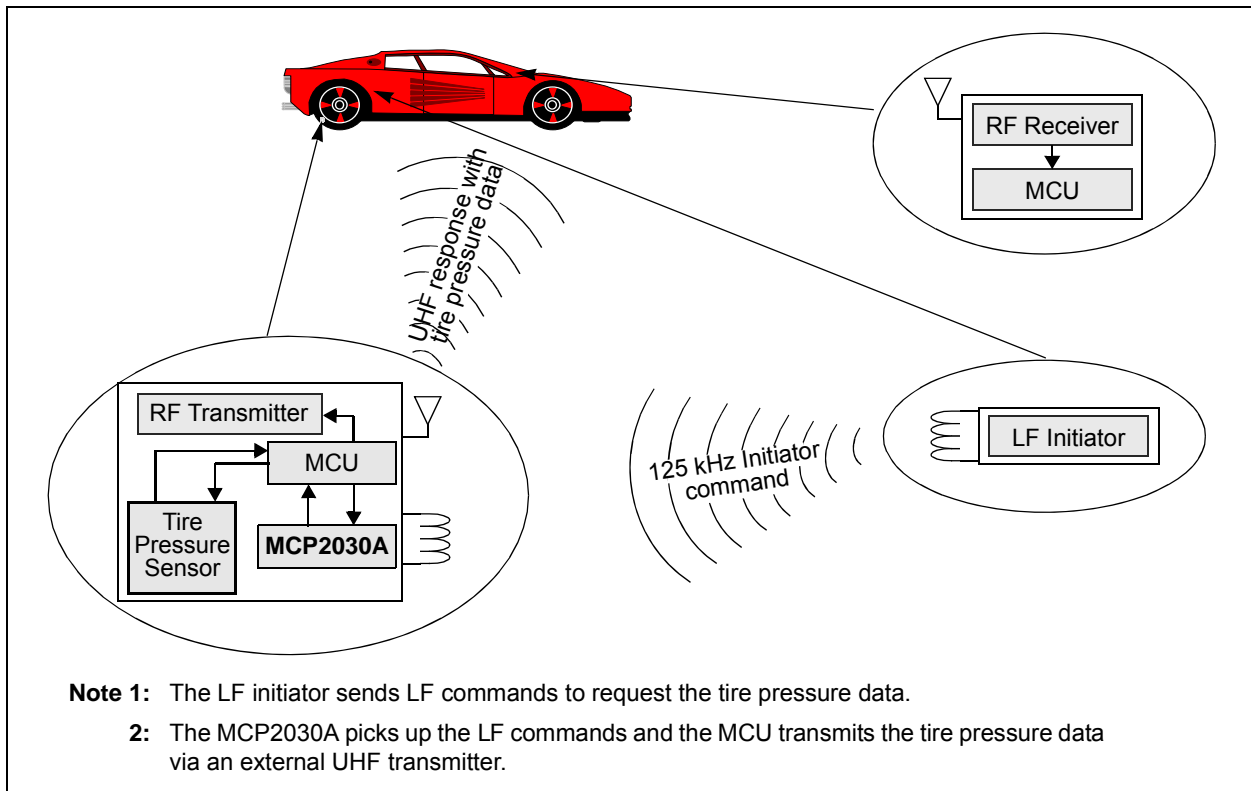

FIGURE 4-4: Example of Tire Pressure Monitoring Sensor Applications.

MCP2030A

NOTES:

5.0 FUNCTIONAL DESCRIPTION AND THEORY OF DEVICE OPERATION

The MCP2030A contains three analog-input channels for signal detection and LF talk-back. This section provides the function description of the device.

Each analog input channel has internal tuning capacitors, sensitivity control circuits, an input signal strength limiter and an LF talk-back modulation transistor. An Automatic Gain Control (AGC) loop is used for all three input channel gains. The output of each channel is ORED and fed into a demodulator. The digital output is passed to the LFDATA pin. [Figure 5-1](#) shows the block diagram of the device and [Figure 5-2](#) shows the input signal path.

There are a total of eight Configuration registers. Six of them are used for device operation options, one for column parity bits and one for status indication of device operation. Each register has nine bits, including one row parity bit. These registers are readable and writable by SPI commands; except for the STATUS register, which is read-only.

The device's features are dynamically controllable by programming the Configuration registers.

5.1 RF Limiter

The RF Limiter limits LC pin input voltage by de-Q-ing the external LC resonant antenna circuit. The limiter begins de-Q-ing the external LC antenna when the input voltage exceeds V_{DE_Q} , progressively de-Q-ing harder to reduce the antenna input voltage.

The signal levels from all 3 channels are combined such that the limiter attenuates all 3 channels uniformly, in respect to the channel with the strongest signal.

5.2 Modulation Circuit

The modulation circuit consists of a modulation transistor (FET), internal tuning capacitors and external LC antenna components. The modulation transistor and the internal tuning capacitors are connected between the LC input pin and LCCOM pin. Each LC input has its own modulation transistor.

When the modulation transistor turns on, its low turn-on resistance (modulation resistance or R_M) clamps the induced LC antenna voltage. The coil voltage is minimized when the modulation transistor turns on and maximized when the modulation transistor turns off. The modulation transistor's low R_M results in a high modulation depth.

The LF talk-back is achieved by turning on and off the modulation transistor.

The modulation data comes from the external micro-controller section via the digital SPI as "Clamp On", "Clamp Off" commands. Only those inputs that are enabled will execute the clamp command. A basic block diagram of the modulation circuit is shown in [Figure 5-1](#) and [Figure 5-2](#).

The modulation FET is also shorted momentarily after Soft Reset and Inactivity Timer time-out.

5.3 Tuning Capacitor

Each channel has internal tuning capacitors for external antenna tuning. The capacitor values are programmed by the Configuration registers up to 63 pF, 1 pF per step.

Note: The user can control the tuning capacitor by programming the Configuration registers. See [Register 5-2](#) through [Register 5-4](#) for details.

5.4 Variable Attenuator

The variable attenuator is used to attenuate, via AGC control, the input signal voltage to avoid saturating the amplifiers and demodulators.

Note: The variable attenuator function is accomplished by the device itself. The user cannot control its function.

5.5 Sensitivity Control

The sensitivity of each channel can be reduced by the channel's Configuration register sensitivity setting. This is used to desensitize the channel from optimum.

Note: The user can desensitize the channel sensitivity by programming the Configuration registers. See [Register 5-5](#) and [Register 5-6](#) for details.

5.6 AGC Control

The AGC controls the variable attenuator to limit the internal signal voltage to avoid saturation of internal amplifiers and demodulators (Refer to [Section 5.4 "Variable Attenuator"](#)).

The signal levels from all 3 channels are combined such that the AGC attenuates all 3 channels uniformly in respect to the channel with the strongest signal.

Note: The AGC control function is accomplished by the device itself. The user cannot control its function.

MCP2030A

5.7 Fixed Gain Amplifiers 1 and 2

FGA1 and FGA2 provide a maximum two-stage gain of 40 dB.

Note: The user cannot control the gain of these two amplifiers.

5.8 Auto-Channel Selection

The auto-channel selection feature is enabled if the Auto-Channel Select bit AUTOCHSEL<8> in Configuration Register 5 (Register 5-6) is set, and disabled if the bit is cleared. When this feature is active (i.e., AUTOCHSE <8> = 1), the control circuit checks the demodulator output of each input channel immediately after the AGC settling time (T_{STAB}). If the output is high, it allows this channel to pass data, otherwise it is blocked.

The status of this operation is monitored by Status Register 7 bits <8:6> (Register 5-8). These bits indicate the current status of the channel selection activity, and automatically updates for every Soft Reset period. The auto-channel selection function resets after each Soft Reset (or after Inactivity Timer time-out). Therefore, the blocked channels are re-enabled after Soft Reset.

This feature can make the output signal cleaner by blocking any channel that was not high at the end of T_{AGC} . This function works only for demodulated data output, and is not applied for carrier clock or RSSI output.

5.9 Carrier Clock Detector

The Carrier Clock Detector senses the input carrier cycles. The output of the detector switches digitally at the signal carrier frequency. Carrier clock output is available when the output is selected by the DATOUT bit in Configuration Register 1 (Register 5-2).

5.10 Demodulator

The Demodulator consists of a full-wave rectifier, low-pass filter, peak detector and Data Slicer that detects the envelope of the input signal.

5.11 Data Slicer

The Data Slicer consists of a reference generator and comparator. The Data Slicer compares the input with the reference voltage. The reference voltage comes from the minimum modulation depth requirement setting and input peak voltage. The data from all 3 channels are ORed together and sent to the output-enable filter.

5.12 Output-Enable Filter

The output-enable filter enables the LFDATA output once the incoming signal meets the wake-up sequence requirements (see Section 5.15 “Configurable Output-Enable Filter”).

5.13 Received Signal Strength Indicator (RSSI)

The RSSI provides a current which is proportional to the input signal amplitude (see Section 5.30.3 “Received Signal Strength Indicator (RSSI Output”).

5.14 Analog Front-End Timers

The device has an internal 32 kHz RC oscillator. The oscillator is used in several timers:

- Inactivity Timer
- Alarm Timer
- Pulse Width Timer
- Period Timer
- AGC Settling Timer

5.14.1 RC OSCILLATOR

The RC oscillator generates a 32 kHz internal clock.

5.14.2 INACTIVITY TIMER

The Inactivity Timer is used to automatically return the device to Standby mode, if there is no input signal. The time-out period is approximately 16 ms (T_{INACT}), based on the 32 kHz internal clock.

The purpose of the Inactivity Timer is to minimize current draw by automatically returning to the lower current Standby mode if, for the T_{INACT} period, there is not an input signal.

The timer is reset when:

- An amplitude change occurs in LF input signal, either from high-to-low or low-to-high
- the \overline{CS} pin is low (any SPI command)
- a timer-related Soft Reset occurs

The timer starts after the AGC initialization period of time (T_{AGC}).

The timer causes a Soft Reset when, for the T_{INACT} period, a previously-received input signal does not change from either high-to-low or low-to-high.

The Soft Reset returns the device to Standby mode, where most of the analog circuits, such as the AGC, demodulator, and RC oscillator, are powered down. This returns the device to the lower Standby Current mode.

5.14.3 ALARM TIMER

The Alarm Timer is used to notify the external MCU that the device is receiving an input signal that does not pass the output-enable filter requirement. The time-out period is approximately 32 ms (T_{ALARM}) in the presence of continuing noise.

The Alarm Timer time-out occurs if there is an input signal for longer than 32 ms that does not meet the output-enable filter requirements. The Alarm Timer time-out causes:

- a) the \overline{ALERT} pin to go low
- b) the ALARM bit to set in the Status Register 7 (Register 5-8)

The external MCU is informed of the Alarm Timer time-out by monitoring the \overline{ALERT} pin. If the Alarm Timer time-out occurs, the external MCU can take appropriate actions, such as lowering channel sensitivity or disabling channels. If the noise source is ignored, the device can return to a lower Standby Current Draw state.

The timer is reset when the:

- the \overline{CS} pin is low (any SPI command)
- the output-enable filter is disabled
- the LFDATA pin is enabled (signal passed output-enable filter)

The timer starts after the T_{AGC} period.

The timer causes a low output on the \overline{ALERT} pin when the output-enable filter is enabled and modulated input signal is present for T_{ALARM} , but does not pass the output-enable filter requirement.

Note: The Alarm timer is disabled if the output-enable filter is disabled.

5.14.4 PULSE WIDTH TIMER

The Pulse Width Timer is used to verify that the received output enable sequence meets both the minimum T_{OEH} and minimum T_{OEL} requirements.

5.14.5 PERIOD TIMER

The Period Timer is used to verify that the received output enable sequence meets the maximum T_{OET} requirement.

5.14.6 AGC INITIALIZATION TIMER (T_{AGC})

This timer is used to keep the output-enable filter in Reset while the AGC settles on the input signal. The time-out period is approximately 3.5 ms. At end of this time (T_{AGC}), the input should remain high (T_{PAGC}), otherwise the counting is aborted and a Soft Reset is issued. See Figure 5-4 for details.

Note 1: The device needs continuous and uninterrupted high input signal during AGC initialization time (T_{AGC}). Any absence of signal during this time may reset the timer and a new input signal is needed for AGC settling time, or may result in improper AGC gain settings which will produce invalid output.

2: The rest of the device section wakes up if any of these input channels receive the AGC settling time correctly. Status Register 7 bits <4:2> (Register 5-8) indicate which input channels woke the device first. Valid input signal on multiple input pins can cause the indicator bit to be set on more than one channel.

MCP2030A

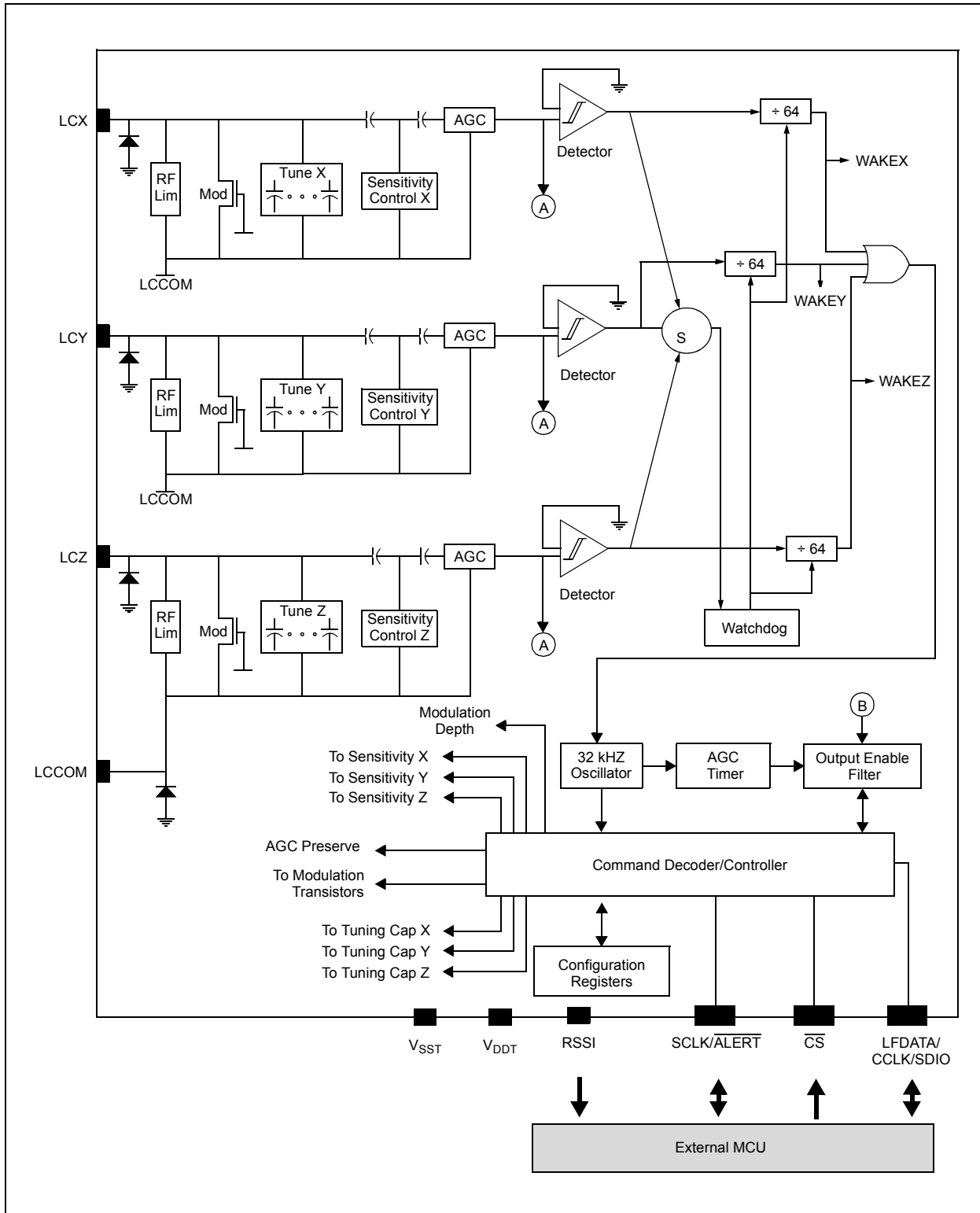

FIGURE 5-1: Functional Block Diagram.

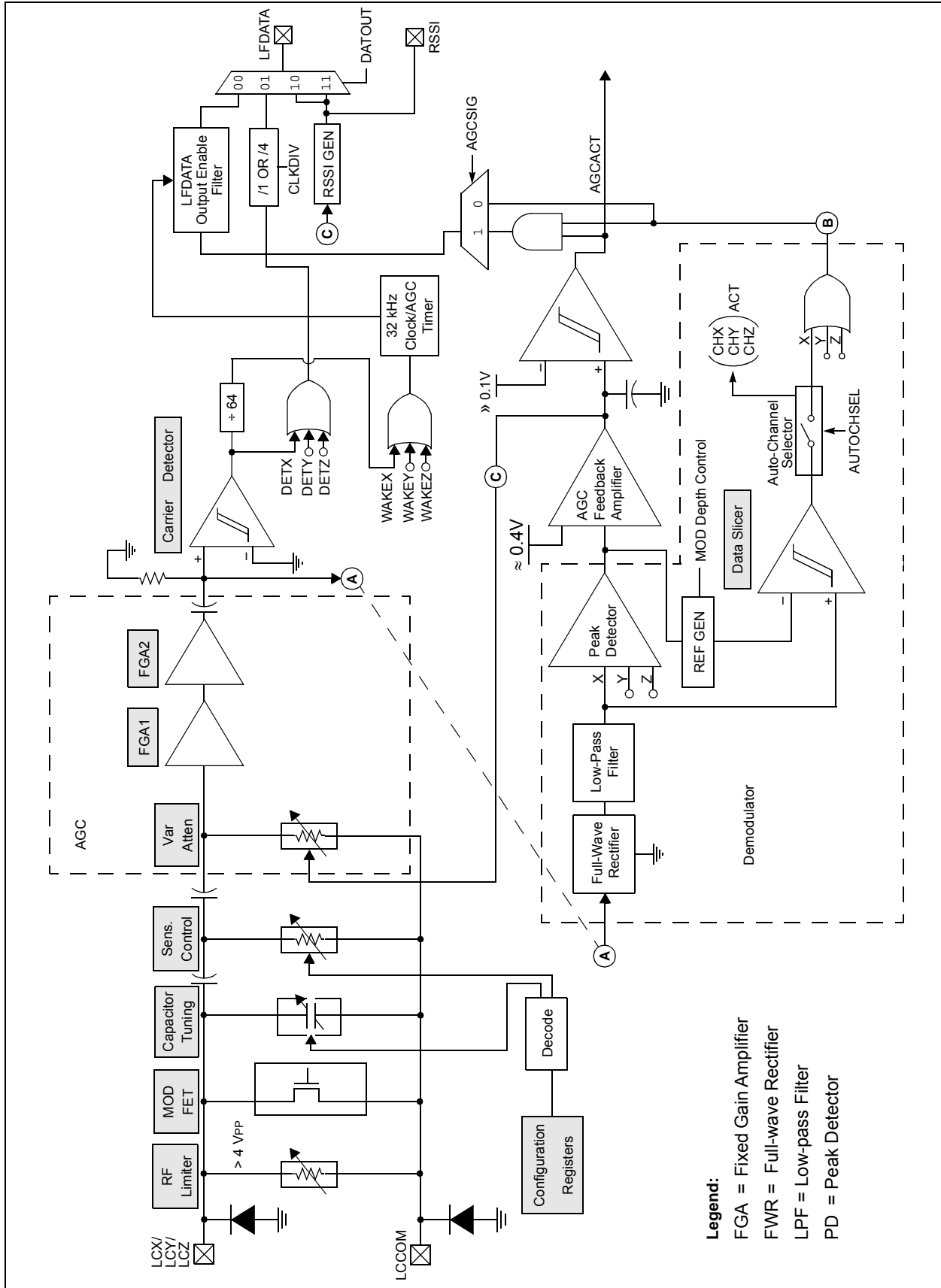

FIGURE 5-2: Input Signal Path.

MCP2030A

5.15 Configurable Output-Enable Filter

The purpose of this filter is to enable the LFDATA output and wake the external microcontroller only after receiving a specific sequence of pulses on the LC input pins. Therefore, it prevents waking up the external microcontroller due to noise or unwanted input signals. The circuit compares the timing of the demodulated header waveform with a pre-defined value, and enables the demodulated LFDATA output when a match occurs.

The output-enable filter consists of a high (T_{OEH}) and low (T_{OEL}) duration of a pulse immediately after the AGC settling gap time. The selection of high and low times further implies a maximum period of time. The output-enable high and low times are determined by SPI programming. Figure 5-3 and Figure 5-4 show the output-enable filter waveforms.

There should be no missing cycles during T_{OEH} . Missing cycles may result in failing the output-enable condition.

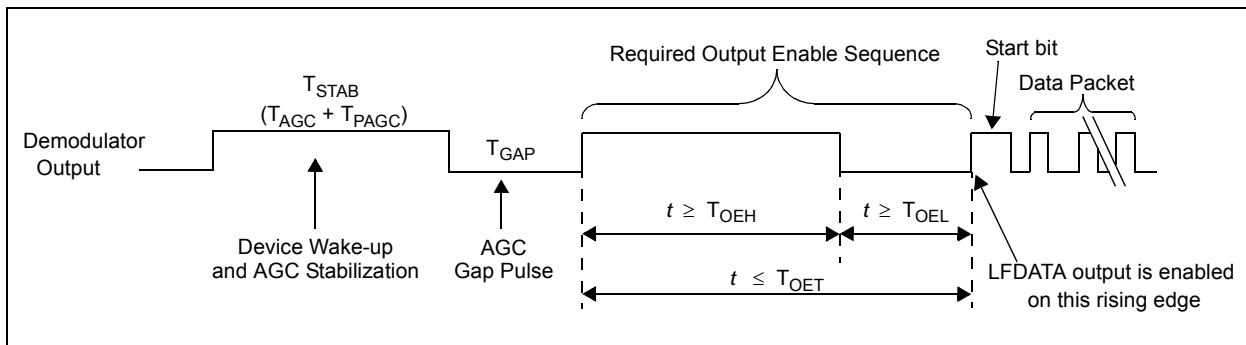

FIGURE 5-3: Output-Enable Filter Timing.

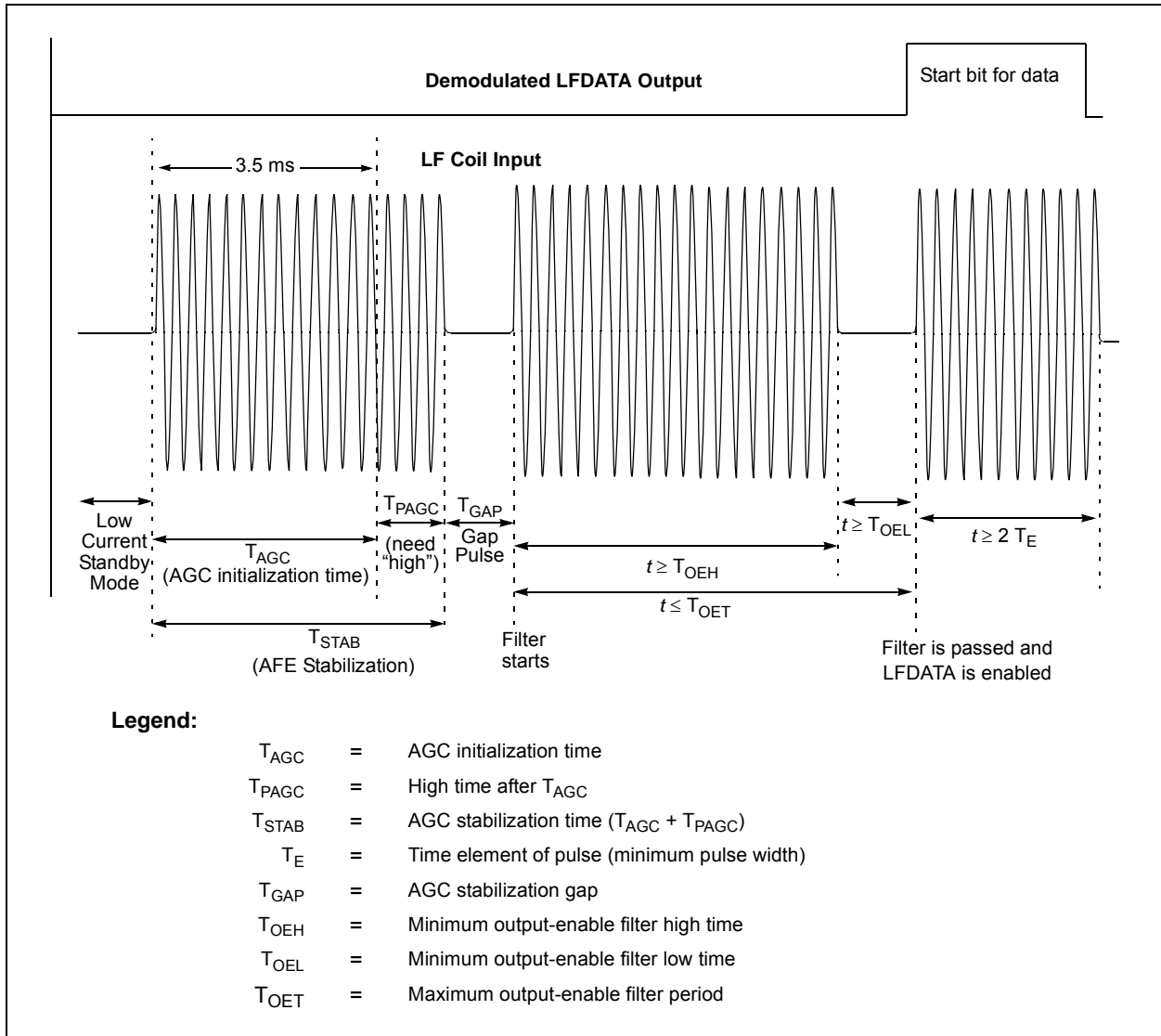

FIGURE 5-4: Output-Enable Filter Timing Example (Detailed).

MCP2030A

TABLE 5-1: OUTPUT-ENABLE FILTER TIMING

OEH <1:0>	OEL <1:0>	T _{OEH} (ms)	T _{OEL} (ms)	T _{OET} (ms)
01	00	1	1	3
01	01	1	1	3
01	10	1	2	4
01	11	1	4	6
10	00	2	1	4
10	01	2	1	4
10	10	2	2	5
10	11	2	4	8
11	00	4	1	6
11	01	4	1	6
11	10	4	2	8
11	11	4	4	10
00	xx	Filter Disabled		

Note 1: The timing values of T_{OEH} and T_{OEL} are minimum and T_{OET} is maximum at room temperature and V_{DD} = 3.0V, 32 kHz oscillator.

T_{OEH} is measured from the rising edge of the demodulator output to the first falling edge. The pulse width must fall within T_{OEH} ≤ t ≤ T_{OET}.

T_{OEL} is measured from the falling edge of the demodulator output to the rising edge of the next pulse. The pulse width must fall within T_{OEL} ≤ t ≤ T_{OET}.

T_{OET} is measured from rising edge to the next rising edge (i.e., the sum of T_{OEH} and T_{OEL}). The sum of T_{OEH} and T_{OEL} must be t ≤ T_{OET}. If the Configuration Register 0 (Register 5-1), OEH<8:7> is set to '00', then the filter is disabled. See Figure 2-28 for this case.

The filter will reset, requiring a complete new successive high and low period to enable LFDATA, under the following conditions:

- the received high is not greater than the configured minimum T_{OEH} value
- during T_{OEH}, a loss of signal for longer than 56 μs causes a filter reset
- the received low is not greater than the configured minimum T_{OEL} value
- the received sequence exceeds the maximum T_{OET} value:
 - T_{OEH} + T_{OEL} > T_{OET}
 - or T_{OEH} > T_{OET}
 - or T_{OEL} > T_{OET}
- a Soft Reset SPI command is received

If the filter resets due to a long high-time (T_{OEH} > T_{OET}), the high-pulse timer will not begin timing again until after a gap of T_E and another low-to-high transition occurs on the demodulator output.

Disabling the output-enable filter disables the T_{OEH} and T_{OEL} requirement, and the device passes all detected data. See Figure 2-28, Figure 2-29 and Figure 2-30 for examples.

When viewed from an application perspective – from the pin input – the actual output-enable filter timing must factor in the analog delays in the input path (such as demodulator charge and discharge times).

- T_{OEH} - T_{DR} + T_{DF}
- T_{OEL} + T_{DR} - T_{DF}

The output-enable filter starts immediately after T_{GAP} the gap after AGC stabilization period.

5.16 Input Sensitivity Control

The device has typical input sensitivity of 1 mV_{PP}. This means any input signal with amplitude greater than 1 mV_{PP} can be detected. The internal AGC loop regulates the detecting signal amplitude when the input level is greater than approximately 20 mV_{PP}. This signal amplitude is called “AGC-active level”. The AGC loop regulates the input voltage so that the input signal amplitude range will be kept within the linear range of the detection circuits without saturation. The AGC Active Status bit (AGCACT<5>) in Status Register 7 (Register 5-8) is set if the AGC loop regulates the input voltage.

Table 5-2 shows the input sensitivity comparison when the AGCSIG option is used. When AGCSIG option bit is set, the demodulated output is available only when the AGC loop is active (see Table 5-1). The channel input sensitivity can be reduced by setting the appropriate configuration registers. Configuration Register 3 (Register 5-4), Configuration Register 4 (Register 5-5), and Configuration Register 5 (Register 5-6) have the option to reduce each channel gain from 0 dB to approximately -30 dB.

TABLE 5-2: INPUT SENSITIVITY VS. MODULATED SIGNAL STRENGTH SETTING (AGCSIG <7>)

AGCSIG<7> (Config. Register 5)	Description	Input Sensitivity (Typical)
0	Option Disabled – Detect any input signal level (demodulated data and carrier clock).	1.0 mV _{PP}
1	Option Enabled – No output until AGC Status = 1 (i.e., V _{PEAK} ≈ 20 mV _{PP}) (demodulated data and carrier clock). • Provides the best signal to noise ratio.	20 mV _{PP}

5.17 Input Channels (Enable/Disable)

Each channel can be individually enabled or disabled by programming bits in Configuration Register 0<3:1> ([Register 5-1](#)).

The purpose of having an option to disable a particular channel is to minimize current draw by powering down as much circuitry as possible, if the channel is not needed for operation. The exact circuits disabled when an input is disabled are amplifiers, detector, full-wave rectifier, data slicer, and modulation FET. However, the RF input limiter remains active to protect the silicon from excessive antenna input voltages.

5.18 AGC Amplifier

The circuit automatically amplifies input signal voltage levels to an acceptable level for the data slicer. Fast attack and slow release by nature, the AGC tracks the carrier signal level and not the modulated data bits.

The AGC inherently tracks the strongest of the three antenna input signals. The AGC requires an AGC initialization time (T_{AGC}).

The AGC will attempt to regulate a channel's peak signal voltage into the data slicer to a desired regulated AGC voltage – reducing the input path's gain as the signal level attempts to increase above regulated AGC voltage, and allowing full amplification on signal levels below the regulated AGC voltage.

The AGC has two modes of operation:

1. During the AGC initialization time (T_{AGC}), the AGC time constant is fast, allowing a reasonably short acquisition time of the continuous input signal.
2. After T_{AGC}, the AGC switches to a slower time constant for data slicing.

Also, the AGC is frozen when the input signal envelope is low. The AGC tracks only high envelope levels.

5.19 AGC Preserve

The AGC preserve feature is used to preserve the AGC value during the AGC initialization time (T_{AGC}) and apply the value to the data slicing circuit for the following data streams instead of using a new tracking value. This feature is useful to demodulate the input signal correctly when the input has random amplitude variations at a given time period. This feature is enabled when the device receives an AGC Preserve On command and disabled if it receives an AGC Preserve Off command. Once the AGC Preserve On command is received, the device acquires a new AGC value during each AGC initialization time and preserves the value until a Soft Reset or an AGC Preserve Off command is issued. Therefore, it does not need to issue another AGC Preserve On command. An AGC Preserve Off command is needed to disable the AGC preserve feature (see [Section 5.31.2.5 “AGC Preserve On Command”](#) and [Section 5.31.2.6 “AGC Preserve Off Command”](#) for AGC Preserve commands).

MCP2030A

5.20 Soft Reset

The Soft Reset is issued in the following events:

- a) After Power-on Reset (POR),
- b) After Inactivity timer time-out,
- c) If an “Abort” occurs,
- d) After receiving SPI Soft Reset command.

The “Abort” occurs if there is no positive signal detected at the end of the AGC initialization period (T_{AGC}). The Soft Reset initializes internal circuits and brings the device into a low current Standby mode operation. The internal circuits that are initialized by the Soft Reset include:

- Output-Enable Filter
- AGC circuits
- Demodulator
- 32 kHz Internal Oscillator

The Soft Reset has no effect on the Configuration register setup, except for some of the AFE Status Register 7 bits. (Register 5-8).

The circuit initialization takes one internal clock cycle ($1/32 \text{ kHz} = 31.25 \mu\text{s}$). During the initialization, the modulation transistors between each input and LCCOM pins are turned-on to discharge any internal/external parasitic charges. The modulation transistors are turned-off immediately after the initialization time.

The Soft Reset is executed in Active mode only. It is not valid in Standby mode.

5.21 Minimum Modulation Depth Requirement for Input Signal

The device demodulates the modulated input signal if the modulation depth of the input signal is greater than the minimum requirement that is programmed in Configuration Register 5 (Register 5-6). Figure 5-5 shows the definition of the modulation depth and examples. MODMIN<6:5> of the Configuration Register 5 offer four options: 60%, 33%, 14% and 6%. The default setting is 33%.

The purpose of this feature is to enhance the demodulation integrity of the input signal. The 6% setting is the best choice for the input signal with weak modulation depth, which is typically observed near the high-voltage base station antenna and also at far-distance from the base station antenna. It gives the best demodulation sensitivity, but is very susceptible to noise spikes that can result in a bit detection error. The 60% setting can reduce the bit errors caused by noise, but gives the least demodulation sensitivity. See Table 5-3 for minimum modulation depth requirement settings.

TABLE 5-3: SETTING FOR MINIMUM MODULATION DEPTH REQUIREMENT

MODMIN Bits (Config. Register 5)		Modulation Depth
Bit 6	Bit 5	
0	0	33% (default)
0	1	60%
1	0	14%
1	1	8%

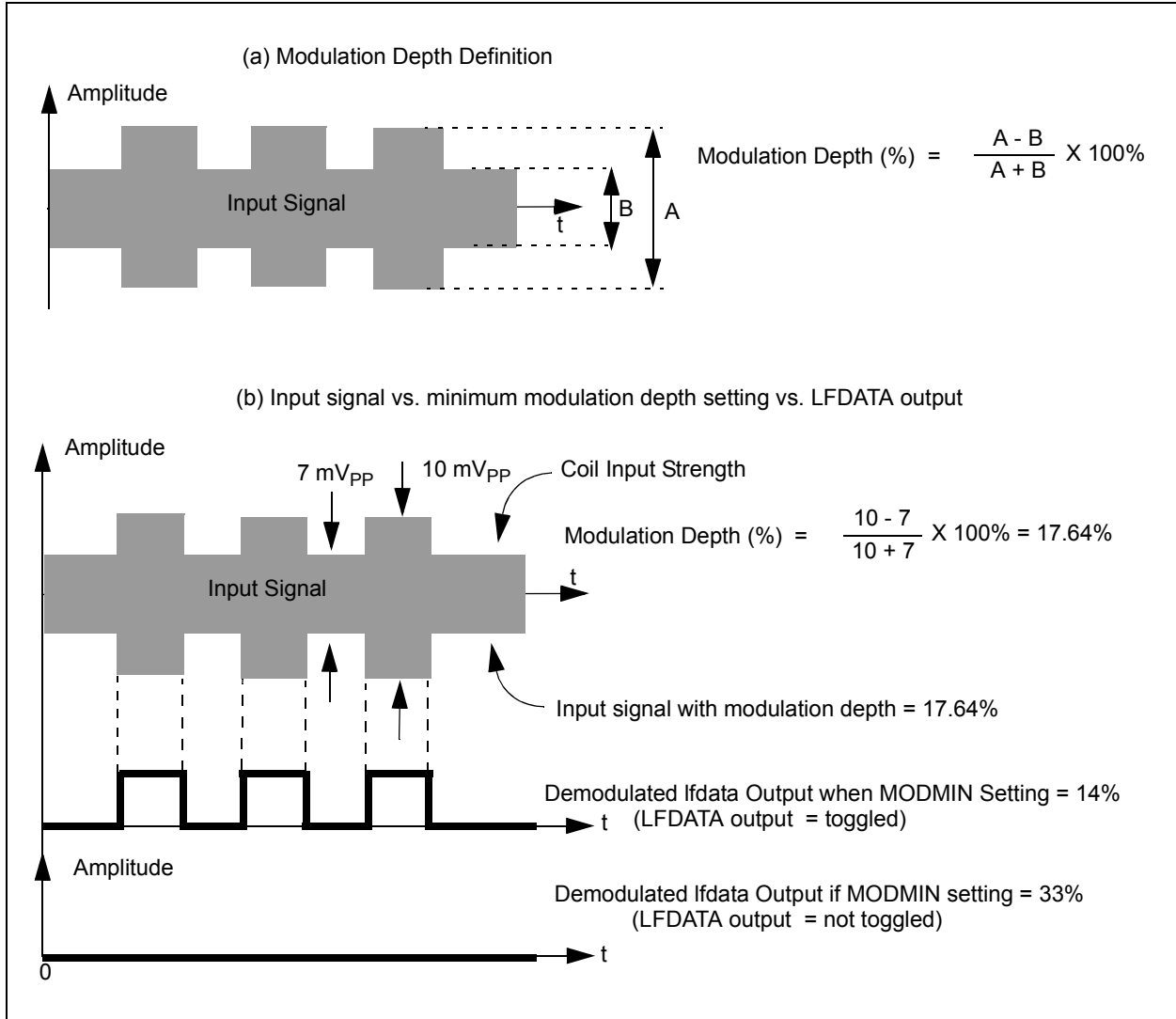

FIGURE 5-5: Modulation Depth Examples.

MCP2030A

5.22 Low-Current Sleep Mode

The device can stay at an ultra low-current mode (Sleep mode) when it receives a `Sleep` command via the SPI. All circuits including the RF Limiter (except the minimum circuitry required to retain register memory and SPI capability), will be powered down to minimize the current draw. POR or any SPI command, other than the `Sleep` command, is required to wake the device from Sleep.

5.23 Low-Current Standby Mode

The device is in Standby mode when no input signal is present on the input pins, but is powered and ready to receive any incoming signals.

5.24 Low-Current Active Mode

The device is in Low-Current Active mode when an input signal is present on any input pin and internal circuitry is switching with the received data.

5.25 Error Detection of Configuration Register Data

The Configuration registers are volatile memory. Therefore, the contents of the registers can be corrupted or cleared by any electrical incidence such as battery disconnect. To ensure data integrity, the device has an error detection mechanism using the row and column parity bits of the Configuration register memory map. Bit 0 of each register is a row parity bit that is calculated over the eight Configuration bits (from bit 1 to bit 8).

The Column Parity Register (Configuration Register 6) holds column parity bits; each bit is calculated over the respective columns (Configuration registers 0 to 5) of the Configuration bits.

The Status register is not included for the column parity bit calculation. Parity is to be odd. The parity bit set or cleared makes an odd number of set bits. The user needs to calculate the row and column parity bits using the contents of the registers and program them.

During operation, the device continuously calculates the row and column parity bits of the configuration memory map. If a parity error occurs, the device lowers the `SCLK/ALERT` pin (interrupting the microcontroller section) indicating the configuration memory has been corrupted or unloaded and needs to be reprogrammed.

At an initial condition after a Power-On-Reset, the values of the registers are all clear (default condition). Therefore, the device will issue the parity bit error by lowering the `SCLK/ALERT` pin. If the user reprograms the registers with the correct parity bits, the `SCLK/ALERT` pin will be toggled to logic high level immediately.

The parity bit errors do not change or affect any functional operation.

Table 5-4 shows an example of the register values and corresponding parity bits.

TABLE 5-4: CONFIGURATION REGISTER PARITY BIT EXAMPLE

Register Name	Bit 8	Bit 7	Bit 6	Bit 5	Bit 4	Bit 3	Bit 2	Bit 1	Bit 0 (Row Parity)
Configuration Register 0	1	0	1	0	1	0	0	0	0
Configuration Register 1	0	0	0	0	0	0	0	0	1
Configuration Register 2	0	0	0	0	0	0	0	0	1
Configuration Register 3	0	0	0	0	0	0	0	0	1
Configuration Register 4	0	0	0	0	0	0	0	0	1
Configuration Register 5	1	0	0	0	0	0	0	0	0
Configuration Register 6 (Column Parity Register)	1	1	0	1	0	1	1	1	1

5.26 Factory Calibration

The device is calibrated during probe test to reduce the device-to-device variation in standby current, internal timing and sensitivity, as well as channel-to-channel sensitivity variation.

5.27 De-Q-ing the Antenna Circuit

When the transponder is close to the base station, the transponder coil may develop coil voltage higher than V_{DE_Q} . This condition is called "near field". The device detects the strong near field signal through the AGC control, and de-Q-ing the antenna circuit to reduce the input signal amplitude.

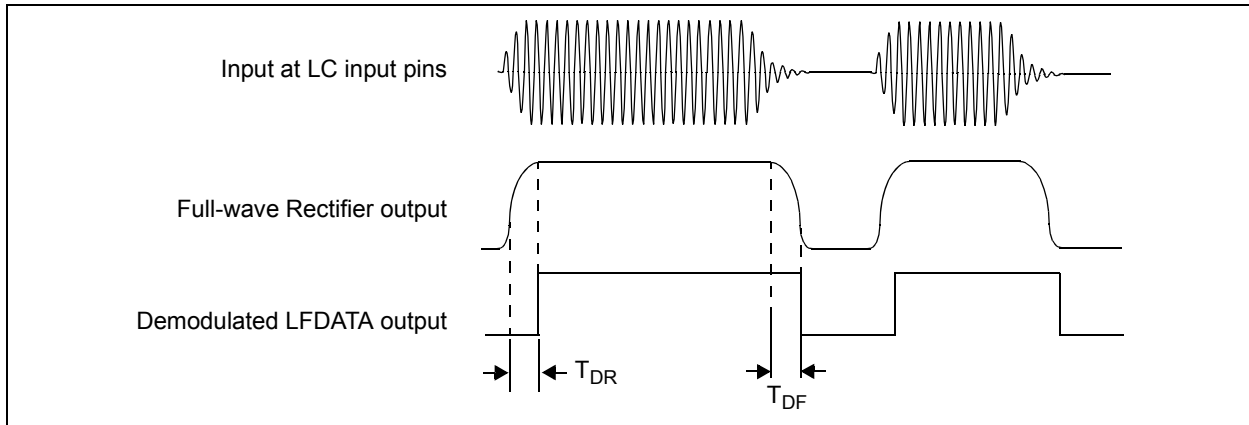

FIGURE 5-6: Demodulator Charge and Discharge.

5.28 Demodulator

The demodulator recovers the modulation data from the received signal, containing carrier plus data, by appropriate envelope detection. The demodulator has a fast rise (charge) time (T_{DR}) and a fall time (T_{DF}) appropriate to an envelope of input signal (see [Section 1.0 “Electrical Specifications”](#) for T_{DR} and T_{DF} specifications). The demodulator contains the full-wave rectifier, low-pass filter, peak detector and data slicer.

5.29 POR

This circuit remains in a Reset state until a sufficient supply voltage is applied. The Reset releases when the supply is sufficient for correct device operation, nominally V_{POR} .

The Configuration registers are all cleared on a POR. As the Configuration registers are protected by odd row and column parity, the \overline{ALERT} pin will be pulled down – indicating to the external microcontroller section that the configuration memory is cleared and requires new programming.

5.30 LFDATA Output Selection

The LFDATA output can be configured to pass the Demodulator output, Received Signal Strength Indicator (RSSI) output, or Carrier Clock (CCLK). See Configuration Register 1 ([Register 5-2](#)) for more details.

5.30.1 DEMODULATOR OUTPUT

The demodulator output is the default configuration of the output selection. This is the output of an envelope detection circuit. See [Figure 5-6](#) for the demodulator output.

For a clean data output or to save operating power, the input channels can be individually enabled or disabled. If more than one channel is enabled, the output is the sum of each output of all enabled channels. There will be no valid output if all three channels are disabled. When the demodulated output is selected, the output is available in two different conditions depending on how the options of Configuration Register 0 ([Register 5-1](#)) are set: Output-Enable Filter is disabled or enabled. See [Section 2.0 “Typical Performance Curves”](#) for various demodulated data output.

Related Configuration register bits:

- Configuration Register 1 ([Register 5-2](#)), DATOUT <8:7>:
 - bit 8 bit 7
 - 0 0: Demodulator Output
 - 0 1: Carrier Clock Output
 - 1 0: RSSI Output
 - 0 1: RSSI Output
- Configuration Register 0 ([Register 5-1](#)): all bits

MCP2030A

5.30.2 CARRIER CLOCK OUTPUT

When the carrier clock output is selected, the LFDATA output is a square pulse of the input carrier clock and available as soon as the AGC stabilization time (T_{AGC}) is completed. There are two Configuration register options for the carrier clock output: (a) clock divide-by one or (b) clock divide-by four, depending on bit DATOUT<7> of Configuration Register 2 (Register 5-3). The carrier clock output is available immediately after the AGC settling time. The Output-Enable Filter, AGCSIG, and MODMIN options are applicable for the carrier clock output in the same way as the demodulated output. The input channel can be individually enabled or disabled for the output. If more than one channel is enabled, the output is the sum of each output of all enabled channels. Therefore, the carrier clock output waveform is not as precise as when only one channel is enabled. It is recommended to enable one channel only if a precise output waveform is desired.

There will be no valid output if all three channels are disabled. See Figure 2-30 for carrier clock output examples.

Related Configuration Register Bits:

- Configuration Register 1 (Register 5-2), DATOUT <8:7>:

bit 8	bit 7	
0	0	Demodulator Output
0	1	Carrier Clock Output
1	0	RSSI Output
1	1	RSSI Output
- Configuration Register 2 (Register 5-3), CLKDIV<7>:

0	Carrier Clock/1
1	Carrier Clock/4
- Configuration Register 0 (Register 5-1): all bits are affected
- Configuration Register 5 (Register 5-6)

5.30.3 RECEIVED SIGNAL STRENGTH INDICATOR (RSSI) OUTPUT

An analog current output is available at the RSSI pin when the Received Signal Strength Indicator (RSSI) output is selected by the Configuration register. The analog current is linearly proportional to the input signal strength.

All timers in the circuit, such as inactivity timer, alarm timer, and AGC initialization time, are disabled during the RSSI mode. Therefore, the RSSI output is not affected by the AGC stabilization time, and available immediately when the RSSI option is selected. The device enters Active mode immediately when the RSSI output is selected.

When the device receives an SPI command during the RSSI output, the RSSI mode is temporarily disabled until the SPI communication is completed. It returns to the RSSI mode again after the SPI communication is completed. The RSSI mode is held until another output type is selected (CS low turns off the RSSI signal). To obtain the RSSI output for a particular input channel, or to save operating power, the input channel can be individually enabled or disabled. If more than one channel is enabled, the RSSI output is from the strongest signal channel. There will be no valid output if all three channels are disabled.

The RSSI output current is linearly proportional to the input signal strength. There are variations from channel to channel and device to device. The linearity (ILR_{RSSI}) of the RSSI output current is tested by sampling the outputs for three input points: 37 mV_{PP}, 100 mV_{PP}, and 370 mV_{PP}. The RSSI output current for 100 mV_{PP} of input signal is compared with the expected output current obtained from the line that is connecting the two endpoints (37 mV_{PP} and 370 mV_{PP}). Equation 5-1 and Figure 5-7 show the details for the RSSI linearity specification.

EQUATION 5-1: RSSI LINEARITY SPECIFICATION

$$ILR_{RSSI}(\%) = \frac{\text{Deviation at } 100 \text{ mV}_{PP} \text{ of Input Signal}}{I_{RSSI} \text{ for } 370 \text{ mV}_{PP} \text{ of Input Signal}} \times 100\%$$

where,

Deviation at 100 mV_{PP} of Input Signal = $[I_{RSSI} \text{ measured} - I_{RSSI} \text{ expected}]$ at 100 mV_{PP} of input signal.

$I_{RSSI} \text{ expected}$ = RSSI current obtained from the line that is connecting two endpoints (RSSI output currents for 37 mV_{PP} and 370 mV_{PP} of inputs).

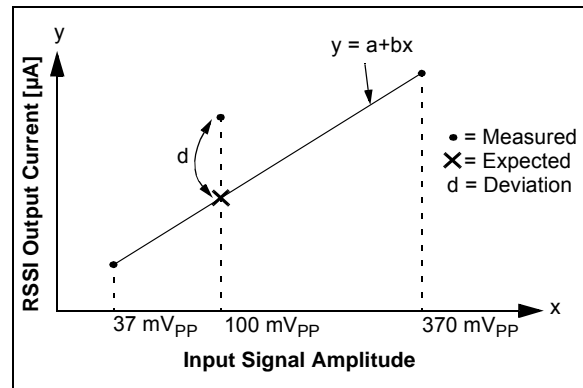

FIGURE 5-7: RSSI Linearity Test Example

Related Configuration Register Bits:

- Configuration Register 1 (Register 5-2), DATOUT<8:7>:

bit 8	bit 7
0	0: Demodulated Output
0	1: Carrier Clock Output
1	0: RSSI Output
1	1: RSSI Output
- Configuration Register 2 (Register 5-3), RSSIFET<8>:

0: Pull-Down MOSFET off
1: Pull-Down MOSFET on.

Note: The pull-down MOSFET option is valid only when the RSSI output is selected. The MOSFET is not controllable by users when demodulated or carrier clock output option is selected.

- Configuration Register 0 (Register 5-1): all bits are affected.

5.30.3.1 ANALOG-TO-DIGITAL DATA CONVERSION OF RSSI SIGNAL

The RSSI output is an analog current. It needs an external analog-to-digital (ADC) data conversion device for digitized output. The ADC data conversion can be accomplished by using a stand-alone external ADC device, an external MCU that has internal ADC features, or an external MCU that has no ADC features but instead uses firmware. The RSSIFET is used to discharge any external charge on the LFDATA pin in the RSSI Output mode. The MOSFET can be turned on or off with bit RSSIFET<8> of Configuration Register 2 (Register 5-3). When it is turned on, the internal MOSFET provides a discharge path for the external capacitor that is connected at the LFDATA pin. This MOSFET option is valid only if RSSI output is selected and not controllable by users for demodulated or carrier clock output options.

See separate application notes for various external ADC implementation methods for this device.

See Figure 5-8 for RSSI output path.

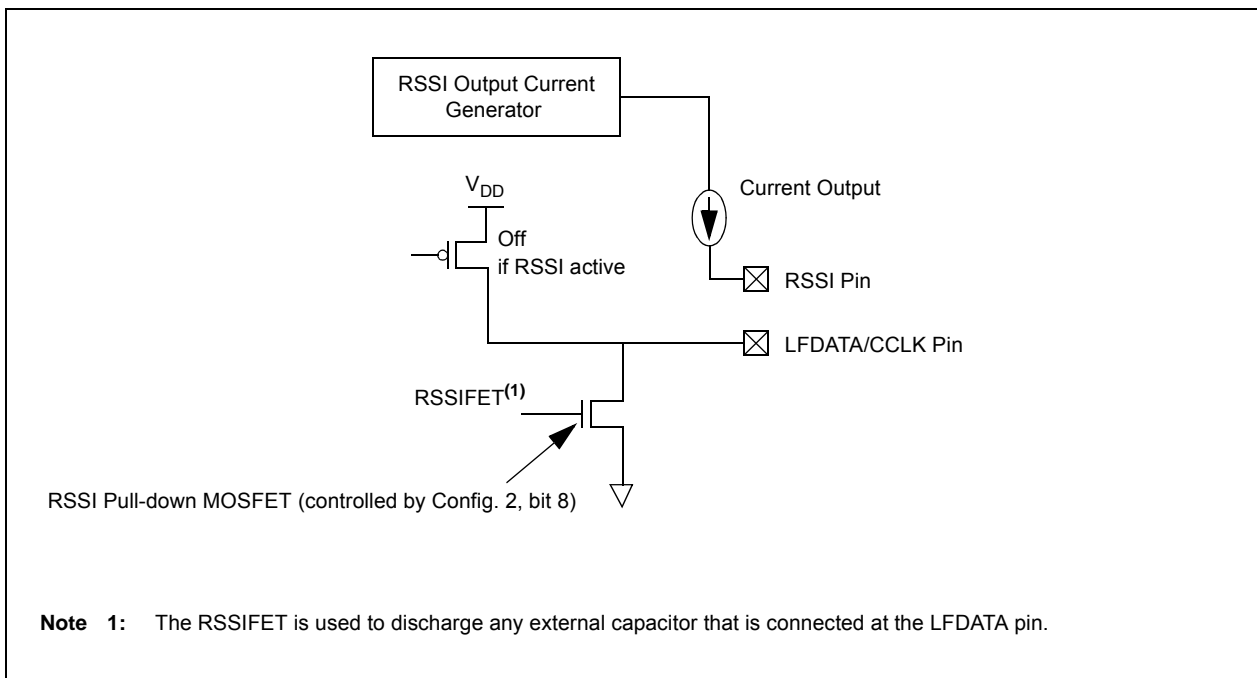

FIGURE 5-8: RSSI Output Path.

MCP2030A

5.31 Configuration Registers

5.31.1 SPI COMMUNICATION

The SPI communication is used to read from or write to the Configuration registers and to send command-only messages. Three pins are used for SPI communication: \overline{CS} , SCLK/ALERT, and LFDATA/RSSI/CCLK/SDIO. Figure 5-9, Figure 5-10 and Figure 5-11 show examples of the SPI communication sequences.

When these pins are connected to the external MCU I/O pins, the following are needed:

\overline{CS}

- Pin is permanently an input with an internal pull-up

SCLK/ALERT

- Pin is an open collector output when \overline{CS} is high. An internal pull-up resistor exists to ensure no spurious SPI communication between powering and the MCU configuring its pins. This pin becomes the SPI clock input when \overline{CS} is low

LFDATA/CCLK/SDIO

- Pin is a digital output (LFDATA) so long as \overline{CS} is high. During SPI communication, the pin is the SPI data input (SDI) unless performing a register Read, where it will be the SPI data output (SDO).

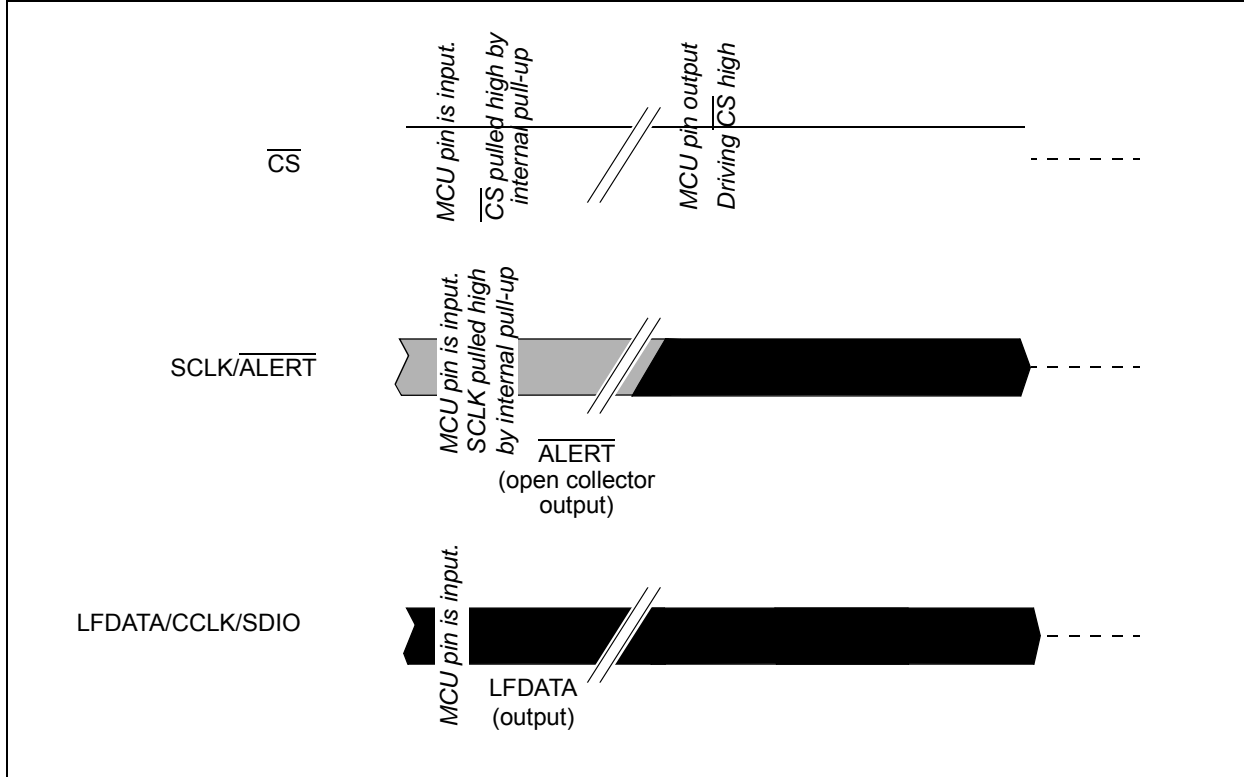

FIGURE 5-9: Power-Up Sequence.

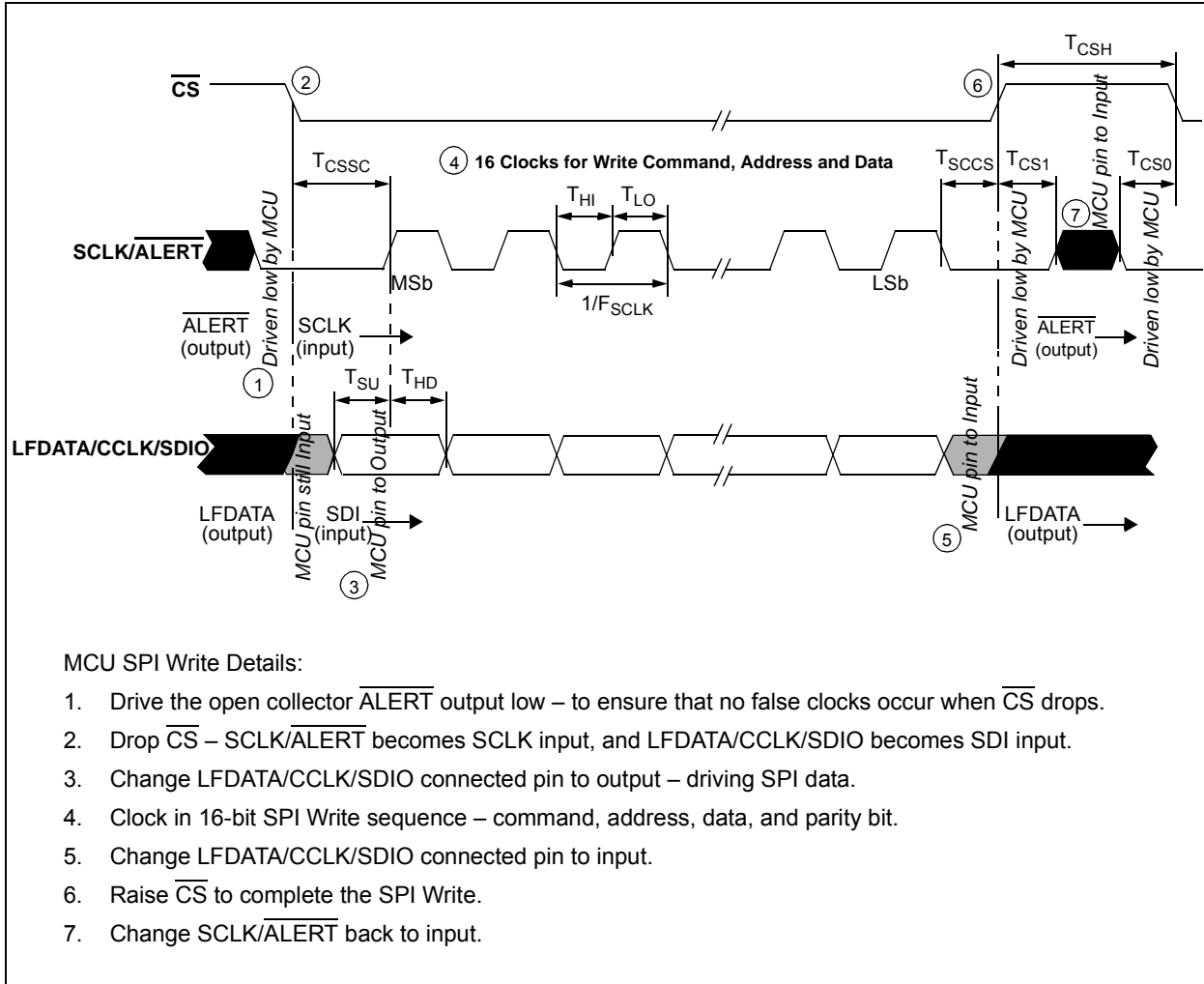
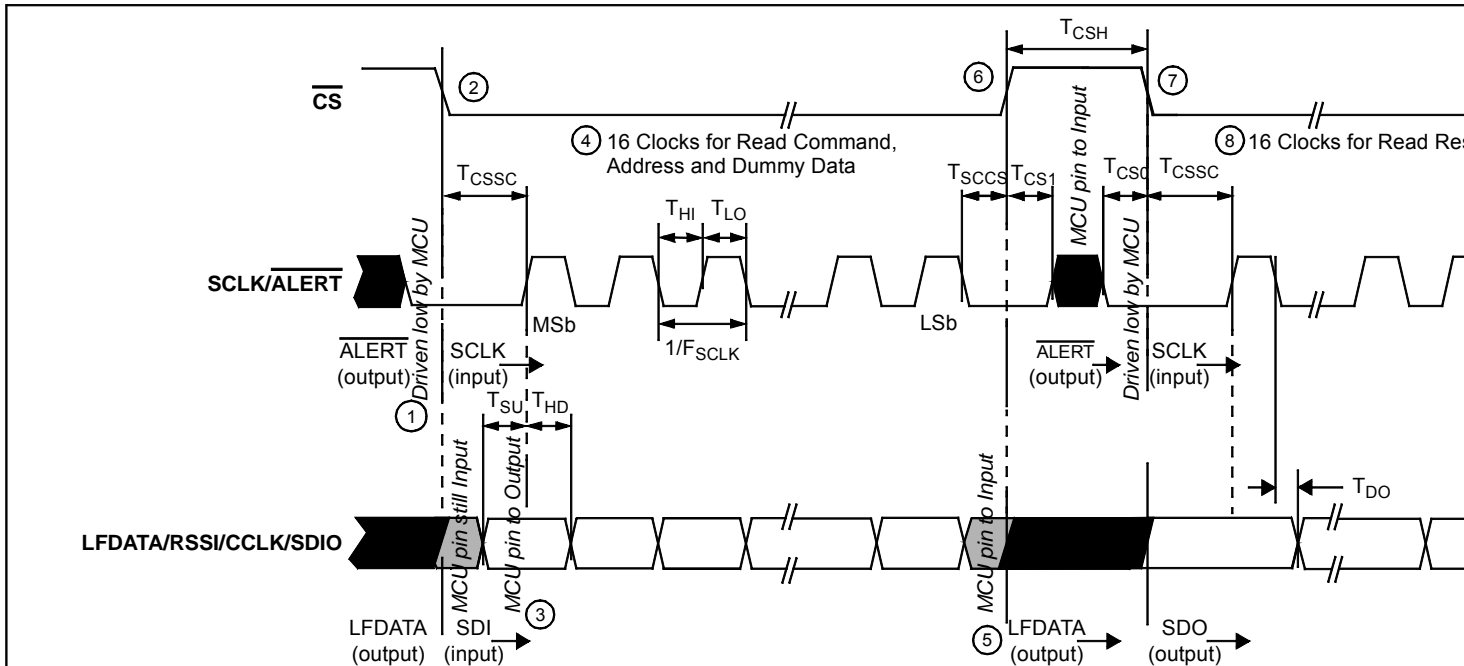

FIGURE 5-10: SPI Write Sequence.



MCU SPI Read Details:

1. Drive the open collector $\overline{\text{ALERT}}$ output low – to ensure that no false clocks occur when $\overline{\text{CS}}$ drops.
2. Drop $\overline{\text{CS}}$ – SCLK/ $\overline{\text{ALERT}}$ becomes SCLK input, and LFDATA/CCLK/SDIO becomes SDI input.
3. Change LFDATA/CCLK/SDIO connected pin to output – driving SPI data.
4. Clock in 16-bit SPI Read sequence – command, address, and dummy data.
5. Change LFDATA/CCLK/SDIO connected pin to input.
6. Raise $\overline{\text{CS}}$ to complete the SPI Read entry of command and address.
7. Drop $\overline{\text{CS}}$ – AFE SCLK/ $\overline{\text{ALERT}}$ becomes SCLK input, and LFDATA/CCLK/SDIO becomes SDO output.
8. Clock out 16-bit SPI Read result – first seven bits clocked-out are dummy bits, the next eight bits are the Configuration register data, and the last bit is the Configuration register row parity bit.
9. Raise $\overline{\text{CS}}$ to complete the SPI Read.
10. Change SCLK/ $\overline{\text{ALERT}}$ back to input.

Note: The T_{CSH} is considered as one clock. Therefore, the Configuration register data appears at 6th clock after T_{CSH} .

FIGURE 5-11: SPI Read Sequence.

5.31.2 COMMAND DECODER/CONTROLLER

The circuit executes 8 SPI commands from the external MCU. The command structure is:

Command (3 bits) + Configuration Address (4 bits) + Data Byte and Row Parity Bit with the Most Significant bit first.

Table 5-5 shows the available SPI commands.

The device operates in SPI mode 0,0. In mode 0,0 the clock idles in the low state (Figure 5-12). SDI data is loaded into the device on the rising edge of SCLK, and SDO data is clocked out on the falling edge of SCLK. There must be multiples of 16 clocks (SCLK) while CS is low or commands will abort.

TABLE 5-5: SPI COMMANDS

Command	Address	Data	Row Parity	Description
Command only – Address and Data are “Don’t Care”, but need to be clocked in regardless.				
000	XXXX	XXXX XXXX	X	Clamp on – enable modulation circuit
001	XXXX	XXXX XXXX	X	Clamp off – disable modulation circuit
010	XXXX	XXXX XXXX	X	Enter Sleep mode (any other command wakes the AFE)
011	XXXX	XXXX XXXX	X	AGC Preserve On – to temporarily preserve the current AGC level
100	XXXX	XXXX XXXX	X	AGC Preserve Off – AGC again tracks strongest input signal
101	XXXX	XXXX XXXX	X	Soft Reset – resets various circuit blocks
Read Command – Data will be read from the specified register address.				
110	0000	Config Byte 0	P	General – options that may change during normal operation
	0001	Config Byte 1	P	LCX antenna tuning and LFDATA output format
	0010	Config Byte 2	P	LCY antenna tuning
	0011	Config Byte 3	P	LCZ antenna tuning
	0100	Config Byte 4	P	LCX and LCY sensitivity reduction
	0101	Config Byte 5	P	LCZ sensitivity reduction and modulation depth
	0110	Column Parity	P	Column parity byte for Config Byte 0 -> Config Byte 5
	0111	Status	X	Status – parity error, which input is active, etc.
Write Command – Data will be written to the specified register address.				
111	0000	Config Byte 0	P	Output-enable filter, channel enable/disable, etc.
	0001	Config Byte 1	P	LCX antenna tuning and LFDATA output type
	0010	Config Byte 2	P	LCY antenna tuning
	0011	Config Byte 3	P	LCZ antenna tuning
	0100	Config Byte 4	P	LCX and LCY sensitivity reduction
	0101	Config Byte 5	P	LCZ sensitivity reduction and modulation depth
	0110	Column Parity	P	Column parity byte for Config Byte 0 -> Config Byte 5
	0111	Not Used	X	Register is readable, but not writable

Note: ‘P’ denotes the row parity bit (odd parity) for the respective data byte.

MCP2030A

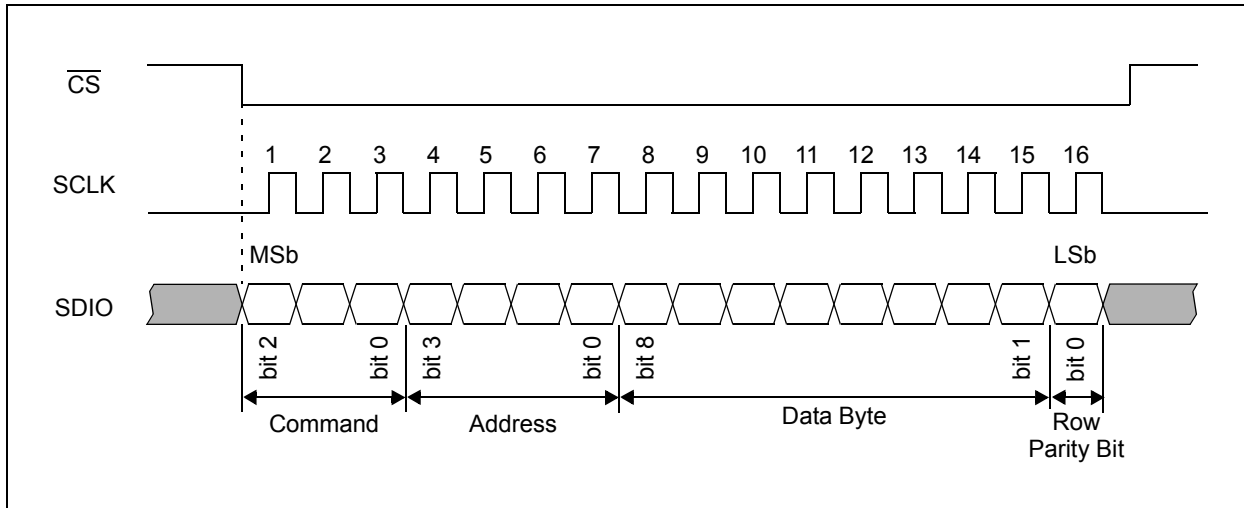

FIGURE 5-12: Detailed SPI Timing (AFE).

5.31.2.1 Clamp On Command

This command results in activating (turning on) the modulation transistors of all enabled channels; channels enabled in Configuration Register 0 (Register 5-1).

5.31.2.2 Clamp Off Command

This command results in deactivating (turning off) the modulation transistors of all channels.

5.31.2.3 Sleep Command

This command places the device in Sleep mode – minimizing current draw by disabling all but the essential circuitry. Any other command wakes the device from Sleep (e.g., Clamp Off command).

5.31.2.4 Soft Reset Command

The device issues a Soft Reset when it receives an external Soft Reset command. The external Soft Reset command is typically used to end an SPI communication sequence or to initialize the device for the next signal detection sequence, etc. See Section 5.20 “Soft Reset” for more details on Soft Reset.

If a Soft Reset command is sent during a “Clamp-on” condition, the device still keeps the “Clamp-on” condition after the Soft Reset execution. The Soft Reset is executed in Active mode only, not in Standby mode. The SPI Soft Reset command is ignored if the device is not in Active mode.

5.31.2.5 AGC Preserve On Command

The AGC Preserve On command results in preserving the AGC level during each AGC initialization time and applying the value to the data slicing circuit for the following data stream, instead of using a new tracking value

. The preserved AGC value is reset by a Soft Reset, and a new AGC value is acquired and preserved when it starts a new AGC initialization time. This feature is disabled by an AGC Preserve Off command (see Section 5.19 “AGC Preserve”).

5.31.2.6 AGC Preserve Off Command

This command disables the AGC preserve feature and returns to the normal AGC tracking mode, fast tracking during AGC settling time and slow tracking after that (see Section 5.19 “AGC Preserve”).

5.31.3 READ/WRITE COMMANDS FOR CONFIGURATION REGISTERS

The device includes eight Configuration registers, including a Column Parity register and Status register. All registers are readable and writable via SPI, except the Status register, which is read-only. Bit 0 of each register is a row parity bit (except for Status Register 7) that makes the register contents an odd number.

TABLE 5-6: CONFIGURATION REGISTERS SUMMARY

Register Name	Bit 8	Bit 7	Bit 6	Bit 5	Bit 4	Bit 3	Bit 2	Bit 1	Bit 0
Configuration Register 0	OEH		OEL		ALRTIND	LCZEN	LCYEN	LCXEN	R0PAR
Configuration Register 1	DATOUT				Channel X Tuning Capacitor				R1PAR
Configuration Register 2	RSSIFET	CLKDIV	Channel Y Tuning Capacitor				R2PAR		
Configuration Register 3	Unimplemented		Channel Z Tuning Capacitor				R3PAR		
Configuration Register 4	Channel X Sensitivity Control				Channel Y Sensitivity Control				R4PAR
Configuration Register 5	AUTOCHSEL	AGCSIG	MODMIN	MODMIN	Channel Z Sensitivity Control				R5PAR
Column Parity Register 6	Column Parity Bits								R6PAR
Status Register 7	Active Channel Indicators			AGCACT	Wake-up Channel Indicators			ALARM	PEI

REGISTER 5-1: CONFIGURATION REGISTER 0 (ADDRESS: 0000)

	R/W-0	R/W-0	R/W-0	R/W-0	R/W-0	R/W-0	R/W-0	R/W-0	R/W-0
OEH1	OEH0	OEL1	OEL0	ALRTIND	LCZEN	LCYEN	LCXEN	R0PAR	
bit 8									bit 0

Legend:	Legend:		
	R = Readable bit	W = Writable bit	U = Unimplemented bit, read as '0'
	-n = Value at POR	'1' = Bit is set	'0' = Bit is cleared x = Bit is unknown

- bit 8-7 **OEH<1:0>**: Output-Enable Filter High Time (T_{OEH}) bit
 00 = Output-Enable Filter disabled (no wake-up sequence required, passes all signal to LFDATA)
 01 = 1 ms
 10 = 2 ms
 11 = 4 ms
- bit 6-5 **OEL<1:0>**: Output-Enable Filter Low Time (T_{OEL}) bit
 00 = 1 ms
 01 = 1 ms
 10 = 2 ms
 11 = 4 ms
- bit 4 **ALRTIND**: ALERT bit, output triggered by:
 1 = Parity error and/or expired Alarm timer (receiving noise, see [Section 5.14.3 "Alarm Timer"](#))
 0 = Parity error
- bit 3 **LCZEN**: LCZ Enable bit
 1 = Disabled
 0 = Enabled
- bit 2 **LCYEN**: LCY Enable bit
 1 = Disabled
 0 = Enabled
- bit 1 **LCXEN**: LCX Enable bit
 1 = Disabled
 0 = Enabled
- bit 0 **R0PAR**: Register 0 Parity bit – set/cleared so the 9-bit register contains odd parity – an odd number of set bits

MCP2030A

REGISTER 5-2: CONFIGURATION REGISTER 1 (ADDRESS: 0001)

R/W-0	R/W-0	R/W-0	R/W-0	R/W-0	R/W-0	R/W-0	R/W-0	R/W-0
DATOUT1	DATOUT0	LCXTUN5	LCXTUN4	LCXTUN3	LCXTUN2	LCXTUN1	LCXTUN0	R1PAR
bit 8								bit 0

Legend:								
R = Readable bit			W = Writable bit			U = Unimplemented bit, read as '0'		
-n = Value at POR			'1' = Bit is set			'0' = Bit is cleared		
						x = Bit is unknown		

- bit 8-7 **DATOUT<1:0>**: LFDATA Output type bit
 00 = Demodulated output
 01 = Carrier clock output
 10 = RSSI output
 11 = RSSI output
- bit 6-1 **LCXTUN<5:0>**: LCX Tuning Capacitance bit
 000000 = +0 pF (Default)
 111111 = +63 pF
- bit 0 **R1PAR**: Register 1 Parity Bit – set/cleared so the 9-bit register contains odd parity – an odd number of set bits

REGISTER 5-3: CONFIGURATION REGISTER 2 (ADDRESS: 0010)

R/W-0	R/W-0	R/W-0	R/W-0	R/W-0	R/W-0	R/W-0	R/W-0	R/W-0
RSSIFET	CLKDIV	LCYTUN5	LCYTUN4	LCYTUN3	LCYTUN2	LCYTUN1	LCYTUN0	R2PAR
bit 8								bit 0

Legend:								
R = Readable bit			W = Writable bit			U = Unimplemented bit, read as '0'		
-n = Value at POR			'1' = Bit is set			'0' = Bit is cleared		
						x = Bit is unknown		

- bit 8 **RSSIFET**: Pull-down MOSFET on LFDATA pad bit (controllable by user in the RSSI mode only)
 1 = Pull-down RSSI MOSFET on
 0 = Pull-down RSSI MOSFET off
- bit 7 **CLKDIV**: Carrier Clock Divide-by bit
 1 = Carrier clock/4
 0 = Carrier clock/1
- bit 6-1 **LCYTUN<5:0>**: LCY Tuning Capacitance bit
 000000 = +0 pF (Default)
 :
 111111 = +63 pF
- bit 0 **R2PAR**: Register 2 Parity bit – set/cleared so the 9-bit register contains odd parity – an odd number of set bits

REGISTER 5-4: CONFIGURATION REGISTER 3 (ADDRESS: 0011)

R/W-0	R/W-0	R/W-0	R/W-0	R/W-0	R/W-0	R/W-0	R/W-0	R/W-0
—	—	LCZTUN5	LCZTUN4	LCZTUN3	LCZTUN2	LCZTUN1	LCZTUN0	R3PAR
bit 8								bit 0

Legend:

R = Readable bit W = Writable bit U = Unimplemented bit, read as '0'
 -n = Value at POR '1' = Bit is set '0' = Bit is cleared x = Bit is unknown

bit 8-7 **Unimplemented:** Read as '0'

bit 6-1 **LCZTUN<5:0>:** LCZ Tuning Capacitance bit
 000000 = +0 pF (Default)
 111111 = +63 pF

bit 0 **R3PAR:** Register 3 Parity Bit – set/cleared so the 9-bit register contains odd parity – an odd number of set bits

REGISTER 5-5: CONFIGURATION REGISTER 4 (ADDRESS: 0100)

R/W-0	R/W-0	R/W-0	R/W-0	R/W-0	R/W-0	R/W-0	R/W-0	R/W-0
LCXSEN3	LCXSEN2	LCXSEN1	LCXSEN0	LCYSEN3	LCYSEN2	LCYSEN1	LCYSEN0	R4PAR
bit 8								bit 0

Legend:

R = Readable bit W = Writable bit U = Unimplemented bit, read as '0'
 -n = Value at POR '1' = Bit is set '0' = Bit is cleared x = Bit is unknown

bit 8-5 **LCXSEN<3:0>⁽¹⁾:** Typical LCX Sensitivity Reduction bit
 0000 = -0 dB (Default)
 0001 = -2 dB
 0010 = -4 dB
 0011 = -6 dB
 0100 = -8 dB
 0101 = -10 dB
 0110 = -12 dB
 0111 = -14 dB
 1000 = -16 dB
 1001 = -18 dB
 1010 = -20 dB
 1011 = -22 dB
 1100 = -24 dB
 1101 = -26 dB
 1110 = -28 dB
 1111 = -30 dB

bit 4-1 **LCYSEN<3:0>⁽¹⁾:** Typical LCY Sensitivity Reduction bit
 0000 = -0 dB (Default)
 1111 = -30 dB

bit 0 **R4PAR:** Register 4 Parity bit – set/cleared so the 9-bit register contains odd parity – an odd number of set bits

Note 1: Assured monotonic increment (or decrement) by design.

MCP2030A

REGISTER 5-6: CONFIGURATION REGISTER 5 (ADDRESS: 0101)

R/W-0	R/W-0	R/W-0	R/W-0	R/W-0	R/W-0	R/W-0	R/W-0	R/W-0
AUTOCHSEL	AGCSIG	MODMIN1	MODMIN0	LCZSEN3	LCZSEN2	LCZSEN1	LCZSEN0	R5PAR
bit 8								bit 0

Legend:			
R = Readable bit	W = Writable bit	U = Unimplemented bit, read as '0'	
-n = Value at POR	'1' = Bit is set	'0' = Bit is cleared	x = Bit is unknown

- bit 8 **AUTOCHSEL**: Auto-Channel Select bit
 1 = Enabled – Device selects channel(s) that has demodulator output “high” at the end of T_{AGC}; or otherwise, blocks the channel(s).
 0 = Disabled – Device follows channel enable/disable bits defined in Register 0
- bit 7 **AGCSIG**: Demodulator Output Enable bit, after the AGC loop is active
 1 = Enabled – No output until AGC is regulating at approximately 20 mV_{PP} at input pins. The AGC Active Status bit is set when the AGC begins regulating.
 0 = Disabled – The device passes signal of any level it is capable of detecting
- bit 6-5 **MODMIN<1:0>**: Minimum Modulation Depth bit
 00 = 33%
 01 = 60%
 10 = 14%
 11 = 8%
- bit 4-1 **LCZSEN<3:0>⁽¹⁾**: LCZ Sensitivity Reduction bit
 0000 = -0 dB (Default)
 1111 = -30 dB
- bit 0 **R5PAR**: Register 5 Parity bit – set/cleared so the 9-bit register contains odd parity – an odd number of set bits

Note 1: Assured monotonic increment (or decrement) by design.

REGISTER 5-7: COLUMN PARITY REGISTER 6 (ADDRESS: 0110)

R/W-0	R/W-0	R/W-0	R/W-0	R/W-0	R/W-0	R/W-0	R/W-0	R/W-0
COLPAR7	COLPAR6	COLPAR5	COLPAR4	COLPAR3	COLPAR2	COLPAR1	COLPAR0	R6PAR
bit 8								bit 0

Legend:

R = Readable bit	W = Writable bit	U = Unimplemented bit, read as '0'
-n = Value at POR	'1' = Bit is set	'0' = Bit is cleared x = Bit is unknown

- bit 8 **COLPAR7:** Set/Cleared so that this 8th parity bit + the sum of the Config register row parity bits contain an odd number of set bits.
- bit 7 **COLPAR6:** Set/Cleared such that this 7th parity bit + the sum of the 7th bits in Config registers 0 through 5 contain an odd number of set bits.
- bit 6 **COLPAR5:** Set/Cleared such that this 6th parity bit + the sum of the 6th bits in Config registers 0 through 5 contain an odd number of set bits.
- bit 5 **COLPAR4:** Set/Cleared such that this 5th parity bit + the sum of the 5th bits in Config registers 0 through 5 contain an odd number of set bits.
- bit 4 **COLPAR3:** Set/Cleared such that this 4th parity bit + the sum of the 4th bits in Config registers 0 through 5 contain an odd number of set bits.
- bit 3 **COLPAR2:** Set/Cleared such that this 3rd parity bit + the sum of the 3rd bits in Config registers 0 through 5 contain an odd number of set bits.
- bit 2 **COLPAR1:** Set/Cleared such that this 2nd parity bit + the sum of the 2nd bits in Config registers 0 through 5 contain an odd number of set bits.
- bit 1 **COLPAR0:** Set/Cleared such that this 1st parity bit + the sum of the 1st bits in Config registers 0 through 5 contain an odd number of set bits.
- bit 0 **R6PAR:** Register 6 Parity bit – set/cleared so the 9-bit register contains odd parity – an odd number of set bits

MCP2030A

REGISTER 5-8: STATUS REGISTER 7 (ADDRESS: 0111)

R/W-0	R/W-0	R/W-0	R/W-0	R/W-0	R/W-0	R/W-0	R/W-0	R/W-0
CHZACT	CHYACT	CHXACT	AGCACT	WAKEZ	WAKEY	WAKEX	ALARM	PEI
bit 8								bit 0

Legend:			
R = Readable bit	W = Writable bit	U = Unimplemented bit, read as '0'	
-n = Value at POR	'1' = Bit is set	'0' = Bit is cleared	x = Bit is unknown

- bit 8 **CHZACT:** Channel Z Active⁽¹⁾ bit (cleared via Soft Reset)
 1 = Channel Z is passing data after T_{AGC}
 0 = Channel Z is not passing data after T_{AGC}
- bit 7 **CHYACT:** Channel Y Active⁽¹⁾ bit (cleared via Soft Reset)
 1 = Channel Y is passing data after T_{AGC}
 0 = Channel Y is not passing data after T_{AGC}
- bit 6 **CHXACT:** Channel X Active⁽¹⁾ bit (cleared via Soft Reset)
 1 = Channel X is passing data after T_{AGC}
 0 = Channel X is not passing data after T_{AGC}
- bit 5 **AGCACT:** AGC Active Status bit (real time, cleared via Soft Reset)
 1 = AGC is active (Input signal is strong). AGC is active when input signal level is approximately > 20 mV_{PP} range.
 0 = AGC is inactive (Input signal is weak)
- bit 4 **WAKEZ:** Wake-up Channel Z Indicator Status bit (cleared via Soft Reset)
 1 = Channel Z caused a device wake-up (passed ± 64 clock counter)
 0 = Channel Z did not cause a device wake-up
- bit 3 **WAKEY:** Wake-up Channel Y Indicator Status bit (cleared via Soft Reset)
 1 = Channel Y caused a device wake-up (passed ± 64 clock counter)
 0 = Channel Y did not cause a device wake-up
- bit 2 **WAKEX:** Wake-up Channel X Indicator Status bit (cleared via Soft Reset)
 1 = Channel X caused a device wake-up (passed ± 64 clock counter)
 0 = Channel X did not cause a device wake-up
- bit 1 **ALARM:** Indicates whether an Alarm Timer time-out has occurred (cleared via read "Status Register command")
 1 = The Alarm Timer time-out has occurred. It may cause the $\overline{\text{ALERT}}$ output to go low depending on the state of bit 4 of the Configuration register 0
 0 = The Alarm timer is not timed out
- bit 0 **PEI:** Parity Error Indicator bit – indicates whether a Configuration register parity error has occurred (real time)
 1 = A parity error has occurred and caused the $\overline{\text{ALERT}}$ output to go low
 0 = A parity error has not occurred

Note 1: Bit is high whenever channel is passing data. Bit is low in Standby mode.

See [Table 5-7](#) for the bit conditions of the AFE Status register after various SPI commands and the AFE POR.

**TABLE 5-7: STATUS REGISTER BIT CONDITION
(AFTER POR AND VARIOUS SPI COMMANDS)**

Condition	Bit 8	Bit 7	Bit 6	Bit 5	Bit 4	Bit 3	Bit 2	Bit 1	Bit 0
	CHZACT	CHYACT	CHXACT	AGCACT	WAKEZ	WAKEY	WAKEX	ALARM	PEI
POR	0	0	0	0	0	0	0	0	1
Read Command (STATUS Register only)	u	u	u	u	u	u	u	0	u
Sleep Command	u	u	u	u	u	u	u	u	u
Soft Reset Executed ⁽¹⁾	0	0	0	0	0	0	0	u	u

Legend: u = unchanged

Note 1: See [Section 5.20 “Soft Reset”](#) and [Section 5.31.2.4 “Soft Reset Command”](#) for the condition of Soft Reset execution.

MCP2030A

6.0 PACKAGING INFORMATION

6.1 Package Marking Information

14-Lead PDIP

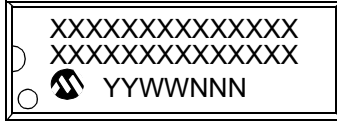

Example

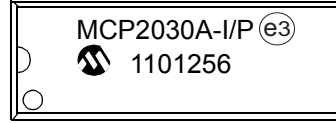

14-Lead SOIC



Example

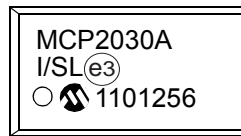

14-Lead TSSOP

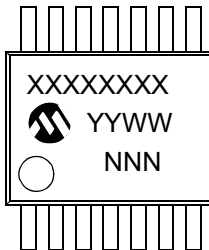

Example

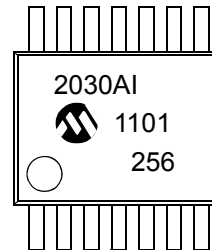

Legend:	XX...X	Customer-specific information
	Y	Year code (last digit of calendar year)
	YY	Year code (last 2 digits of calendar year)
	WW	Week code (week of January 1 is week '01')
	NNN	Alphanumeric traceability code
	(e3)	Pb-free JEDEC designator for Matte Tin (Sn)
	*	This package is Pb-free. The Pb-free JEDEC designator (e3) can be found on the outer packaging for this package.

Note: In the event the full Microchip part number cannot be marked on one line, it will be carried over to the next line, thus limiting the number of available characters for customer-specific information.

14-Lead Plastic Dual In-Line (P) – 300 mil Body [PDIP]

Note: For the most current package drawings, please see the Microchip Packaging Specification located at <http://www.microchip.com/packaging>

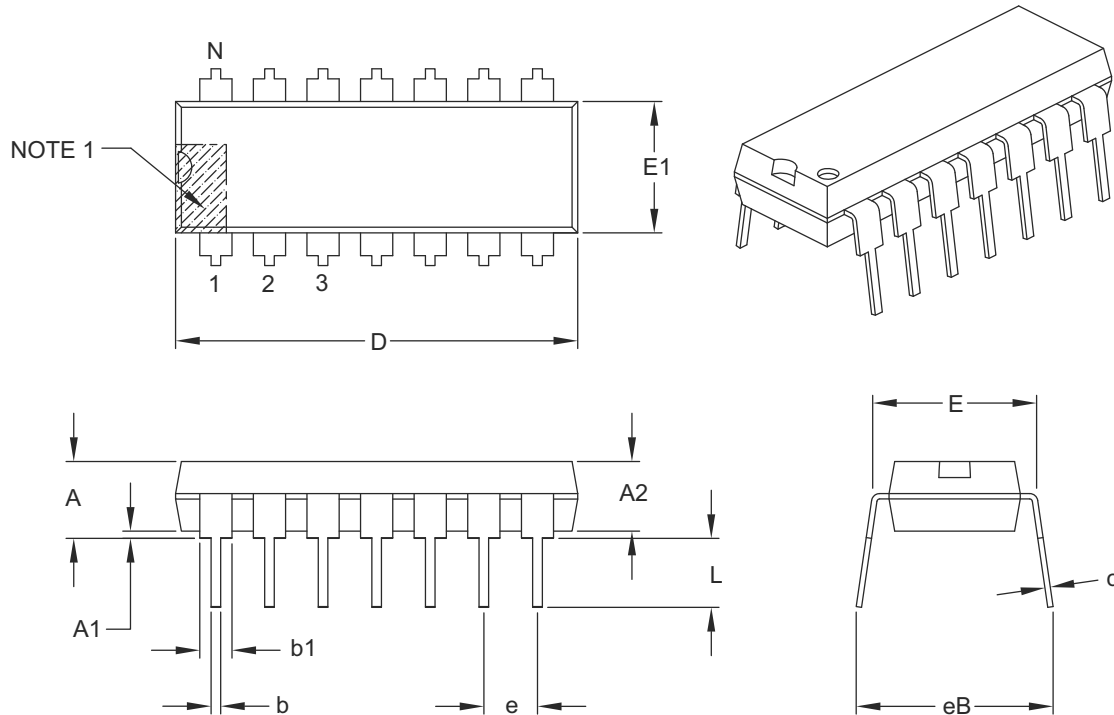

Dimension Limits	Units	INCHES		
		MIN	NOM	MAX
Number of Pins	N	14		
Pitch	e	.100 BSC		
Top to Seating Plane	A	–	–	.210
Molded Package Thickness	A2	.115	.130	.195
Base to Seating Plane	A1	.015	–	–
Shoulder to Shoulder Width	E	.290	.310	.325
Molded Package Width	E1	.240	.250	.280
Overall Length	D	.735	.750	.775
Tip to Seating Plane	L	.115	.130	.150
Lead Thickness	c	.008	.010	.015
Upper Lead Width	b1	.045	.060	.070
Lower Lead Width	b	.014	.018	.022
Overall Row Spacing §	eB	–	–	.430

Notes:

- Pin 1 visual index feature may vary, but must be located with the hatched area.
- § Significant Characteristic.
- Dimensions D and E1 do not include mold flash or protrusions. Mold flash or protrusions shall not exceed .010" per side.
- Dimensioning and tolerancing per ASME Y14.5M.
BSC: Basic Dimension. Theoretically exact value shown without tolerances.

Microchip Technology Drawing C04-005B

MCP2030A

14-Lead Plastic Small Outline (SL) – Narrow, 3.90 mm Body [SOIC]

Note: For the most current package drawings, please see the Microchip Packaging Specification located at <http://www.microchip.com/packageing>

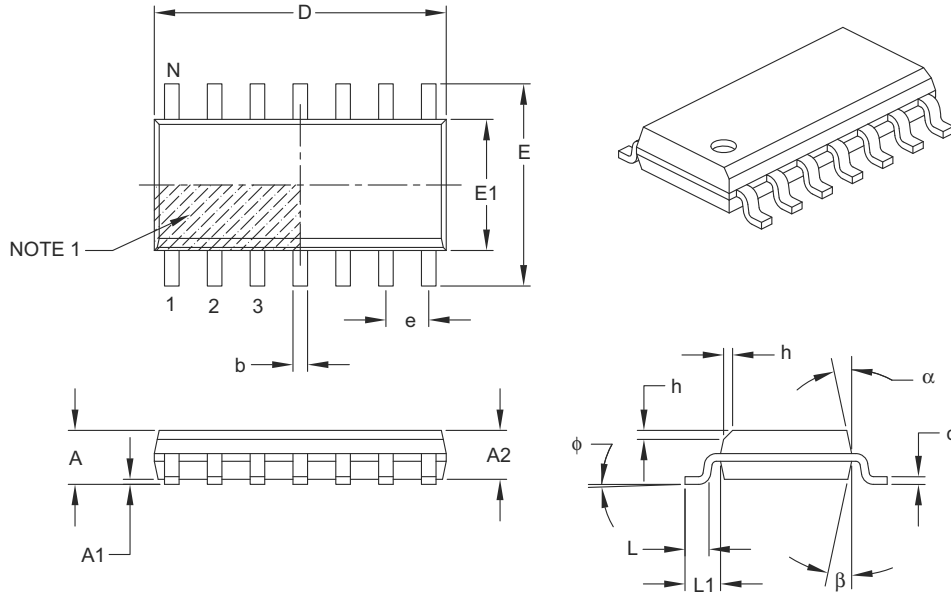

Dimension Limits	Units	MILLIMETERS		
		MIN	NOM	MAX
Number of Pins	N	14		
Pitch	e	1.27 BSC		
Overall Height	A	–	–	1.75
Molded Package Thickness	A2	1.25	–	–
Standoff §	A1	0.10	–	0.25
Overall Width	E	6.00 BSC		
Molded Package Width	E1	3.90 BSC		
Overall Length	D	8.65 BSC		
Chamfer (optional)	h	0.25	–	0.50
Foot Length	L	0.40	–	1.27
Footprint	L1	1.04 REF		
Foot Angle	ϕ	0°	–	8°
Lead Thickness	c	0.17	–	0.25
Lead Width	b	0.31	–	0.51
Mold Draft Angle Top	α	5°	–	15°
Mold Draft Angle Bottom	β	5°	–	15°

Notes:

- Pin 1 visual index feature may vary, but must be located within the hatched area.
- § Significant Characteristic.
- Dimensions D and E1 do not include mold flash or protrusions. Mold flash or protrusions shall not exceed 0.15 mm per side.
- Dimensioning and tolerancing per ASME Y14.5M.

BSC: Basic Dimension. Theoretically exact value shown without tolerances.

REF: Reference Dimension, usually without tolerance, for information purposes only.

Microchip Technology Drawing C04-065B

14-Lead Plastic Small Outline (SL) - Narrow, 3.90 mm Body [SOIC]

Note: For the most current package drawings, please see the Microchip Packaging Specification located at <http://www.microchip.com/packaging>

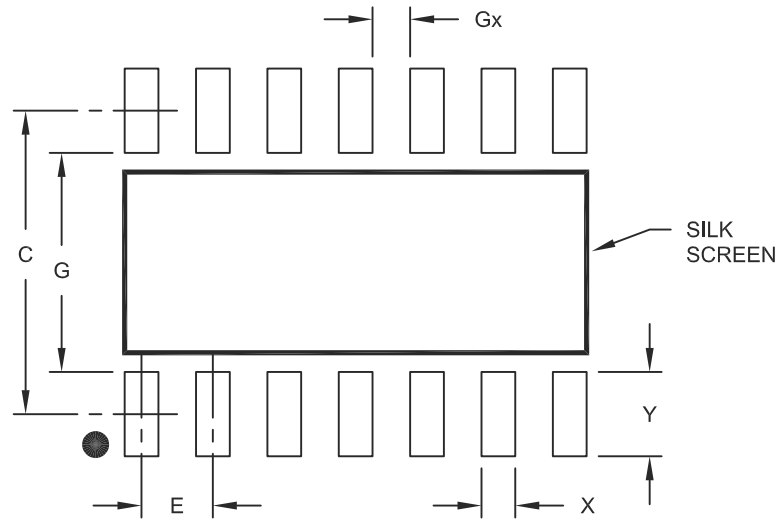

RECOMMENDED LAND PATTERN

Dimension Limits	Units	MILLIMETERS		
		MIN	NOM	MAX
Contact Pitch	E	1.27 BSC		
Contact Pad Spacing	C		5.40	
Contact Pad Width	X			0.60
Contact Pad Length	Y			1.50
Distance Between Pads	Gx	0.67		
Distance Between Pads	G	3.90		

Notes:

1. Dimensioning and tolerancing per ASME Y14.5M

BSC: Basic Dimension. Theoretically exact value shown without tolerances.

Microchip Technology Drawing No. C04-2065A

MCP2030A

14-Lead Plastic Thin Shrink Small Outline (ST) - 4.4 mm Body [TSSOP]

Note: For the most current package drawings, please see the Microchip Packaging Specification located at <http://www.microchip.com/packaging>

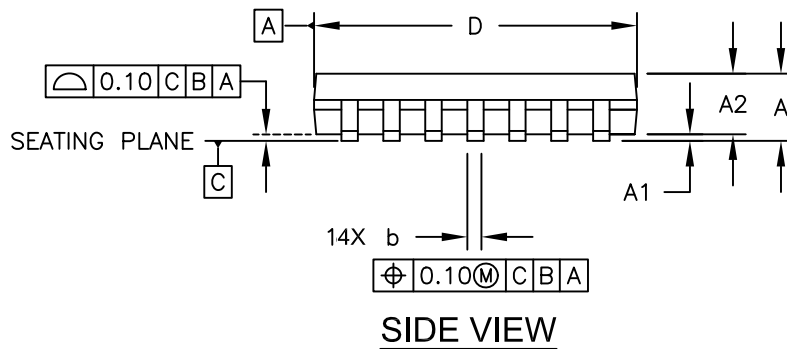
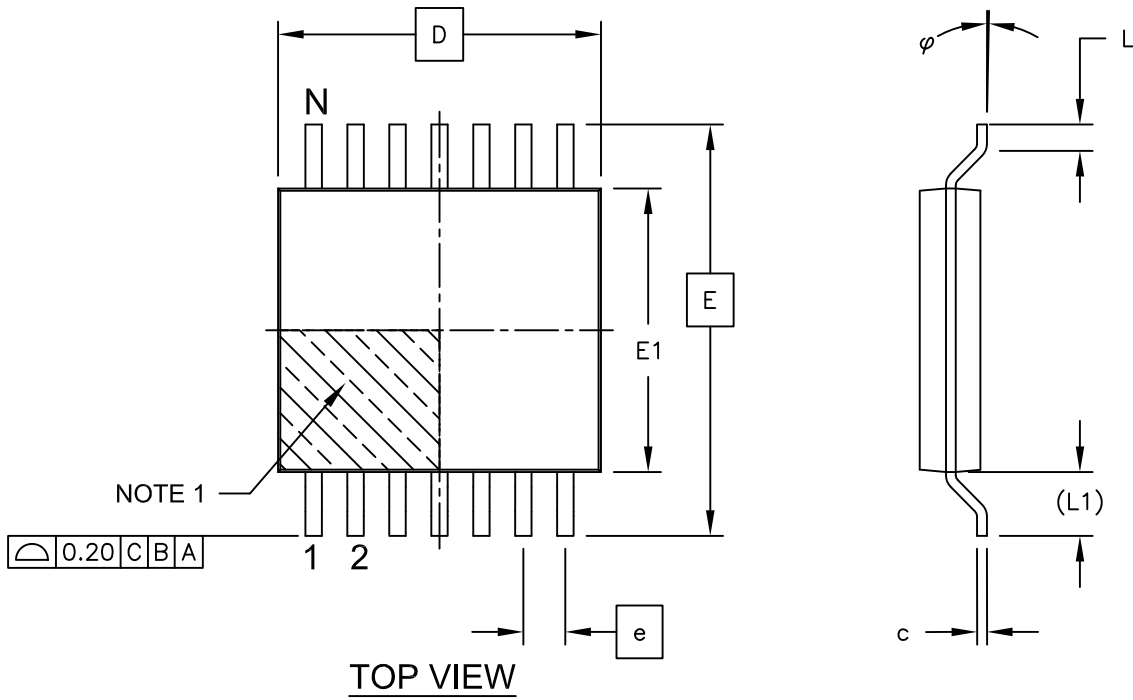

Microchip Technology Drawing C04-087C Sheet 1 of 2

14-Lead Plastic Thin Shrink Small Outline (ST) - 4.4 mm Body [TSSOP]

Note: For the most current package drawings, please see the Microchip Packaging Specification located at <http://www.microchip.com/packaging>

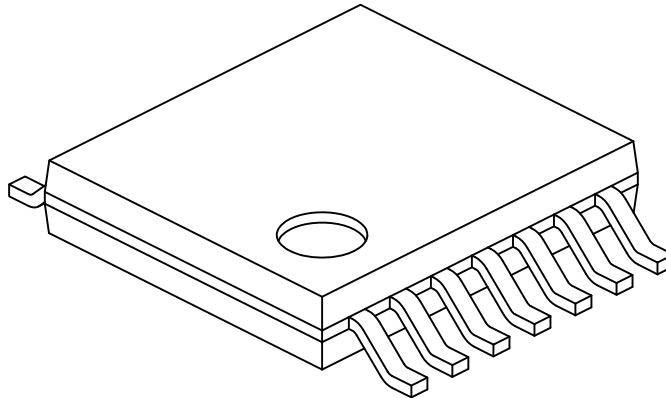

Dimension Limits	Units	MILLIMETERS		
		MIN	NOM	MAX
Number of Pins	N	14		
Pitch	e	0.65 BSC		
Overall Height	A	-	-	1.20
Molded Package Thickness	A2	0.80	1.00	1.05
Standoff	A1	0.05	-	0.15
Overall Width	E	6.40 BSC		
Molded Package Width	E1	4.30	4.40	4.50
Molded Package Length	D	4.90	5.00	5.10
Foot Length	L	0.45	0.60	0.75
Footprint	(L1)	1.00 REF		
Foot Angle	φ	0°	-	8°
Lead Thickness	c	0.09	-	0.20
Lead Width	b	0.19	-	0.30

Notes:

- Pin 1 visual index feature may vary, but must be located within the hatched area.
- Dimensions D and E1 do not include mold flash or protrusions. Mold flash or protrusions shall not exceed 0.15mm per side.
- Dimensioning and tolerancing per ASME Y14.5M
 - BSC: Basic Dimension. Theoretically exact value shown without tolerances.
 - REF: Reference Dimension, usually without tolerance, for information purposes only.

Microchip Technology Drawing No. C04-087C Sheet 2 of 2

MCP2030A

14-Lead Plastic Thin Shrink Small Outline (ST) - 4.4 mm Body [TSSOP]

Note: For the most current package drawings, please see the Microchip Packaging Specification located at <http://www.microchip.com/packaging>

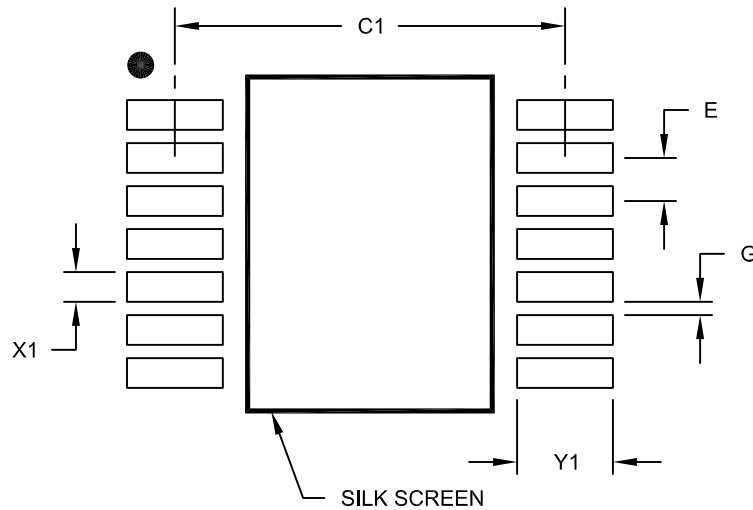

RECOMMENDED LAND PATTERN

Dimension Limits	Units	MILLIMETERS		
		MIN	NOM	MAX
Contact Pitch	E	0.65 BSC		
Contact Pad Spacing	C1		5.90	
Contact Pad Width (X14)	X1			0.45
Contact Pad Length (X14)	Y1			1.45
Distance Between Pads	G	0.20		

Notes:

1. Dimensioning and tolerancing per ASME Y14.5M

BSC: Basic Dimension. Theoretically exact value shown without tolerances.

Microchip Technology Drawing No. C04-2087A

APPENDIX A: REVISION HISTORY

Revision B (March 2011)

The following is the list of modifications:

- Updated document templates.

Revision A (January 2010)

- Original Release of this Document.

MCP2030A

NOTES:

PRODUCT IDENTIFICATION SYSTEM

To order or obtain information, e.g., on pricing or delivery, contact the local Microchip sales office.

<u>PART NO.</u>	<u>X</u>	<u>/XX</u>	<u>XXX</u>
Device	Temperature Range	Package	Pattern
Device	DSTEMP: Standard V_{DD} range DSTEMPT: (Tape and Reel)		
Temperature Range	I = -40°C to +85°C		
Package	P = Plastic Dual In-line (300 mil), 14-lead SL = Plastic Small Outline (150 mil body), 14-lead ST = Plastic Thin Shrink Small Outline (4.4 mm), 14-lead		

Examples:

- a) DSTEMP-I/P: Industrial Temp., 14LD PDIP.
- b) DSTEMP-I/SL: Industrial Temp., 14LD SOIC.
- c) DSTEMP-I/ST: Industrial Temp., 14LD TSSOP.

MCP2030A

NOTES:

Note the following details of the code protection feature on Microchip devices:

- Microchip products meet the specification contained in their particular Microchip Data Sheet.
- Microchip believes that its family of products is one of the most secure families of its kind on the market today, when used in the intended manner and under normal conditions.
- There are dishonest and possibly illegal methods used to breach the code protection feature. All of these methods, to our knowledge, require using the Microchip products in a manner outside the operating specifications contained in Microchip's Data Sheets. Most likely, the person doing so is engaged in theft of intellectual property.
- Microchip is willing to work with the customer who is concerned about the integrity of their code.
- Neither Microchip nor any other semiconductor manufacturer can guarantee the security of their code. Code protection does not mean that we are guaranteeing the product as "unbreakable."

Code protection is constantly evolving. We at Microchip are committed to continuously improving the code protection features of our products. Attempts to break Microchip's code protection feature may be a violation of the Digital Millennium Copyright Act. If such acts allow unauthorized access to your software or other copyrighted work, you may have a right to sue for relief under that Act.

Information contained in this publication regarding device applications and the like is provided only for your convenience and may be superseded by updates. It is your responsibility to ensure that your application meets with your specifications. MICROCHIP MAKES NO REPRESENTATIONS OR WARRANTIES OF ANY KIND WHETHER EXPRESS OR IMPLIED, WRITTEN OR ORAL, STATUTORY OR OTHERWISE, RELATED TO THE INFORMATION, INCLUDING BUT NOT LIMITED TO ITS CONDITION, QUALITY, PERFORMANCE, MERCHANTABILITY OR FITNESS FOR PURPOSE. Microchip disclaims all liability arising from this information and its use. Use of Microchip devices in life support and/or safety applications is entirely at the buyer's risk, and the buyer agrees to defend, indemnify and hold harmless Microchip from any and all damages, claims, suits, or expenses resulting from such use. No licenses are conveyed, implicitly or otherwise, under any Microchip intellectual property rights.

Trademarks

The Microchip name and logo, the Microchip logo, dsPIC, KEELOQ, KEELOQ logo, MPLAB, PIC, PICmicro, PICSTART, PIC³² logo, rPIC and UNI/O are registered trademarks of Microchip Technology Incorporated in the U.S.A. and other countries.

FilterLab, Hampshire, HI-TECH C, Linear Active Thermistor, MXDEV, MXLAB, SEEVAL and The Embedded Control Solutions Company are registered trademarks of Microchip Technology Incorporated in the U.S.A.

Analog-for-the-Digital Age, Application Maestro, CodeGuard, dsPICDEM, dsPICDEM.net, dsPICworks, dsSPEAK, ECAN, ECONOMONITOR, FanSense, HI-TIDE, In-Circuit Serial Programming, ICSP, Mindi, MiWi, MPASM, MPLAB Certified logo, MPLIB, MPLINK, mTouch, Omniscient Code Generation, PICC, PICC-18, PICDEM, PICDEM.net, PICkit, PICTail, REAL ICE, rLAB, Select Mode, Total Endurance, TSHARC, UniWinDriver, WiperLock and ZENA are trademarks of Microchip Technology Incorporated in the U.S.A. and other countries.

SQTP is a service mark of Microchip Technology Incorporated in the U.S.A.

All other trademarks mentioned herein are property of their respective companies.

© 2011, Microchip Technology Incorporated, Printed in the U.S.A., All Rights Reserved.

 Printed on recycled paper.

ISBN: 978-1-60932-882-5

Microchip received ISO/TS-16949:2002 certification for its worldwide headquarters, design and wafer fabrication facilities in Chandler and Tempe, Arizona; Gresham, Oregon and design centers in California and India. The Company's quality system processes and procedures are for its PIC® MCUs and dsPIC® DSCs, KEELOQ® code hopping devices, Serial EEPROMs, microperipherals, nonvolatile memory and analog products. In addition, Microchip's quality system for the design and manufacture of development systems is ISO 9001:2000 certified.

**QUALITY MANAGEMENT SYSTEM
CERTIFIED BY DNV
== ISO/TS 16949:2002 ==**



MICROCHIP

Worldwide Sales and Service

AMERICAS

Corporate Office
2355 West Chandler Blvd.
Chandler, AZ 85224-6199
Tel: 480-792-7200
Fax: 480-792-7277
Technical Support:
<http://www.microchip.com/support>
Web Address:
www.microchip.com

Atlanta
Duluth, GA
Tel: 678-957-9614
Fax: 678-957-1455

Boston
Westborough, MA
Tel: 774-760-0087
Fax: 774-760-0088

Chicago
Itasca, IL
Tel: 630-285-0071
Fax: 630-285-0075

Cleveland
Independence, OH
Tel: 216-447-0464
Fax: 216-447-0643

Dallas
Addison, TX
Tel: 972-818-7423
Fax: 972-818-2924

Detroit
Farmington Hills, MI
Tel: 248-538-2250
Fax: 248-538-2260

Indianapolis
Noblesville, IN
Tel: 317-773-8323
Fax: 317-773-5453

Los Angeles
Mission Viejo, CA
Tel: 949-462-9523
Fax: 949-462-9608

Santa Clara
Santa Clara, CA
Tel: 408-961-6444
Fax: 408-961-6445

Toronto
Mississauga, Ontario,
Canada
Tel: 905-673-0699
Fax: 905-673-6509

ASIA/PACIFIC

Asia Pacific Office
Suites 3707-14, 37th Floor
Tower 6, The Gateway
Harbour City, Kowloon
Hong Kong
Tel: 852-2401-1200
Fax: 852-2401-3431

Australia - Sydney
Tel: 61-2-9868-6733
Fax: 61-2-9868-6755

China - Beijing
Tel: 86-10-8528-2100
Fax: 86-10-8528-2104

China - Chengdu
Tel: 86-28-8665-5511
Fax: 86-28-8665-7889

China - Chongqing
Tel: 86-23-8980-9588
Fax: 86-23-8980-9500

China - Hong Kong SAR
Tel: 852-2401-1200
Fax: 852-2401-3431

China - Nanjing
Tel: 86-25-8473-2460
Fax: 86-25-8473-2470

China - Qingdao
Tel: 86-532-8502-7355
Fax: 86-532-8502-7205

China - Shanghai
Tel: 86-21-5407-5533
Fax: 86-21-5407-5066

China - Shenyang
Tel: 86-24-2334-2829
Fax: 86-24-2334-2393

China - Shenzhen
Tel: 86-755-8203-2660
Fax: 86-755-8203-1760

China - Wuhan
Tel: 86-27-5980-5300
Fax: 86-27-5980-5118

China - Xian
Tel: 86-29-8833-7252
Fax: 86-29-8833-7256

China - Xiamen
Tel: 86-592-2388138
Fax: 86-592-2388130

China - Zhuhai
Tel: 86-756-3210040
Fax: 86-756-3210049

ASIA/PACIFIC

India - Bangalore
Tel: 91-80-3090-4444
Fax: 91-80-3090-4123

India - New Delhi
Tel: 91-11-4160-8631
Fax: 91-11-4160-8632

India - Pune
Tel: 91-20-2566-1512
Fax: 91-20-2566-1513

Japan - Yokohama
Tel: 81-45-471- 6166
Fax: 81-45-471-6122

Korea - Daegu
Tel: 82-53-744-4301
Fax: 82-53-744-4302

Korea - Seoul
Tel: 82-2-554-7200
Fax: 82-2-558-5932 or
82-2-558-5934

Malaysia - Kuala Lumpur
Tel: 60-3-6201-9857
Fax: 60-3-6201-9859

Malaysia - Penang
Tel: 60-4-227-8870
Fax: 60-4-227-4068

Philippines - Manila
Tel: 63-2-634-9065
Fax: 63-2-634-9069

Singapore
Tel: 65-6334-8870
Fax: 65-6334-8850

Taiwan - Hsin Chu
Tel: 886-3-6578-300
Fax: 886-3-6578-370

Taiwan - Kaohsiung
Tel: 886-7-213-7830
Fax: 886-7-330-9305

Taiwan - Taipei
Tel: 886-2-2500-6610
Fax: 886-2-2508-0102

Thailand - Bangkok
Tel: 66-2-694-1351
Fax: 66-2-694-1350

EUROPE

Austria - Wels
Tel: 43-7242-2244-39
Fax: 43-7242-2244-393

Denmark - Copenhagen
Tel: 45-4450-2828
Fax: 45-4485-2829

France - Paris
Tel: 33-1-69-53-63-20
Fax: 33-1-69-30-90-79

Germany - Munich
Tel: 49-89-627-144-0
Fax: 49-89-627-144-44

Italy - Milan
Tel: 39-0331-742611
Fax: 39-0331-466781

Netherlands - Drunen
Tel: 31-416-690399
Fax: 31-416-690340

Spain - Madrid
Tel: 34-91-708-08-90
Fax: 34-91-708-08-91

UK - Wokingham
Tel: 44-118-921-5869
Fax: 44-118-921-5820

02/18/11

X-ON Electronics

Largest Supplier of Electrical and Electronic Components

Click to view similar products for [RF Front End](#) category:

Click to view products by [Microchip](#) manufacturer:

Other Similar products are found below :

[SE2622L-R](#) [BGM1032N7E6327XUSA1](#) [LX5586LL](#) [LX5586HLL](#) [LX5586ALL](#) [SKY66111-21](#) [SKY65728-11](#) [SKY68000-31](#) [SKY85308-11](#)
[SKY85302-11](#) [SKY85300-21](#) [ADTR1107ACCZ](#) [LMP91051MTX/NOPB](#) [SE5501L-R](#) [QPF4519SR](#) [SE5503A-R](#) [ADA8282WBCPZ](#)
[ADRF5545ABCPZN](#) [ADRF5545ABCPZN-R7](#) [AD8283WBCPZ](#) [AD8284WCSVZ](#) [ADRF5547BCPZN](#) [ADRF5547BCPZN-R7](#)
[ADRF5549BCPZN](#) [ADRF5549BCPZN-R7](#) [HV7350K6-G](#) [SE5516A-R](#) [MCP2030-I/SL](#) [MAX2335ETI+](#) [MD2131K7-G](#) [MD2134K7-G](#)
[RFFM4554SR](#) [RFFM4554TR7](#) [RFFM8504SR](#) [RFFM8511SR](#) [RFFM4552TR7](#) [RFFM4503TR7](#) [RFFM6903TR13](#) [HV7351K6-G](#) [MCP2035-](#)
[I/ST](#) [SE2614BT-R](#) [SE2438T-R](#) [SST12LF02-QXCE](#) [SST12LF09-Q3CE](#) [PN5180A0HN/C3E](#) [RFX2401C](#) [RFX2402E](#) [SKY85201-11](#)
[RFFM4591FTR7](#) [RFFM8211TR7](#)