



**MCP3905/6**  
**Evaluation Board**  
**User's Guide**

---

**Note the following details of the code protection feature on Microchip devices:**

- Microchip products meet the specification contained in their particular Microchip Data Sheet.
- Microchip believes that its family of products is one of the most secure families of its kind on the market today, when used in the intended manner and under normal conditions.
- There are dishonest and possibly illegal methods used to breach the code protection feature. All of these methods, to our knowledge, require using the Microchip products in a manner outside the operating specifications contained in Microchip's Data Sheets. Most likely, the person doing so is engaged in theft of intellectual property.
- Microchip is willing to work with the customer who is concerned about the integrity of their code.
- Neither Microchip nor any other semiconductor manufacturer can guarantee the security of their code. Code protection does not mean that we are guaranteeing the product as "unbreakable."

Code protection is constantly evolving. We at Microchip are committed to continuously improving the code protection features of our products. Attempts to break Microchip's code protection feature may be a violation of the Digital Millennium Copyright Act. If such acts allow unauthorized access to your software or other copyrighted work, you may have a right to sue for relief under that Act.

---

Information contained in this publication regarding device applications and the like is provided only for your convenience and may be superseded by updates. It is your responsibility to ensure that your application meets with your specifications. MICROCHIP MAKES NO REPRESENTATIONS OR WARRANTIES OF ANY KIND WHETHER EXPRESS OR IMPLIED, WRITTEN OR ORAL, STATUTORY OR OTHERWISE, RELATED TO THE INFORMATION, INCLUDING BUT NOT LIMITED TO ITS CONDITION, QUALITY, PERFORMANCE, MERCHANTABILITY OR FITNESS FOR PURPOSE. Microchip disclaims all liability arising from this information and its use. Use of Microchip's products as critical components in life support systems is not authorized except with express written approval by Microchip. No licenses are conveyed, implicitly or otherwise, under any Microchip intellectual property rights.

**Trademarks**

The Microchip name and logo, the Microchip logo, Accuron, dsPIC, KEELOQ, microID, MPLAB, PIC, PICmicro, PICSTART, PRO MATE, PowerSmart, rPIC, and SmartShunt are registered trademarks of Microchip Technology Incorporated in the U.S.A. and other countries.

AmpLab, FilterLab, Migratable Memory, MXDEV, MXLAB, PICMASTER, SEEVAL, SmartSensor and The Embedded Control Solutions Company are registered trademarks of Microchip Technology Incorporated in the U.S.A.

Analog-for-the-Digital Age, Application Maestro, dsPICDEM, dsPICDEM.net, dsPICworks, ECAN, ECONOMONITOR, FanSense, FlexROM, fuzzyLAB, In-Circuit Serial Programming, ICSP, ICEPIC, Linear Active Thermistor, MPASM, MPLIB, MPLINK, MPSIM, PICkit, PICDEM, PICDEM.net, PICLAB, PICtail, PowerCal, PowerInfo, PowerMate, PowerTool, rLAB, rPICDEM, Select Mode, Smart Serial, SmartTel, Total Endurance and WiperLock are trademarks of Microchip Technology Incorporated in the U.S.A. and other countries.

SQTP is a service mark of Microchip Technology Incorporated in the U.S.A.

All other trademarks mentioned herein are property of their respective companies.

© 2005, Microchip Technology Incorporated, Printed in the U.S.A., All Rights Reserved.

 Printed on recycled paper.

**QUALITY MANAGEMENT SYSTEM  
CERTIFIED BY DNV  
== ISO/TS 16949:2002 ==**

*Microchip received ISO/TS-16949:2002 quality system certification for its worldwide headquarters, design and wafer fabrication facilities in Chandler and Tempe, Arizona and Mountain View, California in October 2003. The Company's quality system processes and procedures are for its PICmicro® 8-bit MCUs, KEELOQ® code hopping devices, Serial EEPROMs, microperipherals, nonvolatile memory and analog products. In addition, Microchip's quality system for the design and manufacture of development systems is ISO 9001:2000 certified.*



# MCP3905/6 EVALUATION BOARD USER'S GUIDE

---

---

## Table of Contents

---

---

<b>Preface</b> .....	<b>1</b>
<b>Chapter 1. Product Overview</b>	
1.1 Introduction .....	5
1.2 What is the MCP3905/6 Evaluation Board? .....	5
1.3 What the MCP3905/6 Evaluation Board Kit Includes .....	5
<b>Chapter 2. Installation and Operation</b>	
2.1 Introduction .....	7
2.2 Features .....	8
2.3 Getting Started .....	8
2.4 MCP3905/6 Evaluation Board Overview .....	11
2.5 Functional Block Descriptions .....	11
<b>Appendix A. Schematics and Layouts</b> .....	<b>15</b>
A.1 Introduction .....	15
A.2 Schematics and PCB Layout .....	15
A.3 Board Schematic .....	16
A.4 Board Layout – Top Layer and Silk-Screen .....	17
A.5 Board Layout – Bottom Layer .....	18
<b>Appendix B. Bill Of Materials (BOM)</b> .....	<b>19</b>
<b>Worldwide Sales and Service</b> .....	<b>22</b>

# MCP3905/6 Evaluation Board User's Guide

---

---

NOTES:

---

---

## Preface

---

---

### NOTICE TO CUSTOMERS

All documentation becomes dated, and this manual is no exception. Microchip tools and documentation are constantly evolving to meet customer needs, so some actual dialogs and/or tool descriptions may differ from those in this document. Please refer to our web site ([www.microchip.com](http://www.microchip.com)) to obtain the latest documentation available.

Documents are identified with a “DS” number. This number is located on the bottom of each page, in front of the page number. The numbering convention for the DS number is “DSXXXXA”, where “XXXX” is the document number and “A” is the revision level of the document.

## INTRODUCTION

This chapter contains general information that will be useful to know before using the MCP3905/6 Evaluation Board. Items discussed in this chapter include:

- Document Layout
- Conventions Used in this Guide
- Recommended Reading
- The Microchip Web Site
- Customer Support
- Document Revision History

## DOCUMENT LAYOUT

This document describes how to use the MCP3905/6 Evaluation Board. The manual layout is as follows:

- **Chapter 1. “Product Overview”** – Important information about the MCP3905/6 Evaluation Board.
- **Chapter 2. “Installation and Operation”** – Includes a detailed description of each block and instructions on how to get started with this board.
- **Appendix A. “Schematics and Layouts”** – Shows the schematic and board layout diagrams for the MCP3905/6 Evaluation Board.
- **Appendix B. “Bill Of Materials (BOM)”** – Lists the parts used to build the MCP3905/6 Evaluation Board.

# MCP3905/6 Evaluation Board User's Guide

---

## CONVENTIONS USED IN THIS GUIDE

This manual uses the following documentation conventions:

### DOCUMENTATION CONVENTIONS

Description	Represents	Examples
<b>Arial font:</b>		
Italic characters	Referenced books	<i>MPLAB<sup>®</sup> IDE User's Guide</i>
	Emphasized text	...is the <i>only</i> compiler...
Initial caps	A window	the Output window
	A dialog	the Settings dialog
	A menu selection	select Enable Programmer
Quotes	A field name in a window or dialog	"Save project before build"
Underlined, italic text with right angle bracket	A menu path	<u><i>File&gt;Save</i></u>
Bold characters	A dialog button	Click <b>OK</b>
	A tab	Click the <b>Power</b> tab
Text in angle brackets < >	A key on the keyboard	Press <Enter>, <F1>
<b>Courier New font:</b>		
Plain Courier New	Sample source code	#define START
	Filenames	autoexec.bat
	File paths	c:\mcc18\h
	Keywords	_asm, _endasm, static
	Command-line options	-Opa+, -Opa-
	Bit values	0, 1
	Constants	0xFF, 'A'
Italic Courier	A variable argument	<i>file.o</i> , where <i>file</i> can be any valid filename
Square brackets [ ]	Optional arguments	mcc18 [options] <i>file</i> [options]
Curly brackets and pipe character: {   }	Choice of mutually exclusive arguments; an OR selection	errorlevel {0 1}
Ellipses...	Replaces repeated text	var_name [, var_name...]
	Represents code supplied by user	void main (void) { ... }

## RECOMMENDED READING

This user's guide describes how to use MCP3905/6 Evaluation Board. The following Microchip documents are available and recommended as supplemental reference resources.

**MCP3905 Data Sheet, “Energy Metering IC with Active Real Power Pulse Output” (DS21948)**

This data sheet provides detailed information regarding the MCP3905 device.

**AN994 “IEC Compliant Active Energy Meter Design Using The MCP3905/6” (DS00994)**

This application note documents the design decisions associated with this reference design.

**MCP3905/6 Energy Meter Reference Design (DS51565)**

This reference design is a stand-alone, low-cost energy meter. It can act as either a stand-alone energy meter, or as the analog front-end design for LCD microcontroller-based meters. This reference design is compliant with EMC requirements per energy metering standards IEC62053 and legacy IEC61036, IEC1046 and IEC687.

## THE MICROCHIP WEB SITE

Microchip provides online support via our web site at [www.microchip.com](http://www.microchip.com). This web site is used as a means to make files and information easily available to customers. Accessible by using your favorite Internet browser, the web site contains the following information:

- **Product Support** – Data sheets and errata, application notes and sample programs, design resources, user's guides and hardware support documents, latest software releases and archived software
- **General Technical Support** – Frequently Asked Questions (FAQs), technical support requests, online discussion groups, Microchip consultant program member listing
- **Business of Microchip** – Product selector and ordering guides, latest Microchip press releases, listing of seminars and events, listings of Microchip sales offices, distributors and factory representatives

## CUSTOMER SUPPORT

Users of Microchip products can receive assistance through several channels:

- Distributor or Representative
- Local Sales Office
- Field Application Engineer (FAE)
- Technical Support
- Development Systems Information Line

Customers should contact their distributor, representative or field application engineer (FAE) for support. Local sales offices are also available to help customers. A listing of sales offices and locations is included in the back of this document.

Technical support is available through the web site at: <http://support.microchip.com>

## DOCUMENT REVISION HISTORY

**Revision A (August 2005)**

- Initial Release of this Document.

# MCP3905/6 Evaluation Board User's Guide

---

NOTES:



---

---

## Chapter 1. Product Overview

---

---

### 1.1 INTRODUCTION

This chapter provides an overview of the MCP3905/6 Evaluation Board and covers the following topics:

- What is the MCP3905/6 Evaluation Board?
- What the MCP3905/6 Evaluation Board kit includes

### 1.2 WHAT IS THE MCP3905/6 EVALUATION BOARD?

The MCP3905/6 Evaluation Board is designed to test a variety of meter designs using the MCP3905/06 energy metering Integrated Circuit (IC). Stand-alone MCP3905/6 energy meter designs, as well as those using a PICmicro<sup>®</sup> Microcontroller Unit (MCU), are easily designed using this evaluation board as the prototype Analog Front-End (AFE).

### 1.3 WHAT THE MCP3905/6 EVALUATION BOARD KIT INCLUDES

This MCP3905/6 Evaluation Board Kit includes:

- The MCP3905/6 Evaluation Board (with MCP3905 installed)
- MCP3905/6 Evaluation Board User's Guide (DS51567)
- MCP3905 Data Sheet, "*Energy Metering IC with Active Real Power Pulse Output*" (DS21948)
- AN994 "*IEC Compliant Active Energy Meter Design Using The MCP3905/6*" (DS00994)

# MCP3905/6 Evaluation Board User's Guide

---

NOTES:

**Chapter 2. Installation and Operation**

**2.1 INTRODUCTION**

The MCP3905/6 Evaluation Board provides easy evaluation of the MCP3905 energy-metering IC to metering customers. High-voltage AC input line and load connections, including the necessary space for current shunt or Current Transformer (CT) evaluation, are all included. Jumpers with shunts and a reset switch are connected to the MCP3905/6 device to further facilitate device evaluation and meter design. Multiple input channel configuration circuits are included for both differential and single-ended signals. LEDs for evaluating the MCP3905/6 output visually are on-board. A standard 14-pin PICtail™ daughter board header is included for a connection to a variety of Microchip PICmicro® microcontroller demonstration (demo) boards, allowing for PIC16, PIC18 and dsPIC® DSC development system meter designs. This connection can also be isolated using an on-board, optical-isolation IC.

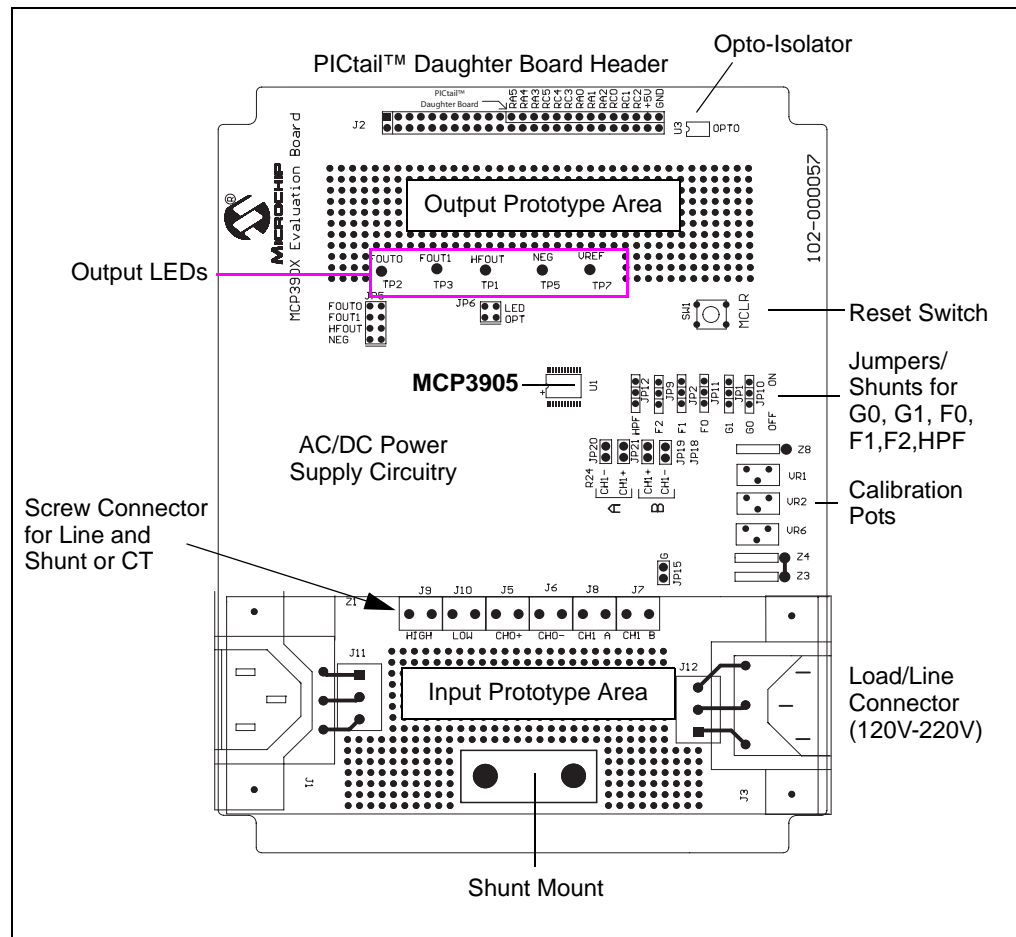

**FIGURE 2-1:** MCP3905/6 Evaluation Board.

# MCP3905/6 Evaluation Board User's Guide

## 2.2 FEATURES

The MCP3905/6 Evaluation Board has the following features:

- Large space for easy connection to AC line and loads provide area for experiments using different current-sensing elements
- Easy connection to both PICDEM™ demonstration boards for a variety of PICmicro® MCU-based meter designs
- Jumpers and shunts for simple device configuration
- On-board, low-cost AC-to-DC power supply circuitry to demonstrate the low-cost MCP3905 AFE design used in the MCP3905/6 Energy Meter Reference Design (DS51565)
- EMC immunity and Printed Circuit Board (PCB) design as used in the MCP3905/6 Energy Meter Reference Design (DS51565)
- Designed to fit inside recommended plastic enclosure for safe, high-voltage demonstrations and experiments (enclosure is optional and is not included)

## 2.3 GETTING STARTED

The following example is given to describe how to use this evaluation board using a current-sensing shunt, 220 VAC line voltage and a 10A load. All connections described in this section are dependent on the choice of current-sensing element. A 250  $\mu\Omega$  shunt is selected as the current-sensing element.

### 2.3.1 Step 1: Install Current-Sensing Element and Make Appropriate Input Connections

Use the input prototype area to connect the line/load and current-sensing elements to the appropriate screw-type connector. An example of connecting the shunt is shown in Figure 2-2. Please note that the phase-side of the line should be used as the GND reference to the MCP3905/6 Evaluation Board when using the AC/DC power supply circuit in shunt examples like the one in Figure 2-2.

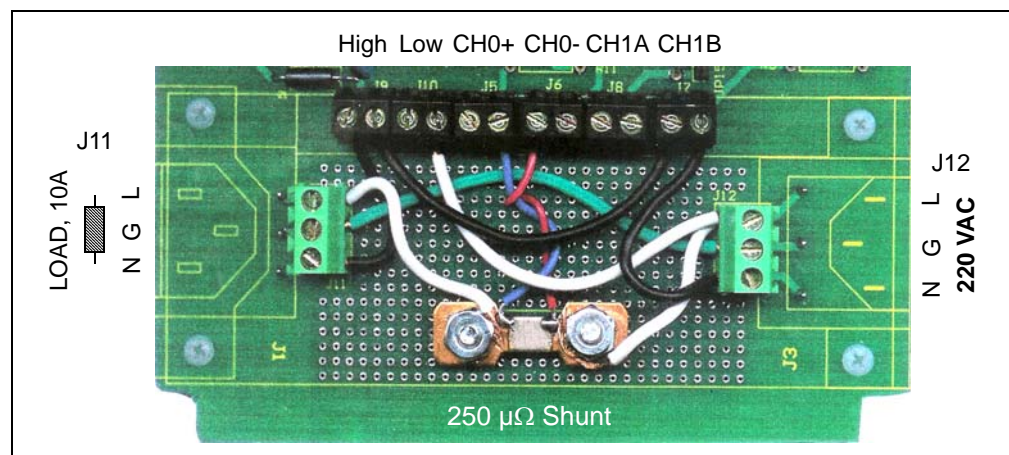

**FIGURE 2-2:** Example Input Prototype Area Connections Using Shunt. The system is biased to the line-side of the two-wire power supply.



# MCP3905/6 Evaluation Board User's Guide

---

## 2.3.4 Step 4: Select desired output evaluation method

Jumpers JP5 and JP6 select the output evaluation method. In this example, we are selecting HF<sub>OUT</sub> connected to the LED for blink.

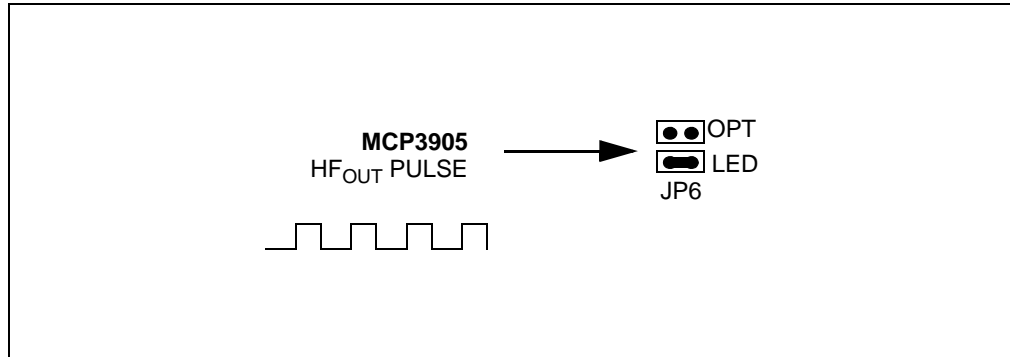

**FIGURE 2-5:** Connecting the MCP3905 High-Frequency Output to the LED.

## 2.3.5 Step 5: Select +5V Source

With the connections for J9 and J11 made in Figure 2-2, the 220V AC/DC power supply circuit can be used as the +5V supply. Here we put JP4 in the "INT" position for internal connection.

## 2.3.6 Step 6: Connect Line and Load and Observe MCP3905 Output

Once all jumper positions have been selected, connecting 220V with the correct L,G,N connections and an appropriate load (10A in this example) will power both the MCP3905/6 Evaluation Board and create the MCP3905 output (LED, BLINKING) in Figure 2-5.

## 2.4 MCP3905/6 EVALUATION BOARD OVERVIEW

The functional blocks of the MCP3905/06 Evaluation Board will be described in this section. For more detailed information regarding design decisions and approaches to IEC1036 compliance, refer to AN994, "IEC Compliant Active Energy Meter Design Using The MCP3905/6" (DS00994). For a detailed circuit schematic, refer to **Appendix A. "Schematics and Layouts"** and **Appendix B. "Bill-Of-Materials (BOM)"** for a list of the parts used to build the MCP3905/6 Evaluation Board.

## 2.5 FUNCTIONAL BLOCK DESCRIPTIONS

### 2.5.1 Input Prototype Area

All line/load, shunt and CT connections are to be made next to the screw-type connectors J5-J12. This area includes two mounting holes for a standard shunt connector. All high-voltage connections go onto this prototype area.

### 2.5.2 High-Voltage Input Connections (J5-12)

These screw-type connections are for shunts, CTs, line and load. The shunt resistance should be placed in parallel with J5 and J6. A variety of experiments using shunts and CTs can be performed here in conjunction with the input prototype area.

J9 and J10 feed the AC/DC power supply circuitry. J10 is the reference connection to the entire board. Shunt-type meters should be connected to the line-side. One example is given in the figure below.

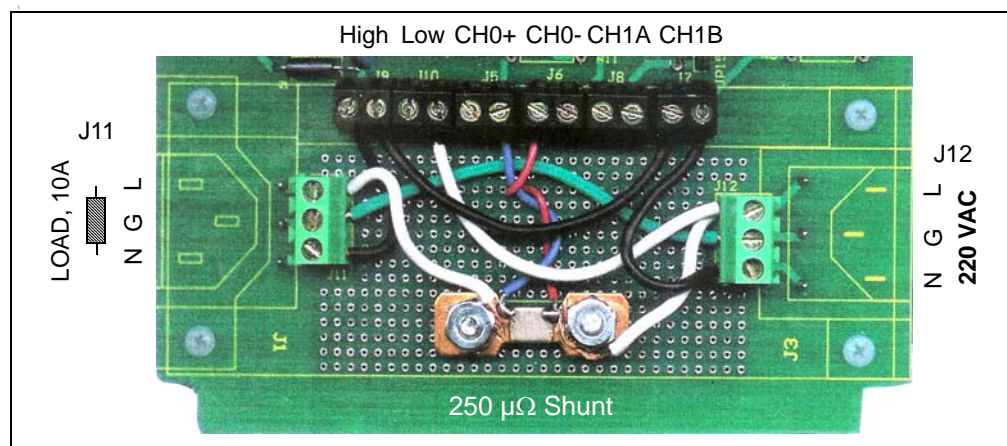

**FIGURE 2-6:** Example Wiring Using Two-Wire System with Shunt

### 2.5.3 Jumpers and Shunts for MCP3905 Gain and Frequency Constant $F_C$ Selection (JP1, 2, 9-12)

Jumpers and shunts for both logic-high and logic-low are included for all gain and frequency constant selections, with filter options Off and On columns being clearly labelled.

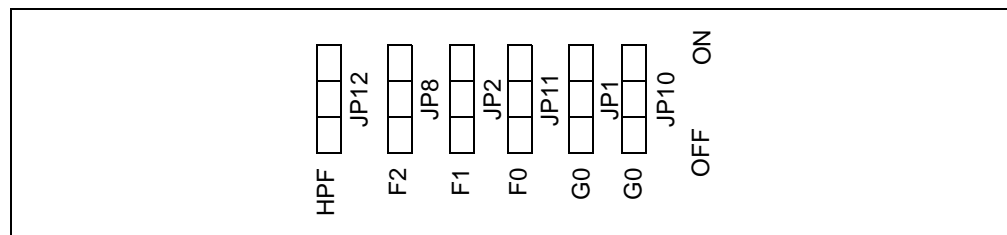
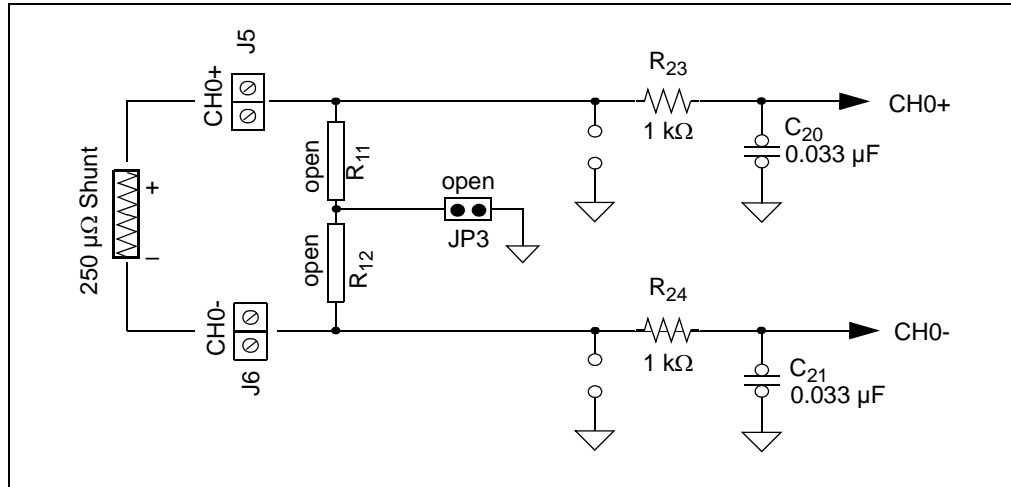

**FIGURE 2-7:** MCP3905 Jumper Selections

# MCP3905/6 Evaluation Board User's Guide

## 2.5.4 Jumpers and Shunts for MCP3905 Channel 0 Input Configurations (JP5, JP6, ZN-N)

Channel 0 is a differential input to the MCP3905 device and is intended for the current-sensing channel of the energy meter. Channel 0 on this evaluation board contains resistor sockets for CT burden resistors, as well as a RC filter on each input, with the option of shorting either input to ground. Two examples of jumper configuration are given in Figure 2-8 and Figure 2-9.



**FIGURE 2-8:** Channel 0 Jumpers for 250 µΩ Shunt Selection.

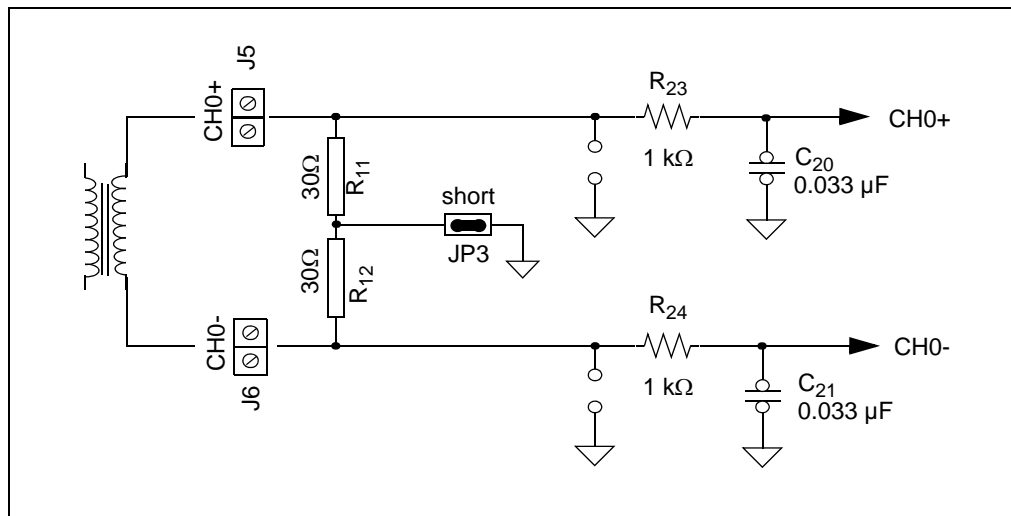
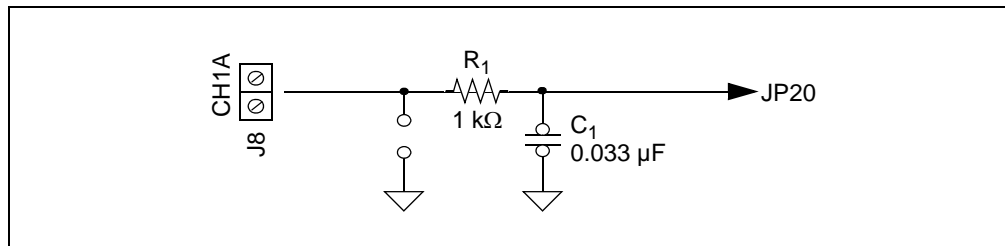

**FIGURE 2-9:** Example of Channel 0 Jumpers with 60Ω Burden Resistor for Connection to Current Transformer.



## 2.5.5 Channel 1 RC Circuit with A<sub>GND</sub> Option – Circuit A

Channel 1 is a differential input with two possible circuit selections for each single-ended input (circuit A and circuit B). Using the MCP3905/6 Evaluation Board, either of the inputs can be connected to the RC or to A<sub>GND</sub>, allowing single-ended or differential experiments. JPX should be shorted to ground for all single-ended input configurations.



**FIGURE 2-10:** Channel 1 RC Circuit A.

## 2.5.6 Channel 1 Voltage Divider Circuit and Calibration Potentiometer – Circuit B

Circuit B includes 4 resistor sockets and a mechanical potentiometer. This allows for experiments calibrating the output of the MCP3905 by changing Channel 1's input signal amplitude.

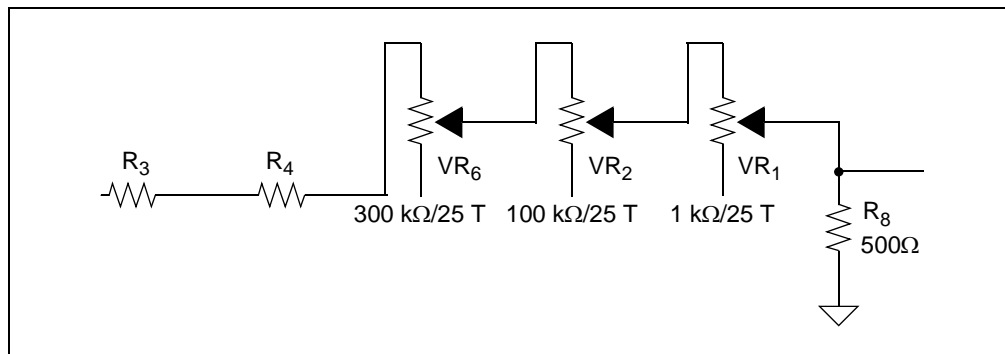

**FIGURE 2-11:** Voltage Divider on Channel 1 Including Potentiometers VR<sub>1</sub>, VR<sub>2</sub> and VR<sub>6</sub> for Calibration Experiments, Labeled Circuit B on the PCB Silk-Screen.

## 2.5.7 MCP3905

Center-of-board, 24-lead surface-mount package. Refer to the MCP3905 Data Sheet, “Energy Metering IC with Active Real Power Pulse Output” (DS21948) for a detailed description.

# MCP3905/6 Evaluation Board User's Guide

## 2.5.8 DC Power Supply

A low-cost DC power supply circuit is included on the MCP3905/6 Evaluation Board. This is the same DC power supply circuit used in the MCP3905/6 Energy Meter Reference Design. The DC power supply is created from a half-wave zener diode-limited AC signal feeding a 7805 +5V regulator.

$C_{17}$  and  $C_{16}$  divide the AC signal coming directly from the line, with their values depending on the AC source expected. The board comes populated with a series capacitor of 0.47  $\mu\text{F}$ , designed to divide down an AC line voltage of 220  $V_{\text{RMS}}$ . If the DC power supply is to be used with a 120  $V_{\text{RMS}}$  AC source capacitor,  $C_{16}$  should change to 1  $\mu\text{F}$ . Refer to **Appendix B. "Bill-Of-Materials (BOM)"** for detailed part information.

For more detail on this circuit design, as well as for 120V circuit specifications, refer to AN994 "IEC Compliant Active Energy Meter Design Using The MCP3905/6" (DS00994).

## 2.5.9 Output Prototype Area

A second prototype area is included for experiments using the MCP3905 output. All MCP3905 outputs ( $F_{\text{OUT}0}$ ,  $F_{\text{OUT}1}$ ,  $\text{HF}_{\text{OUT}}$ ,  $\text{REVP}$ ) are brought out to the prototype area.

## 2.5.10 Connecting the MCP3905/6 Evaluation Board to a PICDEM™ Demonstration Board

A standard 14-pin PICtail™ daughter board connector is included on this board, as shown in Figure 2-12. Any number of MCP3905 with PICmicro MCU meter designs can be developed. An optical isolator is included with the MCP3905/6 Energy Meter Reference Design as an additional level of protection for direct-connect meters using a shunt. It is connected to the selected output of the MCP3905 via JP5. A pull-up resistor is required on the output of the optical isolator to allow the selected logic signal to appear on the PICmicro MCU-based demo board, which is isolated entirely from the MCP3905/6 Evaluation Board. The output of the optical isolator is connected to RC0 on this connector, as shown in Figure 2-12. RC0 was chosen to be the default output due to the timer1 clock input on many PICmicro® MCUs.

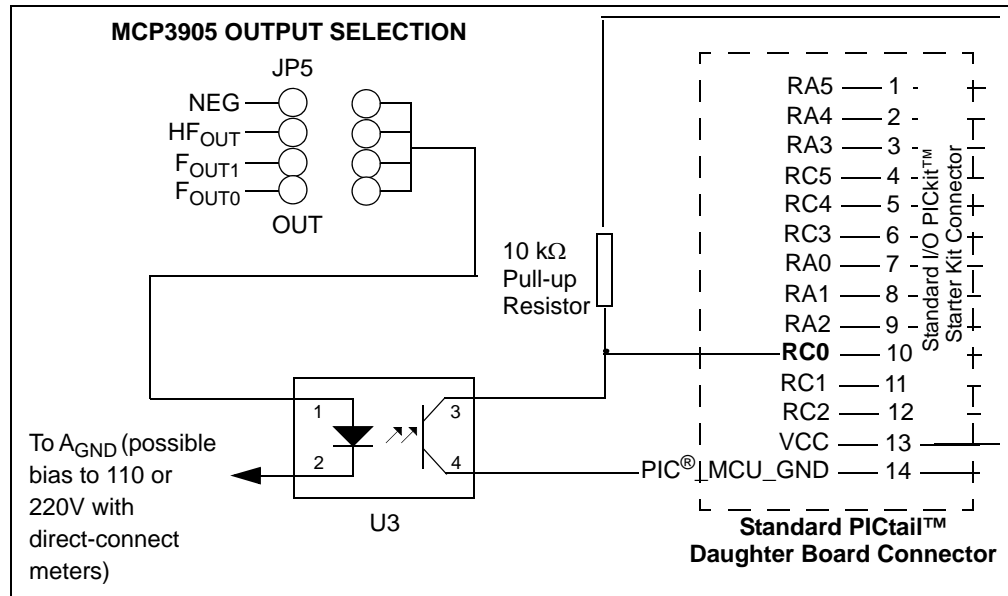

**FIGURE 2-12:** Optical isolation of the MCP3905 outputs to the PICkit™ header. The output is connected to RC0 using a 10 kΩ pull-up resistor to the PICtail™ daughter board header +5V and the PICmicro® MCU header, GND.

---

---

## Appendix A. Schematics and Layouts

---

---

### A.1 INTRODUCTION

This appendix contains the following schematics and layouts for the MCP3905/6 Evaluation Board User's Guide:

- Board Schematic
- Board – Top Layer and Silk-Screen
- Board – Bottom Layer

### A.2 SCHEMATICS AND PCB LAYOUT

The layer order is shown in Figure A-1.

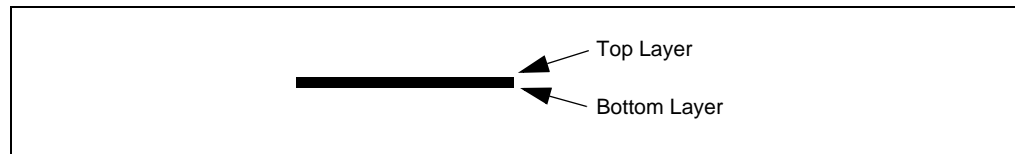

**FIGURE A-1:** *Layer Order*



## A.4 BOARD LAYOUT – TOP LAYER AND SILK-SCREEN

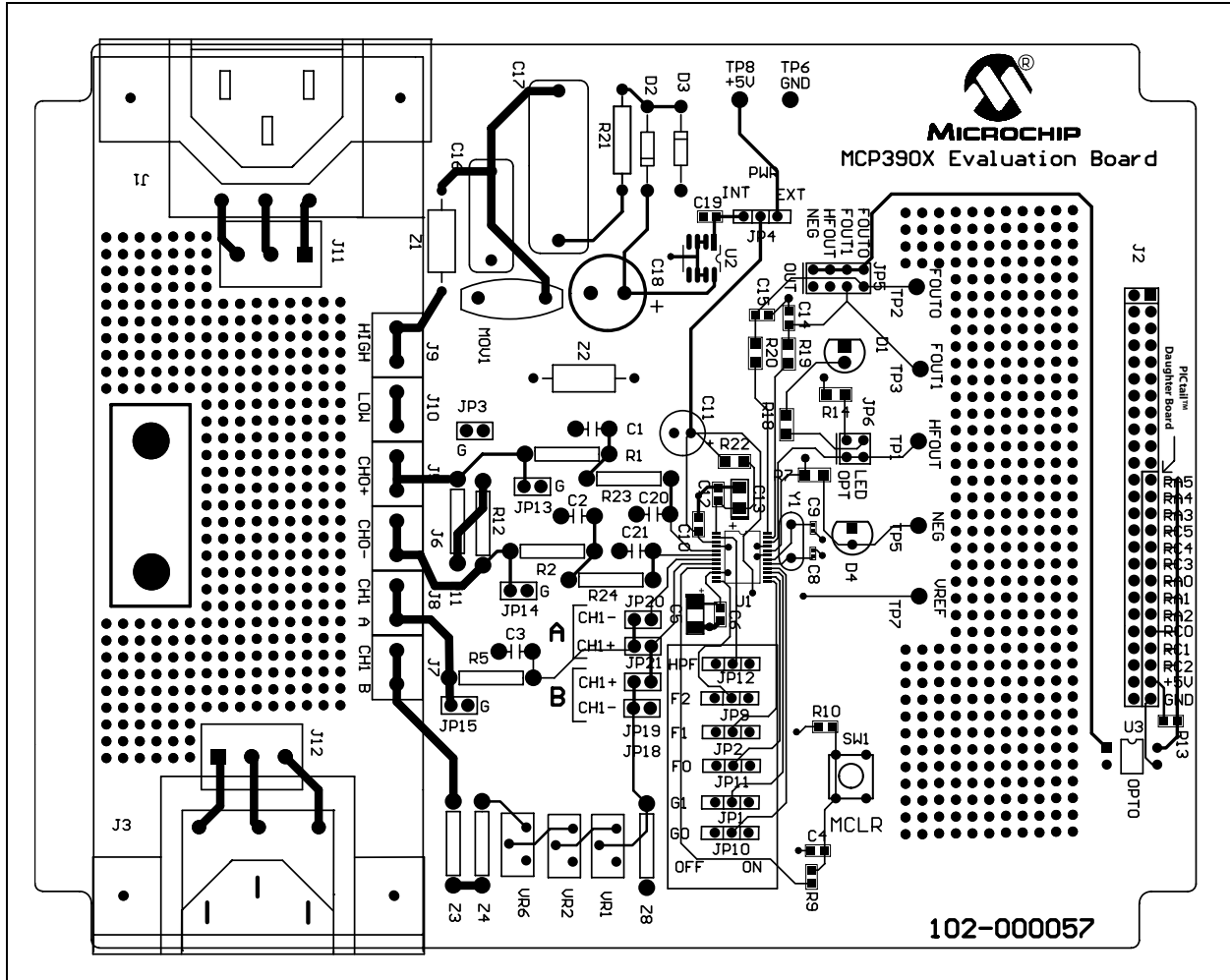

# MCP3905/6 Evaluation Board User's Guide

## A.5 BOARD LAYOUT – BOTTOM LAYER

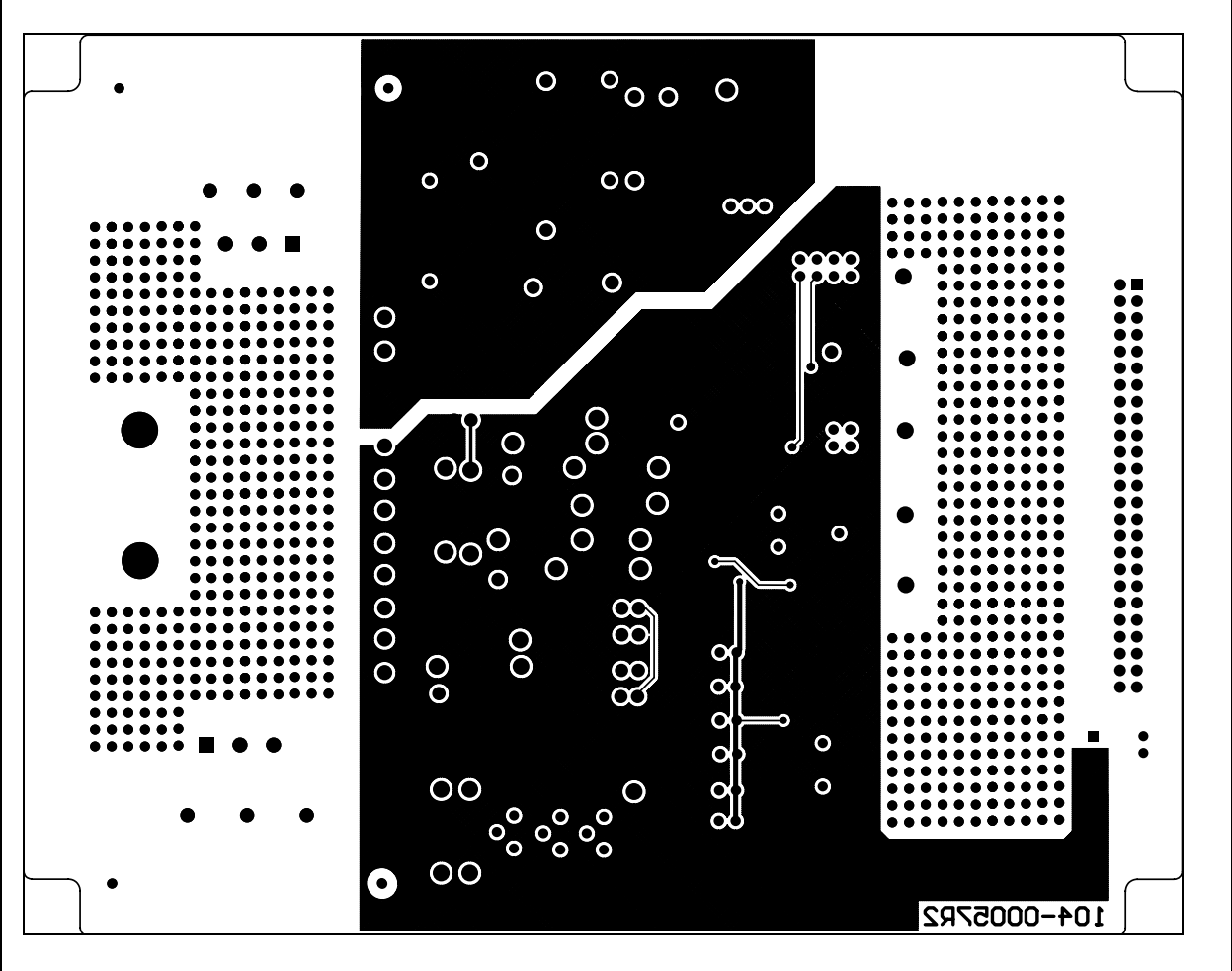

**Appendix B. Bill Of Materials (BOM)**

**TABLE B-1: BILL OF MATERIALS (BOM)**

Qty	Reference	Description	Manufacturer	Part Number
7	C4,C6,C10, C12,C14,C15, C19	CAP .1 $\mu$ F 16V CERAMIC X7R 0805	Panasonic <sup>®</sup> - ECG	ECJ-2VB1C104K
1	C16	01 $\mu$ F INTERFERFENCE METAL CAP	Panasonic - ECG	ECQ-U2A103MN
5	C1,C2,C3,C20, C21	CAP 33000PF 50V CERM X7R 0805	Panasonic - ECG	ECJ-2VB1H333K
1	C17	47UF/630VDC METAL POLY CAP	Panasonic - ECG	ECQ-E6474KF
1	C18	CAP 470 $\mu$ F 35V ELECT FC RADIAL	Panasonic - ECG	EEU-FC1V471
1	C22	CAP 220 $\mu$ F 10V ELECT FC RADIAL	Panasonic - ECG	EEU-FC1A221S
2	C8,C9	CAP 22PF 50V CERAMIC 0402 SMD	Panasonic - ECG	ECJ-0EC1H220J
2	C5,C13	CAP 10 $\mu$ F 6.3V TANT TE SERIES	Panasonic - ECG	ECS-T0JY106R
5	R1,R2,R5,R23, R24	RES 1.00K OHM 1/4W 1% METAL FILM	Yageo America	MFR-25FBF-1K00
1	R10	RES 4.75K OHM 1/10W 1% 0805 SMD	Panasonic - ECG	ERJ-6ENF4751V
1	R22	RES 10 OHM 1/8W 1% 1206 SMD	Panasonic - ECG	ERJ-8ENF10R0V
1	R13	RES 1.0K OHM 1/10W 1% 0805 SMD	Panasonic - ECG	ERJ-6ENF1001V
2	R19,R20	RES 20.0 OHM 1/8W 1% 1206 SMD	Panasonic - ECG	ERJ-8ENF20R0V
1	R9	RES 475 OHM 1/10W 1% 0805 SMD	Panasonic - ECG	ERJ-6ENF4750V
3	R7,R12,R14	RES 825 OHM 1/10W 1% 0805 SMD	Panasonic - ECG	ERJ-6ENF8250V
2	R11,R12	RES 30.1 OHM 1/4W 1% METAL FILM	Yageo America	MFR-25FBF-30R1
1	R21	RES 470 OHM 1W 5% METAL OXIDE	Panasonic - ECG	ERG-1SJ471
1	Z8	RES 499 OHM 1/4W 1% METAL FILM	Yageo America	MFR-25FBF-499R
2	Z3,Z4	RES 332K OHM 1/4W 1% METAL FILM	Yageo America	MFR-25FBF-332K
2	Z1,Z2	BEAD CORE SINGLE 3.5X9 MM AXIAL	Panasonic - ECG	EXC-ELSA39
1	VR1	POT 1.0K OHM 3/8" SQ CERM SL MT	Bourns <sup>®</sup> Inc.	3296Y-1-102
1	VR2	POT 100K OHM 3/8" SQ CERM SL MT	Bourns Inc.	3296Y-1-104
1	VR6	POT 500K OHM 3/8" SQ CERM SL MT	Bourns Inc.	3296Y-1-504
1	Y1	CRYSTAL 3.579545 MHZ 17PF HC49/US	ECS <sup>™</sup> Inc	ECS-35-17-4
1	J3	AC INPUT CONN	Schurter	GSP1.8101.1
1	J1	AC OUTPUT CONN	Schurter	4300.0251
1	J2	Not Installed	-	-
1	MOV1	Suppressor - Metal Oxide Varistor; Clamping Voltage Max. 710V; Peak Surge	Epcos	SIOV-S20K275
1	D1	LED GREEN DIFFUSED ROUND LONG	Panasonic - SSG	LN31GPH
1	D4	LED RED DIFFUSED ROUND LONG	Panasonic - SSG	LN21RPH
1	D2	RECTIFIER GPP 400V 1A DO-41	Diodes Inc	1N4004-T

# Bill Of Materials (BOM)

**TABLE B-1: BILL OF MATERIALS (BOM) (CONTINUED)**

Qty	Reference	Description	Manufacturer	Part Number
1	D3	DIODE ZENER 15V 1W 5% DO-41	Diodes Inc	1N4744A-T
1	U1	MCP3905 Energy Metering IC	Microchip Technology Inc.	MCP3905-I/SS
1	U2	IC VOLT REG 5V 100MA 8-SOIC	National Semiconductor™	LM78L05ACM
1	U3	1 CHANNEL OPTO COUPLER TRANS DIP	NEC	PS2501-1
1	SW1	SWITCH TACT 6MM MOM 100GF	Omron® Electronics Inc-ECB Div	B3F-1000
7	JP1,JP2,JP4 JP9,JP10,JP11 JP12	"HEADER, .1"ST MALE, 1RW, 3PIN, (10) .025"PST, .23"GOLDTAIL	Jameco Valuepro	7000-1X3SG
1	JP5	"HEADER, .1"ST MALE,2RW,8PIN, .025"PST,.23"GOLDTAIL (10)	Jameco Valuepro	0-2X4SG
1	JP6	"HEADER, ST MALE, 2RW, 4PIN, 1"CTR, .025 PST	Jameco Valuepro	2X2SG
10	JP3,JP16,JP15 JP13,JP14, JP18,JP20, JP21,JP19, JP17	"HEADER, .1"ST MALE, 1RW, 2PIN, (10) .025"PST, .21"GOLDTAIL	Jameco Valuepro	"7000-1X2SG "
6	TP1,TP2,TP3, TP5,TP7,TP6	TEST POINT PC MULTI PURPOSE WHT	Keystone Electronics®	5012
6	J5,J6,J7,J8 J9,J10	TERMINAL BLOCK 5 MM VERT 2POS PCB	Onshore Technology	ED350/2
2	J11,J12	TERMINAL BLOCK 5 MM VERT 3POS PCB	Onshore Technology	ED350/3
30	C1,C2,C3,C20,C 21,R1,R2,R5,R2 3,R24,Z3,Z4 Z8,R11,R12	PINRECPT .015/.025DIA0252SER Note* 2 Pins per Location	Mill-Max® Manufacturing Corp.	0252-0-15-01-3027100
4	J1 & J3	SCREW MACH PHIL 4-40X3/8 NYLON	Building Fasteners	NY PMS 440 0038 PH
4	J1 & J3	NUT HEX 4-40 NYLON	Building Fasteners	NY HN 440



# Bill Of Materials (BOM)

---

---

NOTES:



---

---

## WORLDWIDE SALES AND SERVICE

---

---

### AMERICAS

**Corporate Office**  
2355 West Chandler Blvd.  
Chandler, AZ 85224-6199  
Tel: 480-792-7200  
Fax: 480-792-7277  
Technical Support:  
<http://support.microchip.com>  
Web Address:  
[www.microchip.com](http://www.microchip.com)

**Atlanta**  
Alpharetta, GA  
Tel: 770-640-0034  
Fax: 770-640-0307

**Boston**  
Westborough, MA  
Tel: 774-760-0087  
Fax: 774-760-0088

**Chicago**  
Itasca, IL  
Tel: 630-285-0071  
Fax: 630-285-0075

**Dallas**  
Addison, TX  
Tel: 972-818-7423  
Fax: 972-818-2924

**Detroit**  
Farmington Hills, MI  
Tel: 248-538-2250  
Fax: 248-538-2260

**Kokomo**  
Kokomo, IN  
Tel: 765-864-8360  
Fax: 765-864-8387

**Los Angeles**  
Mission Viejo, CA  
Tel: 949-462-9523  
Fax: 949-462-9608

**San Jose**  
Mountain View, CA  
Tel: 650-215-1444  
Fax: 650-961-0286

**Toronto**  
Mississauga, Ontario,  
Canada  
Tel: 905-673-0699  
Fax: 905-673-6509

### ASIA/PACIFIC

**Australia - Sydney**  
Tel: 61-2-9868-6733  
Fax: 61-2-9868-6755

**China - Beijing**  
Tel: 86-10-8528-2100  
Fax: 86-10-8528-2104

**China - Chengdu**  
Tel: 86-28-8676-6200  
Fax: 86-28-8676-6599

**China - Fuzhou**  
Tel: 86-591-8750-3506  
Fax: 86-591-8750-3521

**China - Hong Kong SAR**  
Tel: 852-2401-1200  
Fax: 852-2401-3431

**China - Qingdao**  
Tel: 86-532-502-7355  
Fax: 86-532-502-7205

**China - Shanghai**  
Tel: 86-21-5407-5533  
Fax: 86-21-5407-5066

**China - Shenyang**  
Tel: 86-24-2334-2829  
Fax: 86-24-2334-2393

**China - Shenzhen**  
Tel: 86-755-8203-2660  
Fax: 86-755-8203-1760

**China - Shunde**  
Tel: 86-757-2839-5507  
Fax: 86-757-2839-5571

**China - Wuhan**  
Tel: 86-27-5980-5300  
Fax: 86-27-5980-5118

**China - Xian**  
Tel: 86-29-8833-7250  
Fax: 86-29-8833-7256

### ASIA/PACIFIC

**India - Bangalore**  
Tel: 91-80-2229-0061  
Fax: 91-80-2229-0062

**India - New Delhi**  
Tel: 91-11-5160-8631  
Fax: 91-11-5160-8632

**India - Pune**  
Tel: 91-20-2566-1512  
Fax: 91-20-2566-1513

**Japan - Yokohama**  
Tel: 81-45-471- 6166  
Fax: 81-45-471-6122

**Korea - Seoul**  
Tel: 82-2-554-7200  
Fax: 82-2-558-5932 or  
82-2-558-5934

**Malaysia - Penang**  
Tel: 604-646-8870  
Fax: 604-646-5086

**Philippines - Manila**  
Tel: 011-632-634-9065  
Fax: 011-632-634-9069

**Singapore**  
Tel: 65-6334-8870  
Fax: 65-6334-8850

**Taiwan - Hsinchu**  
Tel: 886-3-572-9526  
Fax: 886-3-572-6459

**Taiwan - Kaohsiung**  
Tel: 886-7-536-4818  
Fax: 886-7-536-4803

**Taiwan - Taipei**  
Tel: 886-2-2500-6610  
Fax: 886-2-2508-0102

**Thailand - Bangkok**  
Tel: 66-2-694-1351  
Fax: 66-2-694-1350

### EUROPE

**Austria - Weis**  
Tel: 43-7242-2244-399  
Fax: 43-7242-2244-393

**Denmark - Copenhagen**  
Tel: 45-4450-2828  
Fax: 45-4485-2829

**France - Paris**  
Tel: 33-1-69-53-63-20  
Fax: 33-1-69-30-90-79

**Germany - Munich**  
Tel: 49-89-627-144-0  
Fax: 49-89-627-144-44

**Italy - Milan**  
Tel: 39-0331-742611  
Fax: 39-0331-466781

**Netherlands - Drunen**  
Tel: 31-416-690399  
Fax: 31-416-690340

**Spain - Madrid**  
Tel: 34-91-352-30-52  
Fax: 34-91-352-11-47

**UK - Wokingham**  
Tel: 44-118-921-5869  
Fax: 44-118-921-5820

## X-ON Electronics

Largest Supplier of Electrical and Electronic Components

*Click to view similar products for [Power Management IC Development Tools](#) category:*

*Click to view products by [Microchip](#) manufacturer:*

Other Similar products are found below :

[EVB-EP5348UI](#) [MIC23451-AAAYFL EV](#) [MIC5281YMME EV](#) [124352-HMC860LP3E](#) [DA9063-EVAL](#) [ADP122-3.3-EVALZ](#) [ADP130-0.8-EVALZ](#) [ADP130-1.8-EVALZ](#) [ADP1740-1.5-EVALZ](#) [ADP1870-0.3-EVALZ](#) [ADP1874-0.3-EVALZ](#) [ADP199CB-EVALZ](#) [ADP2102-1.25-EVALZ](#) [ADP2102-1.875EVALZ](#) [ADP2102-1.8-EVALZ](#) [ADP2102-2-EVALZ](#) [ADP2102-3-EVALZ](#) [ADP2102-4-EVALZ](#) [AS3606-DB](#) [BQ25010EVM](#) [BQ3055EVM](#) [ISLUSBI2CKIT1Z](#) [LP38512TS-1.8EV](#) [EVAL-ADM1186-1MBZ](#) [EVAL-ADM1186-2MBZ](#) [ADP122UJZ-REDYKIT](#) [ADP166Z-REDYKIT](#) [ADP170-1.8-EVALZ](#) [ADP171-EVALZ](#) [ADP1853-EVALZ](#) [ADP1873-0.3-EVALZ](#) [ADP198CP-EVALZ](#) [ADP2102-1.0-EVALZ](#) [ADP2102-1-EVALZ](#) [ADP2107-1.8-EVALZ](#) [ADP5020CP-EVALZ](#) [CC-ACC-DBMX-51](#) [ATPL230A-EK](#) [MIC23250-S4YMT EV](#) [MIC26603YJL EV](#) [MIC33050-SYHL EV](#) [TPS60100EVM-131](#) [TPS65010EVM-230](#) [TPS71933-28EVM-213](#) [TPS72728YFFEVM-407](#) [TPS79318YEQEVM](#) [UCC28810EVM-002](#) [XILINXPWR-083](#) [LMR22007YMINI-EVM](#) [LP38501ATJ-EV](#)