

**MCP73855**  
**Evaluation Board**  
**User's Guide**

---

**Note the following details of the code protection feature on Microchip devices:**

- Microchip products meet the specification contained in their particular Microchip Data Sheet.
- Microchip believes that its family of products is one of the most secure families of its kind on the market today, when used in the intended manner and under normal conditions.
- There are dishonest and possibly illegal methods used to breach the code protection feature. All of these methods, to our knowledge, require using the Microchip products in a manner outside the operating specifications contained in Microchip's Data Sheets. Most likely, the person doing so is engaged in theft of intellectual property.
- Microchip is willing to work with the customer who is concerned about the integrity of their code.
- Neither Microchip nor any other semiconductor manufacturer can guarantee the security of their code. Code protection does not mean that we are guaranteeing the product as "unbreakable."

Code protection is constantly evolving. We at Microchip are committed to continuously improving the code protection features of our products. Attempts to break Microchip's code protection feature may be a violation of the Digital Millennium Copyright Act. If such acts allow unauthorized access to your software or other copyrighted work, you may have a right to sue for relief under that Act.

---

Information contained in this publication regarding device applications and the like is provided only for your convenience and may be superseded by updates. It is your responsibility to ensure that your application meets with your specifications. MICROCHIP MAKES NO REPRESENTATIONS OR WARRANTIES OF ANY KIND WHETHER EXPRESS OR IMPLIED, WRITTEN OR ORAL, STATUTORY OR OTHERWISE, RELATED TO THE INFORMATION, INCLUDING BUT NOT LIMITED TO ITS CONDITION, QUALITY, PERFORMANCE, MERCHANTABILITY OR FITNESS FOR PURPOSE. Microchip disclaims all liability arising from this information and its use. Use of Microchip's products as critical components in life support systems is not authorized except with express written approval by Microchip. No licenses are conveyed, implicitly or otherwise, under any Microchip intellectual property rights.

**Trademarks**

The Microchip name and logo, the Microchip logo, Accuron, dsPIC, KEELOQ, microID, MPLAB, PIC, PICmicro, PICSTART, PRO MATE, PowerSmart, rfPIC, and SmartShunt are registered trademarks of Microchip Technology Incorporated in the U.S.A. and other countries.

AmpLab, FilterLab, MXDEV, MXLAB, PICMASTER, SEEVAL, SmartSensor and The Embedded Control Solutions Company are registered trademarks of Microchip Technology Incorporated in the U.S.A.

Analog-for-the-Digital Age, Application Maestro, dsPICDEM, dsPICDEM.net, dsPICworks, ECAN, ECONOMONITOR, FanSense, FlexROM, fuzzyLAB, In-Circuit Serial Programming, ICSP, ICEPIC, Migratable Memory, MPASM, MPLIB, MPLINK, MPSIM, PICkit, PICDEM, PICDEM.net, PICLAB, PICTail, PowerCal, PowerInfo, PowerMate, PowerTool, rfLAB, rfPICDEM, Select Mode, Smart Serial, SmartTel and Total Endurance are trademarks of Microchip Technology Incorporated in the U.S.A. and other countries.

SQTP is a service mark of Microchip Technology Incorporated in the U.S.A.

All other trademarks mentioned herein are property of their respective companies.

© 2004, Microchip Technology Incorporated, Printed in the U.S.A., All Rights Reserved.

 Printed on recycled paper.

**QUALITY MANAGEMENT SYSTEM**  
**CERTIFIED BY DNV**  
**== ISO/TS 16949:2002 ==**

*Microchip received ISO/TS-16949:2002 quality system certification for its worldwide headquarters, design and wafer fabrication facilities in Chandler and Tempe, Arizona and Mountain View, California in October 2003. The Company's quality system processes and procedures are for its PICmicro® 8-bit MCUs, KEELOQ® code hopping devices, Serial EEPROMs, microperipherals, nonvolatile memory and analog products. In addition, Microchip's quality system for the design and manufacture of development systems is ISO 9001:2000 certified.*



# MCP73855 EVALUATION BOARD USER'S GUIDE

---

---

## Table of Contents

---

---

<b>Preface</b> .....	<b>1</b>
<b>Chapter 1. Product Overview</b> .....	<b>5</b>
1.1 Introduction and Highlights .....	5
1.2 What is the MCP73855 Evaluation Board? .....	5
1.3 What the MCP73855 Evaluation Board Kit Includes .....	5
<b>Chapter 2. MCP73855 Evaluation Board Installation</b> .....	<b>7</b>
2.1 Features .....	7
2.2 Getting Started .....	7
2.3 Detailed Description .....	8
<b>Appendix A. Schematic and Layouts</b> .....	<b>11</b>
A.1 Introduction .....	11
A.2 Board Schematic .....	12
A.3 Board - Assembly Drawing .....	13
A.4 Board - Top Layer .....	13
A.5 Board - Bottom Layer .....	14
<b>Appendix B. Bill-Of-Materials (BOM)</b> .....	<b>15</b>
<b>Worldwide Sales and Service</b> .....	<b>16</b>

# MCP73855 Evaluation Board User's Guide

---

NOTES:

---

---

**Preface**

---

---

**NOTICE TO CUSTOMERS**

All documentation becomes dated, and this manual is no exception. Microchip tools and documentation are constantly evolving to meet customer needs, so some actual dialogs and/or tool descriptions may differ from those in this document. Please refer to our web site ([www.microchip.com](http://www.microchip.com)) to obtain the latest documentation available.

Documents are identified with a “DS” number. This number is located on the bottom of each page, in front of the page number. The numbering convention for the DS number is “DSXXXXA”, where “XXXXX” is the document number and “A” is the revision level of the document.

For the most up-to-date information on development tools, see the MPLAB<sup>®</sup> IDE on-line help. Select the Help menu, and then Topics to open a list of available on-line help files.

**INTRODUCTION**

This chapter contains general information that will be useful to know before using the MCP73855 Evaluation Board. Items discussed in this chapter include:

- About This Guide
- Recommended Reading
- The Microchip Web Site
- Customer Support

# MCP73855 Evaluation Board User's Guide

---

## ABOUT THIS GUIDE

### Document Layout

This document describes how to use the MCP73855 Evaluation Board. The manual layout is as follows:

- **Chapter 1: Product Overview** – important information about the MCP73855 Evaluation Board.
- **Chapter 2: MCP73855 Evaluation Board Installation** – for users evaluating the MCP73855, this chapter describes how to use the various features of the hardware.
- **Appendix A: Schematic and Layouts** – shows the schematic and layout diagrams for the MCP73855 Evaluation Board.
- **Appendix B: Bill-of-Materials** – lists the parts used to build the MCP73855 Evaluation Board.

## Conventions Used in this Guide

This manual uses the following documentation conventions:

### DOCUMENTATION CONVENTIONS

Description	Represents	Examples
<b>Arial font:</b>		
Italic characters	Referenced books	<i>MPLAB<sup>®</sup> IDE User's Guide</i>
	Emphasized text	...is the <i>only</i> compiler...
Initial caps	A window	the Output window
	A dialog	the Settings dialog
	A menu selection	select Enable Programmer
Quotes	A field name in a window or dialog	"Save project before build"
Underlined, italic text with right angle bracket	A menu path	<u><i>File&gt;Save</i></u>
Bold characters	A dialog button	Click <b>OK</b>
	A tab	Click the <b>Power</b> tab
'bnnnn	A binary number where <i>n</i> is a digit	'b00100, 'b10
Text in angle brackets < >	A key on the keyboard	Press <Enter>, <F1>
<b>Courier font:</b>		
Plain Courier	Sample source code	#define START
	Filenames	autoexec.bat
	File paths	c:\mcc18\h
	Keywords	_asm, _endasm, static
	Command-line options	-Opa+, -Opa-
	Bit values	0, 1
Italic Courier	A variable argument	<i>file.o</i> , where <i>file</i> can be any valid filename
0xnnnn	A hexadecimal number where <i>n</i> is a hexadecimal digit	0xFFFF, 0x007A
Square brackets [ ]	Optional arguments	mcc18 [options] <i>file</i> [options]
Curly brackets and pipe character: {   }	Choice of mutually exclusive arguments; an OR selection	errorlevel {0 1}
Ellipses...	Replaces repeated text	var_name [, var_name...]
	Represents code supplied by user	void main (void) { ... }

# MCP73855 Evaluation Board User's Guide

---

## RECOMMENDED READING

This user's guide describes how to use the MCP73855 Evaluation Board. Other useful documents are listed below. The following Microchip documents are available and recommended as supplemental reference resources.

### **MCP73853/55 Data Sheet (DS21915)**

This data sheet provides detailed information regarding the MCP7385X devices.

## THE MICROCHIP WEB SITE

Microchip provides online support via our web site at [www.microchip.com](http://www.microchip.com). This web site is used as a means to make files and information easily available to customers. Accessible by using your favorite Internet browser, the web site contains the following information:

- **Product Support** – Data sheets and errata, application notes and sample programs, design resources, user's guides and hardware support documents, latest software releases and archived software
- **General Technical Support** – Frequently Asked Questions (FAQ), technical support requests, online discussion groups, Microchip consultant program member listing
- **Business of Microchip** – Product selector and ordering guides, latest Microchip press releases, listing of seminars and events, listings of Microchip sales offices, distributors and factory representatives

## CUSTOMER SUPPORT

Users of Microchip products can receive assistance through several channels:

- Distributor or Representative
- Local Sales Office
- Field Application Engineer (FAE)
- Technical Support
- Development Systems Information Line

Customers should contact their distributor, representative or field application engineer (FAE) for support. Local sales offices are also available to help customers. A listing of sales offices and locations is included in the back of this document.

Technical support is available through the web site at: <http://support.microchip.com>

In addition, there is a Development Systems Information Line which lists the latest versions of Microchip's development systems software products. This line also provides information on how customers can receive currently available upgrade kits.

The Development Systems Information Line numbers are:

1-800-755-2345 – United States and most of Canada

1-480-792-7302 – Other International Locations



---

---

## **Chapter 1. Product Overview**

---

---

### **1.1 INTRODUCTION AND HIGHLIGHTS**

This chapter provides an overview of the MCP73855 Evaluation Board and covers the following topics:

- What is the MCP73855 Evaluation Board?
- What the MCP73855 Evaluation Board Kit Includes

### **1.2 WHAT IS THE MCP73855 EVALUATION BOARD?**

The MCP73855 Evaluation Board is an evaluation and demonstration tool for Microchip Technology's MCP73855 USB Compatible Li-Ion/Li-Polymer Charge Management Controller. The design provides for dynamic versatility while being able to handle accurate measurements.

The MCP73855 Evaluation Board allows for the evaluation of the MCP73855 device in a variety of applications.

### **1.3 WHAT THE MCP73855 EVALUATION BOARD KIT INCLUDES**

This MCP73855 Evaluation Board Kit includes:

- The MCP73855 Evaluation Board (102-00040)
- MCP73855 Device (Installed)
- MCP73853/55 Data Sheet (DS21915)
- MCP73855 Evaluation Board User's Guide (DS51522)

# MCP73855 Evaluation Board User's Guide

---

NOTES:

---

---

**Chapter 2. MCP73855 Evaluation Board Installation**

---

---

**2.1 FEATURES**

The MCP73855 Evaluation Board has the following features:

- Evaluation of the MCP73855 USB Compatible Li-Ion/Li-Polymer Charge Management Controller in a 3mm x 3mm, 10-Lead DFN Package
- Simple, stand-alone operation or microcontroller-compatible
- Powered from external bench supply, wall cube or USB port
- Surface-mount design
- Fully assembled and tested

**2.2 GETTING STARTED**

The MCP73855 Evaluation Board is a fully-functional, assembled and tested, surface-mount board used for evaluation of Microchip's MCP73855 USB Compatible Li-Ion/Li-Polymer Charge Management Controller. The following steps provide simple, stand-alone operation. Refer to Figure 2-1 for the setup configuration diagram. The setup configuration diagram depicts evaluation of the installed MCP73855 for single-cell applications.

1. Connect an external bench supply, wall cube or USB port to the surface-mount test points provided. The input voltage source should be in the range of 4.5V to 5.5V. Refer to **Section 2.3.1 "Input Source"** for details on the input source requirements.

**Note:** Observe correct polarity of connection. Positive terminal connects to J2,  $V_{IN+}$ ; negative terminal connects to J3,  $V_{IN-}$ .

2. Connect a single-cell Li-Ion or Li-Polymer battery pack to the circuit for evaluation.

**Note:** Observe correct polarity of connection. Positive terminal connects to J5,  $V_{BAT+}$ ; negative terminal connects to J6,  $V_{BAT-}$ .

3. Turn on the bench supply or plug in the wall cube/USB port.
4. A green LED ( $D_1$ ) provides status during the charge cycle. Refer to the MCP73853/55 data sheet (DS21915) for details.

# MCP73855 Evaluation Board User's Guide

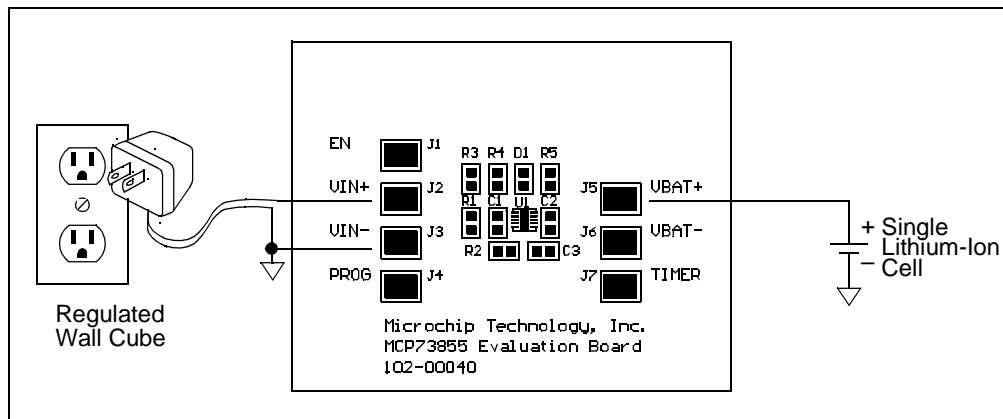

**FIGURE 2-1:** Setup Configuration Diagram.

## 2.3 DETAILED DESCRIPTION

The MCP73855 Evaluation Board is set-up to evaluate simple, stand-alone, linear charging of single-cell Li-Ion/Li-Polymer battery packs. The reference design provides constant current charging followed by constant voltage charging with automatic charge termination. As provided, the MCP73855 Evaluation Board is set for fast charge constant current levels of 85 mA with J4 (PROG) open and 400 mA with J4 (PROG) connected to J3 ( $V_{IN-}$ ). The MCP73855 is provided in a 3 mm X 3 mm, 10-lead DFN package and is equipped with shutdown control, status indicator and safety timer. Refer to the MCP73853/55 data sheet (DS21915) for details on individual device features.

### 2.3.1 Input Source

The MCP73855 Evaluation Board is designed to provide a fast charge current up to 400 mA, typically. The input source should provide a voltage in the range of 4.5V to 5.5V. The input source should be capable of providing a minimum of 2.5W.

Charge currents between 85 mA and 400 mA can be obtained by adjusting the value of the charge programming resistors ( $R_2$ ) and connecting surface-mount test point J4 (PROG) to J3 ( $V_{IN-}$ ). Refer to the MCP73853/55 data sheet (DS21915) for details on determining the appropriate programming resistor.

### 2.3.2 Safety Timer Periods

The MCP73855 Evaluation Board can be used with a variety of battery packs. As provided, the MCP73855 Evaluation Board is set up to perform well with single-cell, 100 mAh to 500 mAh battery packs. Battery packs with alternative capacities and various charge currents can be implemented. The safety timer periods may need to be adjusted in order to ensure a full charge. The safety timer periods can be adjusted by changing the capacitance of  $C_3$ . Refer to the MCP73853/55 data sheet (DS21915) for details on determining the appropriate timer capacitance.

### 2.3.3 Disable Control

The MCP73855 Evaluation Board is designed to provide stand-alone operation. The installed MCP73855 device is enabled whenever the input source is present. To disable charging, a jumper can be placed between J1 (EN) and J3 ( $V_{IN-}$ ).

## 2.3.4 Battery Headers

Independent battery connections are provided. The battery pack positive terminal should be connected to J5 ( $V_{BAT+}$ ). The battery pack's negative terminal should be connected to J6 ( $V_{BAT-}$ ).

<p><b>Note:</b> Improper connection of the battery may result in damage to the battery and the possibility of personal injury. It is also important to avoid shorting the battery terminals together.</p>
-----------------------------------------------------------------------------------------------------------------------------------------------------------------------------------------------------------

## 2.3.5 Device Support Options

The MCP73855 Evaluation Board supports the MCP73855 device. The MCP73855 Evaluation Board is provided with one reference design utilizing the MCP73855.

## 2.3.6 Microcontroller option

Connection points provide easily accessible locations for interface to a host microcontroller. The host microcontroller can be used to disable the charger, monitor charge status or terminate a charge.

## 2.3.7 Output voltage options

The MCP73855 Evaluation Board is provided with a Constant-voltage mode output voltage of 4.2V. Evaluation with a Constant-voltage mode output voltage of 4.1V can be achieved by moving resistor  $R_4$  to  $R_3$ , or by shorting the  $R_3$  pads.

# MCP73855 Evaluation Board User's Guide

---

NOTES:



# MCP73855 EVALUATION BOARD USER'S GUIDE

---

---

## Appendix A. Schematic and Layouts

---

---

### A.1 INTRODUCTION

This appendix contains the following schematics and layout diagrams for the MCP73855 Evaluation Board.

Diagrams included in this appendix:

- Board Schematic
- Board - Assembly Drawing
- Board - Top Layer
- Board - Bottom Layer

# MCP73855 Evaluation Board User's Guide

## A.2 BOARD SCHEMATIC

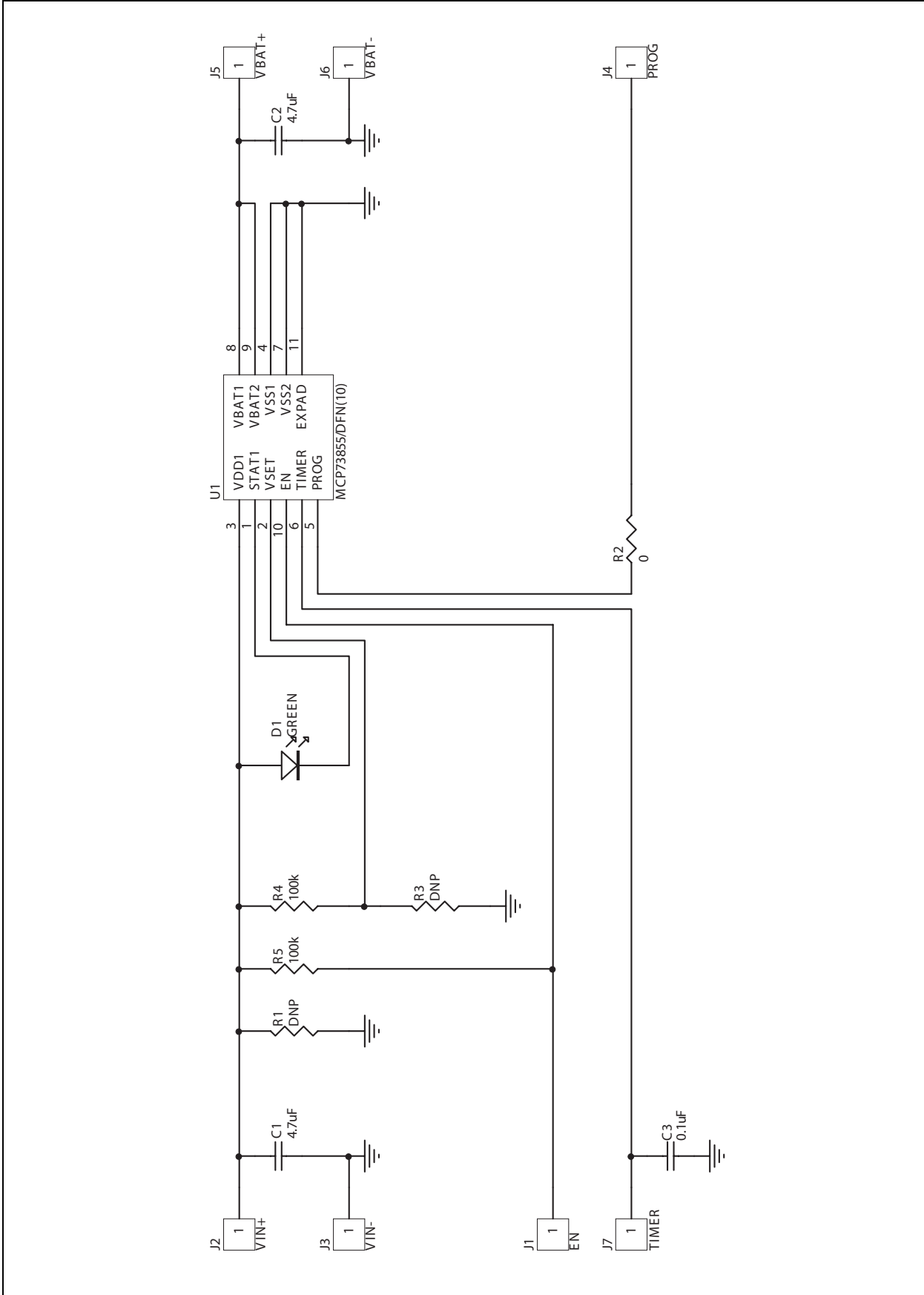



### A.3 BOARD - ASSEMBLY DRAWING

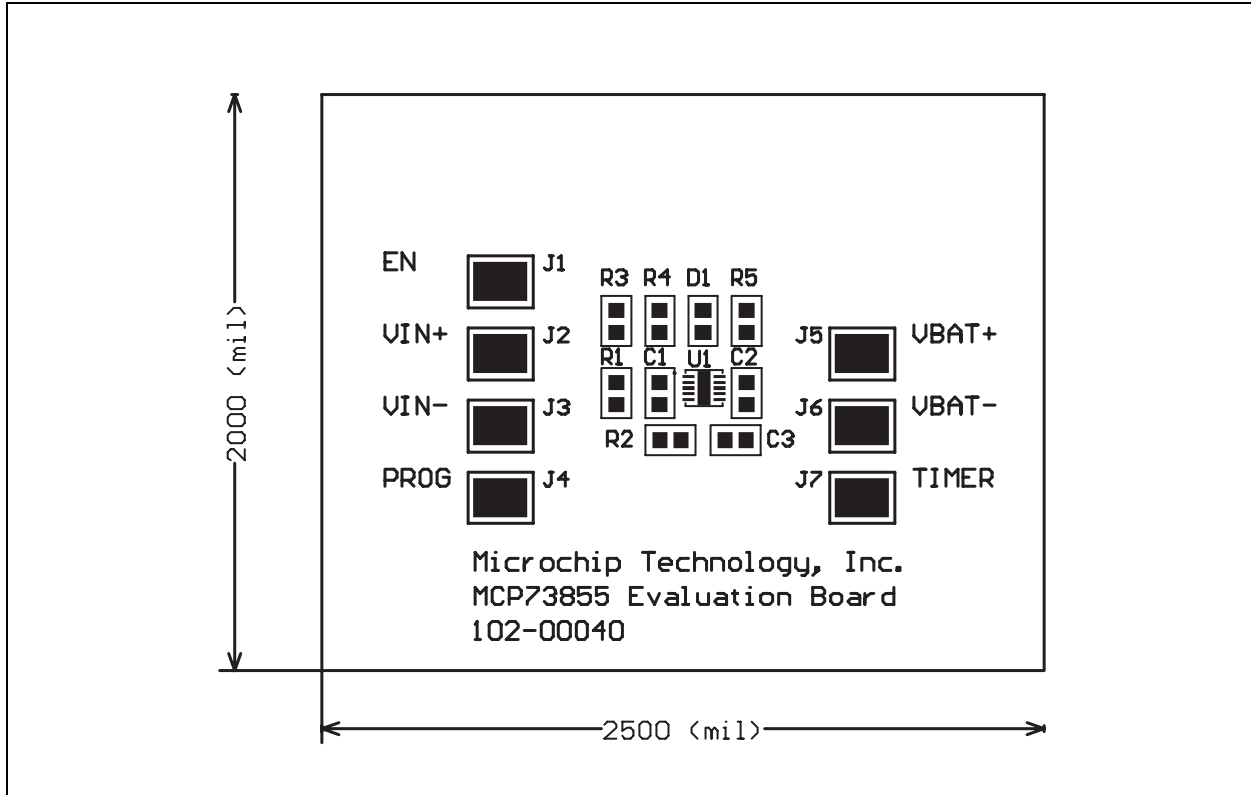

### A.4 BOARD - TOP LAYER

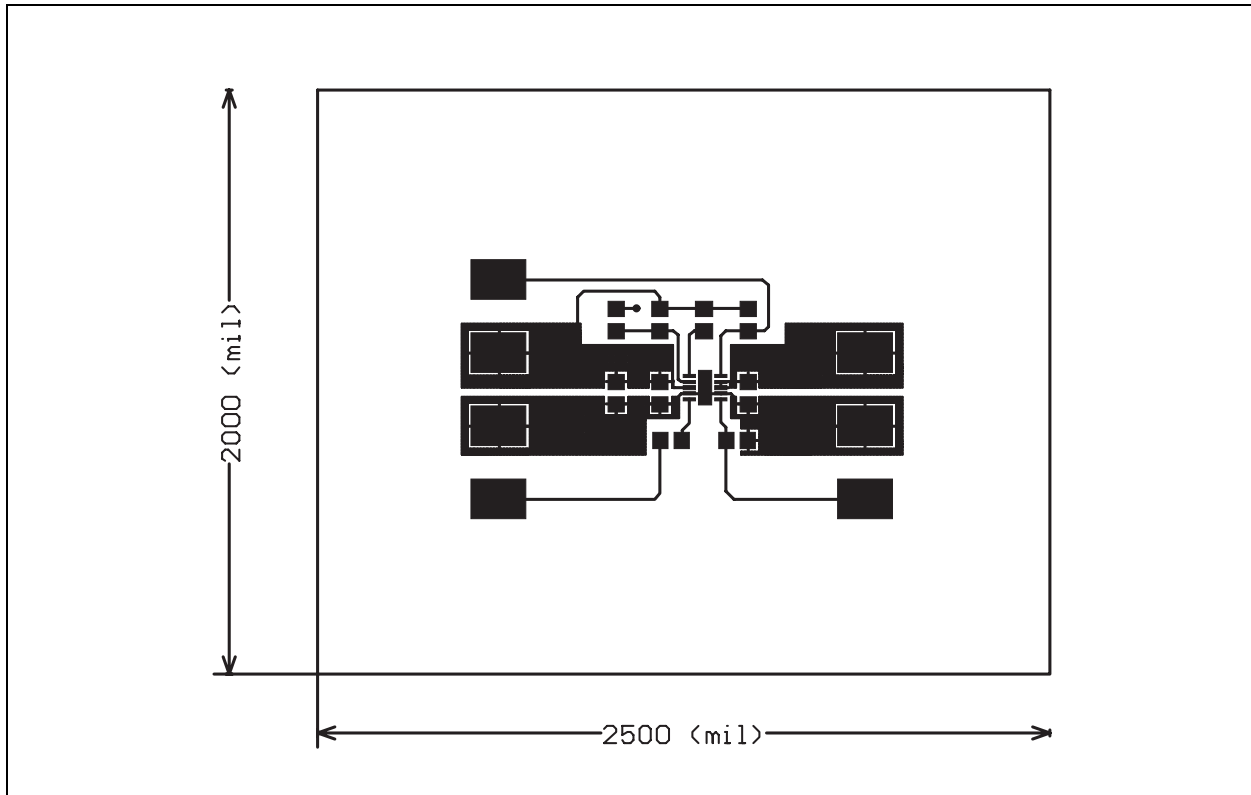

# MCP73855 Evaluation Board User's Guide

---

## A.5 BOARD - BOTTOM LAYER

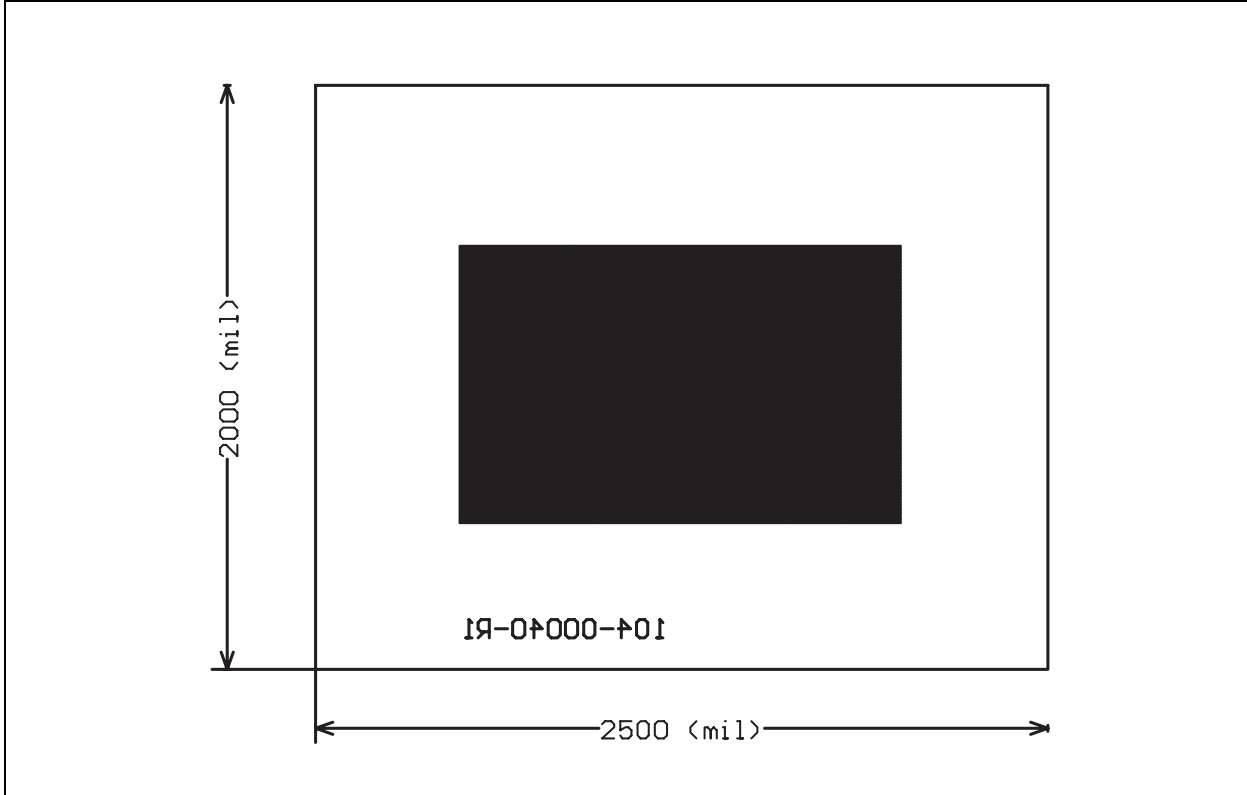

**Appendix B. Bill-Of-Materials (BOM)**

**TABLE B-1: BILL-OF-MATERIALS (BOM)**

Qty	Reference Designator	Description	Manufacturer	Part Number
2	C1, C2	4.7 uF, X5R Ceramic, 16V, 0805	Panasonic <sup>®</sup>	ECJ-2FB1C475K
1	C3	0.1 uF, X7R Ceramic, 16V, 0805	Panasonic	ECJ-2VB1C104K
1	D1	Green LED, 0805	Lumex <sup>®</sup>	SML-LXT0805GW
7	J1 - J7	Surface Mount Test Point, 5016	Keystone Electronics <sup>®</sup>	5016
0	R1, R3	Do Not Populate, 0805	—	—
1	R2	0 ohm Jumper, 0805	Panasonic	ERJ-6GEY0R00V
2	R4, R5	100 kΩ, 1/10W, Chip Resistor, 0805	Panasonic	ERJ-6ENF1003V
1	U1	USB Compatible Charge Controller, 3X3DFN10	Microchip Technology Inc.	MCP73855-I/MF



---

---

## WORLDWIDE SALES AND SERVICE

---

---

### AMERICAS

**Corporate Office**  
2355 West Chandler Blvd.  
Chandler, AZ 85224-6199  
Tel: 480-792-7200  
Fax: 480-792-7277  
Technical Support:  
<http://support.microchip.com>  
Web Address:  
[www.microchip.com](http://www.microchip.com)

#### Atlanta

Alpharetta, GA  
Tel: 770-640-0034  
Fax: 770-640-0307

#### Boston

Westford, MA  
Tel: 978-692-3848  
Fax: 978-692-3821

#### Chicago

Itasca, IL  
Tel: 630-285-0071  
Fax: 630-285-0075

#### Dallas

Addison, TX  
Tel: 972-818-7423  
Fax: 972-818-2924

#### Detroit

Farmington Hills, MI  
Tel: 248-538-2250  
Fax: 248-538-2260

#### Kokomo

Kokomo, IN  
Tel: 765-864-8360  
Fax: 765-864-8387

#### Los Angeles

Mission Viejo, CA  
Tel: 949-462-9523  
Fax: 949-462-9608

#### San Jose

Mountain View, CA  
Tel: 650-215-1444  
Fax: 650-961-0286

#### Toronto

Mississauga, Ontario,  
Canada  
Tel: 905-673-0699  
Fax: 905-673-6509

### ASIA/PACIFIC

**Australia - Sydney**  
Tel: 61-2-9868-6733  
Fax: 61-2-9868-6755

**China - Beijing**  
Tel: 86-10-8528-2100  
Fax: 86-10-8528-2104

**China - Chengdu**  
Tel: 86-28-8676-6200  
Fax: 86-28-8676-6599

**China - Fuzhou**  
Tel: 86-591-8750-3506  
Fax: 86-591-8750-3521

**China - Hong Kong SAR**  
Tel: 852-2401-1200  
Fax: 852-2401-3431

**China - Shanghai**  
Tel: 86-21-5407-5533  
Fax: 86-21-5407-5066

**China - Shenyang**  
Tel: 86-24-2334-2829  
Fax: 86-24-2334-2393

**China - Shenzhen**  
Tel: 86-755-8203-2660  
Fax: 86-755-8203-1760

**China - Shunde**  
Tel: 86-757-2839-5507  
Fax: 86-757-2839-5571

**China - Qingdao**  
Tel: 86-532-502-7355  
Fax: 86-532-502-7205

### ASIA/PACIFIC

**India - Bangalore**  
Tel: 91-80-2229-0061  
Fax: 91-80-2229-0062

**India - New Delhi**  
Tel: 91-11-5160-8631  
Fax: 91-11-5160-8632

**Japan - Kanagawa**  
Tel: 81-45-471-6166  
Fax: 81-45-471-6122

**Korea - Seoul**  
Tel: 82-2-554-7200  
Fax: 82-2-558-5932 or  
82-2-558-5934

**Singapore**  
Tel: 65-6334-8870  
Fax: 65-6334-8850

**Taiwan - Kaohsiung**  
Tel: 886-7-536-4818  
Fax: 886-7-536-4803

**Taiwan - Taipei**  
Tel: 886-2-2500-6610  
Fax: 886-2-2508-0102

**Taiwan - Hsinchu**  
Tel: 886-3-572-9526  
Fax: 886-3-572-6459

### EUROPE

**Austria - Weis**  
Tel: 43-7242-2244-399  
Fax: 43-7242-2244-393

**Denmark - Ballerup**  
Tel: 45-4450-2828  
Fax: 45-4485-2829

**France - Massy**  
Tel: 33-1-69-53-63-20  
Fax: 33-1-69-30-90-79

**Germany - Ismaning**  
Tel: 49-89-627-144-0  
Fax: 49-89-627-144-44

**Italy - Milan**  
Tel: 39-0331-742611  
Fax: 39-0331-466781

**Netherlands - Drunen**  
Tel: 31-416-690399  
Fax: 31-416-690340

**England - Berkshire**  
Tel: 44-118-921-5869  
Fax: 44-118-921-5820

## X-ON Electronics

Largest Supplier of Electrical and Electronic Components

*Click to view similar products for [Power Management IC Development Tools](#) category:*

*Click to view products by [Microchip](#) manufacturer:*

Other Similar products are found below :

[EVB-EP5348UI](#) [MIC23451-AAAYFL EV](#) [MIC5281YMME EV](#) [124352-HMC860LP3E](#) [DA9063-EVAL](#) [ADP122-3.3-EVALZ](#) [ADP130-0.8-EVALZ](#) [ADP130-1.8-EVALZ](#) [ADP1740-1.5-EVALZ](#) [ADP1870-0.3-EVALZ](#) [ADP1874-0.3-EVALZ](#) [ADP199CB-EVALZ](#) [ADP2102-1.25-EVALZ](#) [ADP2102-1.875EVALZ](#) [ADP2102-1.8-EVALZ](#) [ADP2102-2-EVALZ](#) [ADP2102-3-EVALZ](#) [ADP2102-4-EVALZ](#) [AS3606-DB](#) [BQ25010EVM](#) [BQ3055EVM](#) [ISLUSBI2CKIT1Z](#) [LP38512TS-1.8EV](#) [EVAL-ADM1186-1MBZ](#) [EVAL-ADM1186-2MBZ](#) [ADP122UJZ-REDYKIT](#) [ADP166Z-REDYKIT](#) [ADP170-1.8-EVALZ](#) [ADP171-EVALZ](#) [ADP1853-EVALZ](#) [ADP1873-0.3-EVALZ](#) [ADP198CP-EVALZ](#) [ADP2102-1.0-EVALZ](#) [ADP2102-1-EVALZ](#) [ADP2107-1.8-EVALZ](#) [ADP5020CP-EVALZ](#) [CC-ACC-DBMX-51](#) [ATPL230A-EK](#) [MIC23250-S4YMT EV](#) [MIC26603YJL EV](#) [MIC33050-SYHL EV](#) [TPS60100EVM-131](#) [TPS65010EVM-230](#) [TPS71933-28EVM-213](#) [TPS72728YFFEVM-407](#) [TPS79318YEQEVM](#) [UCC28810EVM-002](#) [XILINXPWR-083](#) [LMR22007YMINI-EVM](#) [LP38501ATJ-EV](#)