



MCP73871
Evaluation Board
User's Guide

Note the following details of the code protection feature on Microchip devices:

- Microchip products meet the specification contained in their particular Microchip Data Sheet.
- Microchip believes that its family of products is one of the most secure families of its kind on the market today, when used in the intended manner and under normal conditions.
- There are dishonest and possibly illegal methods used to breach the code protection feature. All of these methods, to our knowledge, require using the Microchip products in a manner outside the operating specifications contained in Microchip's Data Sheets. Most likely, the person doing so is engaged in theft of intellectual property.
- Microchip is willing to work with the customer who is concerned about the integrity of their code.
- Neither Microchip nor any other semiconductor manufacturer can guarantee the security of their code. Code protection does not mean that we are guaranteeing the product as "unbreakable."

Code protection is constantly evolving. We at Microchip are committed to continuously improving the code protection features of our products. Attempts to break Microchip's code protection feature may be a violation of the Digital Millennium Copyright Act. If such acts allow unauthorized access to your software or other copyrighted work, you may have a right to sue for relief under that Act.

Information contained in this publication regarding device applications and the like is provided only for your convenience and may be superseded by updates. It is your responsibility to ensure that your application meets with your specifications. MICROCHIP MAKES NO REPRESENTATIONS OR WARRANTIES OF ANY KIND WHETHER EXPRESS OR IMPLIED, WRITTEN OR ORAL, STATUTORY OR OTHERWISE, RELATED TO THE INFORMATION, INCLUDING BUT NOT LIMITED TO ITS CONDITION, QUALITY, PERFORMANCE, MERCHANTABILITY OR FITNESS FOR PURPOSE. Microchip disclaims all liability arising from this information and its use. Use of Microchip devices in life support and/or safety applications is entirely at the buyer's risk, and the buyer agrees to defend, indemnify and hold harmless Microchip from any and all damages, claims, suits, or expenses resulting from such use. No licenses are conveyed, implicitly or otherwise, under any Microchip intellectual property rights.

Trademarks

The Microchip name and logo, the Microchip logo, Accuron, dsPIC, KEELOQ, KEELOQ logo, MPLAB, PIC, PICmicro, PICSTART, rPIC and SmartShunt are registered trademarks of Microchip Technology Incorporated in the U.S.A. and other countries.

FilterLab, Linear Active Thermistor, MXDEV, MXLAB, SEEVAL, SmartSensor and The Embedded Control Solutions Company are registered trademarks of Microchip Technology Incorporated in the U.S.A.

Analog-for-the-Digital Age, Application Maestro, CodeGuard, dsPICDEM, dsPICDEM.net, dsPICworks, dsSPEAK, ECAN, ECONOMONITOR, FanSense, In-Circuit Serial Programming, ICSP, ICEPIC, Mindi, MiWi, MPASM, MPLAB Certified logo, MPLIB, MPLINK, mTouch, PICkit, PICDEM, PICDEM.net, PICTail, PIC³² logo, PowerCal, PowerInfo, PowerMate, PowerTool, REAL ICE, rLAB, Select Mode, Total Endurance, UNI/O, WiperLock and ZENA are trademarks of Microchip Technology Incorporated in the U.S.A. and other countries.

SQTP is a service mark of Microchip Technology Incorporated in the U.S.A.

All other trademarks mentioned herein are property of their respective companies.

© 2008, Microchip Technology Incorporated, Printed in the U.S.A., All Rights Reserved.

 Printed on recycled paper.

**QUALITY MANAGEMENT SYSTEM
CERTIFIED BY DNV
== ISO/TS 16949:2002 ==**

Microchip received ISO/TS-16949:2002 certification for its worldwide headquarters, design and wafer fabrication facilities in Chandler and Tempe, Arizona; Gresham, Oregon and design centers in California and India. The Company's quality system processes and procedures are for its PIC[®] MCUs and dsPIC[®] DSCs, KEELOQ[®] code hopping devices, Serial EEPROMs, microperipherals, nonvolatile memory and analog products. In addition, Microchip's quality system for the design and manufacture of development systems is ISO 9001:2000 certified.



MCP73871 EVALUATION BOARD USER'S GUIDE

Table of Contents

Preface	1
Introduction.....	1
Document Layout	1
Conventions Used in this Guide	2
Recommended Reading.....	2
The Microchip Web Site	3
Customer Support	3
Document Revision History	3
Chapter 1. Product Overview	
1.1 Introduction	5
1.2 What is the MCP73871 Evaluation Board?	6
1.3 What the MCP73871 Evaluation Board Kit includes	6
Chapter 2. Installation and Operation	
2.1 Introduction	7
2.2 Features	7
2.3 Getting Started	8
Appendix A. Schematic and Layouts	
A.1 Introduction	11
A.2 Board – Schematic	12
A.3 Board – Top Layer	13
A.4 Board – Top Metal Layer	13
A.5 Board – Bottom Layer	14
Appendix B. Bill Of Materials (BOM)	
Worldwide Sales and Service	16

MCP73871 Evaluation Board User's Guide

NOTES:



MCP73871 EVALUATION BOARD USER'S GUIDE

Preface

NOTICE TO CUSTOMERS

All documentation becomes dated, and this manual is no exception. Microchip tools and documentation are constantly evolving to meet customer needs, so some actual dialogs and/or tool descriptions may differ from those in this document. Please refer to our web site (www.microchip.com) to obtain the latest documentation available.

Documents are identified with a "DS" number. This number is located on the bottom of each page, in front of the page number. The numbering convention for the DS number is "DSXXXXA", where "XXXX" is the document number and "A" is the revision level of the document.

For the most up-to-date information on development tools, see the MPLAB® IDE on-line help. Select the Help menu, and then Topics to open a list of available on-line help files.

INTRODUCTION

This chapter contains general information that will be useful to know before using the MCP73871 Evaluation Board User's Guide. Items discussed in this chapter include:

- Document Layout
- Conventions Used in this Guide
- Recommended Reading
- The Microchip Web Site
- Customer Support
- Document Revision History

DOCUMENT LAYOUT

This document describes how to use the MCP73871 Evaluation Board User's Guide as a development tool to emulate and debug firmware on a target board. The manual layout is as follows:

- **Chapter 1. "Product Overview"** – Important information about the MCP73871 Evaluation Board User's Guide.
- **Chapter 2. "Installation and Operation"** – Includes instructions on how to get started with this user's guide and a description of the user's guide.
- **Appendix A. "Schematic and Layouts"** – Shows the schematic and layout diagrams for the MCP73871 Evaluation Board User's Guide.
- **Appendix B. "Bill Of Materials (BOM)"** – Lists the parts used to build the MCP73871 Evaluation Board User's Guide.

MCP73871 Evaluation Board User's Guide

CONVENTIONS USED IN THIS GUIDE

This manual uses the following documentation conventions:

DOCUMENTATION CONVENTIONS

Description	Represents	Examples
Arial font:		
Italic characters	Referenced books	<i>MPLAB® IDE User's Guide</i>
	Emphasized text	...is the <i>only</i> compiler...
Initial caps	A window	the Output window
	A dialog	the Settings dialog
	A menu selection	select Enable Programmer
Quotes	A field name in a window or dialog	"Save project before build"
Underlined, italic text with right angle bracket	A menu path	<u><i>File>Save</i></u>
Bold characters	A dialog button	Click OK
	A tab	Click the Power tab
N'Rnnnn	A number in verilog format, where N is the total number of digits, R is the radix and n is a digit.	4'b0010, 2'hF1
Text in angle brackets < >	A key on the keyboard	Press <Enter>, <F1>
Courier New font:		
Plain Courier New	Sample source code	#define START
	Filenames	autoexec.bat
	File paths	c:\mcc18\h
	Keywords	_asm, _endasm, static
	Command-line options	-Opa+, -Opa-
	Bit values	0, 1
	Constants	0xFF, 'A'
Italic Courier New	A variable argument	<i>file.o</i> , where <i>file</i> can be any valid filename
Square brackets []	Optional arguments	mcc18 [options] <i>file</i> [options]
Curly brackets and pipe character: { }	Choice of mutually exclusive arguments; an OR selection	errorlevel {0 1}
Ellipses...	Replaces repeated text	var_name [, var_name...]
	Represents code supplied by user	void main (void) { ... }

RECOMMENDED READING

This user's guide describes how to use MCP73871 Evaluation Board User's Guide. The following Microchip documents are available and recommended as supplemental reference resources.

MCP73871 Data Sheet, "Stand-Alone Linear Li-Ion / Li-Poly Battery Charge and System Load Sharing Management Controller", DS22090

This data sheet provides detailed information regarding the MCP73871 product family.

THE MICROCHIP WEB SITE

Microchip provides online support via our web site at www.microchip.com. This web site is used as a means to make files and information easily available to customers. Accessible by using your favorite Internet browser, the web site contains the following information:

- **Product Support** – Data sheets and errata, application notes and sample programs, design resources, user's guides and hardware support documents, latest software releases and archived software
- **General Technical Support** – Frequently Asked Questions (FAQs), technical support requests, online discussion groups, Microchip consultant program member listing
- **Business of Microchip** – Product selector and ordering guides, latest Microchip press releases, listing of seminars and events, listings of Microchip sales offices, distributors and factory representatives

CUSTOMER SUPPORT

Users of Microchip products can receive assistance through several channels:

- Distributor or Representative
- Local Sales Office
- Field Application Engineer (FAE)
- Technical Support

Customers should contact their distributor, representative or field application engineer (FAE) for support. Local sales offices are also available to help customers. A listing of sales offices and locations is included in the back of this document.

Technical support is available through the web site at: <http://support.microchip.com>

DOCUMENT REVISION HISTORY

Revision A (August 2008)

- Initial Release of this Document.

MCP73871 Evaluation Board User's Guide

NOTES:

Chapter 1. Product Overview

1.1 INTRODUCTION

Space and complexity are two key concerns in portable electronic design. The highly integrated MCP73871 device has overcome the hurdles by including the required elements to meet the design challenges when developing new Li-Ion / Li-Polymer battery powered products.

The MCP73871 requires minimum external components to power the system load and charge single cell Li-Ion batteries independently. When input power is absent or insufficient, the Li-Ion battery becomes the primary power source or in help mode to support the required system load current. The MCP73871 Evaluation Board is developed to assist product designers in reducing product design cycle and time by utilizing Microchip's favorite stand-alone Li-Ion battery charger and system load sharing management controller.

This chapter provides an overview of the MCP73871 Evaluation Board and covers the following topics:

- "What is the MCP73871 Evaluation Board?"
- "What the MCP73871 Evaluation Board Kit includes"

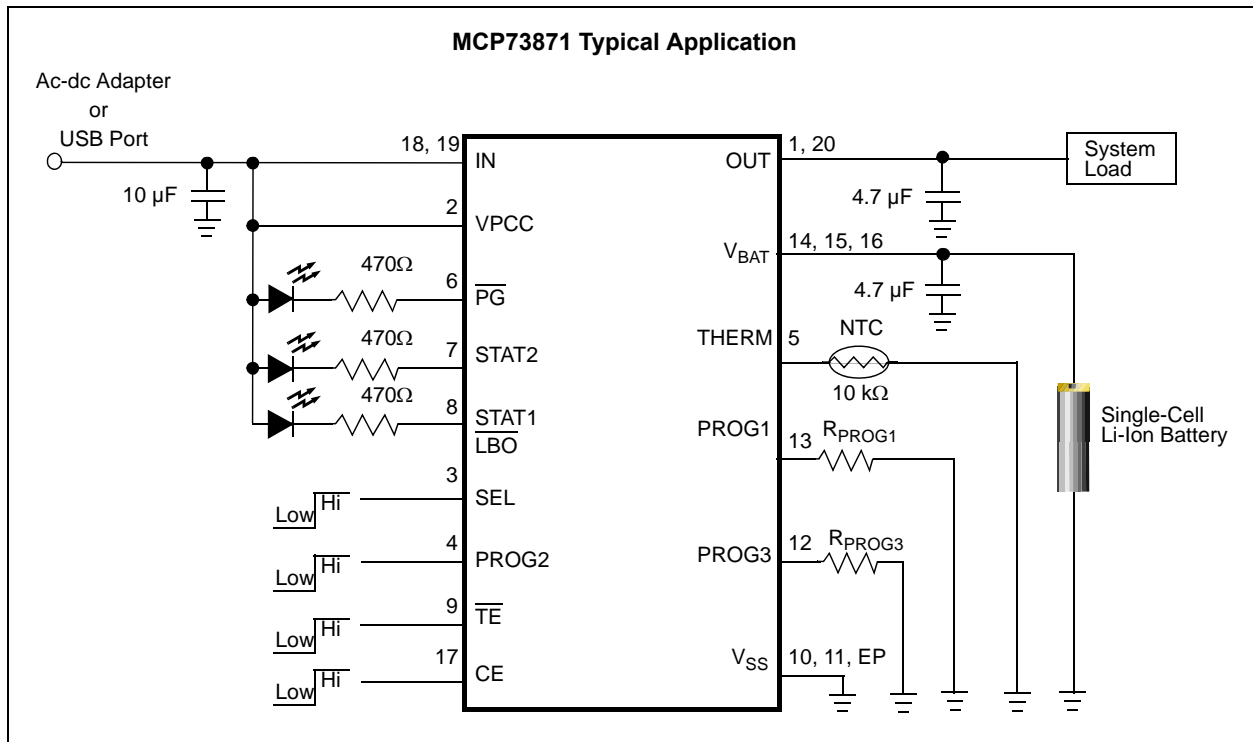

FIGURE 1-1: MCP73871 With System Power Path Management Application.

MCP73871 Evaluation Board User's Guide

1.2 WHAT IS THE MCP73871 EVALUATION BOARD?

The MCP73871 Evaluation Board demonstrates the features of Microchip's MCP73871 "Stand-alone Linear Li-Ion / Li-Poly Battery Charge and System Load Sharing Management Controller".

The MCP73871 Evaluation Board is designed to deliver minimum 1.5A total current to system load and to a single cell Li-Ion battery at 4.2V preset voltage regulation. (4.1V, 4.35V and 4.4V options are also available for MCP73871) The MCP73871 Evaluation Board has two dip switches to control input current limits. First dip switch (SW2) determines input power source between ac-dc adapter and USB port (AC/USB). Second dip switch (SW1) determines 500 mA high power USB port or 100 mA low power USB port (High/Low). The input current limit is governed by USB specification when selecting USB on SW2.

The maximum fast current when AC is selected on SW2 is programmed by resistor (R_{PROG1}) at 1A and termination current is set at 100 mA by (R_{PROG3}).

The MCP73871 Evaluation Board offers three status LED for two charge status outputs and a power good indicator.

Note: Please refer to Table 2-1 for charge status outputs and Figure 2-1 for charge current setups.

The MCP73871 Evaluation Board comes with factory preset low battery indicator (LBO) when input is absent. The preset value is 3.1V and STAT1 LED turns on when battery voltage is below the threshold voltage.

The MCP73871 Evaluation Board is designed to observe the performance and features on the circuits via multiple test points. Circuits can also be implemented into suitable applications without additional work.

Note: For evaluation LBO purpose, connect a DC power supply and set V_{DD} below UVLO. The LBO lights up when V_{BAT} drops below threshold voltage.

1.3 WHAT THE MCP73871 EVALUATION BOARD KIT INCLUDES

This MCP73871 Evaluation Board kit includes:

- MCP73871 Evaluation Board, 102-00183
- Analog and Interface Products Demonstration Boards CD-ROM (DS21912)
 - MCP73871 Evaluation Board User's Guide User's Guide (DS51755)
 - MCP73871 Data Sheet, "Stand-Alone Linear Li-Ion / Li-Poly Battery Charge and System Load Sharing Management Controller" (DS22090)

Chapter 2. Installation and Operation

2.1 INTRODUCTION

The MCP73871 Evaluation Board demonstrates Microchip's stand-alone linear Li-Ion battery charger with system power path and load sharing management control solution. The system load is also supported by the Li-Ion battery when the input power is disconnected. A number of device options allow the MCP73871 to be utilized in a variety of applications. Refer to the MCP73871 Data Sheet (DS22090) and/or contact local Microchip supports for additional device options.

Typical applications for the reference design are Smart Phones, PDA, Portable Media Players, MP3 Players, Digital Cameras, Handheld Medical devices, Bluetooth headsets, Ultra-Mobile PC and Portable Communicators.

2.2 FEATURES

The MCP73871 Evaluation Board has the following features:

- Integrated System Load Sharing
- Input Current Limit Control with dip switches between ac-dc adapter (Typical 1650 mA), USB-High (Maximum 500 mA) and USB-Low (Maximum 100 mA)
- Three LED indicates charge status, low battery and power good signal
- Preset Li-Ion battery charge voltage: 4.2V \pm 0.5%
- Temperature monitoring is disabled by default, but can be enabled to use with NTC thermister
- Factory preset 0.1C preconditioning current of deeply depleted cells
- Factory preset 6 hour Safety Timer with Timer Enable feature
- Constant Current / Constant Voltage (CC/CV) charge algorithm
- Resistor programmed maximum charge current: 1A
- Resistor programmed termination set point: 100 mA
- Automatic Charge Termination
- Automatic Recharge
- Internal Thermal Regulation
- Exposed Pad with extra via underneath for better heat dissipations

MCP73871 Evaluation Board User's Guide

2.3 GETTING STARTED

The MCP73871 Evaluation Board is fully assembled and tested for charging a single-cell Li-Ion or Li-Polymer battery with or without system load.

2.3.1 Power Input and Output Connection

2.3.1.1 POWERING THE MCP73871 EVALUATION BOARD

1. Connect the positive battery terminal to V_{BAT+} (TP4) and negative battery terminal to V_{SS} (TP1 or TP5).
2. Connect the 5V - 6V DC power supply Negative Terminal to V_{SS} (TP1 or TP5).
3. Connect the 5V - 6V DC power supply Positive Terminal to V_{DD} (TP2).
4. Connected positive of load to OUT (TP3) on the board and negative of load to either V_{SS} (TP1 or TP5). The system load can be a power resistor or E-Load.
5. The maximum current that system load requires should not violate the specification of Li-Ion battery manufacturer (Typical at 1C or less) or 1A for safety and performance concerns.
6. It should initiate the battery charging cycle when drive CE (TP6) high. Drive CE (TP6) low disables the Li-Ion battery charger function.
7. Position the DIP Switch #2 (SW2) to "AC" allows maximum input current of 1.8A to support both system load and Li-Ion battery charger at 1000 mA fast charge current rate.
8. Position the DIP Switch #2 (SW2) to "USB" limits the input current to meet USB specifications.
9. When DIP Switch #2 (SW2) is positioned at USB; position the DIP Switch #1 (SW1) to "High" limits total input current to 500 mA and "Low" for maximum input current at 100 mA.

Note: Fast Charge Current and Termination Current can be easily programmed with various resistors that based on the Figure 2-1.
The Li-Ion battery pack can be replaced with test circuit or electronic load that can sink current with DC power supply. Please refer to Figure 2-2.

10. Remove DC power supply, the load should be supported by the Li-Ion battery now.

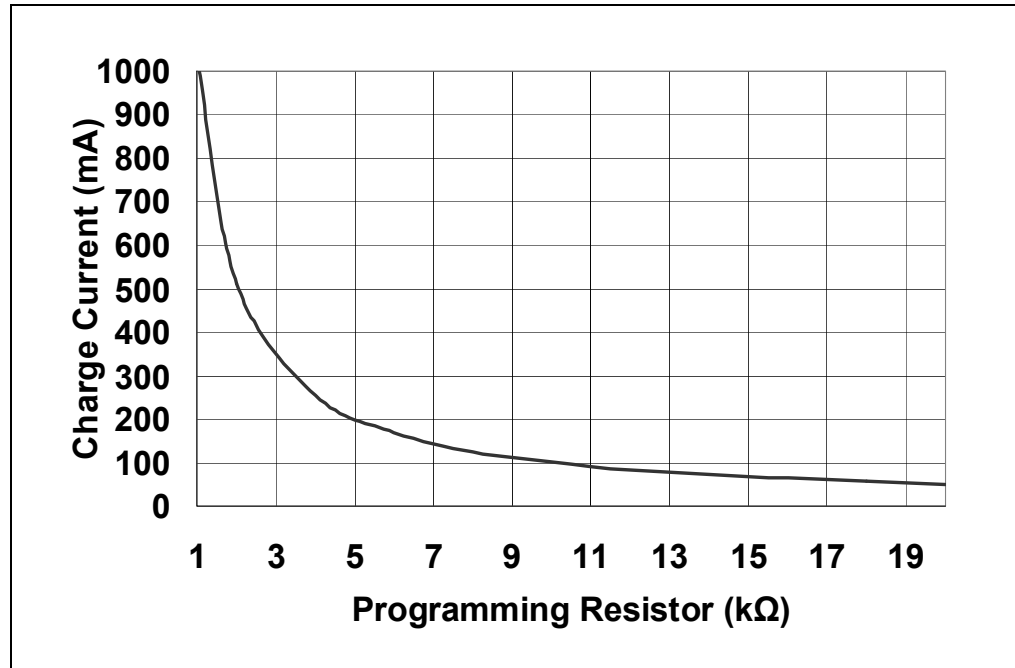

FIGURE 2-1: MCP73833 Charge Current (I_{OUT}) vs. Programming Resistor (R_{PROG}).

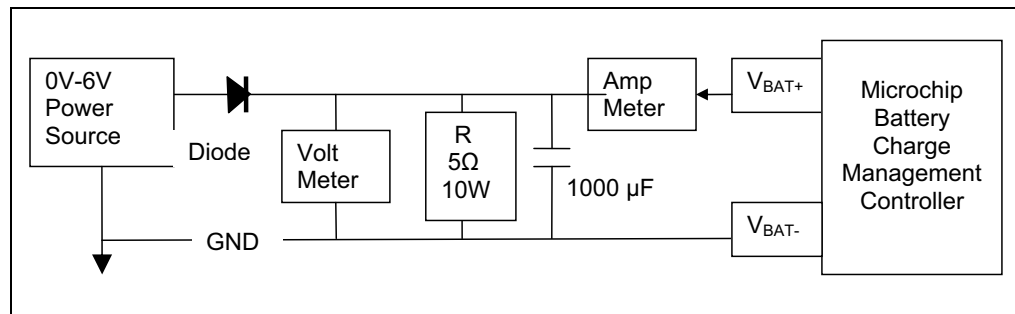

FIGURE 2-2: Simulated Battery Load.

MCP73871 Evaluation Board User's Guide

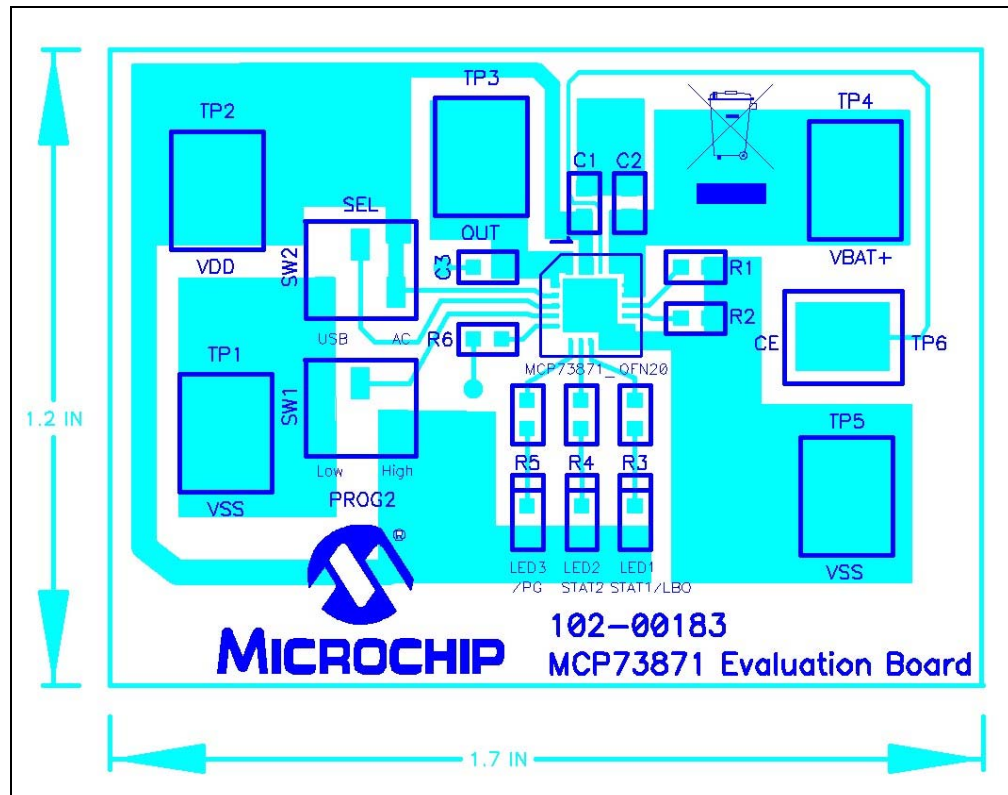

FIGURE 2-3: MCP73871 Board Layout and Dimensions.

TABLE 2-1: MCP73871 CHARGE STATUS OUTPUTS

CHARGE CYCLE STATE	STAT1 (Green)	STAT2 (Red)	$\overline{\text{PG}}$ (Blue)
Shutdown	OFF	OFF	OFF
Standby	OFF	OFF	ON
Charge in Progress	ON	OFF	ON
Charge Complete (EOC)	OFF	ON	ON
Temperature Fault	ON	ON	ON
Timer Fault	ON	ON	ON
Low Battery Indicator (LBO)	ON	OFF	OFF
No Battery Present	OFF	OFF	ON
No Input Power	OFF	OFF	OFF



MCP73871 EVALUATION BOARD USER'S GUIDE

Appendix A. Schematic and Layouts

A.1 INTRODUCTION

This appendix contains the following schematics and layouts for the MCP73871 Evaluation Board:

- Board – Schematic Sheet
- Board – Top Layer
- Board – Top Metal Layer
- Board – Bottom Layer

MCP73871 Evaluation Board User's Guide

A.2 BOARD – SCHEMATIC

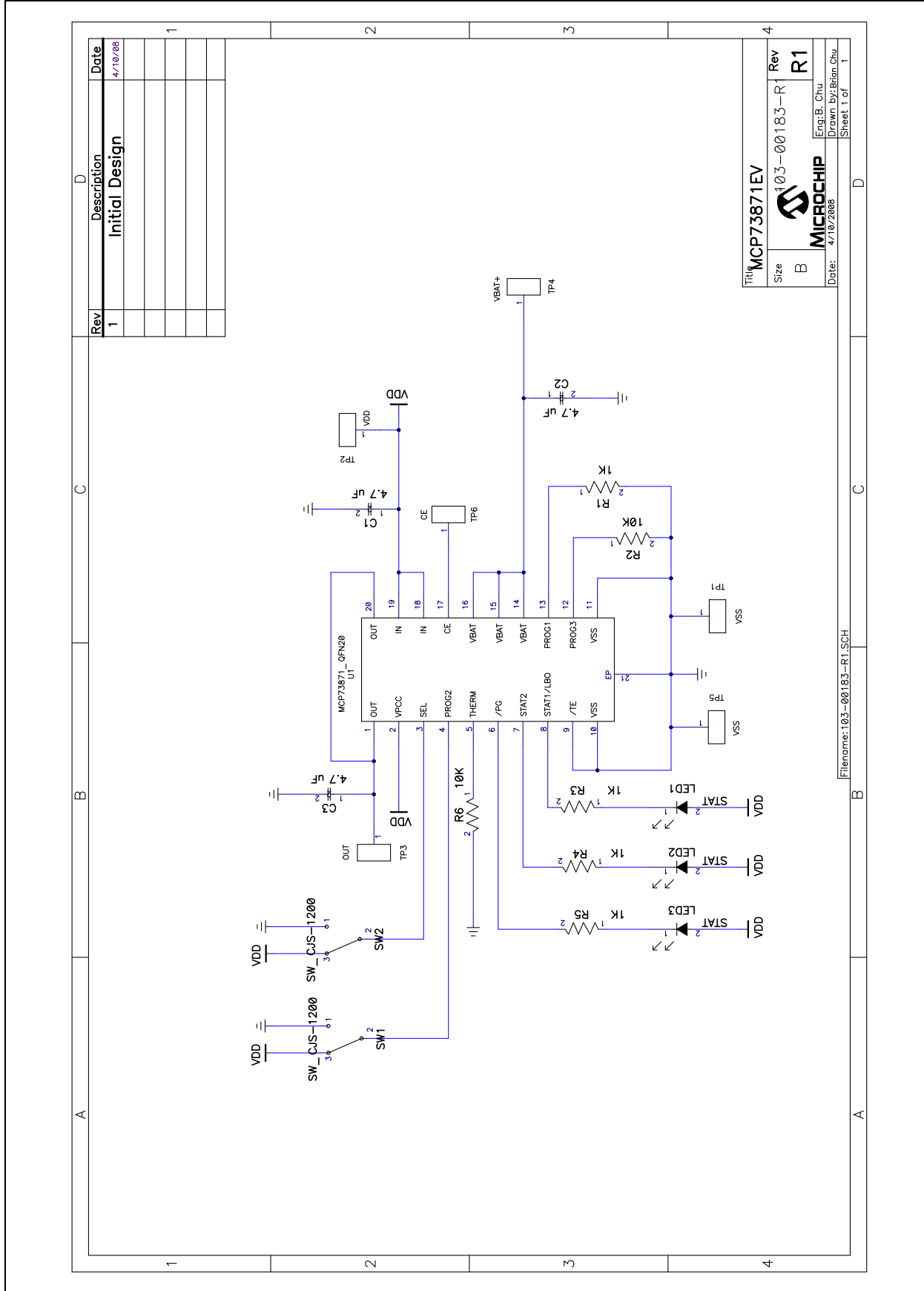

A.3 BOARD – TOP LAYER

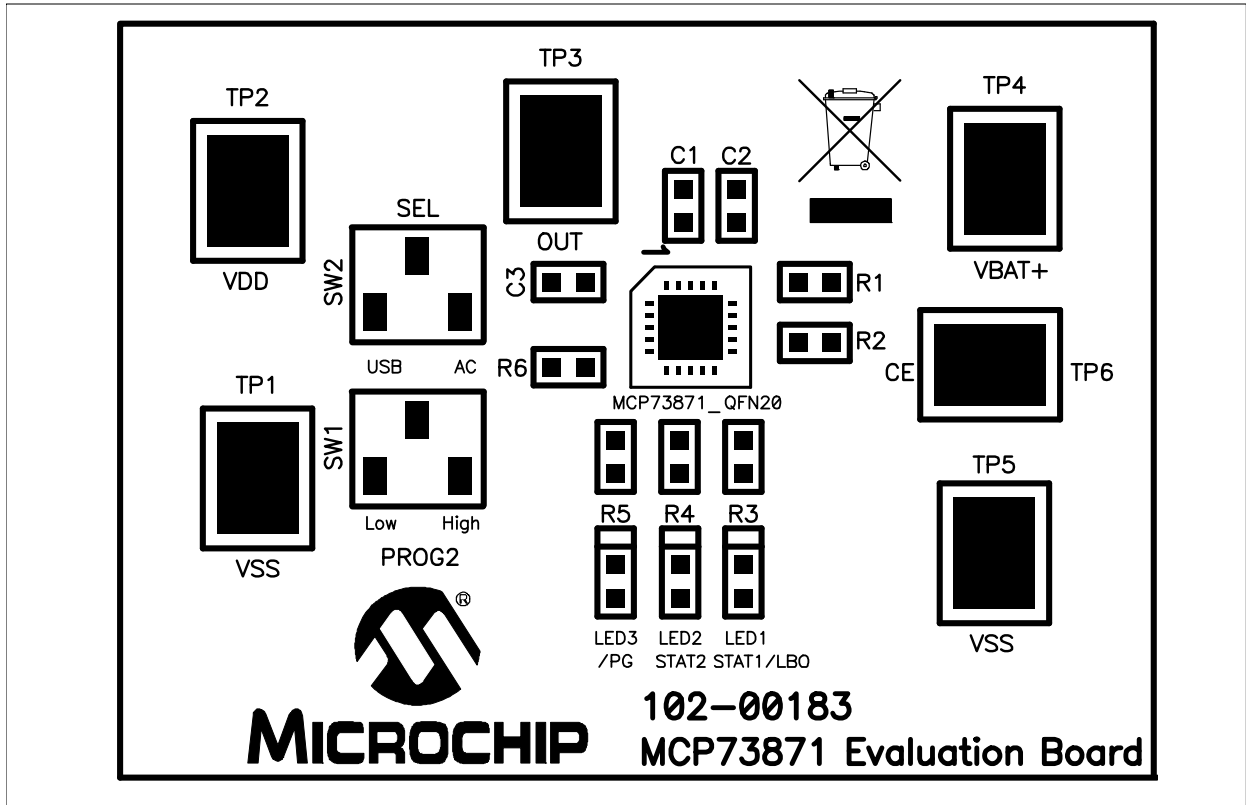

A.4 BOARD – TOP METAL LAYER

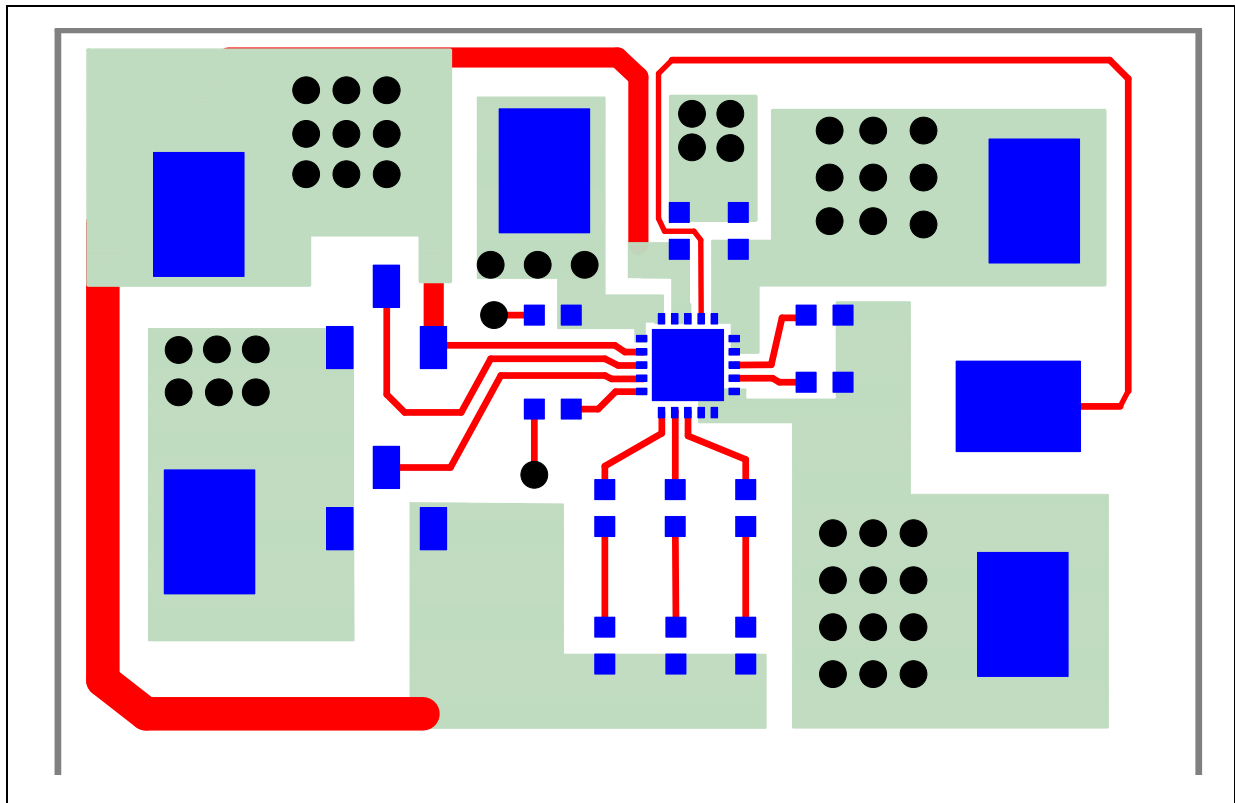

MCP73871 Evaluation Board User's Guide

A.5 BOARD – BOTTOM LAYER

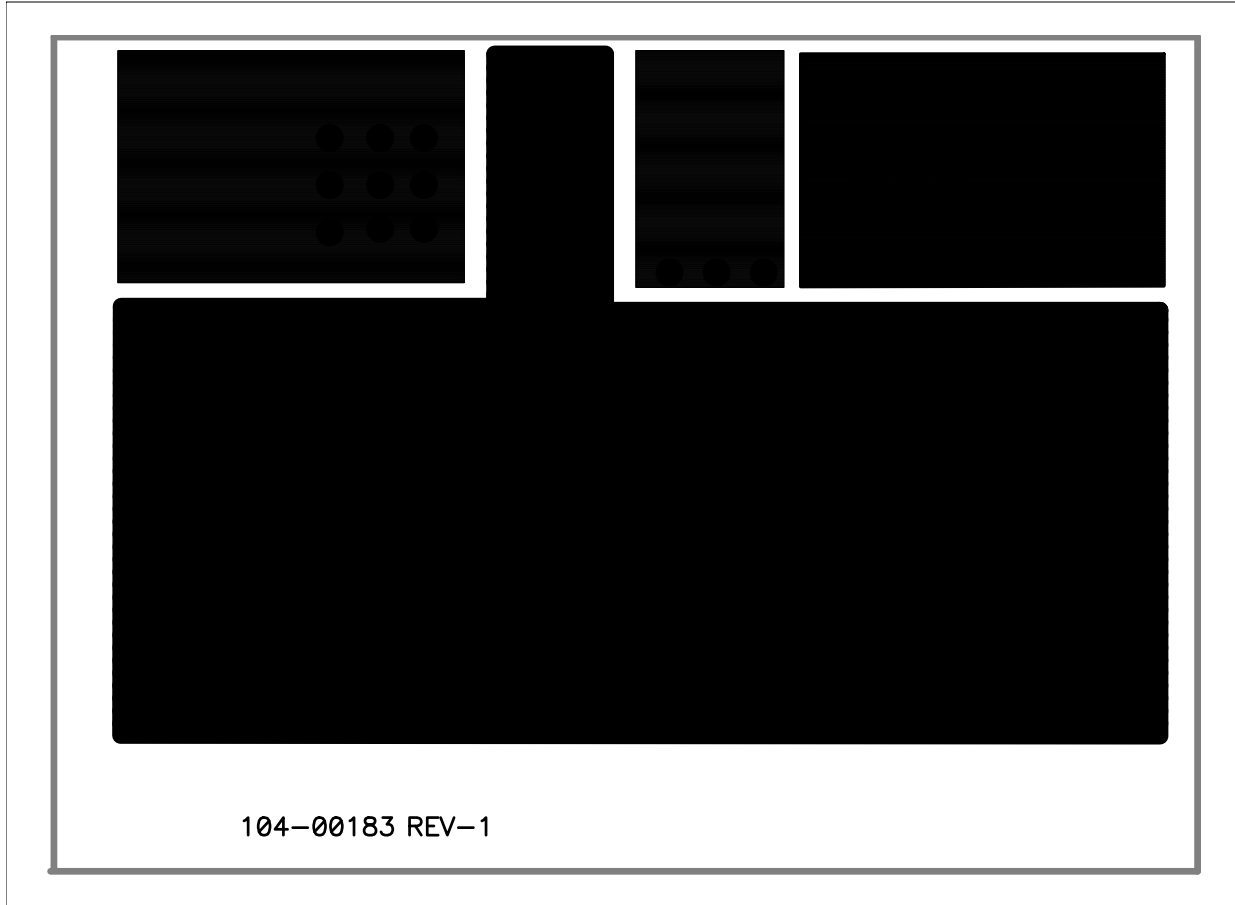

Appendix B. Bill Of Materials (BOM)

TABLE B-1: BILL OF MATERIALS (BOM)

Qty	Reference	Description	Manufacturer	Part Number
4	Bump	BUMPON HEMISPHERE 0.44 X 0.20 WHITE	3M	SJ5003-9-ND
3	C1, C2, C3	CAP CERAMIC 4.7 μ F 10 X5R 0603	Taiyo Yuden [®]	LMK107BJ475KA-T
1	LED1	True Green Water Clear 0603 SMD LED	Para Light USA	L-C191LGCT-U1
1	LED2	Super Red Water Clear 0603 SMD LED	Para Light USA	L-C191KRCT-U1
1	LED3	Blue Water Clear 0603 SMD LED	Para Light USA	L-C191LBCT-U1
1	PCB	Printed Circuit Board	Microchip Technology Inc.	104-00183-R1
4	R1, R3, R4, R5	RES 1K OHM 1/10W 1% 0603 SMD	Panasonic [®] - ECG	ERJ-3EKF1001V
2	R2, R6	RES 10K OHM 1/10W 1% 0603 SMD	Panasonic - ECG	ERJ-3EKF1002V
2	SW1, SW2	SWITCH SLIDE SPDT SMD J-LEAD	Copal Electronics Inc	CJS-1200TA
6	TP1, TP2, TP3, TP4, TP5, TP6	PC Test Point Compact SMT	Keystone Electronics [®]	5016
1	U1	Stand-Alone System Load Sharing and Li-Ion / Li-Polymer Battery Charge Management Controller; 4.2V Charge Voltage Regulation Option	Microchip Technology, Inc	MCP73871-2CCI/ML

Note: The components listed in this Bill of Materials are representative of the PCB assembly. The released BOM used in manufacturing uses all RoHS-compliant components.



WORLDWIDE SALES AND SERVICE

AMERICAS

Corporate Office
2355 West Chandler Blvd.
Chandler, AZ 85224-6199
Tel: 480-792-7200
Fax: 480-792-7277
Technical Support:
<http://support.microchip.com>
Web Address:
www.microchip.com

Atlanta
Duluth, GA
Tel: 678-957-9614
Fax: 678-957-1455

Boston
Westborough, MA
Tel: 774-760-0087
Fax: 774-760-0088

Chicago
Itasca, IL
Tel: 630-285-0071
Fax: 630-285-0075

Dallas
Addison, TX
Tel: 972-818-7423
Fax: 972-818-2924

Detroit
Farmington Hills, MI
Tel: 248-538-2250
Fax: 248-538-2260

Kokomo
Kokomo, IN
Tel: 765-864-8360
Fax: 765-864-8387

Los Angeles
Mission Viejo, CA
Tel: 949-462-9523
Fax: 949-462-9608

Santa Clara
Santa Clara, CA
Tel: 408-961-6444
Fax: 408-961-6445

Toronto
Mississauga, Ontario,
Canada
Tel: 905-673-0699
Fax: 905-673-6509

ASIA/PACIFIC

Asia Pacific Office
Suites 3707-14, 37th Floor
Tower 6, The Gateway
Harbour City, Kowloon
Hong Kong
Tel: 852-2401-1200
Fax: 852-2401-3431

Australia - Sydney
Tel: 61-2-9868-6733
Fax: 61-2-9868-6755

China - Beijing
Tel: 86-10-8528-2100
Fax: 86-10-8528-2104

China - Chengdu
Tel: 86-28-8665-5511
Fax: 86-28-8665-7889

China - Hong Kong SAR
Tel: 852-2401-1200
Fax: 852-2401-3431

China - Nanjing
Tel: 86-25-8473-2460
Fax: 86-25-8473-2470

China - Qingdao
Tel: 86-532-8502-7355
Fax: 86-532-8502-7205

China - Shanghai
Tel: 86-21-5407-5533
Fax: 86-21-5407-5066

China - Shenyang
Tel: 86-24-2334-2829
Fax: 86-24-2334-2393

China - Shenzhen
Tel: 86-755-8203-2660
Fax: 86-755-8203-1760

China - Wuhan
Tel: 86-27-5980-5300
Fax: 86-27-5980-5118

China - Xiamen
Tel: 86-592-2388138
Fax: 86-592-2388130

China - Xian
Tel: 86-29-8833-7252
Fax: 86-29-8833-7256

China - Zhuhai
Tel: 86-756-3210040
Fax: 86-756-3210049

ASIA/PACIFIC

India - Bangalore
Tel: 91-80-4182-8400
Fax: 91-80-4182-8422

India - New Delhi
Tel: 91-11-4160-8631
Fax: 91-11-4160-8632

India - Pune
Tel: 91-20-2566-1512
Fax: 91-20-2566-1513

Japan - Yokohama
Tel: 81-45-471- 6166
Fax: 81-45-471-6122

Korea - Daegu
Tel: 82-53-744-4301
Fax: 82-53-744-4302

Korea - Seoul
Tel: 82-2-554-7200
Fax: 82-2-558-5932 or
82-2-558-5934

Malaysia - Kuala Lumpur
Tel: 60-3-6201-9857
Fax: 60-3-6201-9859

Malaysia - Penang
Tel: 60-4-227-8870
Fax: 60-4-227-4068

Philippines - Manila
Tel: 63-2-634-9065
Fax: 63-2-634-9069

Singapore
Tel: 65-6334-8870
Fax: 65-6334-8850

Taiwan - Hsin Chu
Tel: 886-3-572-9526
Fax: 886-3-572-6459

Taiwan - Kaohsiung
Tel: 886-7-536-4818
Fax: 886-7-536-4803

Taiwan - Taipei
Tel: 886-2-2500-6610
Fax: 886-2-2508-0102

Thailand - Bangkok
Tel: 66-2-694-1351
Fax: 66-2-694-1350

EUROPE

Austria - Wels
Tel: 43-7242-2244-39
Fax: 43-7242-2244-393

Denmark - Copenhagen
Tel: 45-4450-2828
Fax: 45-4485-2829

France - Paris
Tel: 33-1-69-53-63-20
Fax: 33-1-69-30-90-79

Germany - Munich
Tel: 49-89-627-144-0
Fax: 49-89-627-144-44

Italy - Milan
Tel: 39-0331-742611
Fax: 39-0331-466781

Netherlands - Drunen
Tel: 31-416-690399
Fax: 31-416-690340

Spain - Madrid
Tel: 34-91-708-08-90
Fax: 34-91-708-08-91

UK - Wokingham
Tel: 44-118-921-5869
Fax: 44-118-921-5820

X-ON Electronics

Largest Supplier of Electrical and Electronic Components

Click to view similar products for [Power Management IC Development Tools](#) category:

Click to view products by [Microchip](#) manufacturer:

Other Similar products are found below :

[EVB-EP5348UI](#) [MIC23451-AAAYFL EV](#) [MIC5281YMME EV](#) [124352-HMC860LP3E](#) [DA9063-EVAL](#) [ADP122-3.3-EVALZ](#) [ADP130-0.8-EVALZ](#) [ADP130-1.8-EVALZ](#) [ADP1740-1.5-EVALZ](#) [ADP1870-0.3-EVALZ](#) [ADP1874-0.3-EVALZ](#) [ADP199CB-EVALZ](#) [ADP2102-1.25-EVALZ](#) [ADP2102-1.875EVALZ](#) [ADP2102-1.8-EVALZ](#) [ADP2102-2-EVALZ](#) [ADP2102-3-EVALZ](#) [ADP2102-4-EVALZ](#) [AS3606-DB](#) [BQ25010EVM](#) [BQ3055EVM](#) [ISLUSBI2CKIT1Z](#) [LP38512TS-1.8EV](#) [EVAL-ADM1186-1MBZ](#) [EVAL-ADM1186-2MBZ](#) [ADP122UJZ-REDYKIT](#) [ADP166Z-REDYKIT](#) [ADP170-1.8-EVALZ](#) [ADP171-EVALZ](#) [ADP1853-EVALZ](#) [ADP1873-0.3-EVALZ](#) [ADP198CP-EVALZ](#) [ADP2102-1.0-EVALZ](#) [ADP2102-1-EVALZ](#) [ADP2107-1.8-EVALZ](#) [ADP5020CP-EVALZ](#) [CC-ACC-DBMX-51](#) [ATPL230A-EK](#) [MIC23250-S4YMT EV](#) [MIC26603YJL EV](#) [MIC33050-SYHL EV](#) [TPS60100EVM-131](#) [TPS65010EVM-230](#) [TPS71933-28EVM-213](#) [TPS72728YFFEVM-407](#) [TPS79318YEQEVM](#) [UCC28810EVM-002](#) [XILINXPWR-083](#) [LMR22007YMINI-EVM](#) [LP38501ATJ-EV](#)