MGC3030/3130 3D Tracking and Gesture Controller Data Sheet

Introduction

Microchip's MGC3X30 are 3D gesture recognition and motion tracking controller chips based on Microchip's patented GestIC[®] technology. They enable user-command input with natural hand and finger movements. Applying the principles of electrical near-field sensing, the MGC3X30 contain all the building blocks to develop robust 3D gesture input sensing systems. Implemented as a low-power mixed-signal configurable controller, they provide a large set of smart functional features with integrated signal driver, a frequency adaptive input path for automatic noise suppression and a digital signal processing unit. Microchip's on-chip Colibri Suite obsoletes processing needs at the host, reduces system power consumption resulting in low software development efforts for short time-to-market success. The MGC3XXX family represents a unique solution that provides gesture information of the human hand in real time. Dedicated chip family members add position data, touch or multi touch information to the free space gesture sensing. The MGC3XXX allow the realization of a new generation of user interfaces across various industry markets.

Applications

- Audio Products
- Notebooks/Keyboards/PC Peripherals
- Home Automation
- White Goods
- Switches/Industrial Switches
- Medical Products
- Game Controllers
- Audio Control

Power Features

- Variety of Several Power Operation modes include:
 - Processing mode: 20 mA @ 3.3V, typical
 - Programmable Self Wake-up: 110 μ A @ 3.3V
 - Deep Sleep: 9 μ A @ 3.3V, typical

Key Features

- Recognition of 3D Hand Gestures and x, y, z Positional Data (MGC3130)
- Proximity and Touch Sensing
- Built-in Colibri Gesture Suite (running on chip)
- Advanced 3D Signal Processing Unit
- Detection Range: 0 to 10 cm
- Receiver Sensitivity: <1 fF
- Position Rate: 200 positions/sec
- Spatial Resolution: up to 150 dpi
- Carrier Frequency: 44 kHz to 115 kHz
- Channels Supported:
 - Five receive (Rx) channels
 - One transmit (Tx) channel
- On-chip Auto Calibration
- Low Noise Radiation due to Low Transmit Voltage and Slew Rate Control
- Noise Susceptibility Reduction:
 - On-chip analog filtering
 - On-chip digital filtering
 - Automatic frequency hopping
- Enables the use of Low-Cost Electrode Material including:
 - Printed circuit board
 - Conductive paint
 - Conductive foil
 - Laser Direct Structuring (LDS)
 - Touch panel ITO structures
- Field Upgrade Capability
- Operating Voltage: 3.3V (+/-5%) (single supply)
- Temperature Range: -20°C to +85°C

Peripheral Features

- 1x I²C[™] Interface for Configuration and Sensor output streaming
- Five Gesture Port pins for individual mapping of gesture to EIOs

Note: This data sheet applies to parts MGC3030 and MGC3130. Throughout this document the term MGC3X30 will be representative for these two parts.
--

MGC3030/3130

TABLE 1: MGC3X30 AVAILABLE PACKAGES

Part number	Available Package	Pins	Contact/Lead Pitch	Dimensions
MGC3030	SSOP	28	0.65	7.80x10.50
MGC3130	QFN	28	0.5	5x5

Note: All dimensions are in millimeters (mm) unless specified.

TABLE 2: MGC3X30 FEATURE OVERVIEW

	Gesture Recognition	Position Tracking	Raw Data Streaming	Multi Touch Finger Tracking	Wake-up on Approach	Deep Sleep	Gesture Port Pins	Rx Receive Electrodes	I ² C™ Ports
MGC3030	Yes	No	Yes	No	Yes	Yes	5	5	1
MGC3130	Yes	Yes	Yes	No	Yes	Yes	5	5	1

Pin Diagrams

FIGURE 1: 28-PIN DIAGRAM (MGC3130)

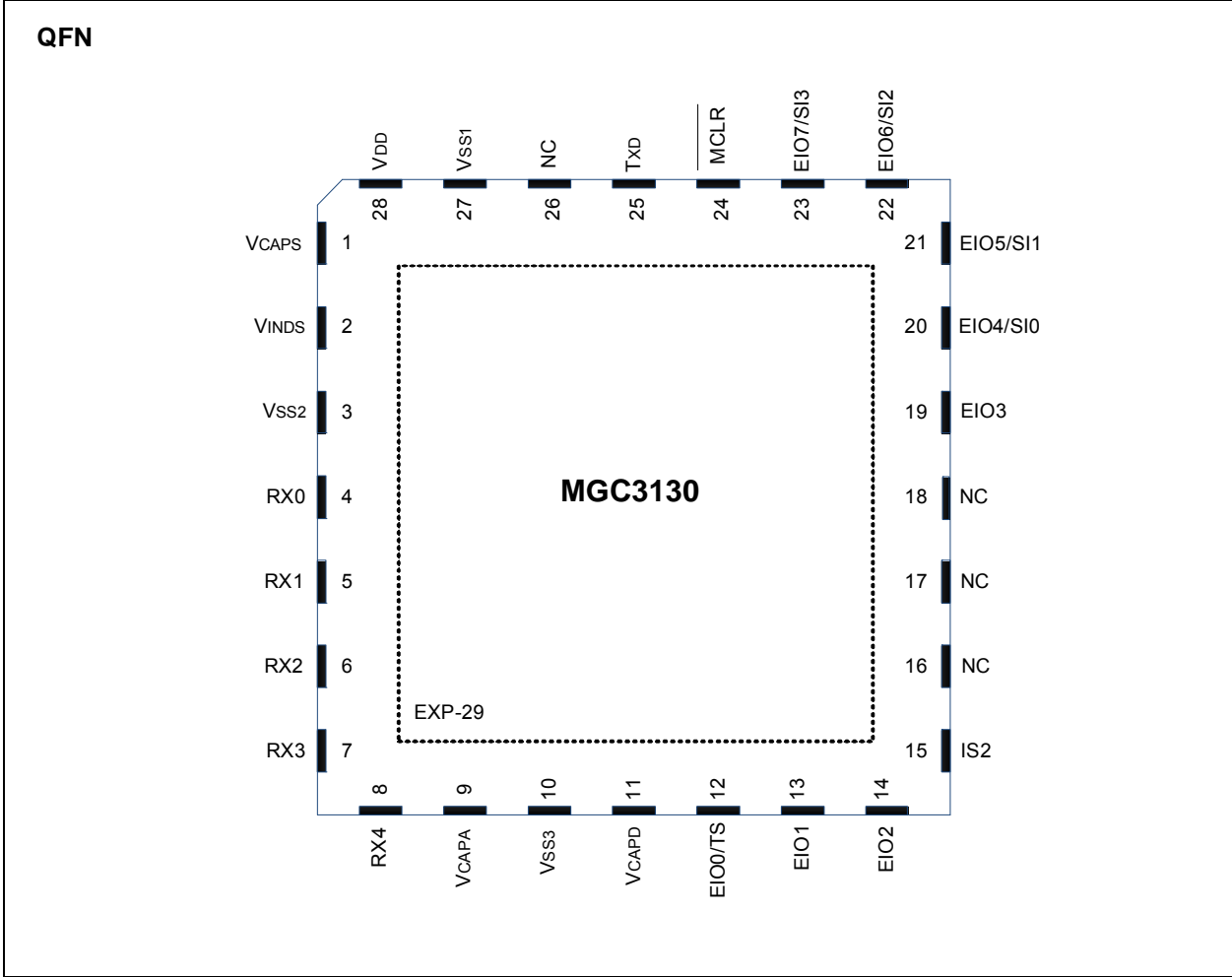

MGC3030/3130

FIGURE 2: 28-PIN DIAGRAM (MGC3030)

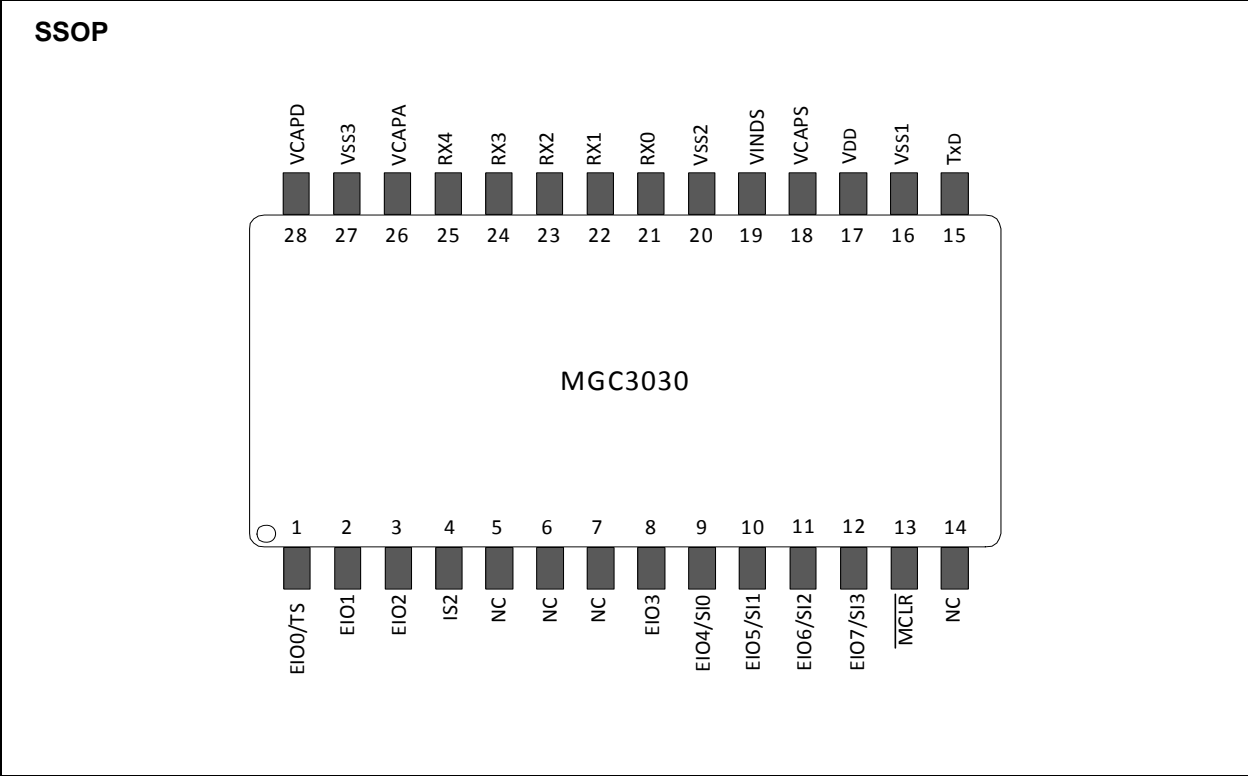

TABLE 3: PIN SUMMARY

Pin Name	Pin Number		Pin Type	Buffer Type	Description
	28-QFN	28-SSOP			
VCAPS	1	18	P	—	Reserved: Connect to VDD.
VINDS	2	19	P	—	Reserved: Do not connect.
VSS2	3	20	P	—	Ground.
RX0	4	21	I	Analog	Analog input channels: Receive electrode connection.
RX1	5	22	I	Analog	
RX2	6	23	I	Analog	
RX3	7	24	I	Analog	
RX4	8	25	I	Analog	
VCAPA	9	26	P	—	External filter capacitor (4.7 μ F) connection for internal analog.
VSS3	10	27	P	—	Common ground reference for analog and digital domain.
VCAPD	11	28	P	—	External filter capacitor (4.7 μ F) connection for internal digital.
EIO0/TS	12	1	I/O	ST	Extended IO0 (EIO0)/Transfer Status (TS). TS line requires pull-up.
EIO1	13	2	I/O	ST	Extended IO1 (EIO1)/Interface Selection Pin 1 (IS1).
EIO2	14	3	I/O	ST	Extended IO2 (EIO2)/IRQ0.
IS2	15	4	I	ST	Interface Selection Pin 2 (IS2).
NC	16	5	—	—	Reserved: do not connect.
NC	17	6	—	—	Reserved: do not connect.
NC	18	7	—	—	Reserved: do not connect.
EIO3	19	8	I/O	ST	Extended IO3 (EIO3)/IRQ1.
EIO4/SI0	20	9	I/O	ST	Extended IO4 (EIO4)/Serial Interface 0 (SI0): I ² C™_SDA0. line requires an external 1.8 k Ω pull-up.
EIO5/SI1	21	10	I/O	ST	Extended IO5 (EIO5)/Serial Interface 1 (SI1): I ² C™_SCL0. line requires an external 1.8 k Ω pull-up.
EIO6/SI2	22	11	I/O	ST	Extended IO6 (EIO6).
EIO7/SI3	23	12	I/O	ST	Extended IO7 (EIO7).
MCLR	24	13	I/P	ST	Master Clear (Reset) input. This pin is an active-low Reset external 10 k Ω pull-up.
TXD	25	15	O	Analog	Transmit electrode connection.

Legend: P = Power; ST = Schmitt Trigger input with CMOS levels; O = Output; I = Input; — = N/A

TABLE 3: PIN SUMMARY

Pin Name	Pin Number		Pin Type	Buffer Type	Description
	28-QFN	28-SSOP			
NC	26	14	—	—	Reserved: do not connect.
VSS1	27	16	P	—	Common ground reference for analog and digital domains.
VDD	28	17	P	—	Positive supply for peripheral logic and I/O pins. It requires tor (100 nF).
EXP	29	—	P	—	Exposed pad. It should be connected to Ground.

Legend: P = Power; ST = Schmitt Trigger input with CMOS levels; O = Output; I = Input; — = N/A

Table of Contents

1.0	Theory of Operation: Electrical Near-Field (E-Field Sensing).....	8
2.0	Feature Description	10
3.0	System Architecture.....	14
4.0	Functional Description	17
5.0	Interface Description	26
6.0	Application Architecture	34
7.0	Development Support	37
8.0	Electrical Specifications	39
9.0	Packaging Information	40
	The Microchip Website	47
	Customer Change Notification Service	47
	Customer Support.....	47
	Product Identification System	48

TO OUR VALUED CUSTOMERS

It is our intention to provide our valued customers with the best documentation possible to ensure successful use of your Microchip products. To this end, we will continue to improve our publications to better suit your needs. Our publications will be refined and enhanced as new volumes and updates are introduced.

If you have any questions or comments regarding this publication, please contact the Marketing Communications Department via E-mail at docerrors@microchip.com. We welcome your feedback.

Most Current Data Sheet

To obtain the most up-to-date version of this data sheet, please register at our Worldwide Website at:

<http://www.microchip.com>

You can determine the version of a data sheet by examining its literature number found on the bottom outside corner of any page. The last character of the literature number is the version number, (e.g., DS30000000A is version A of document DS30000000).

Errata

An errata sheet, describing minor operational differences from the data sheet and recommended workarounds, may exist for current devices. As device/documentation issues become known to us, we will publish an errata sheet. The errata will specify the revision of silicon and revision of document to which it applies.

To determine if an errata sheet exists for a particular device, please check with one of the following:

- Microchip's Worldwide Website; <http://www.microchip.com>
- Your local Microchip sales office (see last page)

When contacting a sales office, please specify which device, revision of silicon and data sheet (include literature number) you are using.

Customer Notification System

Register on our website at www.microchip.com to receive the most current information on all of our products.

1.0 THEORY OF OPERATION: ELECTRICAL NEAR-FIELD (E-FIELD) SENSING

Microchip's GestIC is a 3D sensor technology which utilizes an electric field (E-field) for advanced proximity sensing. It allows realization of new user interface applications by detection, tracking and classification of a user's hand gestures in free space.

E-fields are generated by electrical charges and propagate three-dimensionally around the surface, carrying the electrical charge.

Applying direct voltages (DC) to an electrode results in a constant electric field. Applying alternating voltages (AC) makes the charges vary over time and thus, the field. When the charge varies sinusoidal with frequency f , the resulting electromagnetic wave is characterized by wavelength $\lambda = c/f$, where c is the wave propagation velocity — in vacuum, the speed of light. In cases where the wavelength is much larger than the electrode geometry, the magnetic component is practically zero and no wave propagation takes place. The result is quasi-static electrical near field that can be used for sensing conductive objects such as the human body.

Microchip's GestIC technology uses transmit (Tx) frequencies in the range of 100 kHz which reflects a wavelength of about three kilometers. With electrode geometries of typically less than fourteen by fourteen centimeters, this wavelength is much larger in comparison. GestIC systems work w/o wave propagation.

In case a person's hand or finger intrudes the electrical field, the field becomes distorted. The field lines are drawn to the hand due to the conductivity of the human body itself and shunted to ground. The three-dimensional electric field decreases locally. Microchip's GestIC technology uses a minimum number of four receiver (Rx) electrodes to detect the E-field variations at different positions to measure the origin of the electric field distortion from the varying signals received. The information is used to calculate the position, track movements (MGC3130) and to classify movement patterns (gestures, MGC3X30).

Figure 1-1 and Figure 1-2 show the influence of an earth-grounded body to the electric field. The proximity of the body causes a compression of the equipotential lines and shifts the Rx electrode signal levels to a lower potential which is measured.

FIGURE 1-1: EQUIPOTENTIAL LINES OF AN UNDISTORTED E-FIELD

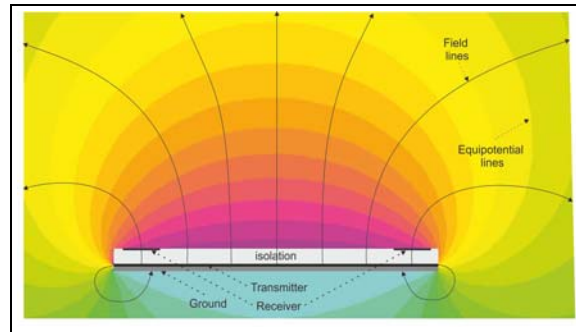
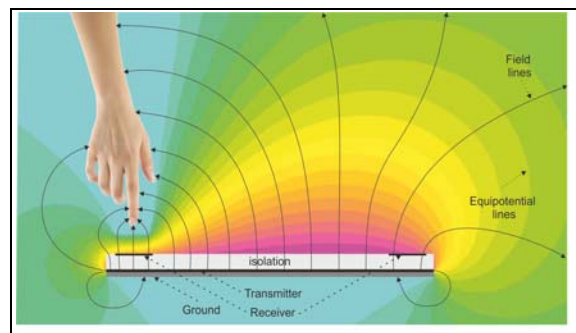

FIGURE 1-2: EQUIPOTENTIAL LINES OF A DISTORTED E-FIELD



1.1 GestIC Technology Benefits

- GestIC E-field sensors are not impacted by ambient influences such as light or sound, which have a negative impact to the majority of other 3D technologies.
- GestIC technology allows gesture/position tracking processing on chip – no host processing needed. Algorithms are included in the Colibri gesture suite which runs on chip and is provided by Microchip.
- The GestIC technology has a high immunity to noise, provides high update rates and resolution, low latency and is also not affected by clothing, surface texture or reflectivity.
- A carrier frequency in the range of 44-115 kHz is being used with the benefit of being outside the regulated radio frequency range. In the same manner, GestIC is not affected by radio interference.
- Usage of thin low-cost materials as electrodes allow low system cost at slim industrial designs.
- The further use of existing capacitive sensor structures such as a touch panel's ITO coating allow additional cost savings and ease the integration of the technology.
- Electrodes are invisible to the users' eye since they are implemented underneath the housing surface or integrated into a touch panel's ITO structure.
- GestIC works centrally over the full sensing space. Thus, it provides full surface coverage without any detection blind spots.
- Only one GestIC transmitter electrode is used for E-field generations. The benefit is an overall low power consumption and low radiated EMC noise.
- Since GestIC is basically processing raw electrode signals and computes them in real time into pre-processed gestures and x, y, z positional data, it provides a highly flexible user interface technology for any kind of electronic devices.

2.0 FEATURE DESCRIPTION

2.1 Gesture Definition

A hand gesture is the movement of the hand to express an idea or meaning. The GestIC[®] technology accurately allows sensing of a user's free space hand motion for contact free position tracking, as well as 3D gesture recognition based on classified movement patterns.

2.2 GestIC Library

MGC3X30 is being provided with a GestIC Library loader which is stored on the chip's Flash memory. Using this loader, a GestIC Library can be flashed on the MGC3X30 via I²C™ with (e.g., Aurea GUI) (see [Section 7.1 "Aurea Software Package"](#)) or an embedded host controller. The GestIC Library includes:

- Colibri Suite: Digital Signal Processing (DSP) algorithms and feature implementations.
- System Control: MGC3X30 hardware control features such as Analog Front End (AFE) access, interface control and parameters storage.
- Library Loader: GestIC Library update through the application host's interface.

2.2.1 COLIBRI SUITE

The Colibri Suite combines data acquisition, digital signal processing and interpretation.

The Colibri Suite functional features are illustrated in [Figure 2-1](#) and described in the following sections.

FIGURE 2-1: COLIBRI SUITE CORE ELEMENTS

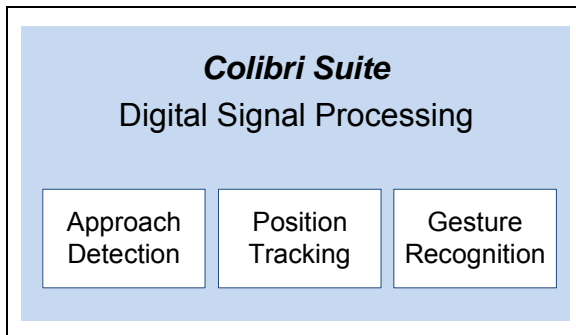

2.2.1.1 Position Tracking (MGC3130)

The Colibri Suite's Position Tracking feature provides three-dimensional hand position over time and area. The absolute position data is provided according to the defined origin of the Cartesian coordinate system (x, y, z). Position Tracking data is continuously acquired in parallel to Gesture Recognition. With a position rate of up to 200 positions/sec., a maximum spatial resolution of 150 dpi is achieved.

2.2.1.2 Gesture Recognition (MGC3X30)

The Colibri Suite's gesture recognition model detects and classifies hand movement patterns performed inside the sensing area.

Using advanced stochastic classification based on Hidden Markov Model (HMM), industry best gesture recognition rate is being achieved.

The Colibri Suite includes a set of predefined hand gestures which contains flick, circular and symbol gestures as the ones outlined below:

- **Flick gestures**

FIGURE 2-2: FLICK GESTURES

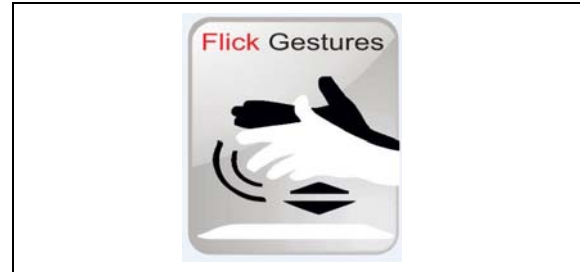

A flick gesture is a unidirectional gesture in a quick flicking motion. An example may be a hand movement from West to East within the sensing area, from South to North, etc.

- **Circular gestures**

FIGURE 2-3: CIRCLE GESTURES



A circular gesture is a round-shaped hand movement defined by direction (clockwise/counterclockwise) without any specific start position of the user's hand. Two types of circular gestures are distinguished by GestIC technology:

1. Discrete Circles

Discrete Circles are recognized after performing a hand movement inside the sensing area. The recognition result (direction: clockwise/counterclockwise) is provided after the hand movement stops or the hand exits the detection area. The Discrete Circles are typically used as dedicated application control commands.

2. AirWheel

An AirWheel is the recognition of continuously-performed circles inside the sensing area and provides information about the rotational movement in real time. It provides continuously counter information which increments/decrements according to the movement's direction (clockwise/counterclockwise). The AirWheel can be adjusted for convenient usage in various applications (e.g., volume control, sensitivity adjustment or light dimming).

- **Sensor Touch Gestures**

FIGURE 1: SENSOR TOUCH GESTURES



A Sensor Touch is a multi-zone gesture that reports up to five concurrently-performed touches on the system's electrodes.

The Sensor Touch provides information about touch and tapping:

1. Touch

The Sensor Touch indicates an event during which a GestIC electrode is touched. This allows distinction between short and long touches.

2. Tap and Double Tap

The Tap and Double Tap signalize short taps and double taps on each system electrode. The tap length and double tap interval are adjustable.

- Single Tap Delay: A single tap is detected when touching the surface of an electrode first and after the hand is pulled out of the touch area. The Single Tap is only detected when the timing between the touch and the release of the touch event is smaller than the adjusted delay. Increasing the time allows the user more time to perform the tap. The range for the adjusted delay can be between 0s and 1s.
- Double Tap Delay: The double tap is detected when two taps are performed within the adjusted delay. The range for the adjusted delay can be between 0s and 1s. The smaller the selected delay is, the faster the two taps have to be executed.

FIGURE 2-4: SENSOR TOUCH DIAGRAM

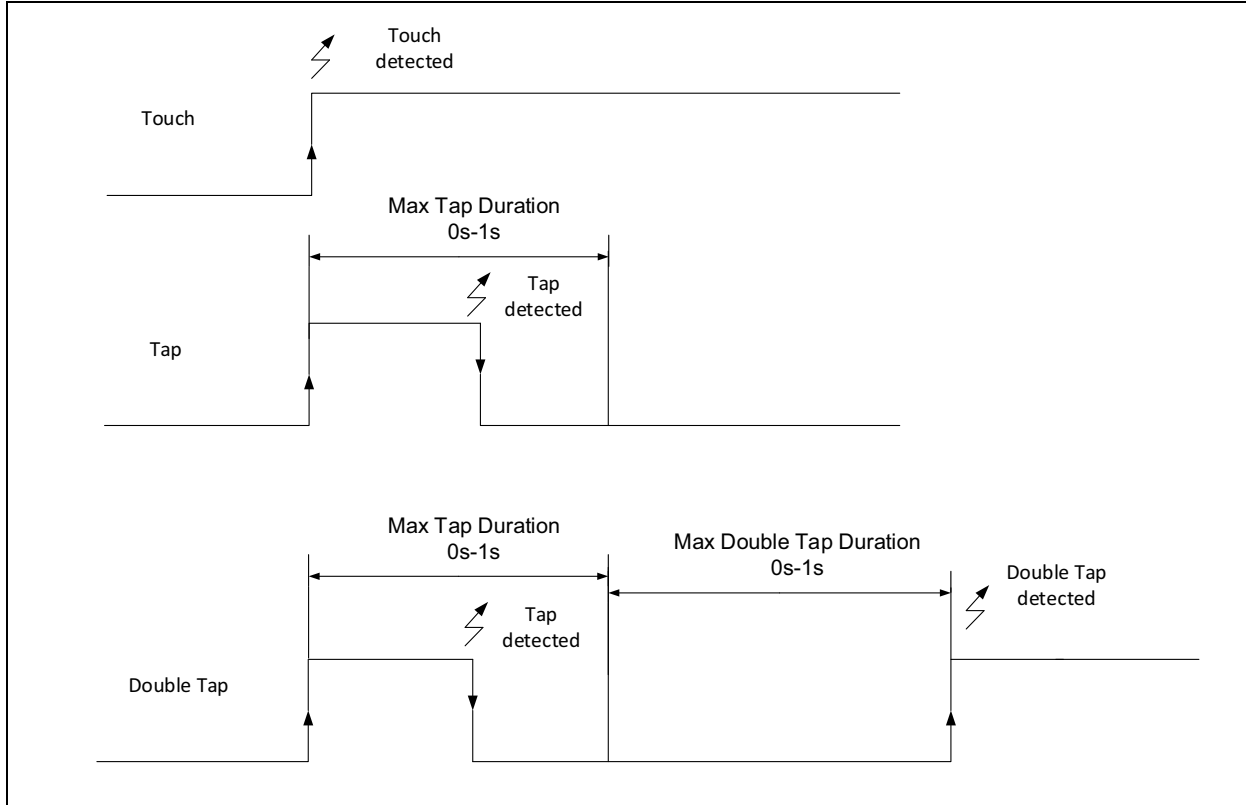

2.2.1.3 Gesture Port

FIGURE 2: GESTURE PORT



The Gesture Port enables a flexible mapping of Colibri Suite feature events to certain output signals at dedicated pins of the MGC3X30. The individual feature events can be mapped to one of five EIO Pins and trigger a variety of signal changes (Permanent high, Permanent low, Toggle, Pulse (100 ms), High Active, Low Active). The Gesture Port simplifies and enhances embedded system integration. It enables host-free integration based on EIOs.

2.2.1.4 Approach Detection

FIGURE 3: APPROACH DETECTION



Approach Detection is an embedded power-saving feature of Microchip’s Colibri Suite. It sends MGC3X30 to Sleep mode and scans periodically the sensing area to detect the presence of a human hand.

Utilizing the in-built Self Wake-up mode, Approach Detection alternates between Sleep and Scan phases. During the Scan phases, the approach of a human hand can be detected while very low power is consumed. For more details, please see [Section 4.2.4.3 “Self Wake-up Mode”](#).

A detected approach of a user exceeding configured threshold criteria will alternate the MGC3X30 from Self Wake-up to Processing mode or even the application host in the overall system.

Within the Approach Detection sequence, the following scans are performed:

- **Approach Scan:** An Approach scan is performed during the scan phase of the MGC3X30’s Self Wake-up mode. Typically, one Rx channel is active but more channels can be activated via the GestIC Library. The time interval (Scan Interval) between two consecutive Approach scans is

configurable. For typical applications, the scan cycle is in a range of 20 ms to 150 ms. During the Approach scan, the activated Rx channels are monitored for signal changes which are caused by, for example, an approaching human hand and exceeding the defined threshold. This allows an autonomous wake-up of the MGC3X30 and host applications at very low-power consumption.

- **Calibration Scan⁽¹⁾:** The Approach Detection feature includes the possibility to perform additional Calibration scans for the continuous adaptation of the electrode system to environmental changes.

A Calibration scan is performed during the scan phase of the MGC3X30’s Self Wake-up mode. Five Rx channels are active to calibrate the sensor signals. The Calibration scan is usually performed in configurable intervals from 2s to 1024s.

To reduce the power consumption, the number of scans per second can be decreased after a certain time of non-user activity. Colibri Suite provides a full user flexibility to configure the starting Calibration Scans rate (Calibration Start Scan Interval), non-user activity time-out (Calibration Transition Time) and the Calibration scans rate (Calibration Final Scan Interval) which will be used afterwards. A typical implementation uses Calibration scans every 2s during the first two minutes, and every 10s afterwards, until an approach is detected.

The timing sequence of the Approach Detection feature is illustrated in [Figure 2-5](#).

FIGURE 2-5: APPROACH DETECTION SEQUENCE

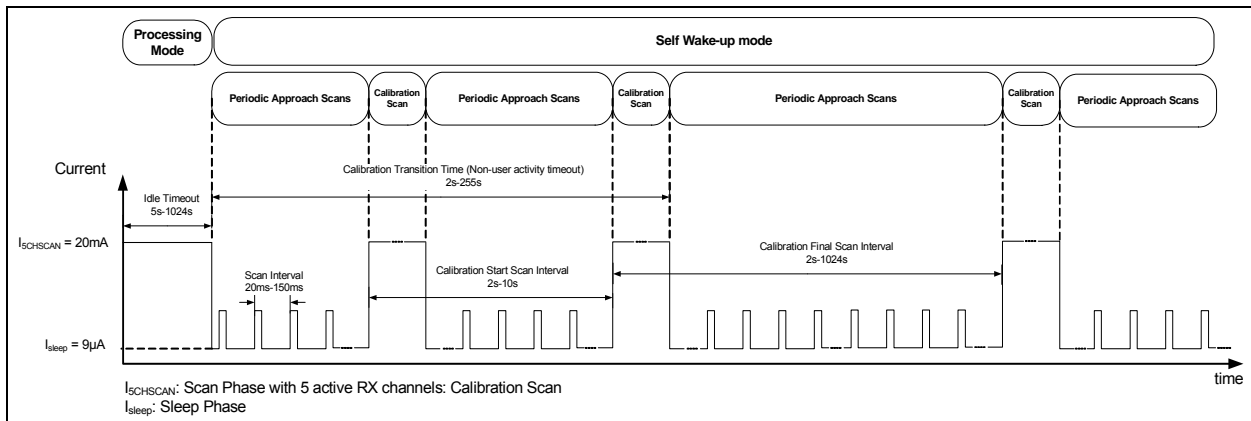

MGC3030/3130

3.0 SYSTEM ARCHITECTURE

MGC3X30 are mixed-signal configurable controllers. The entire system solution is composed of three main building blocks (see [Figure 3-1](#)):

- MGC3X30 Controller
- GestIC[®] Library
- External Electrodes

3.1 MGC3X30 Controller

The MGC3X30 feature the following main building blocks:

- Low Noise Analog Front End (AFE)
- Digital Signal Processing Unit (SPU)
- Communication Interfaces

The MGC3X30 provide a transmit signal to generate the E-field, conditions the analog signals from the receiving electrodes and processes these data digitally on the SPU. Data exchange between the MGC3X30 and the host is conducted via the controller's communication interface or the Gesture Port. For details, please refer to [Section 4.0 "Functional Description"](#).

3.2 GestIC[®] Library

The embedded GestIC Library is optimized to ensure continuous and real-time free-space Gesture Recognition and Motion tracking (MGC3130) concurrently. It is fully-configurable and allows required parameterization for individual application and external electrodes.

3.3 External Electrodes

Electrodes are connected to MGC3X30. An electrode needs to be individually designed following the guide lines from the 'GestIC Design Guide' for optimal E-field distribution and detection of E-field variations inflicted by a user.

FIGURE 3-1: MGC3X30 CONTROLLER SYSTEM ARCHITECTURE

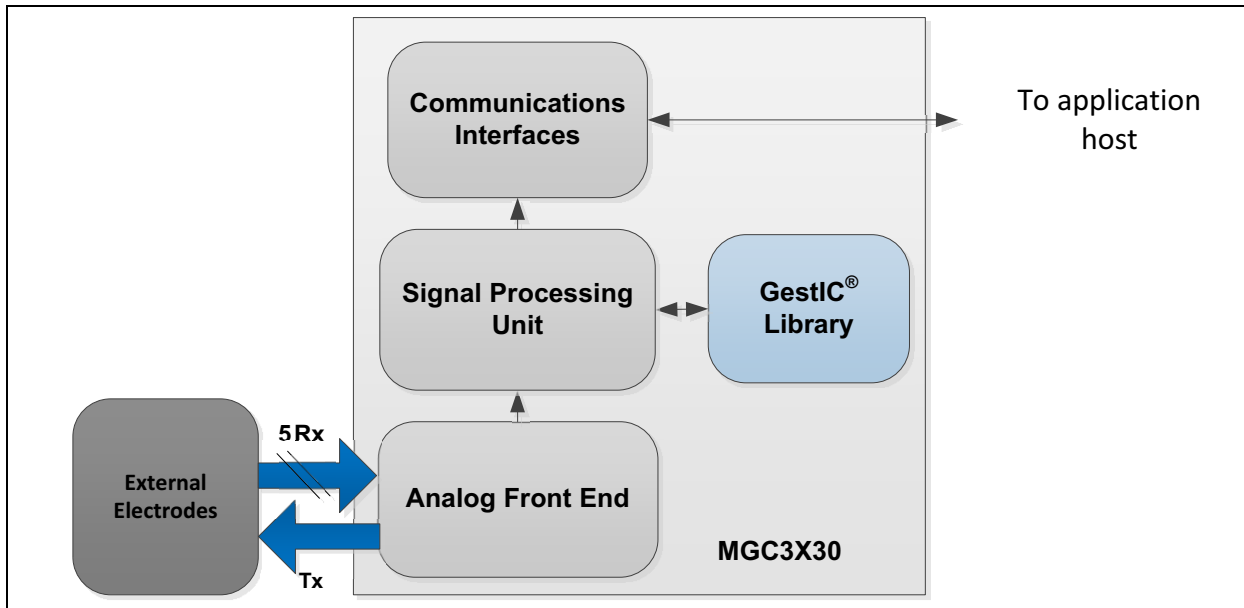

3.3.1 ELECTRODE EQUIVALENT CIRCUIT

The hand Position Tracking and Gesture Recognition capabilities of a GestIC system depends on the electrodes design and their material characteristics.

A simplified equivalent circuit model of a generic GestIC electrode system is illustrated in [Figure 3-2](#).

FIGURE 3-2: ELECTRODES CAPACITIVE EQUIVALENT CIRCUITRY EARTH GROUNDED

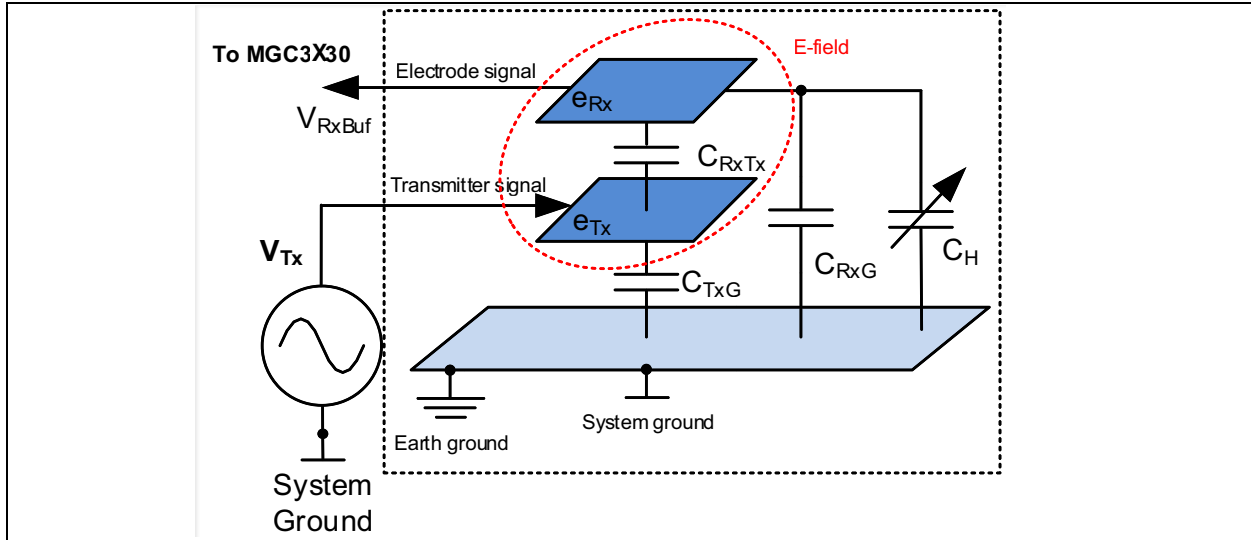

- V_{Tx} : Tx electrode voltage
- V_{RxBuf} : MGC3030 Rx input voltage
- C_H : Capacitance between receive electrode and hand (earth ground). The user's hand can always be considered as earth-grounded due to the comparable large size of the human body.
- C_{RxTx} : Capacitance between receive and transmit electrodes
- C_{RxG} : Capacitance of the receive (Rx) electrode to system ground + input capacitance of the MGC3030 receiver circuit
- C_{TxG} : Capacitance of the transmit (Tx) electrode to system ground
- e_{Rx} : Rx electrode
- e_{Tx} : Tx electrode

The Rx and Tx electrodes in a GestIC electrode system build a capacitance voltage divider with the capacitances C_{RxTx} and C_{RxG} which are determined by the electrode design. C_{TxG} represents the Tx electrode capacitance to system ground driven by the Tx signal. The Rx electrode measures the potential of the generated E-field. If a conductive object (e.g., a hand) approaches the Rx electrode, C_H changes its capacitance. This minuscule change in the femtofarad range is detected by the MGC3030 receiver.

The equivalent circuit formula for the earth-grounded circuitry is described in [Equation 3-1](#).

EQUATION 3-1: ELECTRODES EQUIVALENT CIRCUIT

$$V_{RxBuf} = V_{Tx} \times \frac{C_{RxTx}}{C_{RxTx} + C_{RxG} + C_H}$$

A common example of an earth-grounded device is a notebook, even with no ground connection via power supply or ethernet connection. Due to its larger form factor, it presents a high earth-ground capacitance in the range of 50 pF and thus, it can be assumed as an earth-grounded GestIC system.

A brief overview of the typical values of the electrodes capacitances is summarized in [Table 3-1](#).

TABLE 3-1: ELECTRODES CAPACITANCES TYPICAL VALUES

Capacity	Typical Value
C_{RxTx}	10...30 pF
C_{TxG}	10...1000 pF
C_{RxG}	10...30 pF
C_H	<1 pF

MGC3030/3130

Note: Ideal designs have low C_{RxTx} and C_{RxG} to ensure higher sensitivity of the electrode system. Optimal results are achieved with C_{RxTx} and C_{RxG} values being in the same range.

3.3.2 STANDARD ELECTRODE DESIGN

The MGC3X30 electrode system is typically a double-layer design with a Tx transmit electrode at the bottom layer to shield against device ground and thus, ensure high receive sensitivity. Up to five comparably smaller Rx electrodes are placed above the Tx layer providing the spatial resolution of the GestIC system. Tx and Rx

are separated by a thin isolating layer. The Rx electrodes are typically arranged in a frame configuration as shown in Figure 3-3. The frame defines the inside sensing area with maximum dimensions of 14x14 centimeters. An optional fifth electrode in the center of the frame may be used to improve the distance measurement and add simple touch functionality.

The electrodes' shapes can be designed solid or structured. In addition to the distance and the material between the Rx and Tx electrodes, the shape structure density also controls the capacitance C_{RxTx} and thus, the sensitivity of the system.

FIGURE 3-3: FRAME SHAPE ELECTRODES

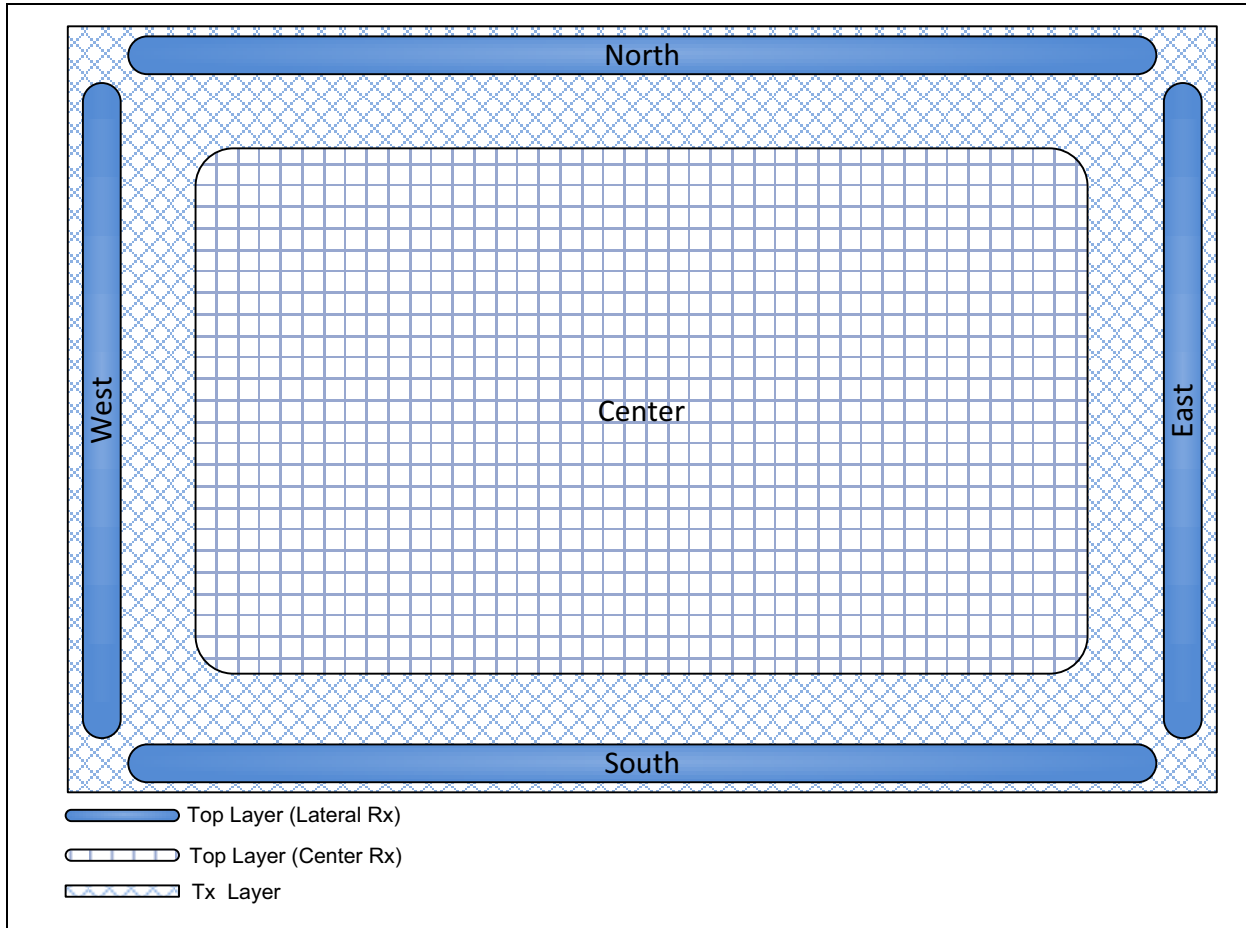

4.0 FUNCTIONAL DESCRIPTION

Microchip Technology's MGC3X30 configurable controller uses up to five E-field receiving electrodes. Featuring a Signal Processing Unit (SPU), a wide range of 3D gesture applications are being pre-processed on the MGC3X30, which allows short development cycles, as no host processing is needed.

Always-on 3D sensing, even for battery-driven mobile devices, is enabled due to the chip's low-power design and variety of programmable power modes. A Self Wake-up mode triggers interrupts to the application host reacting to interaction of a user with the device and supporting the host system in overall power reduction.

The MGC3X30 offers one enhanced I²C™ interface including SDA, SCL and TS line (EIO0) for data exchange with a host controller.

GestIC® sensing electrodes are driven by a low-voltage signal with a frequency in the range of 100 kHz, which allows their electrical conductive structure to be made of any low-cost material. Even the reuse of existing conductive structures, such as a display's ITO coating, is feasible, making the MGC3X30 an overall, very cost-effective system solution.

Figure 4-1 provides an overview of the main building blocks of MGC3X30. These blocks will be described in the following sections.

FIGURE 4-1: MGC3X30 CONTROLLER BLOCK DIAGRAM

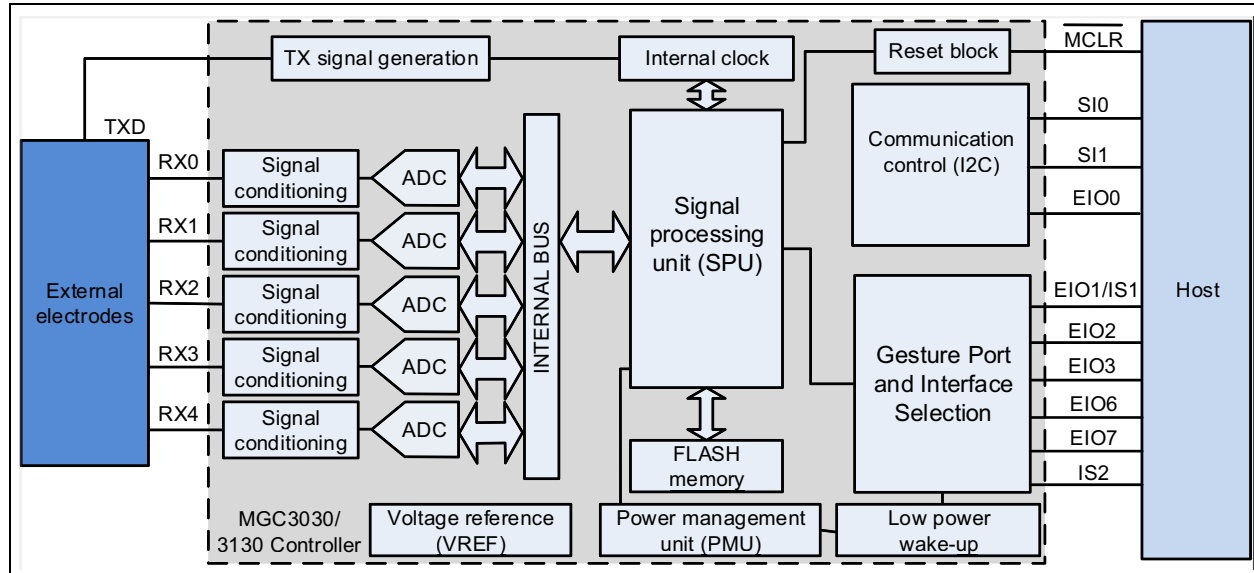

MGC3030/3130

4.1 Reset Block

The Reset block combines all Reset sources. It controls the device system's Reset signal (SYSRST). The following is a list of device Reset sources:

- **MCLR**: Master Clear Reset pin
- **SWR**: Software Reset available through GestIC Library Loader
- **WDTR**: Watchdog Timer Reset

A simplified block diagram of the Reset block is illustrated in [Figure 4-2](#).

FIGURE 4-2: SYSTEM RESET BLOCK DIAGRAM

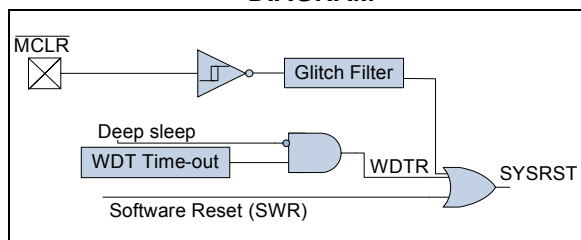

4.2 Power Control and Clocks

4.2.1 POWER MANAGEMENT UNIT (PMU)

The device requires a $3.3V \pm 5\%$ supply voltage at VDD.

According to [Figure 4-3](#), the used power domains are as follows:

- **VDD Domain**: This domain is powered by $VDD = 3.3V \pm 5\%$ (typical $VDD = 3.3V$). VDD is the external power supply for EIO, wake-up logic, WDTR and internal regulators.
- **VDDC Domain**: This domain is powered by $VDDC = 1.8V$. It is generated by an embedded low-impedance and fast linear voltage regulator. The voltage regulator is working under all conditions (also during Deep Sleep mode) preserving the MGC3X30 data context. VDDC is the internal power supply voltage for digital blocks, Reset block and RC oscillators. An external block capacitor, CEFC, is required on VCAPD pin.

- **VDDA Domain**: This domain is powered by $VDDA = 3.0V$. It is generated by an embedded low-impedance and fast linear voltage regulator. During Deep Sleep mode, the analog voltage regulator is switched off. VDDA is the internal analog power supply voltage for the ADCs and the signal conditioning. An external block capacitor, CEFA, is required on VCAPA pin.
- **VDDM Domain**: This domain is powered by $VDDM = 3.3V$. VDDM is the internal power supply voltage for the internal Flash memory. VDDM is directly powered through $VDD=3.3V$.

FIGURE 4-3: POWER SCHEME BLOCK DIAGRAM

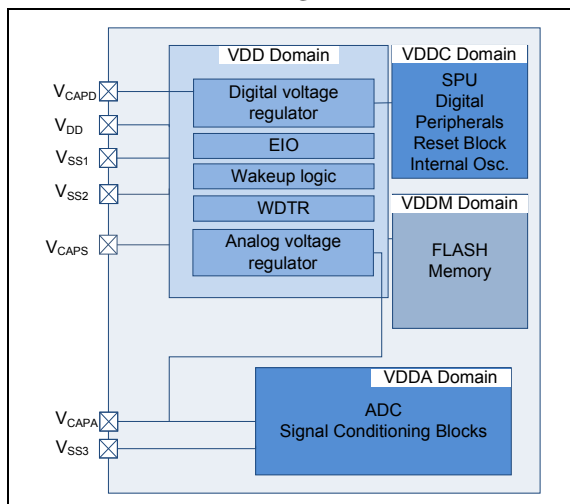

4.2.2 POWER SUPERVISORS

During the Power-up sequence, the system is kept under Reset condition for approximately 200 μs (Reset delay: t_{RSTDLY}) after the $V_{\text{DD}} = 1.5\text{V}$ voltage is reached (1.2V minimum). During this delay, the system Reset will remain low and the V_{DD} should reach typically 2V.

When the Reset delay is elapsed, the system Reset is released (high) and the system starts the Power-up/Time-out (t_{PWRT}) sequence. The system start depends on the used V_{DD} voltage. The Power-up/Time-out period (t_{PWRT}) after Reset takes 36 LSO cycles. (see [Table 4-3](#)).

The system starts when (see [Figure 4-4](#)):

- Power-up/Time-out period (t_{PWRT}) is elapsed
- $V_{\text{DD}} = 3.3\text{V}$ is already reached before the end of t_{PWRT} timing

The power-up sequence begins by increasing the voltage on the V_{DD} pin (from 0V). If the slope of the V_{DD} rise time is faster than 4.5 V/ms, the system starts correctly.

If the slope is less than 4.5 V/ms, the $\overline{\text{MCLR}}$ pin must be held low, by external circuitry, until a valid operating V_{DD} level is reached.

FIGURE 4-4: POWER SUPERVISORS

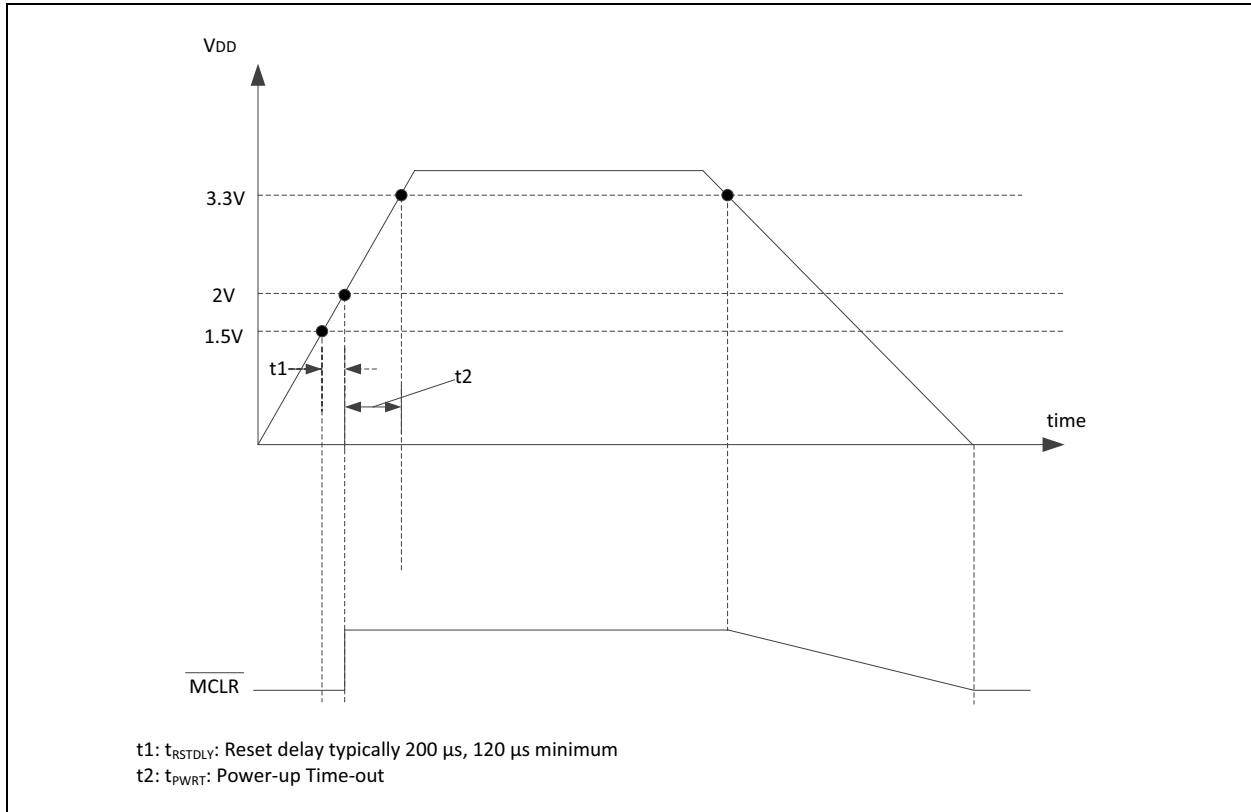

4.2.3 CLOCKS

The MGC3X30 is embedding two internal oscillators, high speed and low speed. The High-Speed Oscillator (HSO) is factory-trimmed, achieving high accuracy.

- **High-Speed Oscillator (HSO):**

The MGC3X30 is clocked by an internal HSO running at 22.5 MHz \pm 10% and consuming very low power. This clock is used to generate the Tx signal, to trigger the ADC conversions and to run the SPU. During Deep Sleep mode, the HSO clock is switched off.

- **Low-Speed Oscillator (LSO):**

This low-speed and ultra-low-power oscillator is typically 32 kHz with a tolerance of \pm 10 kHz. It is used during power-saving modes.

4.2.4 OPERATION MODES

MGC3X30 offers three operation modes that allow the user to balance power consumption with device functionality. In all of the modes described in this section, power saving is configured by GestIC Library messages.

4.2.4.1 Processing Mode

In this mode, all power domains are enabled and the SPU is running continuously. All peripheral digital blocks are active. Gesture Recognition and Position Tracking require the Processing Operation mode.

4.2.4.2 Deep Sleep Mode

During the Deep Sleep mode, VDDM and VDDA are turned off, and VDDC is still powered to retain the data of the SPU.

The mode includes the following characteristics:

- The SPU is halted
- The High-Speed Oscillator is shut down
- The Low-Speed Oscillator is running
- The Watchdog is switched off
- Host interface pins are active for wake-up

This leads to the lowest possible power consumption of MGC3X30.

The MGC3X30 will resume from Deep Sleep if one of the following events occurs:

- External Interrupt (IRQ0) or I²C0 Start Bit Detection
- On $\overline{\text{MCLR}}$ Reset

The Deep Sleep mode can be enabled by GestIC Library messages.

4.2.4.3 Self Wake-up Mode

The Self Wake-up mode is a Low-Power mode allowing an autonomous wake-up of the MGC3X30 and application host. In this mode, the MGC3X30 is automatically and periodically alternating between Sleep and Scan phases.

The MGC3X30's fast wake-up, typically below 1 ms, allows to perform scans in very efficient periods and to maximize the Sleep phase.

The periodic Wake-up sequence is triggered by a programmable wake-up timer running at LSO frequency and which can be adjusted by the Approach Detection feature.

The MGC3X30 enters the Self Wake-up mode by a GestIC Library message or by a non-activity time-out. Non-activity means no user detection within the sensing area.

The MGC3X30 will resume from Self Wake-up on one of the following events:

- Wake-up timer overflow event
- External Interrupt (IRQ0) or I²C0 Start Bit detection
- On $\overline{\text{MCLR}}$ or WDTR

4.2.4.4 MGC3X30 Power Profile

The MGC3X30 power profile is illustrated in [Figure 4-5](#).

FIGURE 4-5: MGC3X30 POWER PROFILE

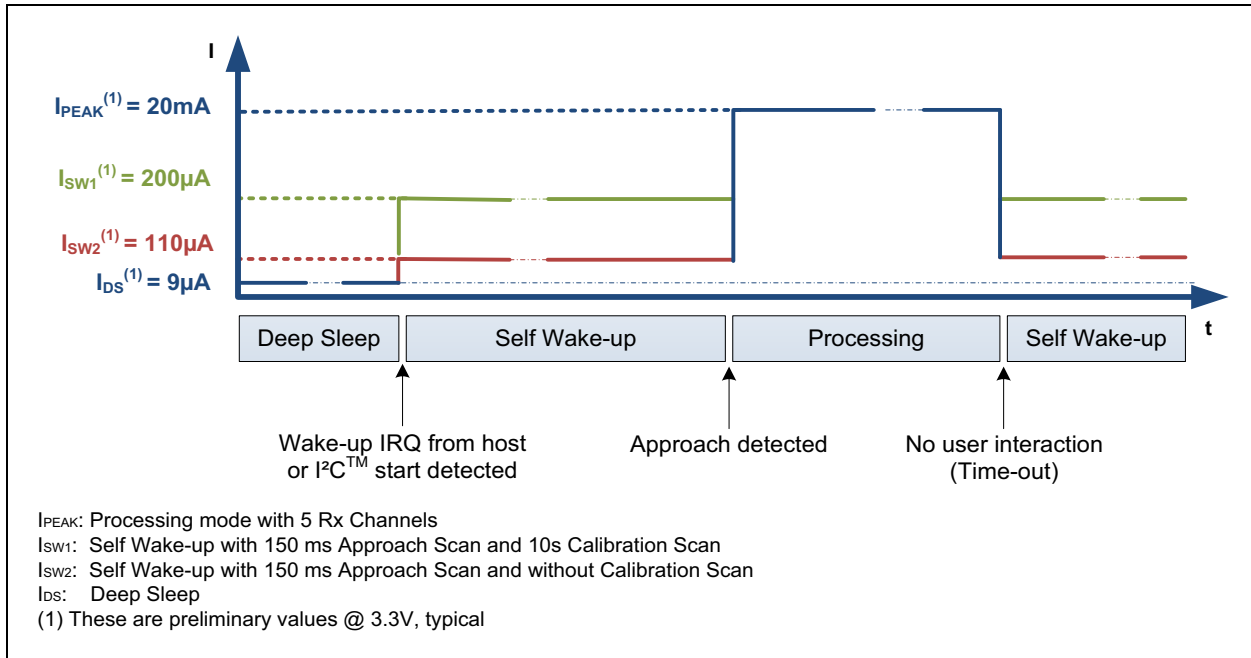

MGC3X30 current consumption for the different operation modes are summarized in [Table 4-1](#).

TABLE 4-1: CURRENT CONSUMPTION OVERVIEW

Mode	Current Consumption	Conditions
Processing mode	20 mA	V _{DD} = 3.3V 5 Rx Channels activated
Self Wake-up mode	110 µA	V _{DD} = 3.3V No Calibration Scan 1 Rx Channel active
	200 µA	V _{DD} = 3.3V Calibration Scan each 10s 1 Rx Channel active
Deep Sleep mode	9 µA	V _{DD} = 3.3V

Note: In Processing mode, there are always five Rx channels activated. Choosing only four Rx channels in Aurea does not have an impact on the current consumption during Processing mode.

The Self Wake-up mode current consumption depends on the number of active channels during Self Wake-up mode, Approach Scan and Calibration Scan repetition period. Changing these parameters results in different current consumption values.

MGC3030/3130

Figure 4-6 and Figure 4-7 describe the Self Wake-up mode current consumption according to the Approach Scan and Calibration Scan period change.

FIGURE 4-6: CURRENT CONSUMPTION FOR VARYING TIME INTERVALS BETWEEN APPROACH SCANS AND CALIBRATION SCANS

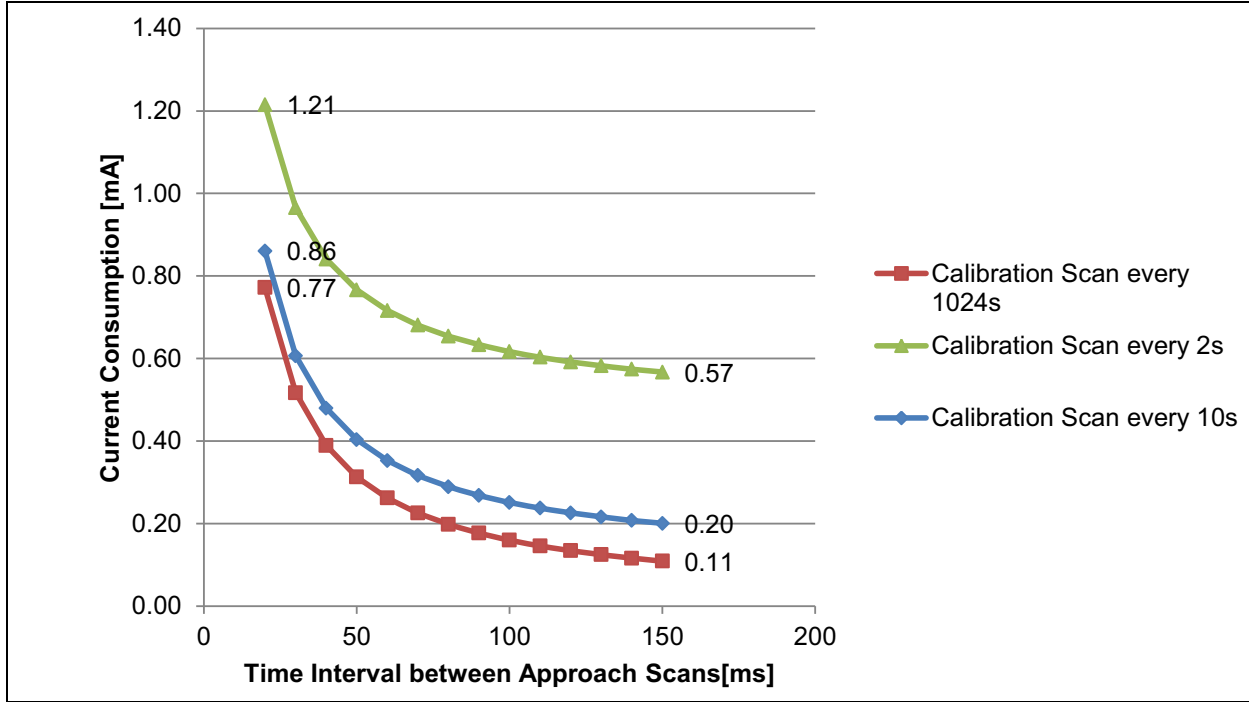
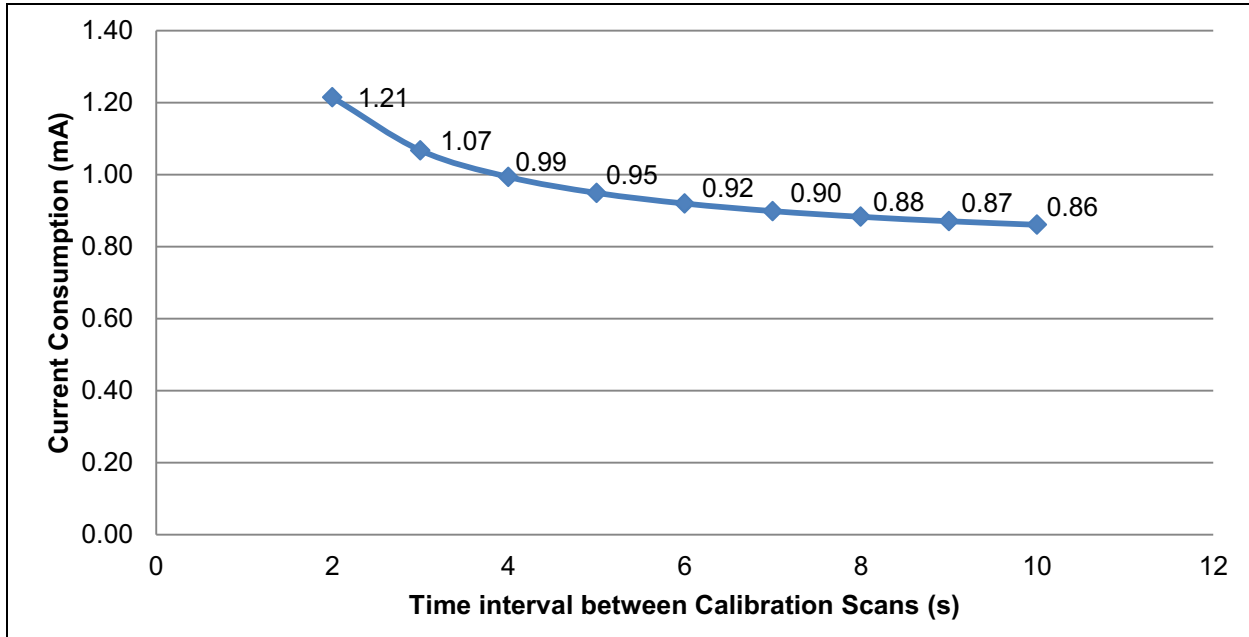

FIGURE 4-7: CURRENT CONSUMPTION FOR A FIXED TIME INTERVAL BETWEEN APPROACH SCANS OF 20 ms



4.2.4.5 Operation Modes Summary

Table 4-2 summarizes the MGC3X30 operation modes.

TABLE 4-2: OPERATION MODES SUMMARY

Mode	Entry	Exit	Comments
Processing	I ² C™0/IRQ0/Approach/ MCLR/WDTR/SW Reset	GestIC® Library Message/Non- Activity Time-out/WDTR	- Processing mode with up to five electrodes continuously running - Full positioning and Gesture Recognition capabilities
Self Wake-up	Time-out/GestIC® Library Message	I ² C™0/IRQ0/Wake-up Timer/ MCLR/WDTR	- Scan phase with a configurable number of Rx active channels, wake-up timer is used to resume the system - Approach detection capability - Fast wake-up time - Very low-power consumption
Deep Sleep	GestIC® Library Message	I ² C™0/IRQ0/MCLR	- SPU halted, Analog Voltage Regulator OFF, Watchdog OFF - No positioning or gesture detection - Extreme low-power consumption - Needs trigger from application host to switch into Self Wake-up or Processing mode

4.2.5 POWER-UP/DOWN SEQUENCE

Figure 4-8 represents the power-up sequence timings after a Reset or Deep Sleep state.

FIGURE 4-8: POWER-UP SEQUENCE TIMINGS

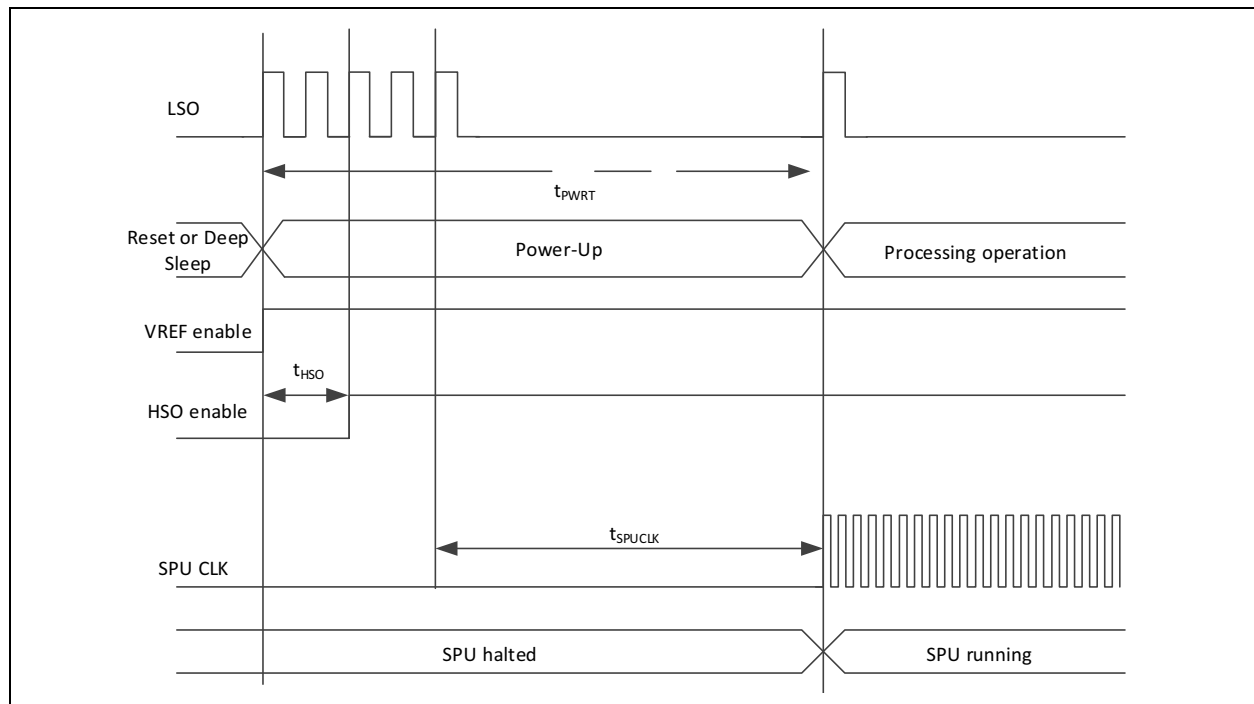

MGC3030/3130

Power-up Phases

- Reset or Deep Sleep: The system is kept in Reset or is in Deep Sleep mode
- Power-up: Phase when the system starts up after Reset/Deep Sleep has been released
- Processing operation: Processing mode is started
- Power-up Time-out

TABLE 4-3: POWER-UP TIME-OUT (t_{PWRT})

Signal	Symbol	Delay in LSO Cycles	
		After Reset	After Deep Sleep
VREF Enable	t_{VREF}	0	0
HCO Enable	t_{HCO}	2	2
SPU CLK	t_{SPUCLK}	30	8
Power-Up Time-Out	t_{PWRT}	36	10

Signal References

- LSO: Low-Speed Oscillator clock
- HCO: High-Speed Oscillator clock
- VREF Enable: Voltage Reference enable signal
- HCO Enable: High-Speed Oscillator enable signal

Figure 4-9 illustrates the power-down sequence timings.

FIGURE 4-9: POWER-DOWN SEQUENCE TIMINGS

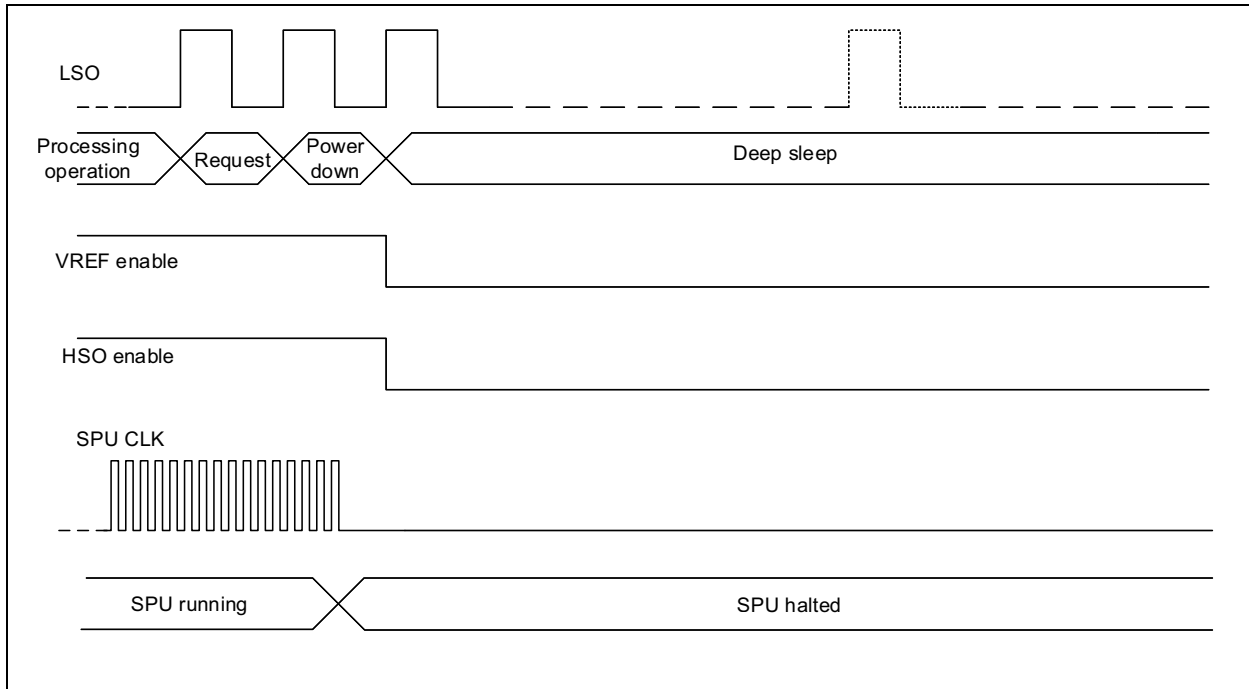

Power-down Phases

- Processing Operation: Processing mode is activated
- Request: Request to enter Deep Sleep mode
- Power-down: Power-down state (all analog signals are down)
- Deep Sleep: Deep Sleep mode has been entered

Signal References

- LSO: Low-Speed Oscillator clock
- HSO: High-Speed Oscillator clock
- VREF Enable: Voltage Reference enable signal
- HSO Enable: High-Speed Oscillator enable signal

4.3 Transmit Signal Generation

The Tx signal generation block provides a bandwidth limited square wave signal for the transmit electrode. Frequency hopping adjusts automatically the Tx carrier frequency in the range of 44-115 kHz, depending on the environmental noise conditions. GestIC Library automatically selects the lowest noise working frequency in case the sensor signal is compromised. Frequencies can be enabled/disabled via the GestIC Library.

4.4 Receive (Rx) Channels

There are five identical Rx channels that can be used for five respective receive electrodes. Four receive electrodes are required for Position Tracking and Gesture Recognition. A fifth electrode can be used for touch detection and to improve distance measurement. Each channel has its own analog signal conditioning stage, followed by a dedicated ADC. For specific features such as Approach Detection, individual Rx channels can be activated or deactivated via the GestIC Library. According to the electrode characteristics, the channels have to be parameterized.

The signal conditioning block contains analog filtering and amplification as shown in [Figure 4-10](#).

For individual electrode characteristics, the Rx channels can be configured as follows:

- **Signal matching:** The received signal is sampled at a sampling rate, equal to twice the Tx frequency providing a high and low ADC sample. The signal matching block adjusts the received signal towards the same value of high and low ADC samples. The offset can be adjusted accordingly.
- **The matched signal** output is amplified using a programmable gain amplifier to achieve a better sensitivity.

4.5 Analog-to-Digital Converter (ADC)

As outlined in [Section 4.4 “Receive \(Rx\) Channels”](#), each Rx channel features a dedicated ADC with a trigger derived from the internal clock. ADC samples are synchronous with twice the Tx transmit frequency.

4.6 Signal Processing Unit (SPU)

The MGC3X30 features a Signal Processing Unit (SPU) to control the hardware blocks and process the advanced DSP algorithms included in the GestIC Library. It provides filtered sensor data, continuous position information and recognized gestures to the application host. The host combines the information and controls its application.

4.7 Parameters Storage

The MGC3X30 provides an embedded 32 kBytes Flash memory which is dedicated for the GestIC Library and storage of the individual configuration parameters. These parameters have to be set according to the individual electrode design and application. The GestIC Library and parameters are loaded into MGC3X30 with the provided software tools or, alternatively, via GestIC Library messages by the application host. For more details on the MGC3X30 tools, please refer to [Section 7.0 “Development Support”](#).

FIGURE 4-10: SIGNAL CONDITIONING BLOCK

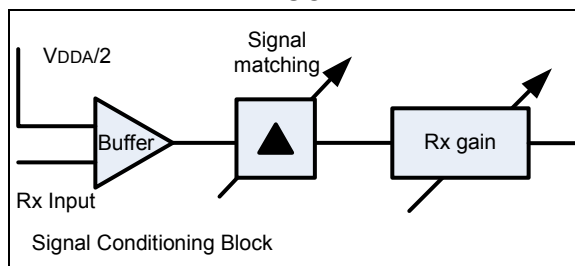

MGC3030/3130

5.0 INTERFACE DESCRIPTION

The MGC3X30 supports an I²C™ interface with Slave mode and the Gesture Port (five configurable EIOs).

5.1 Interface Selection

The MGC3X30 interface selection pin, IS2, is used to select the I²C slave address. There are two different addresses.

TABLE 5-1: MGC3X30 INTERFACE SELECTION PINS

IS2	IS1	Mode (Address)
0	0	I ² C™0 Slave Address 1 (0x42)
1	0	I ² C™0 Slave Address 2 (0x43)

5.2 Extended Input Output (EIO)

The MGC3X30 provides input/output pins with extended features. These pins are controlled by GestIC® Library and listed in [Table 5-2](#).

TABLE 5-2: MGC3X30 EXTENDED IOS FUNCTIONS

Pin	Multiplexed Functions
EIO0	TS
EIO1	IS1/Gesture Port
EIO2	IRQ0/Gesture Port
EIO3	IRQ1/SYNC/Gesture Port
EIO4	SDA0
EIO5	SCL0
EIO6	Gesture Port
EIO7	Gesture Port

5.3 Interrupt Requests

MGC3X30 IRQ0 and IRQ1 interrupt lines are used by the host to wake-up the MGC3X30 from Deep Sleep and Self Wake-up modes. If a wake-up event is detected on IRQ0 or IRQ1 lines, the MGC3X30 switches to the Processing mode.

5.4 Gesture Port

The MGC3X30 provides five output pins which can be used to output the Colibri Suite features events. These pins are controlled by GestIC Library to signal that an event occurred. The host does not need to monitor the I²C bus to get GestIC Library events, but only has to monitor the Gesture Port pins. This feature is used in parallel to I²C communication.

The Colibri Suite Gesture Port feature mapping is illustrated in [Figure 5-1](#).

FIGURE 5-1: GESTURE PORT MAPPING

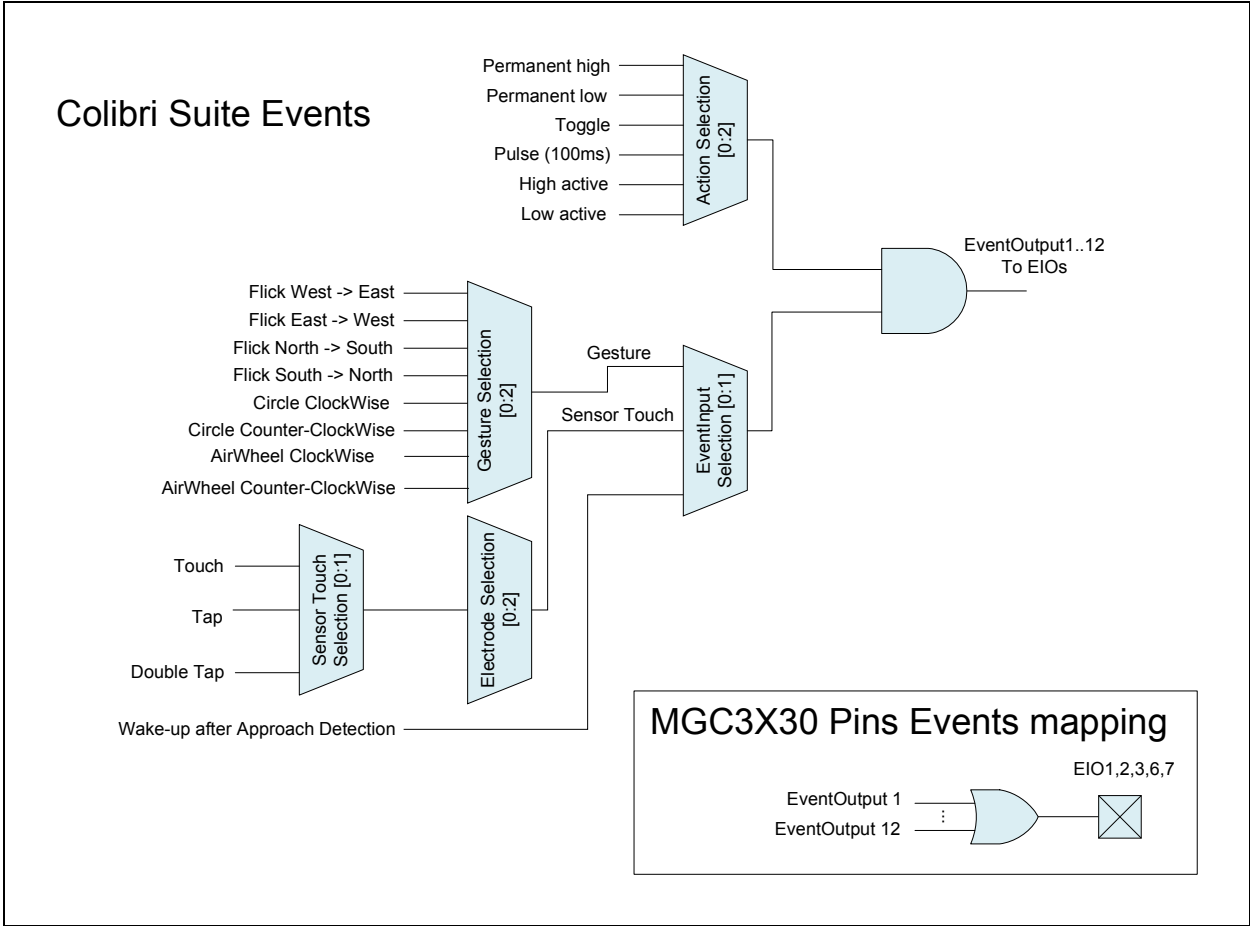

The Colibri Suite can generate up to twelve event outputs which can be mapped to any EIO (1, 2, 3, 6 or 7). It is also possible to map more than one event output by one EIO.

TABLE 5-3: COLIBRI SUITE EVENTS

Gesture Port Mapping Parameter	Description
Gesture Selection	Selects the gestures which will be used as event. Gesture Selection can be: <ul style="list-style-type: none">• Flick West/East• Flick East/West• Flick North/South• Flick South/North• Circle Clockwise• Circle Counterclockwise• AirWheel Clockwise• AirWheel Counterclockwise
Sensor Touch Selection	Selects the sensor touch which will be used as event. Sensor Touch Selection can be: <ul style="list-style-type: none">• Touch• Tap• Double Tap
Electrode Selection	Selects the electrode which will be used for Sensor Touch. Electrode Selection can be: <ul style="list-style-type: none">• West• East• North• South• Center
Event Input Selection	Selects the event which will trigger an event output on the EIOs. Event Input Selection can be: <ul style="list-style-type: none">• Gesture• Sensor Touch• Wake-up after Approach Detection
Action Selection	Selects the signal format which will be output on the EIOs. See Figure 5-2 and Table 5-4 . Action Selection can be: <ul style="list-style-type: none">• Permanent High• Permanent Low• Toggle• Pulse• High Active• Low Active

FIGURE 5-2: GESTURE PORT ACTION

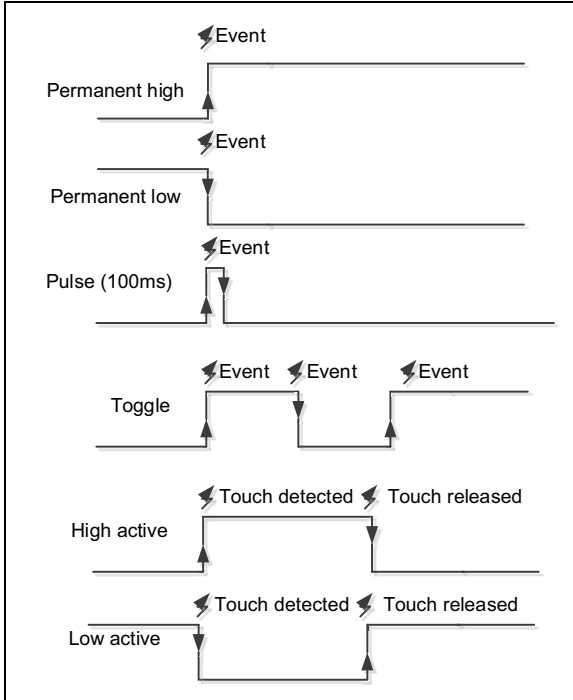

TABLE 5-4: GESTURE PORT MAPPING

Event	Action					
	Permanent High	Permanent Low	Toggle	Pulse	High Active	Low Active
Gesture	X	X	X	X		
Touch			X	X	X	X
Single Tap	X	X	X	X		
Double Tap	X	X	X	X		
Approach					X	X
AirWheel				X		

MGC3030/3130

5.5 Communication Interfaces

5.5.1 I²C™

The MGC3X30 offer an I²C™ interface for communicating with an application host. The I²C0 port offers:

- Slave mode
- Up to 400 kHz
- 7-bit Addressing mode
- Hardware state machine for basic protocol handling
- Support for repeated start and clock stretching (Byte mode)
- No multi-master support

I²C™ Hardware Interface

A summary of the hardware interface pins is shown below in [Table 5-5](#).

TABLE 5-5: I²C™ PIN DESCRIPTION

MGC3X30 Pin	Multiplexed Functions
SCL	Serial Clock to Master I ² C™
SDA	Serial Data to Master I ² C™

- SCL Pin
 - The SCL (Serial Clock) pin is electrically open-drain and requires a pull-up resistor of typically 1.8 kΩ (for a maximum bus load capacitance of 200 pF), from SCL to VDD.
 - SCL Idle state is high.
- SDA Pin
 - The SDA (Serial Data) pin is electrically open-drain and requires a pull-up resistor of typically 1.8 kΩ (for a maximum bus load capacitance of 200 pF), from SDA to VDD.
 - SDA Idle state is high.
 - Master write data is latched in on SCL rising edges.
 - Master read data is latched out on SCL falling edges to ensure it is valid during the subsequent SCL high time.

I²C™ Addressing:

The MGC3X30 Device ID 7-bit address is: 0x42 (0b1000010) or 0x43 (0b1000011) depending on the interface selection pin configuration (IS2+IS1). Please refer to [Table 5-6](#).

TABLE 5-6: I²C™ DEVICE ID ADDRESS

Device ID Address, 7-bit						
A6	A5	A4	A3	A2	A1	A0
1	0	0	0	0	1	IS2

TABLE 5-7: I²C™ DEVICE WRITE ID ADDRESS (0x84 OR 0x86)

I ² C™ Device Write ID Address							
A7	A6	A5	A4	A3	A2	A1	A0
1	0	0	0	0	1	IS2	0

TABLE 5-8: I²C™ DEVICE READ ID ADDRESS (0x85 OR 0x87)

I ² C™ Device Read ID Address							
A7	A6	A5	A4	A3	A2	A1	A0
1	0	0	0	0	1	IS2	1

I²C™ Master Read Bit Timing

Master read is to receive position data, gesture reports and command responses from the MGC3X30. The timing diagram is shown in [Figure 5-4](#).

- Address bits are latched into the MGC3X30 on the rising edges of SCL.
- Data bits are latched out of the MGC3X30 on the rising edges of SCL.
- ACK bit:
 - MGC3X30 presents the ACK bit on the ninth clock for address acknowledgment
 - I²C master presents the ACK bit on the ninth clock for data acknowledgment
- The I²C master must monitor the SCL pin prior to asserting another clock pulse, as the MGC3X30 may be holding off the I²C master by stretching the clock.

I²C™ Communication Steps

1. SCL and SDA lines are Idle high.
2. I²C master presents Start bit to the MGC3X30 by taking SDA high-to-low, followed by taking SCL high-to-low.
3. I²C master presents 7-bit address, followed by a R/W = 1 (Read mode) bit to the MGC3X30 on SDA, at the rising edge of eight master clock (SCL) cycles.
4. MGC3X30 compares the received address to its Device ID. If they match, the MGC3X30 acknowledges (ACK) the master sent address by presenting a low on SDA, followed by a low-high-low on SCL.
5. I²C master monitors SCL, as the MGC3X30 may be clock stretching, holding SCL low to indicate that the I²C master should wait.

6. I²C master receives eight data bits (MSB first) presented on SDA by the MGC3X30, at eight sequential I²C master clock (SCL) cycles. The data is latched out on SCL falling edges to ensure it is valid during the subsequent SCL high time.
7. If data transfer is not complete, then:
 - I²C master acknowledges (ACK) reception of the eight data bits by presenting a low on SDA, followed by a low-high-low on SCL.
 - Go to step 5.
8. If data transfer is complete, then:
 - I²C master acknowledges (ACK) reception of the eight data bits and a completed data transfer by presenting a high on SDA, followed by a low-high-low on SCL.

I²C™ Master Write Bit Timing

I²C master write is to send supported commands to the MGC3X30. The timing diagram is shown in [Figure 5-5](#).

- Address bits are latched into the MGC3X30 on the rising edges of SCL.
- Data bits are latched into the MGC3X30 on the rising edges of SCL.
- ACK bit:
 - MGC3X30 presents the ACK bit on the ninth clock for address acknowledgment
 - I²C master presents the ACK bit on the ninth clock for data acknowledgment
- The master must monitor the SCL pin prior to asserting another clock pulse, as the MGC3X30 may be holding off the master by stretching the clock.

I²C™ Communication Steps

1. SCL and SDA lines are Idle high.
2. I²C master presents Start bit to the MGC3X30 by taking SDA high-to-low, followed by taking SCL high-to-low.
3. I²C master presents 7-bit address, followed by a R/W = 0 (Write mode) bit to the MGC3X30 on SDA, at the rising edge of eight master clock (SCL) cycles.
4. MGC3X30 compares the received address to its Device ID. If they match, the MGC3X30 acknowledges (ACK) the I²C master sent address by presenting a low on SDA, followed by a low-high-low on SCL.
5. I²C master monitors SCL, as the MGC3X30 may be clock stretching, holding SCL low to indicate the I²C master should wait.
6. I²C master presents eight data bits (MSB first) to the MGC3X30 on SDA, at the rising edge of eight master clock (SCL) cycles.
7. MGC3X30 acknowledges (ACK) receipt of the eight data bits by presenting a low on SDA, followed by a low-high-low on SCL.
8. If data transfer is not complete, then go to step 5.
9. Master presents a Stop bit to the MGC3X30 by taking SCL low-high, followed by taking SDA low-to-high.

5.5.2 TRANSFER STATUS LINE

MGC3X30 requires a dedicated Transfer Status line (TS) which features a data transfer status function. It is used by both I²C Master and Slave to control data flow.

The TS (Transfer Status) line is electrically open-drain and requires a pull-up resistor of typically 10 kΩ, from TS to V_{DD}. TS Idle state is high.

The MGC3X30 (I²C Slave) uses this line to inform the host controller (I²C Master) that there is data available which can be transferred. The host controller uses the TS line to indicate that data is being transferred and prevents MGC3X30 from updating its data buffer.

[Table 5-9](#) shows how the TS line is used in the different states of communication.

MGC3030/3130

TABLE 5-9: USAGE OF TRANSFER STATUS LINE

MGC3X30	Host Controller	TS Line	Status
Released (H)	Released (H)	High	Host finished reading data (Transfer end). No more data to be transferred to the host. MGC3X30 is allowed to update the data buffer.
Asserted (L)	Released (H)	Low	Data from MGC3X30 is available to be sent, but the host has not yet started reading. If the host is busy and did not start reading before the next data update (5 ms), the MGC3X30 will assert the TS line high while updating the data buffer.
Asserted (L)	Asserted (L)	Low	Host starts reading. MGC3X30 data buffer will not be updated until the end of transfer (host releases TS high).
Released (H)	Asserted (L)	Low	MGC3X30 is ready to update the data buffer, but the host is still reading the previous data. MGC3X30 is allowed to update the data only when the host releases the TS high.

MGC3X30 can update the I²C buffer only when the TS is released by both chips and a data transfer can only be started when MGC3X30 pulls the TS low.

This procedure secures that:

- the host is always informed when new sensor data is available
- buffer updates in MGC3X30 are always completed before data is sent to the I²C bus

Figure 5-3 shows the complete communication protocol.

FIGURE 5-3: MGC3X30 COMMUNICATION PROTOCOL

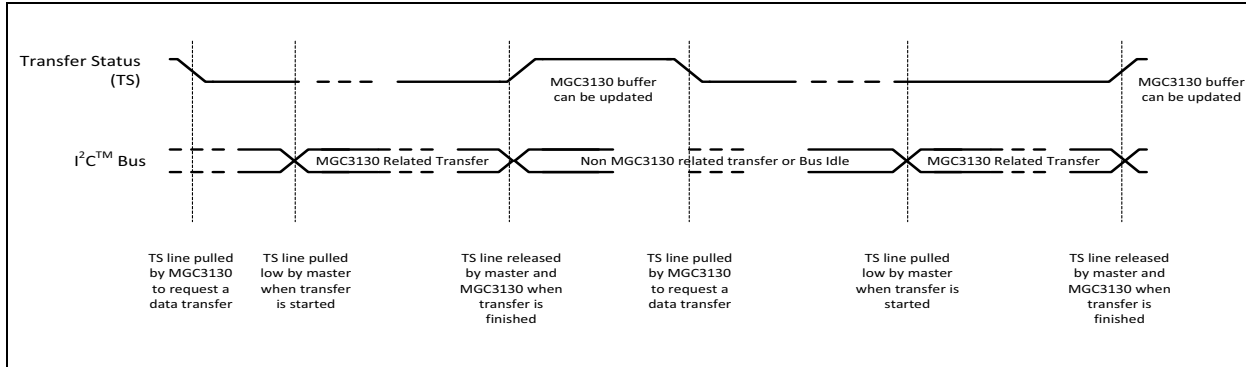

Note 1: The stop condition after an I²C™ data transmission is generated by the host controller (I²C™ Master) after the data transfer is completed. Thus, it is recommended to verify the amount of bytes to be read in the message header (Size field).

2: Transfer Status is only needed for data transfer from MGC3X30 to the host controller. Writing to MGC3X30 does not require the additional TS signal.

In addition to the standard I²C interface, the communication between MGC3X30 and the host controller requires a proper handling of the Transfer Status.

FIGURE 5-4: I²C™ MASTER READ BIT TIMING DIAGRAM

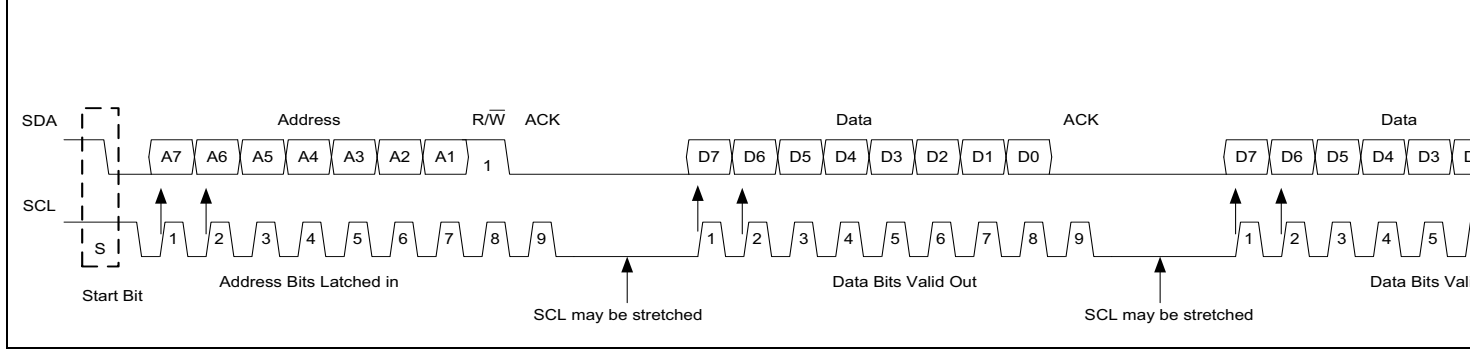
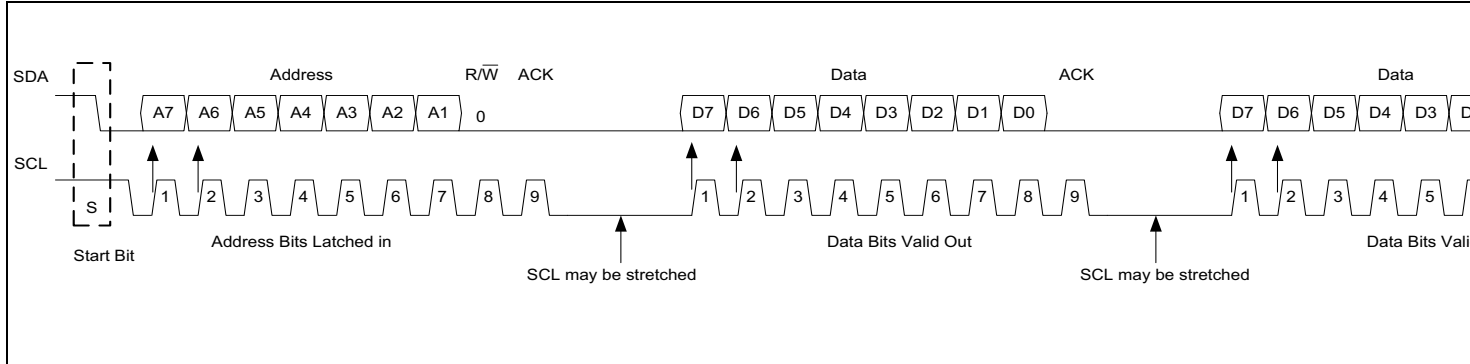

FIGURE 5-5: I²C™ MASTER WRITE BIT TIMING DIAGRAM



MGC3030/3130

6.0 APPLICATION ARCHITECTURE

The standard MGC3X30 implementation is a single-zone design. This configuration is based on one MGC3X30 connected to an application host via I²C™ with MGC3X30 being Slave and Application Host being Master. The following lines are needed for full I²C communication (see Figure 6-1).

Data reporting and flow-control scenarios are described below for I²C communication:

- SDA
- SCL
- EIO0 (Transfer Status Line) is toggled indicating that new data is available and checking whether the host has already started data reading or not.

6.4 Reference Schematic (3.3V ≤ VDD ≤ 3.465V)

The reference application schematic for the MGC3X30 is depicted below in Figure 6-2.

FIGURE 6-1: APPLICATION CIRCUITRY

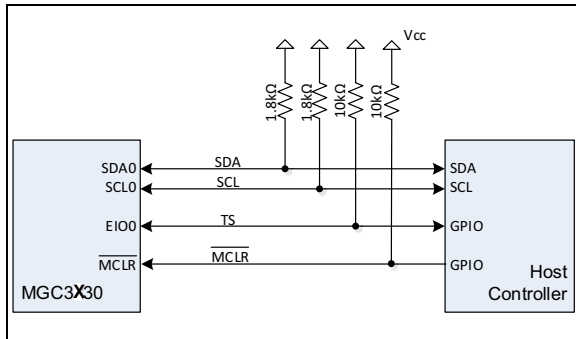

6.1 ESD Considerations

The MGC3X30 provides Electrostatic Discharge (ESD) Voltage protection up to 2 kV (HBM). Additional ESD countermeasures may be implemented individually to meet application-specific requirements.

6.2 Power Noise Considerations

MGC3X30 filtering capacitors are included in the reference design schematic (Please refer to Figure 6-2).

6.3 Irradiated High-Frequency Noise

In order to suppress irradiated high-frequency signals, the five Rx channels of the chip are connected to the electrodes via serial 10 kΩ resistors, as close as possible to MGC3X30. The 10 kΩ resistor and the MGC3X30 input capacitance are building a low-pass filter with a corner frequency of 3 MHz. An Additional ferrite bead is recommended to suppress the coupling of RF noise to the Tx channel (e.g., 600 Ω at 100 MHz).

An additional ferrite bead is recommended to suppress the coupling of RF noise to the Tx channel (e.g., 600 Ω at 100 MHz).

FIGURE 6-2: REFERENCE SCHEMATIC FOR MGC3X30

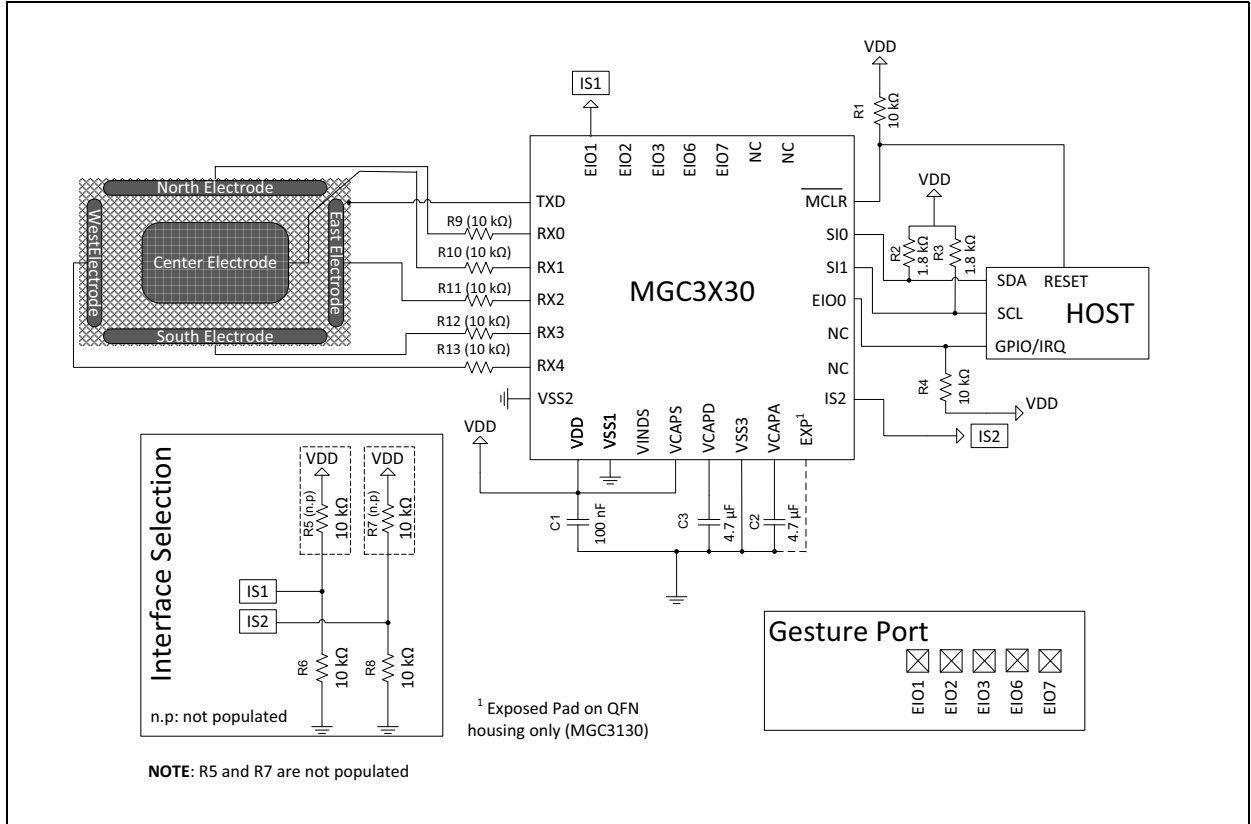

MGC3030/3130

TABLE 6-1: BILL OF MATERIALS

Label	Qty	Value	Description
R1, R4, R5, R6, R7, R8	3	10 k Ω	Res Thick Film 10 k Ω 1%
C1	1	100 nF	Capacitor – Ceramic, 0.1 μ F, 10%, 6.3V
C2	1	4.7 μ F	Capacitor – Ceramic, 4.7 μ F, 10%, 6.3V
C3	1	4.7 μ F	Capacitor – Ceramic, 4.7 μ F, 10%, 6.3V
R2, R3	2	1.8 k Ω	Res Thick Film 1.8 k Ω 1%
R9, R10, R11, R12, R13	5	10 k Ω	Res Thick Film 10 k Ω 1%

6.5 Layout Recommendation

This section will provide a brief description of layout hints for a proper system design.

The PCB layout requirements for MGC3X30 follow the general rules for a mixed signal design. In addition, there are certain requirements to be considered for the sensor signals and electrode feeding lines.

The chip should be placed as close as possible to the electrodes to keep their feeding lines as short as possible. Furthermore, it is recommended to keep MGC3X30 away from electrical and thermal sources within the system.

Analog and digital signals should be separated from each other during PCB layout in order to minimize crosstalk.

The individual electrode feeding lines should be kept as far as possible apart from each other.

VDD lines should be routed as wide as possible.

MGC3X30 requires a proper ground connection on all VSS pins, including the exposed pad (pin 29).

7.0 DEVELOPMENT SUPPORT

Microchip provides software and hardware development tools for the MGC3X30:

- Software:
 - Aurea Software Package
 - MGC3030/3130 Software Development Kit
 - MGC3030/3130 Host Reference Code
- Schematics:
 - GestIC[®] Hardware References
- Evaluation and Development Kits:
 - MGC3130 Hillstar Development Kit (DM160218)
 - MGC3030 Woodstar Development Kit (DM160226)

7.1 Aurea Software Package

The Aurea evaluation software demonstrates Microchip's GestIC technology and its features and applications. Aurea provides visualization of the MGC3X30 generated data and access to GestIC Library controls and configuration parameters.

That contains the following:

- Visualization of hand position and user gestures
- Visualization of sensor data
- Real-time control of sensor features
- MGC3X30 GestIC Library update
- Analog front end parameterization
- Colibri parameterization
- Electrode capacitance measurement
- Logging of sensor values and storage in a log file

7.2 MGC3030/3130 Software Development Kit

Microchip provides a standard C reference code with a Software Development Kit. The code will support developers to integrate the MGC3X30 solution into the target application.

7.3 MGC3030/3130 PIC18 Host Reference Code

Microchip provides a reference code for PIC18F14K50, including GestIC Library I²C™ code and basic message decoding.

7.4 GestIC Hardware References

The GestIC Hardware References package contains the PCB Layouts (Gerber files) for the MGC development kits (Hillstar and Woodstar) and a collection of electrode reference designs fitting both kits. In addition, the package includes designs, parameter files and host code of various demonstrators which represent complete systems for embedded or PC-based applications. New designs will be added to the package once they are available. The GestIC Hardware Reference package can be downloaded from Microchip's website via www.microchip.com/GestICResources.

7.5 Evaluation and Demonstration Kits

A variety of demonstration, development and evaluation boards allow quick application development on fully-functional systems. The demonstration and development boards can be used in teaching environments, for prototyping custom circuits and for learning about various GestIC MGC3130 applications.

The first development board is the Hillstar Development Kit. It is designed to support an easy integration of Microchip's MGC3130 3D Tracking and Gesture Controller into the customer's applications. It provides MGC3130 system hardware modules and a set of electrode reference designs which can be used by customers to develop their own GestIC system. Aurea Visualization and Control Software provides full support of the Hillstar Development Kit and an easy parameterization of the customer's applications.

The Woodstar Development Kit is a development platform to support an easy integration of Microchip's MGC3030. It provides MGC3030 system hardware modules and a set of electrode reference designs which can be used by customers to develop their own GestIC system. Aurea Visualization and Control Software provides full support of the Woodstar Development Kit and an easy parameterization of the customer's applications.

Woodstar and Hillstar offer the same interface (hardware as well as software). The electrodes, the I²C-to-USB bridge as well as Aurea software can both be used for Hillstar and Woodstar development kit.

For the complete list of demonstration, development and evaluation kits, please refer to the Microchip website (<http://www.microchip.com/GestICGettingStarted>).

7.6 GestIC Library Update

The MGC3X30 devices are manufactured with a built-in Library Loader (bootloader) only. There will be no GestIC library on it. The library loader contains the I²C interface and basic device programming operations so that a GestIC library can be uploaded to the MGC3X30 Flash memory.

The latest GestIC library can be found in the package 'Aurea Software Package' which can be downloaded from the GestIC homepage.

There are several ways to upload the library to the MGC3X30:

1. Upload via Aurea Visualization and Control Software: The Aurea Graphical User Interface (GUI) can be used to perform the update. For this option, USB connectivity to a PC with Aurea Graphical User Interface (GUI) will be needed (e.g., using I²C™-to-USB bridge of Hillstar Development Kit or Woodstar Development Kit). Please refer to "Aurea Graphical User Interface" (DS40001681), MGC3130 Hillstar Development Kit User's Guide (DS40001721) and MGC3030 Woodstar Development Kit User's Guide (DS40001777) for additional information.
2. Upload via embedded host controller: this option will require an embedded host controller which performs the upload using the GestIC I²C commands. The GestIC library is hereby stored in the host's memory. Please refer to "MGC3030/3130 GestIC Library Interface Description" (DS40001718) for more details.
3. Microchip Programming Center Pre-programmed MGC3X30 parts can be ordered through Microchip Programming Center. Please go to www.microchipdirect.com/programming/ for further information.
4. Quick Time Programming (QTP): for larger quantities of pre-programmed parts with unique part number, please see your local Microchip sales office.

8.0 ELECTRICAL SPECIFICATIONS

8.1 Absolute Maximum Ratings^(†)

Ambient temperature under bias	-20°C to +85°C
Storage temperature	-55°C to +125°C
Voltage on pins with respect to Vss	
on VDD pin	-0.3V to +3.465V
on all other pins	-0.3V to (VDD + 0.3V)

† **NOTICE:** Stresses above those listed under “Absolute Maximum Ratings” may cause permanent damage to the device. This is a stress rating only and functional operation of the device at those or any other conditions above those indicated in the operation listings of this specification is not implied. Exposure to maximum rating conditions for extended periods may affect device reliability.

† **NOTICE:** This device is sensitive to ESD damage and must be handled appropriately. Failure to properly handle and protect the device in an application may cause partial to complete failure of the device.

† **NOTICE:** -20°C temperature operation is characterized but not tested.

ADVANCE INFORMATION

MGC3030/3130

9.0 PACKAGING INFORMATION

9.1 Package Marking Information

28-Lead QFN (5x5x0.9 mm)

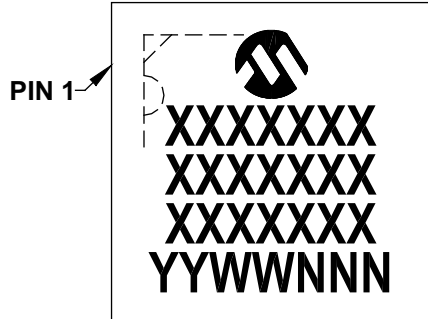

Example

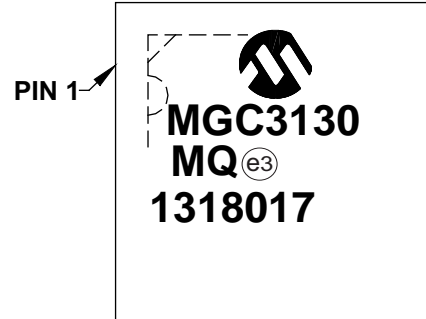

28-Lead SSOP (5.30 mm)

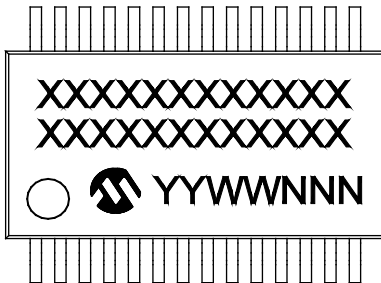

Example

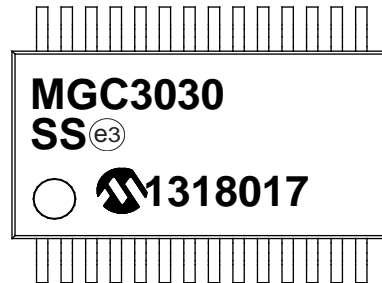

Legend:	XX...X	Customer-specific information
	Y	Year code (last digit of calendar year)
	YY	Year code (last 2 digits of calendar year)
	WW	Week code (week of January 1 is week '01')
	NNN	Alphanumeric traceability code
	(e3)	Pb-free JEDEC® designator for Matte Tin (Sn)
	*	This package is Pb-free. The Pb-free JEDEC designator (e3) can be found on the outer packaging for this package.

Note: In the event the full Microchip part number cannot be marked on one line, it will be carried over to the next line, thus limiting the number of available characters for customer-specific information.

9.2 Package Details

The following sections give the technical details of the packages.

28-Lead Plastic Quad Flat, No Lead Package (MQ) – 5x5x0.9 mm Body [QFN or VQFN]

Note: For the most current package drawings, please see the Microchip Packaging Specification located at <http://www.microchip.com/packaging>

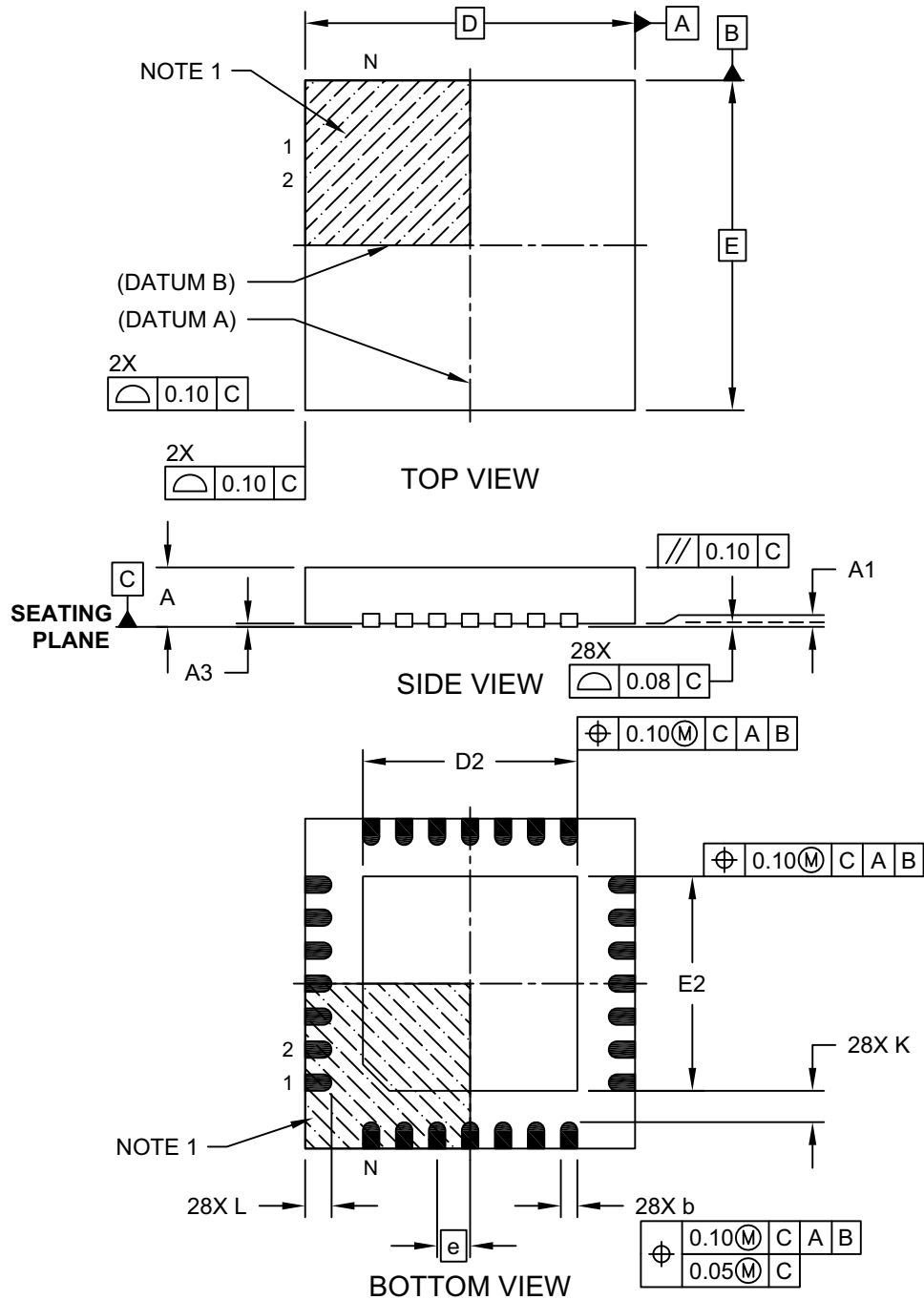

Microchip Technology Drawing C04-140C Sheet 1 of 2

MGC3030/3130

28-Lead Plastic Quad Flat, No Lead Package (MQ) – 5x5x0.9 mm Body [QFN or VQFN]

Note: For the most current package drawings, please see the Microchip Packaging Specification located at <http://www.microchip.com/packaging>

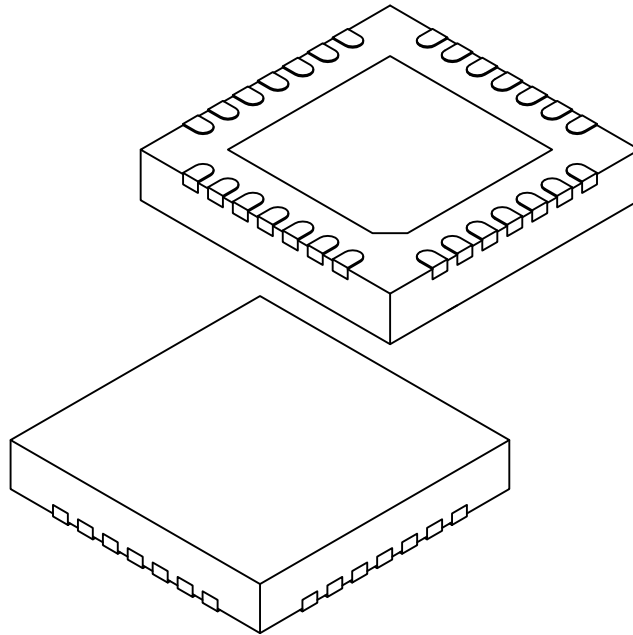

Dimension Limits	Units	MILLIMETERS		
		MIN	NOM	MAX
Number of Pins	N	28		
Pitch	e	0.50 BSC		
Overall Height	A	0.80	0.90	1.00
Standoff	A1	0.00	0.02	0.05
Contact Thickness	A3	0.20 REF		
Overall Width	E	5.00 BSC		
Exposed Pad Width	E2	3.15	3.25	3.35
Overall Length	D	5.00 BSC		
Exposed Pad Length	D2	3.15	3.25	3.35
Contact Width	b	0.18	0.25	0.30
Contact Length	L	0.35	0.40	0.45
Contact-to-Exposed Pad	K	0.20	-	-

Notes:

1. Pin 1 visual index feature may vary, but must be located within the hatched area.
2. Package is saw singulated.
3. Dimensioning and tolerancing per ASME Y14.5M.
BSC: Basic Dimension. Theoretically exact value shown without tolerances.
REF: Reference Dimension, usually without tolerance, for information purposes only.

Microchip Technology Drawing C04-140C Sheet 2 of 2

28-Lead Plastic Quad Flat, No Lead Package (MQ) – 5x5 mm Body [QFN] Land Pattern With 0.55 mm Contact Length

Note: For the most current package drawings, please see the Microchip Packaging Specification located at <http://www.microchip.com/packaging>

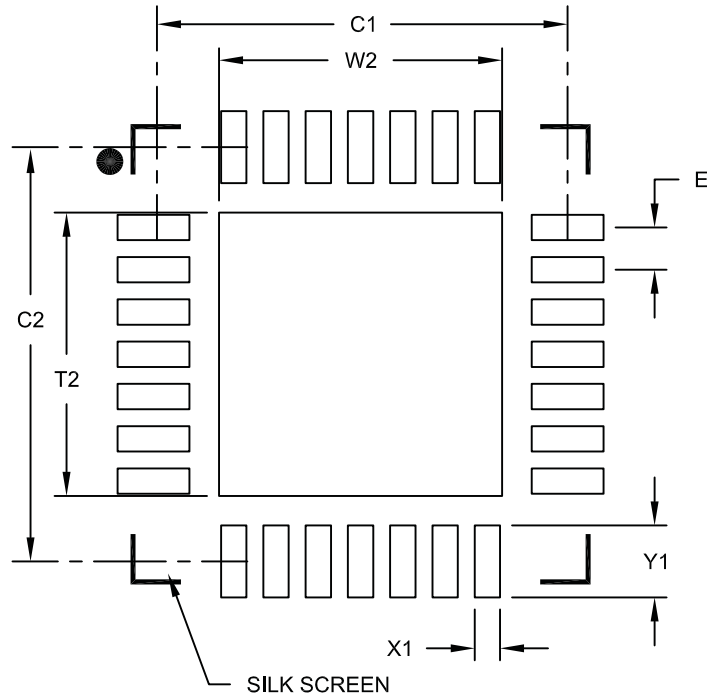

RECOMMENDED LAND PATTERN

Dimension Limits	Units	MILLIMETERS		
		MIN	NOM	MAX
Contact Pitch	E	0.50 BSC		
Optional Center Pad Width	W2			3.35
Optional Center Pad Length	T2			3.35
Contact Pad Spacing	C1		4.90	
Contact Pad Spacing	C2		4.90	
Contact Pad Width (X28)	X1			0.30
Contact Pad Length (X28)	Y1			0.85

Notes:

1. Dimensioning and tolerancing per ASME Y14.5M
BSC: Basic Dimension. Theoretically exact value shown without tolerances.

Microchip Technology Drawing C04-2140A

MGC3030/3130

28-Lead Plastic Shrink Small Outline (SS) – 5.30 mm Body [SSOP]

Note: For the most current package drawings, please see the Microchip Packaging Specification located at <http://www.microchip.com/packaging>

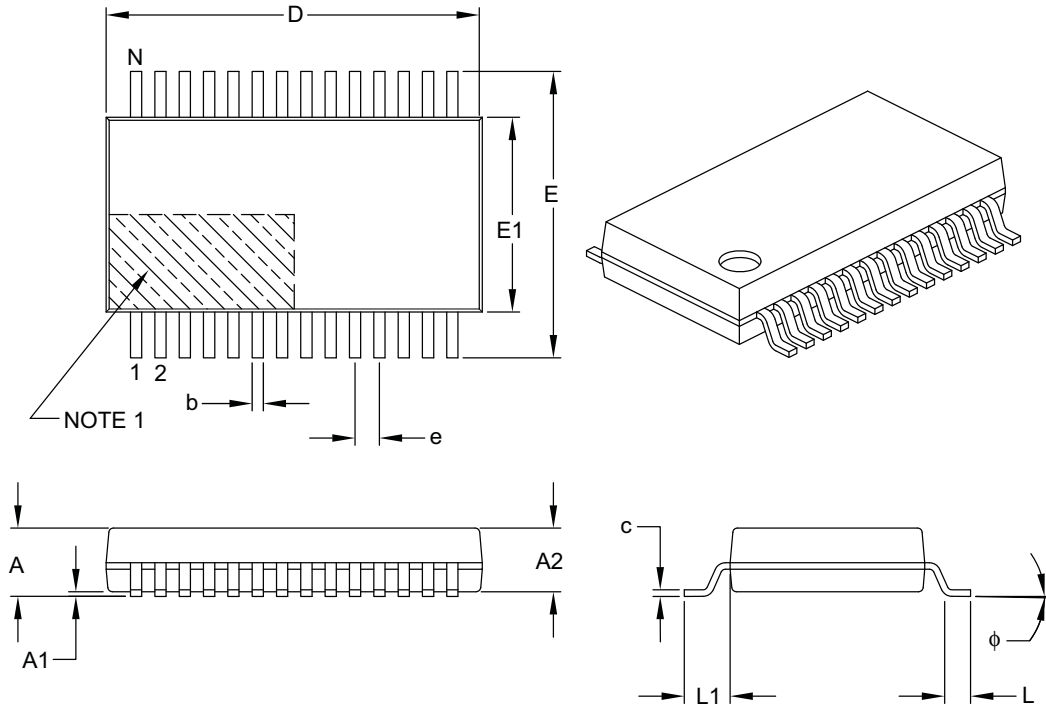

Dimension Limits	Units	MILLIMETERS		
		MIN	NOM	MAX
Number of Pins	N	28		
Pitch	e	0.65 BSC		
Overall Height	A	–	–	2.00
Molded Package Thickness	A2	1.65	1.75	1.85
Standoff	A1	0.05	–	–
Overall Width	E	7.40	7.80	8.20
Molded Package Width	E1	5.00	5.30	5.60
Overall Length	D	9.90	10.20	10.50
Foot Length	L	0.55	0.75	0.95
Footprint	L1	1.25 REF		
Lead Thickness	c	0.09	–	0.25
Foot Angle	ϕ	0°	4°	8°
Lead Width	b	0.22	–	0.38

Notes:

- Pin 1 visual index feature may vary, but must be located within the hatched area.
- Dimensions D and E1 do not include mold flash or protrusions. Mold flash or protrusions shall not exceed 0.20 mm per side.
- Dimensioning and tolerancing per ASME Y14.5M.

BSC: Basic Dimension. Theoretically exact value shown without tolerances.

REF: Reference Dimension, usually without tolerance, for information purposes only.

Microchip Technology Drawing C04-073B

28-Lead Plastic Shrink Small Outline (SS) - 5.30 mm Body [SSOP]

Note: For the most current package drawings, please see the Microchip Packaging Specification located at <http://www.microchip.com/packaging>

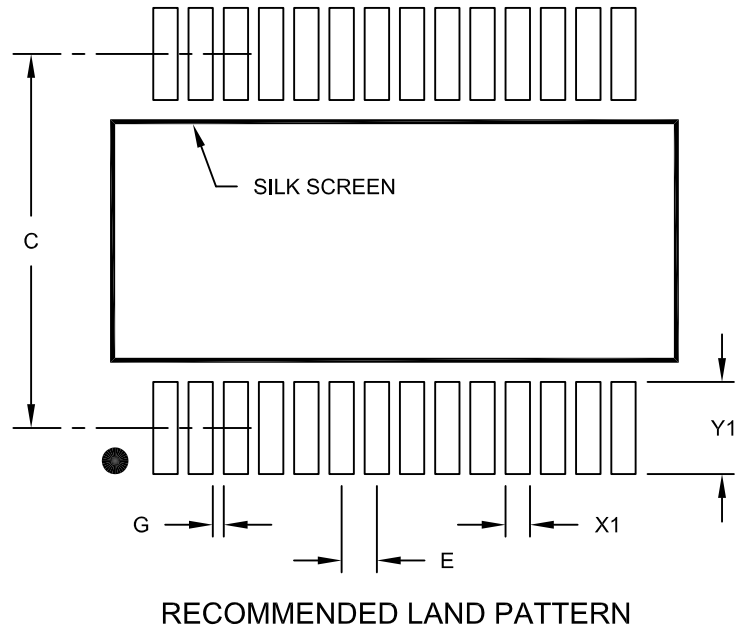

Dimension Limits	Units	MILLIMETERS		
		MIN	NOM	MAX
Contact Pitch	E	0.65 BSC		
Contact Pad Spacing	C		7.20	
Contact Pad Width (X28)	X1			0.45
Contact Pad Length (X28)	Y1			1.75
Distance Between Pads	G	0.20		

Notes:

1. Dimensioning and tolerancing per ASME Y14.5M

BSC: Basic Dimension. Theoretically exact value shown without tolerances.

Microchip Technology Drawing No. C04-2073A

APPENDIX A: DATA SHEET REVISION HISTORY

Revision A (11/2012)

Initial release of this data sheet.

Revision B (08/2013)

Updated the Power Features section; Updated Table 1; Updated section 2, Feature Description; Updated section 4.2.2; Updated Figures 4-4, 4-5 and 4-6; Updated Equation 4-1, Table 4-1; Updated Figures 4-9, 5-1 and 5-2; Updated section 6, Interface Description, Updated Figures 7-1 and 7-2; Added section 7-3, Irradiated High-Frequency Noise; Updated Tables 7-1 and 7-2; Updated section 8, Development Support; Updated the Packaging Information section; Other minor corrections.

Revision C (11/2013)

Updated Figure 1 and Table 1; Updated Section 2, Feature Description; Updated Section 4, Functional Description; Updated Section 6, Interface Description; Updated Figure 7-1 and 7-2; Updated Section 8, Development Support; Other minor corrections.

Revision D (1/2015)

Updated Packaging Marking Section; Updated 6.6.1, 5.1, 4.5, 8.5, 8.6, 4.2 Sections; Updated Figures 2-2, 4-9, 4-10, 6-1, 6-2, 7-1; Other minor corrections.

Revision E (7/2017)

Revised Table 3: Pin Summary.

THE MICROCHIP WEBSITE

Microchip provides online support via our website at www.microchip.com. This website is used as a means to make files and information easily available to customers. Accessible by using your favorite Internet browser, the website contains the following information:

- **Product Support** – Data sheets and errata, application notes and sample programs, design resources, user's guides and hardware support documents, latest software releases and archived software
- **General Technical Support** – Frequently Asked Questions (FAQ), technical support requests, online discussion groups, Microchip consultant program member listing
- **Business of Microchip** – Product selector and ordering guides, latest Microchip press releases, listing of seminars and events, listings of Microchip sales offices, distributors and factory representatives

CUSTOMER CHANGE NOTIFICATION SERVICE

Microchip's customer notification service helps keep customers current on Microchip products. Subscribers will receive e-mail notification whenever there are changes, updates, revisions or errata related to a specified product family or development tool of interest.

To register, access the Microchip website at www.microchip.com. Under "Support", click on "Customer Change Notification" and follow the registration instructions.

CUSTOMER SUPPORT

Users of Microchip products can receive assistance through several channels:

- Distributor or Representative
- Local Sales Office
- Field Application Engineer (FAE)
- Technical Support

Customers should contact their distributor, representative or Field Application Engineer (FAE) for support. Local sales offices are also available to help customers. A listing of sales offices and locations is included in the back of this document.

Technical support is available through the website at: <http://www.microchip.com/support>

MGC3030/3130

PRODUCT IDENTIFICATION SYSTEM

To order or obtain information, e.g., on pricing or delivery, refer to the factory or the listed sales office.

<u>PART NO.</u>	<u>[X]⁽¹⁾</u>	-	<u>X</u>	<u>/XX</u>	<u>XXX</u>
Device	Tape and Reel Option		Temperature Range	Package	Pattern
Device:	MGC3030, MGC3130				
Tape and Reel Option:	Blank = Standard packaging (tube or tray) T = Tape and Reel ⁽¹⁾				
Temperature Range:	I = -40°C to +85°C (Industrial)				
Package:⁽²⁾	MQ = QFN SS = SSOP				
Pattern:	QTP, SQTP, Code or Special Requirements (blank otherwise)				

Examples:

a) MGC3130 - I/MQ
Industrial temperature,
QFN package

Note 1: Tape and Reel identifier only appears in the catalog part number description. This identifier is used for ordering purposes and is not printed on the device package. Check with your Microchip Sales Office for package availability with the Tape and Reel option.

2: For other small form-factor package availability and marking information, please visit www.microchip.com/packaging or contact your local sales office.

Note the following details of the code protection feature on Microchip devices:

- Microchip products meet the specification contained in their particular Microchip Data Sheet.
- Microchip believes that its family of products is one of the most secure families of its kind on the market today, when used in the intended manner and under normal conditions.
- There are dishonest and possibly illegal methods used to breach the code protection feature. All of these methods, to our knowledge, require using the Microchip products in a manner outside the operating specifications contained in Microchip's Data Sheets. Most likely, the person doing so is engaged in theft of intellectual property.
- Microchip is willing to work with the customer who is concerned about the integrity of their code.
- Neither Microchip nor any other semiconductor manufacturer can guarantee the security of their code. Code protection does not mean that we are guaranteeing the product as “unbreakable.”

Code protection is constantly evolving. We at Microchip are committed to continuously improving the code protection features of our products. Attempts to break Microchip's code protection feature may be a violation of the Digital Millennium Copyright Act. If such acts allow unauthorized access to your software or other copyrighted work, you may have a right to sue for relief under that Act.

Information contained in this publication regarding device applications and the like is provided only for your convenience and may be superseded by updates. It is your responsibility to ensure that your application meets with your specifications. MICROCHIP MAKES NO REPRESENTATIONS OR WARRANTIES OF ANY KIND WHETHER EXPRESS OR IMPLIED, WRITTEN OR ORAL, STATUTORY OR OTHERWISE, RELATED TO THE INFORMATION, INCLUDING BUT NOT LIMITED TO ITS CONDITION, QUALITY, PERFORMANCE, MERCHANTABILITY OR FITNESS FOR PURPOSE. Microchip disclaims all liability arising from this information and its use. Use of Microchip devices in life support and/or safety applications is entirely at the buyer's risk, and the buyer agrees to defend, indemnify and hold harmless Microchip from any and all damages, claims, suits, or expenses resulting from such use. No licenses are conveyed, implicitly or otherwise, under any Microchip intellectual property rights unless otherwise stated.

Microchip received ISO/TS-16949:2009 certification for its worldwide headquarters, design and wafer fabrication facilities in Chandler and Tempe, Arizona; Gresham, Oregon and design centers in California and India. The Company's quality system processes and procedures are for its PIC[®] MCUs and dsPIC[®] DSCs, KEELoQ[®] code hopping devices, Serial EEPROMs, microperipherals, nonvolatile memory and analog products. In addition, Microchip's quality system for the design and manufacture of development systems is ISO 9001:2000 certified.

**QUALITY MANAGEMENT SYSTEM
CERTIFIED BY DNV
= ISO/TS 16949 =**

Trademarks

The Microchip name and logo, the Microchip logo, AnyRate, AVR, AVR logo, AVR Freaks, BeaconThings, BitCloud, chipKIT, chipKIT logo, CryptoMemory, CryptoRF, dsPIC, FlashFlex, flexPWR, Helder, JukeBlox, KEELoQ, KEELoQ logo, Kleer, LANCheck, LINK MD, maXStylus, maXTouch, MedialB, megaAVR, MOST, MOST logo, MPLAB, OptoLyzer, PIC, picoPower, PICSTART, PIC32 logo, Prochip Designer, QTouch, RightTouch, SAM-BA, SpyNIC, SST, SST Logo, SuperFlash, tinyAVR, UNI/O, and XMEGA are registered trademarks of Microchip Technology Incorporated in the U.S.A. and other countries.

ClockWorks, The Embedded Control Solutions Company, EtherSynch, Hyper Speed Control, HyperLight Load, IntelliMOS, mTouch, Precision Edge, and Quiet-Wire are registered trademarks of Microchip Technology Incorporated in the U.S.A.

Adjacent Key Suppression, AKS, Analog-for-the-Digital Age, Any Capacitor, AnyIn, AnyOut, BodyCom, CodeGuard, CryptoAuthentication, CryptoCompanion, CryptoController, dsPICDEM, dsPICDEM.net, Dynamic Average Matching, DAM, ECAN, EtherGREEN, In-Circuit Serial Programming, ICSP, Inter-Chip Connectivity, JitterBlocker, KleerNet, KleerNet logo, Mindi, MiWi, motorBench, MPASM, MPF, MPLAB Certified logo, MPLIB, MPLINK, MultiTRAK, NetDetach, Omniscient Code Generation, PICDEM, PICDEM.net, PICKit, PICtail, PureSilicon, QMatrix, RightTouch logo, REAL ICE, Ripple Blocker, SAM-ICE, Serial Quad I/O, SMART-I.S., SQI, SuperSwitcher, SuperSwitcher II, Total Endurance, TSHARC, USBCheck, VariSense, ViewSpan, WiperLock, Wireless DNA, and ZENA are trademarks of Microchip Technology Incorporated in the U.S.A. and other countries.

SQTP is a service mark of Microchip Technology Incorporated in the U.S.A.

Silicon Storage Technology is a registered trademark of Microchip Technology Inc. in other countries.

GestIC is a registered trademark of Microchip Technology Germany II GmbH & Co. KG, a subsidiary of Microchip Technology Inc., in other countries.

All other trademarks mentioned herein are property of their respective companies.

© 2012-2017, Microchip Technology Incorporated, All Rights Reserved.

ISBN: 978-1-5224-1910-5



MICROCHIP

Worldwide Sales and Service

AMERICAS

Corporate Office
2355 West Chandler Blvd.
Chandler, AZ 85224-6199
Tel: 480-792-7200
Fax: 480-792-7277
Technical Support:
<http://www.microchip.com/support>
Web Address:
www.microchip.com

Atlanta
Duluth, GA
Tel: 678-957-9614
Fax: 678-957-1455

Austin, TX
Tel: 512-257-3370

Boston
Westborough, MA
Tel: 774-760-0087
Fax: 774-760-0088

Chicago
Itasca, IL
Tel: 630-285-0071
Fax: 630-285-0075

Dallas
Addison, TX
Tel: 972-818-7423
Fax: 972-818-2924

Detroit
Novi, MI
Tel: 248-848-4000

Houston, TX
Tel: 281-894-5983

Indianapolis
Noblesville, IN
Tel: 317-773-8323
Fax: 317-773-5453
Tel: 317-536-2380

Los Angeles
Mission Viejo, CA
Tel: 949-462-9523
Fax: 949-462-9608
Tel: 951-273-7800

Raleigh, NC
Tel: 919-844-7510

New York, NY
Tel: 631-435-6000

San Jose, CA
Tel: 408-735-9110
Tel: 408-436-4270

Canada - Toronto
Tel: 905-695-1980
Fax: 905-695-2078

ASIA/PACIFIC

Asia Pacific Office
Suites 3707-14, 37th Floor
Tower 6, The Gateway
Harbour City, Kowloon

Hong Kong
Tel: 852-2943-5100
Fax: 852-2401-3431

Australia - Sydney
Tel: 61-2-9868-6733
Fax: 61-2-9868-6755

China - Beijing
Tel: 86-10-8569-7000
Fax: 86-10-8528-2104

China - Chengdu
Tel: 86-28-8665-5511
Fax: 86-28-8665-7889

China - Chongqing
Tel: 86-23-8980-9588
Fax: 86-23-8980-9500

China - Dongguan
Tel: 86-769-8702-9880

China - Guangzhou
Tel: 86-20-8755-8029

China - Hangzhou
Tel: 86-571-8792-8115
Fax: 86-571-8792-8116

China - Hong Kong SAR
Tel: 852-2943-5100
Fax: 852-2401-3431

China - Nanjing
Tel: 86-25-8473-2460
Fax: 86-25-8473-2470

China - Qingdao
Tel: 86-532-8502-7355
Fax: 86-532-8502-7205

China - Shanghai
Tel: 86-21-3326-8000
Fax: 86-21-3326-8021

China - Shenyang
Tel: 86-24-2334-2829
Fax: 86-24-2334-2393

China - Shenzhen
Tel: 86-755-8864-2200
Fax: 86-755-8203-1760

China - Wuhan
Tel: 86-27-5980-5300
Fax: 86-27-5980-5118

China - Xian
Tel: 86-29-8833-7252
Fax: 86-29-8833-7256

ASIA/PACIFIC

China - Xiamen
Tel: 86-592-2388138
Fax: 86-592-2388130

China - Zhuhai
Tel: 86-756-3210040
Fax: 86-756-3210049

India - Bangalore
Tel: 91-80-3090-4444
Fax: 91-80-3090-4123

India - New Delhi
Tel: 91-11-4160-8631
Fax: 91-11-4160-8632

India - Pune
Tel: 91-20-3019-1500

Japan - Osaka
Tel: 81-6-6152-7160
Fax: 81-6-6152-9310

Japan - Tokyo
Tel: 81-3-6880-3770
Fax: 81-3-6880-3771

Korea - Daegu
Tel: 82-53-744-4301
Fax: 82-53-744-4302

Korea - Seoul
Tel: 82-2-554-7200
Fax: 82-2-558-5932 or
82-2-558-5934

Malaysia - Kuala Lumpur
Tel: 60-3-6201-9857
Fax: 60-3-6201-9859

Malaysia - Penang
Tel: 60-4-227-8870
Fax: 60-4-227-4068

Philippines - Manila
Tel: 63-2-634-9065
Fax: 63-2-634-9069

Singapore
Tel: 65-6334-8870
Fax: 65-6334-8850

Taiwan - Hsin Chu
Tel: 886-3-5778-366
Fax: 886-3-5770-955

Taiwan - Kaohsiung
Tel: 886-7-213-7830

Taiwan - Taipei
Tel: 886-2-2508-8600
Fax: 886-2-2508-0102

Thailand - Bangkok
Tel: 66-2-694-1351
Fax: 66-2-694-1350

EUROPE

Austria - Wels
Tel: 43-7242-2244-39
Fax: 43-7242-2244-393

Denmark - Copenhagen
Tel: 45-4450-2828
Fax: 45-4485-2829

Finland - Espoo
Tel: 358-9-4520-820

France - Paris
Tel: 33-1-69-53-63-20
Fax: 33-1-69-30-90-79

France - Saint Cloud
Tel: 33-1-30-60-70-00

Germany - Garching
Tel: 49-8931-9700

Germany - Haan
Tel: 49-2129-3766400

Germany - Heilbronn
Tel: 49-7131-67-3636

Germany - Karlsruhe
Tel: 49-721-625370

Germany - Munich
Tel: 49-89-627-144-0
Fax: 49-89-627-144-44

Germany - Rosenheim
Tel: 49-8031-354-560

Israel - Ra'anana
Tel: 972-9-744-7705

Italy - Milan
Tel: 39-0331-742611
Fax: 39-0331-466781

Italy - Padova
Tel: 39-049-7625286

Netherlands - Drunen
Tel: 31-416-690399
Fax: 31-416-690340

Norway - Trondheim
Tel: 47-7289-7561

Poland - Warsaw
Tel: 48-22-3325737

Romania - Bucharest
Tel: 40-21-407-87-50

Spain - Madrid
Tel: 34-91-708-08-90
Fax: 34-91-708-08-91

Sweden - Gothenberg
Tel: 46-31-704-60-40

Sweden - Stockholm
Tel: 46-8-5090-4654

UK - Wokingham
Tel: 44-118-921-5800
Fax: 44-118-921-5820

X-ON Electronics

Largest Supplier of Electrical and Electronic Components

Click to view similar products for [Proximity Sensors](#) category:

Click to view products by [Microchip](#) manufacturer:

Other Similar products are found below :

[01.001.5653.1](#) [70.340.1028.0](#) [70.360.2428.0](#) [70.364.4828.0](#) [70.810.1053.0](#) [72.360.1628.0](#) [73.363.6428.0](#) [8027AL20NL2CPXX](#) [FYCC8E1-2](#)
[9221350022](#) [922AA2W-A9P-L](#) [PLS2](#) [GL-12F-C2.5X10\(LOT3\)](#) [972AB2XM-A3N-L](#) [972AB3XM-A3P-L](#) [PS3251](#) [980659-1](#) [QT-12](#) [E2E2-](#)
[X5M41-M4](#) [E2E-X14MD1-G](#) [E2E-X2D1-G](#) [E2EX2ME2N](#) [E2EX3D1SM1N](#) [E2E-X4MD1-G](#) [E2E-X5E1-5M-N](#) [E2E-X5Y2-N](#) [E2E-X7D1-](#)
[M1J-T-0.3M-N](#) [E2FMX1R5D12M](#) [E2K-F10MC1](#) [5M](#) [EH-302](#) [EI3010TBOP](#) [EI5515NPAP](#) [MS605AU](#) [EP175-32000](#) [BSA-08-25-08](#)
[IFRM04N35B1/L](#) [IFRM04P1513/S35L](#) [IFRM06P1703/S35L](#) [IFRM08P1501/S35L](#) [IFRM12N17G3/L](#) [IFRM12P17G3/L](#) [IFRM12P3502/L](#)
[IFRM12P37G1/S14L](#) [ILFK12E9189/I02](#) [ILFK12E9193/I02](#) [IMM2582C](#) [OISN-013](#) [25.161.3253.0](#) [25.332.0653.1](#) [25.352.0653.0](#)