



MIC22405YML EV

Evaluation Board

**4A Integrated Switch High-Efficiency
Synchronous Buck Regulator with
Frequency Programmable upto 4MHz**

General Description

The Micrel MIC22405 is a high-efficiency, 4A, integrated switch, synchronous buck (step-down) regulator. The MIC22405 achieves more than 95% efficiency and switches at 1MHz. The ultra-high speed control loop keeps the output voltage within regulation even under extreme transient load swings commonly found in FPGAs and low-voltage ASICs. The output voltage is pre-bias safe and is adjustable down to 0.7V.

The MIC22405 offers a full range of sequencing and tracking options. The Enable/Delay (EN/DLY) and Power Good (PG) inputs allow versatile turn-on and turn-off sequencing across multiple devices. The Ramp Control™ (RC) input allows start-up voltage tracking, either directly or ratio-metrically.

The MIC22405 is available in a 20-pin 3mm x 4mm MLF® with a junction operating range from -40°C to +125°C.

Data sheets and support documentation are found on the Micrel web site: www.micrel.com.

Requirements

The MIC22405YML EV requires a power supply of 2.9V to 5.5V, and a test load. Ensure that the power supply can provide the wattage required for the chosen test load. The load can be active (electronic load) or passive (resistor). Additionally, monitor the Power Good output (PG) with a multimeter or an oscilloscope if desired.

Precautions

There is no reverse input protection on this board. While connecting supplies and signals ensure that correct polarities are observed.

Getting Started

1. V_{IN} Supplies

Connect the V_{IN} supply (2.9V to 5.5V) across the VIN and GND terminals. Monitor V_{IN} at the VIN and GND terminals with a voltmeter.

2. Enable/SHDN Inputs

The enable input EN is internally pulled up with a 1 μ A current source. When external on/off control is desired install Q1 and R5, and connect a logic level control signal to the SHDN input. When SHDN is high the output is off, and when SHDN is low the output is on.

3. Monitor Outputs

Monitor the output V_{OUT} with a scope or DVM connected across the VOUT and GND terminals.

4. Output Load

Connect a load across the VOUT and GND terminals. Use an active or passive load.

5. Turn On the Power

Turn on the power supply and verify that $V_{OUT} = 1.8V$.

Ordering Information

Part Number	Description
MIC22405YML EV	Evaluation Board for the MIC22405YML

Ramp Control is a trademark of Micrel, Inc.

Micrel Inc. • 2180 Fortune Drive • San Jose, CA 95131 • USA • tel +1 (408) 944-0800 • fax + 1 (408) 474-1000 • <http://www.micrel.com>

July 2011

M9999-071911-B

Evaluation Board Features

Enable/Delay (EN/DLY)

Enable/Delay allows delayed turn on of the MIC22405. Install a capacitor in location C4 to increase the start-up delay of the MIC22405.

Shutdown Input (SHDN)

SHDN allows enable/disable of the MIC22405 with an external logic signal. To activate the shutdown feature install components into the locations labeled Q1 and R5 (component recommendations are listed in the Bill of Materials later in this document). With the components installed, force SHDN high to disable the MIC22405, and low to allow the MIC22405 to operate normally.

Ramp Control (RC)

Ramp control allows slowing the slew rate of the MIC22405 output. Increase the value of capacitor C6 to reduce the slew rate.

Power Good Output (PG)

Open drain output PG pulls low when the output voltage of the MIC22405 is out of specification. PG is pulled up to V_{IN} by a 47.5k Ω resistor.

Switch Voltage (V_{SW})

Test point V_{SW} is provided to monitor the internal switching node. V_{SW} is isolated from the switch node by 49.9 Ω resistor R7.

Typical Characteristics

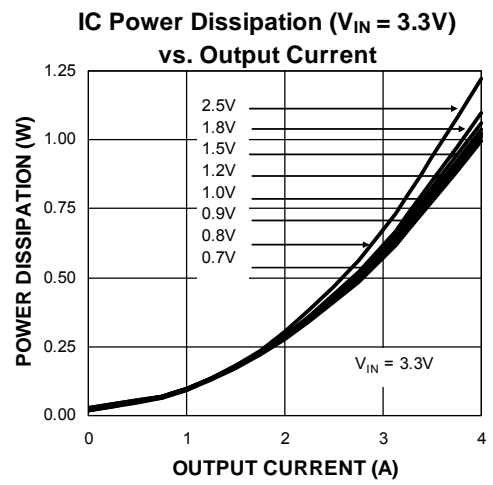
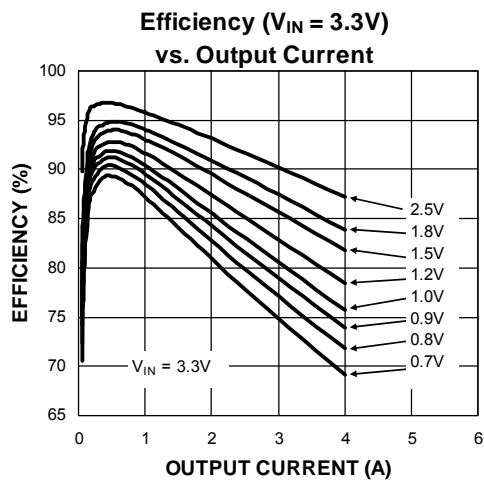

Functional Characteristics

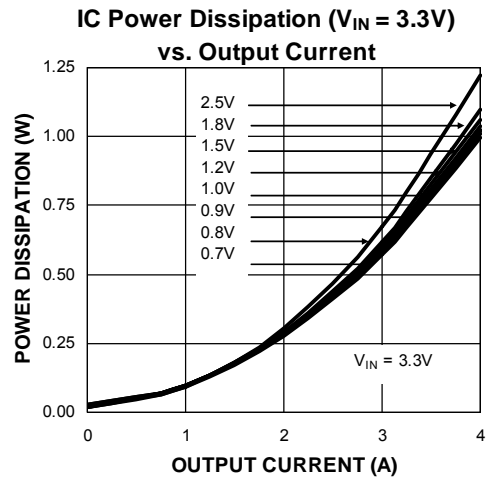
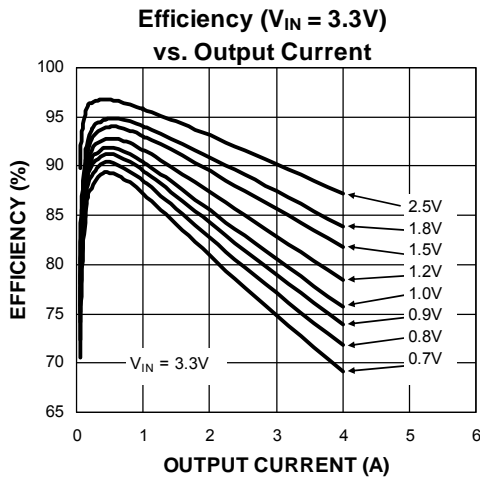
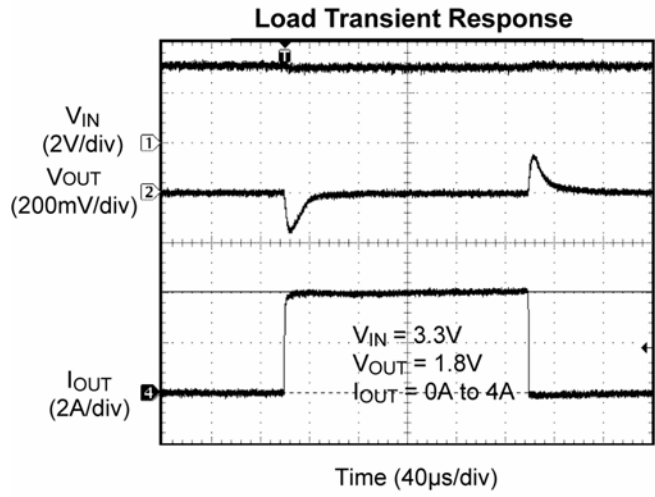
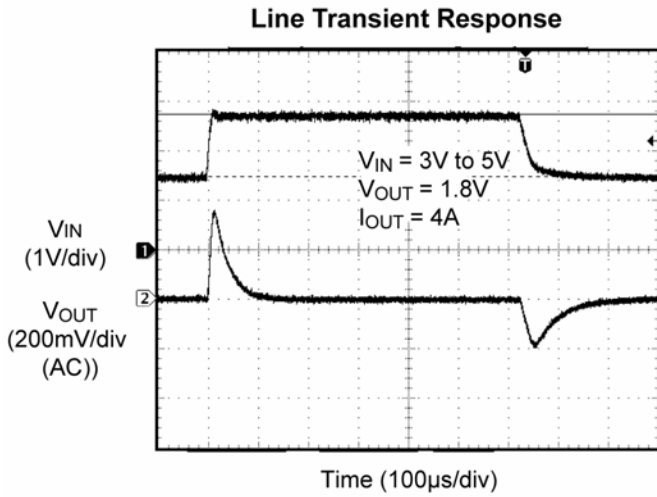
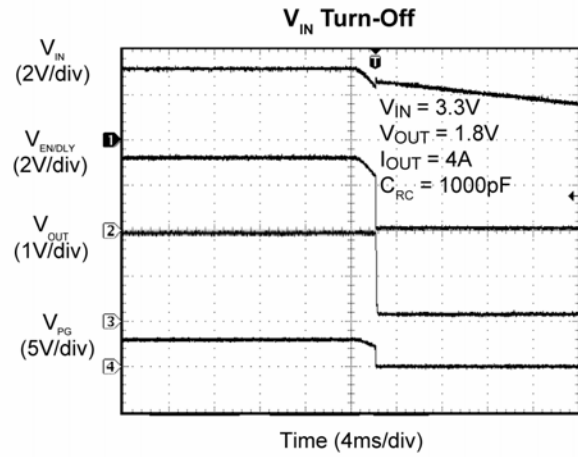
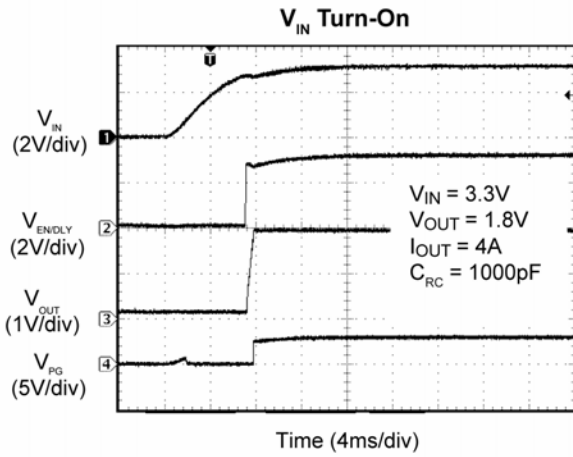

Evaluation Board Schematic

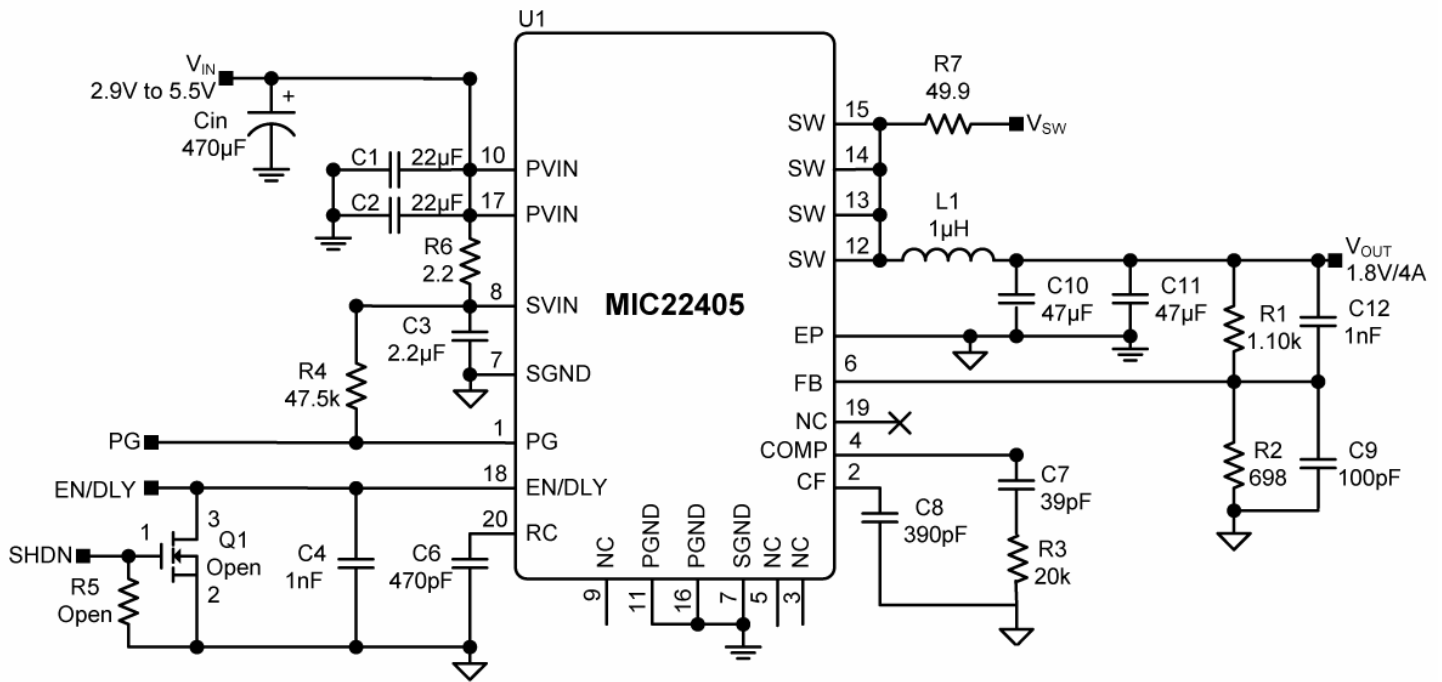

Bill of Materials

Item	Part Number	Manufacturer	Description	Qty.
C1, C2	08056D226MAT	AVX ⁽¹⁾	Capacitor, 22µF, 6.3V, X5R, Size 0805	2
	C2012X5R0J226M	TDK ⁽²⁾		
	GRM21BR60J226ME39L	Murata ⁽³⁾		
C3	06036D225MAT2A	AVX ⁽²⁾	2.2µF/6.3V, Ceramic Capacitor, X5R, Size 0603	1
	GRM188R60J225M	Murata ⁽³⁾		
	C1608X5R0J225M	TDK ⁽¹⁾		
C4, C12	GRM188R71H102KA01D	Murata ⁽³⁾	Capacitor, 1nF, 50V, X7R, Size 0603	2
	C1608C0G1H102J	TDK ⁽²⁾		
	06035C102KAT2A	AVX ⁽¹⁾		
C6	GRM188R71H471KA01D	Murata ⁽³⁾	Capacitor, 470pF, 50V, X7R, Size 0603	1
	C1608X7RH471K	TDK ⁽²⁾		
	06035C471KAT2A	AVX ⁽¹⁾		
C7	GRM188R71H390JA01	Murata ⁽³⁾	Capacitor, 39pF, 50V, Size 0603	1
	C1608COG1H390J	TDK ⁽²⁾		
	06035A390JAT2A	AVX ⁽¹⁾		
C8	GRM188R71H391JA01	Murata ⁽³⁾	Capacitor, 390pF, 50V, Size 0603	1
	1608COG1H391J	TDK ⁽²⁾		
	06035A391JAT2A	AVX ⁽¹⁾		

Bill of Materials (Continued)

Item	Part Number	Manufacturer	Description	Qty.
C9	GRM188R71H101JA01	Murata ⁽³⁾	Capacitor, 100pF, 50V, Size 0603	1
	C1608COG1H101J	TDK ⁽²⁾		
	06035A101JT2A	AVX ⁽¹⁾		
C10, C11	GRM31CR60J476ME19	Murata ⁽³⁾	Capacitor, 47µF, 6.3V, X5R, Size 1206	2
	C3216X5R0J476M	TDK ⁽²⁾		
	12066D476MAT2A	AVX ⁽¹⁾		
Cin	B41125A3477M	Epcos	470µF, 10V, Electrolytic, 8x10-case	
L1	FP3-1R0-R(7.2x6.7x3mm)	Cooper ⁽⁵⁾	Inductor, 1µH, 6.26A	1
	CDRH8D28NP-1R0NC (8x6x3mm)	Sumida ⁽⁶⁾	Inductor, 1µH, 8A	1
	SPM6530T-1R0M120 (7x6.5x3mm)	TDK ⁽²⁾	Inductor, 1µH, 12A	1
R1	CRCW06031101FKEYE3	Vishay ⁽⁴⁾	Resistor, 1.1k, 1%, Size 0603	1
R2	CRCW06036980FKEYE3	Vishay ⁽⁴⁾	Resistor, 698Ω, 1%, Size 0603	1
R3	CRCW06032002FKEYE3	Vishay ⁽⁴⁾	Resistor, 20k, 1%, Size 0603	1
R4	CRCW06034752FKEYE3	Vishay ⁽⁴⁾	Resistor, 47.5k, 1%, Size 0603	1
R5	(Open) CRCW06031003FKEYE3	Vishay ⁽⁴⁾	Resistor, 100k, 1%, Size 0603	1
R6	CRCW06032R20FKEA	Vishay ⁽⁴⁾	Resistor, 2.2Ω, 1%, Size 0603	1
R7	CRCW060349R9FKEA	Vishay ⁽⁴⁾	Resistor, 49.9Ω, 1%, Size 0603	1
Q1	2N7002E	Vishay ⁽⁴⁾	Open	1
U1	MIC22405YML	Micrel⁽⁷⁾	Integrated 4A Synchronous Buck Regulator	1

Notes:

1. AVX: www.avx.com
2. TDK: www.tdk.com
3. Murata: www.murata.com
4. Vishay: www.vishay.com
5. Cooper Bussmann: www.cooperet.com
6. Sumida: www.sumida.com
7. **Micrel, Inc.:** www.micrel.com

Evaluation Board PCB Layout

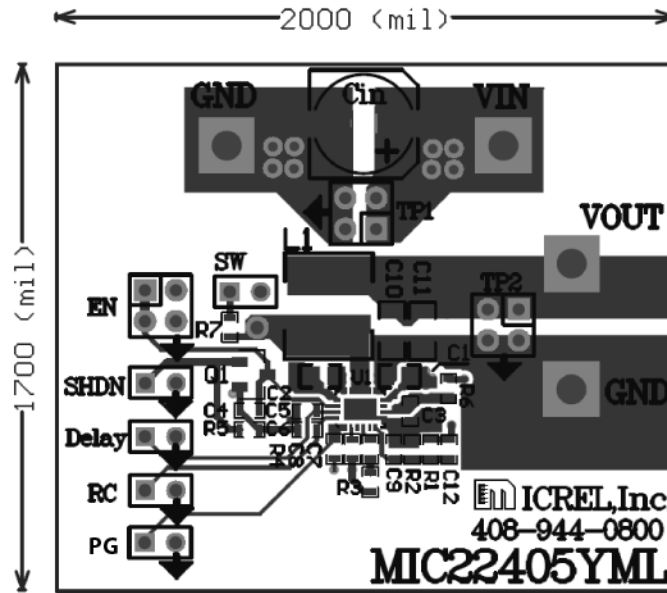

MIC22405 Evaluation Board Top Layer

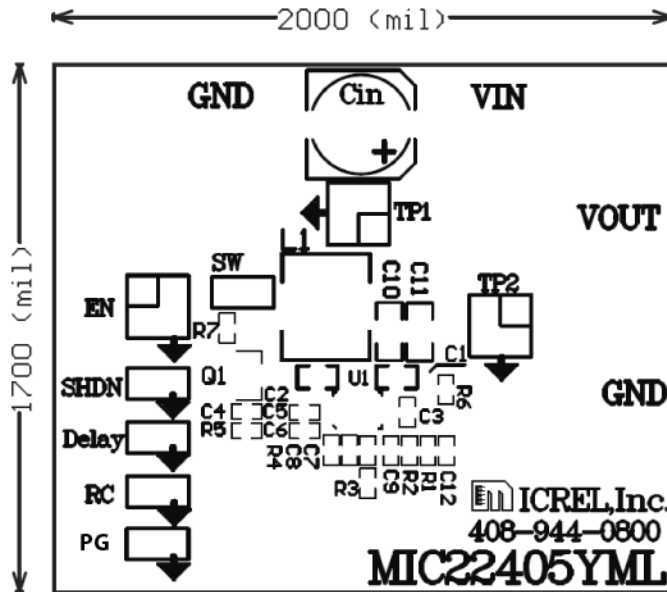

MIC22405 Evaluation Board Top Silk

Evaluation Board PCB Layout (Continued)

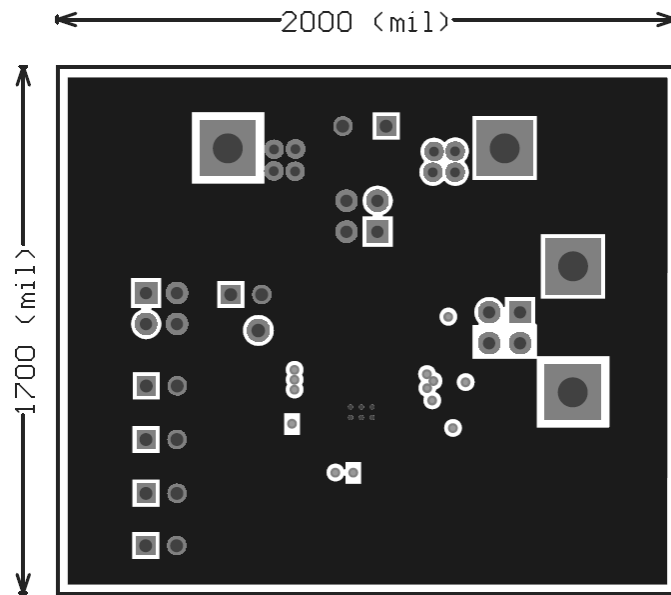

MIC22405 Evaluation Board Mid-Layer 1 (Ground Plane)

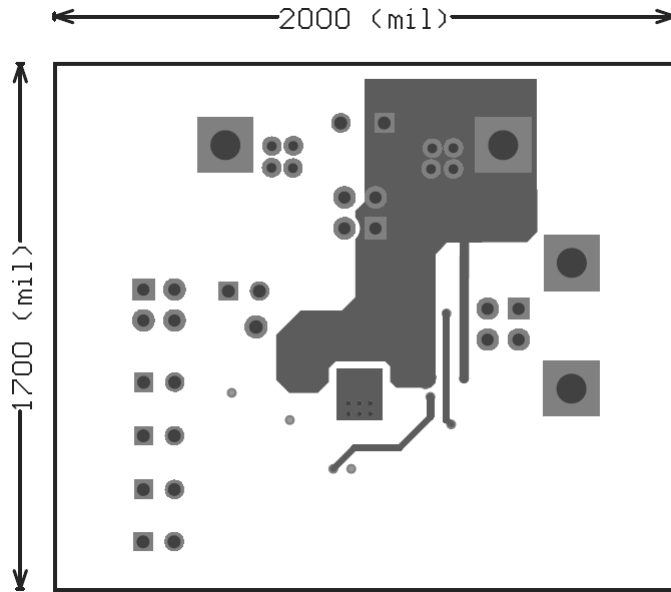

MIC22405 Evaluation Board Mid-Layer 2

Evaluation Board PCB Layout (Continued)

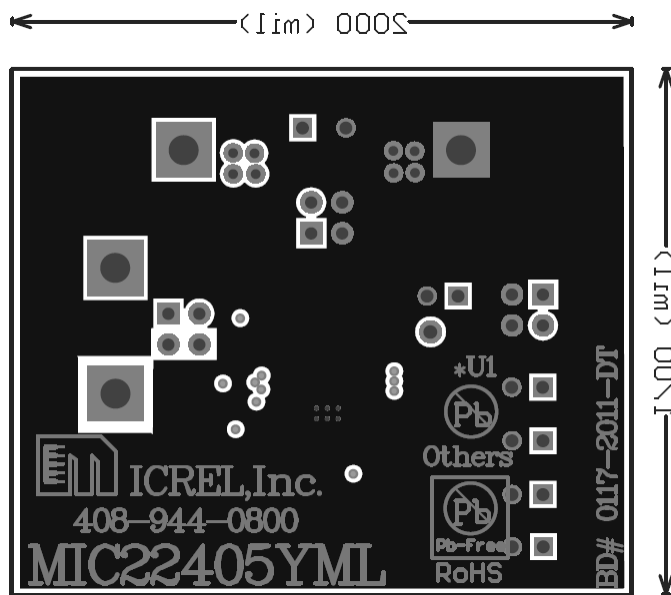

MIC22405 Evaluation Board Bottom Layer

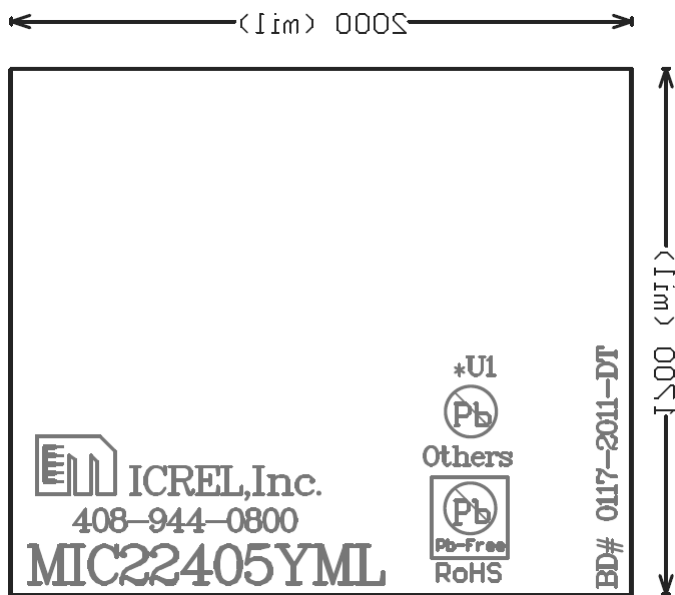

MIC22405 Evaluation Board Bottom Silk

MICREL, INC. 2180 FORTUNE DRIVE SAN JOSE, CA 95131 USA
TEL +1 (408) 944-0800 FAX +1 (408) 474-1000 WEB <http://www.micrel.com>

Micrel makes no representations or warranties with respect to the accuracy or completeness of the information furnished in this data sheet. This information is not intended as a warranty and Micrel does not assume responsibility for its use. Micrel reserves the right to change circuitry, specifications and descriptions at any time without notice. No license, whether express, implied, arising by estoppel or otherwise, to any intellectual property rights is granted by this document. Except as provided in Micrel's terms and conditions of sale for such products, Micrel assumes no liability whatsoever, and Micrel disclaims any express or implied warranty relating to the sale and/or use of Micrel products including liability or warranties relating to fitness for a particular purpose, merchantability, or infringement of any patent, copyright or other intellectual property right

Micrel Products are not designed or authorized for use as components in life support appliances, devices or systems where malfunction of a product can reasonably be expected to result in personal injury. Life support devices or systems are devices or systems that (a) are intended for surgical implant into the body or (b) support or sustain life, and whose failure to perform can be reasonably expected to result in a significant injury to the user. A Purchaser's use or sale of Micrel Products for use in life support appliances, devices or systems is a Purchaser's own risk and Purchaser agrees to fully indemnify Micrel for any damages resulting from such use or sale.

© 2010 Micrel, Incorporated.

X-ON Electronics

Largest Supplier of Electrical and Electronic Components

Click to view similar products for [Switching Voltage Regulators](#) category:

Click to view products by [Microchip](#) manufacturer:

Other Similar products are found below :

[FAN53610AUC33X](#) [FAN53611AUC123X](#) [FAN48610BUC33X](#) [FAN48610BUC45X](#) [FAN48617UC50X](#) [R3](#) [430464BB](#) [KE177614](#)
[MAX809TTR](#) [NCV891234MW50R2G](#) [NCP81103MNTXG](#) [NCP81203PMNTXG](#) [NCP81208MNTXG](#) [NCP81109GMNTXG](#)
[SCY1751FCCT1G](#) [NCP81109JMNTXG](#) [AP3409ADNTR-G1](#) [NCP81241MNTXG](#) [LTM8064IY](#) [LT8315EFE#TRPBF](#) [LTM4668AIY#PBF](#)
[NCV1077CSTBT3G](#) [XCL207A123CR-G](#) [MPM54304GMN-0002](#) [MPM54304GMN-0003](#) [XDPE132G5CG000XUMA1](#) [MP8757GL-P](#)
[MIC23356YFT-TR](#) [LD8116CGL](#) [HG2269M/TR](#) [OB2269](#) [XD3526](#) [U6215A](#) [U6215B](#) [U6620S](#) [LTC3803ES6#TR](#) [LTC3803ES6#TRM](#)
[LTC3412IFE](#) [LT1425IS](#) [MAX25203BATJA/VY+](#) [MAX77874CEWM+](#) [XC9236D08CER-G](#) [ISL95338IRTZ](#) [MP3416GJ-P](#) [BD9S201NUX-CE2](#) [MP5461GC-Z](#) [MPQ4415AGQB-Z](#) [MPQ4590GS-Z](#) [MCP1603-330IMC](#) [MCP1642B-18IMC](#)