



MIC2786/7/8/9 Evaluation Board

Push-Button Reset IC

General Description

The MIC2786/7/8/9 are low-current, ultra-small, push-button reset supervisors with long set-up delays. All the devices feature two manual reset inputs and two reset outputs. The devices initiate a reset for the reset timeout period when the /MR0 and /MR1 inputs are asserted low for a period longer than the set-up delay.

In addition, the MIC2786 and MIC2787 feature an integrated supply voltage monitor. Reset will be asserted for the reset timeout delay once the supply voltage increases above the rising threshold voltage.

The MIC2786 and MIC2788 feature integrated pull-up resistors on the /MR0 and /MR1 inputs, while the MIC2787 and MIC2789 require external pull-up resistors. The PDY input pin selects between a 2s, 4s, or 6s set-up period. Factory-programmed reset timeout periods of 140ms (minimum) and 240ms (minimum) are available.

The MIC2788-XYMT EV Evaluation Board comes with the MIC2788-XYMT ($t_{\text{RESET}} = 140\text{ms}$) installed, but it can also be used to evaluate the MIC2786, MIC2787 and MIC2789. Contact Micrel or an authorized distributor for samples and simply replace the chip on board, as these devices are all pin-to-pin compatible.

For the MIC2787 and MIC2789, positions R1 and R2 will need to be populated with 100k Ω resistors.

Datasheets and support documentation can be found on Micrel's web site at: www.micrel.com.

Requirements

The MIC2788 Evaluation Board requires only a single power supply that is capable of delivering greater than 1mA at a voltage range of 1.5V to 5.5V. An oscilloscope can be used to view and measure the inputs and outputs.

Precautions

There is no reverse input protection on this board. While connecting supplies and signals ensure that correct polarities are observed. The maximum operating VIN is rated at 5.5V.

Getting Started

1. VIN Supplies

Connect a supply to the VIN and GND terminals, paying careful attention to the polarity and the supply range ($1.5\text{V} \leq \text{VIN} \leq 5.5\text{V}$). An ammeter may be placed between the input supply and the VIN terminal to the evaluation board. Ensure that the supply voltage is monitored at the VIN terminal. The ammeter can reduce the voltage supplied to the input.

2. Connect PDY Pin (J5)

Connect the programmable delay input (PDY) pin according to desired set-up delay. Leave PDY pin open for setup-delay of 2s, connect to GND for set-up delay of 4s or connect to VIN for set-up delay of 6s.

3. Monitor Inputs and Outputs

Monitor the inputs (/MR0 and /MR1) and outputs (/RST and RSTP) with an oscilloscope.

4. Turn on the Power

Turn on the power supply. Observe that /MR0, /MR1 and /RST are pulled up to VIN while RSTP remains at 0V.

5. Press Push-Buttons

Press push-button inputs /MR0 and /MR1 and observe /RST and RSTP outputs. Keeping the push-button inputs asserted low for the programmed setup delay time initiates one reset output pulse for the reset timeout delay period.

Ordering Information

Part Number	Description
MIC2788-XYMT EV	MIC2788 Evaluation Board

MLF and MicroLeadFrame are trademarks of Amkor Technology, Inc.

Micrel Inc. • 2180 Fortune Drive • San Jose, CA 95131 • USA • tel +1 (408) 944-0800 • fax + 1 (408) 474-1000 • <http://www.micrel.com>

Evaluation Board Features

See the MIC2788/MIC2789 datasheet for detailed explanations of these functions. For detailed operation of the MIC2786/MIC2787 see the MIC2786/MIC2787 datasheet.

Programmable Delay Pin (PDY)

Use Table 1 to program the PDY pin for desired set-up delay time.

PDY Configuration (J5)	t_{SETUP}
OPEN	2s
GND	4s
V_{IN}	6s

Table 1. PDY Configuration for Desired Set-Up Delay

Figures 1, 2 and 3 illustrate manual reset function for set-up delays as per PDY pin connection.

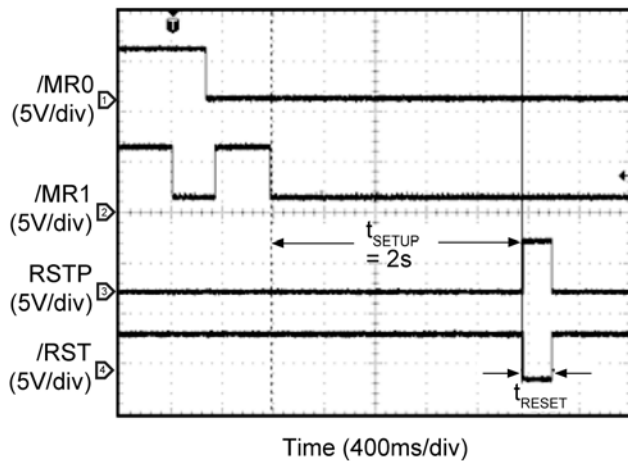

Figure 1. Manual Reset Function for 2.0s Set-Up Delay (PDY = OPEN)

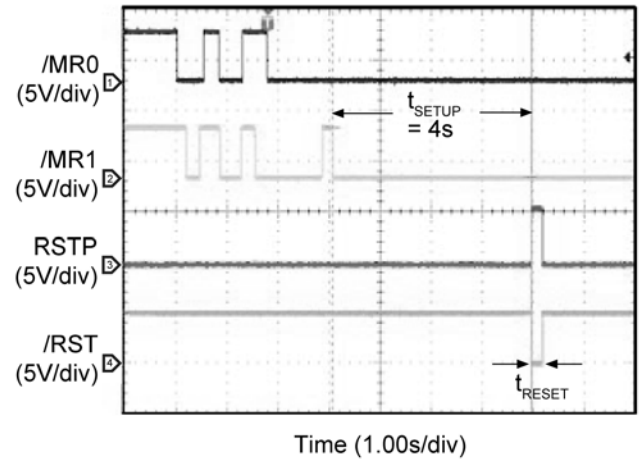

Figure 2. Manual Reset Function for 4.0s Set-Up Delay (PDY = GND)

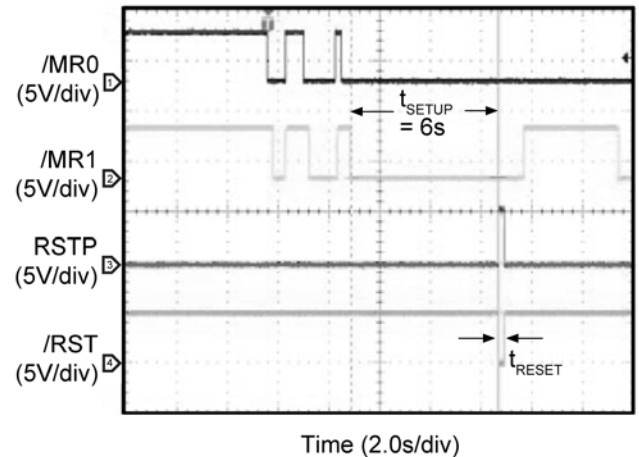

Figure 3. Manual Reset Function for 6.0s Set-Up Delay (PDY = VIN)

Dual Manual Reset Inputs (/MR0, /MR1)

The manual reset inputs can be operated manually using the push-buttons provided or by connecting a function generator. Test points J1 – J4 are provided on the manual reset inputs for connecting to a function generator and monitoring on an oscilloscope simultaneously.

Reset Outputs (/RST, RSTP)

The /RST output has a 100kΩ pull-up resistor to V_{IN} . Test-point J7 is provided for monitoring the /RST signal on an oscilloscope. The RSTP output can be monitored directly by an oscilloscope connected to the test-point J6.

Evaluation Board Schematic

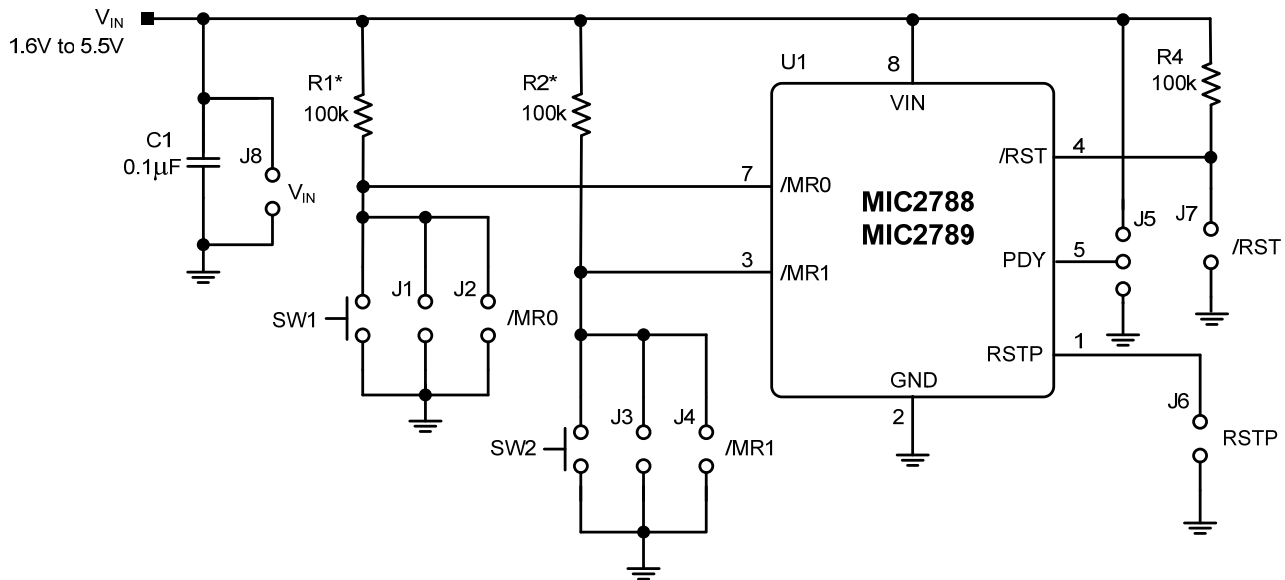

*RESISTORS R1 AND R2 ARE REQUIRED FOR MIC2787 AND MIC2789. R1 AND R2 ARE NOT REQUIRED FOR MIC2786 AND MIC2788.

Bill of Materials

Item	Part Number	Manufacturer	Description	Qty.
C1	GRM188R71C104KA01D	Murata ⁽¹⁾	0.1µF, 16V capacitor, X7R, 0603	1
R4	CRCW0603100KJNEA	Vishay ⁽²⁾	100k, 5% resistor, 0603	1
R1, R2	DNP			0
U1	MIC2788-XYMT	Micrel, Inc. ⁽³⁾	Push-Button Reset IC	1

Notes:

1. Murata: www.murata.com.
2. Vishay: www.vishay.com.
3. Micrel, Inc.: www.micrel.com.

PCB Layout Recommendations

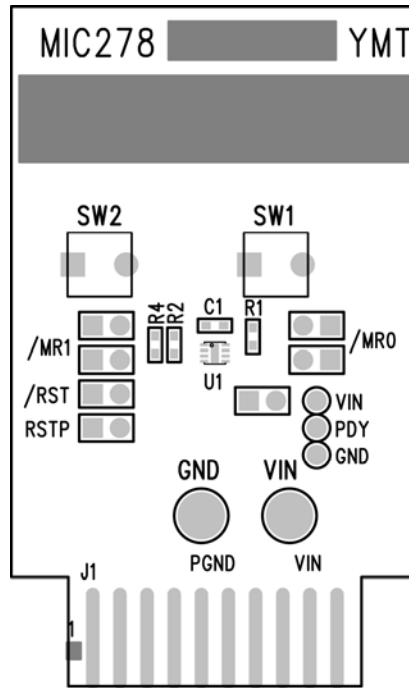

Top Silkscreen

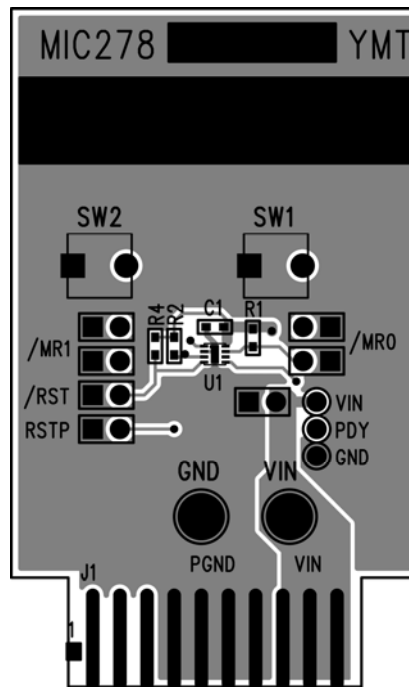

Copper Layer 1

PCB Layout Recommendations (Continued)

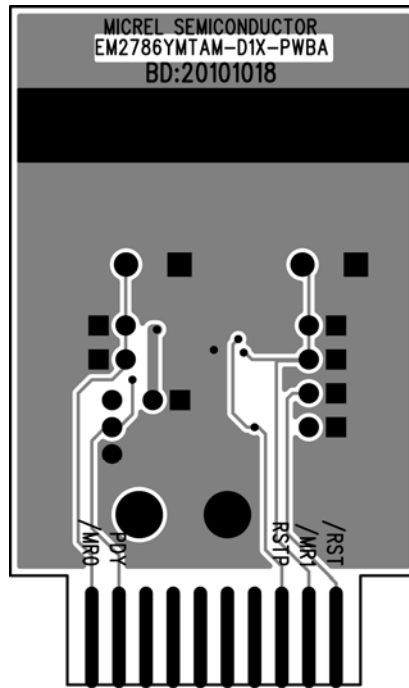

Copper Layer 2

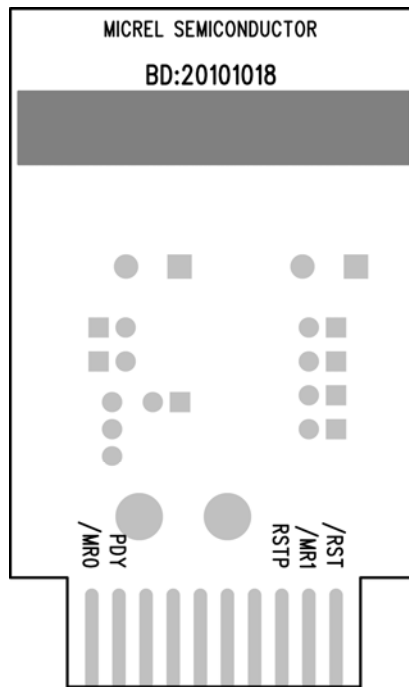

Bottom Silkscreen

MICREL, INC. 2180 FORTUNE DRIVE SAN JOSE, CA 95131 USA
TEL +1 (408) 944-0800 FAX +1 (408) 474-1000 WEB <http://www.micrel.com>

Micrel makes no representations or warranties with respect to the accuracy or completeness of the information furnished in this data sheet. This information is not intended as a warranty and Micrel does not assume responsibility for its use. Micrel reserves the right to change circuitry, specifications and descriptions at any time without notice. No license, whether express, implied, arising by estoppel or otherwise, to any intellectual property rights is granted by this document. Except as provided in Micrel's terms and conditions of sale for such products, Micrel assumes no liability whatsoever, and Micrel disclaims any express or implied warranty relating to the sale and/or use of Micrel products including liability or warranties relating to fitness for a particular purpose, merchantability, or infringement of any patent, copyright or other intellectual property right.

Micrel Products are not designed or authorized for use as components in life support appliances, devices or systems where malfunction of a product can reasonably be expected to result in personal injury. Life support devices or systems are devices or systems that (a) are intended for surgical implant into the body or (b) support or sustain life, and whose failure to perform can be reasonably expected to result in a significant injury to the user. A Purchaser's use or sale of Micrel Products for use in life support appliances, devices or systems is a Purchaser's own risk and Purchaser agrees to fully indemnify Micrel for any damages resulting from such use or sale.

© 2012 Micrel, Incorporated.

X-ON Electronics

Largest Supplier of Electrical and Electronic Components

Click to view similar products for [Supervisory Circuits](#) category:

Click to view products by [Microchip](#) manufacturer:

Other Similar products are found below :

[NCP304LSQ38T1G](#) [NCP304LSQ42T1G](#) [NCP304LSQ43T1G](#) [NCP305LSQ11T1G](#) [NCP305LSQ16T1G](#) [NCP305LSQ17T1G](#)
[NCP305LSQ18T1G](#) [NCP305LSQ24T1G](#) [NCP305LSQ25T1G](#) [NCP305LSQ29T1G](#) [NCP305LSQ31T1G](#) [NCP305LSQ32T1G](#)
[NCP308MT250TBG](#) [NCP308SN300T1G](#) [NCP391FCALT2G](#) [NCV303LSN42T1G](#) [CAT1161LI-25-G](#) [CAT853STBI-T3](#) [CAT1026LI-30-G](#)
[CAT1320LI-25-G](#) [CAT872-30ULGT3](#) [NCP304HSQ18T1G](#) [NCP304HSQ29T1G](#) [NCP304LSQ27T1G](#) [NCP304LSQ29T1G](#)
[NCP304LSQ45T1G](#) [NCP305LSQ26T1G](#) [NCP305LSQ35T1G](#) [NCP305LSQ37T1G](#) [NCP308MT300TBG](#) [NCV300LSN36T1G](#)
[NCV302LSN30T1G](#) [NCV303LSN16T1G](#) [NCV303LSN22T1G](#) [NCV303LSN27T1G](#) [NCV33161DMR2G](#) [TC54VN2402EMB713](#)
[MCP1316T-44NE/OT](#) [MCP1316MT-45GE/OT](#) [MCP1316MT-23LI/OT](#) [MCP1316T-26LE/OT](#) [MAX8997EWW+](#) [MAX821RUS+T](#)
[MAX6725AKASYD3-LF-T](#) [MAX809SEUR](#) [MAX6701LKA+](#) [MAX16126TCA+T](#) [MAX16046ATN+](#) [NCP303LSN09T2G](#)
[NCP304LSQ20T1G](#)