



MIC4478/79/80 Evaluation Board

32V Low-Side Dual MOSFET Drivers

General Description

The MIC4478, MIC4479, and MIC4480 are low-side dual MOSFET drivers. They are designed to switch N-channel enhancement type MOSFETs from TTL-compatible control signals for low-side switching applications. The MIC4478 is dual non-inverting, the MIC4479 is dual inverting, and the MIC4480 has complimentary non-inverting and inverting drivers. Short propagation delays and high peak currents produce precise edges and rapid rise and fall times. The MIC4478/4479/4480 are powered from a +4.5V to +32V supply voltage. The on-state gate drive output voltage is approximately equal to the supply voltage (no internal regulators or clamps). In a low-side configuration, the drivers can control a MOSFET that switches any voltage up to the rating of the MOSFET. The MIC4478/4479/4480 are available in an 8-lead SOIC (ePAD and non-ePAD) package and rated for -40°C to $+125^{\circ}\text{C}$ ambient temperature range.

Data sheets and support documentation are available on Micrel's web site at: www.micrel.com.

Evaluation Board Description

Control IC MIC4478/MIC4479/MIC4480
Topology..... Dual Low-Side MOSFET Driver with Enable
 V_{DD} Supply Voltage Range⁽¹⁾ 4.5V to 32V
Maximum Input Pin Voltage V_{DD}
Maximum Enable Pin Voltage V_{DD}
Maximum External FET Supply Voltage (V_{IN}) 100V

Note:

1. V_{DD} must be less than 18V so as not to exceed the maximum FET V_{GS} rating.

Features

- External MOSFETs on the board to simplify testing.
- Resistor and capacitor component locations on the driver outputs for ease of testing.

Requirements

The evaluation board requires:

- A V_{DD} power supply with an output between 4.5V and 32V to power the driver. While the driver can operate up to 32V, do not exceed 18V when using the MOSFETs that come with this evaluation board.
- An external V_{IN} supply voltage for powering the MOSFET drains. Do not exceed the 100V V_{DS} rating of the MOSFETs.

Precautions

- Ensure the V_{DD} supply does not exceed the maximum V_{GS} of the MOSFETs being used. $V_{GS(ABS_MAX)}$ for the MOSFETs that come with the evaluation board is 20V. 18V maximum is recommended.
- The evaluation board does not have reverse polarity protection. Applying a negative voltage to V_{DD} or V_{IN} may damage the device. Do not exceed 32V on the input, nor exceed the MOSFET's $V_{GS(MAX)}$ to prevent damage to the driver and MOSFETs. Do not exceed 100V on either of the two DRAIN_A or DRAIN_B terminals.

Ordering Information

Part Number	Description
MIC4478YML EV	MIC4478YML Evaluation Board
MIC4479YML EV	MIC4479YML Evaluation Board
MIC4480YML EV	MIC4480YML Evaluation Board

Getting Started

1. Connect the V_{DD} and GND terminals to an external supply voltage. The input voltage range is from 4.5V to 18V. The 18V maximum is limited by the V_{GS} of the MOSFETs.
2. Apply a square wave or pulse to the INA and/or INB terminals. The logic 0 level is less than 0.8V and the logic 1 level is greater than 2.4V. Do not exceed V_{DD} on the inputs. Headers TP1 and TP4 may be used to apply or monitor the input signal.
3. The output signal can be monitored with a scope probe at the OUT_A and OUT-B pins. Headers TP3 and TP6 may also be used to monitor the output signals.

ENA and ENB Inputs

The ENA and ENB inputs are each accessible through a 3-pin header. The EN pins are internally pulled up and do not need a jumper or external signal for the outputs to be enabled. The outputs can be individually disabled with a low signal or a shorting jumper connected from EN to ground. Headers JP2 and JP3 can be used to apply or monitor the enable signals.

INA and INB Inputs

The output drivers are controlled by the INA and INB signal. [Table 1](#) shows the output state based on the input for each of the three drivers. Do not leave the inputs floating when V_{DD} is applied.

Table 1. Input Configuration

Device	INA (Pin 2)	INB (Pin 4)	OUTA (Pin 7)	OUTB (Pin 5)
MIC4478	L/H	L/H	L/H	L/H
MIC4479	L/H	L/H	H/L	H/L
MIC4480	L/H	L/H	H/L	L/H

OUTA and OUTB Outputs

The evaluation board allows the option of driving a MOSFET or capacitance. The board is populated with a 100V N-channel MOSFET to show “real world” operation. The MOSFET may be removed and a capacitor used if standardized testing is needed. Capacitor locations C3 (OUT_A) and C6 (OUT_B) may be used for capacitive testing.

Resistor locations R4 and R9 allow a resistor to be placed in series with the driver output. The board comes with the resistor pads shorted with etch. The etch between the pads of the resistor must be cut before a resistor is added.

External MOSFETs

A pair of 100V MOSFETs are included with the board to facilitate testing of the driver. Terminals are provided for an external supply. A 1k Ω resistor is connected in series between each of the supply inputs and MOSFET drains. This limits the current flowing through the MOSFETs and allows the switching waveform to be observed. These resistors may be changed or removed, depending on the application. A 4.7 μ F capacitor, from the supply terminal to ground, is provided for decoupling the high frequency switching currents. The capacitors and MOSFETs are rated to 100V.

Evaluation Board Schematic

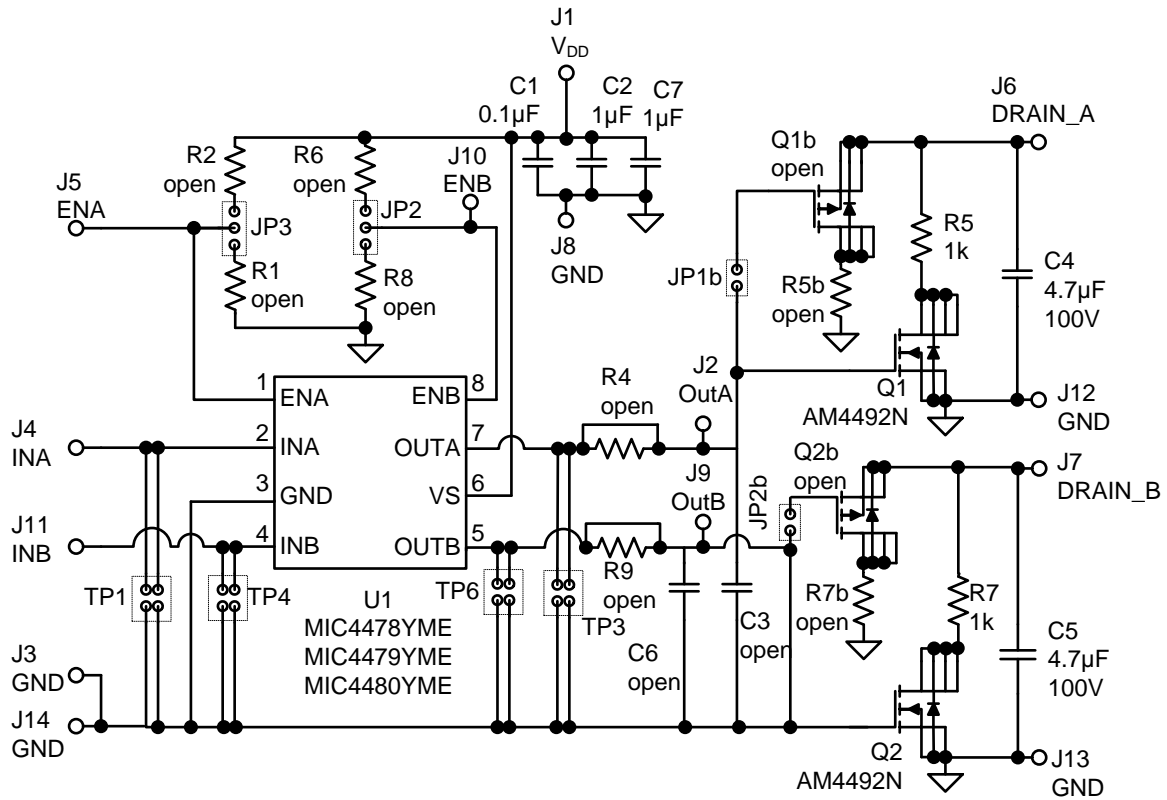

Bill of Materials

Item	Part Number	Manufacturer	Description	Qty.
C1	C1608X7R1H104K080AA	TDK ⁽²⁾	0.1 μ F Ceramic Capacitor, 50V, X7R, Size 0603	1
C2, C7	C3126X5R1H105K160AA	TDK	1 μ F Ceramic Capacitor, 50V, X5R, Size 1206	1
C3, C6			Open Location, Size 0603	2
C4, C5	C3225X7S2A475M200AB	TDK	4.7 μ F Ceramic Capacitor, 100V, X7S, Size 1210	2
Q1, Q2	AM4492N	Analog Power ⁽³⁾	100V, N-Channel MOSFET, SOIC-8	2
R1, R2, R4, R5b, R6, R7b, R8, R9			Open Location, Size 0603	8
R5, R7	CRCW12061001FRT1	Vishay ⁽⁴⁾	1k Ω Resistor (1206 size), 1%	2
U1	MIC4478YME	Micrel, Inc. ⁽⁵⁾	32V Low-Side Dual MOSFET Driver	1
	MIC4479YME			
	MIC4480YME			

Notes:

2. TDK: www.tdk.com.
3. Analog Power: www.analogpowerinc.com.
4. Vishay: www.vishay.com.
5. Micrel, Inc.: www.micrel.com.

PCB Layout Recommendations

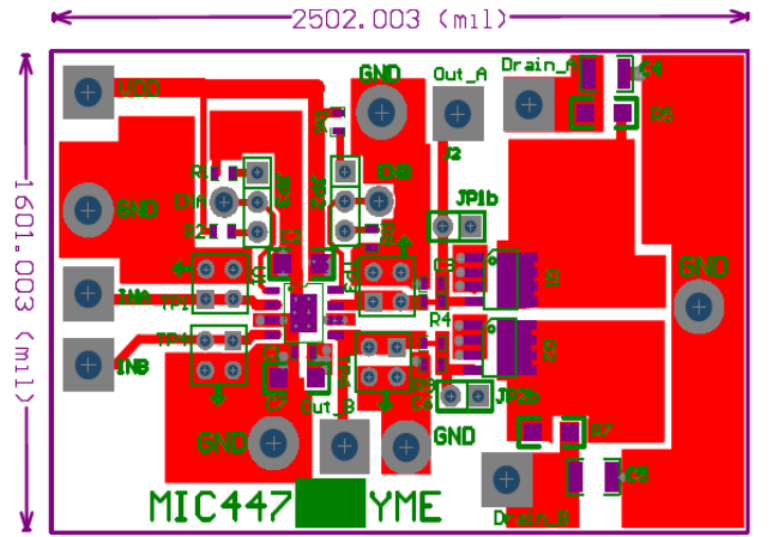

Top Layer

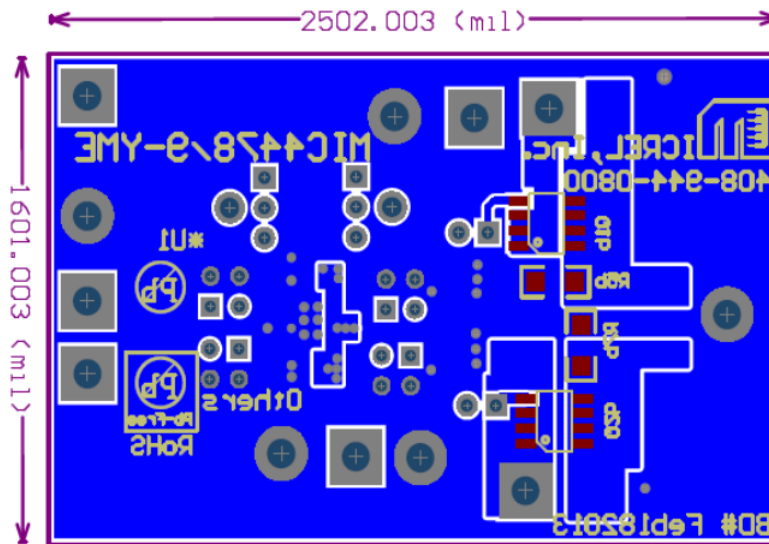

Bottom Layer

MICREL, INC. 2180 FORTUNE DRIVE SAN JOSE, CA 95131 USA
TEL +1 (408) 944-0800 FAX +1 (408) 474-1000 WEB <http://www.micrel.com>

Micrel, Inc. is a leading global manufacturer of IC solutions for the worldwide high performance linear and power, LAN, and timing & communications markets. The Company's products include advanced mixed-signal, analog & power semiconductors; high-performance communication, clock management, MEMs-based clock oscillators & crystal-less clock generators, Ethernet switches, and physical layer transceiver ICs. Company customers include leading manufacturers of enterprise, consumer, industrial, mobile, telecommunications, automotive, and computer products. Corporation headquarters and state-of-the-art wafer fabrication facilities are located in San Jose, CA, with regional sales and support offices and advanced technology design centers situated throughout the Americas, Europe, and Asia. Additionally, the Company maintains an extensive network of distributors and reps worldwide.

Micrel makes no representations or warranties with respect to the accuracy or completeness of the information furnished in this datasheet. This information is not intended as a warranty and Micrel does not assume responsibility for its use. Micrel reserves the right to change circuitry, specifications and descriptions at any time without notice. No license, whether express, implied, arising by estoppel or otherwise, to any intellectual property rights is granted by this document. Except as provided in Micrel's terms and conditions of sale for such products, Micrel assumes no liability whatsoever, and Micrel disclaims any express or implied warranty relating to the sale and/or use of Micrel products including liability or warranties relating to fitness for a particular purpose, merchantability, or infringement of any patent, copyright, or other intellectual property right.

Micrel Products are not designed or authorized for use as components in life support appliances, devices or systems where malfunction of a product can reasonably be expected to result in personal injury. Life support devices or systems are devices or systems that (a) are intended for surgical implant into the body or (b) support or sustain life, and whose failure to perform can be reasonably expected to result in a significant injury to the user. A Purchaser's use or sale of Micrel Products for use in life support appliances, devices or systems is a Purchaser's own risk and Purchaser agrees to fully indemnify Micrel for any damages resulting from such use or sale.

© 2015 Micrel, Incorporated.

X-ON Electronics

Largest Supplier of Electrical and Electronic Components

Click to view similar products for [MOSFET](#) category:

Click to view products by [Microchip](#) manufacturer:

Other Similar products are found below :

[614233C](#) [648584F](#) [MCH3443-TL-E](#) [MCH6422-TL-E](#) [FW231A-TL-E](#) [APT5010JVR](#) [NTNS3A92PZT5G](#) [IRF100S201](#) [JANTX2N5237](#)
[2SK2464-TL-E](#) [2SK3818-DL-E](#) [FCA20N60_F109](#) [FDZ595PZ](#) [STD6600NT4G](#) [FSS804-TL-E](#) [2SJ277-DL-E](#) [2SK1691-DL-E](#) [2SK2545\(Q,T\)](#)
[D2294UK](#) [405094E](#) [423220D](#) [MCH6646-TL-E](#) [TPCC8103,L1Q\(CM](#) [367-8430-0972-503](#) [VN1206L](#) [424134F](#) [026935X](#) [051075F](#)
[SBVS138LT1G](#) [614234A](#) [715780A](#) [NTNS3166NZT5G](#) [751625C](#) [873612G](#) [IRF7380TRHR](#) [IPS70R2K0CEAKMA1](#) [RJK60S3DPP-E0#T2](#)
[RJK60S5DPK-M0#T0](#) [APT5010JVFR](#) [APT12031JFLL](#) [APT12040JVR](#) [DMN3404LQ-7](#) [NTE6400](#) [JANTX2N6796U](#) [JANTX2N6784U](#)
[JANTXV2N5416U4](#) [SQM110N05-06L-GE3](#) [SIHF35N60E-GE3](#) [2SK2614\(TE16L1,Q\)](#) [2N7002KW-FAI](#)