



MIC45208 Evaluation Board

26V/10A DC-to-DC Power Module

General Description

Micrel's MIC45208 is a synchronous step-down regulator module, featuring a unique adaptive ON-time control architecture. The module incorporates a DC-to-DC controller, power MOSFETs, bootstrap diode, bootstrap capacitor, and an inductor in a single package; simplifying the design and layout process for the end user.

This highly-integrated solution expedites system design and improves product time-to-market. The internal MOSFETs and inductor are optimized to achieve high efficiency at a low output voltage. The fully optimized design can deliver up to 10A current under a wide input voltage range of 4.5V to 26V, without requiring additional cooling.

The MIC45208-1 uses Micrel's HyperLight Load[®] (HLL) MIC45208-2 uses Micrel's Hyper Speed Control[™] architecture which enables ultra-fast load transient response, allowing for a reduction of output capacitance. The MIC45208 offers 1% output accuracy that can be adjusted from 0.8V to 5.5V with two external resistors.

The basic parameters of the evaluation board are:

- Input: 4.5V to 26V
- Output: 0.8V to 5V at 10A
- 600kHz Switching Frequency (Adjustable 200kHz to 600kHz)

Datasheets and support documentation are available on Micrel's web site at: www.micrel.com.

Requirements

The MIC45208-1 and MIC45208-2 evaluation board only requires a single power supply with at least 10A current capability. No external linear regulator is required to power the internal biasing of the IC because the MIC45208 has an internal PVDD LDO. In applications where $V_{IN} < +5.5V$, PVDD should be tied to VIN to bypass the internal linear regulator. The output load can either be a passive or an active load.

Precautions

The MIC45208 evaluation board does not have reverse polarity protection. Applying a negative voltage to the VIN and GND terminals can damage the device. The maximum VIN of the board is rated at 30V. Exceeding 30V on the VIN could damage the device.

HyperLight Load is a registered trademark and Hyper Speed Control is a trademark of Micrel, Inc.

Micrel Inc. • 2180 Fortune Drive • San Jose, CA 95131 • USA • tel +1 (408) 944-0800 • fax + 1 (408) 474-1000 • <http://www.micrel.com>

Getting Started

1. VIN Supply

Connect a power supply to the VIN and GND terminals, paying careful attention to the polarity and the supply range ($4.5V < V_{IN} < 26V$). Monitor IIN with a current meter and monitor input voltage at VIN and GND terminals with a voltmeter. Do not apply power until Step 4.

2. Connect Load and Monitor Output

Connect a load to the VOUT and GND terminals. The load can be either a passive (resistive) or an active (as in an electronic load) type. A current meter may be placed between the VOUT terminal and load to monitor the output current. Ensure the output voltage is monitored at the VOUT terminal.

3. Enable Input

The EN pin has an on-board 100kΩ pull-up resistor (R10) to VIN, which allows the output to be turned on when PVDD exceeds its UVLO threshold. An EN connector is provided on the evaluation board for users to easily access the enable feature. Applying an external logic signal on the EN pin to pull it low or using a jumper to short the EN pin to GND will shut off the output of the MIC45208 evaluation board.

4. Turn Power On

Turn on the VIN supply and verify that the output voltage is regulated to 5V.

Ordering Information

Part Number	Description
MIC45208-1YMP EV	MIC45208-1 Evaluation Board
MIC45208-2YMP EV	MIC45208-2 Evaluation Board

Features

Feedback Resistors

The output voltage on the MIC45208 evaluation board, which is preset to 5.0V, is determined by the feedback divider:

$$V_{\text{OUT}} = V_{\text{REF}} \times \left(1 + \frac{R_{14}}{R_{\text{BOTTOM}}} \right) \quad \text{Eq. 1}$$

where $V_{\text{REF}} = 0.8\text{V}$, and R_{BOTTOM} is one of R3 thru R9. Leaving the R_{BOTTOM} open by removing all jumpers on the feedback headers gives a 0.8V output voltage.

All other voltages not listed above can be set by modifying R_{BOTTOM} value according to:

$$R_{\text{BOTTOM}} = \frac{R_{14} \times V_{\text{REF}}}{V_{\text{OUT}} - V_{\text{REF}}} \quad \text{Eq. 2}$$

Note that the output voltage should not be set to exceed 5V.

Table 1. Typical Values of Some Components

V_{OUT}	V_{IN}	R14 (Top Feedback Resistor)	R (Bottom Feedback Resistor)	C12 (C_{ff})	C_{OUT}
1.0V	5V to 26V	10k Ω	40.2k Ω	2.2nF	100 μ F/6.3V
1.2V	5V to 26V	10k Ω	20k Ω	2.2nF	100 μ F/6.3V
1.5V	5V to 26V	10k Ω	11.5k Ω	2.2nF	100 μ F/6.3V
1.8V	5V to 26V	10k Ω	8.06k Ω	2.2nF	100 μ F/6.3V
2.5V	5V to 26V	10k Ω	4.75k Ω	2.2nF	100 μ F/6.3V
3.3V	5V to 26V	10k Ω	3.24k Ω	2.2nF	100 μ F/6.3V
5V	7V to 26V	10k Ω	1.9k Ω	2.2nF	100 μ F/6.3V

SW Node

Test point TP12 (V_{SW}) is placed for monitoring the switching waveform, which is one of the most critical waveforms for the converter.

Current Limit

The MIC45208 uses the $R_{DS(ON)}$ of the low-side MOSFET and external resistor connected from the ILIM pin to the SW node to decide the current limit.

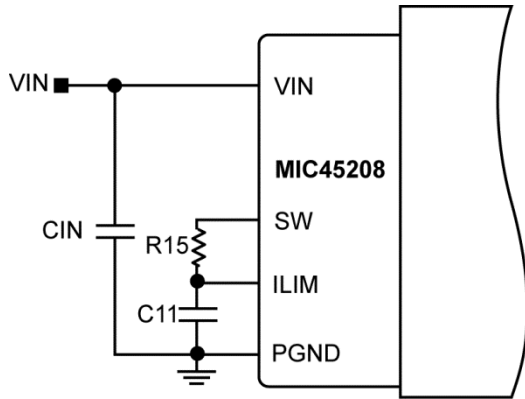

Figure 1. MIC45208 Current Limiting Circuit

During each switching cycle of the MIC45208, the inductor current is sensed by monitoring the low-side MOSFET in the OFF period. The sensed voltage, $V_{(ILIM)}$, is compared with the power ground (PGND) after a blanking time of 150ns. In this way the drop voltage over the resistor R15 (V_{CL}) is compared with the drop over the bottom FET generating the short current limit. The small capacitor (C11) connected from ILIM pin to PGND filters the switching node ringing during the off-time allowing a better short-limit measurement. The time constant created by R15 and C11 should be much less than the minimum off time.

The V_{CL} drop allows programming of short limit through the value of the resistor (R15) if the absolute value of the voltage drop on the bottom FET is greater than V_{CL} . In that case the $V_{(ILIM)}$ is lower than PGND and a short circuit event is triggered. A hiccup cycle to treat the short event is generated. The hiccup sequence including the soft start reduces the stress on the switching FETs and protects the load and supply for severe short conditions.

The short circuit current limit can be programmed by using the following formula:

$$R15 = \frac{(I_{CLIM} - \Delta I_{L(PP)} \times 0.5) \times R_{DS(ON)} + V_{CL}}{I_{CL}} \tag{Eq. 3}$$

I_{CLIM} = Desired current limit

$R_{DS(ON)}$ = On-resistance of low-side power MOSFET, 6mΩ (typ.)

V_{CL} = Current-limit threshold (typical absolute value is 14mV per *Electrical Characteristics* table in MIC45208 datasheet)

I_{CL} = Current-limit source current (typical value is 70μA, per the *Electrical Characteristics* table in MIC45208 datasheet).

$\Delta I_{L(PP)}$ = Inductor current peak-to-peak, since the inductor is integrated use Equation 4 to calculate the inductor ripple current.

The peak-to-peak inductor current ripple is:

$$\Delta I_{L(PP)} = \frac{V_{OUT} \times (V_{IN(MAX)} - V_{OUT})}{V_{IN(MAX)} \times f_{sw} \times L} \tag{Eq. 4}$$

The MIC45208 has 0.8μH inductor integrated into the module. In case of hard short, the short limit is folded down to allow an indefinite hard short on the output without any destructive effect. It is mandatory to make sure that the inductor current used to charge the output capacitance during soft-start is under the folded short limit; otherwise the supply will go in hiccup mode and may not be finishing the soft start successfully.

The MOSFET $R_{DS(ON)}$ varies 30 to 40% with temperature. Therefore, it is recommended to add a 50% margin to I_{CLIM} in the above equation to avoid false current limiting due to increased MOSFET junction temperature rise. With $R15 = 1.37k\Omega$ and $C11 = 15pF$, the typical output current limit is 16.8A.

Setting the Switching Frequency

The MIC45208 switching frequency can be adjusted by changing the value of resistors R1 and R2. The switching frequency also depends on V_{IN} , V_{OUT} , and load conditions.

R2 is selected to set the required switching frequency as shown in [Figure 3](#):

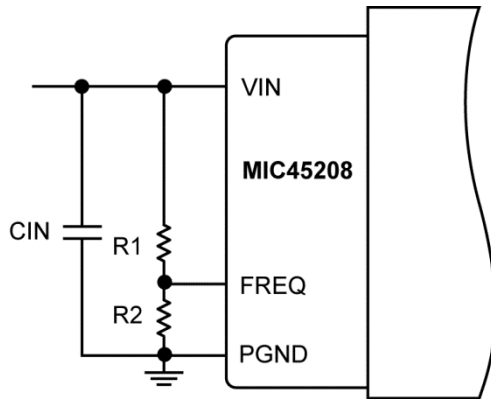

Figure 2. Switching Frequency Adjustment

[Equation 5](#) illustrates the estimated switching frequency:

$$f_{sw} = f_o \times \frac{R2}{R1 + R2} \quad \text{Eq. 5}$$

Where $f_o = 600\text{kHz}$

$R1 = 100\text{k}\Omega$ (recommended)

Switching Frequency

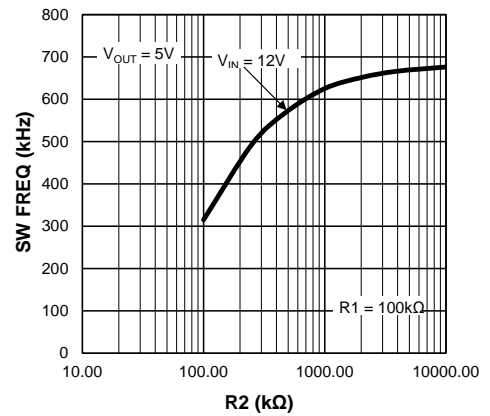
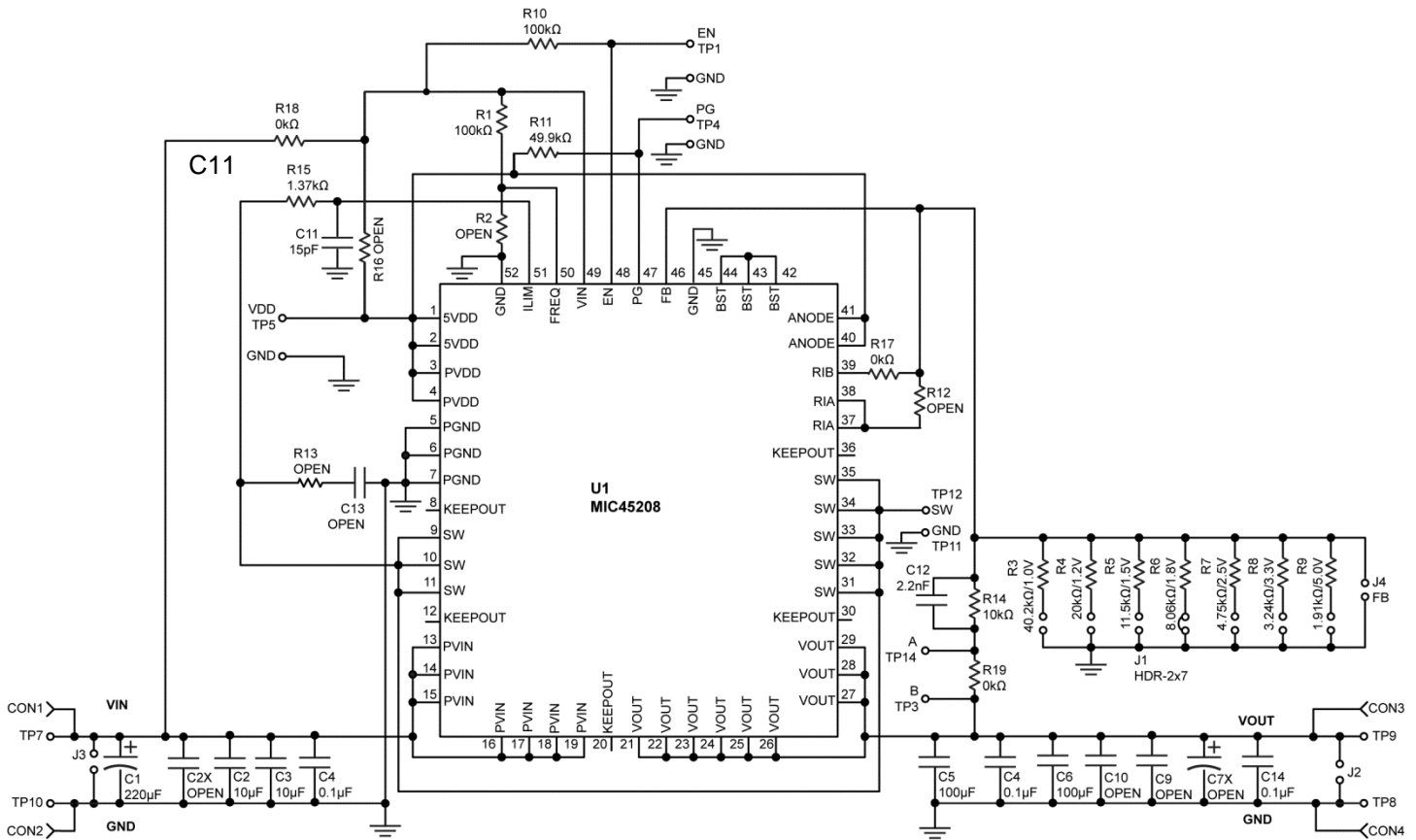

Figure 3. Switching Frequency vs. R2

MIC45208 Evaluation Board Schematic



Bill of Materials

Item	Part Number	Manufacturer	Description	Qty.
C1	B41125A7227M000	TDK ⁽¹⁾	220µF/35V, ALE Capacitor (optional)	1
C2, C3	C3216X5R1H106M160AB	TDK	10µF/50V, 1206, X5R, 10%, MLCC	2
C2X, C9, C10, C7, C7X, C13			Open	6
C4, C8, C14	GRM188R71H104KA93D	Murata ⁽²⁾	0.1µF/50V, X7R, 0603, 10%, MLCC	3
C5, C6	C3216X5R0J107M160AB	TDK	100µF/6.3V, X5R, 1206, 20%, MLCC	2
C11	GRM1885C1H150JA01D	Murata	15pF/50V, NP0, 0603, 5%, MLCC	3
C12	C1608C0G1H222JT	TDK	2.2nF/50V, NP0, 0603, 5%, MLCC	1
CON1, CON2, CON3, CON4	8191k	Keystone ⁽³⁾	15A, 4-Prong Through-Hole Screw Terminal	4

Notes:

1. TDK: www.TDK.com.
2. Murata: www.murata.com.
3. Keystone: www.keyelco.com.

Bill of Materials (Continued)

Item	Part Number	Manufacturer	Description	Qty.
J1	M50-3500742	Harwin ⁽⁴⁾	Header 2x7	1
J2, J3, J4, TP3 – TP5	90120-0122	Molex ⁽⁵⁾	Header 2	6
R1, R10	CRCW0603100K0FKEA	Vishay Dale ⁽⁶⁾	100kΩ, 1%, 1/10W, 0603, Thick Film	2
R2, R12, R13, R16			Open	4
R3	CRCW060340K2FKEA	Vishay Dale	40.2kΩ, 1%, 1/10W, 0603, Thick Film	1
R4	CRCW06020K0FKEA	Vishay Dale	20kΩ, 1%, 1/10W, 0603, Thick Film	1
R5	CRCW060311K5FKEA	Vishay Dale	11.5kΩ, 1%, 1/10W, 0603, Thick Film	1
R6	CRCW06038K06FKEA	Vishay Dale	8.06kΩ, 1%, 1/10W, 0603, Thick Film	1
R7	CRCW06034K75FKEA	Vishay Dale	4.75kΩ, 1%, 1/10W, 0603, Thick Film	1
R8	CRCW06033K24FKEA	Vishay Dale	3.24kΩ, 1%, 1/10W, 0603, Thick Film	1
R9	CRCW06031K91FKEA	Vishay Dale	1.91kΩ, 1%, 1/10W, 0603, Thick Film	1
R11	CRCW060349K9FKEA	Vishay Dale	49.9kΩ, 1%, 1/10W, 0603, Thick Film	1
R14	CRCW060310K0FKEA	Vishay Dale	10kΩ, 1%, 1/10W, 0603, Thick Film	1
R15	CRCW06031K37FKEA	Vishay Dale	1.37kΩ, 1%, 1/10W, 0603, Thick Film	1
R17, R18, R19	RCG06030000Z0EA	Vishay Dale	0Ω Resistor, 1%, 1/10W, 0603, Thick Film	3
TP7 – TP14	1502-2	Keystone	Single-End, Through-Hole Terminal	8
U1	MIC45208-1YMP	Micrel, Inc. ⁽⁷⁾	26V/10A DC-to-DC Power Module	1
	MIC45208-2YMP			

Notes:

4. Harwin: www.harwin.com.
5. Molex: www.molex.com.
6. Vishay-Dale: www.vishay.com.
7. Micrel: www.micrel.com.

PCB Layout Recommendations

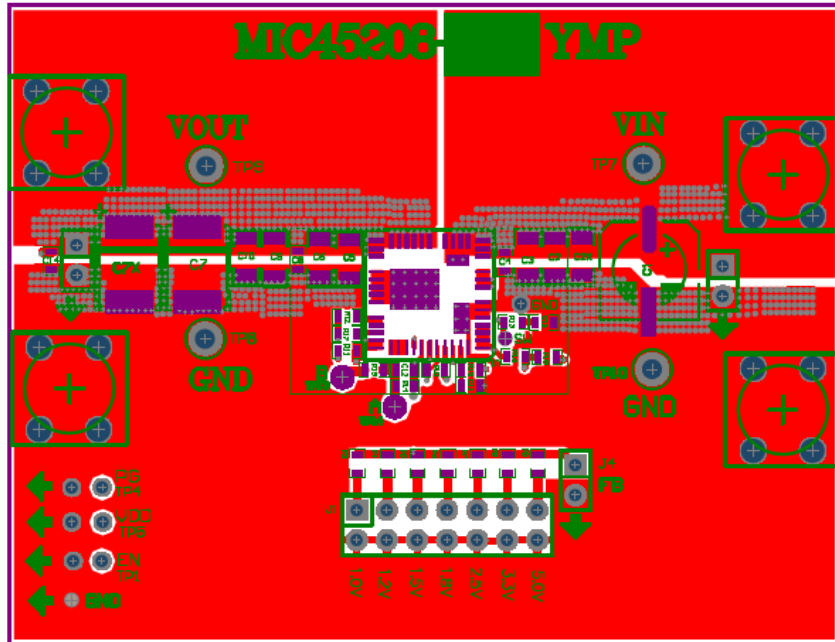

MIC45208 Evaluation Board Top Layer

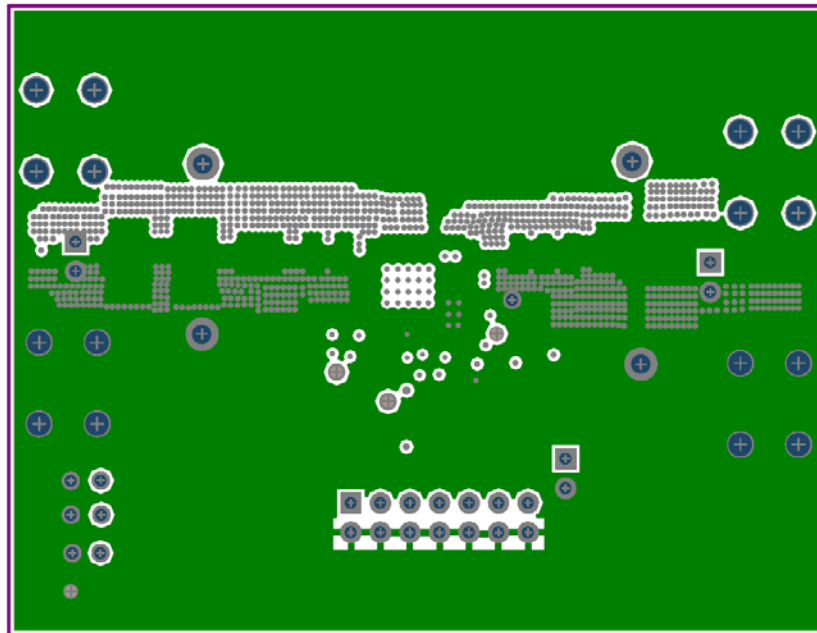

MIC45208 Evaluation Board Copper Layer 2

PCB Layout Recommendations (Continued)

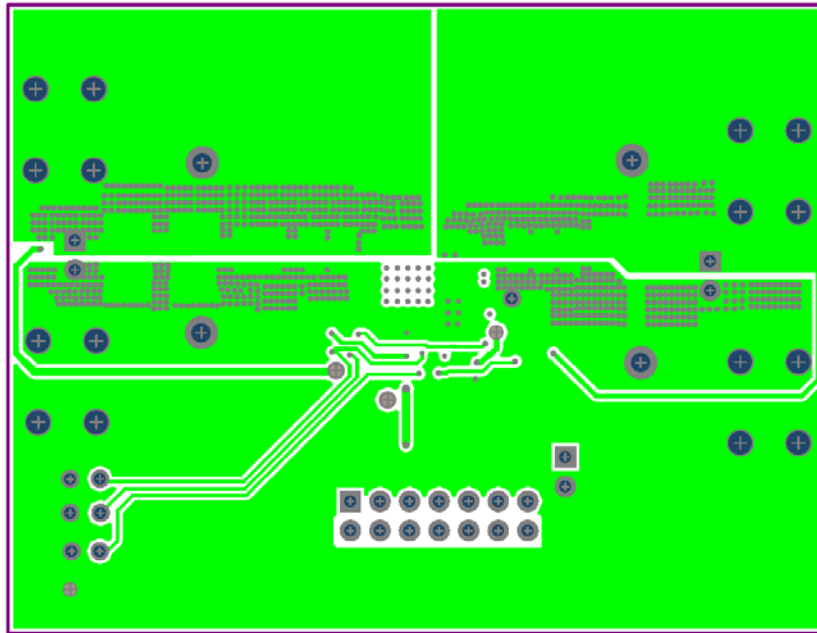

MIC45208 Evaluation Board Copper Layer 3

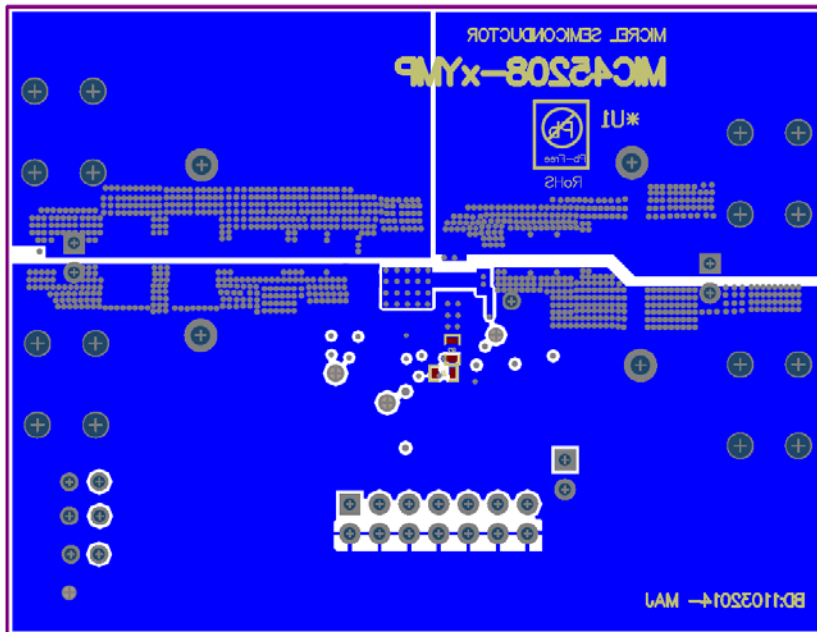

MIC45208 Evaluation Board Bottom Layer

MICREL, INC. 2180 FORTUNE DRIVE SAN JOSE, CA 95131 USA
TEL +1 (408) 944-0800 FAX +1 (408) 474-1000 WEB <http://www.micrel.com>

Micrel, Inc. is a leading global manufacturer of IC solutions for the worldwide high-performance linear and power, LAN, and timing & communications markets. The Company's products include advanced mixed-signal, analog & power semiconductors; high-performance communication, clock management, MEMs-based clock oscillators & crystal-less clock generators, Ethernet switches, and physical layer transceiver ICs. Company customers include leading manufacturers of enterprise, consumer, industrial, mobile, telecommunications, automotive, and computer products. Corporation headquarters and state-of-the-art wafer fabrication facilities are located in San Jose, CA, with regional sales and support offices and advanced technology design centers situated throughout the Americas, Europe, and Asia. Additionally, the Company maintains an extensive network of distributors and reps worldwide.

Micrel makes no representations or warranties with respect to the accuracy or completeness of the information furnished in this datasheet. This information is not intended as a warranty and Micrel does not assume responsibility for its use. Micrel reserves the right to change circuitry, specifications and descriptions at any time without notice. No license, whether express, implied, arising by estoppel or otherwise, to any intellectual property rights is granted by this document. Except as provided in Micrel's terms and conditions of sale for such products, Micrel assumes no liability whatsoever, and Micrel disclaims any express or implied warranty relating to the sale and/or use of Micrel products including liability or warranties relating to fitness for a particular purpose, merchantability, or infringement of any patent, copyright, or other intellectual property right.

Micrel Products are not designed or authorized for use as components in life support appliances, devices or systems where malfunction of a product can reasonably be expected to result in personal injury. Life support devices or systems are devices or systems that (a) are intended for surgical implant into the body or (b) support or sustain life, and whose failure to perform can be reasonably expected to result in a significant injury to the user. A Purchaser's use or sale of Micrel Products for use in life support appliances, devices or systems is a Purchaser's own risk and Purchaser agrees to fully indemnify Micrel for any damages resulting from such use or sale.

© 2015 Micrel, Incorporated.

X-ON Electronics

Largest Supplier of Electrical and Electronic Components

Click to view similar products for [Power Management IC Development Tools](#) category:

Click to view products by [Microchip](#) manufacturer:

Other Similar products are found below :

[EVAL6482H-DISC](#) [EVAL-AD5522EBUZ](#) [EVAL-ADM1060EBZ](#) [EVAL-ADM1073MEBZ](#) [EVAL-ADM1166TQEBZ](#) [EVAL-ADM1168LQEBZ](#) [EVAL-ADM1171EBZ](#) [EVAL-ADM1276EBZ](#) [EVB-EN5319QI](#) [EVB-EN5365QI](#) [EVB-EN6347QI](#) [EVB-EP5348UI](#) [MIC23158YML EV](#) [MIC23451-AAAYFL EV](#) [MIC5281YMME EV](#) [124352-HMC860LP3E](#) [ADM00513](#) [ADM8611-EVALZ](#) [ADM8612-EVALZ](#) [ADM8613-EVALZ](#) [ADP1046ADC1-EVALZ](#) [ADP1055-EVALZ](#) [ADP122-3.3-EVALZ](#) [ADP130-0.8-EVALZ](#) [ADP130-1.2-EVALZ](#) [ADP130-1.5-EVALZ](#) [ADP130-1.8-EVALZ](#) [ADP160UJZ-REDYKIT](#) [ADP166UJ-EVALZ](#) [ADP1712-3.3-EVALZ](#) [ADP1714-3.3-EVALZ](#) [ADP1715-3.3-EVALZ](#) [ADP1716-2.5-EVALZ](#) [ADP1740-1.5-EVALZ](#) [ADP1752-1.5-EVALZ](#) [ADP1754-1.5-EVALZ](#) [ADP1828LC-EVALZ](#) [ADP1870-0.3-EVALZ](#) [ADP1871-0.6-EVALZ](#) [ADP1873-0.6-EVALZ](#) [ADP1874-0.3-EVALZ](#) [ADP1876-EVALZ](#) [ADP1879-1.0-EVALZ](#) [ADP1882-1.0-EVALZ](#) [ADP1883-0.6-EVALZ](#) [ADP197CB-EVALZ](#) [ADP199CB-EVALZ](#) [ADP2102-1.25-EVALZ](#) [ADP2102-1.2-EVALZ](#) [ADP2102-1.875EVALZ](#)