



### General Description

The MIC4830 is a low audible noise 180Vp-p electroluminescent lamp (EL) driver. Using advanced Bipolar, CMOS, DMOS (BCD) technology, the MIC4830 integrates a high voltage boost converter and an H-bridge driver for driving a large EL lamp. The MIC4830 can drive large panel displays for mobile phones, remote controls, MP3 players or automotive electronics where EL panels are used for backlighting.

The MIC4830 offers design flexibility with adjustable lamp and boost converter frequencies simply by applying external set resistors.

Micrel's new H-Bridge design reduces audible noise by creating smoother AC voltage across the EL panel. The smooth AC voltage waveform eliminates sudden changes in voltage, thus reducing the common cause of audible noise in EL drivers.

### Requirements

The MIC4830 evaluation board requires an input power source that is able to deliver greater than 200mA at 1.8V.

### Precautions

The evaluation board does not have reverse polarity protection. Applying a negative voltage to the  $V_{IN}$  terminal may damage the device.

The MIC4830 evaluation board is tailored for a Li-Ion range input supply voltage. It should not exceed 5.5V on the input. The MIC4830 is a high voltage, low current device and should be handled with care to prevent a possible electrical buzz.

### Getting Started

1. **Connect an external supply to  $V_{IN}$ .** Apply desired input voltage to the  $V_{IN}$  (J1) and ground terminal (J2) of the evaluation board, paying careful attention to polarity and supply voltage ( $1.8V \leq V_{IN} \leq 5.5V$ ). An ammeter may be placed between the input supply and the  $V_{IN}$  terminal to the evaluation board. Ensure that the supply voltage is monitored at the  $V_{IN}$  terminal. The ammeter and/or power lead resistance can reduce the voltage supplied to the input.

2. **Connect an EL panel.** Connect the EL panel to the VA (J4) and VB (J5) terminals. Note that polarity of the EL panel does not matter.
3. **Enable/Disable the MIC4830 Boost Regulator.** JP1 is the enable/disable jumper for the Boost Regulator portion of the MIC4830. Connecting JP1 to ground disables the boost regulator and connecting JP1 to  $V_{IN}$  enables the boost regulator. A voltage signal may be applied to the center pin of JP1 to enable or disable the boost regulator. A low voltage signal (0V) will disable the boost regulator and a high voltage equal to  $V_{IN}$  will enable the boost regulator. The enable voltage should rise and fall between high and low monotonically without interruptions.
4. **Enable/Disable the MIC4830 H-Bridge.** JP2 is the enable/disable jumper for the H-Bridge portion of the MIC4830. Connecting JP2 to ground disables the H-Bridge and connecting JP2 to  $V_{IN}$  enables the H-Bridge. Disabling the H-Bridge does not disable the boost regulator.
5. **Enable/Disable the EL panel.** Both the Boost Regulator and the H-Bridge of the MIC4830 must be enabled in order for the EL panel to light up. For minimum shutdown current, both the Boost Regulator and the H-Bridge should be turned off. The EN jumper (JP3) connects the  $V_{IN}$  to the inductor. This jumper may be used to enable or disable the EL panel on the evaluation board, without having to use JP1 and JP2 for evaluation purposes.

### Ordering Information

Part Number	Description
MIC4830YMM EV	180Vpp MSOP Evaluation Board
MIC4830YML EV	180Vpp MLF Evaluation Board

MLF and MicroLeadFrame are a registered trademark of Amkor Technology.

Micrel, Inc. • 2180 Fortune Drive • San Jose, CA 95131 • USA • tel + 1 (408) 944-0800 • fax 1 (408) 474-1000 • <http://www.micrel.com>

December 2007

M9999-122007  
(408) 955-1690

**Boost Regulator Output Voltage**

The boost regulator output voltage is set to 90V. The output peak-to-peak voltage across the EL panel is about 2 times the boost regulator output voltage (180Vp-p).

**EL Panel Size and Equivalent Circuit**

Using laboratory data, it can be shown that the EL panel has an equivalent circuit equal to a series resistance (Rs) with a series capacitance (C) and a parallel resistance (Rp). For example, if an EL panel is 4in<sup>2</sup>, then the equivalent circuit is about 20nF of capacitance in series with 450Ω of resistance and 766kΩ of parallel resistance. Figure 1 and Table 1 shows close approximations of the equivalent circuit for different EL panel sizes.

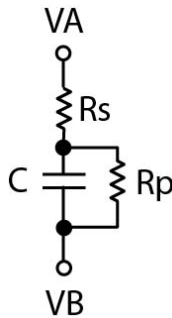

**Figure 1. EL Panel Equivalent Circuit**

**Table 1. EL Panel Equivalent Circuit Components**

Size (in <sup>2</sup> )	0.40	1.0	2.0	3.0	4.0	6.0
C (nF)	2	5	10	15	20	30
Rs (Ω)	4600	1800	900	600	450	300
Rp (MΩ)	7.66	3.05	1.53	1.02	0.766	0.511

**Changing the Boost Regulator Frequency (f<sub>sw</sub>)**

The boost regulator switching frequency may be changed depending upon the value of the R<sub>sw</sub> resistor. The R<sub>sw</sub> resistor on the evaluation board is equal to 332kΩ. The switching frequency may be calculated using the R<sub>sw</sub> resistor by the following equation.

$$f_{sw} \text{ (kHz)} = \frac{36}{R_{sw} \text{ (M}\Omega)}$$

Lowering the switching frequency will deliver more power to the EL panel by the boost regulator; however, the switching frequency of the boost regulator should not be low enough to create overshoot at the SW pin or at the CS pin. Refer to table 2 for recommended values.

**Changing the EL Lamp Frequency, f<sub>EL</sub>**

The EL lamp frequency (H-Bridge frequency) may be changed depending upon the value of the R<sub>EL</sub> resistor. The R<sub>EL</sub> resistor on the evaluation board is equal to 1.78MΩ. The EL lamp frequency may be calculated using the R<sub>EL</sub> resistor by the following equation.

$$f_{EL} \text{ (Hz)} = \frac{360}{R_{EL} \text{ (M}\Omega)}$$

The higher the EL lamp frequency, the brighter the EL panel; however, more brightness will require more input current, thus demand more input power. More power may be delivered to the EL lamp by increasing the input voltage or by lowering the switching frequency of the boost regulator. A table of recommended components for typical EL panel sizes and EL lamp frequency is shown in Figure 2 and Table 2.

### Typical Application Circuit

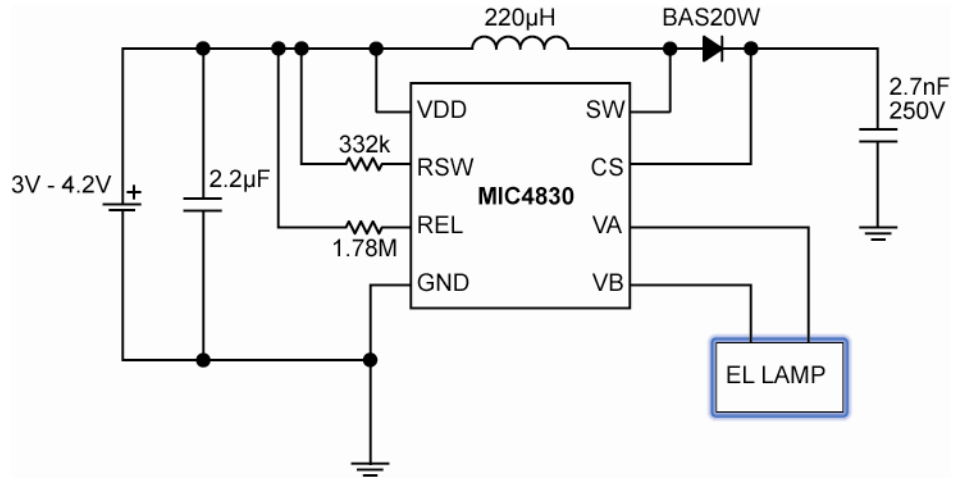

Figure 2. Typical Li-Ion Powered MIC4830 Circuit

Table 2. Recommended  $R_{SW}$  &  $R_{EL}$  values for various EL panel sizes

Size (inch <sup>2</sup> )	Capacitance (nF)	Lamp Frequency (Hz)	100	200	300	400	500	600	700	800	900
		REL (MΩ)	2.82	1.69	1.1	0.837	0.665	0.562	0.471	0.409	0.369
0.4	2	Rsw (kΩ)	225	232	237	248	257	269	281	300	321
		fsw (kHz)	160	155	152	145	140	134	128	120	112
1	5	Rsw (kΩ)	232	250	277	300	346	395	473		
		fsw (kHz)	155	144	130	120	104	91	76		
2	10	Rsw (kΩ)	250	290	352	433	521				
		fsw (kHz)	144	124	102	83	69				
3	15	Rsw (kΩ)	272	363	480						
		fsw (kHz)	132	99	75						
4	20	Rsw (kΩ)	353	473							
		fsw (kHz)	102	76							

Note: Table 2 applies to circuit shown in Figure 2.

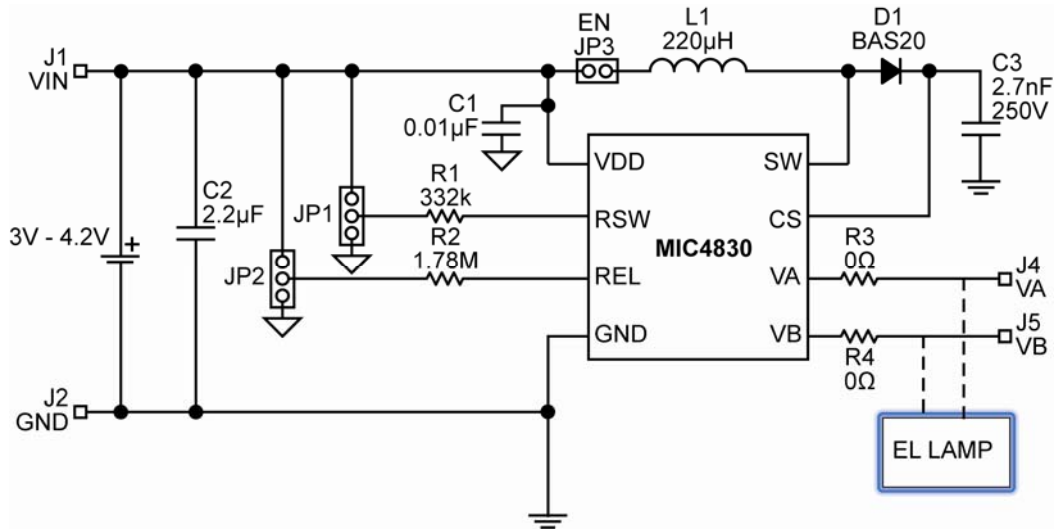

Figure 3. Evaluation Board Schematic

**Bill of Materials**

Item	Part Number	Manufacturer	Description	Qty
C1	C1608X7R1A103K	TDK	0.01µF Ceramic Capacitor, 10V, X7R, Size 0603	1
C2	C1608X5R0J225K	TDK	2.2µF Ceramic Capacitor, 6.3V, X5R, Size 0603	1
C3	C2012C0G2E2272J	TDK	0.0027µF Ceramic Capacitor, 250V, C0G, Size 0805	1
L1	LPF2810BT-221M(B)	ABCO	220µH, 110mA I <sub>SAT</sub> .	1
D1	BAS20-V-GS18	Vishay	200V/200mA Hi-Voltage Switching Diode	1
R1	CRCW06033323FKEYE3	Vishay	332kΩ, 1%, 1/16W, Size 0603	1
R2	CRCW06031784FKEYE3	Vishay	1.78MΩ, 1%, 1/16W, Size 0603	1
R3, R4	CRCW06030R00FKEYE3	Vishay	0Ω, 1%, 1/16W, Size 0603	2
U1	MIC4830	Micrel	Low Noise 180Vp-p EL Driver	1

**Notes:**

1. TDK: [www.tdk.com](http://www.tdk.com)
2. ABCO: [www.abco.com](http://www.abco.com)
3. Vishay: [www.vishay.com](http://www.vishay.com)
4. **Micrel, Inc.:** [www.micrel.com](http://www.micrel.com)

### Printed Circuit Board Layout (MSOP)

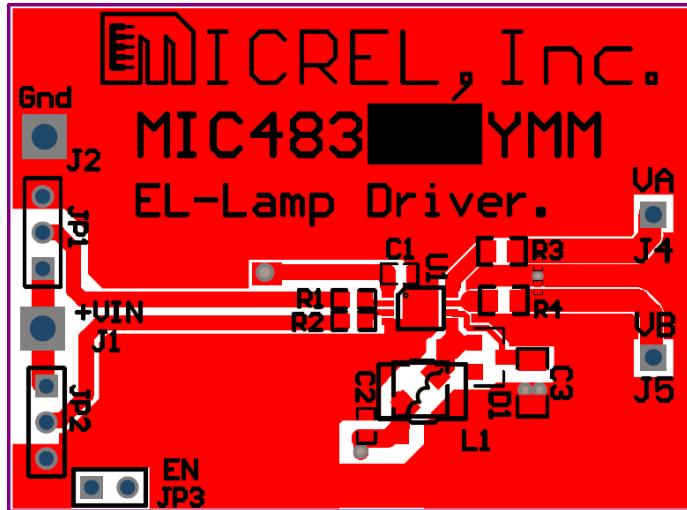

MSOP Top

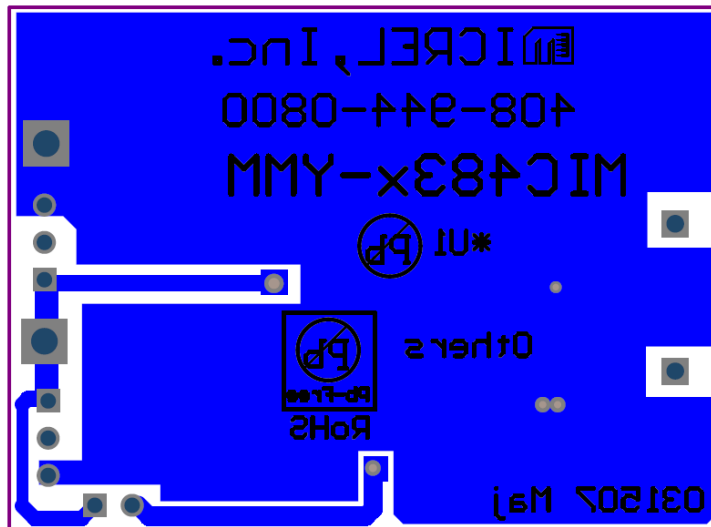

MSOP Bottom

### Printed Circuit Board Layout (MLF<sup>®</sup>)

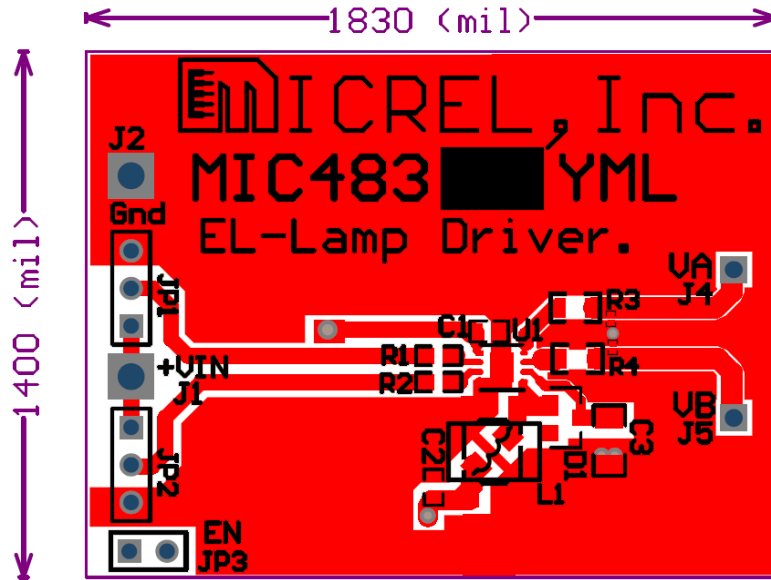

MLF<sup>®</sup> Top

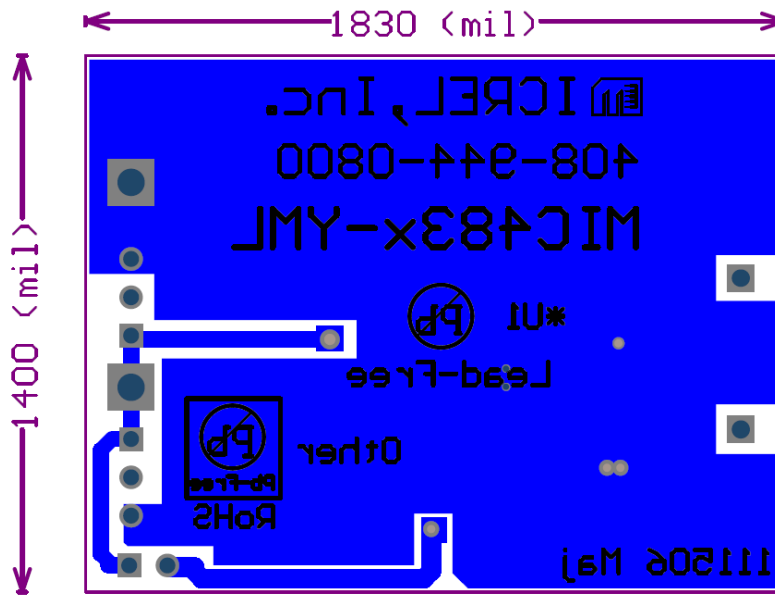

MLF<sup>®</sup> Bottom

---

**MICREL, INC. 2180 FORTUNE DRIVE SAN JOSE, CA 95131 USA**  
TEL +1 (408) 944-0800 FAX +1 (408) 474-1000 WEB <http://www.micrel.com>

The information furnished by Micrel in this data sheet is believed to be accurate and reliable. However, no responsibility is assumed by Micrel for its use. Micrel reserves the right to change circuitry and specifications at any time without notification to the customer.

Micrel Products are not designed or authorized for use as components in life support appliances, devices or systems where malfunction of a product can reasonably be expected to result in personal injury. Life support devices or systems are devices or systems that (a) are intended for surgical implant into the body or (b) support or sustain life, and whose failure to perform can be reasonably expected to result in a significant injury to the user. A Purchaser's use or sale of Micrel Products for use in life support appliances, devices or systems is a Purchaser's own risk and Purchaser agrees to fully indemnify Micrel for any damages resulting from such use or sale.

© 2007 Micrel, Incorporated.

## X-ON Electronics

Largest Supplier of Electrical and Electronic Components

*Click to view similar products for [LED Lighting Drivers](#) category:*

*Click to view products by [Microchip](#) manufacturer:*

Other Similar products are found below :

[LV5235V-MPB-H](#) [MB39C602PNF-G-JNEFE1](#) [MIC2871YMK-T5](#) [AL1676-10BS7-13](#) [AL1676-20AS7-13](#) [AP5726WUG-7](#) [MX877RTR](#)  
[ICL8201](#) [IS31BL3228B-UTLS2-TR](#) [IS31BL3506B-TTLS2-TR](#) [AL3157F-7](#) [AP5725FDCG-7](#) [AP5726FDCG-7](#) [LV52204MTTBG](#)  
[AP5725WUG-7](#) [STP4CMPQTR](#) [NCL30086BDR2G](#) [CAT4004BHU2-GT3](#) [LV52207AXA-VH](#) [AP1694AS-13](#) [TLE4242EJ](#) [AS3688](#)  
[IS31LT3172-GRLS4-TR](#) [TLD2311EL](#) [KTD2694EDQ-TR](#) [KTZ8864EJAA-TR](#) [IS32LT3174-GRLA3-TR](#) [ZXLD1374QESTTC](#) [MP2488DN-](#)  
[LF-Z](#) [NLM0010XTSA1](#) [AL1676-20BS7-13](#) [MPQ7220GF-AEC1-P](#) [MPQ4425BGJ-AEC1-P](#) [MPQ7220GF-AEC1-Z](#) [MPQ4425BGJ-AEC1-Z](#)  
[IS31FL3737B-QFLS4-TR](#) [IS31FL3239-QFLS4-TR](#) [KTD2058EUAC-TR](#) [KTD2037EWE-TR](#) [DIO5662ST6](#) [IS31BL3508A-TTLS2-TR](#)  
[MAX20052CATC/V+](#) [MAX25606AUP/V+](#) [BD6586MUV-E2](#) [BD9206EFV-E2](#) [BD9416FS-E2](#) [LYT4227E](#) [LYT6079C-TL](#) [MP3394SGF-P](#)  
[MP4689AGN-P](#)