

## High-Speed, High-Side MOSFET Driver with Charge Pump and Overcurrent Limit

### Features

- 12V to 36V Operation
- 550 ns Rise/Fall Time Driving 2000 pF
- TTL-Compatible Input with Internal Pull-Down Resistor
- Overcurrent Limit
- Gate-to-Source Protection
- Internal Charge Pump
- 100 kHz Operation Guaranteed Over Full Temperature and Operating Voltage Range
- Compatible with Current-Sensing MOSFETs
- Current-Source Drive Reduces EMI

### Applications

- Lamp Control
- Heater Control
- Motor Control
- Solenoid Switching
- Switch-Mode Power Supplies
- Circuit Breaker

### General Description

The MIC5021 high-side MOSFET driver is designed to operate at frequencies up to 100 kHz (5 kHz PWM for 2% to 100% duty cycle) and is an ideal choice for high speed applications such as motor control, SMPS (switch mode power supplies), and applications using IGBTs. The MIC5021 can also operate as a circuit breaker with or without automatic retry.

A rising or falling edge on the input results in a current source pulse or sink pulse on the gate output. This output current pulse can turn on a 2000 pF MOSFET in approximately 550 ns. The MIC5021 then supplies a limited current (<2 mA), if necessary, to maintain the output state.

An overcurrent comparator with a trip voltage of 50 mV makes the MIC5021 ideal for use with a current-sensing MOSFET. An external low value resistor may be used instead of a sensing MOSFET for more precise overcurrent control. An optional external capacitor placed from the C<sub>T</sub> pin to ground may be used to control the current shutdown duty cycle (dead time) from 20% to <1%. A duty cycle from 20% to about 75% is possible with an optional pull-up resistor from C<sub>T</sub> to V<sub>DD</sub>. Additional parts of the MIC502x family include the MIC5020 low-side driver and the MIC5022 half-bridge driver with a cross-conduction interlock. The MIC5021 is available in 8-pin SOIC and plastic DIP packages.

### Typical Application Circuit

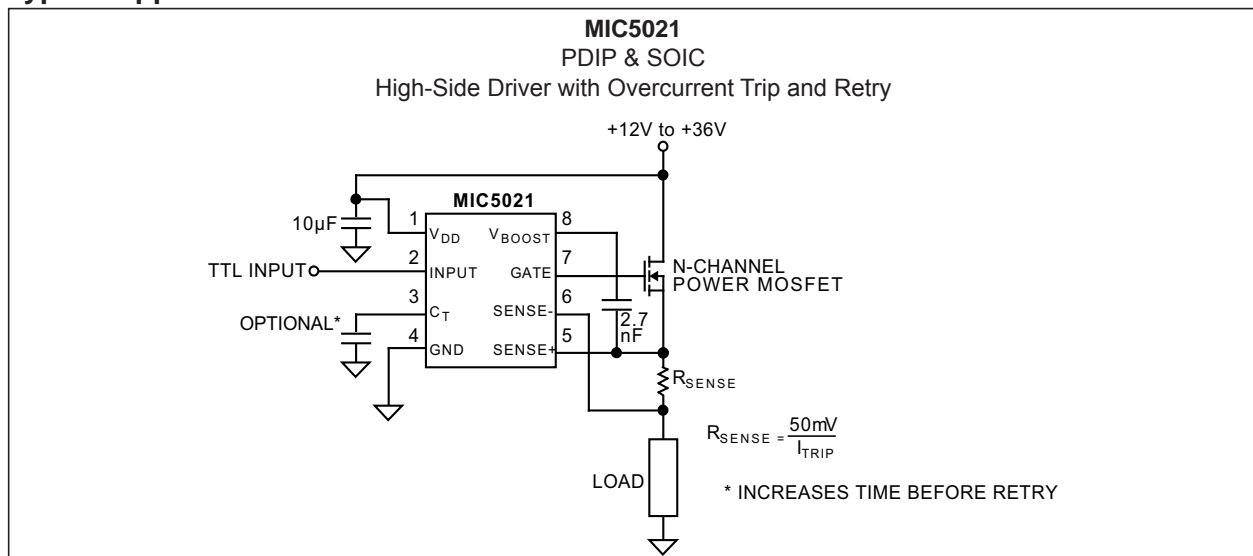

# MIC5021

## Package Types

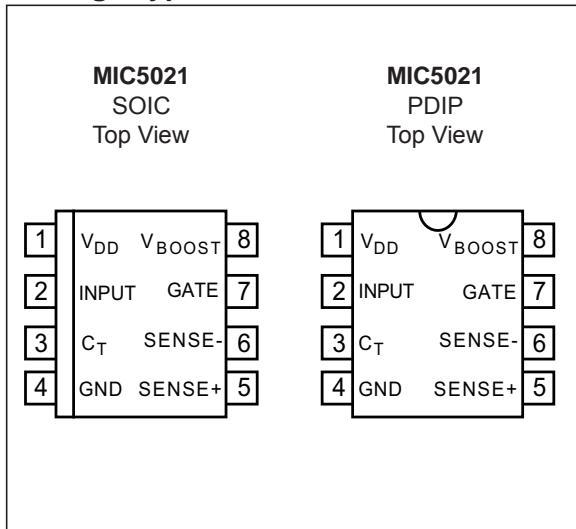

## Functional Block Diagram

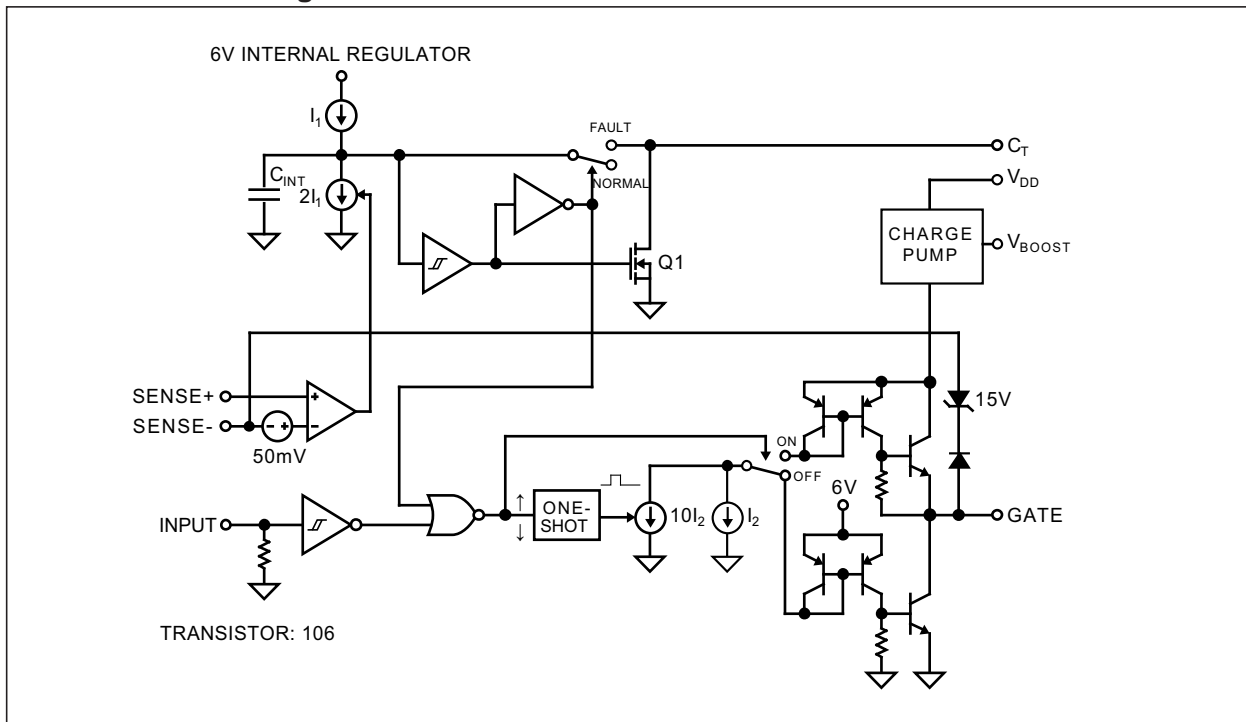

## 1.0 ELECTRICAL CHARACTERISTICS

### Absolute Maximum Ratings †

Supply Voltage, $V_{DD}$ .....	+40V
Input Voltage, $V_{IN}$ .....	-0.5V to +15V
Sense Differential Voltage.....	±6.5V
SENSE+ or SENSE- to GND.....	-0.5V to +36V
Timer Voltage.....	+5.5V
$V_{BOOST}$ Capacitor.....	0.01 $\mu$ F

### Operating Ratings

Supply Voltage, $V_{DD}$ .....	+12V to +36V
--------------------------------	--------------

† **Notice:** Stresses above those listed under “Absolute Maximum Ratings” may cause permanent damage to the device. This is a stress rating only and functional operation of the device at those or any other conditions above those indicated in the operational sections of this specification is not intended. Exposure to maximum rating conditions for extended periods may affect device reliability.

### DC CHARACTERISTICS

**Electrical Characteristics:** Unless otherwise indicated,  $T_A = +25^\circ\text{C}$ ,  $\text{GND} = 0\text{V}$ ,  $V_{DD} = 12\text{V}$ ,  $C_T = \text{OPEN}$ , Gate  $C_L = 1500\text{ pF}$  (IRF540 MOSFET).

Parameters	Sym.	Min.	Typ.	Max.	Units	Conditions
DC Supply Current	—	—	1.8	4	mA	$V_{DD} = 12\text{V}$ , Input = 0V
	—	—	2.5	6		$V_{DD} = 36\text{V}$ , Input = 0V
	—	—	1.7	4		$V_{DD} = 12\text{V}$ , Input = 5V
	—	—	2.5	6		$V_{DD} = 36\text{V}$ , Input = 5V
Input Threshold	—	0.8	1.4	2.0	V	—
Input Hysteresis	—	—	0.1	—	V	—
Input Pull-Down Current	—	10	20	40	$\mu$ A	Input = 5V
Current-Limit Threshold	—	30	50	70	mV	Note 1
Gate On Voltage	—	16	18	21	V	$V_{DD} = 12\text{V}$ (Note 2)
	—	46	50	52		$V_{DD} = 36\text{V}$ (Note 2)
Gate On-Time (Fixed)	$t_{G(\text{ON})}$	2	6	10	$\mu$ s	Sense Differential > 70 mV (Note 8)
Gate Off-Time (Adjustable)	$t_{G(\text{OFF})}$	10	20	50	$\mu$ s	Sense Differential > 70 mV, $C_T = 0\text{ pF}$ (Note 8)
Gate Turn-On Delay	$t_{\text{DLH}}$	—	500	1000	ns	Note 3
Gate Rise Time	$t_R$	—	400	500	ns	Note 4
Gate Turn-Off Delay	$t_{\text{DLH}}$	—	800	1500	ns	Note 5

**Note 1:** When using sense MOSFETs, it is recommended that  $R_{\text{SENSE}} < 50\Omega$ . Higher values may affect the sense MOSFET's current transfer ratio.

**2:** DC measurement.

**3:** Input switched from 0.8V (TTL low) to 2.0V (TTL high), time for gate transition from 0V to 2V.

**4:** Input switched from 0.8V (TTL low) to 2.0V (TTL high), time for gate transition from 2V to 17V.

**5:** Input switched from 2.0V (TTL high) to 0.8V (TTL low), time for gate transition from 20V (gate on voltage) to 17V.

**6:** Input switched from 2.0V (TTL high) to 0.8V (TTL low), time for gate transition from 17V to 2V.

**7:** Frequency where gate on voltage reduces to 17V with 50% input duty cycle.

**8:** Gate on time  $t_{G(\text{ON})}$  and  $t_{G(\text{OFF})}$  are not 100% production tested.

# MIC5021

## DC CHARACTERISTICS (CONTINUED)

**Electrical Characteristics:** Unless otherwise indicated,  $T_A = +25^\circ\text{C}$ ,  $\text{GND} = 0\text{V}$ ,  $V_{\text{DD}} = 12\text{V}$ ,  $C_T = \text{OPEN}$ , Gate  $C_L = 1500\text{ pF}$  (IRF540 MOSFET).

Parameters	Sym.	Min.	Typ.	Max.	Units	Conditions
Gate Fall Time	$t_F$	—	400	500	ns	Note 6
Max. Operating Frequency	$f_{\text{MAX}}$	100	150	—	kHz	Note 7

**Note 1:** When using sense MOSFETs, it is recommended that  $R_{\text{SENSE}} < 50\Omega$ . Higher values may affect the sense MOSFET's current transfer ratio.

**2:** DC measurement.

**3:** Input switched from 0.8V (TTL low) to 2.0V (TTL high), time for gate transition from 0V to 2V.

**4:** Input switched from 0.8V (TTL low) to 2.0V (TTL high), time for gate transition from 2V to 17V.

**5:** Input switched from 2.0V (TTL high) to 0.8V (TTL low), time for gate transition from 20V (gate on voltage) to 17V.

**6:** Input switched from 2.0V (TTL high) to 0.8V (TTL low), time for gate transition from 17V to 2V.

**7:** Frequency where gate on voltage reduces to 17V with 50% input duty cycle.

**8:** Gate on time  $t_{\text{G(ON)}}$  and  $t_{\text{G(OFF)}}$  are not 100% production tested.

## TEMPERATURE SPECIFICATIONS (Note 1)

Parameters	Sym.	Min.	Typ.	Max.	Units	Conditions
<b>Junction Thermal Resistances</b>						
Thermal Resistance, PDIP-8Ld	$\theta_{JA}$	-40	—	85	°C	Maximum Ambient Temperature
Thermal Resistance, SOIC-8Ld	$\theta_{JA}$	-40	—	85	°C	Maximum Ambient Temperature

**Note 1:** The maximum allowable power dissipation is a function of ambient temperature, the maximum allowable junction temperature and the thermal resistance from junction to air (i.e.,  $T_A$ ,  $T_J$ ,  $\theta_{JA}$ ). Exceeding the maximum allowable power dissipation will cause the device operating junction temperature to exceed the maximum rating. Sustained junction temperatures above the maximum rating can impact the device reliability.

# MIC5021

## 2.0 TIMING DIAGRAMS

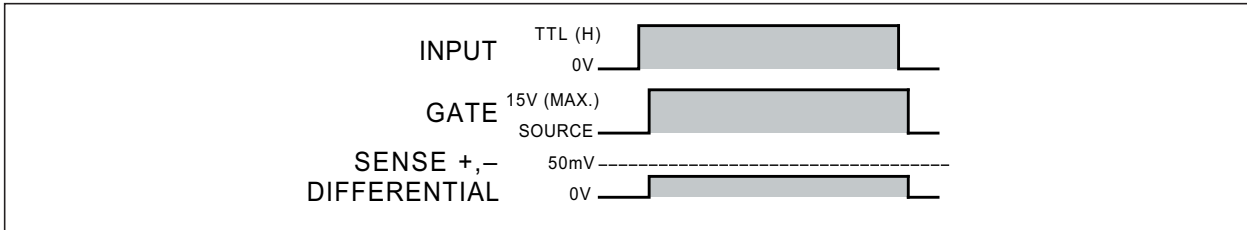

**FIGURE 2-1:** Normal operation.

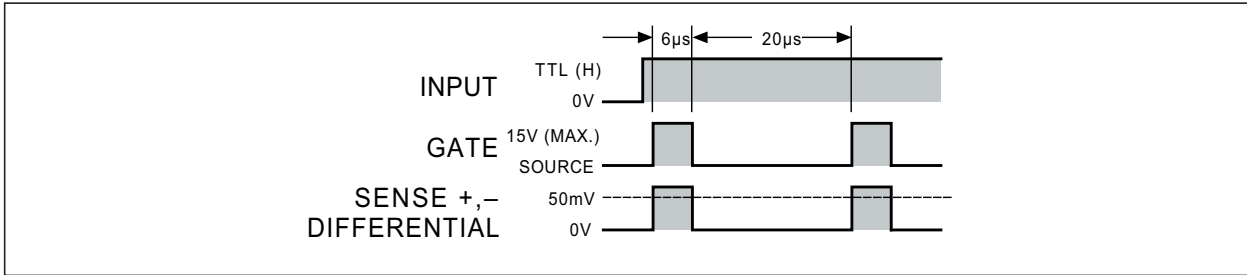

**FIGURE 2-2:** Fault Operation,  $C_T = \text{Open}$ .

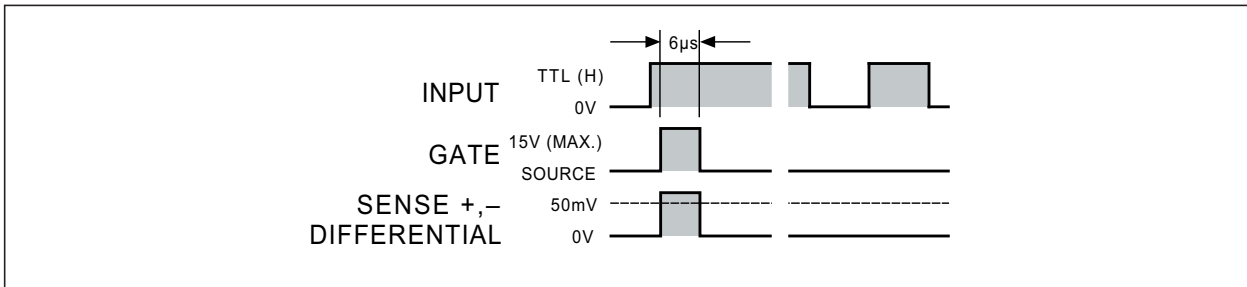

**FIGURE 2-3:** Fault Condition,  $C_T = \text{Grounded}$ .

## 3.0 TYPICAL PERFORMANCE CURVES

**Note:** The graphs and tables provided following this note are a statistical summary based on a limited number of samples and are provided for informational purposes only. The performance characteristics listed herein are not tested or guaranteed. In some graphs or tables, the data presented may be outside the specified operating range (e.g., outside specified power supply range) and therefore outside the warranted range.

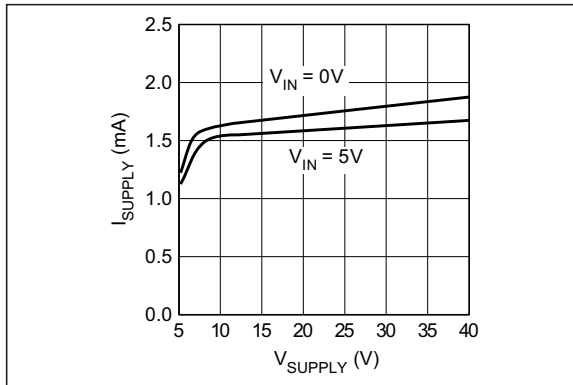

**FIGURE 3-1:** Supply Current vs. Supply Voltage.

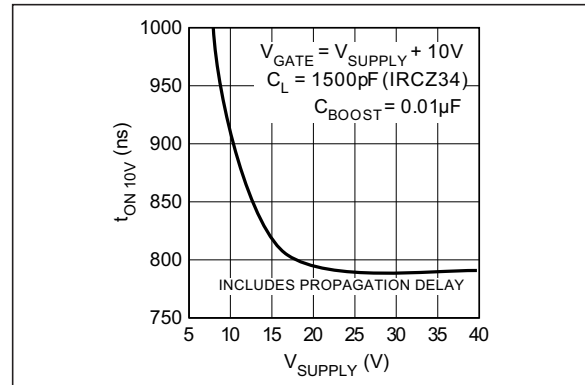

**FIGURE 3-4:** Gate Turn-On Delay vs. Supply Voltage.

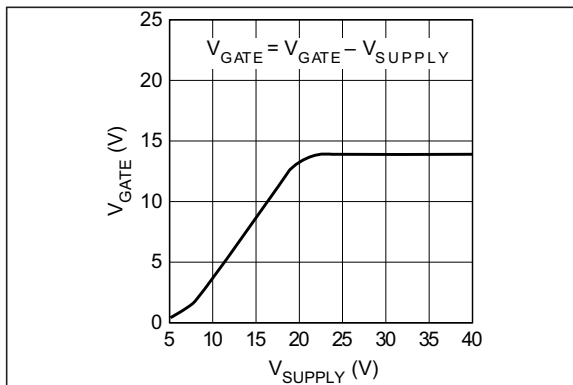

**FIGURE 3-2:** Gate Voltage Change vs. Supply Voltage.

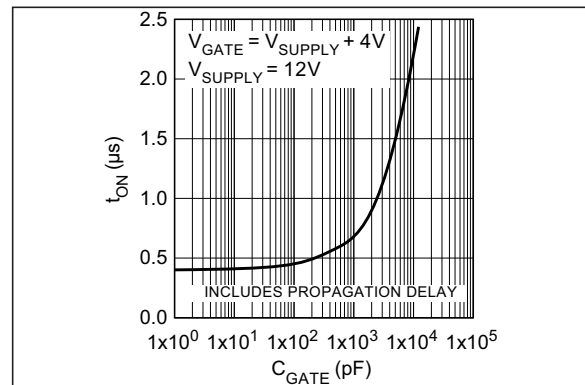

**FIGURE 3-5:** Gate Turn-On Delay vs. Gate Capacitance.

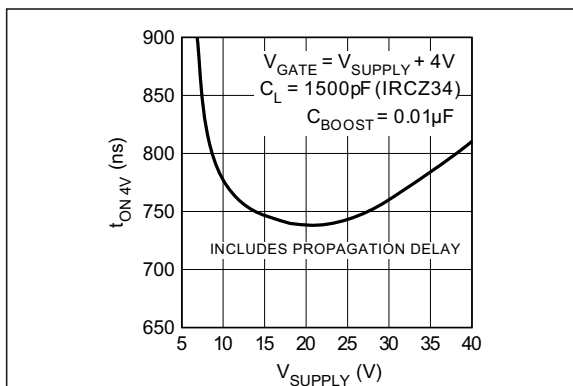

**FIGURE 3-3:** Gate Turn-On Delay vs. Supply Voltage.

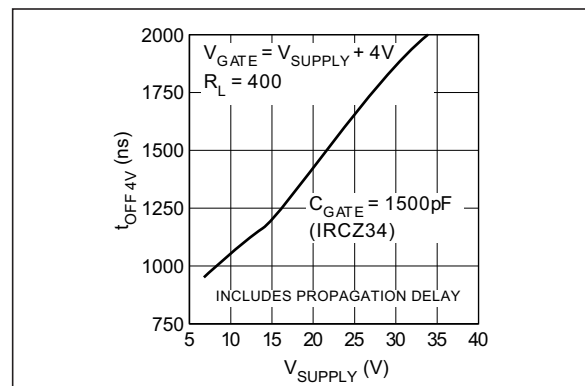

**FIGURE 3-6:** Gate Turn-Off Delay vs. Supply Voltage.

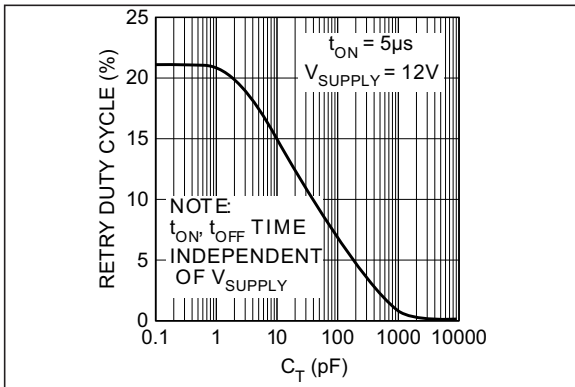

**FIGURE 3-7:** Overcurrent Retry Duty Cycle vs. Timing Capacitance.

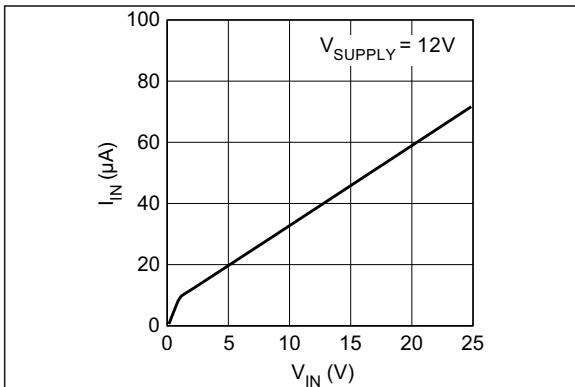

**FIGURE 3-8:** Input Current vs. Input Voltage.

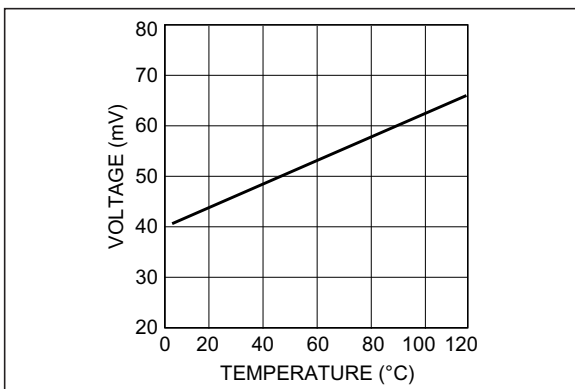

**FIGURE 3-9:** Sense Threshold vs. Temperature.



## 4.0 PIN DESCRIPTIONS

The descriptions of the pins are listed in [Table 4-1](#).

**TABLE 4-1: PIN FUNCTION TABLE**

Pin Number	Pin Name	Description
1	V <sub>DD</sub>	Supply (+12V to 36V). Decouple with ≥ 10 μF capacitor.
2	INPUT	TTL-Compatible Input. Logic high turns the external MOSFET on. An internal pull-down returns an open pin logic low.
3	CT	Retry Timing Capacitor. Controls the off time (t <sub>G(OFF)</sub> ) of the overcurrent retry cycle (duty cycle adjustment): Open = Approximately 20% duty cycle. Capacitor-to-Ground = Approximately 20% to <1% duty cycle. Pull-Up Resistor = Approximately 20% to approximately 75% duty cycle. Ground = Maintained shutdown upon overcurrent condition.
4	GND	Circuit Ground.
5	SENSE+	Current-Sense Comparator (+) Input. Connect to high side of sense resistor or current sensing MOSFET sense lead. A built-in offset in conjunction with RSENSE sets the load overcurrent trip point.
6	SENSE-	Current-Sense Comparator (-) Input. Connect to the low side of the sense resistor (usually the high side of the load).
7	GATE	Gate Drive. Drives the gate of an external power MOSFET. Also limits V <sub>GS</sub> to 15V maximum to prevent gate-to-source damage. Will sink-and-source current.
8	V <sub>BOOST</sub>	Charge Pump Boost Capacitor. A bootstrap capacitor from V <sub>BOOST</sub> to the FET source pin supplies charge to quickly enhance the gate output during turn-on.

# MIC5021

---

## 5.0 FUNCTIONAL DESCRIPTION

Refer to the MIC5021 [Functional Block Diagram](#).

### 5.1 Input

A signal greater than 1.4V (nominal) applied to the MIC5021 INPUT causes gate enhancement on an external MOSFET turning the MOSFET on.

An internal pull-down resistor ensures that an open input remains low, keeping the external MOSFET turned off.

### 5.2 Gate Output

Rapid rise and fall times on the gate output are possible because each input state change triggers a one-shot which activates a high-value current sink ( $10I_2$ ) for a short time. This draws a high current through a current mirror circuit causing the output transistors to quickly charge or discharge the external MOSFET's gate.

A second current sink continuously draws the lower value of current used to maintain the gate voltage for the selected state.

An internal charge pump utilizes an external "boost" capacitor connected between  $V_{BOOST}$  and the source of the external MOSFET (Refer to the [Typical Application Circuit](#)). The boost capacitor stores charge when the MOSFET is off. As the MOSFET turns on, its source to ground voltage increases and is added to the voltage across the capacitor, raising the  $V_{BOOST}$  pin voltage. The boost capacitor charge is directed through the gate pin to quickly charge the MOSFET's gate to 16V maximum above  $V_{DD}$ . The internal charge pump maintains the gate voltage.

An internal Zener diode protects the external MOSFET by limiting the gate to source voltage.

### 5.3 SENSE Inputs

The MIC5021's 50 mV (nominal) trip voltage is created by internal current sources that force approximately 5  $\mu$ A out of SENSE+ and approximately 15  $\mu$ A (at trip) out of SENSE-. When SENSE- is 50mV or more below SENSE+, SENSE- steals base current from an internal drive transistor shutting off the external MOSFET.

### 5.4 Overcurrent Limiting

Current source I1 charges  $C_{INT}$  upon power up. An optional external capacitor connected to  $C_T$  is kept discharged through a MOSFET Q1.

A fault condition (>50 mV from SENSE+ to SENSE-) causes the overcurrent comparator to enable current sink  $2I_1$  which overcomes current source I1 to discharge  $C_{INT}$  in a short time. When  $C_{INT}$  is discharged, the input is disabled, which turns off the gate output, and  $C_{INT}$  and  $C_T$  are ready to be charged.

When the gate output turns the MOSFET off, the overcurrent signal is removed from the sense inputs which deactivates current sink  $2I_1$ . This allows  $C_{INT}$  and the optional capacitor connected to  $C_T$  to recharge. A Schmitt trigger delays the retry while the capacitor(s) recharge. Retry delay is increased by connecting a capacitor to  $C_T$  (optional).

The retry cycle will continue until the fault is removed or the input is changed to TTL low.

If  $C_T$  is connected to ground, the circuit will not retry upon a fault condition.

## 6.0 APPLICATION INFORMATION

The MIC5021 MOSFET driver is intended for high-side switching applications where overcurrent limiting and high speed are required. The MIC5021 can control MOSFETs that switch voltages up to 36V.

### 6.1 High-Side Switch Circuit Advantages

High-side switching allows more of the load related components and wiring to remain near ground potential when compared to low-side switching. This reduces the chances of short-to-ground accidents or failures.

### 6.2 Speed Advantage

The MIC5021 is about two orders of magnitude faster than the low cost MIC5014 making it suitable for high-frequency high-efficiency circuit operation in PWM (pulse width modulation) designs used for motor control, SMPS (switch-mode power supply) and heating element control.

Switched loads (on/off) benefit from the MIC5021's fast switching times by allowing use of MOSFETs with smaller safe operating areas. Larger MOSFETs are often required when using slower drivers.

### 6.3 Supply Voltage

The MIC5021's supply input ( $V_{DD}$ ) is rated up to 36V. The supply voltage must be equal to or greater than the voltage applied to the drain of the external N-channel MOSFET.

A 16V minimum supply is recommended to produce continuous on-state, gate drive voltage for standard MOSFETs (10V nominal gate enhancement).

When the driver is powered from a 12V to 16V supply, a logic-level MOSFET is recommended (5V nominal gate enhancement).

PWM operation may produce satisfactory gate enhancement at lower supply voltages. This occurs when fast switching repetition makes the boost capacitor a more significant voltage supply than the internal charge pump.

### 6.4 Logic-Level MOSFET Precautions

Logic-level MOSFETs have lower maximum gate-to-source voltage ratings (typically  $\pm 10V$ ) than standard MOSFETs (typically  $\pm 20V$ ). When an external MOSFET is turned on, the doubling effect of the boost capacitor can cause the gate-to-source voltage to momentarily exceed 10V. Internal zener diodes clamp this voltage to 16V maximum which is too high for logic-level MOSFETs. To protect logic-level MOSFETs, connect a zener diode ( $5V \leq V_{ZENER} < 10V$ ) from gate to source.

### 6.5 Overcurrent Limiting

A 50 mV comparator is provided for current sensing. The low level trip point minimizes  $I_2R$  losses when a power resistor is used for current sensing.

The adjustable retry feature can be used to handle loads with high initial currents, such as lamps or heating elements, and can be adjusted from the  $C_T$  connection.

$C_T$  to ground maintains gate drive shutdown following an overcurrent condition.

$C_T$  open, or a capacitor to ground, causes automatic retry. The default duty cycle ( $C_T$  open) is approximately 20%. Refer to the [Electrical Characteristics](#) when selecting a capacitor for reduced duty cycle.

$C_T$  through a pull-up resistor to  $V_{DD}$  increases the duty cycle. Increasing the duty cycle increases the power dissipation in the load and MOSFET under a fault condition. Circuits may become unstable at a duty cycle of about 75% or higher, depending on conditions. Caution: The MIC5021 may be damaged if the voltage applied to  $C_T$  exceeds the absolute maximum voltage rating.

### 6.6 Boost Capacitor Selection

The boost capacitor value will vary depending on the supply voltage range.

A 0.01  $\mu F$  boost capacitor is recommended for best performance in the 12V to 20V range. (See [Figure 6-1](#).) Larger capacitors may damage the MIC5021.

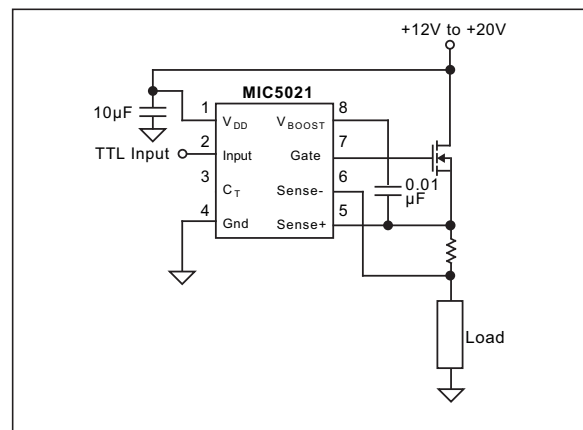

**FIGURE 6-1:** 12V to 20V Configuration.

If the full 12V to 36V voltage range is required, the boost capacitor value must be reduced to 2.7 nF ([Figure 6-2](#)). The recommended configuration for the 20V to 36V range is to place the capacitor is placed between  $V_{DD}$  and  $V_{BOOST}$  as shown in [Figure 6-3](#).

# MIC5021

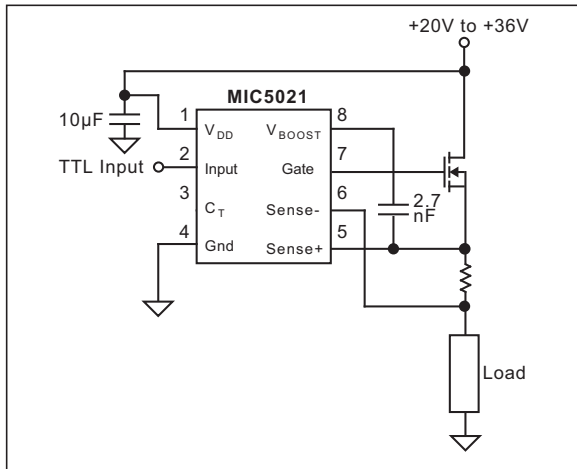

**FIGURE 6-2:** 12V to 36V Configuration.

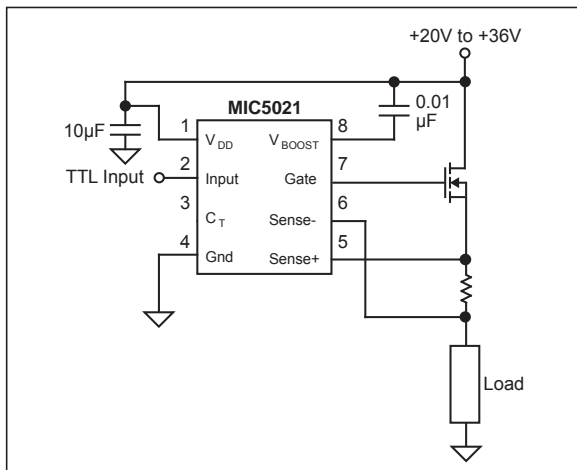

**FIGURE 6-3:** Preferred 20V to 36V Configuration.

Do not use both boost capacitors between  $V_{BOOST}$  and the MOSFET source and  $V_{BOOST}$  and  $V_{DD}$  at the same time.

## 6.7 Current-Sense Resistors

Lead length can be significant when using low value (<1Ω) resistors for current sensing. Errors caused by lead length can be avoided by using four-terminal current-sensing resistors. Four-terminal resistors are available from several manufacturers.

## 6.8 Circuits without Current Sensing

Current sensing may be omitted by connecting the SENSE+ and SENSE- pins to the source of the MOSFET or to the supply. Connecting the sense pins to the supply is preferred for inductive loads. Do not connect the sense pins to ground.

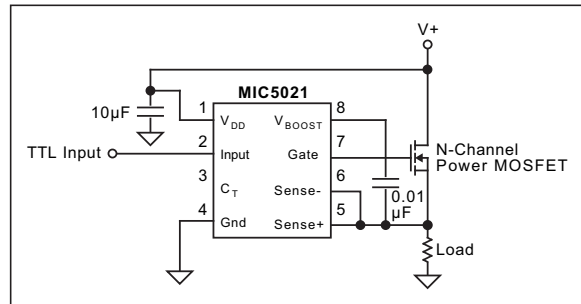

**FIGURE 6-4:** Connecting Sense to Source.

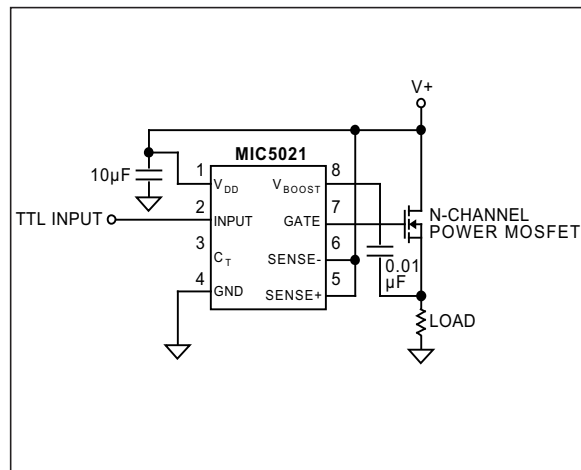
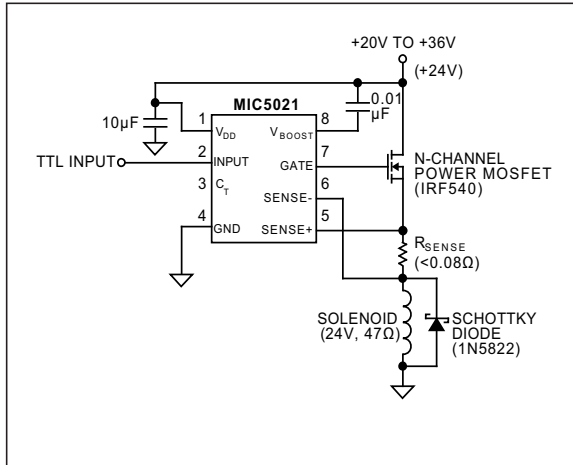

**FIGURE 6-5:** Connecting Sense to Supply.

## 6.9 Inductive Load Precautions

Circuits controlling inductive loads, such as solenoids (Figure 6-6) and motors, require precautions when controlled by the MIC5021. Wire wound resistors, which are sometimes used to simulate other loads, can also show significant inductive properties.

An inductive load releases stored energy when its current flow is interrupted (when the MOSFET is switched off). The voltage across the inductor reverses and the inductor attempts to force current flow. Since the circuit appears open (the MOSFET appears as a very high resistance) a very large negative voltage occurs across the inductor.



**FIGURE 6-6:** Solenoid Driver with Current Sensing.

## 6.9.1 LIMITING INDUCTIVE SPIKES

The voltage across the inductor can be limited by connecting a Schottky diode across the load. The diode is forward biased only when the load is switched off. The Schottky diode clamps negative transients to a few volts. This protects the MOSFET from drain-to-source breakdown and prevents the transient from damaging the charge pump by way of the boost capacitor (see [Sense Pin Considerations](#)).

The diode should have a peak forward current rating greater than the load current. This is because the current through the diode is the same as the load current at the instant the MOSFET is turned off.

## 6.9.2 SENSE PIN CONSIDERATIONS

The sense pins of the MIC5021 are sensitive to negative voltages. Forcing the sense pins much below  $-0.5\text{V}$  effectively reverses the supply voltage on portions of the driver resulting in unpredictable operation or damage.

Figure 6-7 shows current flowing out of the sense leads of an MIC5021 during a negative transient (inductive kick). Internal Schottky diodes attempt to limit the negative transient by maintaining a low forward drop.

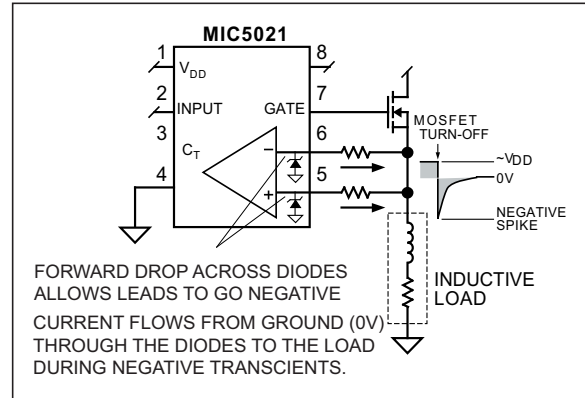

**FIGURE 6-7:** Inductive Load Turn-Off.

Although the internal Schottky diodes can protect the driver in low-current resistive applications, they are inadequate for inductive loads or the lead inductance in high-current resistive loads. Because of their small size, the diodes' forward voltage drop quickly exceeds  $0.5\text{V}$  as current increases.

## 6.9.3 EXTERNAL PROTECTION

Resistors placed in series with each SENSE connection limit the current drawn from the internal Schottky diodes during a negative transient. This minimizes the forward drop across the diodes.

During normal operation, sensing current from the sense pins is unequal ( $5\ \mu\text{A}$  and  $15\ \mu\text{A}$ ). The internal Schottky diodes are reverse-biased and have no effect. To avoid skewing the trip voltage, the current limiting resistors must drop equal voltages at the trip point currents (see [Figure 6-8](#)). To minimize resistor tolerance error, use a voltage drop lower than the trip voltage of  $50\ \text{mV}$ .  $5\ \text{mV}$  is suggested.

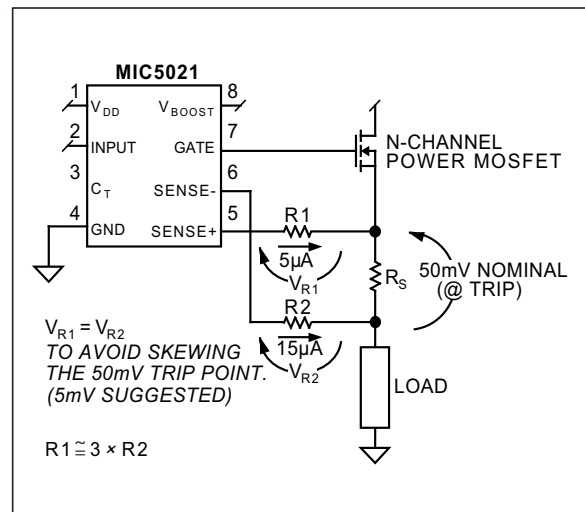

**FIGURE 6-8:** Resistor Voltage Drop.

# MIC5021

External Schottky diodes are also recommended (see D2 and D3 in Figure 6-9). The external diodes clamp negative transients better than the internal diodes because their larger size minimizes the forward voltage drop at higher currents.

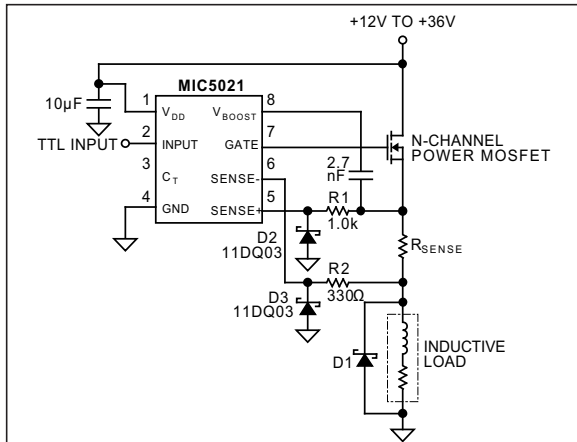

**FIGURE 6-9:** Protection from Inductive Kick.

## 6.9.4 HIGH-SIDE SENSING

Sensing the current on the high side of the MOSFET isolates the sense pins from the inductive spike.

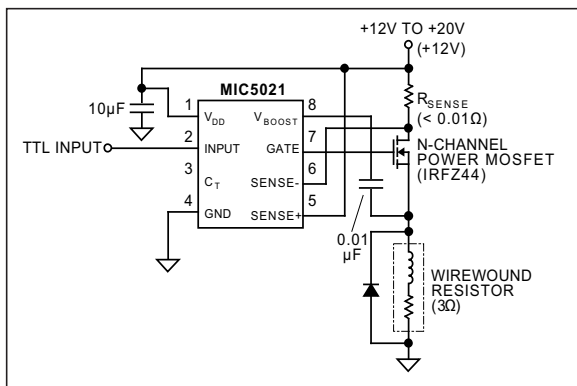

**FIGURE 6-10:** High-Side Sensing.

## 6.10 Lamp Driver Application

Incandescent lamps have a high inrush current (low resistance) when turned on. The MIC5021 can perform a “soft start” by pulsing the MOSFET (overcurrent condition) until the filament is warm and its current decreases (resistance increases). The sense resistor value is selected so the voltage drop across the sense resistor decreases below the sense threshold (50 mV) as the filament becomes warm. The FET is no longer pulsed and the lamp turns completely on.

A lamp may not fully turn on if the filament does not heat up adequately. Changing the duty cycle, sense resistor, or both to match the filament characteristics can correct the problem.

Soft start can be demonstrated using a #1157 dual filament automotive lamp. The value of  $R_S$  shown in Figure 6-11 allows for soft start of the higher-resistance filament (measures approx. 2.1Ω cold or 21Ω hot).

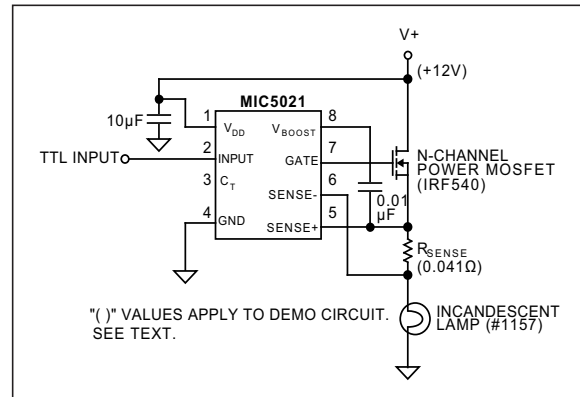

**FIGURE 6-11:** Lamp Driver with Current Sensing.

## 6.11 Remote Overcurrent Limiting Reset

In circuit breaker applications where the MIC5021 maintains an off condition after an overcurrent condition is sensed, the  $C_T$  pin can be used to reset the MIC5021.

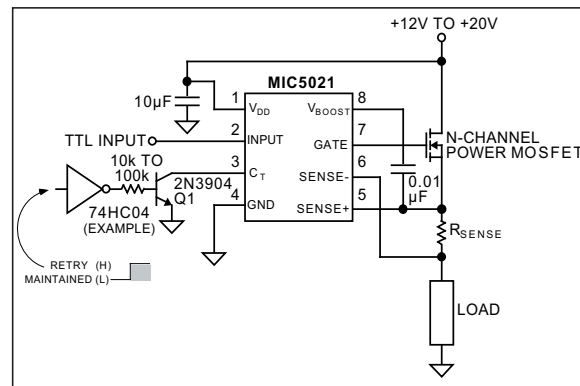
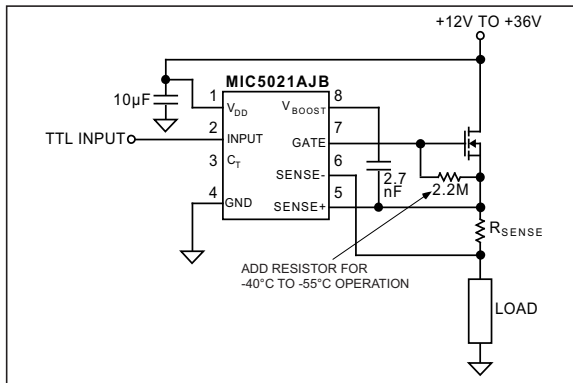

**FIGURE 6-12:** Remote Control Circuit.

Switching Q1 on pulls  $C_T$  low which keeps the MIC5021 gate output off when an overcurrent is sensed. Switching Q1 off causes  $C_T$  to appear open. The MIC5021 retries in about 20  $\mu$ s and continues to retry until the overcurrent condition is removed.

For demonstration purposes, a 680Ω load resistor and 3Ω sense resistor will produce an overcurrent condition when the load’s supply ( $V_+$ ) is approximately 12V or greater.

The gate-to-source configuration (refer to [Figure 6-13](#)) is appropriate for resistive and inductive loads. This also causes the smallest decrease in gate output voltage.



**FIGURE 6-13:** Gate-to-Source Pull-Down.

The gate-to-ground configuration (refer to [Figure 6-14](#)) is appropriate for resistive, inductive, or capacitive loads. This configuration will decrease the gate output voltage slightly more than the circuit shown in [Figure 6-13](#).

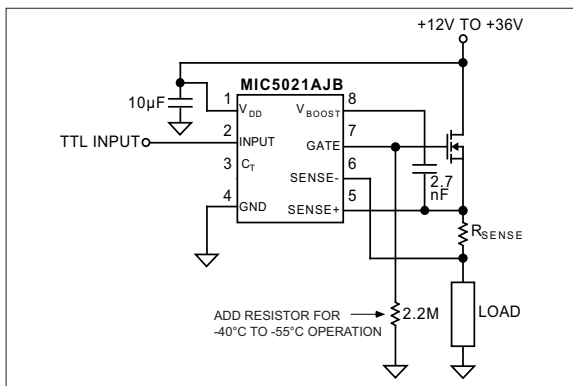
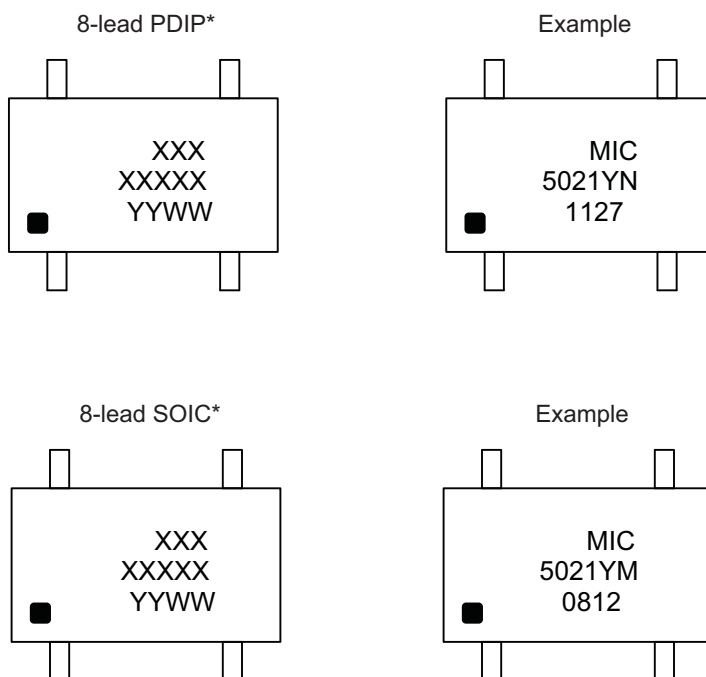

**FIGURE 6-14:** Gate-to-Ground Pull-Down.

# MIC5021

## 7.0 PACKAGING INFORMATION

### 7.1 Package Marking Information



<b>Legend:</b>	XX...X	Product code or customer-specific information
	Y	Year code (last digit of calendar year)
	YY	Year code (last 2 digits of calendar year)
	WW	Week code (week of January 1 is week '01')
	NNN	Alphanumeric traceability code
	(e3)	Pb-free JEDEC® designator for Matte Tin (Sn)
	*	This package is Pb-free. The Pb-free JEDEC designator (e3) can be found on the outer packaging for this package.
	•, ▲, ▼	Pin one index is identified by a dot, delta up, or delta down (triangle mark).
<b>Note:</b>	In the event the full Microchip part number cannot be marked on one line, it will be carried over to the next line, thus limiting the number of available characters for customer-specific information. Package may or may not include the corporate logo.	
	Underbar (¯) and/or Overbar (¯) symbol may not be to scale.	



## 8-Lead PDIP Package Outline & Recommended Land Pattern

**TITLE**

8 LEAD PDIP PACKAGE OUTLINE & RECOMMENDED LAND PATTERN

<b>DRAWING #</b>	PDIP-8LD-PL-1	<b>UNIT</b>	INCH
<b>Lead Frame</b>	Copper	<b>Lead Finish</b>	Matte Tin

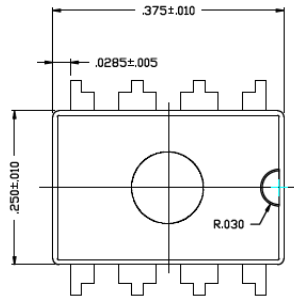

TOP VIEW

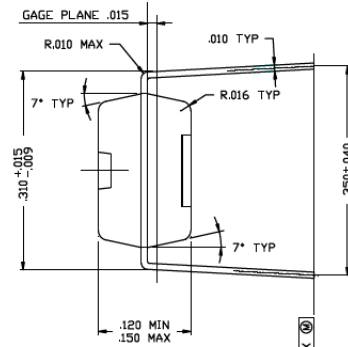

END VIEW

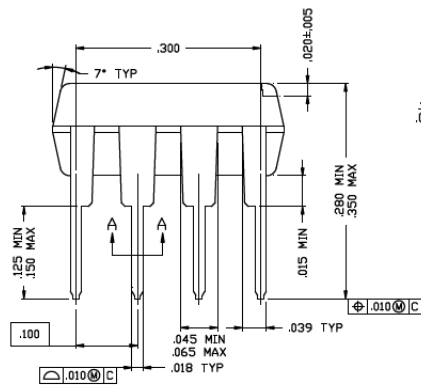

SIDE VIEW

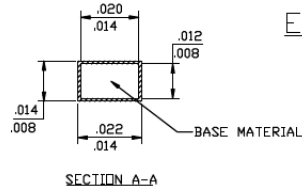

SECTION A-A

Note: For the most current package drawings, please see the Microchip Packaging Specification located at <http://www.microchip.com/packaging>.

# MIC5021

## 8-Lead SOICN Package Outline & Recommended Land Pattern

**TITLE**

8 LEAD SOICN PACKAGE OUTLINE & RECOMMENDED LAND PATTERN

DRAWING #	SOICN-8LD-PL-1	UNIT	INCH [MM]
-----------	----------------	------	-----------

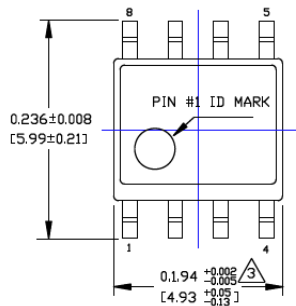

TOP VIEW

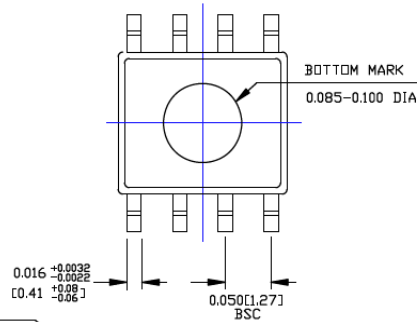

BOTTOM VIEW

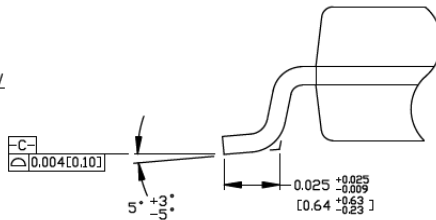

DETAIL "A"

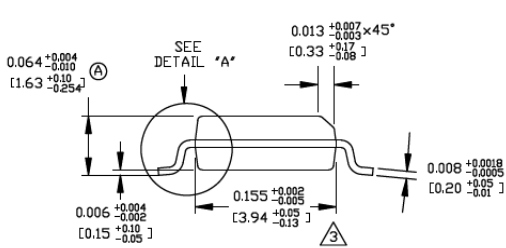

END VIEW

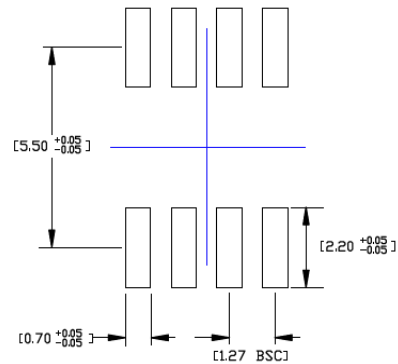

RECOMMENDED LAND PATTERN

**NOTES:**

1. DIMENSIONS ARE IN INCHES[MM].
2. CONTROLLING DIMENSION: INCHES.
3. DIMENSION DOES NOT INCLUDE MOLD FLASH OR PROTRUSIONS, EITHER OF WHICH SHALL NOT EXCEED 0.010[0.25] PER SIDE.

Note: For the most current package drawings, please see the Microchip Packaging Specification located at <http://www.microchip.com/packaging>.

## APPENDIX A: REVISION HISTORY

### Revision A (December 2016)

- Converted Micrel document MIC5021 to Microchip data sheet template DS20005677A.
- Minor grammatical text changes throughout.

# MIC5021

---

NOTES:

## PRODUCT IDENTIFICATION SYSTEM

To order or obtain information, e.g., on pricing or delivery, contact your local Microchip representative or sales office.

<u>PART NO.</u>		<u>X</u>	<u>XX</u>
Device	Temperature Range	Package	
<b>Device:</b>	MIC5021:	High-Speed, High-Side MOSFET Driver with Charge Pump and Overcurrent Limit	
<b>Temperature Range:</b>	Y	=	-40°C to +85°C (RoHS Compliant)
<b>Packages:</b>	M	=	8-Pin SOIC
	N	=	8-Pin Plastic DIP

<b>Examples:</b>	
a) MIC5021YM:	High-Speed, High-Side MOSFET Driver with Charge Pump and Overcurrent Limit, -40°C to +85°C (RoHS Compliant), 8LD SOIC
b) MIC5021YN:	High-Speed, High-Side MOSFET Driver with Charge Pump and Overcurrent Limit, -40°C to +85°C (RoHS Compliant), 8LD Plastic DIP

**Note 1:** Tape and Reel identifier only appears in the catalog part number description. This identifier is used for ordering purposes and is not printed on the device package. Check with your Microchip Sales Office for package availability with the Tape and Reel option.

# MIC5021

---

NOTES:

---

**Note the following details of the code protection feature on Microchip devices:**

- Microchip products meet the specification contained in their particular Microchip Data Sheet.
- Microchip believes that its family of products is one of the most secure families of its kind on the market today, when used in the intended manner and under normal conditions.
- There are dishonest and possibly illegal methods used to breach the code protection feature. All of these methods, to our knowledge, require using the Microchip products in a manner outside the operating specifications contained in Microchip's Data Sheets. Most likely, the person doing so is engaged in theft of intellectual property.
- Microchip is willing to work with the customer who is concerned about the integrity of their code.
- Neither Microchip nor any other semiconductor manufacturer can guarantee the security of their code. Code protection does not mean that we are guaranteeing the product as “unbreakable.”

Code protection is constantly evolving. We at Microchip are committed to continuously improving the code protection features of our products. Attempts to break Microchip's code protection feature may be a violation of the Digital Millennium Copyright Act. If such acts allow unauthorized access to your software or other copyrighted work, you may have a right to sue for relief under that Act.

---

Information contained in this publication regarding device applications and the like is provided only for your convenience and may be superseded by updates. It is your responsibility to ensure that your application meets with your specifications. MICROCHIP MAKES NO REPRESENTATIONS OR WARRANTIES OF ANY KIND WHETHER EXPRESS OR IMPLIED, WRITTEN OR ORAL, STATUTORY OR OTHERWISE, RELATED TO THE INFORMATION, INCLUDING BUT NOT LIMITED TO ITS CONDITION, QUALITY, PERFORMANCE, MERCHANTABILITY OR FITNESS FOR PURPOSE. Microchip disclaims all liability arising from this information and its use. Use of Microchip devices in life support and/or safety applications is entirely at the buyer's risk, and the buyer agrees to defend, indemnify and hold harmless Microchip from any and all damages, claims, suits, or expenses resulting from such use. No licenses are conveyed, implicitly or otherwise, under any Microchip intellectual property rights unless otherwise stated.

*Microchip received ISO/TS-16949:2009 certification for its worldwide headquarters, design and wafer fabrication facilities in Chandler and Tempe, Arizona; Gresham, Oregon and design centers in California and India. The Company's quality system processes and procedures are for its PIC® MCUs and dsPIC® DSCs, KEELoQ® code hopping devices, Serial EEPROMs, microperipherals, nonvolatile memory and analog products. In addition, Microchip's quality system for the design and manufacture of development systems is ISO 9001:2000 certified.*

**QUALITY MANAGEMENT SYSTEM  
CERTIFIED BY DNV  
= ISO/TS 16949 =**

### Trademarks

The Microchip name and logo, the Microchip logo, AnyRate, AVR, AVR logo, AVR Freaks, BeaconThings, BitCloud, CryptoMemory, CryptoRF, dsPIC, FlashFlex, flexPWR, Helder, JukeBlox, KEELoQ, KEELoQ logo, Klear, LANCheck, LINK MD, maXStylus, maXTouch, MediaLB, megaAVR, MOST, MOST logo, MPLAB, OptoLyzer, PIC, picoPower, PICSTART, PIC32 logo, Prochip Designer, QTouch, RightTouch, SAM-BA, SpyNIC, SST, SST Logo, SuperFlash, tinyAVR, UNI/O, and XMEGA are registered trademarks of Microchip Technology Incorporated in the U.S.A. and other countries.

ClockWorks, The Embedded Control Solutions Company, EtherSynch, Hyper Speed Control, HyperLight Load, IntelliMOS, mTouch, Precision Edge, and Quiet-Wire are registered trademarks of Microchip Technology Incorporated in the U.S.A.

Adjacent Key Suppression, AKS, Analog-for-the-Digital Age, Any Capacitor, AnyIn, AnyOut, BodyCom, chipKIT, chipKIT logo, CodeGuard, CryptoAuthentication, CryptoCompanion, CryptoController, dsPICDEM, dsPICDEM.net, Dynamic Average Matching, DAM, ECAN, EtherGREEN, In-Circuit Serial Programming, ICSP, Inter-Chip Connectivity, JitterBlocker, KlearNet, KlearNet logo, Mindi, MiWi, motorBench, MPASM, MPF, MPLAB Certified logo, MPLIB, MPLINK, MultiTRAK, NetDetach, Omniscient Code Generation, PICDEM, PICDEM.net, PICKit, PICTail, PureSilicon, QMatrix, RightTouch logo, REAL ICE, Ripple Blocker, SAM-ICE, Serial Quad I/O, SMART-I.S., SQI, SuperSwitcher, SuperSwitcher II, Total Endurance, TSHARC, USBCheck, VariSense, ViewSpan, WiperLock, Wireless DNA, and ZENA are trademarks of Microchip Technology Incorporated in the U.S.A. and other countries.

SQTP is a service mark of Microchip Technology Incorporated in the U.S.A.

Silicon Storage Technology is a registered trademark of Microchip Technology Inc. in other countries.

GestIC is a registered trademark of Microchip Technology Germany II GmbH & Co. KG, a subsidiary of Microchip Technology Inc., in other countries.

All other trademarks mentioned herein are property of their respective companies.

© 2016, Microchip Technology Incorporated, All Rights Reserved.  
ISBN: 978-1-5224-1200-7



# MICROCHIP

## Worldwide Sales and Service

### AMERICAS

**Corporate Office**  
2355 West Chandler Blvd.  
Chandler, AZ 85224-6199  
Tel: 480-792-7200  
Fax: 480-792-7277  
Technical Support:  
<http://www.microchip.com/support>  
Web Address:  
[www.microchip.com](http://www.microchip.com)

**Atlanta**  
Duluth, GA  
Tel: 678-957-9614  
Fax: 678-957-1455

**Austin, TX**  
Tel: 512-257-3370

**Boston**  
Westborough, MA  
Tel: 774-760-0087  
Fax: 774-760-0088

**Chicago**  
Itasca, IL  
Tel: 630-285-0071  
Fax: 630-285-0075

**Dallas**  
Addison, TX  
Tel: 972-818-7423  
Fax: 972-818-2924

**Detroit**  
Novi, MI  
Tel: 248-848-4000

**Houston, TX**  
Tel: 281-894-5983

**Indianapolis**  
Noblesville, IN  
Tel: 317-773-8323  
Fax: 317-773-5453  
Tel: 317-536-2380

**Los Angeles**  
Mission Viejo, CA  
Tel: 949-462-9523  
Fax: 949-462-9608  
Tel: 951-273-7800

**Raleigh, NC**  
Tel: 919-844-7510

**New York, NY**  
Tel: 631-435-6000

**San Jose, CA**  
Tel: 408-735-9110  
Tel: 408-436-4270

**Canada - Toronto**  
Tel: 905-695-1980  
Fax: 905-695-2078

### ASIA/PACIFIC

**Asia Pacific Office**  
Suites 3707-14, 37th Floor  
Tower 6, The Gateway  
Harbour City, Kowloon

**Hong Kong**  
Tel: 852-2943-5100  
Fax: 852-2401-3431

**Australia - Sydney**  
Tel: 61-2-9868-6733  
Fax: 61-2-9868-6755

**China - Beijing**  
Tel: 86-10-8569-7000  
Fax: 86-10-8528-2104

**China - Chengdu**  
Tel: 86-28-8665-5511  
Fax: 86-28-8665-7889

**China - Chongqing**  
Tel: 86-23-8980-9588  
Fax: 86-23-8980-9500

**China - Dongguan**  
Tel: 86-769-8702-9880

**China - Guangzhou**  
Tel: 86-20-8755-8029

**China - Hangzhou**  
Tel: 86-571-8792-8115  
Fax: 86-571-8792-8116

**China - Hong Kong SAR**  
Tel: 852-2943-5100  
Fax: 852-2401-3431

**China - Nanjing**  
Tel: 86-25-8473-2460  
Fax: 86-25-8473-2470

**China - Qingdao**  
Tel: 86-532-8502-7355  
Fax: 86-532-8502-7205

**China - Shanghai**  
Tel: 86-21-3326-8000  
Fax: 86-21-3326-8021

**China - Shenyang**  
Tel: 86-24-2334-2829  
Fax: 86-24-2334-2393

**China - Shenzhen**  
Tel: 86-755-8864-2200  
Fax: 86-755-8203-1760

**China - Wuhan**  
Tel: 86-27-5980-5300  
Fax: 86-27-5980-5118

**China - Xian**  
Tel: 86-29-8833-7252  
Fax: 86-29-8833-7256

### ASIA/PACIFIC

**China - Xiamen**  
Tel: 86-592-2388138  
Fax: 86-592-2388130

**China - Zhuhai**  
Tel: 86-756-3210040  
Fax: 86-756-3210049

**India - Bangalore**  
Tel: 91-80-3090-4444  
Fax: 91-80-3090-4123

**India - New Delhi**  
Tel: 91-11-4160-8631  
Fax: 91-11-4160-8632

**India - Pune**  
Tel: 91-20-3019-1500

**Japan - Osaka**  
Tel: 81-6-6152-7160  
Fax: 81-6-6152-9310

**Japan - Tokyo**  
Tel: 81-3-6880-3770  
Fax: 81-3-6880-3771

**Korea - Daegu**  
Tel: 82-53-744-4301  
Fax: 82-53-744-4302

**Korea - Seoul**  
Tel: 82-2-554-7200  
Fax: 82-2-558-5932 or  
82-2-558-5934

**Malaysia - Kuala Lumpur**  
Tel: 60-3-6201-9857  
Fax: 60-3-6201-9859

**Malaysia - Penang**  
Tel: 60-4-227-8870  
Fax: 60-4-227-4068

**Philippines - Manila**  
Tel: 63-2-634-9065  
Fax: 63-2-634-9069

**Singapore**  
Tel: 65-6334-8870  
Fax: 65-6334-8850

**Taiwan - Hsin Chu**  
Tel: 886-3-5778-366  
Fax: 886-3-5770-955

**Taiwan - Kaohsiung**  
Tel: 886-7-213-7830

**Taiwan - Taipei**  
Tel: 886-2-2508-8600  
Fax: 886-2-2508-0102

**Thailand - Bangkok**  
Tel: 66-2-694-1351  
Fax: 66-2-694-1350

### EUROPE

**Austria - Wels**  
Tel: 43-7242-2244-39  
Fax: 43-7242-2244-393

**Denmark - Copenhagen**  
Tel: 45-4450-2828  
Fax: 45-4485-2829

**Finland - Espoo**  
Tel: 358-9-4520-820

**France - Paris**  
Tel: 33-1-69-53-63-20  
Fax: 33-1-69-30-90-79

**France - Saint Cloud**  
Tel: 33-1-30-60-70-00

**Germany - Garching**  
Tel: 49-8931-9700

**Germany - Haan**  
Tel: 49-2129-3766400

**Germany - Heilbronn**  
Tel: 49-7131-67-3636

**Germany - Karlsruhe**  
Tel: 49-721-625370

**Germany - Munich**  
Tel: 49-89-627-144-0  
Fax: 49-89-627-144-44

**Germany - Rosenheim**  
Tel: 49-8031-354-560

**Israel - Ra'anana**  
Tel: 972-9-744-7705

**Italy - Milan**  
Tel: 39-0331-742611  
Fax: 39-0331-466781

**Italy - Padova**  
Tel: 39-049-7625286

**Netherlands - Drunen**  
Tel: 31-416-690399  
Fax: 31-416-690340

**Norway - Trondheim**  
Tel: 47-7289-7561

**Poland - Warsaw**  
Tel: 48-22-3325737

**Romania - Bucharest**  
Tel: 40-21-407-87-50

**Spain - Madrid**  
Tel: 34-91-708-08-90  
Fax: 34-91-708-08-91

**Sweden - Gothenberg**  
Tel: 46-31-704-60-40

**Sweden - Stockholm**  
Tel: 46-8-5090-4654

**UK - Wokingham**  
Tel: 44-118-921-5800  
Fax: 44-118-921-5820



## X-ON Electronics

Largest Supplier of Electrical and Electronic Components

*Click to view similar products for [Gate Drivers](#) category:*

*Click to view products by [Microchip](#) manufacturer:*

Other Similar products are found below :

[89076GBEST](#) [00053P0231](#) [56956](#) [57.404.7355.5](#) [LT4936](#) [57.904.0755.0](#) [5882900001](#) [00600P0005](#) [00-9050-LRPP](#) [00-9090-RDPP](#)  
[5951900000](#) [01-1003W-10/32-15](#) [0131700000](#) [00-2240](#) [LTP70N06](#) [LVP640](#) [5J0-1000LG-SIL](#) [LY1D-2-5S-AC120](#) [LY2-US-AC240](#) [LY3-](#)  
[UA-DC24](#) [00576P0020](#) [00600P0010](#) [LZN4-UA-DC12](#) [LZNQ2M-US-DC5](#) [LZNQ2-US-DC12](#) [LZP40N10](#) [00-8196-RDPP](#) [00-8274-RDPP](#)  
[00-8275-RDNP](#) [00-8722-RDPP](#) [00-8728-WHPP](#) [00-8869-RDPP](#) [00-9051-RDPP](#) [00-9091-LRPP](#) [00-9291-RDPP](#) [0207100000](#) [0207400000](#)  
[01312](#) [0134220000](#) [60713816](#) [M15730061](#) [61161-90](#) [61278-0020](#) [6131-204-23149P](#) [6131-205-17149P](#) [6131-209-15149P](#) [6131-218-17149P](#)  
[6131-220-21149P](#) [6131-260-2358P](#) [6131-265-11149P](#)