

General Description

The MIC5363/4 is an advanced, 300mA LDO ideal for powering general purpose portable devices requiring a high power supply rejection ratio (PSRR). The MIC5363/4 integrates a high-performance, 300mA LDO into a tiny 1.2mm x 1.2mm Thin MLF[®] package.

The MIC5363/4 is designed to reject input noise and provide a low output noise regulator with fast transient response to respond to any load change quickly. The MIC5364 also incorporates an active discharge feature that switches a 30 Ω NFET from VOUT to GND to discharge output capacitors when the part is disabled.

The MIC5363/4 is available in fixed output voltages in lead-free (RoHS-compliant) 6-pin 1.2mm x 1.2mm Thin MLF[®] leadless package.

Data sheets and support documentation can be found on Micrel's web site at: www.micrel.com.

Features

- 2.5V to 5.5V input voltage range
- 300mA output
- High output accuracy : $\pm 2\%$
- Low quiescent current : typically 38 μ A
- Stable with 1 μ F ceramic capacitors
- High PSRR (70dB @1kHz)
- Low dropout voltage : 225mV at 300mA
- Thermal-shutdown protection
- Current-limit protection
- Active Output discharge circuit : MIC5364
- 6-pin 1.2mm x 1.2mm Thin MLF[®] package

Applications

- Mobile phones
- GPS, PMP, and DSC
- Battery-powered electronics
- Noise Sensitive Applications

Typical Application

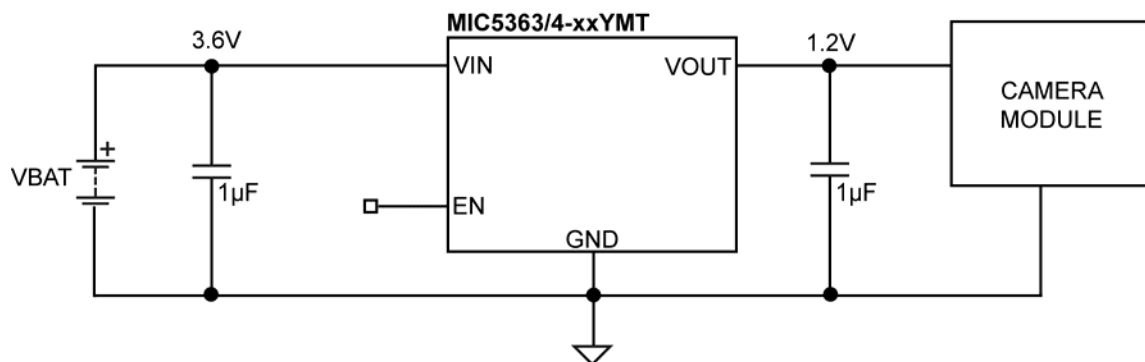

Camera DSP Power Supply

Ordering Information

Part Number	Marking Code	Voltage ⁽¹⁾	Junction Temperature Range	Package ⁽²⁾	Lead Finish ⁽³⁾
MIC5363-1.2YMT	34	1.2	-40°C to +125°C	6-Pin 1.2 mm × 1.2mm Thin MLF [®]	Pb-Free
MIC5363-2.8YMT	3G	2.8	-40°C to +125°C	6-Pin 1.2 mm × 1.2mm Thin MLF [®]	Pb-Free
MIC5363-3.3YMT	3S	3.3	-40°C to +125°C	6-Pin 1.2 mm × 1.2mm Thin MLF [®]	Pb-Free
MIC5364-1.2YMT ⁽⁴⁾	44	1.2	-40°C to +125°C	6-Pin 1.2 mm × 1.2mm Thin MLF [®]	Pb-Free
MIC5364-2.8YMT ⁽⁴⁾	4X	2.8	-40°C to +125°C	6-Pin 1.2 mm × 1.2mm Thin MLF [®]	Pb-Free
MIC5364-3.3YMT ⁽⁴⁾	4S	3.3	-40°C to +125°C	6-Pin 1.2 mm × 1.2mm Thin MLF [®]	Pb-Free

Notes:

- Other voltages available. Contact Micrel for details.
- “▲” = Pin 1 identifier.
- Green, RoHS-compliant. Level finish is NiPdAu. Mold compound is Halogen free.
- MIC5364 offers Auto-Discharge function.

Pin Configuration

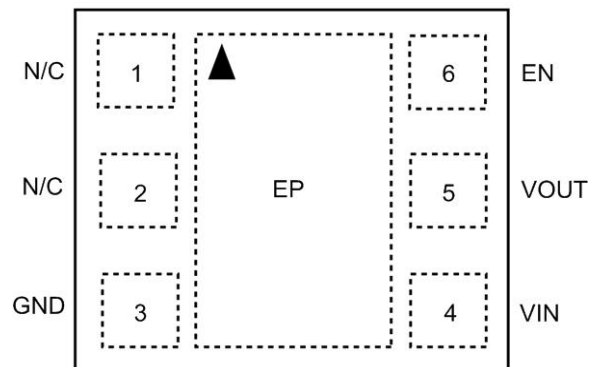

6-Pin 1.2mm × 1.2mm Thin MLF[®] (MT)

Pin Description

Pin Number	Pin Name	Pin Function
1	N/C	Not internally connected.
2	N/C	Not internally connected.
3	GND	Ground.
4	VIN	Supply Input. Decouple with 1μF ceramic capacitor.
5	VOUT	Output Voltage. Decouple with 1μF ceramic capacitor.
6	EN	Enable Input. Active HIGH. Logic HIGH = ON, logic LOW = OFF. Do not leave floating.
EP	ePad	Exposed Heatsink Pad. Connect to ground for best thermal performance.

Absolute Maximum Ratings⁽¹⁾

Supply Voltage (V_{IN})	-0.3V to +6V
Enable Voltage (V_{EN})	-0.3V to $V_{IN} + 0.3V$
Power Dissipation (P_D)	Internally Limited ⁽³⁾
Lead Temperature (soldering, 10s)	260°C
Junction Temperature (T_J)	-40°C to +125°C
Storage Temperature (T_S)	-65°C to +150°C
ESD Rating ⁽⁴⁾	2kV

Operating Ratings⁽²⁾

Supply Voltage (V_{IN})	+2.5V to +5.5V
Enable Voltage (V_{EN})	0V to V_{IN}
Junction Temperature (T_J)	-40°C to +125°C
Junction Thermal Resistance	
1.2mm × 1.2mm Thin MLF [®] (θ_{JA})	173°C/W

Electrical Characteristics⁽⁵⁾

$V_{IN} = V_{EN} = V_{OUT} + 1V$, 2.5V if $V_{OUT} \leq 1.5V$; $I_{OUT} = 100\mu A$; $C_{OUT} = 1\mu F$; $T_J = 25^\circ C$, **bold** values indicate -40°C to +125°C, unless noted.

Parameter	Condition	Min.	Typ.	Max.	Units
Output Voltage Accuracy	Variation from nominal V_{OUT}	-2.0		2.0	%
	Variation from nominal V_{OUT} , -40°C to +125°C	-3.0		3.0	
Line Regulation ⁽⁶⁾	$V_{IN} = \text{Max}(V_{OUT} + 1V, 2.5V)$ to 5.5V, $I_{OUT} = 100\mu A$		0.02	0.2	%/V
Load Regulation	$I_{OUT} = 100\mu A$ to 300mA		0.3	0.7	%
Dropout Voltage	$I_{OUT} = 50mA$; $V_{OUT} \geq 2.8V$		35	65	mV
	$I_{OUT} = 300mA$; $V_{OUT} \geq 2.8V$		225	380	
	$I_{OUT} = 50mA$; $2.5V \leq V_{OUT} < 2.8V$		55	100	
	$I_{OUT} = 300mA$; $2.5V \leq V_{OUT} < 2.8V$		300	600	
Ground Pin Current	$V_{EN} = \text{High}$; $I_{OUT} = 0mA$		38	53	μA
	$V_{EN} = \text{High}$; $I_{OUT} = 300mA$		55	70	
Shutdown Current	$V_{EN} = 0V$		0.1	1	μA
Supply Ripple Rejection	$f = 1kHz$; $C_{OUT} = 1\mu F$		70		dB
Current Limit	$V_{OUT} = 0V$	325	520	680	mA
Output Voltage Noise	$C_{OUT} = 1\mu F$; 10Hz to 100kHz		200		μV_{RMS}
Auto-Discharge NFET Resistance	MIC5364 only; $V_{EN} = 0V$; $V_{IN} = 3.6V$; $I_{OUT} = -3mA$		30		Ω
Enable Inputs (EN)					
Enable Input Voltage	Logic Low			0.2	V
	Logic High	1.2			
Enable Input Current	$V_{IL} \leq 0.2V$		0.01	1	μA
	$V_{IH} \geq 1.2V$		0.01	1	
Turn-On Time	$C_{OUT} = 1\mu F$		60	150	μs

Notes:

- Exceeding the absolute maximum rating may damage the device.
- The device is not guaranteed to function outside its operating rating.
- The maximum allowable power dissipation of any T_A (ambient temperature) is $P_{D(max)} = (T_{J(max)} - T_A) / \theta_{JA}$. Exceeding the maximum allowable power dissipation will result in excessive die temperature, and the regulator will go into thermal shutdown.
- Devices are ESD sensitive. Handling precautions recommended. Human body model, 1.5k Ω in series with 100pF.
- Specification for packaged product only.
- Regulation is measured at constant junction temperature using low duty cycle pulse testing; changes in output voltage due to heating effects are covered by the thermal regulation specification.
- Dropout voltage is defined as the input-to-output differential at which the output voltage drops 2% below its nominal value.

Typical Characteristics

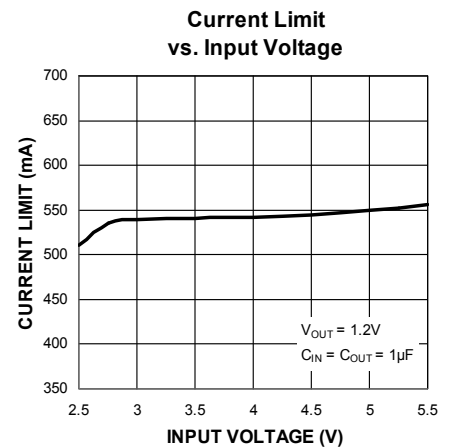
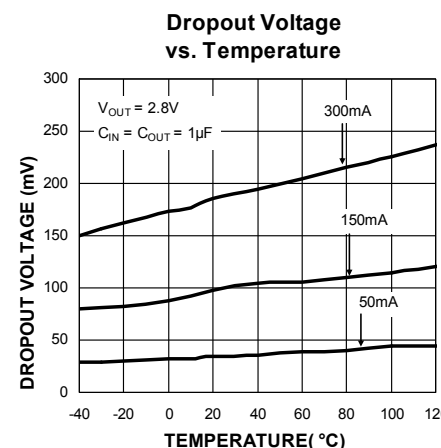
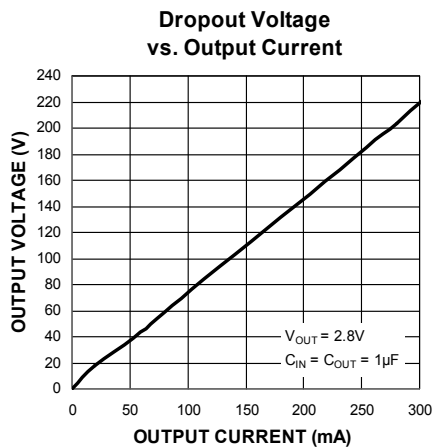
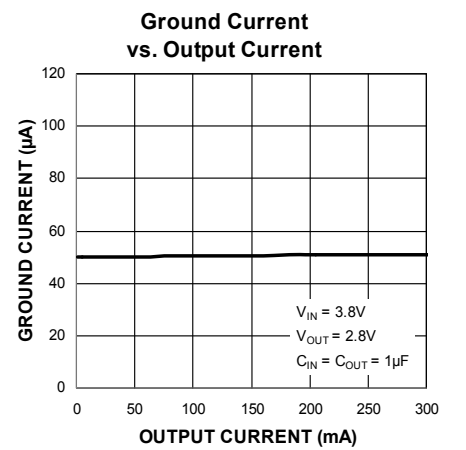
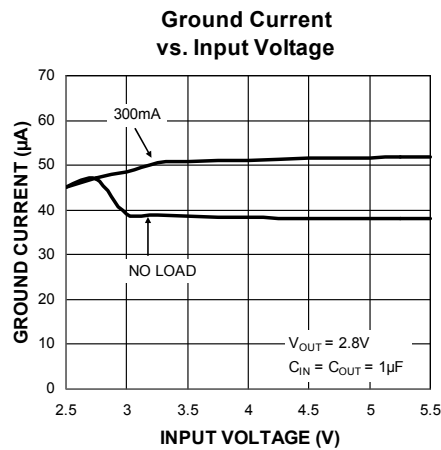
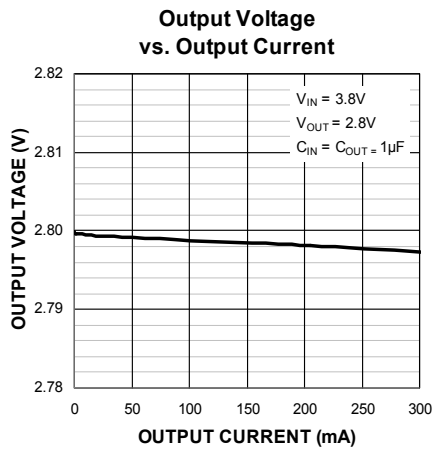
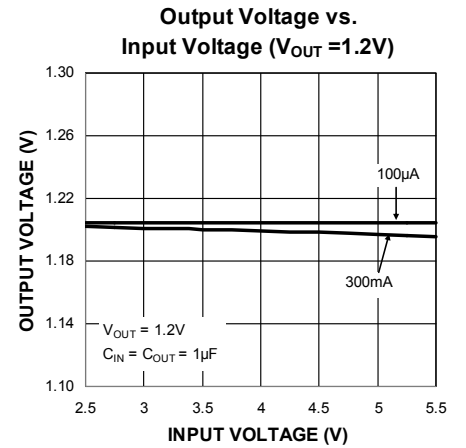
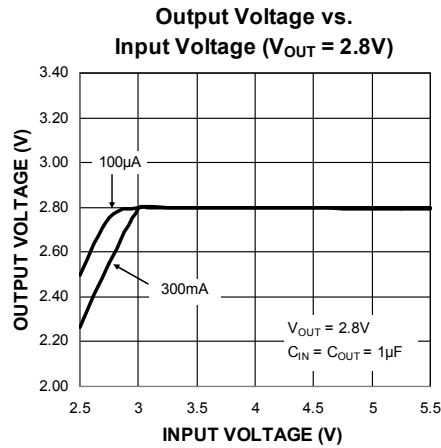
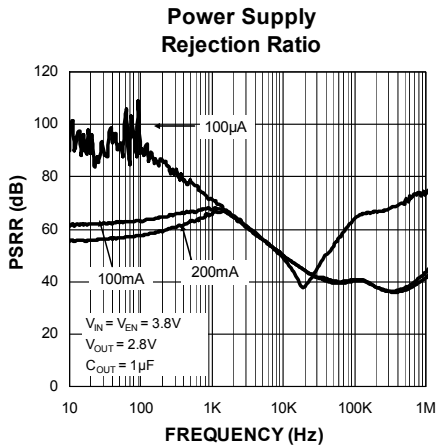

Typical Characteristics (Continued)

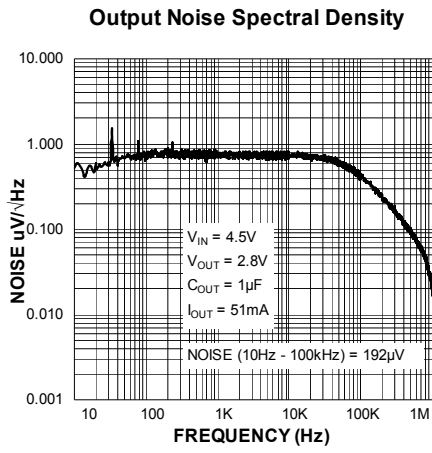

Functional Characteristics

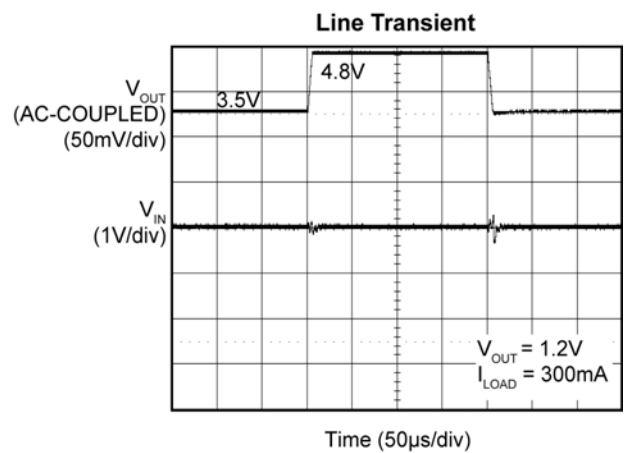
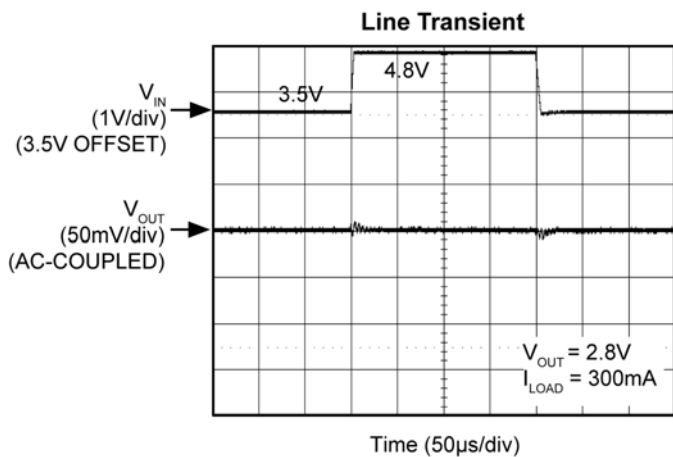
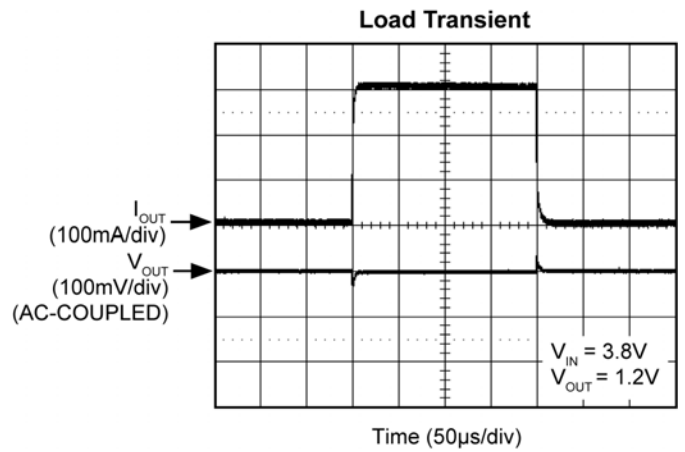
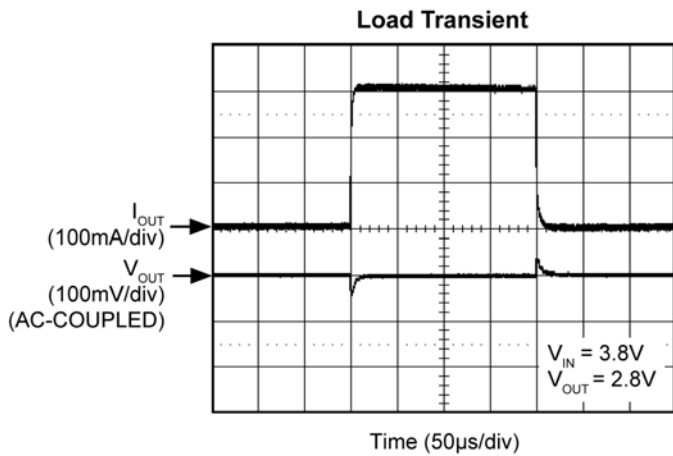
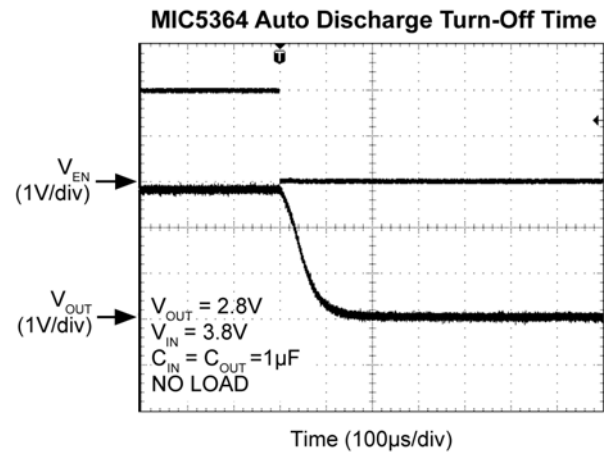
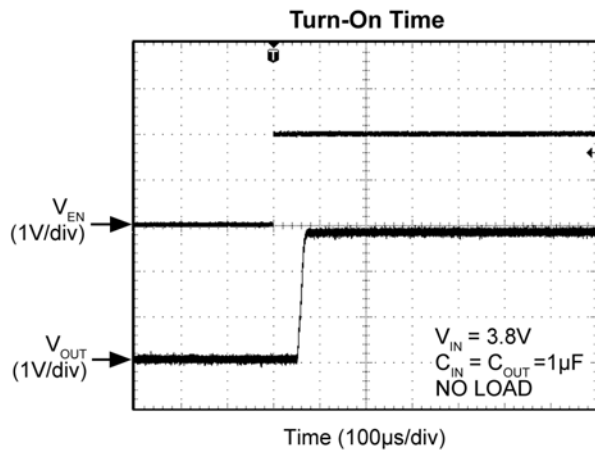

Functional Diagram

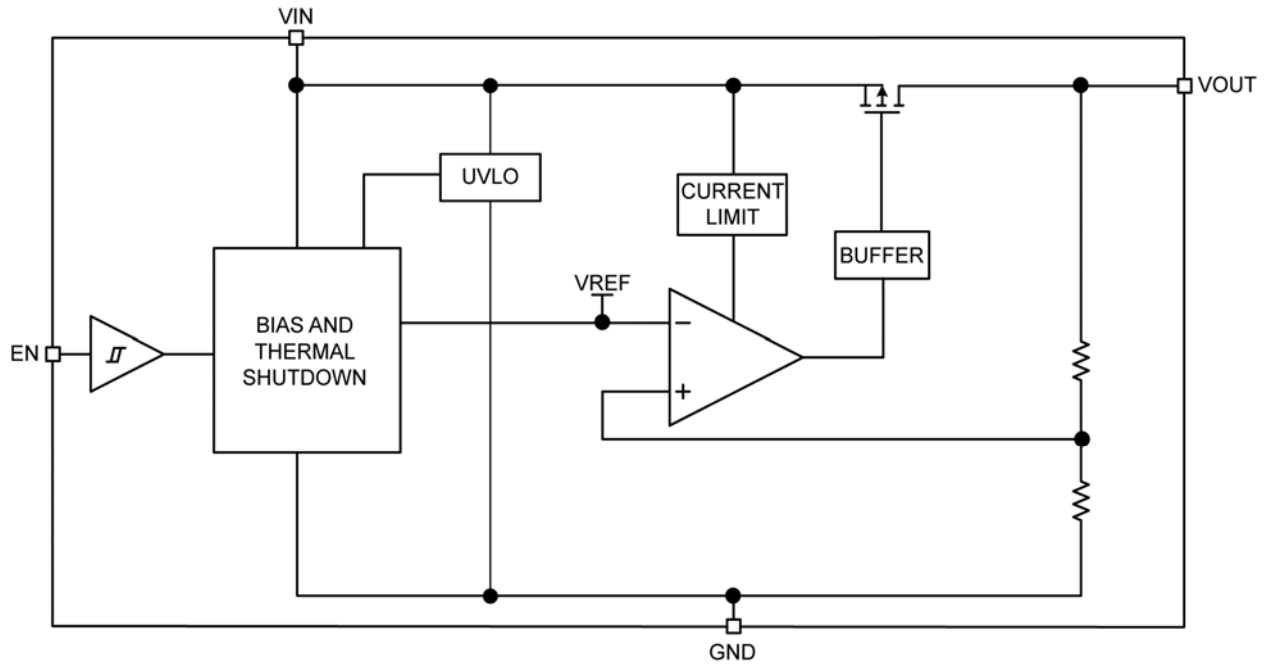

MIC5363 Block Diagram

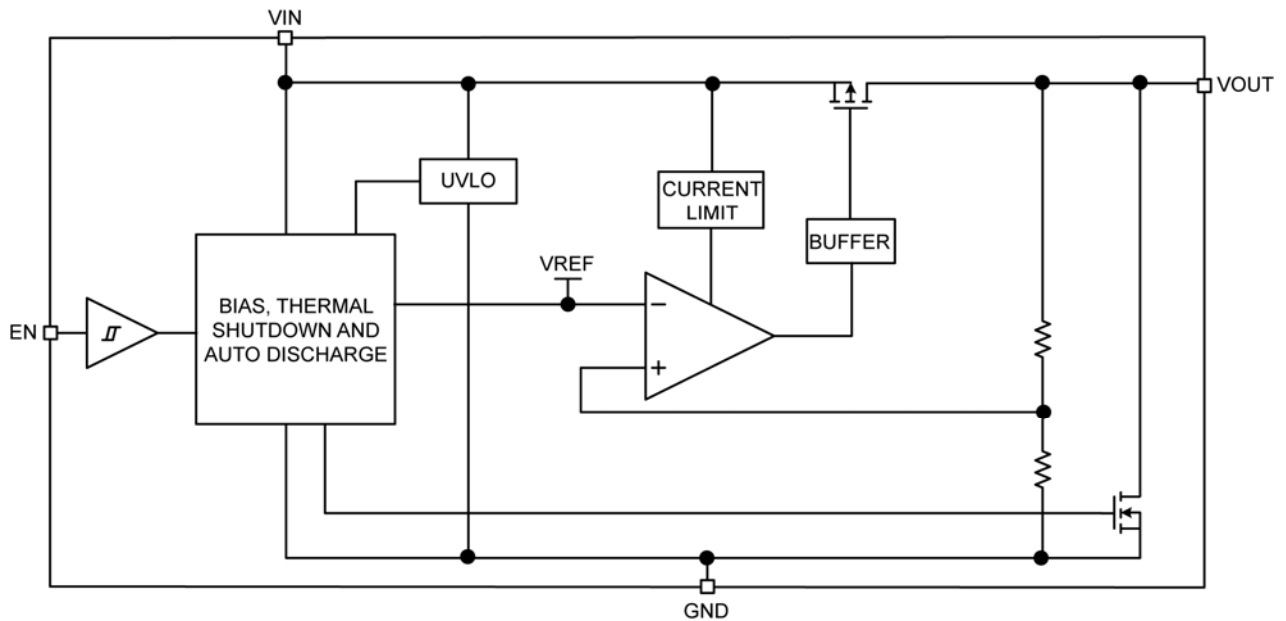

MIC5364 Block Diagram

Application Information

The MIC5363/4 is a 300mA LDO, packaged in a 1.2mm x 1.2mm Thin MLF[®] package. The MIC5364 includes an auto-discharge feature which automatically discharges the output capacitor when the output is disabled. The MIC5363/4 consists of an internal reference, error amplifier, P-channel pass transistor, and internal feedback resistors. The error amplifier compares the feedback voltage with that of the reference. Depending upon whether the feedback is lower or higher than the reference determines whether the gate of the pass transistor is pulled low to allow more current and increase output voltage or pulled high to reduce current. The MIC5363/4 regulator is fully protected from damage due to fault conditions through linear current limiting and thermal shutdown.

Input Capacitor

The MIC5363/4 is a high-performance, high-bandwidth device. An input capacitor of 1 μ F from the input pin to ground is required to provide stability. Low-ESR ceramic capacitors provide optimal performance in small board area. Additional high-frequency capacitors, such as small valued NPO dielectric type capacitors, help filter out high-frequency noise and are good practice in any RF-based circuit. X5R or X7R dielectrics are recommended for the input capacitor. Y5V dielectrics lose most of their capacitance over temperature and are therefore not recommended.

Output Capacitor

The MIC5363/4 requires an output capacitor of 1 μ F or greater to maintain stability. The design is optimized for use with low-ESR ceramic chip capacitors. High-ESR capacitors may cause high-frequency oscillation. The output capacitor can be increased, but performance has been optimized for a 1 μ F ceramic output capacitor.

X7R and X5R dielectric ceramic capacitors are recommended for their temperature performance. X7R capacitors change capacitance by 15% over their operating temperature range and are the most stable type of ceramic capacitors. Z5U and Y5V dielectric capacitors change value by as much as 50% and 60% respectively over their operating temperature ranges. To use a ceramic-chip capacitor with Y5V dielectric the value must be much higher than an X7R ceramic capacitor to ensure the same minimum capacitance over the equivalent operating temperature range.

No Load Stability

The MIC5363/4 will remain stable and in regulation without the need of a minimum load. This reduces the amount and therefore cost of external components.

Enable/Shutdown

The MIC5363/4 comes with an active-high enable pin that allows the regulator to be disabled. Forcing the enable pin low disables the regulator and sends it into an off-mode current state drawing virtually zero current. When disabled, the MIC5364 switches an internal 30 Ω load on the regulator output to discharge the external capacitor.

Forcing the enable pin high enables the output voltage. The active-high enable pin uses CMOS technology and cannot be left floating. A floating enable pin may cause an indeterminate state on the output.

Thermal Considerations

The MIC5363/4 is designed to provide a 300mA continuous current output in a very-small package. Maximum operating temperature can be calculated based on the output currents and the voltage drop across the part. For example, if the input voltage is 3.6V, $V_{OUT} = 2.8V$ and the output current = 300mA. The actual power dissipation of the regulator circuit can be determined using the equation:

$$P_D = (V_{IN} - V_{OUT}) I_{OUT} + V_{IN} I_{GND}$$

Because this is a CMOS device and the ground current is typically <60 μ A over the load range, the power dissipation contributed by the ground current is < 1% which can be ignored for this calculation:

$$P_D = (3.6V - 2.8V) \times 300mA$$

$$P_D = 0.24W$$

To determine the maximum ambient operating temperature of the package, use the junction to ambient thermal resistance of the device and the following basic equation:

$$P_{D(MAX)} = \left(\frac{T_{J(MAX)} - T_A}{\theta_{JA}} \right)$$

$$T_{J(MAX)} = 125^\circ C$$

$$\theta_{JA} = 173^\circ C/W$$

Substituting P_D for $P_{D(MAX)}$ and solving for the ambient operating temperature will give the maximum operating conditions for the regulator circuit. The junction-to-ambient thermal resistance for the standard footprint is 173°C/W .

The maximum power dissipation must not be exceeded for proper operation.

For example, when operating a 2.8V application with an input voltage of 3.6V and 300mA output with a standard footprint layout, the maximum ambient operating temperature T_A can be determined as follows:

$$0.24\text{W} = (125^{\circ}\text{C} - T_A) / (173^{\circ}\text{C/W})$$

$$T_A = 83^{\circ}\text{C}$$

Therefore, a MIC5363-2.8YMT application with a 300mA output current can accept an ambient operating temperature of 83°C in a 1.2mm x 1.2mm Thin MLF[®] package. For a full discussion of heat sinking and thermal effects on voltage regulators refer to the "Regulator Thermals" section of Micrel's *Designing with Low-Dropout Voltage Regulators* handbook. This information can be found on Micrel's website at:

http://www.micrel.com/PDF/other/LDOBk_ds.pdf

Evaluation Board Schematic

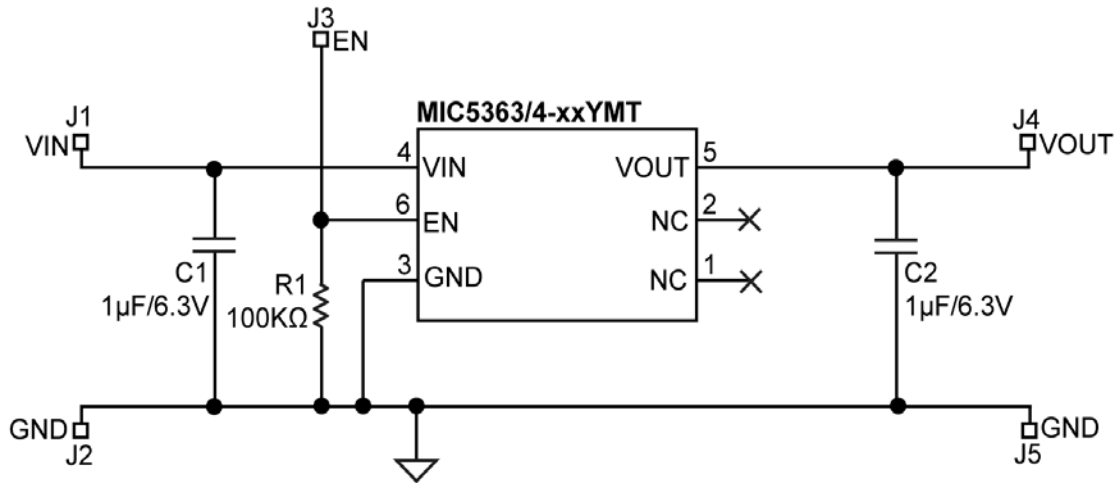

Bill of Materials

Item	Part Number	Manufacturer	Description	Qty.
C1, C2	GRM155R61A105KE15D	Murata ⁽¹⁾	1µF/6.3V ceramic capacitor, X5R, size 0402	2
R1	CRCW04021003FKED	Vishay ⁽²⁾	Resistor, 100k (0403 size), 1%	1
U1	MIC5363/4-xxYMT	Micrel, Inc. ⁽³⁾	300mA µCap LDO in 1.2mm × 1.2mm Thin MLF®	1

Notes:

1. Murata Tel: www.murata.com.
2. Vishay: www.vishay.com.
3. Micrel, Inc.: www.micrel.com.

PCB Layout Recommendations

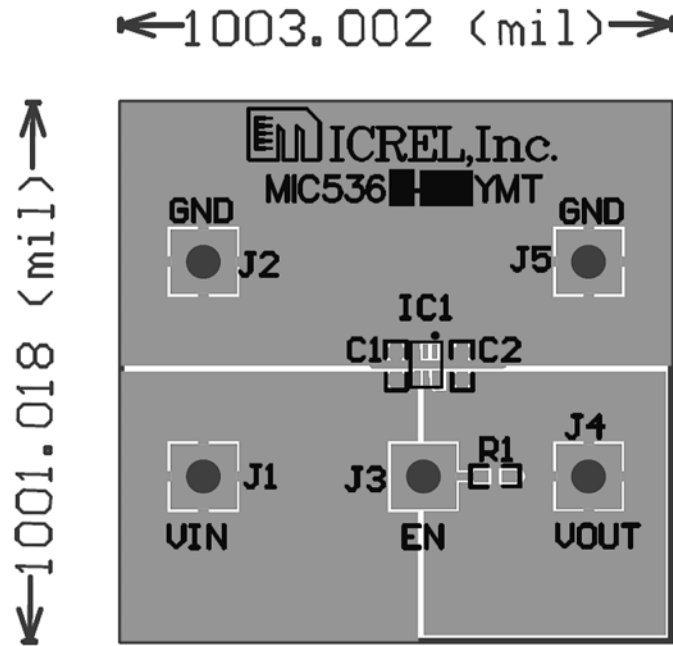

Top Layer

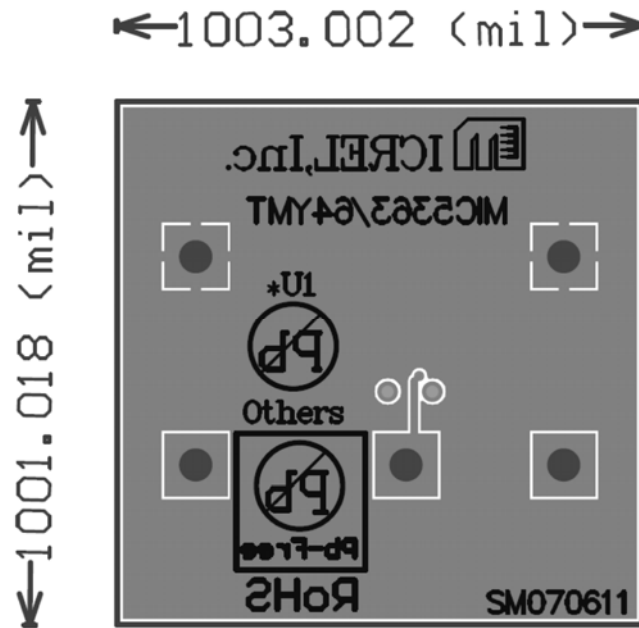

Bottom Layer

Package Information

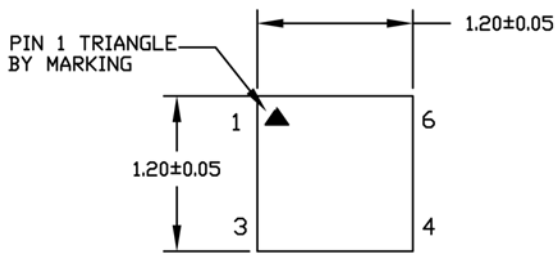

TOP VIEW

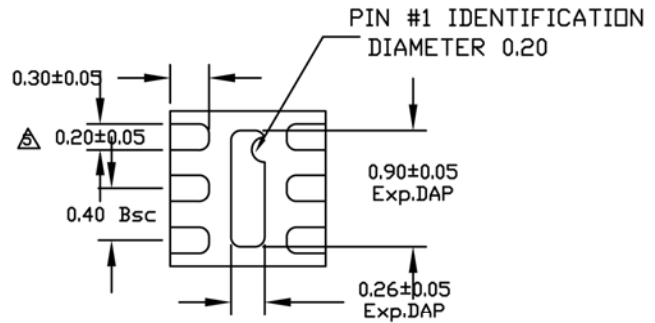

BOTTOM VIEW

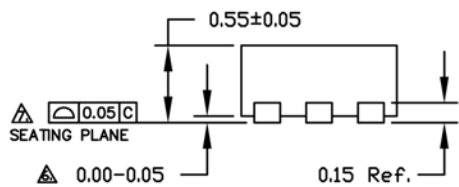

SIDE VIEW

- NOTES :
1. ALL DIMENSIONS ARE IN MILLIMETERS.
 2. MAX. PACKAGE WARPAGE IS 0.05 mm.
 3. MAXIMUM ALLOWABLE BURRS IS 0.08 mm IN ALL DIRECTIONS.
 4. PIN #1 ID ON TOP WILL BE LASER/INK MARKED.
 5. DIMENSION APPLIES TO METALIZED TERMINAL AND IS MEASURED BETWEEN 0.20 AND 0.25 mm FROM TERMINAL TIP.
 6. APPLIED ONLY FOR TERMINALS.
 7. APPLIED FOR EXPOSED PAD AND TERMINALS

6-Pin 1.2mm × 1.2mm Thin MLF®

MICREL, INC. 2180 FORTUNE DRIVE SAN JOSE, CA 95131 USA
 TEL +1 (408) 944-0800 FAX +1 (408) 474-1000 WEB <http://www.micrel.com>

Micrel makes no representations or warranties with respect to the accuracy or completeness of the information furnished in this data sheet. This information is not intended as a warranty and Micrel does not assume responsibility for its use. Micrel reserves the right to change circuitry, specifications and descriptions at any time without notice. No license, whether express, implied, arising by estoppel or otherwise, to any intellectual property rights is granted by this document. Except as provided in Micrel's terms and conditions of sale for such products, Micrel assumes no liability whatsoever, and Micrel disclaims any express or implied warranty relating to the sale and/or use of Micrel products including liability or warranties relating to fitness for a particular purpose, merchantability, or infringement of any patent, copyright or other intellectual property right.

Micrel Products are not designed or authorized for use as components in life support appliances, devices or systems where malfunction of a product can reasonably be expected to result in personal injury. Life support devices or systems are devices or systems that (a) are intended for surgical implant into the body or (b) support or sustain life, and whose failure to perform can be reasonably expected to result in a significant injury to the user. A Purchaser's use or sale of Micrel Products for use in life support appliances, devices or systems is a Purchaser's own risk and Purchaser agrees to fully indemnify Micrel for any damages resulting from such use or sale.

© 2012 Micrel, Incorporated.

X-ON Electronics

Largest Supplier of Electrical and Electronic Components

Click to view similar products for [LDO Voltage Regulators](#) category:

Click to view products by [Microchip](#) manufacturer:

Other Similar products are found below :

[M38D29FFHP#U1](#) [702103A](#) [717726C](#) [742457H](#) [MP20051DN-LF-Z](#) [R5F111PGGFB#30](#) [AP7363-SP-13](#) [NCP103AMX285TCG](#)
[NCV8664CST33T3G](#) [NCV8752AMX28TCG](#) [L9454](#) [AP7362-HA-7](#) [LX13043CLD](#) [TCR3DF185,LM\(CT](#) [TCR3DF24,LM\(CT](#)
[TCR3DF285,LM\(CT](#) [TCR3DF31,LM\(CT](#) [TCR3DF45,LM\(CT](#) [TLF4949EJ](#) [MP2013GQ-33-Z](#) [L9708](#) [L970813TR](#) [030014BB](#) [059985X](#)
[EAN61387601](#) [EAN61573601](#) [NCP121AMX173TCG](#) [NCP4687DH15T1G](#) [NCV8703MX30TCG](#) [701326R](#) [702087BB](#) [755078E](#)
[TCR2EN28,LF\(S](#) [LM1117DT-1.8/NO](#) [LT1086CM#TRPBF](#) [AZ1085S2-1.5TRE1](#) [MAX15101EWL+T](#) [NCV8170AXV250T2G](#)
[TCR3DF27,LM\(CT](#) [TCR3DF19,LM\(CT](#) [TCR3DF125,LM\(CT](#) [TCR2EN18,LF\(S](#) [MAX15103EWL+T](#) [TS2937CZ-5.0 C0](#) [MAX8878EUK30-](#)
[T](#) [MAX663CPA](#) [NCV4269CPD50R2G](#) [NCV8716MT30TBG](#) [AZ1117IH-1.2TRG1](#) [MP2013GQ-P](#)