

## General Description

The MIC706 and MIC708 are inexpensive microprocessor supervisory circuits that monitor power supplies in 3.0V and 3.3V microprocessor-based systems. The circuit functions include a watchdog timer, microprocessor reset, power-failure warning, and a debounced manual reset input.

The MIC706 offers a watchdog timer function, while the MIC708 has an active-high reset output in addition to the active-low reset output.

The R, S, and T versions are similar in all respects except for supply voltage reset threshold levels. The threshold levels are 2.63, 2.93, and 3.08V, respectively. When the supply voltage drops below the reset threshold level, /RESET (and RESET for the MIC708) is asserted.

The MIC706P is identical to the MIC706R, except that the Reset output is asserted high.

Datasheets and support documentation are available on Micrel's web site at: [www.micrel.com](http://www.micrel.com).

## Features

- Maximum supply current: 30µA
- Debounced manual reset input is TTL/CMOS compatible
- Reset pulse width: 200ms
- Watchdog timer: 1.6s (MIC706)
- Precision supply voltage monitor
- Easy power-fail warning or low-battery detect

## Applications

- Laptop and desktop computers
- Intelligent systems
- Critical microprocessor power monitoring
- Printers
- Controllers

## Typical Application

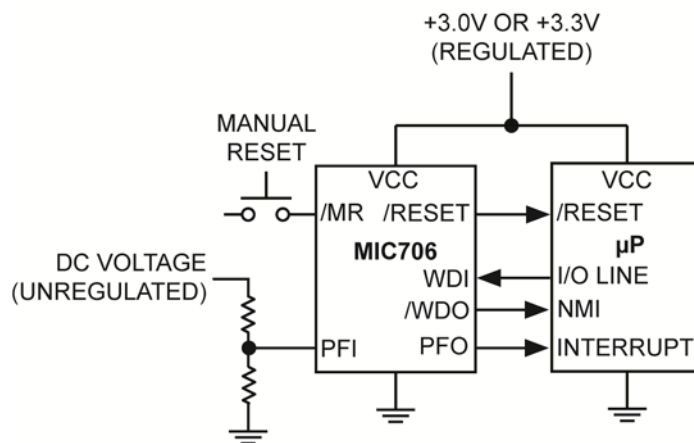

### Ordering Information

Part Number	Threshold (V)	/RESET	RESET	WDI	Junction Temperature Range	Package
MIC706PMY	2.63		√	√	-40°C to +85°C	8-Pin SOIC
MIC706RMY	2.63	√		√	-40°C to +85°C	8-Pin SOIC
MIC706SMY	2.93	√		√	-40°C to +85°C	8-Pin SOIC
MIC706TMY	3.08	√		√	-40°C to +85°C	8-Pin SOIC
MIC708RMY	2.63	√	√		-40°C to +85°C	8-Pin SOIC
MIC708SMY	2.93	√	√		-40°C to +85°C	8-Pin SOIC
MIC708TMY	3.08	√	√		-40°C to +85°C	8-Pin SOIC

### Pin Configuration

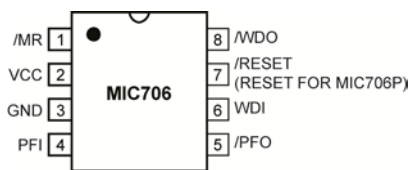

**MIC706**  
8-Pin SOIC (M)  
(Top View)

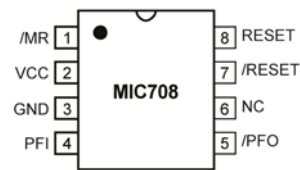

**MIC708**  
8-Pin SOIC (M)  
(Top View)

### Pin Description

Pin Number MIC706	Pin Number MIC708	Pin Name	Pin Name
1	1	/MR	Manual reset input forces reset outputs to assert when pulled below 0.8V. An internal pull-up current of 250µA on this input forces it high when left floating. This input can also be driven from TTL or CMOS logic.
2	2	VCC	Primary supply input, +5V.
3	3	GND	IC ground pin, 0V reference.
4	4	PFI	Power-Fail Input: Internally-connected to the power-fail comparator which is referenced to 1.25V. The power-fail output (/PFO) remains high if PFI is above 1.25V. PFI should be connected to GND or V <sub>OUT</sub> if the power-fail comparator is not used.
5	5	/PFO	Power-Fail Output: The power-fail comparator is independent of all other function on this device.
6	N/A	WDI	Watchdog Input. The WDI input monitors microprocessor activity; an internal watchdog timer resets itself with each transition on the watchdog input. If the WDI pin is held high or low for longer than the watchdog timeout period, /WDO is forced to active low. The watchdog function can be disabled by floating the WDI pin.
N/A	6	N/C	Not internally connected.

**Pin Description (Continued)**

Pin Number MIC706	Pin Number MIC708	Pin Name	Pin Name
7	7	/RESET	/RESET is asserted if either V <sub>CC</sub> goes below the reset threshold voltage or by low signal on the manual reset input (/MR). /RESET remains asserted for one reset timeout period (200ms) after V <sub>CC</sub> exceeds the reset threshold voltage or after the manual reset pin transition from low to high. The watchdog timer will not assert /RESET unless /WDO is connected to /MR.
8	N/A	/WDO	Output for the watchdog timer. The watchdog timer resets itself with each transition to the watchdog input. If the WDI pin is held high or low for longer than the watchdog timeout period, /WDO is forced low. /WDO will also be forced low if V <sub>CC</sub> is below the reset threshold voltage and will remain low until V <sub>CC</sub> returns to a valid level.
7 (MIC706P)	8	RESET	RESET is the compliment of /RESET and is asserted if either V <sub>CC</sub> goes below the reset threshold voltage or by a low signal on the manual reset input (/MR). RESET is suitable for microprocessor systems that use active high reset.

**Absolute Maximum Ratings<sup>(1)</sup>**

Terminal Voltage	
$V_{CC}$ .....	-0.3V to +6.0V
All Other Inputs .....	-0.3V to ( $V_{CC} + 0.3V$ )
Input Current	
$V_{CC}$ , GND .....	25mA
Output Current (All) .....	20mA
Lead Temperature (soldering, 10s) .....	300°C
Storage Temperature ( $T_S$ ) .....	-65°C to +150°C

**Operating Ratings<sup>(2)</sup>**

Operating Temperature Range .....	-40°C to +85°C
Power Dissipation (SOP) .....	400mW
Thermal Resistance	
8-Pin SOIC .....	150°C/W

**Electrical Characteristics<sup>(3)</sup>**

$V_{CC} = 2.70V$  to  $5.5V$  for MIC70\_P/R;  $V_{CC} = 3.00V$  to  $5.5V$  for MIC70\_S;  $V_{CC} = 3.15V$  to  $5.5V$  for MIC70\_T.

$T_A$  = Operating Temperature Range, **bold** values indicate  $-40^\circ\text{C} \leq T_A \leq +85^\circ\text{C}$ , unless noted.

Parameter	Condition	Min.	Typ.	Max.	Units
Operating Voltage Range		1.4		5.5	V
Supply Current				30	$\mu\text{A}$
Reset Voltage Threshold	MIC70_P/R	2.55	2.63	2.70	V
	MIC70_S	2.85	2.93	3.00	
	MIC70_T	3.00	3.08	3.15	
Reset Threshold Hysteresis			20		mV
Reset Pulse Width ( $t_{RS}$ )		140	200	280	ms
/RESET Output Voltage (MIC70_R/S/T)	$I_{SOURCE} = 200\mu\text{A}$	$0.8 \times V_{CC}$			V
	$I_{SINK} = 1.2\text{mA}$			0.3	
	$I_{SINK} = 50\mu\text{A}$ , $V_{CC} = 1.4V$			0.3	
RESET Output Voltage (MIC706P)	$I_{SOURCE} = 200\mu\text{A}$	$0.8 \times V_{CC}$			V
	$I_{SINK} = 1.2\text{mA}$			0.3	
RESET Output Voltage (MIC708R/S/T)	$I_{SOURCE} = 200\mu\text{A}$	$0.8 \times V_{CC}$			V
	$I_{SINK} = 500\mu\text{A}$			0.3	
Watchdog Timeout Period ( $t_{WD}$ )		1.0	1.6	2.25	s
WDI Minimum Input Pulse ( $t_{WP}$ )	$V_{IL} = 0.4V$ , $V_{IH} = 80\%$ of $V_{CC}$	100			ns
	$V_{IL} = 0.4V$ , $V_{IH} = 80\%$ of $V_{CC} > 4.5V$	50			
WDI Threshold Voltage	$V_{IH}$	$0.7 \times V_{CC}$			V
	$V_{IL}$			0.6	
WDI Input Current	WDI = 0V or $V_{CC}$	-1		1	$\mu\text{A}$
WDO Output Voltage	$I_{SOURCE} = 200\mu\text{A}$	$0.8 \times V_{CC}$			V
	$I_{SINK} = 500\mu\text{A}$			0.3	
/MR Pull-Up Current	/MR = 0V	20	250	600	$\mu\text{A}$

**Notes:**

1. Exceeding the absolute maximum ratings may damage the device.
2. The device is not guaranteed to function outside its operating ratings.
3. Specification for packaged product only.

## Electrical Characteristics<sup>(3)</sup> (Continued)

$V_{CC} = 2.70V$  to  $5.5V$  for MIC70\_P/R;  $V_{CC} = 3.00V$  to  $5.5V$  for MIC70\_S;  $V_{CC} = 3.15V$  to  $5.5V$  for MIC70\_T.

$T_A$  = Operating Temperature Range, **bold** values indicate  $-40^{\circ}C \leq T_A \leq +85^{\circ}C$ , unless noted.

Parameter	Condition	Min.	Typ.	Max.	Units
/MR Pulse Width ( $t_{MR}$ )	$V_{CC} > 4.5V$	500			ns
		150			
/MR Input Threshold	$V_{IL}$			0.6	V
	$V_{IH}$	$0.7 \times V_{CC}$			
/MR-to-Reset Output Delay ( $t_{MD}$ )				750	ns
PFI Input Threshold		1.2	1.25	1.3	V
PFI Input Current		-25	0.01	+25	nA
/PFO Output Voltage	$I_{SINK} = 1.2mA$			0.3	V
	$I_{SOURCE} = 200\mu A$	$0.8 \times V_{CC}$			

### Timing Diagram

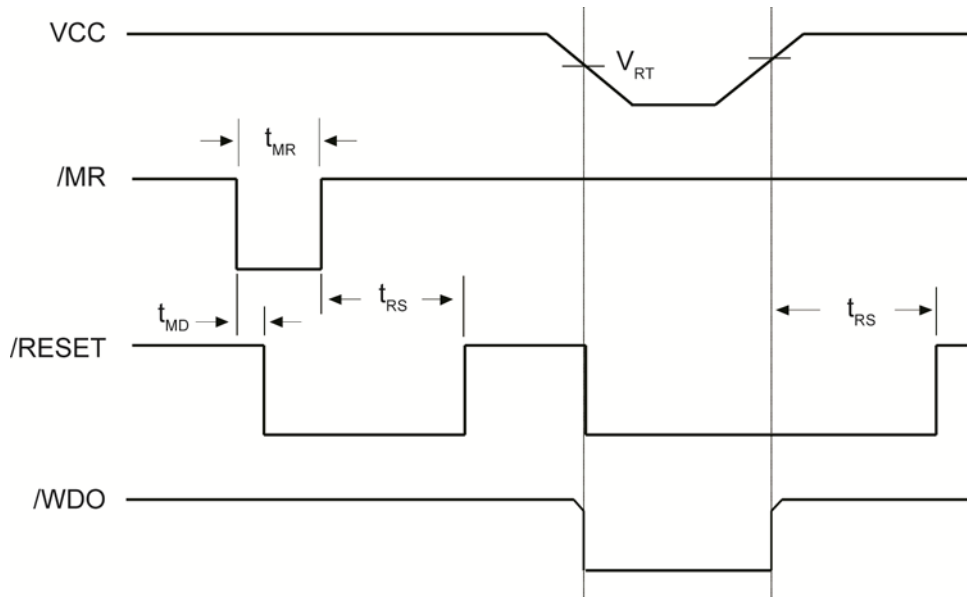
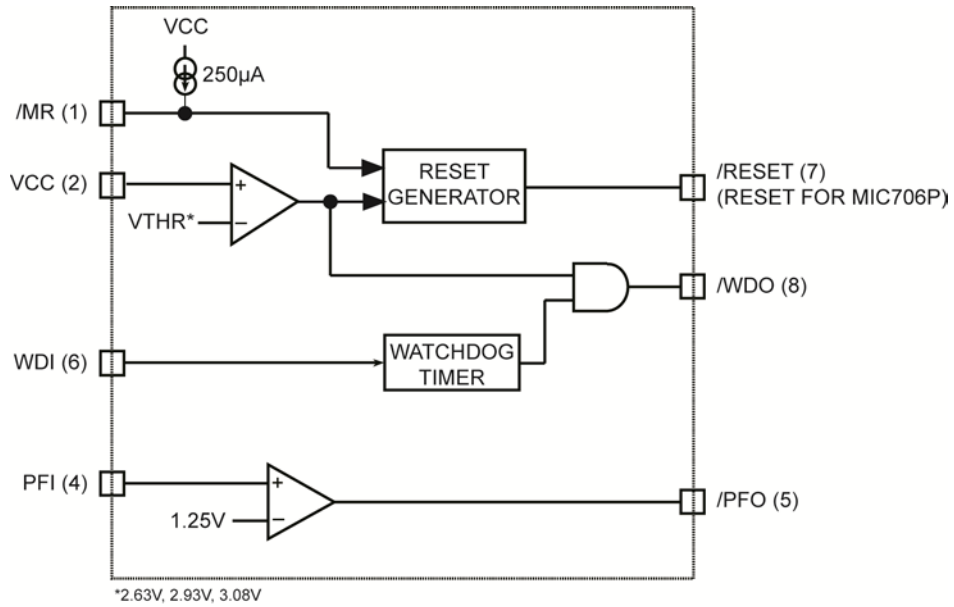
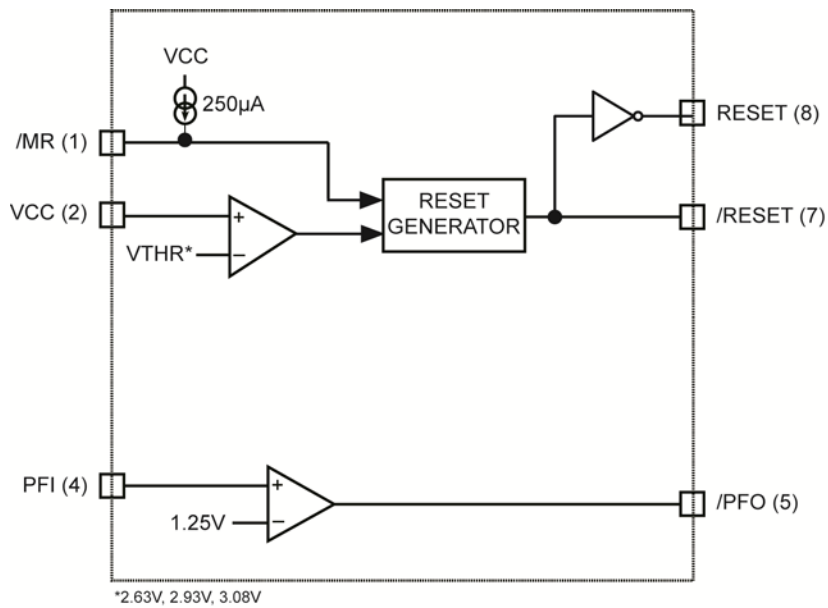

Figure 1. Timing Diagram for Reset

## Block Diagram



**MIC706 Block Diagram**



**MIC708 Block Diagram**

## Application Information

An additional comparator which is independent of the other functions on the MIC706P and MIC708 is provided for early warning of power failure. An external voltage divider can be used to compare unregulated DC to an internal 1.25V reference. The voltage divider ratio on the input of the power-fail comparator (PFI) can be chosen so as to trip the power-fail comparator a few milliseconds before  $V_{CC}$  falls below the maximum reset threshold voltage. The output of the power-fail comparator (/PFO) can be used to interrupt the microprocessor when used in this mode and execute shutdown procedures prior to power loss. Hysteresis can be added to this comparator with external resistors, as is commonly done with any comparator.

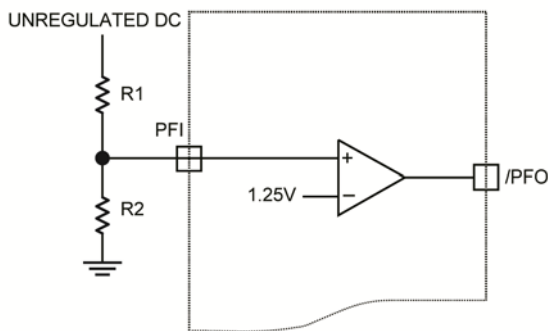

Figure 2. Power-Fail Comparator

## Watchdog Timer

The microprocessor can be monitored by connecting the WDI pin (watchdog input) to a bus line or an I/O line. If a transition doesn't occur on the WDI pin within the watchdog timeout period, then  $\overline{WDO}$  will go low. A minimum pulse of 100ns or any transition low-to-high or high-to-low on the WDI pin will reset the watchdog timer. The output of the watchdog timer ( $\overline{WDO}$ ) will remain high if WDI sees a valid transition within the watchdog period. If  $V_{CC}$  falls below the reset threshold voltage, then  $\overline{WDO}$  goes low immediately regardless of WDI.  $\overline{WDO}$  can be connected to  $\overline{MR}$  to generate a reset pulse upon watchdog timeout.

## Microprocessor Reset

The  $\overline{RESET}$  pin is asserted whenever  $V_{CC}$  falls below the reset threshold voltage or when  $\overline{MR}$  goes low. The reset pin remains asserted for a period of 200ms after  $V_{CC}$  has risen above the reset threshold voltage and  $\overline{MR}$  goes high. The reset function ensures the microprocessor is properly reset and powers up into a known condition after a power failure.  $\overline{RESET}$  will remain valid with  $V_{CC}$  as low as 1.4V.



### Package Information and Recommended Landing Pattern<sup>(4)</sup>

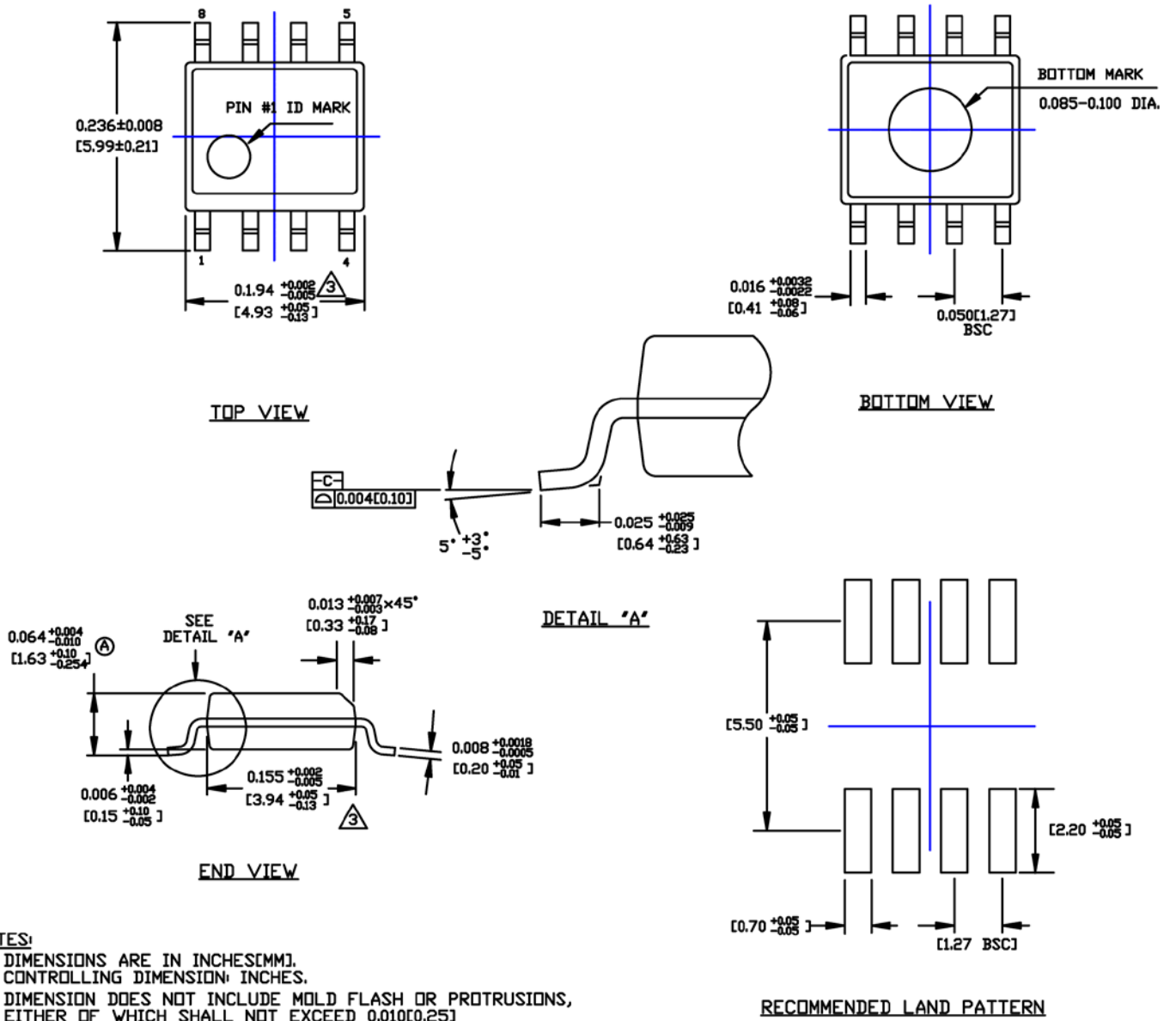

### 8-Pin SOIC (M)

**Note:**

4. Package information is correct as of the publication date. For updates and most current information, go to [www.micrel.com](http://www.micrel.com).

---

**MICREL, INC. 2180 FORTUNE DRIVE SAN JOSE, CA 95131 USA**  
TEL +1 (408) 944-0800 FAX +1 (408) 474-1000 WEB <http://www.micrel.com>

Micrel makes no representations or warranties with respect to the accuracy or completeness of the information furnished in this data sheet. This information is not intended as a warranty and Micrel does not assume responsibility for its use. Micrel reserves the right to change circuitry, specifications and descriptions at any time without notice. No license, whether express, implied, arising by estoppel or otherwise, to any intellectual property rights is granted by this document. Except as provided in Micrel's terms and conditions of sale for such products, Micrel assumes no liability whatsoever, and Micrel disclaims any express or implied warranty relating to the sale and/or use of Micrel products including liability or warranties relating to fitness for a particular purpose, merchantability, or infringement of any patent, copyright or other intellectual property right.

Micrel Products are not designed or authorized for use as components in life support appliances, devices or systems where malfunction of a product can reasonably be expected to result in personal injury. Life support devices or systems are devices or systems that (a) are intended for surgical implant into the body or (b) support or sustain life, and whose failure to perform can be reasonably expected to result in a significant injury to the user. A Purchaser's use or sale of Micrel Products for use in life support appliances, devices or systems is a Purchaser's own risk and Purchaser agrees to fully indemnify Micrel for any damages resulting from such use or sale.

© 2000 Micrel, Incorporated.

## X-ON Electronics

Largest Supplier of Electrical and Electronic Components

*Click to view similar products for [Supervisory Circuits](#) category:*

*Click to view products by [Microchip](#) manufacturer:*

Other Similar products are found below :

[CAT1161LI-25-G](#) [CAT853STBI-T3](#) [CAT1026LI-30-G](#) [CAT1320LI-25-G](#) [TC54VN2402EMB713](#) [MCP1316T-44NE/OT](#) [MCP1316MT-45GE/OT](#) [MCP1316MT-23LI/OT](#) [MAX8997EWW+](#) [MAX6725AKASYD3-LF-T](#) [DS1232L](#) [NCV302HSN45T1G](#) [PT7M6130NLTA3EX](#) [PT7M7811STBEX-2017](#) [S-1000N28-I4T1U](#) [CAT1161LI-28-G](#) [MCP1321T-29AE/OT](#) [MCP1319MT-47QE/OT](#) [S-1000N23-I4T1U](#) [S-1000N19-I4T1U](#) [CAT824UTDI-GT3](#) [TC54VC2502ECB713](#) [PT7M6133NLTA3EX](#) [PT7M6127NLTA3EX](#) [AP0809ES3-r](#) [HG811RM4/TR](#) [MD7030C](#) [MD7033C](#) [MD7019](#) [MD7020](#) [MD7021](#) [MD7023](#) [MD7024](#) [MD7027](#) [MD7030](#) [MD7033](#) [MD7035](#) [MD7036](#) [MD7039](#) [MD7040](#) [MD7044](#) [MD7050](#) [MD7015](#) [MD7022](#) [MD7028](#) [MD7031](#) [MD7042](#) [MD7043](#) [MD7047](#) [MD7060](#)