

General Description

The MIC705, MIC706, MIC707, and MIC708 are inexpensive microprocessor supervisory circuits that monitor power supplies in microprocessor-based systems. The circuit functions include a watchdog timer, microprocessor reset, power-failure warning, and a debounced manual reset input.

The MIC705 and MIC706 offer a watchdog timer function while the MIC707 and MIC708 have an active-high reset output in addition to the active-low reset output.

Supply voltage monitor levels of 4.65V and 4.4V are available. The MIC705 and MIC707 have a nominal reset threshold level of 4.65V while the MIC706 and MIC708 have a 4.4V nominal reset threshold level. When the supply voltage drops below the respective reset threshold level, /RESET is asserted.

Datasheets and support documentation are available on Micrel's web site at: www.micrel.com.

Features

- Debounced manual reset input is TTL/CMOS compatible
- Reset pulse width: 200ms
- Watchdog timer: 1.6s (MIC705/706)
- 4.65V or 4.40V precision voltage monitor
- Early power-fail warning or low-battery detect

Applications

- Automotive systems
- Intelligent systems
- Critical microprocessor power monitoring
- Battery-powered computers
- Computers
- Controllers

Typical Application

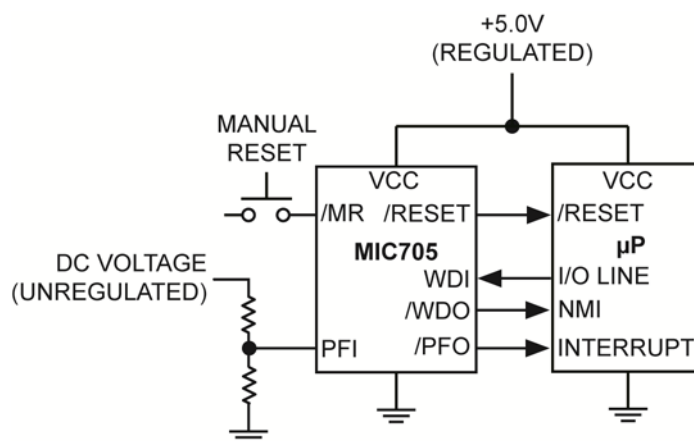

Ordering Information

Part Number	Threshold (V)	/RESET	RESET	WDI	Junction Temperature Range	Package
MIC705MY	4.65	√		√	-40°C to +85°C	8-Pin SOIC
MIC706MY	4.40	√		√	-40°C to +85°C	8-Pin SOIC
MIC707MY	4.65	√	√		-40°C to +85°C	8-Pin SOIC
MIC708MY	4.40	√	√		-40°C to +85°C	8-Pin SOIC

Pin Configuration

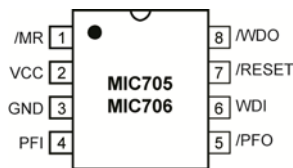

MIC705/706
8-Pin SOIC (M)
(Top View)

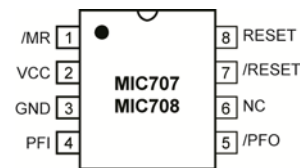

MIC707/708
8-Pin SOIC (M)
(Top View)

Pin Description

Pin Number MIC706	Pin Number MIC708	Pin Name	Pin Name
1	1	/MR	Manual reset input forces /RESET to assert when pulled below 0.8V. An internal pull-up current of 250μA on this input forces it high when left floating. This input can also be driven from TTL or CMOS logic.
2	2	VCC	Primary supply input, +5V.
3	3	GND	IC ground pin, 0V reference.
4	4	PFI	Power-Fail Input: Internally-connected to the power-fail comparator which is referenced to 1.25V. The power-fail output (/PFO) remains high if PFI is above 1.25V. PFI should be connected to GND or VCC if the power-fail comparator is not used.
5	5	/PFO	Power-Fail Output: The power-fail comparator is independent of all other function on this device.
6	N/A	WDI	Watchdog Input. The WDI input monitors microprocessor activity; an internal watchdog timer resets itself with each transition on the watchdog input. If the WDI pin is held high or low for longer than the watchdog timeout period, /WDO is forced to active low. The watchdog function can be disabled by floating the WDI pin.
N/A	6	N/C	Not internally connected.

Pin Description (Continued)

Pin Number MIC706	Pin Number MIC708	Pin Name	Pin Name
7	7	/RESET	/RESET is asserted if either VCC goes below the reset threshold voltage or by low signal on the manual reset input (/MR). /RESET remains asserted for one reset timeout period (200ms) after VCC exceeds the reset threshold voltage or after the manual reset pin transition from low to high. The watchdog timer will not assert /RESET unless /WDO is connected to /MR.
8	N/A	/WDO	Output for the watchdog timer. The watchdog timer resets itself with each transition to the watchdog input. If the WDI pin is held high or low for longer than the watchdog timeout period, /WDO is forced low. /WDO will also be forced low if VCC is below the reset threshold voltage and will remain low until VCC returns to a valid level.
N/A	8	RESET	RESET is the compliment of /RESET and is asserted if either VCC goes below the reset threshold voltage or by a low signal on the manual reset input (/MR). RESET is suitable for microprocessor systems that use active high reset.

Absolute Maximum Ratings⁽¹⁾

Terminal Voltage	
VCC	-0.3V to +6.0V
All Other Inputs.....	-0.3V to (V _{CC} + 0.3V)
Input Current	
VCC, GND	25mA
Output Current (All)	20mA
Lead Temperature (soldering, 10s).....	300°C
Storage Temperature (T _s).....	-65°C to +150°C

Operating Ratings⁽²⁾

Operating Temperature Range	-40°C to +85°C
Power Dissipation (SOP)	400mW
Thermal Resistance	
8-Pin SOIC.....	150°C/W

Electrical Characteristics⁽³⁾

V_{CC} = 4.75V to 5.5V for MIC705/707; V_{CC} = 4.5V to 5.5V for MIC706/708; T_A = Operating Temperature Range, **bold** values indicate -40°C ≤ T_A ≤ +85°C, unless noted.

Parameter	Condition	Min.	Typ.	Max.	Units
Operating Voltage Range		1.4		5.5	V
Supply Current				60	μA
Reset Voltage Threshold	MIC705, MIC707	4.50	4.65	4.75	V
	MIC706, MIC708	4.25	4.4	4.5	
Reset Threshold Hysteresis			40		mV
Reset Pulse Width (t _{RS})		140	200	280	ms
/RESET Output Voltage	I _{SOURCE} = 800μA	V _{CC} - 1.5V			V
	I _{SINK} = 3.2mA			0.4	
RESET Output Voltage	I _{SOURCE} = 800μA	V _{CC} - 1.5V			V
	I _{SINK} = 1.2mA			0.4	
Watchdog Timeout Period (t _{WD})		1.0	1.6	2.25	s
WDI Minimum Input Pulse (t _{WP})	V _{IL} = 0.4V, V _{IH} = 80% of V _{CC}	50			ns
WDI Threshold Voltage	V _{IH} , V _{CC} = 5V	3.5			V
	V _{IL} , V _{CC} = 5V			0.8	
WDI Input Current	WDI = 0V	-150	-50		μA
	WDI = V _{CC}		50	150	
WDO Output Voltage	I _{SOURCE} = 800μA	V _{CC} - 1.5V			V
	I _{SINK} = 1.2mA			0.4	
/MR Pull-Up Current	/MR = 0V	100	250	600	μA

Notes:

1. Exceeding the absolute maximum ratings may damage the device.
2. The device is not guaranteed to function outside its operating ratings.
3. Specification for packaged product only

Electrical Characteristics⁽³⁾ (Continued)

$V_{CC} = 4.75V$ to $5.5V$ for MIC705/707; $V_{CC} = 4.5V$ to $5.5V$ for MIC706/708; T_A = Operating Temperature Range, **bold** values indicate $-40^{\circ}C \leq T_A \leq +85^{\circ}C$, unless noted.

Parameter	Condition	Min.	Typ.	Max.	Units
/MR Pulse Width (t_{MR})		150			ns
/MR Input Threshold	V_{IL}			0.8	V
	V_{IH}	2.0			
/MR-to-Reset Output Delay (t_{MD})				250	ns
PFI Input Threshold	$V_{CC} = 5V$	1.2	1.25	1.3	V
PFI Input Current		-25	0.01	+25	nA
/PFO Output Voltage	$I_{SINK} = 3.2mA$			0.4	V
	$V_{CC} = 5V, I_{SOURCE} = 800\mu A$	$V_{CC} - 1.5V$			

Timing Diagram

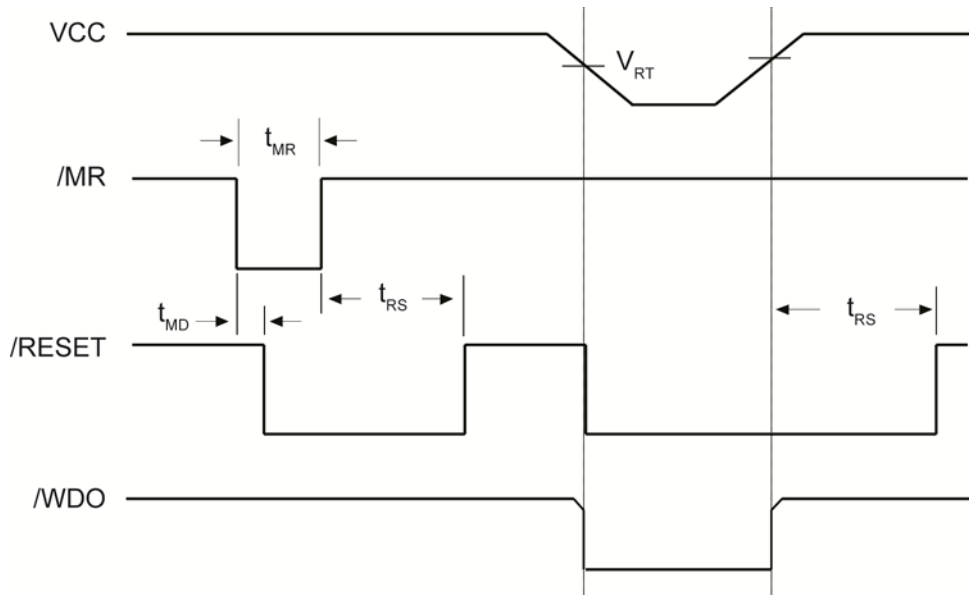
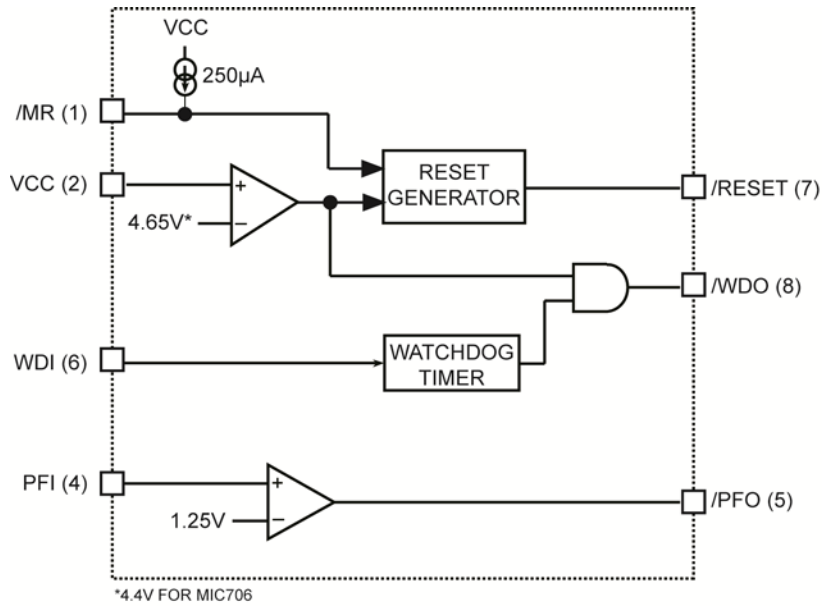
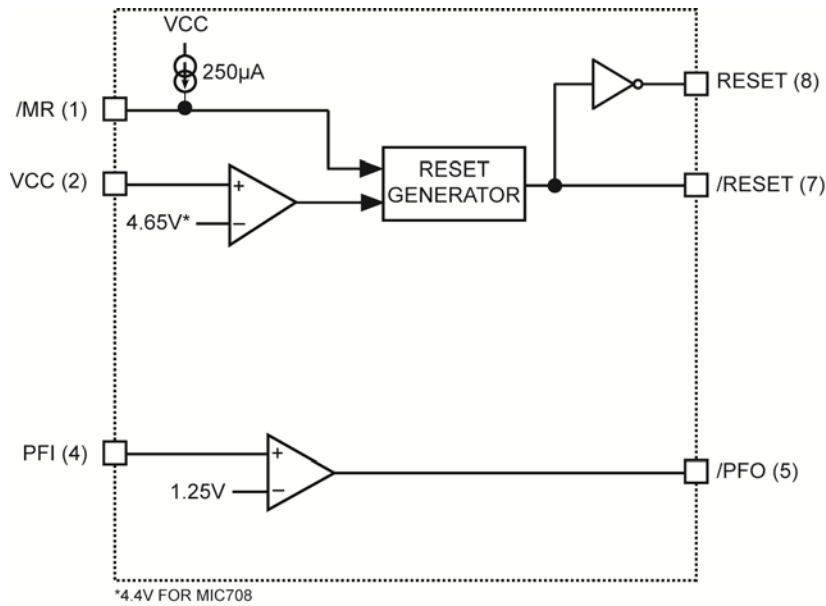

Figure 1. Timing Diagram for Reset

Block Diagrams



MIC705/MIC706 Block Diagram



MIC707/MIC708 Block Diagram

Application Information

Microprocessor Reset

The /RESET pin is asserted whenever V_{CC} falls below the reset threshold voltage or when /MR goes low. The reset pin remains asserted for a period of 200ms after V_{CC} has risen above the reset threshold voltage and /MR goes high. The reset function ensures the microprocessor is properly reset and powers up into a known condition after a power failure. /RESET will remain valid with V_{CC} as low as 1.4V.

Power-Fail Warning

An additional comparator which is independent of the other functions on the MIC706/706/707/708 is provided for early warning of power failure. An external voltage divider can be used to compare unregulated DC to an internal 1.25V reference. The voltage divider ratio on the input of the power-fail comparator (PFI) can be chosen so as to trip the power-fail comparator a few milliseconds before V_{CC} falls below the maximum reset threshold voltage. The output of the power-fail comparator (/PFO) can be used to interrupt the microprocessor when used in this mode and execute shutdown procedures prior to power loss. Hysteresis can be added to this comparator with external resistors, as is commonly done with any comparator.

Watchdog Timer

The microprocessor can be monitored by connecting the WDI pin (watchdog input) to a bus line or an I/O line. If a transition doesn't occur on the WDI pin within the watchdog timeout period, then /WDO will go low. A minimum pulse of 50ns or any transition low-to-high or high-to-low on the WDI pin will reset the watchdog timer. The output of the watchdog timer (/WDO) will remain high if WDI left floating. If V_{CC} falls below the reset threshold voltage, then /WDO goes low immediately regardless of WDI.

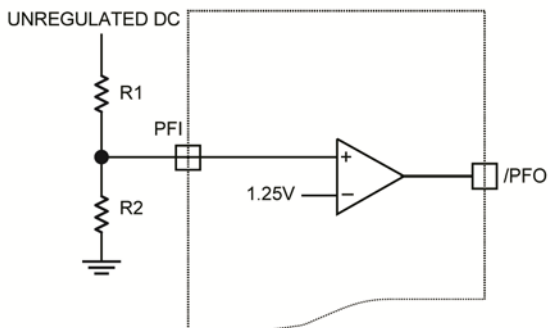
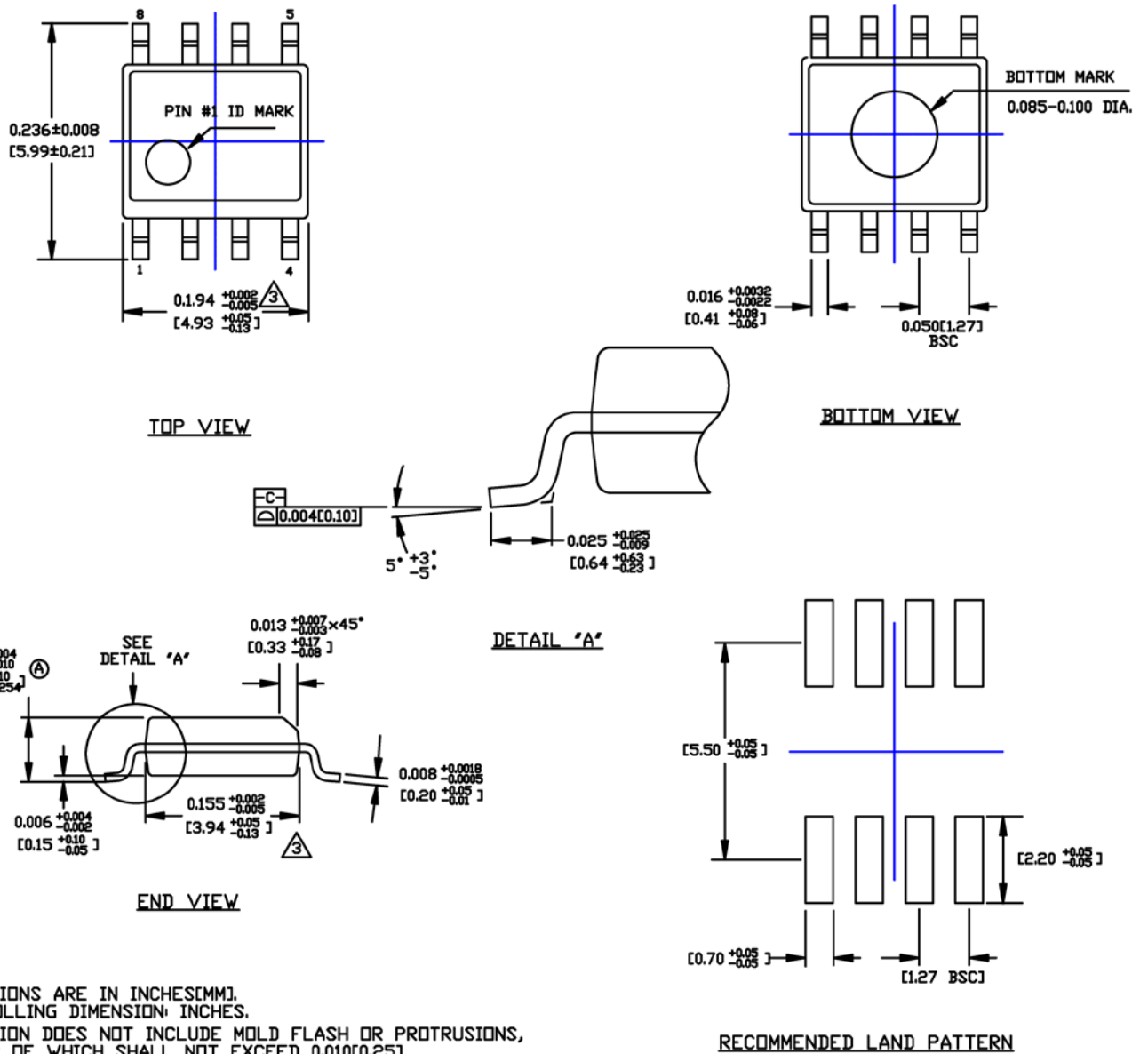

Figure 2. Power-Fail Comparator

Package Information and Recommended Landing Pattern⁽⁴⁾



8-Pin SOIC (M)

Note:

4. Package information is correct as of the publication date. For updates and most current information, go to www.micrel.com.

MICREL, INC. 2180 FORTUNE DRIVE SAN JOSE, CA 95131 USA
TEL +1 (408) 944-0800 FAX +1 (408) 474-1000 WEB <http://www.micrel.com>

Micrel, Inc. is a leading global manufacturer of IC solutions for the worldwide high performance linear and power, LAN, and timing & communications markets. The Company's products include advanced mixed-signal, analog & power semiconductors; high-performance communication, clock management, MEMs-based clock oscillators & crystal-less clock generators, Ethernet switches, and physical layer transceiver ICs. Company customers include leading manufacturers of enterprise, consumer, industrial, mobile, telecommunications, automotive, and computer products. Corporation headquarters and state-of-the-art wafer fabrication facilities are located in San Jose, CA, with regional sales and support offices and advanced technology design centers situated throughout the Americas, Europe, and Asia. Additionally, the Company maintains an extensive network of distributors and reps worldwide.

Micrel makes no representations or warranties with respect to the accuracy or completeness of the information furnished in this datasheet. This information is not intended as a warranty and Micrel does not assume responsibility for its use. Micrel reserves the right to change circuitry, specifications and descriptions at any time without notice. No license, whether express, implied, arising by estoppel or otherwise, to any intellectual property rights is granted by this document. Except as provided in Micrel's terms and conditions of sale for such products, Micrel assumes no liability whatsoever, and Micrel disclaims any express or implied warranty relating to the sale and/or use of Micrel products including liability or warranties relating to fitness for a particular purpose, merchantability, or infringement of any patent, copyright, or other intellectual property right.

Micrel Products are not designed or authorized for use as components in life support appliances, devices or systems where malfunction of a product can reasonably be expected to result in personal injury. Life support devices or systems are devices or systems that (a) are intended for surgical implant into the body or (b) support or sustain life, and whose failure to perform can be reasonably expected to result in a significant injury to the user. A Purchaser's use or sale of Micrel Products for use in life support appliances, devices or systems is a Purchaser's own risk and Purchaser agrees to fully indemnify Micrel for any damages resulting from such use or sale.

© 2000 Micrel, Incorporated.

X-ON Electronics

Largest Supplier of Electrical and Electronic Components

Click to view similar products for [Supervisory Circuits](#) category:

Click to view products by [Microchip](#) manufacturer:

Other Similar products are found below :

[CAT1161LI-25-G](#) [CAT853STBI-T3](#) [CAT1026LI-30-G](#) [CAT1320LI-25-G](#) [TC54VN2402EMB713](#) [MCP1316T-44NE/OT](#) [MCP1316MT-45GE/OT](#) [MCP1316MT-23LI/OT](#) [MAX8997EWW+](#) [MAX6725AKASYD3-LF-T](#) [DS1232L](#) [NCV302HSN45T1G](#) [PT7M6130NLTA3EX](#) [PT7M7811STBEX-2017](#) [S-1000N28-I4T1U](#) [CAT1161LI-28-G](#) [MCP1321T-29AE/OT](#) [MCP1319MT-47QE/OT](#) [S-1000N23-I4T1U](#) [S-1000N19-I4T1U](#) [CAT824UTDI-GT3](#) [TC54VC2502ECB713](#) [PT7M6133NLTA3EX](#) [PT7M6127NLTA3EX](#) [AP0809ES3-r](#) [HG811RM4/TR](#) [MD7030C](#) [MD7033C](#) [MD7019](#) [MD7020](#) [MD7021](#) [MD7023](#) [MD7024](#) [MD7027](#) [MD7030](#) [MD7033](#) [MD7035](#) [MD7036](#) [MD7039](#) [MD7040](#) [MD7044](#) [MD7050](#) [MD7015](#) [MD7022](#) [MD7028](#) [MD7031](#) [MD7042](#) [MD7043](#) [MD7047](#) [MD7060](#)